

THE INFORMATION ON THIS DOCUMENT IS THE PROPERTY OF BHARAT HEAVY ELECTRICALS LTD.
IT MUST NOT BE USED DIRECTLY OR INDIRECTLY IN ANY WAY DETRIMENTAL TO THE INTEREST OF THE COMPANY.

FILE NAME

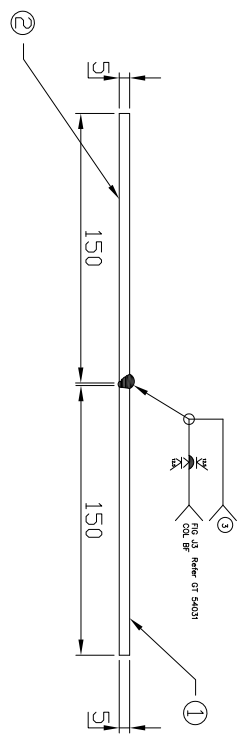
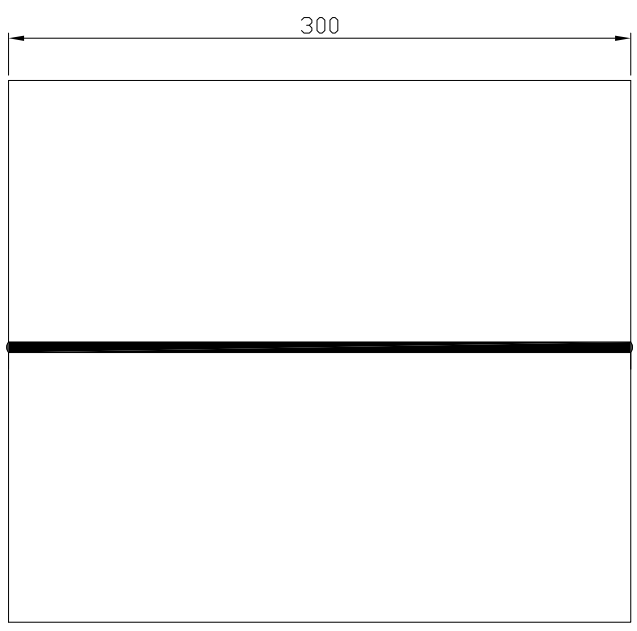

- Notes:
1. Type of Joint: Butt Joint- J Groove
 2. Complete Penetration - Both sides
 3. Accessible - Weld both sides Excavate to sound metal before welding second side
 4. Welding shall be done as per GT54031

Fit-Up Details

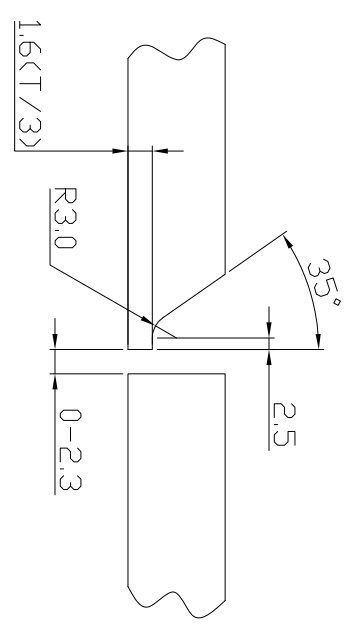

2	Specimen-2	00	Sht 5th x 150 x 300	HY1271862190	01
1	Specimen-1	00	Sht 5th x 150 x 300	HY1271862190	01
REMARKS		TITLE			
REV	DATE	CHECKED	TYPE	GROUP	TITLE
					BHARAT HEAVY ELECTRICALS LTD. HYDERABAD
DRAWN		NAME/SIGNATURE		DATE	
CHECK		SANMUKH		27.10.20	
APPRO		RAMAKRISHNA		27.10.20	
RAVI JATOTH		27.10.20		ESK5060	
DEPT	SGT	OLD DRAWING NO	TITLE	TOOL NO	DRG NO
					D-4253



Sample piece for PQR
Welding of Fr-6 TP Body to Flange
Nimonic to Nimonic welding