



An ISO 9001
Company

Bharat Heavy Electricals Limited

(High Pressure Boiler Plant)

Tiruchirappalli – 620014, TAMIL NADU, INDIA

MATERIALS MANAGEMENT

TITLE ELECTRO FORGED FLOOR GRILLS AS PER ATTACHED DRAWING	Phone: +91 431 257 7457/2577074 Fax : +91 431 252 0719 Email : rsamy@bheltry.co.in
--	---

	Reference Number: Enquiry 1801200173	Enquiry Date: 21.02.2012	Due date for submission of quotation: 26.03.2012
You are requested to quote the Enquiry number date and due date in all your correspondences. This is only a request for quotation and not an order			

BHEL/Trichy is looking for empanelment of new vendors for supply of "Electro Forged Floor Grills as per our attached drawing"

BHEL commercial terms & conditions with Price Bid formats and all annexure can be downloaded from BHEL web site http://www.bhel.com or from the Government tender website http://tenders.gov.in (public sector units) Bharath Heavy Electricals Limited) under enquiry reference "XXXXXXXXX "	
Tenders should reach us before 14:00 hours on the due date Technical bid will be opened at 14:30 hours on the due date Tenders would be opened in presence of the tenderers who have submitted their offers and who may like to be present.	Yours faithfully, For Bharath Heavy Electricals Limited DGM / MM

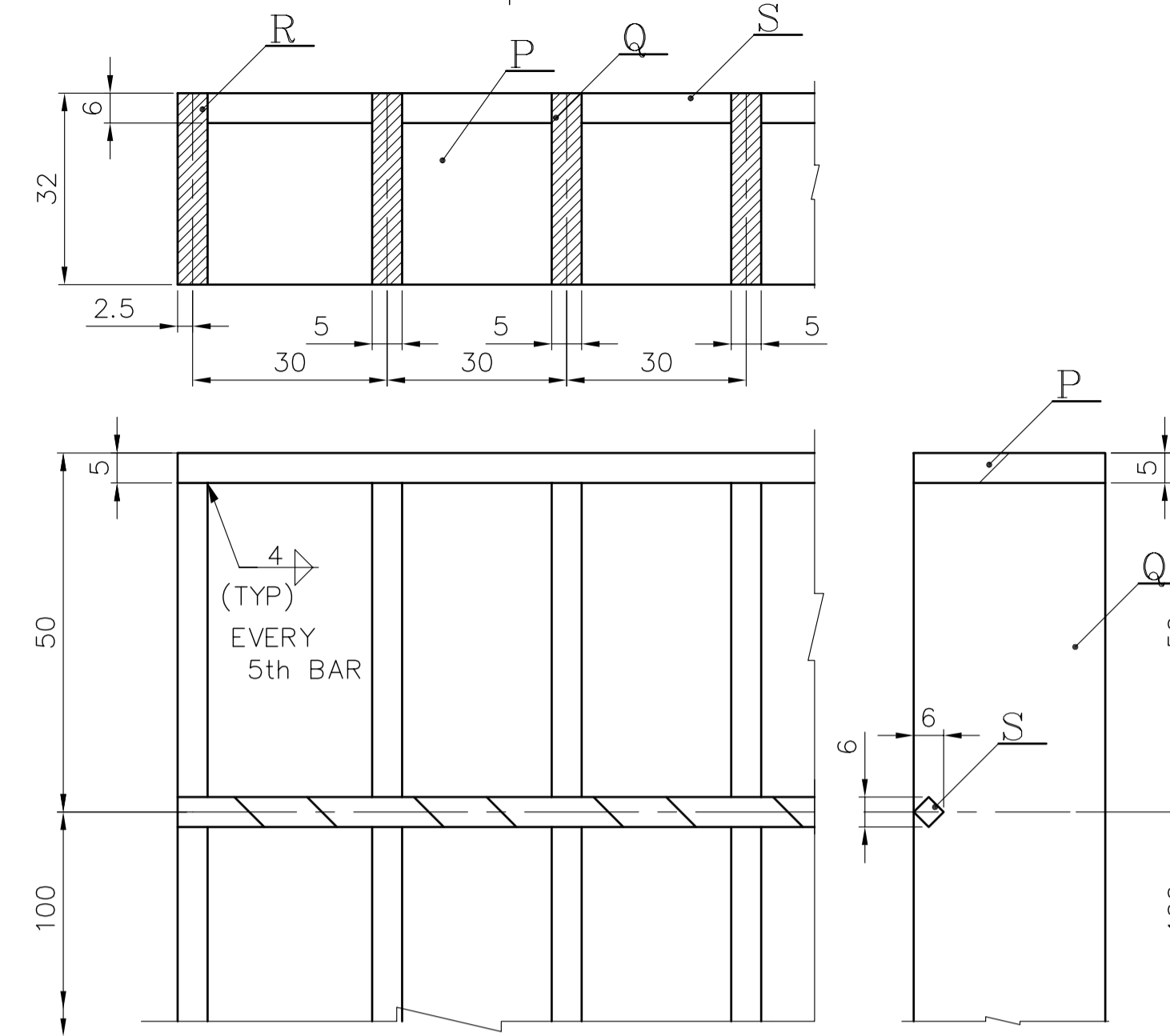
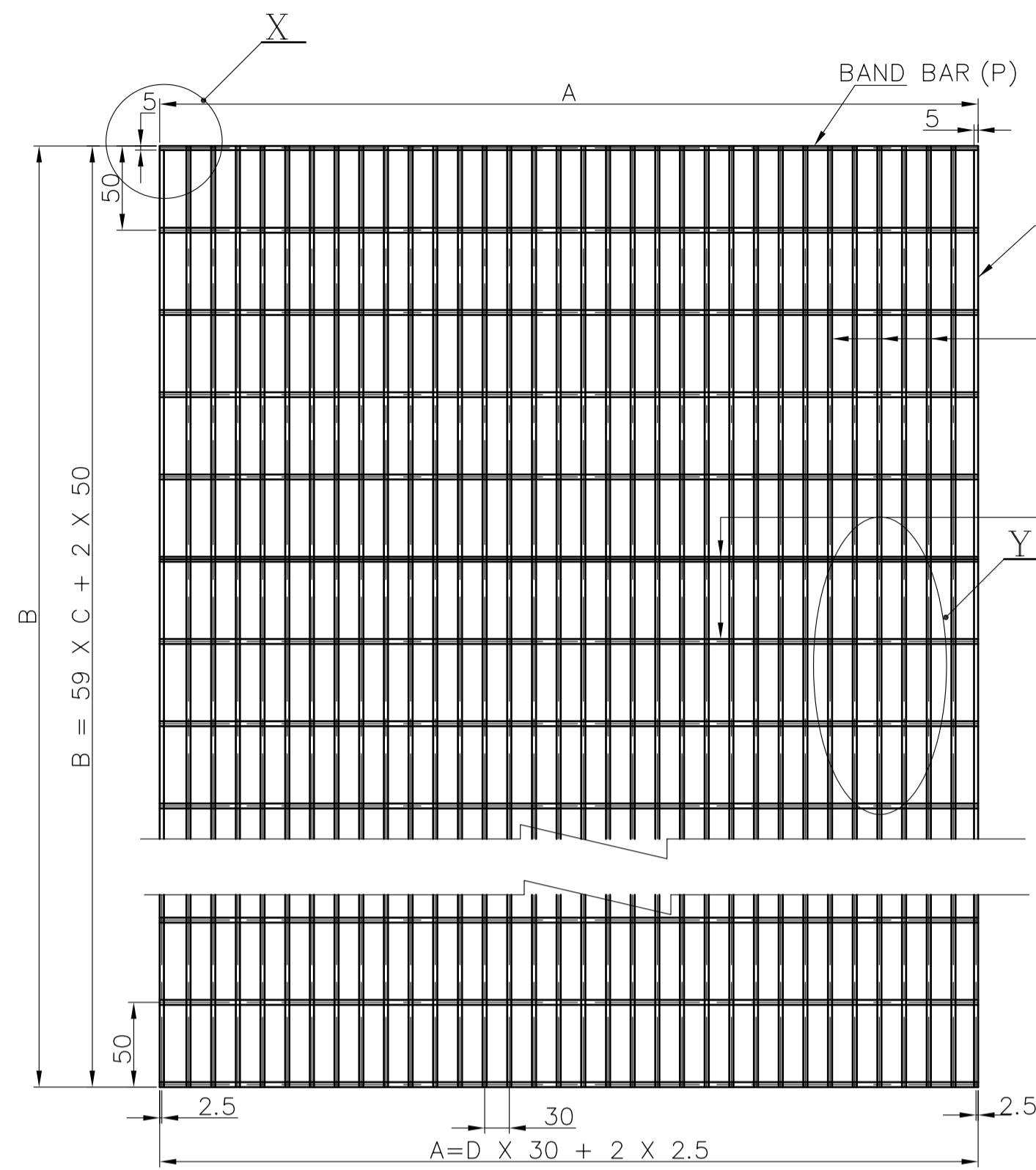

TYPE & SIZE OF WELD	TYPE OF ELECTRODE
4 ∇	E7018

DETAIL-X

S.NO	VARIANT NO	SIZE OF FLOOR GRILL				ITEM NO/NO.OFF								WT. PER FLOOR GRILL BEFORE GALVANISING IN KG	WT. PER FLOOR GRILL AFTER GALVANISING IN KG
		WIDTH A	LENGTH B	C	D	P	Q	R	S						
1	01	305	6000	100	10	01	2	02	9	03	2	04	60	86.099	89.288
2	02	515	6000	100	17	05	2	06	16	07	2	08	60	141.088	146.319
3	03	995	6000	100	33	09	2	10	32	11	2	12	60	266.742	276.639

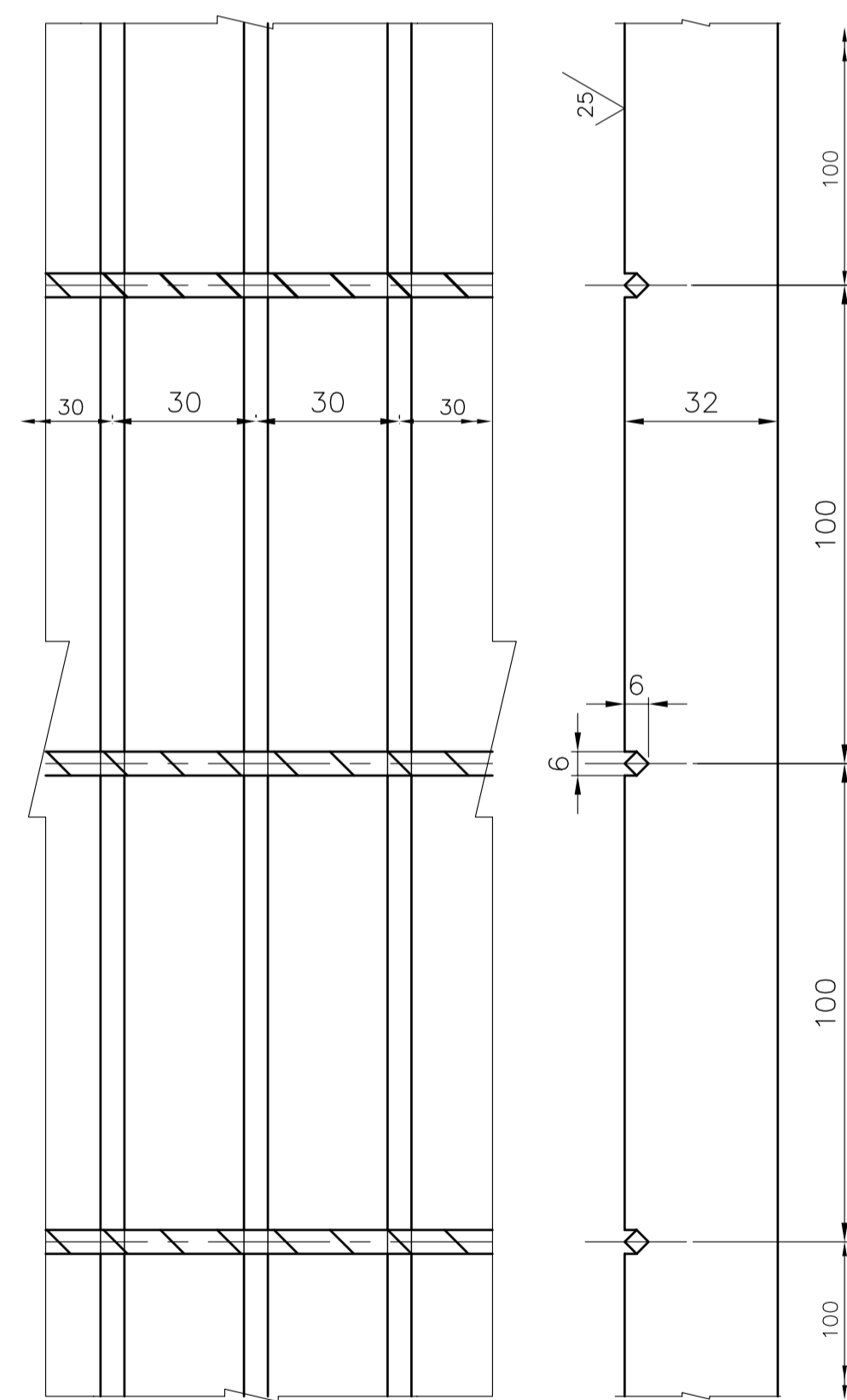

DETAIL-Y

NOTES: -

- FLOOR GRATINGS ARE TO BE GALVANISED BY HOT DIP PROCESS AFTER CLEANING BY PICKLING PROCESS. MINIMUM AVERAGE WEIGHT OF ZINC COATING SHALL BE 610 GRAMS PER SQ. METER.
- STRUCTURAL STEEL CONFORMING TO SPECIFICATION IS 2062 Fe410A ONLY ARE TO BE USED
- GALVANISING TO BE DONE AFTER ALL WORKS ARE COMPLETED.
- ALL SCRATCHED SURFACES AND AREAS DAMAGED BY SITE WELDING SHALL RECEIVE ATLEAST TWO COATS OF COLD GALVANISING USING ZINC RICH PRIMER /PAINTS. THE TOTAL DRY FILM THICKNESS OF SUCH TOUCH UP COLD GALVANISING SHALL NOT BE LESS THAN 150 MICRONS.
- DESIGN LIVE LOAD FOR FLOOR GRILL = 1000 KG/SQ.M IN OPERATING FLOORS AND 500 KG/SQ.M IN NON- OPERATING FLOORS.
- ALL GRATING MEMBERS ARE TO BE ELECTROFORGED EXCEPT BAND BARS.
- WEIGHT OF FLOOR GRILL INDICATED DOES NOT INCLUDE WEIGHT OF WELD, WHICH IS NEGLIGIBLE.
- FLOOR GRILLS ARE SUPPORTED BY INTERMITTENT FLOOR BEAMS SUCH THAT, FLOOR GRILLS TAKE LIVE LOAD AS PER NOTE NO.05 AND THEIR DEFLECTION IS WITHIN $L/325$. FOR OPERATING FLOORS , THE SPAN OF SUPPORTS WILL BE 1.2M MAXIMUM AND FOR NON-OPERATING FLOORS , THE SUPPORT SPAN WILL BE 1.5M MAXIMUM
- FRAME AND LOAD BEARING BAR WELDING : ALL FOUR CORNERS TO BE FULL WELDED TO BAND BARS AND EVERY FIFTH LOAD BEARING BAR TO BE WELDED TO BAND BAR BY MANUAL WELDING FULL DEPTH, AT BOTH ENDS FROM ONE SIDE.
- GRATINGS (32mm THICK) ARE FOR OUT DOOR APPLICATION
- TOLERANCE FOR LENGTH AND WIDTH ± 5 mm

VARIANT NUMBER	ITEM NUMBER	DESCRIPTION	STD	DRAWING NUMBER	ITEM NO	MATERIAL CODE	UNIT	UNIT WEIGHT	QTY	ZONE
03	12	TWISTED SQ. BAR 6mm (DIAGONAL)X 995				IS1786		0.141		
03	11	PLATE 5 32 X 5990				15011029		7.523		
03	10	PLATE 5 32 X 5990				IS2062Fe410A		2		
03	09	PLATE 5 32 X 995				15011029		7.523		
03	08	TWISTED SQ. BAR 6mm (DIAGONAL)X 515				IS2062Fe410A		32		
02	08	PLATE 5 32 X 5990				15011029		1.250		
02	07	PLATE 5 32 X 5990				IS2062Fe410A		2		
02	06	PLATE 5 32 X 5990				15011029		0.073		
02	05	PLATE 5 32 X 515				IS2062Fe410A		60		
01	04	PLATE 5 32 X 5990				15011029		7.523		
01	03	PLATE 5 32 X 5990				IS2062Fe410A		2		
01	02	PLATE 5 32 X 5990				15011029		7.523		
01	01	PLATE 5 32 X 305				IS2062Fe410A		9		
01	01	PLATE 5 32 X 305				15011029		0.383		
01	01	PLATE 5 32 X 305				IS2062Fe410A		2		

REV	DATE	ALTD.	CHD	APPD	REV	DATE	ALTD.	CHD	APPD	REV	DATE	ALTD.	CHD	APPD	REV	DATE	ALTD.	CHD	APPD			
06	03.01.08	kesavon	PENCHAL	RJK	05	10-06-05	KARTHIK	PENCHAL	RJK	04	20-05-05	KARTHIK	PENCHAL	RJK	03	10.09.03	SKR	RRS	02	21.08.03	SKR	RRS
NO.OF BARS INCREASED BASED ON MANUFACTURERS FEED BACK. TOLERANCE FOR LENGTH AND WIDTH ADDED TITLE BLOCK REMOVED DRG. REVISED AS AGREED BY NTPC AS PER CLAUSE 9.0 OF M.O.M OF 4th TCM BETN. BHEL & NTPC dated .10 th & 11.09.'03 DRAWING UPDATED AS PER NTPC TRANSMITTAL FOR DOCUMENTS REF.No. CC:PEV:2240:108:TR:02 Dt.05.08.03 DRAWING TITLE BLOCK UPDATED																						

CAUTION: THE DRAWING IS THE PROPERTY OF BHARAT HEAVY ELECTRICALS LTD., AND IS NOT TO BE REPRODUCED OR USED TO FURNISH ANY INFORMATION FOR MAKING OF DRAWINGS OR APPARATUS EXCEPT WHERE PROVIDED FOR AGREEMENT WITH SAID COMPANY.

BHARAT HEAVY ELECTRICALS LTD				DEPT CODE	DRN	NAME	SIGN	DATE
UNIT:HIGH PRESSURE BOILER PLANT				ST122	CHD	S.K.RAMAN		31/05/03
TIRUCHIRAPPALLI-620 014				APPD	R.RAMASAMY			

TITLE: FLOOR GRILL (6 TWISTED SQUARE - GALVANISED)

BHEL DRG NO. 1-35-811-02525

SCALE: ∇ \odot

REV 07

INTEGRITY PACT

Between

Bharat Heavy Electricals Ltd. (BHEL), a company registered under the Companies Act 1956 and having its registered office at "BHEL House", Siri Fort, New Delhi – 110049 (India) hereinafter referred to as "The Principal", which expression unless repugnant to the context or meaning hereof shall include its successors or assigns of the ONE PART

and

_____, (description of the party along with address), hereinafter referred to as "The Bidder/ Contractor" which expression unless repugnant to the context or meaning hereof shall include its successors or assigns of the OTHER PART

Preamble

The Principal intends to award, under laid-down organizational procedures, contract/s for

_____. The Principal values full compliance with all relevant laws of the land, rules and regulations, and the principles of economic use of resources, and of fairness and transparency in its relations with its Bidder(s)/ Contractor(s).

In order to achieve these goals, the Principal will appoint Independent External Monitor(s), who will monitor the tender process and the execution of the contract for compliance with the principles mentioned above.

Section 1 – Commitments of the Principal

- 1.1 The Principal commits itself to take all measures necessary to prevent corruption and to observe the following principles:-
 - 1.1.1 No employee of the Principal, personally or through family members, will in connection with the tender for, or the execution of a contract, demand, take a promise for or accept, for self or third person, any material or immaterial benefit which the person is not legally entitled to.
 - 1.1.2 The Principal will, during the tender process treat all Bidder(s) with equity and reason. The Principal will in particular, before and during the tender process, provide to all Bidder(s) the same information and will not provide to any Bidder(s) confidential / additional information through which the Bidder(s) could obtain an advantage in relation to the tender process or the contract execution.
 - 1.1.3 The Principal will exclude from the process all known prejudiced persons.
- 1.2 If the Principal obtains information on the conduct of any of its employees which is a penal offence under the Indian Penal Code 1860 and Prevention of Corruption Act 1988 or any other statutory penal enactment, or if there be a substantive suspicion in this regard, the Principal will inform its Vigilance Office and in addition can initiate disciplinary actions.

Section 2 – Commitments of the Bidder(s)/ Contractor(s)

- 2.1 The Bidder(s)/ Contractor(s) commit himself to take all measures necessary to prevent corruption. He commits himself to observe the following principles during his participation in the tender process and during the contract execution.
 - 2.1.1 The Bidder(s)/ Contractor(s) will not, directly or through any other person or firm, offer, promise or give to the Principal or to any of the Principal's employees involved

in the tender process or the execution of the contract or to any third person any material, immaterial or any other benefit which he / she is not legally entitled to, in order to obtain in exchange any advantage of any kind whatsoever during the tender process or during the execution of the contract.

- 2.1.2 The Bidder(s)/ Contractor(s) will not enter with other Bidder(s) into any illegal or undisclosed agreement or understanding, whether formal or informal. This applies in particular to prices, specifications, certifications, subsidiary contracts, submission or non-submission of bids or any other actions to restrict competitiveness or to introduce cartelization in the bidding process.
- 2.1.3 The Bidder(s)/ Contractor(s) will not commit any penal offence under the relevant IPC/ PC Act; further the Bidder(s)/ Contractor(s) will not use improperly, for purposes of competition or personal gain, or pass on to others, any information or document provided by the Principal as part of the business relationship, regarding plans, technical proposals and business details, including information contained or transmitted electronically.
- 2.1.4 The Bidder(s)/ Contractor(s) will, when presenting his bid, disclose any and all payments he has made, and is committed to or intends to make to agents, brokers or any other intermediaries in connection with the award of the contract.
- 2.2 The Bidder(s)/ Contractor(s) will not instigate third persons to commit offences outlined above or be an accessory to such offences.

Section 3 – Disqualification from tender process and exclusion from future contracts

If the Bidder(s)/ Contractor(s), before award or during execution has committed a transgression through a violation of Section 2 above, or acts in any other manner such as to put his reliability or credibility in question, the Principal is entitled to disqualify the Bidder(s)/ Contractor(s) from the tender process or take action as per the separate "Guidelines on Banning of Business dealings with Suppliers/ Contractors". framed by the Principal.

Section 4 – Compensation for Damages

- 4.1 If the Principal has disqualified the Bidder from the tender process prior to the award according to Section 3, the Principal is entitled to demand and recover the damages equivalent Earnest Money Deposit/Bid Security.
- 4.2 If the Principal has terminated the contract according to Section 3, or if the Principal is entitled to terminate the contract according to section 3, the Principal shall be entitled to demand and recover from the Contractor liquidated damages equivalent to 5% of the contract value or the amount equivalent to Security Deposit/Performance Bank Guarantee, whichever is higher.

Section 5 – Previous Transgression

- 5.1 The Bidder declares that no previous transgressions occurred in the last 3 years with any other company in any country conforming to the anti-corruption approach or with any other Public Sector Enterprise in India that could justify his exclusion from the tender process.
- 5.2 If the Bidder makes incorrect statement on this subject, he can be disqualified from the tender process or the contract, if already awarded, can be terminated for such reason.

Section 6 – Equal treatment of all Bidders/ Contractors/ Sub-contractors

- 6.1 The Bidder(s)/ Contractor(s) undertake(s) to obtain from all subcontractors a commitment consistent with this Integrity Pact and report Compliance to the Principal. This commitment shall be taken only from those sub-contractors whose contract value is more than 20 % of Bidder's/ Contractor's contract value with the Principal. The Bidder(s)/ Contractor(s) shall continue to remain responsible for any default by his Sub-contractor(s).
- 6.2 The Principal will enter into agreements with identical conditions as this one with all Bidders and Contractors.
- 6.3 The Principal will disqualify from the tender process all bidders who do not sign this pact or violate its provisions.

Section 7 – Criminal Charges against violating Bidders/ Contractors /Sub-contractors

If the Principal obtains knowledge of conduct of a Bidder, Contractor or Subcontractor, or of an employee or a representative or an associate of a Bidder, Contractor or Subcontractor which constitutes corruption, or if the Principal has substantive suspicion in this regard, the Principal will inform the Vigilance Office.

Section 8 –Independent External Monitor(s)

- 8.1 The Principal appoints competent and credible Independent External Monitor for this Pact. The task of the Monitor is to review independently and objectively, whether and to what extent the parties comply with the obligations under this agreement.

- 8.2 The Monitor is not subject to instructions by the representatives of the parties and performs his functions neutrally and independently. He reports to the CMD, BHEL.
- 8.3 The Bidder(s)/ Contractor(s) accepts that the Monitor has the right to access without restriction to all contract documentation of the Principal including that provided by the Bidder(s)/ Contractor(s). The Bidder(s)/ Contractor(s) will grant the monitor, upon his request and demonstration of a valid interest, unrestricted and unconditional access to his contract documentation. The same is applicable to Sub-contractor(s). The Monitor is under contractual obligation to treat the information and documents of the Bidder(s)/ Contractor(s) / Sub-contractor(s) with confidentiality.
- 8.4 The Principal will provide to the Monitor sufficient information about all meetings among the parties related to the contract provided such meetings could have an impact on the contractual relations between the Principal and the Contractor. The parties offer to the Monitor the option to participate in such meetings.
- 8.5 As soon as the Monitor notices, or believes to notice, a violation of this agreement, he will so inform the Management of the Principal and request the Management to discontinue or take corrective action, or heal the situation, or to take other relevant action. The Monitor can in this regard submit non-binding recommendations. Beyond this, the Monitor has no right to demand from the parties that they act in a specific manner, refrain from action or tolerate action.
- 8.6 The Monitor will submit a written report to the CMD, BHEL within 8 to 10 weeks from the date of reference or intimation to him by the Principal and, should the occasion arise, submit proposals for correcting problematic situations.
- 8.7 The CMD, BHEL shall decide the compensation to be paid to the Monitor and its terms and conditions.
- 8.8 If the Monitor has reported to the CMD, BHEL, a substantiated suspicion of an offence under relevant IPC / PC Act, and the CMD, BHEL has not, within reasonable time, taken visible action to proceed against such offence or reported it to the Vigilance Office, the

Monitor may also transmit this information directly to the Central Vigilance Commissioner, Government of India.

8.9 The number of Independent External Monitor(s) shall be decided by the CMD, BHEL.

8.10 The word 'Monitor' would include both singular and plural.

Section 9 – Pact Duration

9.1 This Pact begins and shall be binding on and from the submission of bid(s) by bidder(s). It expires for the Contractor 12 months after the last payment under the respective contract and for all other Bidders 6 months after the contract has been awarded.

9.2 If any claim is made / lodged during this time, the same shall be binding and continue to be valid despite the lapse of this pact as specified as above, unless it is discharged/ determined by the CMD, BHEL.

Section 10 – Other Provisions

10.1 This agreement is subject to Indian Laws and jurisdiction shall be registered office of the Principal, i.e. New Delhi.

10.2 Changes and supplements as well as termination notices need to be made in writing. Side agreements have not been made.

10.3 If the Contractor is a partnership or a consortium, this agreement must be signed by all partners or consortium members.

10.4 Should one or several provisions of this agreement turn out to be invalid, the remainder of this agreement remains valid. In this case, the parties will strive to come to an agreement to their original intentions.

10.5 Only those bidders/ contractors who have entered into this agreement with the Principal would be competent to participate in the bidding. In other words, entering into this agreement would be a preliminary qualification.

For & On behalf of the Principal

For & On behalf of the Bidder/ Contractor

(Office Seal)

(Office Seal)

Place-----

Date-----

Witness: _____

Witness: _____

(Name & Address) _____

(Name & Address) _____

Special terms & conditions to Electro Forged floor grills For IMPORT vendors
Enquiry no: 1801200173/13 dt 21.02.2012

Sl.no	Conditions	Vendor conformation
1	Offer shall be submitted in TWO PART bid i.e Technical offer with commercial terms & conditions in one envelope & price bid in another envelope, duly sealed.	
2	Price may be finalized thro " <u>On line Reverse Auction Process</u> " using internet. Please confirm your acceptance.	
3	Offer should be valid for a minimum period of 60 days, from the date of Price Bid Opening/ Reverse Auction.	
4	Tender will be finalized on the basis of "Project wise total cost to BHEL".	
5	"Rate per number" to be quoted on "FOB Basis" and the Sea Freight amount to be indicated Separately. If required the same will be operated.	
6	The monthly production capacity " <u>sparable to BHEL/Trichy</u> " against this tender to be clearly indicated in the offer.	_____ MT/Month
7	If the vendor is not conforming to our technical / drawing requirements in total, their offer will not be considered for further evaluation in this tender.	
8	Delay in dispatches shall attract a penalty of Liquidated damages (LD) @ 0.5% per week, subject to maximum of 15%. Any change in this clause is NOT ACCEPTABLE and offer with different clauses is liable for rejection	
9	Lowest Prices received against BHEL tender need not be the technically acceptable one and in that case BHEL reserve the right not to consider the same	
10	Guarantees shall be given for twelve months from the date of receipt of the material at site or eighteen months from the date of dispatch.	
11	BHEL reserves the right to increase or decrease the tendered quantity.	
12	Our normal payment terms 100 % in 45 days from date of dispatch of material. However we can accept usance LC with 45 days interest free credit only in case of import vendors, suitable price loading will be done for the LC payments in tender evaluation.	
13	All the material supplied will be as per BHEL's drawing no 1-35-811-02525/07	
14	BHEL may at its discretion split the ordering quantities at L1 rates if required. Ordering shall be on more than one vendor i.e upto L1, L2 & L3 and sharing will be based on the project requirement, vendor capacity and the eligibility criteria in the tender.	
15	Sharing shall be as 60%, 25%, 15% of tender quantity on each package on L1, L2 & L3 vendor respectively.	

(Vendor Sign & Seal)

Special terms & conditions to Electro Forged floor grills For Indigenous vendors
Enquiry no: 1801200173/13 dt 21.02.2012

Sl.no	Conditions	Vendor conformation
1	Offer shall be submitted in TWO PART bid i.e Technical offer with commercial terms & conditions in one envelope & price bid in another envelope, duly sealed.	
2	Price may be finalized thro " On line Reverse Auction Process " using internet. Please confirm your acceptance.	
3	Offer should be valid for a minimum period of 60 days, from the date of Price Bid Opening/Reverse Auction.	
4	Tender will be finalized on the basis of "Total cost basis to BHEL".	
5	"Rate per number" to be quoted on "Ex-works" basis.	
6	Applicable Duties, taxes. etc shall be indicated separately.	
7	In case of " Mega Power Projects International Competitive Bidding " payment of ED is Exempted, hence vendors need not pay ED. Necessary project documents will be furnished by BHEL to vendor to avail ED Exemption	
8	Vendor may quote their rates for a) " With PAC " and b) " Without PAC " options.	
9	The monthly production capacity " <u>sparable to BHEL/Trichy</u> " against this tender to be clearly indicated in the offer.	_____MT/Month
10	If the vendor is not conforming to our technical / drawing requirements in total, their offer will not be considered for further evaluation in this tender.	
11	Delay in dispatches shall attract a penalty of Liquidated damages (LD) @ 0.5% per week, subject to maximum of 15%. Any change in this clause is NOT ACCEPTABLE and offer with different clause liable for rejection.	
12	Lowest Prices received against BHEL tender need not be the technically acceptable one and in that case BHEL reserve the right not to consider the same	
13.	Guarantees shall be given for Twelve months from the date of receipt of the material at site or Eighteen months from the date of dispatch.	
14	BHEL reserves the right to increase or decrease the tendered quantity.	
15	Payment term: 100% payment will be made in 45 days from the date of receipt of material at site.LC Payment term is not acceptable.	
16	All the material supplied will be as per BHEL's drawing no 1-35-811-02525/07	
17	BHEL may at its discretion split the ordering quantities at L1 rates if required. Ordering shall be on more than one vendor i.e upto L1, L2 & L3 and sharing will be based on the project requirement, vendor capacity and the eligibility criteria in the tender.	
18	Sharing shall be as 60%, 25%, 15% of tender quantity on each package on L1, L2 & L3 vendor respectively.	

(Vendor Sign & Seal)

**Commercial Terms& conditions for Enquiry no: 1801200173/13 dt 21.02.2012
(Indigenous Vendors)**

SL NO	CONDITIONS	BHEL TERMS	Accepted/Not Accepted
1	Delivery Terms	Ex Works (Name of place)	
2	Delivery period	30.06.2012	
3	ED	Vendor to quote	
4	CST/VAT	Vendor to quote	
5	Freight	BHEL Scope	
6	Insurance	by BHEL	
7	LD	Delay in dispatches shall attract a penalty of Liquidated damages (LD) @ 0.5% per week, subject to maximum of 15%	
8	Risk Purchase	Applicable	
9	PBG	Not Applicable	
10	Payment terms	100% payment will be made in 45 days from the date of dispatch of material.	
11	Validity	60 days from the date of RA/Price bid opening	
12	Firm Price	Firm Price	
13	PVC	Not Applicable	
14	Packing Forwarding	Vendor Scope	
15	Guarantee/Warranty	12 months from the date of receipt of the material at site or Eighteen months from the date of dispatch.	

(Vendor Sign & Seal)

**Commercial Terms& conditions for Enquiry no: 1801200173/13 dt 21.02.2012
(Import Vendors)**

SL NO	CONDITIONS	BHEL TERMS	Accepted/Not Accepted
1	Delivery Terms	CIF Chennai	
2	Delivery period	30.06.2012	
3	ED	Not Applicable	---
4	CST/VAT	Not Applicable	---
5	Freight from Chennai to Project Site	BHEL Scope	
6	Insurance	by BHEL (for Chennai to Site movement)	
7	LD	Delay in dispatches shall attract a penalty of Liquidated damages (LD) @ 0.5% per week, subject to maximum of 15%	
8	Risk Purchase	Applicable	
9	PBG	Not Applicable	
10	Payment terms	100 % thro bank in 45 days from date of receipt of material. However we can accept usance LC with 45 days interest free credit only in case of import vendors, suitable loading will be done for the other payments.	
11	Validity	60 days from date of RA/Price bid opening	
12	Firm Price	Firm Price	
13	PVC	Not Applicable	
14	Packing Forwarding	Vendor Scope	
15	Guarantee/Warranty	12 months from the date of receipt of the material at site or Eighteen months from the date of dispatch.	

(Vendor Sign & Seal)

BHEL TRICHY-14 MM / FB/SD

REF: FB: PUR: 33EFG/OT

DATED: 21.02.2012

SPECIAL CONDITIONS

1. This tender is for the supply of Electro Forged Floor Grills of sizes 32x995x6000, 32x515x6000 and 32x305x6000 as per BHEL drawing no 1-35-811-02525/07 attached with this tender. The floor grills has to be galvanized.
2. The vendor shall have adequate experience in manufacturing and supply of Electro forged Floor Grills.
3. Vendor shall indicate in their offer clearly the monthly tonnage that can be manufactured in their factory against the requirement and also their total manufacturing capacity in MT / Month. Vendors also have to send an Integrity pact as per format given by BHEL.
4. The tender is in two parts. One part consisting of commercial and technical conditions and other with price details. Techno-Commercial bid and price bid are to be submitted in separate sealed covers. In addition to technical and commercial conditions, vendors who are not registered vendor of BHEL, Trichy have to submit the filled in "Supplier Registration Forms" (available in www.bhel.com) along with the technical bid. Based on this and other conditions, as well as capacity and capability, vendors will be short-listed. Both these covers are to be put in a single cover duly super scribing the Enquiry Number. The technical and commercial bid will be opened on the due date and based on the acceptance of techno-commercial bid and vendor evaluation, the price bid/RA of the qualified vendors will be opened on a suitable date with due intimation.

Following will be the criteria for vendors to qualify:

- a. Vendor should have been approved by BHEL Trichy for this items under Permanent category (OR)
 - b. Vendor should submit the following documents for considering them as an approved vendor:
 - i. Duly filled-in Supplier Registration Forms.
 - ii. Availability of minimum manufacturing, handling, testing and measuring facilities as detailed in the Supplier Registration Form.
 - iii. BHEL will have the right for spot assessment of the facilities for assessment.
 - iv. Qualifying to our techno commercial requirements of the Enquiry.
5. BHEL reserves the right to increase or decrease the tendered quantity and split the tendered quantity among more than one tenderer and place orders accordingly in any proportion based on commitment, requirement and supplier's capability in terms of delivery and quality as assessed by BHEL.
 6. BHEL reserves the right to negotiate the L1 rate.

7. BHEL reserves the right to re-float the tender opened, if L1 price is not the lowest acceptable price to BHEL inter-alia other reasons.
8. BHEL reserves the right to order on more than one vendor at the lowest acceptable price to BHEL.
9. Vendors have to confirm to the Commercial Terms and Special Terms & Conditions attached.
10. BHEL standard LD condition is 0.50 % per week to a maximum of 15 % for the undelivered portion of materials.
11. 100 % payment will be made in 45 days from the date of delivery of material.

(Sachin Saini)
ET/MM/SD – Fossil Boilers

Specification

Supply of Electro Forged Floor Grills made of steel of sizes 32x995x6000, 32x515x6000 and 32x305x6000 as per BHEL drawing no 1-35-811-02525/07 attached with this tender.

Specification of structural steel must be as per BHEL drawing.

The material shall be galvanized by Hot Dip Process with average weight of Zinc coating be 610 gms per sqm.

Total Requirement

Sl. No	Description	Qty	Remarks
1	Electro Forged Floor Grills 32x995x6000	8885	
2	Electro Forged Floor Grills 32x515x6000	3175	
3	Electro Forged Floor Grills 32x305x6000	3900	

The project wise quantity will be intimated before opening of the price bid/Reverse Auction.

(Sachin Saini)
ET/MM/SD – Fossil Boilers