



An ISO 9001
Company

Bharat Heavy Electricals Limited

(High Pressure Boiler Plant)

Tiruchirappalli – 620014, TAMIL NADU, INDIA

MATERIALS MANAGEMENT

TITLE BOILER ROOF SHEETS AS PER ATTACHED DRAWING	Phone: +91 431 257 7457/2577074 Fax : +91 431 252 0719 Email : rksamy@bheltry.co.in
---	---

	Reference Number: Enquiry 1801201023	Enquiry Date: 13.08.2012	Due date for submission of quotation: 17.09.2012
You are requested to quote the Enquiry number date and due date in all your correspondences. This is only a request for quotation and not an order			

BHEL/Trichy is looking for empanelment of new vendors for supply of "Boiler Roof Sheets as per our attached drawing"

BHEL commercial terms & conditions with Price Bid formats and all annexure can be downloaded from BHEL web site http://www.bhel.com or from the Government tender website http://tenders.gov.in (public sector units) Bharath Heavy Electricals Limited) under enquiry reference "XXXXXXXXXX "	
Tenders should reach us before 14:00 hours on the due date Technical bid will be opened at 14:30 hours on the due date Tenders would be opened in presence of the tenderers who have submitted their offers and who may like to be present.	Yours faithfully, For Bharath Heavy Electricals Limited DGM / MM

Annexure I - Lot Wise Sizes, Qty & Specs

Annexure I - Lot Wise Sizes, Qty & Specs				
Lot 1	Gorgi DBPL			SPECIFICATION: Boiler Roof Covering materials shall be 30 mm overall depth. Base Material – Steel shall confirm to ASTM-A-446 Grade E having yield strength of 550Mpa. Nominal thickness – 0.65 MM(Total coated thickness), Galvanizing: Hot dipper metallic coating of aluminum zinc alloy 150 gm/sqm as per AS1397 Top Side Paint: Top side coating shall be 20 microns minimum of Silicon modified Polyester (SMP) painting over primer coat on exposed side. Bottom Side paint: A neutral back coat over a primer coat over galvalume steel on backside of sheets. Note: The colour of sheet shall be Blue (RAL 5012)
S. No	Material	Size	Qty	
1	Profile Sheet	.65x1060x1600	6440	
2	Barge Board	.65x400x2440	120	
3	Ridge Piece	.65x400x2440	50	
	Plain Sheet	.65x1000x3000	20	
		Total	6630	
Lot 2	Lalitpur			
S. No	Material	Size	Qty	SPECIFICATION : Continuously prepainted galvanized steel sheets to specification IS:14246 As per following requirements Base Material – Mild steel as per IS-513. Nominal thickness – 0.63 MM, Galvanizing: The base metal shall be galvanized with minimum grade of zinc coating 275 grams / sq.m as per IS:277 Top Side Paint: Top side coating shall be 20 microns minimum of Silicon Modified Polyester (SMP) painting. Bottom Side paint: Bottom side coating shall be 7 microns minimum of Silicon Modified Polyester (SMP) painting. Durability of paint coating: As per Class-2 of IS:14246 Colour: Blue (RAL 5012)
1	Profile Sheet	.63x1060x1600	4500	
2	Barge Board	.63x400x2440	525	
4	Plain Sheet	.63x1000x3000	30	
		Total	5055	
Lot 3	SCCL			
S. No	Material	Size	Qty	
1	Profile Sheet	.63x1060x1600	5900	
2	Barge Board	.63x400x2440	100	
4	Ridge Piece	.63x400x2440	60	
	Plain Sheet	.63x1000x3000	20	
		Total	6080	

G Total

17765

CAUTION: THE INFO ON THIS DOCUMENT IS THE PROPERTY OF BHEL. IT MUST NOT BE USED DIRECTLY OR INDIRECTLY IN ANY WAY DETRIMENTAL TO THE INTEREST OF BHEL.

FOR TOLERANCES OF UNTOLERANCED DIMENSIONS DURING MANUFACTURE REFER PLANT STD. NO TP 023 0299

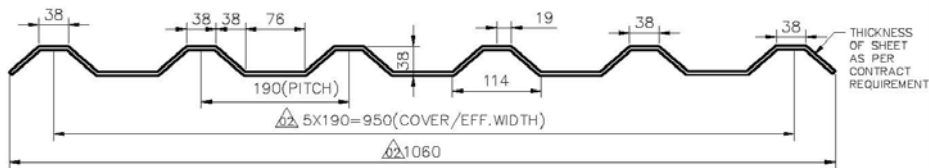
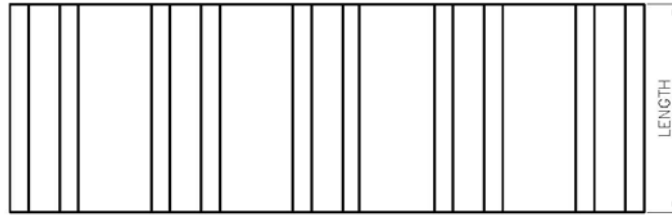

TYPE-I

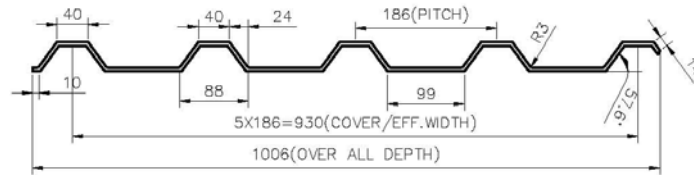

TYPE-II

REV	DATE	ALTERED : S.SEMILA
02	29.07.06	CHD & APPD :R.J.K

DRAWING PITCH ADDED.

REV	DATE	ALTERED :
01		CHD & APPD :

TYPE-I & TYPE-II DETAILS SEPARTELY GIVEN

VARIANT NUMBER	DESCRIPTION	STD	MATERIAL CODE		UNIT	UNIT WEIGHT
			MATERIAL SPECN	A/C/P		QUANTITY



Bharat Heavy Electricals Ltd
UNIT: HIGH PRESSURE BOILER PLANT
TIRUCHIRAPALLI - 620014

DRN	P.RAMACHANDRAN	SIGNATURE Sd.....	DATE 20.01.2000
CHD	M.B.K.RAJA	Sd.....	20.01.2000
APPD	R.RAMASAMY	Sd.....	20.01.2000

DEPT	ALL DIMENSIONS ARE IN MM	PROJECTION	SCALE	WEIGHT (Kg)	REF TO ASSY / OLD DWG
CODE					

TITLE	DRAWING NO :	REV
METAPOLY TRAPEZOIDAL PROFILE SHEET	4-35-611-00333	02

CAUTION: THE MEMO ON THIS DOCUMENT IS THE PROPERTY OF BHEL. IT IS NOT TO BE USED DIRECTLY OR INDIRECTLY IN ANY WAY DEPREMIATING TO THE INTERESTS OF BHEL.

REV 01	DATE	ALTERED : CHD & APPD :	REV 02	DATE	ALT: JAFFAR CHD: R.R.S.	ALL DIMENSIONS ARE IN MM FOR TOLERANCES OF UNTOLERANCED DIMENSIONS DURING MANUFACTURE REFER RELEVANT QCP / OP
OVER ALL WIDTH & EFFECTIVE WIDTH CORRECTED.			0.8 mm SHEET ADDED OVER ALL WIDTH & EFFECTIVE WIDTH MARKED			

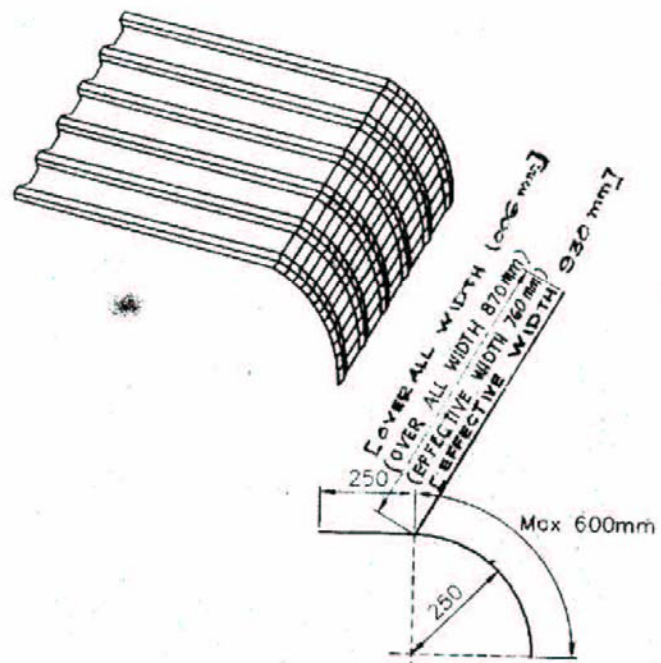

01	METAPOLY VENTILATOR CURVE 1.0 MM THICK				
VARIANT NUMBER	DESCRIPTION	STD	MATERIAL CODE	A/C	UNIT
					UNIT WEIGHT
			MATERIAL SPECN		QUANTITY

		Bharat Heavy Electricals Ltd UNIT: HIGH PRESSURE BOILER PLANT TIRUCHIRAPPALLI - 620014		DRN B.S./A.R.	NAME <i>A. Sajid</i>	SIGNATURE <i>A. Sajid</i>	DATE 11.01.97	NO. OF VAR
DEPT ST		SCALE N.T.S.	WEIGHT (Kg)	APPD R.M.A.	REF TO ASBY / OLD DWG	ITEM NO	No OF ITEMS	
CODE 122	TITLE METAPOLY TRAPEZOIDAL PROFILE VENTILATOR CURVE		CARD CODE U 01	DRAWING NO : 4-35-611-00321			REV 02	

CAUTION: THE VIEW ON THIS DOCUMENT IS THE PROPERTY OF IHEL. IT IS TO BE KEPT IN CONFIDENCE AND NOT TO BE REPRODUCED OR TRANSMITTED IN ANY WAY DETRIMENTAL TO THE INTEREST OF IHEL.

ALL DIMENSIONS ARE IN MM
 FOR TOLERANCES OF UNTOLERANCED
 DIMENSIONS DURING MANUFACTURE
 REFER RELEVANT QCP / QP

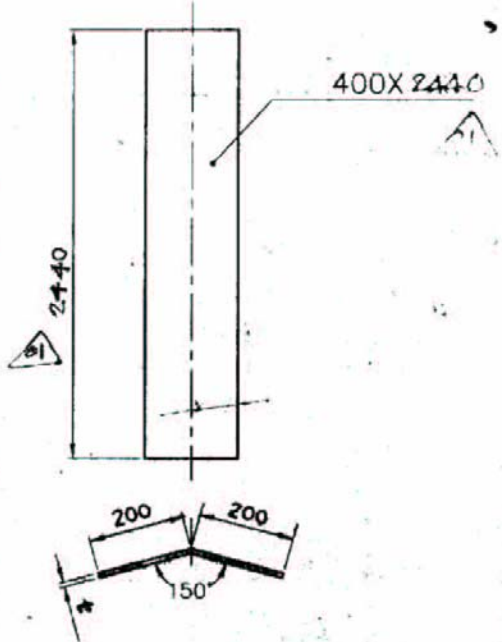

RIDGE PIECE

NOTES:
 1. META POLY SHEET
 (POLY STEEL) COLD
 ROLLED WITH ZINC
 COATING IN A CONTI-
 NUOUS HOT DIP
 GALVANISING LINE &
 SUBSEQUENTLY
 GIVEN 5 LAYERS OF
 ORGANIC COATING.



t = THICKNESS
 0.8mm, 1.0mm

REV	DATE	4/7/2011	01	METAPOLY SHEET RIDGE PIECE t - TK.				
			ITEM NUMBER	DESCRIPTION	STD	MATERIAL CODE	UNIT	UNIT WEIGHT
						MATERIAL SPECN		QUANTITY

 Bharat Heavy Electricals Ltd UNIT: HIGH PRESSURE BOILER PLANT TIRUCHIRAPALLI - 620014		NAME DRN: A.RAJENDRAN QND: R.R.SAMY APPR: R.M.A.	SIGNATURE 	DATE 08/07/11	NO. OF SHEETS 01
DEPT ST		SCALE 1:10, N.T.S.	WEIGHT (Kg)	REF TO ASSY / OLD Dwg	ISSUED TO
CODE 122					
TITLE DETAILS OF RIDGE PIECE			CARD CODE U-01	DRAWING NO : 4-35-611-00317	REV 01



CAUTION: THE INFO ON THIS DOCUMENT IS THE PROPERTY OF BHEL. IT MUST NOT BE USED DIRECTLY OR INDIRECTLY IN ANY WAY DETRIMENTAL TO THE INTEREST OF BHEL.

BARGE BOARD

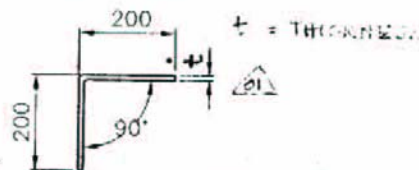
ALL DIMENSIONS ARE IN MM
FOR TOLERANCES OF UNTOLERANCED
DIMENSIONS DURING MANUFACTURE
REFER RELEVANT QCP / QP

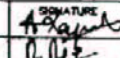
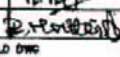

REV	DATE	ALTERED BY	DESCRIPTION	STD	MATERIAL CODE	A/C	UNIT	UNIT WEIGHT
01	21-10-2007	CHD/R.APPD	02 METAPOLY BARGE BOARD 0.8 MM TK.					
02			01 METAPOLY BARGE BOARD 1.0 MM TK.					

		Bharat Heavy Electricals Ltd UNIT: HIGH PRESSURE BOILER PLANT TRUCHIRAPALLI - 620014		DSN CHD APPD	NAME B.S/A.R R.R.SAMY R.M.A.	SIGNATURE   	DATE 	NO. OF VAR
DEPT	ST	SCALE	WEIGHT (Kg)	REF TO ASSY / OLD DWG		ITEM NO	NO OF ITEMS	
CODE	122	1:10						
TITLE DETAILS OF BARGE BOARD CORNER PIECE				CARD CODE U-01	DRAWING NO : 4-35-611-00323	REV 01	16/10/07	

THE SIGNAL ON THIS DOCUMENT IS THE PROPERTY OF BHEL. IT MUST NOT BE USED DIRECTLY OR INDIRECTLY IN ANY WAY DETRIMENTAL TO THE INTEREST OF BHEL.

REV	DATE	ALTERED	JAFFAR
01	3.10.97	CHD & APPD	

0.8 mm THICK SHEET
ADDENDUM

ALL DIMENSIONS ARE IN MM
FOR TOLERANCES OF UNTOLERANCED
DIMENSIONS DURING MANUFACTURE
REFER RELEVANT QCP / OP

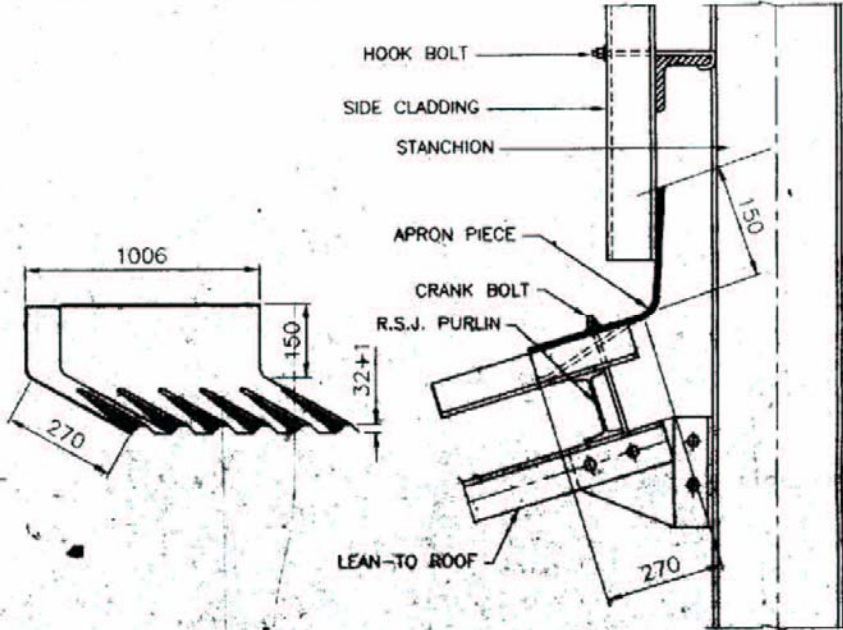

APRON PIECE 110

VARIANT NUMBER	METAPOLY SHEET 1.0mm THICK [0.8mm]	MATERIAL CODE	A/C	UNIT	UNIT WEIGHT
	DESCRIPTION				QUANTITY
		MATERIAL SPECN			

		Bharat Heavy Electricals Ltd UNIT: HIGH PRESSURE BOILER PLANT TIRUCHIRAPALLI - 620014		DESIGNED BY: S.S./R.R. CHECKED BY: R.A.S. APPROVED BY: R.M.A.	SIGNATURE: [Signature] DATE: 11.01.97	NO. OF VARS: 16/197
DEPT: ST	SCALE: N.T.S.	WEIGHT (Kg):	REV TO: NONE / SEE QCP	ITEM NO:	NO. OF ITEMS:	
DOCK: 122						
TITLE: METAPOLY TRAPEZOIDAL PROFILE APRON PIECE			DRAWING NO: 4-35-611-00320	REV: 01		

**BHEL TRICHY
MM / FB/SD/13**

REF: FB: BOI: 38MPS/OT

DATED: 13.08.2012

SPECIAL CONDITIONS

1. This tender is for the supply of Pre-painted Roof Sheets as per specs, size and quantities mentioned in Annexure I attached to this enquiry.
2. The vendor shall have adequate experience in manufacturing and supply of Pre Painted Galvanized Roof Sheets
3. Vendor shall indicate in their offer clearly the monthly tonnage that can be manufactured in their factory against the requirement and also their total manufacturing capacity in MT / Month. Vendors also have to send an Integrity pact as per format given by BHEL.
4. The tender is in two parts. One part consisting of commercial and technical conditions and other with price details. Techno-Commercial bid and price bid are to be submitted in separate sealed covers. In addition to technical and commercial conditions, vendors who are not registered vendor of BHEL, Trichy have to submit the filled in "Supplier Registration Forms" (available in www.bhel.com) along with the technical bid. Based on this and other conditions, as well as capacity and capability, vendors will be short-listed. Both these covers are to be put in a single cover duly super scribing the Enquiry Number. The technical and commercial bid will be opened on the due date and based on the acceptance of techno-commercial bid and vendor evaluation, the price bid/RA of the qualified vendors will be opened on a suitable date with due intimation.

Following will be the criteria for vendors to qualify:

- a. Vendor should have been approved by BHEL Trichy for this items under Permanent category (OR)
 - b. Vendor should submit the following documents for considering them as an approved vendor:
 - i. Duly filled-in Supplier Registration Forms.
 - ii. Availability of minimum manufacturing, handling, testing and measuring facilities as detailed in the Supplier Registration Form.
 - iii. BHEL will have the right for spot assessment of the facilities for assessment.
 - iv. Qualifying to our techno commercial requirements of the Enquiry.
5. BHEL reserves the right to increase or decrease the tendered quantity and split the tendered quantity among more than one tenderer and place orders accordingly in any proportion based on commitment, requirement and supplier's capability in terms of delivery and quality as assessed by BHEL.
 6. BHEL reserves the right to negotiate the L1 rate.

7. BHEL reserves the right to re-float the tender opened, if L1 price is not the lowest acceptable price to BHEL inter-alia other reasons.
8. BHEL reserves the right to order on more than one vendor at the lowest acceptable price to BHEL.
9. Vendors have to confirm to the Commercial Terms and Special Terms & Conditions attached.
10. BHEL standard LD condition is 0.50 % per week to a maximum of 15 % for the undelivered portion of materials.
11. 100 % payment will be made in 45 days from the date of receipt of materials with 10 % bank guarantee or 90% payments will be made after dispatch and 10% after receipt of material.

NOTE:

For material specifications, sizes and quantities please refer Annexure I to this enquiry. There are two types of specifications and requirement is for both as mentioned in the annexure. The orders will be finalized on project wise Lot basis and the quantities for the various projects will be intimated before reverse auction/ Price bid opening.

(Sachin Saini)
Engineer/BOI
sachinsaini@bheltry.co.in
0431-257 7426

Special terms & conditions to Boiler Roof Sheets For IMPORT vendors
Enquiry no: 1801201023 DT: 13.08.2012

Sl.no	Conditions	Vendor conformation
1	Offer shall be submitted in TWO PART bid i.e Technical offer with commercial terms & conditions in one envelope & price bid in another envelope, duly sealed.	
2	Price may be finalized thro " <u>On line Reverse Auction Process</u> " using internet. Please confirm your acceptance.	
3	Offer should be valid for a minimum period of 60 days, from the date of Price Bid Opening/ Reverse Auction.	
4	Tender will be finalized on the basis of "Project wise total cost to BHEL".	
5	"Rate per number" to be quoted on "FOB Basis" and the Sea Freight amount to be indicated Separately. If required the same will be operated.	
6	The monthly production capacity " <u>sparable to BHEL/Trichy</u> " against this tender to be clearly indicated in the offer.	_____ MT/Month
7	If the vendor is not conforming to our technical / drawing requirements in total, their offer will not be considered for further evaluation in this tender.	
8	Delay in dispatches shall attract a penalty of Liquidated damages (LD) @ 0.5% per week, subject to maximum of 15%. Any change in this clause is NOT ACCEPTABLE and offer with different clauses is liable for rejection	
9	Lowest Prices received against BHEL tender need not be the technically acceptable one and in that case BHEL reserve the right not to consider the same	
10	Guarantees shall be given for twelve months from the date of receipt of the material at site or eighteen months from the date of dispatch.	
11	BHEL reserves the right to increase or decrease the tendered quantity.	
12	Our normal payment terms 100 % in 45 days from date of dispatch of material. However we can accept usance LC with 45 days interest free credit only in case of import vendors, suitable price loading will be done for the LC payments in tender evaluation.	
13	All the material supplied will be as per BHEL's drawings and specifications as published with this enquiry.	

(Vendor Sign & Seal)

Special terms & conditions to Boiler Roof Sheets For Indigenous vendors

Enquiry no: 1801201023 DT: 13.08.2012

Sl.no	Conditions	Vendor conformation
1	Offer shall be submitted in TWO PART bid i.e Technical offer with commercial terms & conditions in one envelope & price bid in another envelope, duly sealed.	
2	Price may be finalized thro " On line Reverse Auction Process " using internet. Please confirm your acceptance.	
3	Offer should be valid for a minimum period of 60 days, from the date of Price Bid Opening/Reverse Auction.	
4	Tender will be finalized on the basis of "Total cost basis to BHEL".	
5	"Rate per number" to be quoted on "Ex-works" basis.	
6	Applicable Duties, taxes. etc shall be indicated separately.	
7	In case of " Mega Power Projects International Competitive Bidding " payment of ED is Exempted, hence vendors need not pay ED. Necessary project documents will be furnished by BHEL to vendor to avail ED Exemption	
8	Vendor may quote their rates for a) " With PAC " and b) " Without PAC " options.	
9	The monthly production capacity " <u>sparable to BHEL/Trichy</u> " against this tender to be clearly indicated in the offer.	_____MT/Month
10	If the vendor is not conforming to our technical / drawing requirements in total, their offer will not be considered for further evaluation in this tender.	
11	Delay in dispatches shall attract a penalty of Liquidated damages (LD) @ 0.5% per week, subject to maximum of 15%. Any change in this clause is NOT ACCEPTABLE and offer with different clause liable for rejection.	
12	Lowest Prices received against BHEL tender need not be the technically acceptable one and in that case BHEL reserve the right not to consider the same	
13.	Guarantees shall be given for Twelve months from the date of receipt of the material at site or Eighteen months from the date of dispatch.	
14	BHEL reserves the right to increase or decrease the tendered quantity.	
15	Payment term: 100% payment will be made in 45 days from the date of receipt of material at site.LC Payment term is not acceptable.	
16	All the material supplied will be as per BHEL's drawings and specifications as published with this enquiry.	

(Vendor Sign & Seal)

**Commercial Terms& conditions for Enquiry no: 1801201023 DT: 13.08.2012
(Indigenous Vendors)**

SL NO	CONDITIONS	BHEL TERMS	Accepted/Not Accepted
1	Delivery Terms	Ex Works (Name of place)	
2	Delivery period	24.11.2012	
3	ED	Vendor to quote	
4	CST/VAT	Vendor to quote	
5	Freight	BHEL Scope	
6	Insurance	by BHEL	
7	LD	Delay in dispatches shall attract a penalty of Liquidated damages (LD) @ 0.5% per week, subject to maximum of 15%	
8	Risk Purchase	Applicable	
9	Bank Guarantee	10% of order value	
10	Payment terms	100% payment will be made in 45 days from the date of dispatch of material with 10% bank Guarantee or 90% payments will be made after dispatches and 10% on receipt of material.	
11	Validity	60 days from the date of RA/Price bid opening	
12	Firm Price	Firm Price	
13	PVC	Not Applicable	
14	Packing Forwarding	Vendor Scope	
15	Guarantee/Warranty	12 months from the date of receipt of the material at site or Eighteen months from the date of dispatch.	

(Vendor Sign & Seal)

**Commercial Terms& conditions for Enquiry no: 1801201023 DT: 13.08.2012
(Import Vendors)**

SL NO	CONDITIONS	BHEL TERMS	Accepted/Not Accepted
1	Delivery Terms	CIF Chennai	
2	Delivery period	24.11.2012	
3	Freight from Chennai to Project Site	BHEL Scope	
4	Insurance	by BHEL (for Chennai to Site movement)	
5	LD	Delay in dispatches shall attract a penalty of Liquidated damages (LD) @ 0.5% per week, subject to maximum of 15%	
6	Risk Purchase	Applicable	
7	PBG	Not Required	
8	Payment terms	100 % thro bank in 45 days from date of receipt of material. However we can accept usance LC with 45 days interest free credit only in case of import vendors, suitable loading will be done for the other payments.	
9	Validity	60 days from date of RA/Price bid opening	
10	Firm Price	Firm Price	
11	PVC	Not Applicable	
12	Packing Forwarding	Vendor Scope	
13	Guarantee/Warranty	12 months from the date of receipt of the material at site or Eighteen months from the date of dispatch.	

(Vendor Sign & Seal)