

BHARAT HEAVY ELECTRICALS LIMITED

Page
1/8

(A Government of India Undertaking)
HIGH PRESSURE BOILER PLANT
PURCHASE DEPARTMENT - FOSSIL BOILERS
THIRUCHIRAPALLI - 620014
TAMILNADU (INDIA)

PHONE : 0431-2574737
GRAMS : BHARATELEC
FAX NO: 0431-2520719
E-mail: pramila@bhel.in
Web:

Enquiry No	Enquiry Date	Due Date for Quotation
1902200001 - 53	28.01.2022	10.02.2022

Please quote Enquiry No, Date and due date in all correspondences. This is only a request for quotation and not an order.
Bid should be submitted in two parts. 1. Techno-commercial bid (Part-I) and 2. Price bid (Part-II) in a separate sealed cover and both covers must be placed in a third cover and sealed. Our Enquiry No., Enq. date & Enq. Due date must be written on all three covers.

Item	Description	Unit	Quantity	Delivery Quantity	Schedule Date
10	200054040000 K.S.CHEM.T.R.W BOXES 600X500X400MM CTR WOOD BOX Type T-654 and as per drawing number 3-SH-B-004/C	NO	180.000	180.00	31.03.23
20	200054050000 K.S.CHEM.T.R.W BOXES 900X600X600MM CTR WOOD BOX Type T-966 and as per drawing number 2-SH-CRT-00002/B	NO	490.000	490.00	31.03.23
30	200054060000 K.S.CHEM.T.R.W BOXES1200X900X600MM CTR WOOD BOX Type T-1296 and as per drawing number 2-SH-CRT-00002/B	NO	550.000	550.00	31.03.23
40	200054070000 K.S.CHEM.T.R.W BOXES1300X900X900MM K.S.CHEM.T.R.W BOXES 1300X900X900MM as per the drawing number 2-SH-CRT-00002/B	NO	480.000	480.00	31.03.23
50	200054080000 K.S.CHEM.T.R.W BOXES1500X700X700MM CTR WOOD BOX Type T-1577 and as per drawing number 2-SH-CRT-00002/B	NO	330.000	330.00	31.03.23
60	200054090000 K.S.CHEM.T.R.W BOXES1050X1050X500MM CTR WOOD BOX Size 1050x1050x500 and as per drawing number 3-SH-B-004/C	NO	160.000	160.00	31.03.23
70	200054100000 K.S.CHEM.T.R.W BOXES1600X900X1000MM K.S.CHEM.T.R.W BOXES1600X900X1000mm as per drawing number 3-SH-B-005	NO	315.000	315.00	31.03.23
80	200054110000 K.S.CHEM.T.R.W BOXES800X200X200MM	NO	120.000	120.00	31.03.23

The offers should reach us 30 minutes before the time of opening of tenders. The offers will be opened at 14.30 hrs on the due date of tender in the presence of tenderers who have submitted their offer and who may like to be present for the tender opening. Late and delayed offers are liable to be rejected.

Yours faithfully,
For **BHARAT HEAVY ELECTRICALS LIMITED**

R. KILLIVALAVAN
Senior Engineer
PURCHASE / PSS / MW
BHEL, TRICHY
MANAGER / PURCHASE
(FOSSIL BOILERS)
Yours faithfully,
For **BHARAT HEAVY ELECTRICALS LIMITED**

BHARAT HEAVY ELECTRICALS LIMITED

Page
2/8



429-002/A

(A Government of India Undertaking)
HIGH PRESSURE BOILER PLANT
PURCHASE DEPARTMENT - FOSSIL BOILERS
THIRUCHIRAPALLI - 620014
TAMILNADU (INDIA)

PHONE :0431-2574737
GRAMS : BHARATELEC
FAX NO: 0431-2520719
E-mail: pramila@bhel.in
Web:

1902200001 / 28.01.2022

23505

90	200054120000	NO	60.000	60.00	31.03.23
	KILN SEASONED CHEMICALLY TREATED RUBBER WOODEN BOXES AS PER PR:CHEM:20/03 TO TYPE:SPA; AND BHEL DRG:40-SPM-SH-00001/01 AND TO SIZE:800x200x200 mm				
	K.S.CHEM.T.R.W BOXES 1500X200X200MM				
100	200054130000	NO	60.000	60.00	31.03.23
	KILN SEASONED CHEMICALLY TREATED RUBBER WOODEN BOXES AS PER PR:CHEM:20/03 TO TYPE:SPB; AND BHEL DRG:40-SPM-SH-00001/01 AND TO SIZE:1500x200x200 mm				
	K.S.CHEM.T.R.W BOXES 2000X200X200MM				
110	200054140000	NO	120.000	120.00	31.03.23
	KILN SEASONED CHEMICALLY TREATED RUBBER WOODEN BOXES AS PER PR:CHEM:20/03 TO TYPE:SPC;AND BHEL DRG:40-SPM-SH-00001/01 AND TO SIZE:2000x200x200 mm				
	K.S.CHEM.T.R.W BOXES 1100X200X200MM				
120	200054150000	NO	130.000	130.00	31.03.23
	K.S.CHEM.T.R.W BOXES 1100X200X200MM K.S.CHEM.T.R.W BOXES 1100X200X200MM and as per drawing number 3-SH-B-004 / B, Rev 01				
130	200054160000	NO	120.000	120.00	31.03.23
	K.S.CHEM.T.R.W BOXES 1100X400X400MM K.S.CHEM.T.R.W BOXES 1100X400X400mm (TYPE-SPI) as per BHEL Drawing Number 40-SPM-SH-00002/01				
140	200054170000	NO	65.000	65.00	31.03.23
	K.S.CHEM.T.R.W BOXES 1500X500X400MM CTR WOOD BOX Size 1500x500x400 and as per drawing number 40-SPM-SH-00002/01				
150	200054180000	NO	65.000	65.00	31.03.23
	K.S.CHEM.T.R.W BOXES 2000X500X400MM K.S.CHEM.T.R.W BOXES 2000X500X400MM and as per drawing number 40-SPM-SH-00002 / 01				
160	200054220000	NO	360.000	360.00	31.03.23
	K.S.CHEM. T.R.W. BOXES 2500X400X400MM-SPL K.S.CHEM.T.R.W BOXES 2500X400X400MM and as per drawing number 40-SPM-SH-00002 / 01				

The offers should reach us 30 minutes before the time of opening of tenders. The offers will be opened at 14.30 hrs on the due date of tender in the presence of tenderers who have submitted their offer and who may like to be present for the tender opening.Late and delayed offers are liable to be rejected.

Yours faithfully,
For **BHARAT HEAVY ELECTRICALS LIMITED**

R. KILLIVALAVAN
Senior Engineer / MANAGER / PURCHASE
PURCHASE / PSS / MM (FOSSIL BOILERS)
BHEL, TRICHY - 620 014
Yours faithfully,

BHARAT HEAVY ELECTRICALS LIMITED

Page
3/8



(A Government of India Undertaking)
HIGH PRESSURE BOILER PLANT
PURCHASE DEPARTMENT - FOSSIL BOILERS
THIRUCHIRAPALLI - 620014
TAMILNADU (INDIA)

PHONE :0431-2574737
GRAMS : BHARATELEC
FAX NO: 0431-2520719
E-mail: pramila@bhel.in
Web:

1902200001 / 28.01.2022

23505

170	200054240000	NO	150.000	150.00	31.03.23
	200X200X200 MM K.S.CHEM. T.R.W. BOXES 200X200X200 mm , (TYPE - SPE) and as per BHEL drawing number 40-SPM-SH-00001/01				
180	200054250000	NO	155.000	155.00	31.03.23
	K.S.CHEM.T.R.W BOXES 1100X300X300MM CTR WOOD BOX Size 1100x300x300 and as per drawing number 3-SH-B-004/B, Rev.No. 01				
190	200054390000	NO	45.000	45.00	31.03.23
	Type SPR - Size 850X630X670 Box K.S.CHEM.T.R.W BOXES 850X630X670mm , Type : SPR and as per BHEL Drawing Number 20-SPM-SH-00003/01				
200	200054450000	NO	120.000	120.00	31.03.23
	Type SPY - Size 450X200X200 Box K.S.CHEM.T.R.W BOXES 450X200X200mm , Type : SPY and as per BHEL Drawing Number 40-SPM-SH-00001/01				
210	200150300000	NO	620.000	620.00	31.03.23
	CTR WOOD BOX T-3 CTR WOOD BOX Type T-3 and as per drawing number 2-V-0000-05779 /02				
220	200150320000	NO	1680.000	1,680.00	31.03.23
	CTR WOOD BOX T-2 CTR WOOD BOX T-2 and as per drawing number 4-V-4000-07183 / 02				
230	200150330000	NO	1680.000	1,680.00	31.03.23
	CTR WOOD BOX T-1 Chem.T.R.W. Boxes -TYPE 1 and as per drawing number 4-V-4000-07183 / 02				
240	200150740000	NO	450.000	450.00	31.03.23
	CTR WOOD BOX T-23 CTR WOOD BOX Type T-23 and as per drawing number 1-V-0000-11136/04				
250	200150750000	NO	450.000	450.00	31.03.23
	CTR WOOD BOX T-24 CTR WOOD BOX Type T-24 and as per drawing number 1-V-0000-11136/04				
260	200150780000	NO	450.000	450.00	31.03.23
	CTR WOOD BOX T-27 CTR WOOD BOX Type T-27 and as per drawing number 1-V-0000-11136/04				

The offers should reach us 30 minutes before the time of opening of tenders.
The offers will be opened at 14.30 hrs on the due date of tender in the presence of
tenderers who have submitted their offer and who may like to be present for the tender
opening.Late and delayed offers are liable to be rejected.

Yours faithfully,
For **BHARAT HEAVY ELECTRICALS LIMITED**

R. KILLIVALAVAN
Senior Engineer
PURCHASE / PSS / MM
BHEL, TRICHY - 620 014.

R. Killivalavan
MANAGER / PURCHASE
(FOSSIL BOILERS)
Yours faithfully,

BHARAT HEAVY ELECTRICALS LIMITED

Page
4/8



(A Government of India Undertaking)
HIGH PRESSURE BOILER PLANT
PURCHASE DEPARTMENT - FOSSIL BOILERS
THIRUCHIRAPALLI - 620014
TAMILNADU (INDIA)

PHONE :0431-2574737
GRAMS : BHARATELEC
FAX NO: 0431-2520719
E-mail: pramila@bhel.in
Web:

1902200001 / 28.01.2022

23505

Item No	Description	Quantity	Rate	Amount	Delivery Date
270	200150790000 CTR WOOD BOX T-28 CTR WOOD BOX Type T-28 and as per drawing number 1-V-0000-11136/04	NO	450.000	450.00	31.03.23
280	200150800000 CTR WOOD BOX T-4 CTR WOOD BOX Type T-4 and as per drawing number 2-V-0000-05779 /02	NO	730.000	730.00	31.03.23
290	200150820000 CTR WOOD BOX T-6 CTR WOOD BOX Type T-6 and as per drawing number 2-V-0000-05779 /02	NO	995.000	995.00	31.03.23
300	200150830000 CTR WOOD BOX T-7 CTR WOOD BOX Type T-7 and as per drawing number 2-V-0000-05779/02	NO	450.000	450.00	31.03.23
310	200150840000 CTR WOOD BOX T-10 CTR WOOD BOX Type T-10 and as per drawing number 2-V-0000-05779 /02	NO	450.000	450.00	31.03.23
320	200150880000 CTR WOOD BOX T-15 CTR WOOD BOX Type T-15 and as per drawing number 2-V-0000-05779/02	NO	150.000	150.00	31.03.23
330	200150930000 CTR WOOD BOX T-11 CTR WOOD BOX Type T-11 and as per drawing number 2-V-0002-05780	NO	120.000	120.00	31.03.23
340	200150940000 CTR WOOD BOX T-12 CTR WOOD BOX Type T-12 and as per drawing number 2-V-0003-05780	NO	280.000	280.00	31.03.23
350	200150950000 CTR WOOD BOX T-14 CTR WOOD BOX Type T-14 and as per drawing number 2-V-0000-05779/02	NO	120.000	120.00	31.03.23
360	200150970000 CTR WOOD BOX T-17 CTR WOOD BOX Type T-17 and as per drawing number 2-V-0005-05780/00	NO	150.000	150.00	31.03.23
370	200151000000 CTR WOOD BOX T-52 CTR WOOD BOX Type T-52 and as per drawing number 2-V-4600-03636/08	NO	800.000	800.00	31.03.23
380	200151010000 CTR WOOD BOX T-53 CTR WOOD BOX Type T-53 and as per drawing number 2-V-4600-03636/08	NO	450.000	450.00	31.03.23
390	200151060000 CTR WOOD BOX T-54 TR WOOD BOX Type T-54 and as per drawing	NO	200.000	200.00	31.03.23

The offers should reach us 30 minutes before the time of opening of tenders.
The offers will be opened at 14.30 hrs on the due date of tender in the presence of tenderers who have submitted their offer and who may like to be present for the tender opening. Late and delayed offers are liable to be rejected.

Yours faithfully,
For **BHARAT HEAVY ELECTRICALS LIMITED**

R. KILLIVALAVAN
Senior Engineer
PURCHASE / PSS / MM
BHEL, TRICHY - 620 014.

MANAGER / PURCHASE
(FOSSIL BOILERS)
Yours faithfully,

BHARAT HEAVY ELECTRICALS LIMITED

Page
5/8



(A Government of India Undertaking)
HIGH PRESSURE BOILER PLANT
PURCHASE DEPARTMENT - FOSSIL BOILERS
THIRUCHIRAPALLI - 620014
TAMILNADU (INDIA)

PHONE :0431-2574737
GRAMS : BHARATELEC
FAX NO: 0431-2520719
E-mail: pramila@bhel.in
Web:

1902200001 / 28.01.2022

23505

400	number 2-V-4600-03636/08 200151080000 CTR WOOD BOX T-1A CTR WOOD BOX T-1A and as per drawing number 4-V-4000-07183 / 02	NO	680.000	680.00	31.03.23
410	200151090000 CTR WOOD BOX T-56 CTR WOOD BOX Type T-56 and as per drawing number 2-V-4600-03636/08	NO	450.000	450.00	31.03.23
420	200151110000 CTR WOOD BOX T-58 CTR WOOD BOX Type T-58 and as per drawing number 2-V-4600-03636/08	NO	600.000	600.00	31.03.23
430	200151120000 CTR WOOD BOX T-61 CTR WOOD BOX Type T-61 and as per drawing number 1-V-0000-11136/04	NO	250.000	250.00	31.03.23
440	200151130000 CTR WOOD BOX T-62 CTR WOOD BOX Type T-62 and as per drawing number 2-V-7503-10122	NO	250.000	250.00	31.03.23

This Enquiry shall be monitored by below Independent External Monitor

Shri Arun Chandra Verma,IPS (Retd.)
Flat No. C -1204,
C Tower, Amrapali,
Platinum Complex,
Sector 119, Noida (U.P.).
Ph: + 91 8130386387
acverma1@gmail.com

Shri Virendra Bahadur Singh, IPS (Retd.)
H. No. B-5/64, Vineet
Khand, Gomti Nagar,
Lucknow - 226010.
Ph: + 91 8853760730
9818377360
vbsinghips@gmail.com

General Note:

The offers should reach us 30 minutes before the time of opening of tenders.
The offers will be opened at 14.30 hrs on the due date of tender in the presence of
tenderers who have submitted their offer and who may like to be present for the tender
opening.Late and delayed offers are liable to be rejected.

Yours faithfully,
For **BHARAT HEAVY ELECTRICALS LIMITED**

R. KILLIVALAVAN
Senior Engineer
PURCHASE / PSS / MM
BHEL, TRICHY - 620 014.
R. Killivalavan
MANAGER / PURCHASE
(FOSSIL BOILERS)
Yours faithfully,

BHARAT HEAVY ELECTRICALS LIMITED

Page
6/8



(A Government of India Undertaking)
HIGH PRESSURE BOILER PLANT
PURCHASE DEPARTMENT - FOSSIL BOILERS
THIRUCHIRAPALLI - 620014
TAMILNADU (INDIA)

PHONE :0431-2574737
GRAMS : BHARATELEC
FAX NO: 0431-2520719
E-mail: pramila@bhel.in
Web:

1902200001 / 28.01.2022

23505

The bidder along with its associate/ collaborators/ sub-contractors/ sub-vendors/ consultants/ service providers shall strictly adhere to BHEL fraud prevention policy displayed on BHEL website <http://www.bhel.com> and shall immediately bring to the notice of BHEL management about any fraud or suspected fraud as soon as it comes to their notice.

Goods and Service Tax (GST)

Indigenous suppliers:

1. Response to Tenders for Indigenous supplier will be entertained only if the vendor has a valid GST registration no which should clearly have mentioned in the offer. If any specific exemption is available, a declaration with due supporting documents need to be furnished for considering the offer. Supplier shall mention the HSN code for each item quoted by them in the offer.
2. Supplier shall mention their GSTN registration number in all their invoices and invoices shall be in the format as specified/prescribed under GST laws. Invoices shall necessarily contain Invoice number (in case of multiple numbering system is being followed for billing like SAP invoice no, commercial invoice no etc., then the Invoice No which is linked/uploaded in GSTN network shall be clearly indicated), item description as per PO, Quantity, Rate, Value, applicable taxes with nomenclature (like IGST, SGST, CGST & UTGST) separately, HSN/ SAC Code, etc.
3. All invoices shall bear the HSN Code for each item separately (Harmonized System of Nomenclature)/ SAC code (Services Accounting Code).
4. A declaration to the effect that all invoice particulars are/were uploaded in the GSTN network/ portal & all tax liability

The offers should reach us 30 minutes before the time of opening of tenders. The offers will be opened at 14.30 hrs on the due date of tender in the presence of tenderers who have submitted their offer and who may like to be present for the tender opening. Late and delayed offers are liable to be rejected.

Yours faithfully,
For **BHARAT HEAVY ELECTRICALS LIMITED**

R. KILLIVALAVAN
Senior Engineer
PURCHASE / PSS / MM
BHEL, TRICHY - 620 014

R. Killivalavan
MANAGER / PURCHASE
(FOSSIL BOILERS)
Yours faithfully,

BHARAT HEAVY ELECTRICALS LIMITED

(A Government of India Undertaking)

HIGH PRESSURE BOILER PLANT

PURCHASE DEPARTMENT - FOSSIL BOILERS

THIRUCHIRAPALLI - 620014

TAMILNADU (INDIA)

PHONE :0431-2574737

GRAMS : BHARATELEC

FAX NO: 0431-2520719

E-mail: pramila@bhel.in

Web:

Page
7/8



1902200001 / 28.01.2022

23505

as per GST rules and regulations have been and will be discharged, shall be mentioned in the invoice. If not mentioned in

the invoice, a separate declaration shall be submitted as per the requirement of BHEL.

5. All documents like Mill Test Certificate, LR copy, Guarantee/Warrantee certificate, work completion certificate, any

other document mentioned in PO, shall be sent along with the vehicle/consignment. For all consignments received within

the calendar month, input credit will be availed within that month in line with monthly returns filing cycle. In case of any

discrepancy in the document or non-submission of documents mentioned in the PO, then BHEL will not be able to accept

or account the material, in such case availing of tax credit will be deferred to next month or so.

6. In case of discrepancy in the data uploaded by supplier in the GSTN portal or in case of any shortages or rejection in

the supply, then BHEL will not be able to avail the tax credit and will notify the supplier of the same.

Supplier has to

rectify the data discrepancy in the GSTN portal or issue credit note (details to be uploaded in GSTN portal) for the

shortages or rejections in the supplies, within the calendar month notified by BHEL.

7. For any such delay in availing of tax credit for reasons attributable to supplier (as mentioned above), interest

(calculated @ SBI Base Rate + 6%) along with penalty if any will be deducted for the delayed period i.e. from the month

of receipt till the month tax credit is availed, from the running bills.

Import Suppliers:

1. Supplier shall mention the HSN code of each item quoted by them in the offer. The HSN shall be mentioned in the

Invoice also for each item without fail.

For this procurement, Public Procurement (Preference to Make in India), Order 2017 dated 15.06.2017 & 28.0.2018 and subsequent Orders issued by the respective Nodal Ministry shall be applicable even if issued after issue of this NIT but before finalization of contract / PO / WO against this NIT.

In the event of any Nodal Ministry prescribing higher or lower percentage of purchase and / or local content in respect of this procurement, same shall be applicable.

Default purchase preference shall be 20% to local suppliers with default minimum local content of 50%.

The bidder along with its associate / collaborators / sub-contractors / sub-vendors / consultants / Service providers shall strictly adhere to BHEL fraud prevention policy displayed on BHEL website <http://www.bhel.com> and shall immediately bring to the notice of BHEL management about any fraud or suspected fraud as soon as it comes to their notice.

Offers from Foreign vendors will not be considered. Offers of local vendors with less than the minimum local content as prescribed in this Tender will also not be considered. In the absence of any such information in the tender, the required minimum local content shall be 20%

The evaluation currency for this tender shall be **INR**.

Enclosures:

The offers should reach us 30 minutes before the time of opening of tenders. The offers will be opened at 14.30 hrs on the due date of tender in the presence of tenderers who have submitted their offer and who may like to be present for the tender opening. Late and delayed offers are liable to be rejected.

Yours faithfully,
For **BHARAT HEAVY ELECTRICALS LIMITED**

R. KILLIVALAVAN
Senior Engineer
PURCHASE / PSS / MM
BHEL, TRICHY - 620 014

R. Killivalavan
MANAGER / PURCHASE
(FOSSIL BOILERS)
Yours faithfully,



BHARAT HEAVY ELECTRICALS LIMITED

Page
8/8

(A Government of India Undertaking)
HIGH PRESSURE BOILER PLANT
PURCHASE DEPARTMENT - FOSSIL BOILERS
THIRUCHIRAPALLI - 620014
TAMILNADU (INDIA)

PHONE :0431-2574737
GRAMS : BHARATELEC
FAX NO: 0431-2520719
E-mail: pramila@bhel.in
Web:

1902200001 / 28.01.2022

23505

"LD clause has to be confirmed without fail."

The offers should reach us 30 minutes before the time of opening of tenders.
The offers will be opened at 14.30 hrs on the due date of tender in the presence of
tenderers who have submitted their offer and who may like to be present for the tender
opening. Late and delayed offers are liable to be rejected.

Yours faithfully,
For **BHARAT HEAVY ELECTRICALS LIMITED**

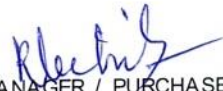
R. KILLIVALAVAN, Senior Engineer
PURCHASE PSS / MM
MANAGER / PURCHASE
(FOSSIL BOILERS)
Yours faithfully,
BHEL, TRICHY - 620 014.

ANNEXURE-I**Pre-Qualification Criteria for KILN SEASONED CHEMICALLY TREATED
RUBBER WOOD BOXES****The following points are to be confirmed by the supplier,**

Sl. No.	PARTICULARS	Bidder to confirm	Bidder's Reply
1.	The tendered items are reserved for exclusive procurement from MSE bidders as per the "Public Procurement Policy. Techno-commercially qualified MSE bidders will be considered for further processing. MSE vendor having Udyam certificate only eligible for participating this tender and should submitted along with offer(Part-I). Firm in process of obtaining MSE certificate / certification received after tender due date shall not be considered as MSE parties".	Attached / Not Attached	
2.	Bidders should quote for all sizes without fail. If bidder is not quoting any one of the items, their offers will not be considered for further processing and those bids will be summarily rejected.	Confirmed/ Not Confirmed	
3.	Material supply should be as per specification — CHEM:20/03	Confirmed/ Not Confirmed	
4.	Test certificates have to be supplied along with main supply	Confirmed/ Not Confirmed	
5.	Delivery period from the date of order within 45 days	Confirmed/ Not Confirmed	
6.	Bidders should submit the copy of one previous executed PO for supply of CTR wooden boxes on or after 01.01.2019 to any organization	Attached / Not Attached	

Note:

Offers meeting the above prequalification criteria points only will be evaluated further. Otherwise the offers will summarily be rejected.

Signature & Seal

ANNXURE-II		Enq.No.1902200001 DT:28.01.22		
Item	Material	Short Text	Drawing Number	Quantity
10	200054040000	K.S.CHEM.T.R.W BOXES 600X500X400MM	3-SH-B-004/C	180
20	200054050000	K.S.CHEM.T.R.W BOXES 900X600X600MM	2-SH-CRT-00002/B	490
30	200054060000	K.S.CHEM.T.R.W BOXES1200X900X600MM	2-SH-CRT-00002/B	550
40	200054070000	K.S.CHEM.T.R.W BOXES1300X900X900MM	2-SH-CRT-00002/B	480
50	200054080000	K.S.CHEM.T.R.W BOXES1500X700X700MM	2-SH-CRT-00002/B	330
60	200054090000	K.S.CHEM.T.R.W BOXES1050X1050X500MM	3-SH-B-004/C	160
70	200054100000	K.S.CHEM.T.R.W BOXES1600X900X1000MM	3-SH-B-005	315
80	200054110000	K.S.CHEM.T.R.W BOXES800X200X200MM	40-SPM-SH-00001/01	120
90	200054120000	K.S.CHEM.T.R.W BOXES 1500X200X200MM	40-SPM-SH-00001/01	60
100	200054130000	K.S.CHEM.T.R.W BOXES 2000X200X200MM	40-SPM-SH-00001/01	60
110	200054140000	K.S.CHEM.T.R.W BOXES 1100X200X200MM	3-SH-B-004 / B, Rev 01	120
120	200054150000	K.S.CHEM.T.R.W BOXES 1100X400X400MM	40-SPM-SH-00002/01	130
130	200054160000	K.S.CHEM.T.R.W BOXES 1500X500X400MM	40-SPM-SH-00002/01	120
140	200054170000	K.S.CHEM.T.R.W BOXES 2000X500X400MM	40-SPM-SH-00002 / 01	65
150	200054180000	K.S.CHEM.T.R.W BOXES 2500X400X400MM-SPL	40-SPM-SH-00002 / 01	65
160	200054220000	K.S.CHEM. T.R.W. BOXES 200X200X200 MM	40-SPM-SH-00001/01	360
170	200054240000	K.S.CHEM.T.R.W BOXES 1100X300X300MM	3-SH-B-004/B, Rev.No. 01	150
180	200054250000	K.S.CHEM.T.R.W BOXES 1100X500X500MM	3-SH-B-004/B/01	155
190	200054390000	Type SPR - Size 850X630X670 Box	20-SPM-SH-00003/01	45
200	200054450000	Type SPY - Size 450X200X200 Box	40-SPM-SH-00001/01	120
210	200150300000	CTR WOOD BOX T-3	2-V-0000-05779 /02	620
220	200150320000	CTR WOOD BOX T-2	4-V-4000-07183 / 02	1,680
230	200150330000	CTR WOOD BOX T-1	4-V-4000-07183 / 02	1,680
240	200150740000	CTR WOOD BOX T-23	1-V-0000-11136/04	450
250	200150750000	CTR WOOD BOX T-24	1-V-0000-11136/04	450
260	200150780000	CTR WOOD BOX T-27	1-V-0000-11136/04	450
270	200150790000	CTR WOOD BOX T-28	1-V-0000-11136/04	450
280	200150800000	CTR WOOD BOX T-4	2-V-0000-05779 /02	730
290	200150820000	CTR WOOD BOX T-6	2-V-0000-05779 /02	995
300	200150830000	CTR WOOD BOX T-7	2-V-0000-05779/02	450
310	200150840000	CTR WOOD BOX T-10	2-V-0000-05779 /02	450
320	200150880000	CTR WOOD BOX T-15	2-V-0000-05779/02	150
330	200150930000	CTR WOOD BOX T-11	2-V-0002-05780	120
340	200150940000	CTR WOOD BOX T-12	2-V-0003-05780	280
350	200150950000	CTR WOOD BOX T-14	2-V-0000-05779/02	120
360	200150970000	CTR WOOD BOX T-17	2-V-0005-05780/00	150
370	200151000000	CTR WOOD BOX T-52	2-V-4600-03636/08	800
380	200151010000	CTR WOOD BOX T-53	2-V-4600-03636/08	450
390	200151060000	CTR WOOD BOX T-54	2-V-4600-03636/08	200
400	200151080000	CTR WOOD BOX T-1A	4-V-4000-07183 / 02	680
410	200151090000	CTR WOOD BOX T-56	2-V-4600-03636/08	450
420	200151110000	CTR WOOD BOX T-58	2-V-4600-03636/08	600
430	200151120000	CTR WOOD BOX T-61	1-V-0000-11136/04	250
440	200151130000	CTR WOOD BOX T-62	2-V-7503-10122	250
SPLITTING WILL NOT BE APPLICABLE IN CAE ITEM QTY LESS THAN 100 nos.				



**SPECIFICATION FOR
PACKING WOOD –
RUBBER WOOD**

Doc. No. PR: CHEM: 20

Rev. No.: 03

Date: 15.11.2005

1.0 SCOPE:

This specification prescribes the requirements of rubber wood intended for packing purposes.

2.0 DEFINITION:

RUBBER WOOD – Seasoned and chemically treated rubber wood in converted form (scantlings, boxes / shooks) intended for packing cases to be stored outside and exposed.

3.0 REQUIREMENTS:

3.1 Supply of planks to shipping / FB shall be with one side planing, joint planed and two longitudinal edges prepared for lap joints of 12.5 mm on opposite sides.

3.2 The rubber wood to be supplied shall be seasoned as per IS 1141 – 1993, “SEASONING OF TIMBER – CODE OF PRACTICE”.

3.3 The process for chemical preservative treatment shall be as per IS 401 – 2001, “PRESERVATION OF TIMBER - CODE OF PRACTICE”.

3.4 For chemical treatment, the preservative chemicals used shall be Copper, Chrome, and Boron (CCB) composition.

3.5 DIMENSIONS AND ITS TOLERANCE:

3.5.1 Dimensions shall be as specified in Purchase Order.

3.5.2 The dimensional tolerance shall be as follows:

Length : ± 10 mm

Width : ± 4 mm

Thickness : ± 3 mm for thickness up to 30 mm
: ± 4 mm for thickness above 30 mm

Bow : ± 4 mm per 300 mm



**SPECIFICATION FOR
PACKING WOOD –
RUBBER WOOD**

Doc. No. PR: CHEM: 20

Rev. No.: 03

Date: 15.11.2005

3.6 FREEDOM FROM DEFECTS:

3.6.1 Planks, Scantlings, Battens shall be free from defects like cracks, bends and knots.

3.7 The material shall also comply with the requirements given in Table – 1.

Table – 1 REQUIREMENTS FOR RUBBER WOOD

S. No.	Characteristics	Requirement
1	Species	Rubber
2	Chemical depth penetration Test	6.0 mm, (min)

ANNEX C

(Clause 9.2)

METHOD FOR THE DETERMINATION OF MOISTURE CONTENT

C-1 TEST SAMPLE

C-1.1 Baulks and Scantlings

If the timber is in baulks and scantlings, that is, of cross-sections greater than 5 × 5 cm, a boring taken about 30 cm away from an end and roughly in the middle of any side shall constitute the test sample.

C-1.2 Planks

If the timber is in planks of thickness 2.5 cm or less, a section 2.5 cm long, taken at about 30 cm from an end, shall constitute the test sample.

C-1.3 Green Timber

In the case of a charge of evenly dried or green timber of the same species, about a dozen samples shall be taken for obtaining the average moisture content.

C-2 PROCEDURE

C-2.1 The test sample, immediately after it has been

bored or cut from the timber, is placed in a tared weighing bottle; the bottle with the sample in it is weighed and then placed with the stopper removed in an oven set at 103 ± 2°C. After 24 hours of drying, the bottle is taken out, stoppered, and cooled to the atmospheric temperature in a desiccator and weighed.

C-3 CALCULATION

C-3.1 The moisture content, in percent, shall be calculated as follows:

$$\text{Moisture content} = \frac{B - C}{C - A} \times 100$$

where

B = mass of the weighing bottle (including stopper) with sample before drying,

C = mass of the weighing bottle (including stopper) with sample after oven drying, and

A = mass of the weighing bottle (including stopper).

ANNEX D

(Clause 9.5)

METHOD FOR THE DETERMINATION OF PENETRATION OF PRESERVATIVE

D-1 GENERAL

Methods for the determination of penetration of copper-chrome-arsenic composition, zinc chloride and acid-cupric-chromate composition are given below. 'Definite colour reactions are not given by other common preservatives.

D-2 COPPER-CHROME-ARSENIC COMPOSITION, ACID-CUPRIC-CHROMATE COMPOSITION, BORATED-COPPER-CHROME-ARSENIC COMPOSITION AND AMMONIACAL-COPPER-ARSENITE COMPOSITION

D-2.1 Detection for Copper

D-2.1.1 Dissolve 0.5 g chrome Azurol-S and 5.0 g of sodium acetate in 80 ml water and dilute to 100 ml.

D-2.1.2 Spray the solution over split section or boring with a fine spray on the cut surface of treated wood. A deep blue colour shows the presence of copper.

D-2.2 Detection for Chromium

D-2.2.1 Dissolve 0.5 g diphenyl carbazide in 50 ml isopropyl alcohol and 50 ml of distilled water.

D-2.2.2 Spray the solution on the boring or cross section of treated wood. Portions containing chromium will develop a purple colour while unpenetrated portion will remain as such.

D-2.3 Detection for Arsenic

D-2.3.1 Solution 1

3.5 g ammonium molybdate dissolved in 90 ml distilled water followed by 9 ml concentrated nitric acid.

D-2.3.2 Solution 2

0.7 g benzidine dihydrochloride dissolved in 10 ml concentrated acetic acid and diluted to 100 ml by adding 90 ml distilled water.

TEST CERTIFICATE FOR RUBBER WOOD (MODEL FORMAT)

Test report no.:XXX/dated DD-MM-YY

DC No.XXX/Dated DD-MM-YY

1	NAME OF THE FIRM	
2	PO NO. & DATE	
3	NAME OF THE CUSTOMER	BHEL,TRICHY
4	MATERIALS	CHEMICALLY TREATED RUBBER WOOD
5	QUANTITY & SIZE DETAILS	AS PER DC NO.XXX/DATED DD-MM-YY
6	SPECN TO WHICH MATERIALS SUPPLIED	PR:CHEM:20/03
7	DIMENSION REPORT	AS SPECIFIED IN PR:CHEM:20/03, CI.3.5
8	NAME OF THE SPECIES IDENTIFIED (TRADE NAME)	RUBBER WOOD
9	DATE OF SEASONING / TYPE OF SEASONING	DD-MM-YY / KILN SEASONING
10	PERCENTAGE OF MOISTURE CONTENT IN SEASONED WOOD BEFORE CHEMICAL TREATMENT (TEST AS PER IS:401,ANNEX-C)	XX%
11	DATE OF CHEMICAL TREATMENT	
12	TYPE OF CHEMICAL TREATMENT FOLLOWED	PRESSURE TYPE/ VACUUM IMPREGNATION (tick as applicable)
13	TYPE OF CHEMICAL PRESERVATIVES USED	Copper-Chromium-Born (C.C.B)
14	DEPTH OF PENETRATION OF PRESERVATIVE CHEMICALS, mm	___mm (as per PR:CHEM:20/03, CI 3.7
	Presence of copper (test as per IS:401, Annex D)	Present
	Presence of Chromium (Test as per IS:401, Annex D)	Present
	Presence of Boron (Test as per IS:401, Annex D)	Present
15	PERCENTAGE OF MOISTURE CONTENT AFTER CHEMICAL TREATMENT (Test as per IS:401, Annex C)	Xx% (when dispatched)
16	Certified that the above supply conforms to the specification. PR:CHEM: 20/03.	

Signature of quality inspector with seal



Enq.No.1902200001

BHARAT HEAVY ELECTRICALS LIMITED
(A Government of India Undertaking)
Purchase/MM/PSS
TIRUCHIRAPALLI-620014

ANNEXURE A

I. GENERAL CONDITIONS:

- 1) Bidders are requested to quote their offer price on F.O.R Destination (BHEL/Trichy--Stores) basis only (The basic price of the material quoted in the bid should be inclusive of Packing, Forwarding, freight and transit insurance, etc.).
Ex-works offers will be summarily rejected without further clarification.
- 2) No charges shall be indicated as "Lumpsum" or "Approximate" in absolute value. All charges like taxes and duties should be clearly specified as "percentage" of the quoted rates.
- 3) If GST is payable as extra to the quoted price should be specifically stated in quotations failing which the purchaser will not be liable for payment of GST. Our GST No. is **33AAACB4146P2ZL**.
- 4) Manufacturer's name, trademark or patent no. if any should be specified. Illustrative leaflets giving technical particulars are required along with quotation wherever necessary.
- 5) Products with I.S.I. certification marks will be preferred.
- 6) The Purchaser shall be under no obligation to accept the lowest or any other tender and shall be entitled to accept in Part or full without assigning any reason whatsoever.
- 7) The bidder has to keep track of any changes by viewing the addendum / Corrigendum's issued by the Purchaser on time-to- time basis in the etender_nic platform. The Company calling for tenders shall not be responsible for any claims/problems arising out of this.
- 8) The user should complete all the processes and steps required for bid submission. The successful bid submission can be ascertained once acknowledgement is given by the system through bid submission number after completing all the processes and steps. BHEL and etender_nic portal will not be responsible for incomplete bid submission by users. Users may also note that the incomplete bids will not be saved by the system and are not available for the Purchaser for processing.
9. Before uploading scanned documents if any, the bidders shall sign on all the statements, documents, certificates uploaded by him, owning responsibility for their correctness / authenticity.

Offer Submission:

- a) This Tender is hosted in EPS portal & offer to be submitted through EPS portal only. You are requested to submit your 2 parts offer before due date & time of the enquiry through NIC (<https://eprocurebhel.co.in>) only. SEALED COVER BIDS / E-MAILS / FAX / MANUAL OFFERS WILL NOT BE ACCEPTED.
- b) Offer is to be submitted in TWO part bids system (Technical bid + Price bid) in the E-Procurement NIC PORTAL (<https://eprocurebhel.co.in>) ONLY.
- c) Before uploading scanned documents if any, the bidders shall sign on all the statements, documents, certificates uploaded by him, owning responsibility for their correctness / authenticity
- d) At its option, BHEL may consider extending the due date/s for the tender openings. Sufficient notice would be given by BHEL for such extensions and it will be published as corrigendum in following websites,
<https://eprocurebhel.co.in>
<http://www.bhel.com/tender/>
- e) **Authorization for participation in EPS portal through DSC: E-Tender. Participation requirements:**
Vendor shall register their Digital Signature Certificate (DSC) (Class 3- SHA2- 2048 BIT- SIGNING & ENCRYPTION). Suppliers are advised to go through the FAQ available in the web portal (<https://eprocurebhel.co.in>). DSC shall be registered for the authorized person and all transaction done using that DSC against our tenders shall be taken as valid communication and shall be binding on vendor and is valid legally.

II. TERMS AND CONDITIONS OF THE ENQUIRY

1. Offers should have a validity of minimum 120 days from the date of technical bid opening.
2. Conditional offers are likely to be rejected.
3. The offer should be submitted in two parts (Part-I—Techno commercial Bid) and (Part-II—Price Bid) before the due date and time mentioned in NIC.
4. On the due date of tender opening, only technical bids will be opened. The opened technical bids will be evaluated by us and clarifications required if any, will be called for from the bidders on technical and commercial points. If no reply is received from the supplier for the clarification raised by BHEL with in the final cut-off date those suppliers offer will be processed with the documents available / submitted against this tender. Offers not meeting the required specification and technical condition will be summarily rejected. The price bids of technically suitable bidders will be opened on a later date with prior intimation to techno-commercially suitable bidders.
5. **Rate Submission:** Bidders are requested to quote their offer price on F.O.R Destination (BHEL/Stores) basis only (The basic price of the material quoted in the bid should be inclusive of Packing, Forwarding, freight and transit insurance, Assembling of boxes etc.). Other delivery conditions like Ex-works / Ex-Godown/ Transportation of materials through transport carriers from your works up to the transport carrier's office at Tiruchy and taking delivery of goods by BHEL from such office of transport carriers is not acceptable to us and such offers will be summarily rejected. No charges shall be indicated as "Lumpsum" or "Approximate" in absolute value. All charges like taxes and duties should be clearly specified as "percentage" of the quoted rates.
6. The offer will be evaluated based on the quote submitted by bidders at the time of Technical bid opening.



- 7. Ranking:** In the event of more than one vendor becoming L1 for any of the item / items, discounted offer will be invited for arriving L1. Even after getting discounted offer, if more than one vendor becomes L1, lot system will be operated for arriving final L1.
- 8. Price Revision:** No revision of prices shall be entertained at any circumstances after tenders are opened. The quoted/Finalized rate shall be firm till completion of Frame Work PO quantity.

9. REVERSE ACTION (RA) :-

BHEL shall be resorting to Reverse Auction (RA) (Guidelines as available on www.bhel.com) for this tender. RA shall be conducted among the techno-commercially qualified bidders. Price bids of all techno-commercially qualified bidders shall be opened and same shall be considered for RA. In case any bidder(s) do(es) not participate in online Reverse Auction, their sealed envelope price bid along with applicable loading, if any, shall be considered for ranking.

10. ORDER SHARING RATIO:

- Splitting of quantity is applicable for item quantity of 100 & above nos. For quantities 99 & below nos, split will not be applicable.
 - In case of 1 or 2 qualified vendor-100% quantity goes to L1
 - In case of 3 qualified vendors,L1 -70% qty,L2-30% qty
 - In case of 4 qualified vendors,L1-50%qty, L2-30% qty & L3-20% qty.
 - if offer is not accepted by any one, it will be extended to other rankers (except H1) till reaches maximum three vendors with respect to the above splitting
- After counter offering, unaccepted counter quantity will be placed to L1 vendors.
- 11.** BHEL reserves the right to negotiate with L1 supplier or re-float the tender for items where, L1 price is not the lowest acceptable price. BHEL reserves the right to increase or decrease the tender quantity.

12. FA & PO Placing

The quantities indicated in this tender are tentative annual requirement of BHEL. Frame work agreement will be entered with successful L1 & counter offer accepted vendors with one year validity. PO will be placed for actual requirements on monthly basis.

BHEL reserves the right to place order as mentioned in the split up ratio on monthly basis and delivery period is 45 days from the date of order.

In case of failure in supplying the items as per PO terms and conditions within the delivery period, BHEL reserves the right to cancel the PO and distribute their balance quantity (both PO & FA) equally among the other vendors who qualified as per the split up ratio. Also such failed vendors will be removed from Frame work Contract of this Enquiry and Suspension of Business Dealings applicable for failure to execute the contract as per BHEL terms & conditions.

13. Payment Terms:-

Payments for MSE Indigenous vendors will be as MSMED Act, 2006 after acceptance of materials.

Any deviation in the payment terms, any other conditions in payment terms or any other payment terms will not accepted and offer will not be considered.

(Bills will be forwarded to finance only after assembling the boxes against written mail confirmation from ward-14 about completion of assembly of boxes).

14. LIQUIDATED DAMAGES (LD) Staggered delivery schedule

In case of staggered delivery schedule, if the Supplier fails to deliver the quantity of any line item of the P.O within the period specified in that line item, Purchaser shall deduct Liquidated Damages, 0.5% of the undelivered portion per week delay or part thereof subject to maximum of 10% of the total order value.

Loading Criteria on LD term for arriving the L1 rate:

Any deviation on BHEL LD clause, loading (Offered Value) will be applied to the extent to which it is not agreed by the bidder. *Acceptance of LD on undelivered portion will be loaded at the rate of 10% (max).

15. RISK PURCHASE:

"Alternatively the purchaser at his option will be entitled to terminate the contract and to purchase elsewhere at the risk and cost of the seller either the whole of the goods or any part which the supplier has failed to deliver or dispatch within the time stipulated as aforesaid or if the same were not available, the best and the nearest available substitutes therefor. The supplier shall be liable for any loss, which the purchaser may sustain by reason of such risk purchases in addition to penalty at the rate mentioned in LD clause above."

- In the event of any successful Tenderer's failure to fulfil any of the tender / Contract obligations as per Contract / Agreement, BHEL may purchase from the alternate vendor and get it completed to meet the BHEL requirement and additional expenditure, if any, including consequential cost viz., demurrage etc., will be fully recovered from the supplier who failed to supply the items with the due date.
- The decision of BHEL with regard to the actual losses / consequential expenditure incurred by BHEL shall be final and binding on the supplier.

The value under Risk purchase clause shall be calculated as follows:

$$\text{Risk \& Cost Amount} = [(A-B) + (A \times H/100)]$$

Where,

A= Value of Balance scope of Work/ Supply (*) as per rates of new contract

B= Value of Balance scope of Work/ Supply (*) as per rates of old contract being paid to the contractor/ supplier at the time of termination of contract i.e. inclusive of PVC & ORC, if any.

H = Overhead Factor shall be taken as 5

In case (A-B) is less than 0 (zero), value of (A-B) shall be taken as 0 (zero).



*(Balance scope of work/ supply)

Difference of Tendered/Contract Quantities and Executed Quantities as on the date of issue of Letter for 'Termination of PO/Contract', shall be taken as balance scope of Supply for calculating risk & cost amount.

In case vendor fails to fulfil any of the PO / Contract obligations as per PO/Contract, PO/contract shall be cancelled and appropriate cost shall be deducted from the vendor's pending bills in BHEL Trichy (or) across the BHEL units.

16. GST DETAILS:

- Response to Tenders for Indigenous supplier will be entertained only if the vendor has a valid GST registration No (GSTIN) which should be clearly mentioned in the offer. If the dealer is exempted from GST registration, a declaration with due supporting documents need to be furnished for considering the offer. Dealers under composition scheme should declare that he is a composition dealer supported by the screen shot taken from GST portal. The dealer has to submit necessary documents if there is any change in status under GST.
- Supplier shall mention their GSTIN in all their invoices (incl. credit Notes, Debit Notes) and invoices shall be in the format as specified/prescribed under GST laws. Invoices shall necessarily contain Invoice number (in case of multiple numbering system is being followed for billing like SAP invoice no, commercial invoice no etc., then the Invoice No. which is linked/uploaded in GSTN network shall be clearly indicated), Billed to party (with GSTIN) & Shipped to party details, item description as per PO, Quantity, Rate, Value, applicable taxes with nomenclature (like IGST, SGST, CGST & UTGST) separately, HSN/ SAC Code, Place of Supply etc.
- All invoices shall bear the HSN Code for each item separately (Harmonized System of Nomenclature)/ SAC code (Services Accounting Code).
- Invoices will be processed only upon completion of statutory requirement and further subject to following:
 - Vendor declaring such invoice in Form GST ANX-1
 - Receipt of Goods or Services and Tax invoice by BHEL
- As the continuous uploading of tax invoices in GSTN portal (in GST ANX-1) is available for all (i.e. both Small & Large) tax payers under proposed new GST Return System, all invoices raised on BHEL may be uploaded immediately in GST portal on despatch of material /rendering of services. The supplier shall ensure availability of Invoice in GST portal before submission of invoice to BHEL. Invoices will be admitted by BHEL only if the invoices are available in GSTN portal (in BHEL's GST ANX-2).
- In case of discrepancy in the data uploaded by the supplier in the GSTN portal or in case of any shortages or rejection in the supply, then BHEL will not be able to avail the tax credit and will notify the supplier of the same. Supplier has to rectify the data discrepancy in the GSTN portal or issue credit note or debit note (details also to be uploaded in GSTN portal) for the shortages or rejections in the supplies or additional claims, within the calendar month informed by BHEL.
- In cases where invoice details have been uploaded by the vendor but failed to remit the GST amount to GST Department (Form PMT-08 or Form GST RET-01 to be submitted) within stipulated time, then GST paid on the invoices pertaining to the month for which GST return not filed by the vendor will be recovered from the vendor along with the applicable interest (currently 24% p.a) and all subsequent bills of the vendor will not be processed till filing of the GST return by the vendor
- In case GST credit is denied to BHEL due to non-receipt or delayed receipt of goods and/ or tax invoice or expiry of timeline prescribed in GST law for availing such ITC, or any other reasons not attributable to BHEL, GST amount claimed in the invoice shall be disallowed to the vendor.
- Where any GST liability arising on BHEL under Reverse Charge (RCM), the vendor has to submit the invoices to BHEL well within the timeline prescribed in GST Law, to enable BHEL to discharge the GST liability. If there is a delay in submission of invoice by the vendor resulting in delayed payment of GST by BHEL along with Interest, then such Interest payable or paid shall be recovered from the vendor.
- Under GST regime, BHEL has to discharge GST liability on LD recovered from suppliers/contracts. Hence applicable GST shall also be recoverable from suppliers/contractors on LD amount. For this Tax Invoice will be issued by BHEL indicating the respective supply invoice number.
- GST TDS will be deducted as per Section 51 of CGST Act 2017 and in line with Notification 50/2018 – Central Tax dated 13.09.2018. GST TDS certificate which will be generated in GST portal subsequent to vendor accepting the TDS deduction in the GST portal, will be issued to the vendor.
- GST CREDIT: Suppliers are advised to get registered to GSTN portal. Tenderer under "GST credit" shall be preferred.

17. PROVISIONS FOR MICRO AND SMALL ENTERPRISES (MSE) BIDDERS:

- a) Only MSE suppliers can participate the offer if they submit Udyam registration certificate along with the offer.
- b) In case of any change in the MSE status of the bidder, it shall be the responsibility of the bidder to notify the change as a part of the bid document. If at a later date it comes to the knowledge of BHEL, that the change in the status has not been intimated by the bidder and the order is obtained under the premise of an MSE then BHEL would cancel the pending order against this tender and take necessary steps for suspension of the business dealing with the bidder as per the procurement policy of BHEL.
- c) Non submission of Udyam registration certificate will lead to consideration of Non MSE supplier and not eligible for further evaluation of submitted offer.



d) As per MSME Memorandum dt.09.02.2017, Traders and Agents are not covered under the definition of Micro and Small Enterprises. They are not allowed to avail the benefits extended under the MSE category and their offer will not be considered for evaluation.

18. Preference to Make in India:

- Public Procurement (Preference to Make in India), order 2017 dated 15.06.2017 & 28.05.2018 & 04.06.2020 & 16.09.2020 (as applicable) and subsequent orders issued by the respective Nodal ministry shall be applicable even if issued after issue of this NIT but before finalization of contract/PO/WO against this NIT. In the event of any Nodal Ministry prescribing higher or lower percentage of purchase preference and/ or local content in respect of this procurement, same shall be applicable. Default margin of purchase preference shall be 20% to local suppliers with default minimum local content of 50%.
- The local content to categorize a supplier as a Class I local supplier/ Class II local supplier/ Non-Local supplier and purchase preference to Class I local supplier, is as defined in Public Procurement (Preference to Make in India), Order 2017 dated 04.06.2020 & 16.09.2020 (as applicable) issued by DPIIT. In case of subsequent orders issued by the nodal ministry, changing the definition of local content for the items of the NIT, the same shall be applicable even if issued after issue of this NIT, but before opening of Part_II bids against this NIT.
- Only Class-I and Class –II local suppliers as per MII order dated 04.06.2020 will be eligible to bid. Non-Local suppliers as per MII order dated 04.06.2020 are not eligible to participate.

19. Packing and Delivery:

- a) The supplier shall arrange for securely protecting and packing the materials in bundles to avoid loss or damages during transit. Each bundle shall consist all six shook's for making one box.
- b) In case of any quality rejection of materials, the supplier has to collect the materials at his own cost within the 15 days of rejection of advice. Otherwise the materials will be scrapped by BHEL.
- c) Unloading at BHEL has to be done by the suppliers and BHEL will not be in a position to provide any handling / unloading facilities.
- d) BHEL Name, Supplier Name, DC No. & Date shall be stenciled on all sides of shooks supplied to BHEL.

20. Assembling Of Boxes

- a) The boxes are to be assembled within 7 working days from the date of acceptance materials.
- b) The dimensions of the top, bottom and side girth battens shall be as per the relevant drawing.
- c) The thickness of the POLY ETHYLENE SHEET shall be 150 microns and more.

If supplier is not meeting the above 3 points, their boxes will be rejected despite they pass chemical test.

21. The correspondences between the bidder and BHEL through email are considered as valid document legally though not signed. It is treated as valid confirmations made on behalf of the respective company and comes under the legal ambit of the business transaction and hence binding on both the parties.
22. Disclaimer Clause: Neither the Organization (Bharat Heavy Electricals Ltd.) nor the service provider (**eprocurebhel**) is responsible for any failure of submission of bids due to failure of internet or other connectivity problems or reasons thereof.
23. Bidders participating in the tender should declare in their technical bid whether they have been black-listed / kept on hold / given Business holiday for a specified period by any Public Sector Undertaking or Government Departments. The reasons for such action with details and the current status of such hold shall be clearly furnished to BHEL. If no such details are mentioned in the offer, it will be construed that the bidder is not under any such hold. However, at a later date if it comes to the notice of BHEL about any such hold under enforcement, BHEL reserves the right to reject the offer at any point of time and also under any stage of the finalization of the tender. Such bidders will not be permitted to participate in the further tender proceedings and will be communicated suitably.
24. Unloading at BHEL has to be done by the suppliers and BHEL will not be in a position to provide any handling / unloading facilities.
25. Bidders not confirming to the enquiry specifications will be disqualified.
26. If Guarantee / Warranty period (is applicable) as per tender specification, No deviation permitted and deviated offers are liable for rejection.
27. **No revision of prices will be entertained up to evaluation after technical bid of the tenders are opened.**
28. For verification of data submitted towards evaluation of bidder's capability, BHEL may decide to visit the bidder(s) works. Any fact found deviating from submitted data shall make the bidder liable to be disqualified.
29. Any other conditions which might have been quoted by the seller and are in contravention to the terms and prescribed in the enquiry and which have not been specifically accepted by purchaser will not be applicable to the contract.
30. Lowest price received against BHEL tenders need not be the technically acceptable one and in that case BHEL reserves the right not to consider the same. The purchaser shall be under no obligation to accept the lowest or any other tender and shall be entitled to accept or reject any tender in part or full without assigning any reason whatsoever.
31. Any techno commercial clarifications/request for tender due date extensions with valid acceptable reasons to be addressed to BHEL prior to 48 hours of tender due date. BHEL reserves the right to extend the due date as per their discretion.



- 32.** The bidder has to keep track of any changes by viewing the addendum / Corrigendum's issued by the Purchaser on time-to- time basis in the E-Procurement platform. The Company calling for tenders shall not be responsible for any claims/problems arising out of this.
- 33. ARBITRATION:**
All disputes or differences whatsoever which may arise at any time during execution of the Contract shall be mutually settled by BHEL and supplier as per provision of the Contract. However, in the event such disputes cannot be settled mutually, such disputes shall be settled as per the Arbitration and reconciliation Act, 1996 of the Govt. of India and its subsequent amendments. In case of disputes with the Central PSUs, the same shall be settled at Tiruchirappalli as per the Guidelines of the Govt. of India. However, during the period such disputes are settled either by mutual discussions between the parties or by legal means, Supplier shall continue to do the work as per terms & conditions of Contract.
- 34. Suspension of business dealings**
Guidelines for suspension of business dealings with suppliers/contractors. Details available on BHEL website <http://www.bhel.com> at "supplier registration" tab
- 35. Fraud Prevention Policy**
“The bidder along with its associate/collaborators/sub-contractors /consultants/service providers shall strictly adhere to BHEL Fraud prevention policy displayed on BHEL website <http://www.bhel.com> and shall immediately bring to the notice of BHEL Management about fraud or suspected fraud as soon as it comes to their notice.
- 36. Cartel Formation:**
The Bidder declares that they will not enter into any illegal or undisclosed agreement or understanding, whether formal or informal with other Bidder(s). This applies in particular to prices, specifications, certifications, subsidiary contracts, submission or non-submission of bids or any other actions to restrict competitiveness or to introduce cartelization in the bidding process. In case, the Bidder is found having indulged in above activities, suitable action shall be taken by BHEL as per extant policies/ guidelines.

ANNEXURE –B **Enq.No.1902200001 dt: 28.01.22**
COMMERCIAL TERMS CONFIRMATION REQUIRED FROM THE SUPPLIERS
TO BE SUBMITTED ALONG WITH PART – I (TECHNO COMMERCIAL BID)

S. NO	DESCRIPTION	BHEL REQUIREMENTS	SUPPLIER CONFIRMATION
1.	Validity	120 days from the date of technical bid opening	
2.	Price quoted	For Destination / BHEL Stores / Trichy	
3.	GST details	CGST	%
		SGST	%
		IGST	%
4.	Delivery terms	F.O.R Destination (BHEL/Stores)	
5.	Delivery schedule	Single delivery date within 45 days from PO date.(non Deviatable)	
6.	Payment terms	100% direct payment after 45 days from the date of receipt and acceptance of materials at BHEL SSTP / TRICHY (S.No.13 of Annexure-A)	
7.	LD clause	0.5% per week to maximum of 10% (S.No.14 of Annexure-A)	
8.	Risk purchase clause	(For details please read S.No.15 of Annexure-A)	
9.	MSE details	Submission of Udyam Certificate (S.No.17 of Annexure-A)	
10.	Contact person details	NAME: MOBILE NO: EMAIL :	To be filled mandatorily
11.	Deceleration for Black-listed or not	Bidders have to confirm that, whether they have been black-listed / kept on hold / given Business holiday for a specified period by any Public Sector Undertaking or Government Departments/any other units of BHEL. (With reference to S.No.23 of Annexure – A).	
12.	Annexure-C	Duly filled & signed Integrity Pact (IP) should be furnished along with offer as per Annexure-C, IP should be signed by the authorized official of the bidder/Supplier/contractor. Offer received without signed IP will be rejected.	
13.	Annexure-D	Declaration for Preference to Make in India as per Annexure-D	
14.	Annexure I	Confirmation for PQC	
15.	Annexure-N	Applicable only for new supplier	

Note: Please fill-up all the column without fail

IMPORTANT NOTE:

Item wise confirmation of this format is essential to consider your offer.

*Sign and seal of the authorized
Person to sign the tender document*

INTEGRITY PACT

Between

Bharat Heavy Electricals Ltd. (BHEL), a company registered under the Companies Act 1956 and having its registered office at "BHEL House", Siri Fort, New Delhi - 110049 (India) hereinafter referred to as "The Principal", which expression unless repugnant to the context or meaning hereof shall include its successors or assigns of the ONE PART

and

_____, (description of the party along with address), hereinafter referred to as "The Bidder/ Contractor" which expression unless repugnant to the context or meaning hereof shall include its successors or assigns of the OTHER PART

Preamble

The Principal intends to award, under laid-down organizational procedures, contract/s for

_____. The Principal values full compliance with all relevant laws of the land, rules and regulations, and the principles of economic use of resources, and of fairness and transparency in its relations with its Bidder(s)/ Contractor(s).

In order to achieve these goals, the Principal will appoint Independent External Monitor(s), who will monitor the tender process and the execution of the contract for compliance with the principles mentioned above.

Section 1- Commitments of the Principal

- 1.1 The Principal commits itself to take all measures necessary to prevent corruption and to observe the following principles:-
 - 1.1.1 No employee of the Principal, personally or through family members, will in connection with the tender for, or the execution of a contract, demand, take a promise for or accept, for self or third person, any material or immaterial benefit which the person is not legally entitled to.
 - 1.1.2 The Principal will, during the tender process treat all Bidder(s) with equity and reason. The Principal will in particular, before and during the tender process, provide to all Bidder(s) the same information and will not provide to any Bidder(s) confidential/ additional information through which the Bidder(s) could obtain an advantage in relation to the tender process or the contract execution.
 - 1.1.3 The Principal will exclude from the process all known prejudiced persons.
- 1.2 If the Principal obtains information on the conduct of any of its employees which is a penal offence under the Indian Penal Code 1860 and Prevention of Corruption Act 1988 or any other statutory penal enactment, or if there be a substantive suspicion in this regard, the Principal will inform its Vigilance Office and in addition can initiate disciplinary actions:

Section 2 - Commitments of the Bidder(s)/ Contractor(s)

- 2.1 The Bidder(s)/ Contractor(s) commit himself to take all measures necessary to prevent corruption. He commits himself to observe the following principles during his participation in the tender process and during the contract execution.
- 2.1.1 The Bidder(s)/ Contractor(s) will not, directly or through any other person or firm, offer, promise or give to the Principal or to any of the Principal's employees involved in the tender process or the execution of the contract or to any third person any material, immaterial or any other benefit which he/ she is not legally entitled to, in order to obtain in exchange any advantage of any kind whatsoever during the tender process or during the execution of the contract.
- 2.1.2 The Bidder(s)/ Contractor(s) will not enter with other Bidder(s) into any illegal or undisclosed agreement or understanding, whether formal or informal. This applies in particular to prices, specifications, certifications, subsidiary contracts, submission or non-submission of bids or any other actions to restrict competitiveness or to introduce cartelization in the bidding process.
- 2.1.3 The Bidder(s)/ Contractor(s) will not commit any penal offence under the relevant Indian Penal Code (IPC) and Prevention of Corruption Act; further the Bidder(s)/ Contractor(s) will not use improperly, for purposes of competition or personal gain, or pass on to others, any information or document provided by the Principal as part of the business relationship, regarding plans, technical proposals and business details, including information contained or transmitted electronically.
- 2.1.4 Foreign Bidder(s)/ Contractor(s) shall disclose the name and address of agents and representatives in India and Indian Bidder(s)/ Contractor(s) to disclose their foreign principals or associates. The Bidder(s)/ Contractor(s) will, when presenting his bid, disclose any and all payments he has made, and is committed to or intends to make to agents, brokers or any other intermediaries in connection with the award of the contract.
- 2.2 The Bidder(s)/ Contractor(s) will not instigate third persons to commit offences outlined above or be an accessory to such offences.
- 2.3 The Bidder(s)/ Contractor(s) shall not approach the Courts while representing the matters to IEMs and will await their decision in the matter.

Section 3 - Disqualification from tender process and exclusion from future contracts

If the Bidder(s)/ Contractor(s), before award or during execution has committed a transgression through a violation of Section 2 above, or acts in any other manner such as to put his reliability or credibility in question, the Principal is entitled to disqualify the Bidder(s)/ Contractor(s) from the tender process or take action as per the separate "Guidelines on Banning of Business dealings with Suppliers/ Contractors", framed by the Principal.

Section 4 - Compensation for Damages

- 4.1 If the Principal has disqualified the Bidder from the tender process prior to the award according to Section 3, the Principal is entitled to demand and recover the damages equivalent Earnest Money Deposit/ Bid Security.
- 4.2 If the Principal has terminated the contract according to Section 3, or if the Principal is entitled to terminate the contract according to section 3, the Principal shall be entitled to

demand and recover from the Contractor liquidated damages equivalent to 5% of the contract value or the amount equivalent to Security Deposit/ Performance Bank Guarantee, whichever is higher.

Section 5 - Previous Transgression

- 5.1 The Bidder declares that no previous transgressions occurred in the last 3 years with any other company in any country conforming to the anti-corruption approach or with any other Public Sector Enterprise in India that could justify his exclusion from the tender process.
- 5.2 If the Bidder makes incorrect statement on this subject, he can be disqualified from the tender process or the contract, if already awarded, can be terminated for such reason.

Section 6 - Equal treatment of all Bidders/ Contractors / Sub-contractors

- 6.1 The Principal will enter into agreements with identical conditions as this one with all Bidders and Contractors. In case of sub-contracting, the Principal contractor shall be responsible for the adoption of IP by his sub-contractors and shall continue to remain responsible for any default by his sub-contractors.
- 6.2 The Principal will disqualify from the tender process all bidders who do not sign this pact or violate its provisions.

Section 7 - Criminal Charges against violating Bidders/ Contractors /Subcontractors

If the Principal obtains knowledge of conduct of a Bidder, Contractor or Subcontractor, or of an employee or a representative or an associate of a Bidder, Contractor or Subcontractor which constitutes corruption, or if the Principal has substantive suspicion in this regard, the Principal will inform the Vigilance Office.

Section 8 - Independent External Monitor(s)

- 8.1 The Principal appoints competent and credible Independent External Monitor for this Pact. The task of the Monitor is to review independently and objectively, whether and to what extent the parties comply with the obligations under this agreement.
- 8.2 The Monitor is not subject to instructions by the representatives of the parties and performs his functions neutrally and independently. He reports to the CMD, BHEL.
- 8.3 The Bidder(s)/ Contractor(s) accepts that the Monitor has the right to access without restriction to all contract documentation of the Principal including that provided by the Bidder(s)/ Contractor(s). The Bidder(s)/ Contractor(s) will grant the monitor, upon his request and demonstration of a valid interest, unrestricted and unconditional access to his contract documentation. The same is applicable to Sub-contractor(s). The Monitor is under contractual obligation to treat the information and documents of the Bidder(s)/ Contractor(s) / Sub-contractor(s) with confidentiality in line with Non- disclosure agreement.
- 8.4 The Principal will provide to the Monitor sufficient information about all meetings among the parties related to the contract provided such meetings could have an impact on the contractual relations between the Principal and the Contractor. The parties offer to the Monitor the option to participate in such meetings.

- 8.5 The role of IEMs is advisory, would not be legally binding and it is restricted to resolving issues raised by an intending bidder regarding any aspect of the tender which allegedly restricts competition or bias towards some bidders. At the same time, it must be understood that IEMs are not consultants to the Management. Their role is independent in nature and the advice once tendered would not be subject to review at the request of the organization.
- 8.6 For ensuring the desired transparency and objectivity in dealing with the complaints arising out of any tendering process, the matter should be examined by the full panel of IEMs jointly as far as possible, who would look into the records, conduct an investigation, and submit their joint recommendations to the Management.
- 8.7 The IEMs would examine all complaints received by them and give their recommendations/ views to CMD, BHEL, at the earliest. They may also send their report directly to the CVO and the Commission, in case of suspicion of serious irregularities requiring legal/ administrative action. IEMs will tender their advice on the complaints within 10 days as far as possible.
- 8.8 The CMD, BHEL shall decide the compensation to be paid to the Monitor and its terms and conditions.
- 8.9 IEM should examine the process integrity, they are not expected to concern themselves with fixing of responsibility of officers. Complaints alleging mala fide on the part of any officer of the organization should be looked into by the CVO of the concerned organisation.
- 8.10 If the Monitor has reported to the CMD, BHEL, a substantiated suspicion of an offence under relevant Indian Penal Code/ Prevention of Corruption Act, and the CMD, BHEL has not, within reasonable time, taken visible action to proceed against such offence or reported it to the Vigilance Office, the Monitor may also transmit this information directly to the Central Vigilance Commissioner, Government of India.
- 8.11 The number of Independent External Monitor(s) shall be decided by the CMD, BHEL.
- 8.12 The word 'Monitor' would include both singular and plural.

Section 9 - Pact Duration

- 9.1 This Pact shall be operative from the date IP is signed by both the parties till the final completion of contract for successful bidder and for all other bidders 6 months after the contract has been awarded. Issues like warranty / guarantee etc. should be outside the purview of IEMs.
- 9.2 If any claim is made/ lodged during currency of IP, the same shall be binding and continue to be valid despite the lapse of this pact as specified above, unless it is discharged/ determined by the CMD, BHEL.

Section 10 - Other Provisions

- 10.1 This agreement is subject to Indian Laws and jurisdiction shall be registered office of the Principal, i.e. New Delhi.

- 10.2 Changes and supplements as well as termination notices need to be made in writing. Side agreements have not been made.
- 10.3 If the Contractor is a partnership or a consortium, this agreement must be signed by all partners or consortium members.
- 10.4 Should one or several provisions of this agreement turn out to be invalid, the remainder of this agreement remains valid. In this case, the parties will strive to come to an agreement to their original intentions.
- 10.5 Only those bidders / contractors who have entered into this agreement with the Principal would be competent to participate in the bidding. In other words, entering into this agreement would be a preliminary qualification.

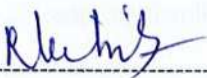

R. KILLIVALAVAN
 Senior Engineer
 PURCHASE / PSS / MM
 BHEL, TRICHY - 620 014

For & On behalf of the Principal

 For & On behalf of the Bidder/
 Contractor

(Office Seal)

(Office Seal)

Place TRICHY-14

Date 13-10-2021

Witness: 
 (Name & Address) Shano Thomas
MM/PSS, BHEL-TRICHY

Witness: _____
 (Name & Address) _____

Annexure - 2

INTEGRITY PACT: Signed Integrity pact (IP) should be furnished along with offer. IP would be signed by authorized official of the bidder/vendor/contractor. Offer without signed Integrity Pact (IP) shall be rejected. Copy of IP should be enclosed. This tender will be monitored by Independent external monitor (IEM). For information only.

IP is a tool to ensure that activities and transactions between the Company and its Bidders/ Contractors are handled in a fair, transparent and corruption free manner. Following Independent External Monitors (IEMs) on the present panel have been appointed by BHEL with the approval of CVC to oversee implementation of IP in BHEL.

Sl.No	IEM	Email
1	Shri Arun Chandra Verma, IPS (Retd.)	acverma1@gmail.com
2	Shri Virendra Bahadur Singh, IPS (Retd.)	vbsinghips@gmail.com

The IP as enclosed with the tender is to be submitted (duly signed by authorized signatory) along with techno-commercial bid (Part-I, in case of two/ three part bid). Only those bidders who have entered into such an IP with BHEL would be competent to participate in the bidding. In other words, entering into this Pact would be a preliminary qualification.

Please refer Section-8 of IP for Role and Responsibilities of IEMs. In case of any complaint arising out of the tendering process, the matter may be referred to any of the above IEM(s). All correspondence with the IEMs shall be done through email only.

Note:

No routine correspondence shall be addressed to the IEM (phone/ post/ email) regarding the clarifications, time extensions or any other administrative queries, etc on the tender issued. All such clarification/ issues shall be addressed directly to the tender issuing (procurement) department's officials whose contact details are provided below:

Details of contact person(s):		
Name	P L Pramila	R Killivalavan
Dept	SDGM/MM/SDC & PSS	Sr.Engr MM/Services
Address	Bldg No:24, BHEL Trichy	Bldg No:24, BHEL Trichy
Phone	0431 -2574737	0431 -2577104
E-Mail	pramila@bhel.in	kvalavan@bhel.in

/ On Bidder's office letter pad /

Self-Declaration

Enquiry No.	
Enquiry Date	

In line with Government public procurement order Number P-45021/2/2017-B.E-II dated 15.06.2017, and further modified order dt. 28.05.2018 & order 04.06.2020 issued by DPIIT

I / We hereby declare that I / We are a "Local Supplier" meeting the requirement of minimum local content (.....%) defined in the above government notification for the goods against above mentioned enquiry Number.

Details of location at which local value addition will be made is as follows:

Door No.	
Street / Address 1	
Street / Address 2	
District	
State	
Country	
PIN Code	

We also understand that the false declarations will be considered as breach of Integrity and liable for action.

For Company Name:

Seal:

Signature:

Date:

Place:

(Please fill all the yellow color field)

ANNEXURE - N

THE FOLLOWING DATA SHOULD BE FURNISHED BY NEW VENDOR

NAME & ADDRESS OF THE VENDOR		Document Submission
CONTACT / COMMUNICATION DETAILS	Name of dealing officials	YES / NO
	LANDLINE & MOBILE NO:	YES / NO
	EMAIL ID:	YES / NO
BUSINESS TYPE	MANUFACTURER / TRADER / AGENT	YES / NO
MSE STATUS	MSE / NON-MSE	YES / NO
MSE TYPE	MICRO / SMALL	YES / NO
TYPE OF MSE FIRM	PROPRIETARY / PARTNERSHIP	YES / NO
IN CASE OF PARTNERSHIP	PERCENTAGE OF SHARES	YES / NO
Partnership firm	Registered Partnership Deed duly signed by Registrar of Firms	YES / NO
Proprietorship	Profession Tax Regn./ Municipal Regn/ PAN of Firm (Proprietor)	
Private/Limited Company/One Person Company	Memorandum of Association, Articles of Association and Certificate of Incorporation	YES / NO
Co-operative society	Society rules & bye laws	YES / NO
State Govt. / Govt. Of India Undertaking	Memorandum & Articles of Association	YES / NO
COPY OF PAN CARD		YES / NO
GST REGISTRATION DOCUMENT		YES / NO
Professional Tax Regn/ Municipal Regn		YES / NO
Licence details of the factory		YES / NO
Manufacturing range & facilities: (If applicable)	<ul style="list-style-type: none"> • List down the product range & specification details. • List of Manufacturing facilities/equipment's (including material handling facility) 	YES / NO
If registered with any other BHEL unit	Letter of registration with BHEL unit (If applicable)	YES / NO
Accreditation certificate for ISO:9001 / TOC of Quality System manual / ISO:14000 / OHSAS ISO 18000	(If applicable)	

SIGN AND SEAL OF AUTHORIZED PERSON

FIRST ANGLE PROJECTION (ALL DIMENSIONS IN MILLIMETRES)

70/9E111-0000-11366

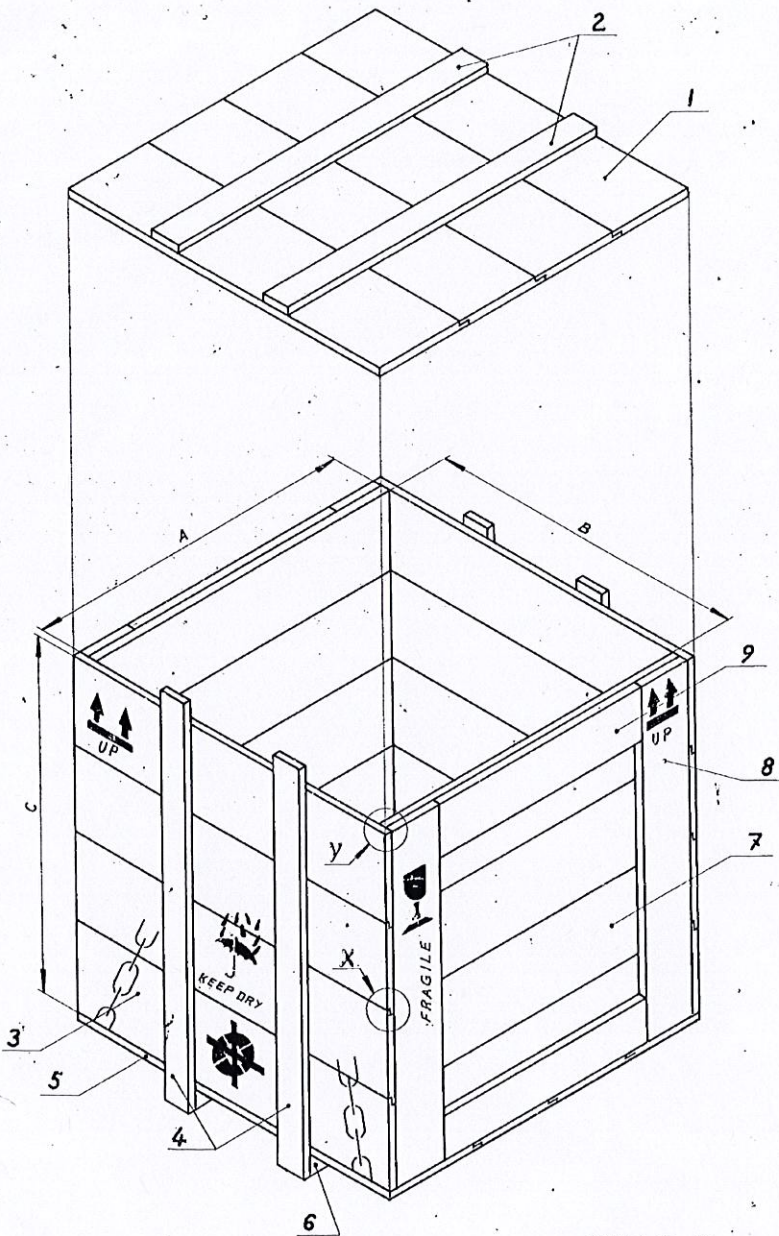

- 1. TOP BOARD - 25 THICK
- 2. TOP GIRTH BATTENS - 75 WIDTH X 40 THICK (EQUALLY SPACED)
- 3. SIDE BOARD - 25 THICK
- 4. SIDE GIRTH BATTENS - 75 WIDTH X 40 THICK
- 5. BOTTOM BOARD - 25 THICK
- 6. BOTTOM GIRTH BATTENS - 75 WIDTH X 25 THICK
- 7. END BOARD - 25 THICK
- 8. END VERTICAL BATTENS - 75 WIDTH X 40 THICK
- 9. END HORIZONTAL BATTENS - 75 WIDTH X 40 THICK

NOTE: THE NUMBER AND WIDTH OF THE SIDE AND END BOARDS SHALL BE DECIDED DEPENDING UPON THE HEIGHT (C).

DETAIL - X

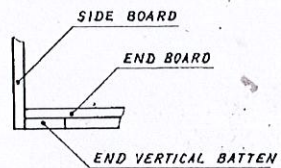

DETAIL - Y

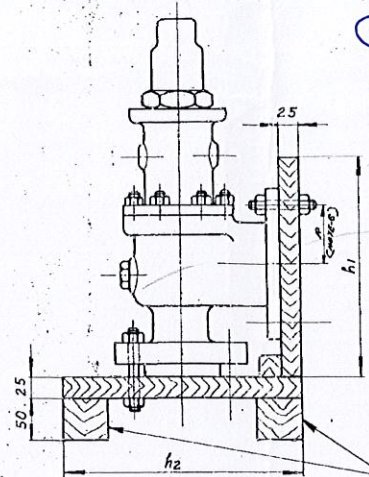
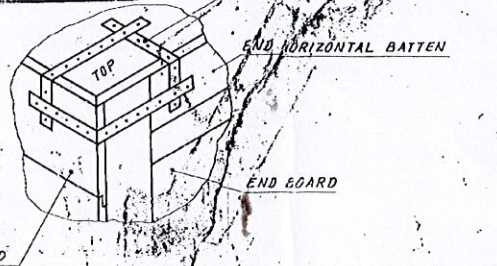

TYPE No.	DIMENSIONS			DRG. No.	QTY.	APPLICABLE TO VALVE TYPE NOS.		
	A	B	C					
1	250	250	800	200	240	240	1-V-9001-11136	1905 D, E, F, G - 1906 D, E, F, G - 1910 D, E - 1912 D, E. 1811 F, G, H, J ORIFICES 3X, 6X AND 8X VALVES
23	300	300	700	320	290	290	1-V-9005-11136	1905 H, J - 1906 H, J - 1910 F, G - 1912 F, G - 1914 D, E, F - 1916 D, E, F.
24	380	380	880	370	370	370	1-V-9007-11136	1905 K, L, M - 1906 K, L, M - 1910 H, J, K - 1912 H, J, K - 1914 H, J, K - 1916 G, H - 1918 D, E, F, G. 1811 K, L, M, N ORIFICES 3X, 6X AND 8X VALVES
4	475	475	1125	400	450	450	1-V-9010-11136	1905 N, P - 1906 N, P - 1910 L, M, N - 1912 L, M, N - 1914 K, L, M, N - 1916 J, K, L. 1811 P, Q ORIFICES 3X, 6X AND 8X VALVES
5	510	510	1400	460	500	500	1-V-9012-11136	1905 Q, R - 1906 Q, R - 1910 P, Q, R - 1912 P, Q, R - 1914 P, Q, R, 1767, 1738, 39, 47, 48, 49, 57, 58, 59, 65, 66, 75, 75R-4, 76, 76R-4 FLANGED VALVES
27	570	570	1400	530	560	560	1-V-9014-11136	1905 T - 1906 T - 1910 T - 1912 R, T.
7	250	250	880	350	240	240	1-V-7022-11136	1715, 16, 17, 25, 28 FLANGED VALVES
8	380	380	1125	450	370	370	1-V-7013-11136	1718, 19, 27, 28, 29, 35, 36, 37, 45, 46, 55, 56 FLANGED VALVES
28	575	575	1875	650	565	565	1-V-7038-11136	1775 Q-6, 76 Q-6, 77 Q-6, 85, 86, 85, 86, 85, 86, 87, 07 FLANGED VALVES

FOR WELDED INLET VALVES

10	510	510	1400	FOR CRADLE DIMENSIONS REFER DRG NOS. 3-V-2000-10448 & 3-V-2000-10449	1-V-2000-11136	1729 W, 40 W, 50 W, 77 W, 40 W, 55 W, 78 W, 58 W, 50 W.
11	575	575	1875	FOR CRADLE DIMENSIONS REFER DRG NOS. 3-V-2000-10448 & 3-V-2000-10449	1-V-2000-11136	1725 QW, 75 W, 85 W, 75 W-6, 85 W, 85 W, 76 W, 65 W.
12	380	380	1125	FOR CRADLE DIMENSIONS REFER DRG NOS. 3-V-2000-10448 & 3-V-2000-10449	1-V-2000-11136	1710 W, 18 W, 18 W, 20 W, 25 W, 26 W, 27 W, 28 W, 29 W, 35 W.
13	250	250	880	FOR CRADLE DIMENSIONS REFER DRG NOS. 3-V-2000-10448 & 3-V-2000-10449	1-V-2000-11136	1715 W, 16 W, 17 W.
61	575	575	1800	FOR CRADLE DIMENSIONS REFER DRG NOS. 3-V-2000-10448 & 3-V-2000-10449	1-V-2001-11136	1788 W, 17 W.

NOTES:

- THE INSIDE OF ALL SIDES EXCEPT BOTTOM AND TOP SIDES SHALL BE FULLY COVERED BY A SINGLE BITUMINISED PAPER AND SUITABLY FIXED. THE INSIDE OF TOP SIDE SHALL BE FIXED WITH BITUMINISED PAPER AND POLYETHYLENE SHEET. THE POLYETHYLENE SHEET SHALL BE PROTECTING 50mm ON ALL SIDES. AFTER PUTTING THE TOP FOR CLOSING THE CASE, THE PROJECTING POLYETHYLENE SHALL BE SUITABLY TACKED INSIDE SO AS TO PREVENT DIRECT ACCESS OF WATER FROM THE TOP OF THE CASE.
- THE VALVE ALONG WITH CRADLE ASSEMBLY SHALL BE COVERED BY A POLYETHYLENE SHEET AND THEN PLACED INSIDE THE BOX.
- PAINT MARKINGS AS SHOWN IN DRAWING ON ALL SIDES OF BOX.
- WOOD MATERIALS SHALL BE AS PER APPLICABLE STANDARD.
- CORNER STRAPPING SHALL BE USED ON ALL CORNERS. STRAPS SHALL NOT BE LESS THAN 20mm WIDE AND 0.8mm THICK. STRAPS MAY BE PRE PUNCHED OR DRILLED.
- THE RADIUS 'R' WILL VARY FROM VALVE TO VALVE DEPENDING UPON THE FLANGE OR BATTENS. THE PLANKS HAVE TO BE DRILLED SUITABLY DEPENDING UPON THE RANGE PCB AVAILABLE AND SUITABLE BOLTS AND NUTS ARE TO BE USED FOR FASTENING AS SHOWN.
- CRADLE ASBY. SHOULD BE AS PER DRG. No. 3-V-0000-1373A

Corrections done by me.
K. Rathnasekar

K. Rathnasekar
Senior Manager
MM/Stores/ INFL. & CNS
BHEL, Tiruchy - 14.

ENCLOSURE
SOSHO 247

04 4-976
NOTES UPDATED:
D.C.N. SR. 167

BHARAT HEAVY ELECTRICALS LIMITED
BOILER PLANT UNIT, TIRUCHIRAPALLI-620 014

PACKING BOX FOR SV & SRV

1.V.0000-11136 04

REV.	DATE	BY	CHKD.	REASON
01	3-6-83	CHD.	CHD.	INITIAL
02	10-8-83	CHD.	CHD.	TYPE NO. 16 ADDED

DRAWING
2-SH-CRT-00002
ON DRAWING

B 6. FOR DETAIL DRG. PL. REFER
TOP - 2-SH-B-001/B.
BOTTOM - 2-SH-B-001 A/B.
SIDE - 2-SH-B-001 B/B.
END - 2-SH-B-001 C/B.

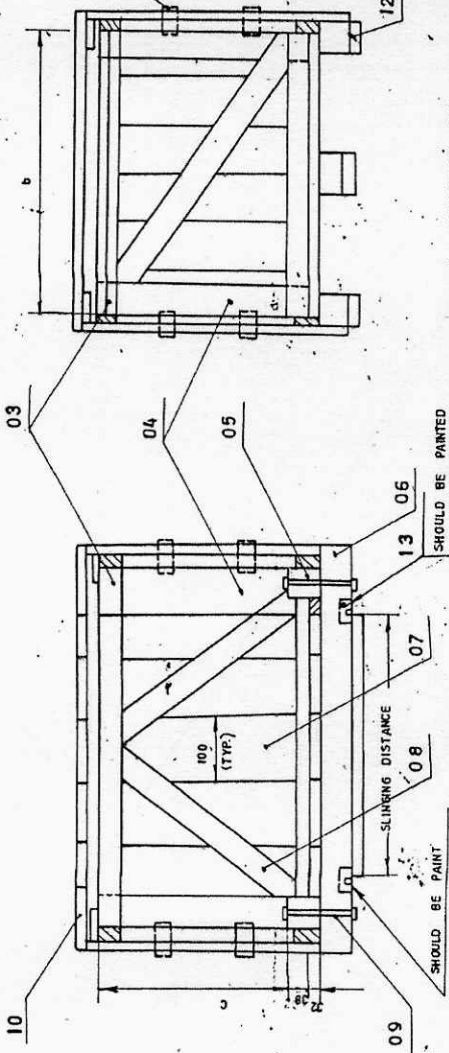

SECTION - XX

SECTION - YY

- NOTES:
1. END SHOOK IS TO BE FIXED WITH BASE 4 NAILS @ GAUGE.
 2. ALL OTHER NAILING SHOULD BE 2 1/2 - 10 GAUGE FOR ASSY.
 3. CORNER PLATE AND SLING PLATE IS TO BE FIXED WITH 2" NAILS 12 GAUGE.
 4. TYPE 966 BOX HAVE 2 RUNNERS IN THE BASE.

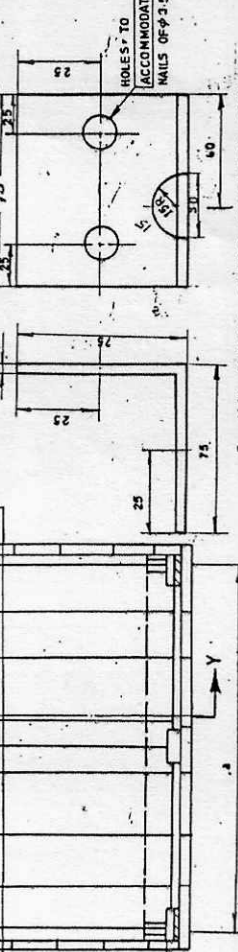

5. ALL SHOOKS SHOULD BE FIXED WITH POLYTHINE SHEET TO PROTECT FROM RAIN WATER.

TYPE	a	b	c
1577	1500	700	700
1399	1300	900	900
1296	1200	900	600
966	900	600	600

15	SLINGING DISTANCE SHOULD BE PAINTED	850
14	CAPACITY K.G	2000
13	SLING PL. 150 X 75 X 0.5MM SHOULD BE PAINTED	6 NOS
12	RESTING BOARD	40 X 100
11	SIDE PLATE SHOULD BE PAINTED X NAILS 2	F50 X 75 X 0.5
10	THICKNESS OF SHEATHING PLANK	150 X 25
09	BOLT SIZE	M 12 6 NOS
08	DIAGONAL BRACE	30 X 100
07	INTERMEDIATE VERTICAL SUPPORT	30 X 100
06	RUNNER	100 X 100 3 NOS
05	BASE END TRAVERSE BAR	70 X 70 2 NOS
04	LATERAL PANEL AND END PANEL VERTICAL SUPPORT	30 X 100
03	LATERAL PANEL AND END PANEL HORIZONTAL SUPPORT	30 X 100
01	TOP LONGITUDINAL BEAM	3 NOS. 30 X 100

TYPE OF PRODUCT
OR NAME OF ALL DIMENSIONS SHOWN FOR TV-1296 BOX
CUSTOMER'S/PRODUCT

SHARAT HEAVY ELECTRICALS LTD.
ONE, BANGALORE BOILER PLANT,
TUMAKURU-575001, KARNATAKA

DATE OF DRAWING: 15/05/2019
DRAWN BY: [Signature]
CHECKED BY: [Signature]
APPROVED BY: [Signature]

SCALE: 1:1

WEIGHT (KG):

DRIVING NO. 2-SH-CRT-00002

CARD CODE U 01

Size A2

FOR TOLERANCES OF UNTOLERANCED DIMENSIONS DURING MANUFACTURE REFER RELEVANT SPECIFICATION

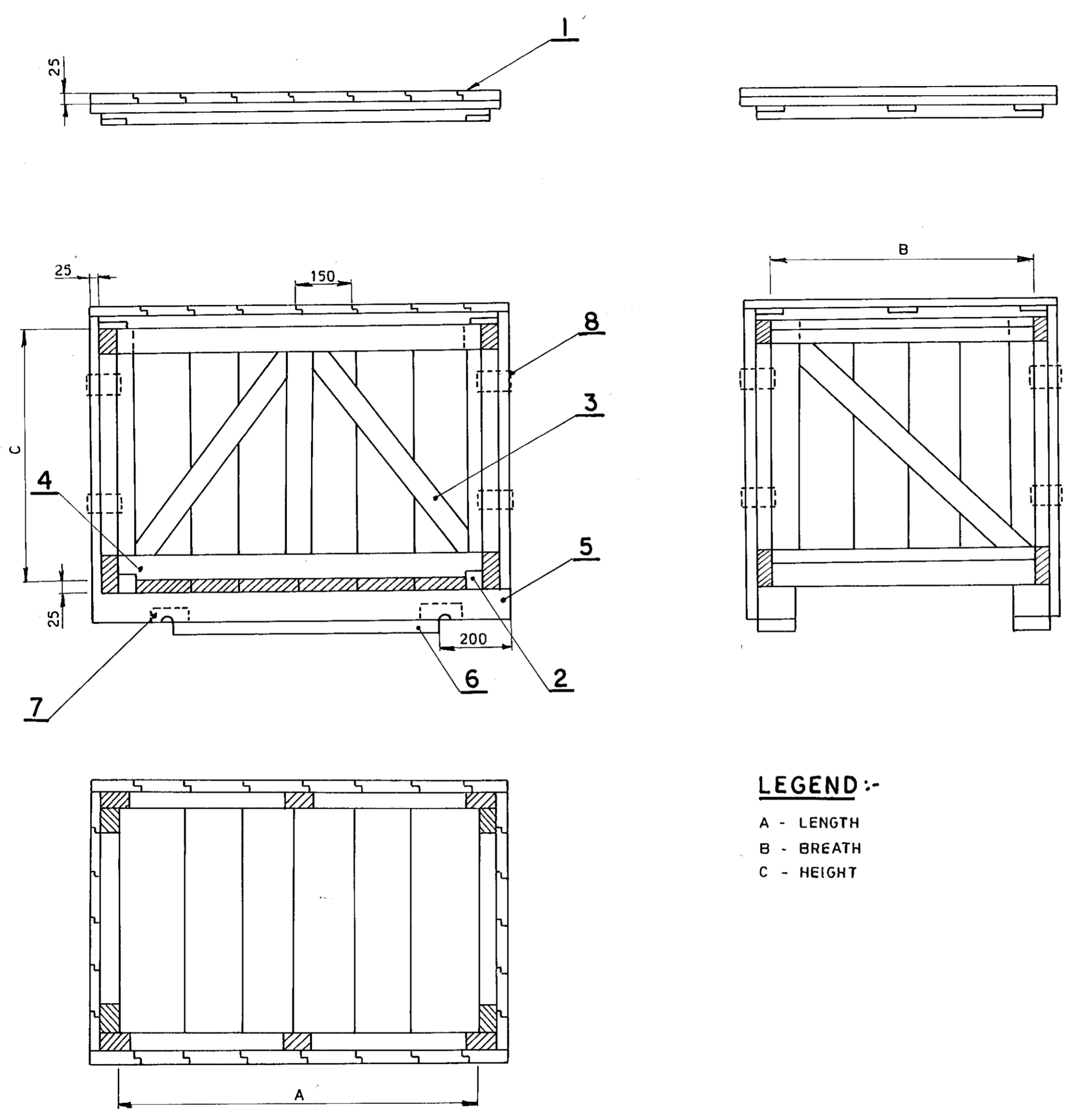

LEGEND :-
A - LENGTH
B - BREADTH
C - HEIGHT

SL NO.	DRG. NO.	TYPE	DIMENSIONS			MATL-CODE
			A	B	C	
1	2-V-0001-05779	3	670	670	470	20 015 030
2	2-V-0002-05779	4	710	630	600	20 015 080
3	2-V-0003-05779	5	850	630	670	20 015 081
4	2-V-0004-05779	6	1000	770	670	20 015 082
5	2-V-0005-05779	7	1100	430	670	—
6	2-V-0006-05779	9	1250	570	1100	20 015 083
7	2-V-0007-05779	10	1300	770	1050	20 015 084
8	2-V-0008-05779	13	1700	600	700	20 015 086
9	2-V-0009-05779	14	1850	1050	1250	20 015 095
10	2-V-0010-05779	15	2000	800	800	20 015 088
11	2-V-0011-05779	5A	900	450	950	20015210

ITEM No	DESCRIPTION	SIZE (MM)	MATERIAL
1	SOFT WOOD PLANKS	25 X 150	WOOD
2	END TRAVERS BAR	50 X 50	WOOD
3	DIAGONAL BRACE	75 X 25	WOOD
4	SOFT WOOD BATTERNS	75 X 25	WOOD
*5	RUNNERS	70 X 70 (FOR TYPE 3, 4, 5, 5A, 6, 7, 9, 13) 100 X 100 (FOR TYPE 10, 14, 15)	WOOD
6	RESTING BEAM	150 X 75 X 50	WOOD
7	SLING PLATE	—	M.S. SHEET
8	SIDE PLATE	—	M.S. SHEET

NOTES FOR PACKING:

- 1. THE INSIDE OF ALL SIDES EXCEPT BOTTOM SHALL BE FULLY COVERED BY POLYETHYLENE SHEET SO AS TO AVOID ENTRY OF RAIN WATER.
- 2. SECURE THE ASSEMBLIES WITH ENOUGH SIDE SUPPORTS TO AVOID MOVEMENT OF ASSEMBLIES DURING TRANSIT.

* 2 NOS TO BE PROVIDED

REV	DATE	ALTD:	REV.	DATE	ALTD:-	REV	DATE	ALTERED P.R.K.
0		CHD-8	02	16.5.96	CHD&APPD: <i>Janu</i>	01	01.12.95	CHECKED SCS <i>mt</i>
					DIMNS. IN SL.No. 11 900, 450 & 950 WERE 800, 400 & 900 RESPECTIVELY			RUNNER SIZE CHANGED. FOR TYPE NO: 1014 & 15 REQUEST FROM SHIPPING.

NO. OF PIECES	DESCRIPTION	SEM. PRO/SEQ NO	INT. MAT/ SEQ.NO.	FINAL MATERIAL	SCRAP SORT	NET WT(KG)	GROSS WT(KG)	DRAWING NO.	ITEM NO.
<p>BHARAT HEAVY ELECTRICALS LTD., BOILER PLANT UNIT, TIRUCHIRAPALLI-14</p>									
FIRST ANGLE		SCALE		DRAWN		TOTAL NET WT.(KG)		REVISION	
		NTS		E.C.D.I.D.				02	
				CHECKED		TYPE			
				APPROVED					
ALL DIMENSIONS IN MILLIMETRES				DATE		NEW / OLD DRG. NO.		2-SH-BW-0226	
<p>CAUTION</p> <p>THE INFORMATION CONTAINED IN THIS DRAWING IS THE PROPERTY OF BHARAT HEAVY ELECTRICALS LTD., BOILER PLANT UNIT, TIRUCHY-14 AND SHALL NOT BE USED WITHOUT THEIR EXPRESS WRITTEN PERMISSION IN ANY FORM OR PART THEREOF FOR ANY OTHER PURPOSE THAN FOR WHICH IT IS SENT TO YOU.</p>									
<p>PACKING BOX (VALVES)</p>								DRAWING NO.	
<p>33-114</p>								2-V-0000-05779	

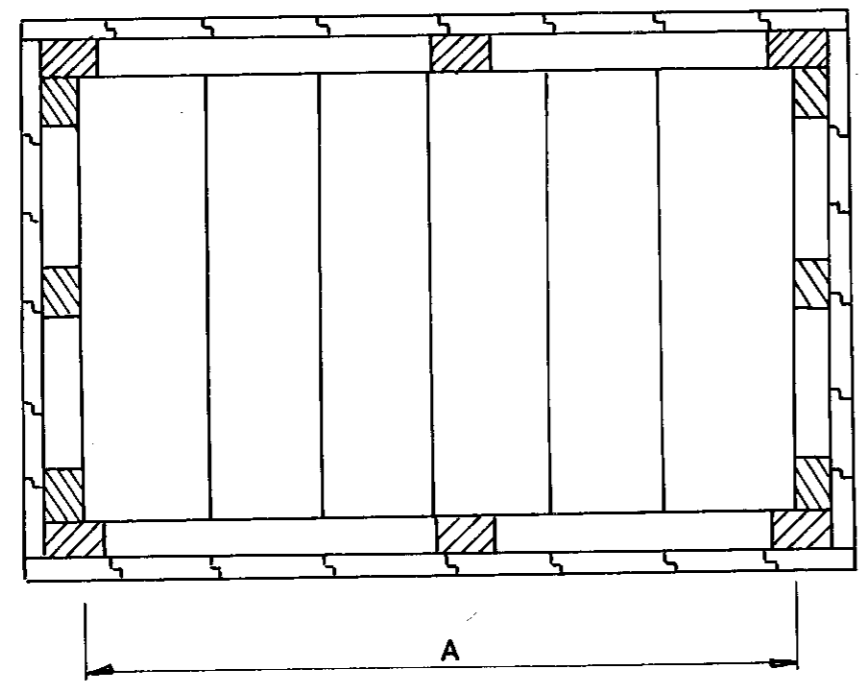
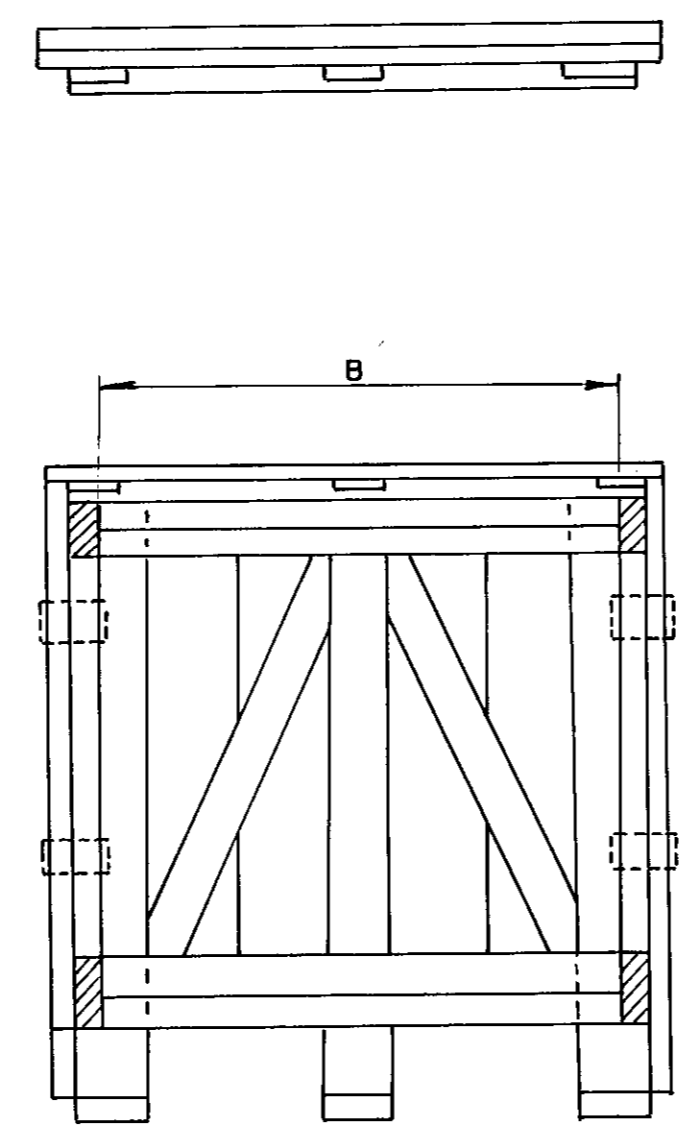
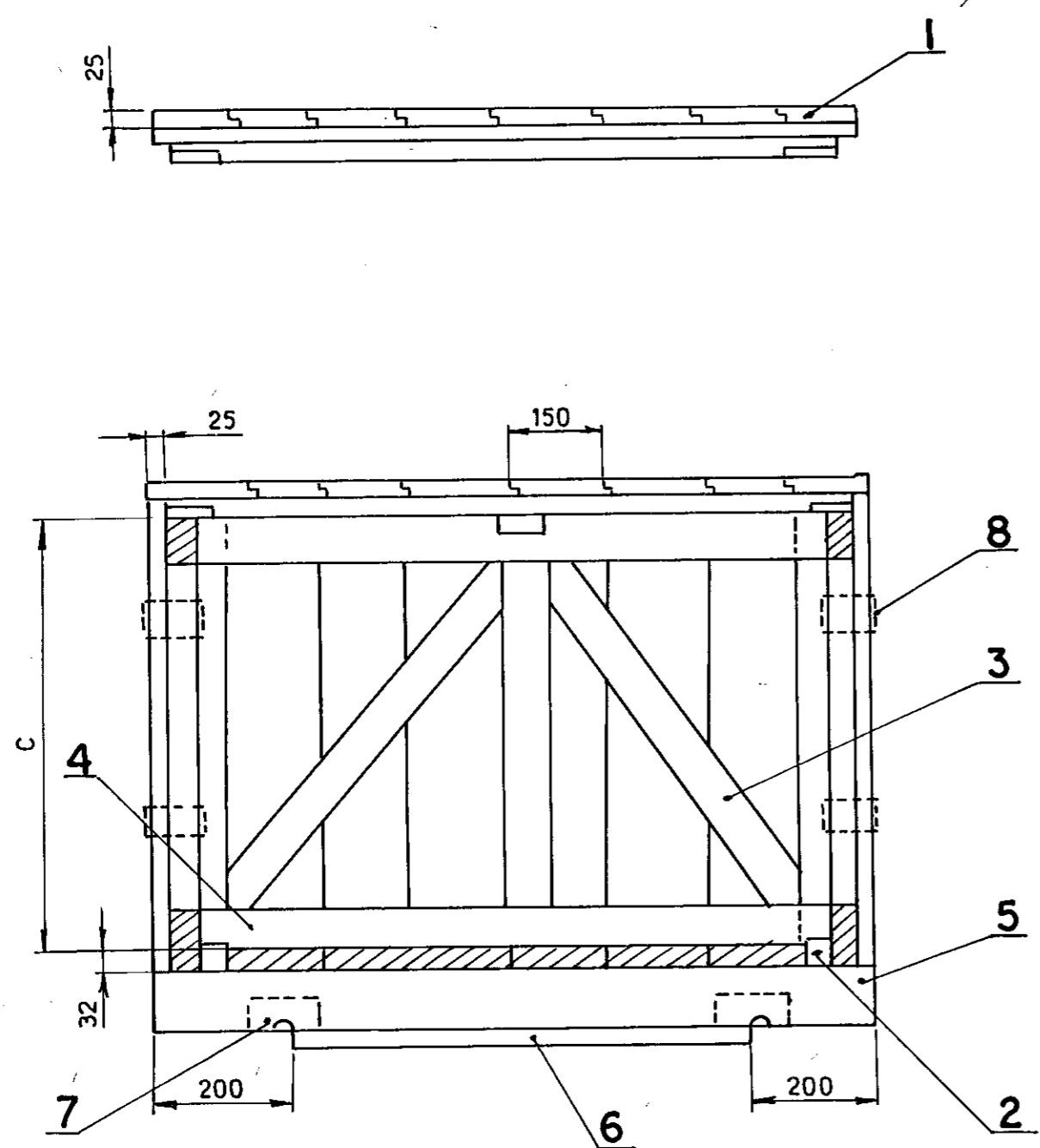

LEGEND

- A = LENGTH
- B = BREATH
- C = HEIGHT



SL NO	DRG. NO.	TYPE	DIMENSIONS			MATL - CODE
			A	B	C	
1	2-V-0001-05780	8	1200	1200	900	20 015 092
2	2-V-0002-05780	11	2500	850	800	20 015 093
3	2-V-0003-05780	12	2000	1500	1200	20 015 094
4	2-V-0004-05780	16	3000	1000	1000	20 015 096
5	2-V-0005-05780	17	2600	1500	1600	20 015 097
6	2-V-0006-05780	29	3600	1100	1100	20 015 102

NOTES FOR PACKING:-

1. THE INSIDE OF ALL SIDES EXCEPT BOTTOM SHALL BE FULLY COVERED BY POLYETHYLENE SHEET SO AS TO AVOID ENTRY OF RAIN WATER.
2. SECURE THE ASSEMBLIES WITH ENOUGH SIDE SUPPORTS TO AVOID MOVEMENT OF ASSEMBLIES DURING TRANSIT.

ITEM No	DESCRIPTION	SIZE (MM)	MATERIAL
1	SOFT WOOD PLANKS	25 X 150	WOOD
2	END TRAVERS BAR	50 X 50	WOOD
3	DIAGONAL BRACE	75 X 25	WOOD
4	SOFT WOOD BATTERNS	75 X 25	WOOD
* 5	RUNNERS	100 X 100	WOOD
6	RESTING BEAM	150 X 75 X 50 (FOR TYPE 8, 11 & 12) 100 X 50 (FOR TYPE 16, 17 & 29)	WOOD
7	SLING PLATE	-	M.S. SHEET
8	SIDE PLATE	-	M.S. SHEET

* 3 NOS TO BE PROVIDED

NO. OF PIECES	DESCRIPTION	SEM. PRO/SEQ. NO.	INT. MAT/SEQ. NO.	FINAL MATERIAL	SCRAP SORT	NET WT.(KG)	GROSS WT.(KG)	DRAWING NO.	ITEM NO.	
 BHARAT HEAVY ELECTRICALS LTD., BOILER PLANT UNIT, TIRUCHIRAPALLI-14										
FIRST ANGLE	SCALE	DRAWN	ECD/D	TOTAL NET WT.(KG)						
	NTS	CHECKED	R.L. [Signature]	TYPE						
ALL DIMENSIONS IN MILLIMETRES		APPROVED	M.R.K. [Signature]	DATE	14/12/24	NEW / OLD DRG. NO.	2-SH.BW.023			
CAUTION				TITLE						
THE INFORMATION CONTAINED IN THIS DRAWING IS THE PROPERTY OF BHARAT HEAVY ELECTRICALS LTD., BOILER PLANT UNIT, TIRUCHY-14 AND SHALL NOT BE USED WITHOUT THEIR EXPRESS WRITTEN PERMISSION IN ANY FORM OR PART THEREOF FOR ANY OTHER PURPOSE THAN FOR WHICH IT IS SENT TO YOU.				PACKING BOX (VALVES)						
 33-114				DRAWING NO.		2 - V - 0000 - 05780		REVISION		0

A	DATE	ALTERED
ZONE		CHECKED

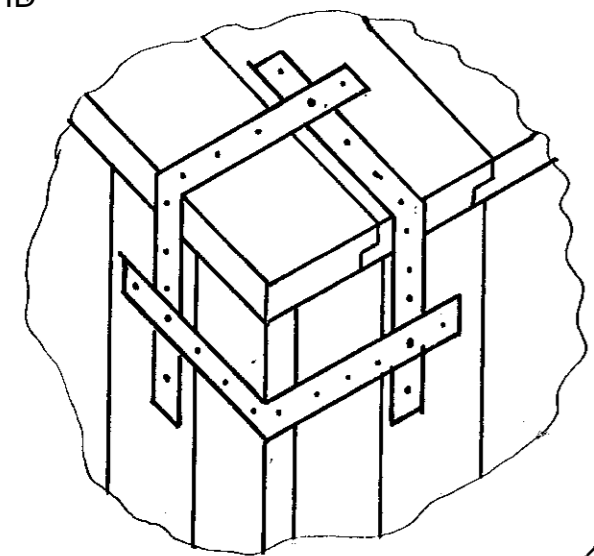

CORNER STRAPPING
(SEE NOTE-3)

301	BOX TYPE NO: 56	3000	1000	900	20015109 0000	1300 KG
302	BOX TYPE NO: 57	3200	2200	950	20015110 0000	1250 KG
303	BOX TYPE NO: 58	2200	1100	750	20015111 0000	800 KG
305	BOX TYPE NO: 59	2900	1950	850	20015116 0000	
306	BOX TYPE NO: 60	2300	2200	1200	20015115 0000	

ITEM No	TYPE	DIMENSIONS			COMP. CODE	APROX. LOAD TO BE CARRIED
		L	W	H		
296	BOX TYPE NO: 51	2775	850	680	20015098 0000	850 KG
297	BOX TYPE NO: 52	2000	950	740	20015100 0000	1000 KG
298	BOX TYPE NO: 53	1600	1120	700	20015101 0000	650 KG
299	BOX TYPE NO: 54	2500	2000	1200	20015106 0000	2000 KG
300	BOX TYPE NO: 55	2900	1900	1400	20015107 0000	2000 KG

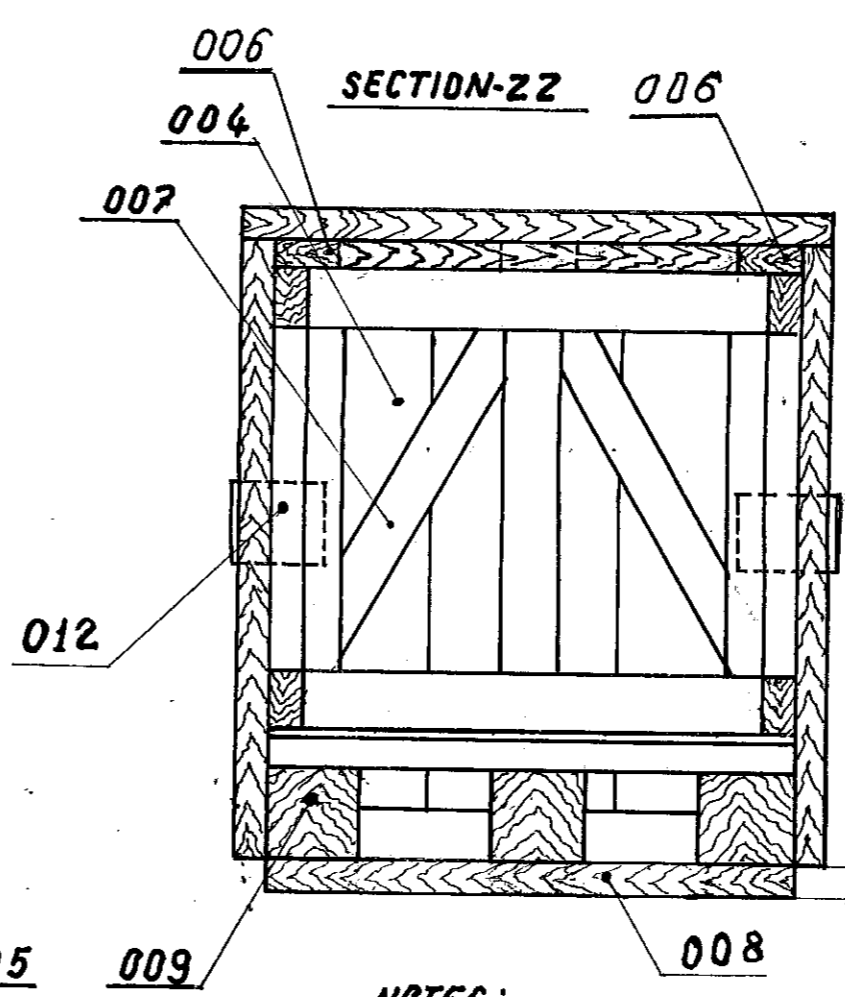
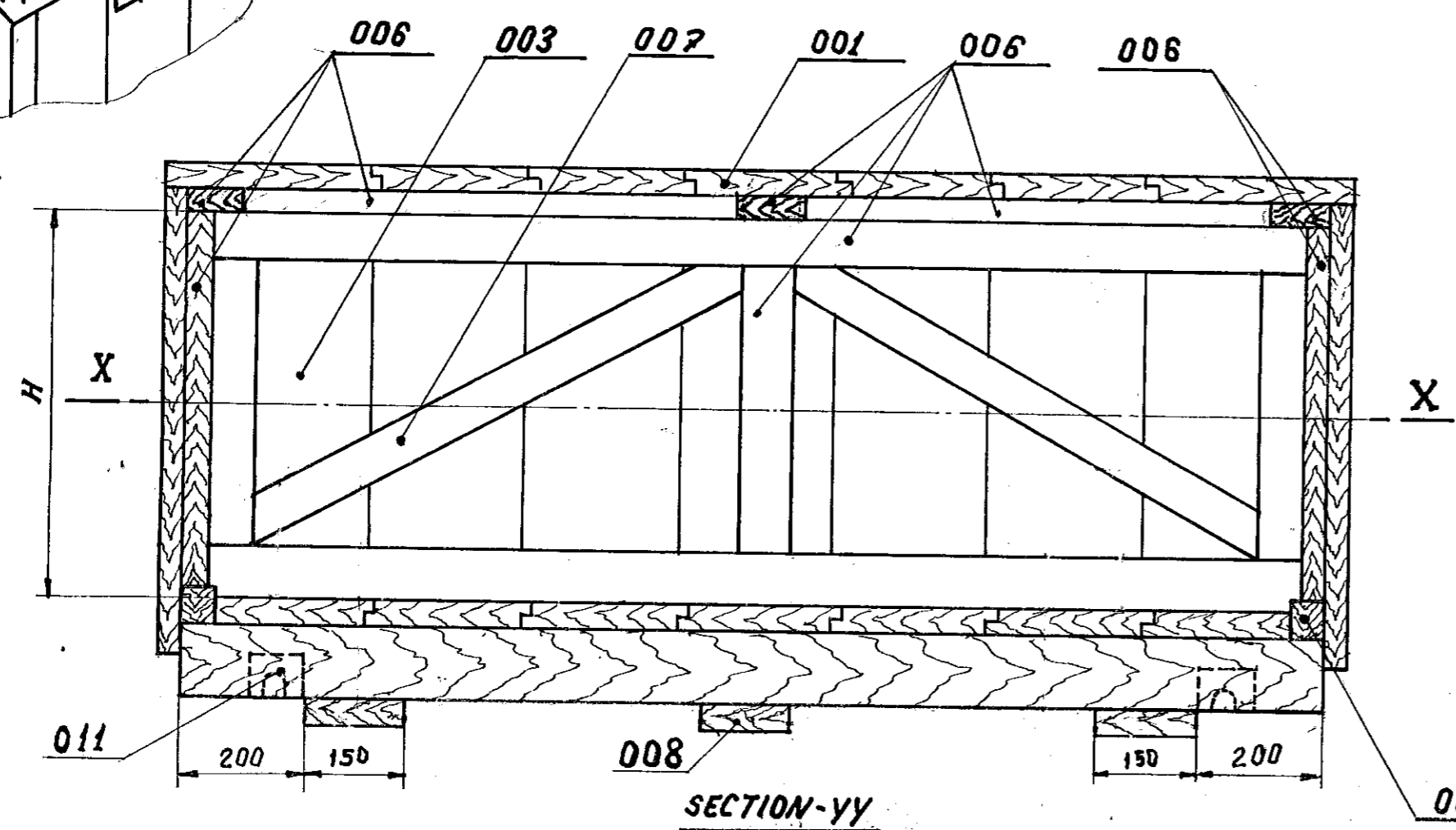

- 001 TOP BOARD : 25 MM THICK.
- 002 BOTTOM BOARD : 25 MM THICK.
- 003 SIDE BOARD : 25 MM THICK.
- 004 END BOARD : 25 MM THICK.
- 005 END TRAVERSE BAR : 75 X 50
- 006 ALL SIDE GRITH BATTENS : 100X25
- 007 ALL DIAGONAL BRACES : 100 X 25
- 008 RESTING BEAMS : 150 X 50
- 009 RUNNERS : ~~150 X 100~~ 100 X 100
- 010 SUPPORTS : ~~150 X 225~~
- 011 SLING PLATE (MS SHEET)
- 012 SIDE PLATE (MS SHEET)
- * ALL WOODS SHOULD BE OF QUALITY WOOD.

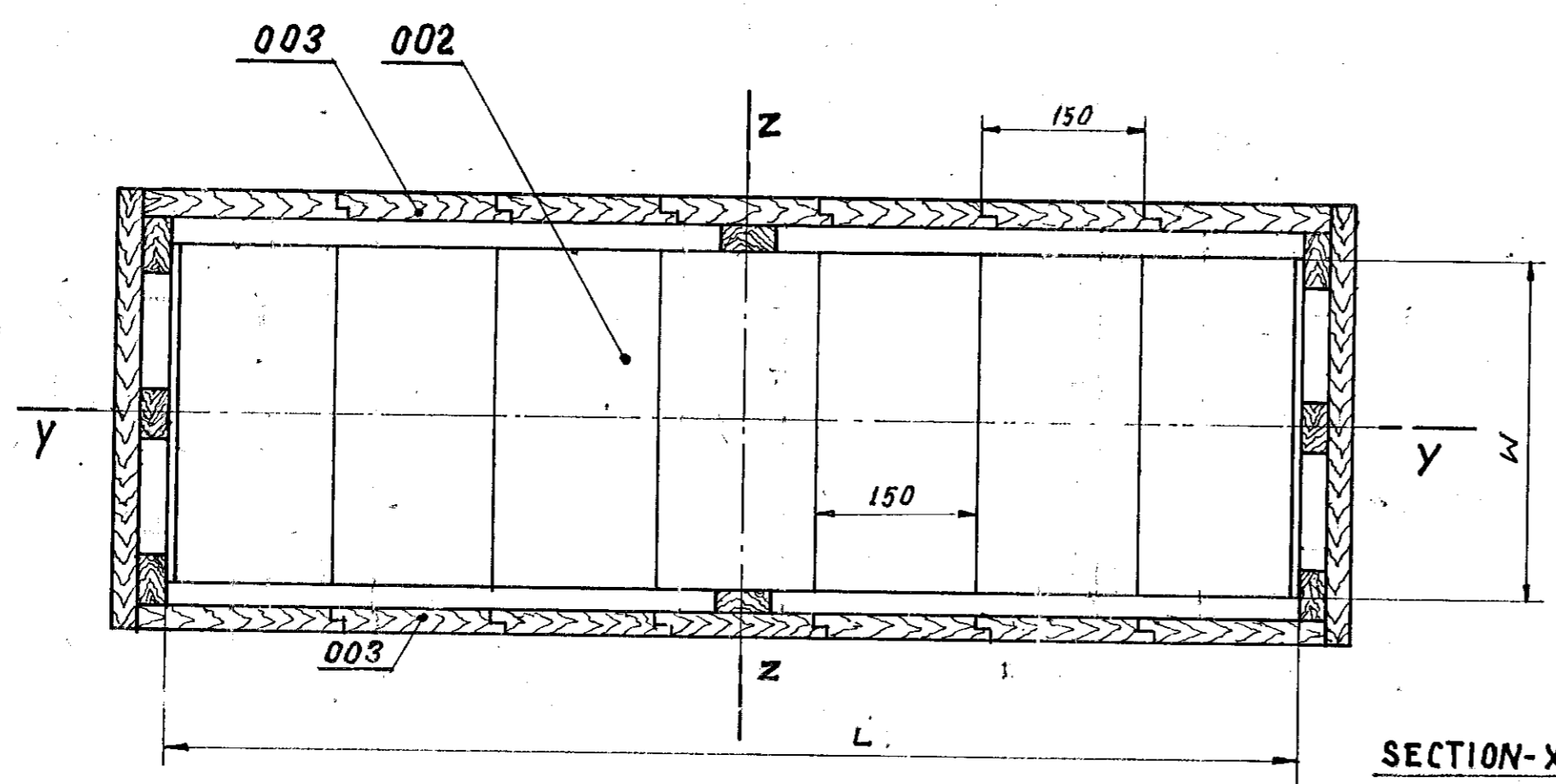

NOTES:-

1. THE INSIDE OF ALL SIDES EXCEPT BOTTOM AND TOP SIDE SHALL BE FULLY COVERED BY A SINGLE BITUMINISED PAPER AND SUITABLY FIXED. THE INSIDE OF TOP SIDE SHALL BE FIXED WITH BITUMINISED PAPER AND POLYETHYLENE SHEET. THE POLYETHYLENE SHEET SHALL BE PROJECTING 50 MM ON ALL SIDES. AFTER PUTTING THE TOP FOR CLOSING THE CASE, THE PROJECTING POLYETHYLENE SHALL BE SUITABLY TACKED INSIDE SO AS TO PREVENT DIRECT ACCESS OF WATER FROM THE TOP OF THE CASE.
2. TO INDICATE TOP SIDE OF BOX PAINT SUITABLY BY MARKING. (PREFERABLY BY UMBRELLA MARKING (6"X6") ON ALL 4 SIDES OF THE BOX.
3. CORNER STRAPPING SHALL BE USED ON ALL CORNERS. STRAPS SHALL NOT BE LESS THAN 20 MM WIDE AND 0.8 MM THICK. STRAPS MAY BE PRE PUNCHED OR DRILLED.
4. THE NUMBER AND WIDTH OF THE SIDE AND END BOARDS SHALL BE DECIDED DEPENDING UPON THE HEIGHTS.
5. COMPONENTS LIKE SLIP, TUBING HANGER, FASTENERS, RJ GASKETS, PR. GAUGES ETC. ARE TO BE PACKED SEPARATELY IN A BOX AND PLACED INSIDE THE MAIN BOX.
6. SECURE THE ASSEMBLIES WITH ENOUGH SIDE SUPPORTS TO AVOID MOVEMENTS OF ASSEMBLIES DURING TRANSIT AND ALSO SECURE SUITABLY TO AVOID VERTICAL MOVEMENT.

MF 1097082

REV	DATE	ALTD	CHD	REV	DATE	ALTD	CHD
01	28.4.86	K. Sankar	K. Namalingam	03	26.11.87	K. Sankar	K. Namalingam
02	12.9.87	K. Sankar	K. Namalingam	04	8.2.88	K. Sankar	K. Namalingam
03	07.08.88	K. Sankar	K. Namalingam	05	4.8.88	K. Sankar	K. Namalingam
04	07.20.12	K. Sankar	K. Namalingam	06	07.08.88	K. Sankar	K. Namalingam

BHARAT HEAVY ELECTRICALS LTD.,
BOILER PLANT UNIT, TIRUCHIRAPALLI-14

REV 01 DATE 28.4.86 ALTD: K. Sankar CHD: K. Namalingam

REV 02 DATE 12.9.87 ALTD: K. Sankar CHD: K. Namalingam

REV 03 DATE 07.08.88 ALTD: K. Sankar CHD: K. Namalingam

REV 04 DATE 07.20.12 ALTD: K. Sankar CHD: K. Namalingam

REV 05 DATE 07.08.88 ALTD: K. Sankar CHD: K. Namalingam

REV 06 DATE 07.08.88 ALTD: K. Sankar CHD: K. Namalingam

001 TOP BOARD DIMN. 25 MM WAS 50

002 BOTTOM BOARD 25 MM WAS 50

003 SIDE BOARD 25 MM WAS 50

004 END BOARD 25 MM WAS 50

005 END TRAVERSE BAR 75X50 WAS 100X50

010 SUPPORTS REMOVED.

009 RUNNERS 150 X 100 WAS 150 X 150

001 GRITH BATTENS ADDED AT THE CENTRES OF THE TOP BOARD.

002 BOX TYPE NO. 59 ADDED.

003 BOX TYPE NO. 56, 57 & 58 ADDED.

004 GRITH BATTENS ADDED AT THE CENTRES OF THE TOP BOARD.

005 BOX TYPE NO. 54 & 55 ADDED.

006 BOX TYPE NO. 60 ADDED.

007 BOX TYPE NO. 59 ADDED.

008 BOX TYPE NO. 59 ADDED.

009 BOX TYPE NO. 59 ADDED.

010 BOX TYPE NO. 59 ADDED.

011 BOX TYPE NO. 59 ADDED.

012 BOX TYPE NO. 59 ADDED.

CAUTION: THE INFORMATION CONTAINED IN THIS DRAWING IS THE PROPERTY OF BHARAT HEAVY ELECTRICALS LTD., BOILER PLANT UNIT, TIRUCHY-14 AND SHALL NOT BE USED WITHOUT THEIR EXPRESS WRITTEN PERMISSION IN ANY FORM OR PART THEREOF FOR ANY OTHER PURPOSE THAN FOR WHICH IT IS SENT TO YOU.

TITLE: FOR OIL FIELD EQUIPMENTS
PACKING BOX

DRAWING NO. 2-V-4600-03636

REVISION 08

FIRST ANGLE PROJECTION (ALL DIMENSIONS IN MILLIMETRES)

2-V-7503-10122

DRAWING No.

CAUTION: THE INFORMATION ON THIS DOCUMENT IS THE PROPERTY OF BHARAT HEAVY ELECTRICALS LTD. IT IS TO BE USED DIRECTLY OR INDIRECTLY IN ANY WAY DETRIMENTAL TO THE INTERESTS OF THE COMPANY.

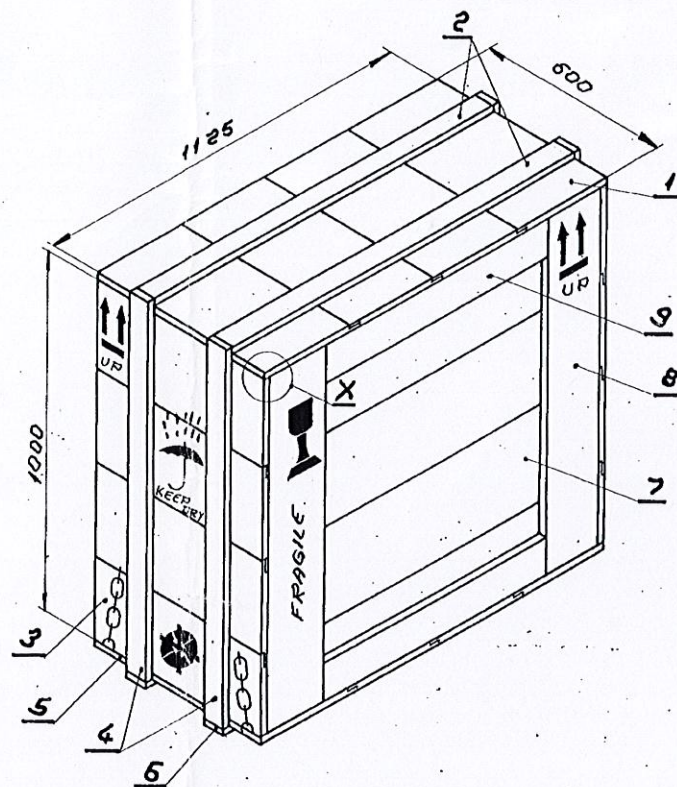
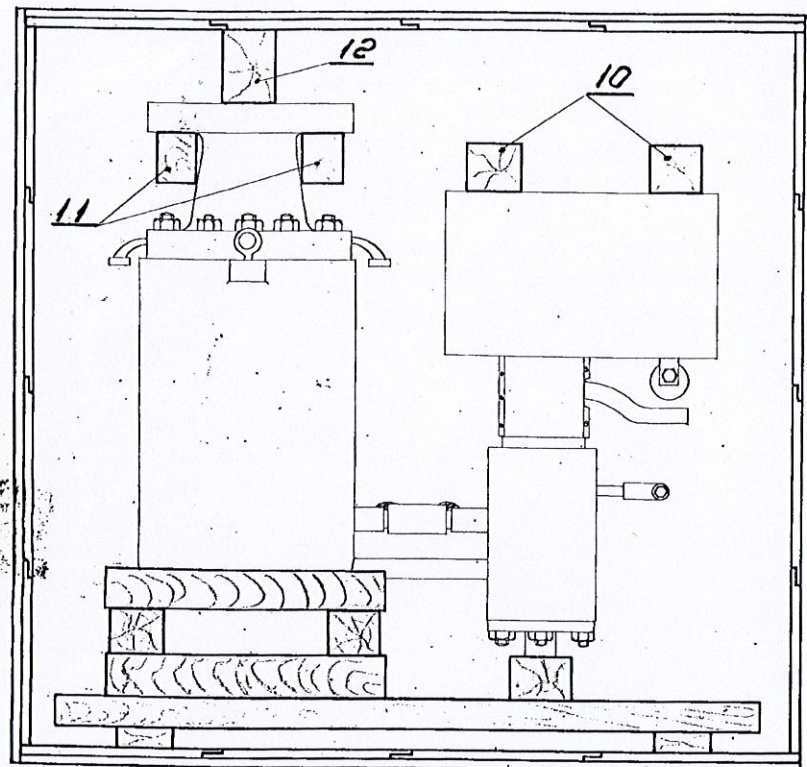

NOTES:-

1. THE INSIDE OF ALL SIDES EXCEPT BOTTOM & TOP SIDE SHALL BE FULLY COVERED BY A SINGLE BITUMINISED PAPER AND SUITABLY FIXED. THE INSIDE OF TOP SIDE SHALL BE FIXED WITH BITUMINISED PAPER AND POLY ETHYLENE SHEET. THE POLY ETHYLENE SHEET SHALL BE PROJECTING 50mm ON ALL SIDES. AFTER PUTTING THE TOP FOR CLOSING THE CASE, THE PROJECTING POLY ETHYLENE SHALL BE SUITABLY TACKED INSIDE SO AS TO PREVENT DIRECT ACCESS OF WATER FROM THE TOP OF THE CASE.
2. THE VALVE ALONG WITH CRADLE ASSEMBLY SHALL BE COVERED BY A POLYETHYLENE SHEET AND THEN PLACED INSIDE THE BOX.
3. PAINT MARKINGS AS SHOWN IN DRG ON ALL SIDES OF BOX.
4. WOOD MATERIALS SHALL BE AS PER BIS-015501 OR IS-1503-1967
5. CORNER STRAPPING SHALL BE USED ON ALL CORNERS. STRAPS SHALL NOT BE LESS THAN 20 mm WIDE AND 0.8 mm THICK. STRAPS MAY BE PRE BUNCHED OR DRILLED.

1. TOP BOARD - 25 THICK
2. TOP GIRTH BATTENS - 75 WIDTH X 40 THICK (EQUALLY SPACED)
3. SIDE BOARD - 25 THICK
4. SIDE GIRTH BATTENS - 75 WIDTH X 40 THICK
5. BOTTOM BOARD - 25 THICK
6. BOTTOM GIRTH BATTENS - 75 WIDTH X 75 THICK
7. END BOARD - 25 THICK
8. END VERTICAL BATTENS - 75 WIDTH X 40 THICK
9. END HORIZONTAL BATTENS - 75 WIDTH X 40 THICK
10. PLANK SIZE 75 X 75 X 470
11. PLANK SIZE 50 X 75 X 470
12. PLANK SIZE 70 X 120 X 470

NOTE: THE NUMBER AND WIDTH OF THE SIDE & END BOARDS BE DECIDED DEPENDING UPON THE HEIGHT.

This drawing is pertaining to TYPE 62 BOX

K. Rathnasekar
 K. Rathnasekar
 Senior Manager
 MM/Stores/ INPL. & CNS
 BHEL, Tiruchy - 14.

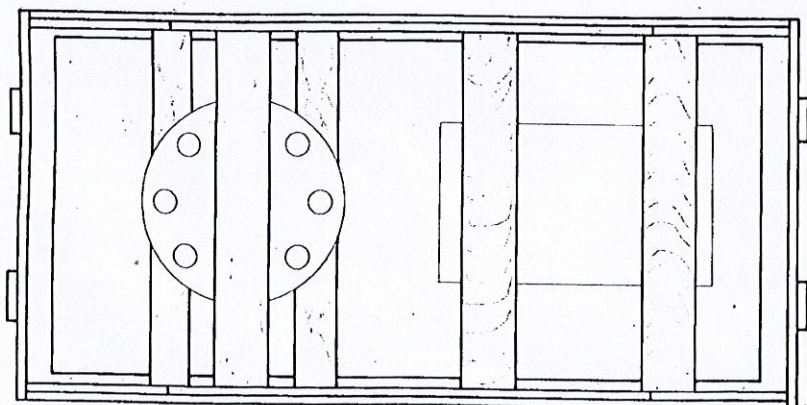

CORNER STRAPPING (NOTE-5)

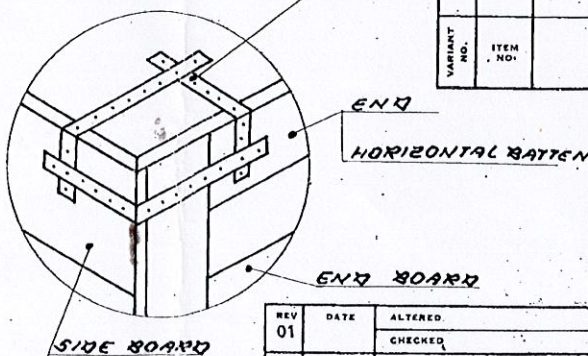

DETAIL - X

VARIATION NO.	ITEM NO.	DESCRIPTION	STD.	DRAWING NO.	ITEM NO.	MATL CODE	A	UNIT	UNIT WT	QTY
					VAR NO.	MATL SPEC	C			

MICROFILMED ON
 ROLL (SEE) FRAME 404

Bharat Heavy Electricals Ltd.,
 BOILER PLANT UNIT
 TIRUCHIRAPALLI-620 014

DRN: K. P. LEON
 CHD: V. PERUMAL
 APPD: J. ARUNAN

DEPT: GRADE OF UNTOOL. DIM C/M/F
 SCALE:

WEIGHT (kg):

TITLE: **PACKING BOX FOR ERV**
 1538 Vx

CARD CODE: U 01
 DRAWING NO.: 2-V-7503-10122

PACKING CRADLE DRG No
 3-V-7503-10463

CORPORATE DRG ID: TP-DG-2V-7503-10122

CORPORATE DRG ID: TP-DG-2V-7503-10122

B/400 - B - HS - E

02 100MM X 30MM

01 150MM X 25MM

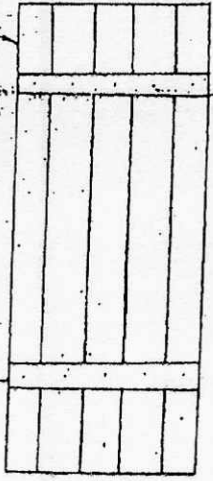

TOP & BASE
(2 NOS.)

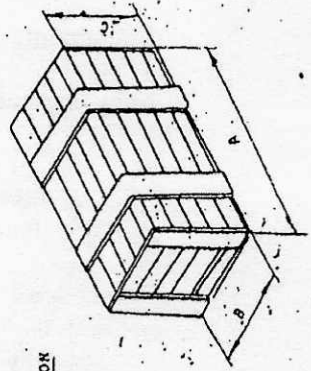

DETAILS OF ALL SIDES PROTECTION
INTERNAL

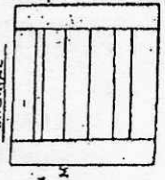

150MM X 25MM

ENDS
(2 NOS.)



SIDES
(2 NOS.)

TYPE NO.	DIMMS (MM)		
	A	B	C
1144	1100	400	400
1122	1100	200	200
634	600	500	400
633	600	300	300
1133	1100	300	300
1155	1100	500	500

ITEM NO.	DESCRIPTION	DRAWING NO.
03	NAILS	2 1/2 - 106
02	BATONS	100 X 30
01	PLANKS	25 X 150



CAUTION: THE WEIGHTS AND MEASUREMENTS OF THE BOILER COMPONENTS ARE THE PROPERTY OF BHARAT HEAVY ELECTRICALS LTD. AND ARE NOT TO BE REPRODUCED OR USED IN ANY MANNER WITHOUT THE WRITTEN PERMISSION OF BHARAT HEAVY ELECTRICALS LTD.

TYPE OF PRODUCT: TYPE 1144 1100 X 400 X 400MM
 OR NAME OF: 1122 1100 X 200 X 200 MM
 CUSTOMER/PROJECT: 634 600 X 500 X 400 MM
 633 600 X 300 X 300 MM

BHARAT HEAVY ELECTRICALS LTD.
 UNIT: BOILER PRESSURE BOILER PLANT,
 BHARAT HEAVY ELECTRICALS - BHEL

DESIGNER: [Signature] DATE: [Date]
 CHECKED: [Signature] DATE: [Date]
 APPROVED: [Signature] DATE: [Date]

SCALE: [Scale]
 WEIGHT (KG): [Weight]

DRAWING NO. 3-SH-B-004/B
 SHEET NO. 01

DRAWING NO. 3-SH-B-004/C

DETAIL OF ALL SIDES PRODUCTION INTERNALS

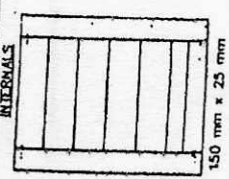

ENDS
2 Nos.

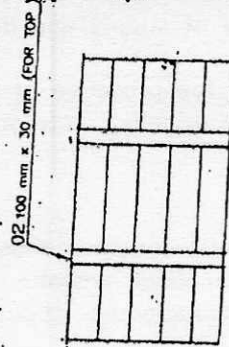

TOP & BASE
2 No.

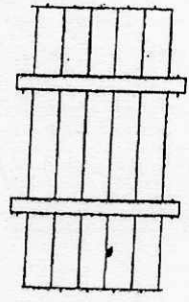

SIDES
2 Nos.

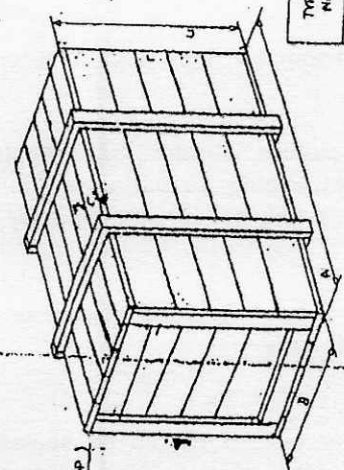

PRINTED BY
ORIGIN: GREEN COLOUR

TYPE No.	DIMENSIONS (mm)		
	A	B	C
654	600	500	400
10105	1050	1050	500

ITEM NUMBER	DESCRIPTION	DRAWING NUMBER	MATERIAL		UNIT WEIGHT	CLARITY
			CODE	SPEC		
03.	NAILS 2 1/2" - 10 C					
02.	BATTENS 100 x 30					
01.	BLANKS 25 x 150					

TYPE OF PRODUCT OR NAME OF CUSTOMER/PROJECT: TYPE: 654, 500x300x400, 10105, 1050x1050x500

Bharat Heavy Electricals Ltd
UNIT: HIGH PRESSURE BOILER PLANT
TRUCHIRAPPALLI - 620014

300-006

REV: 01 DATE: 01/01/01

ALTERED: CRO & APPC

REV TO LIST / OLD INC

DRIVING NO: 3-SH-B-004/C

TITLE: BOILER COMPONENT PACKING BOXES

5 6

300-B-SH-E
ON DRAWING

DETAIL OF ALL SIDES PROJECTION
INTERNAL

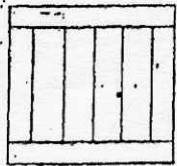

150 mm x 25 mm
ENDS
2 Nos.

02 100 mm x 30 mm (FOR TOP)
100 mm x 50 mm (FOR BOTTOM)

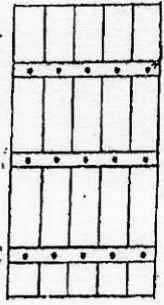

TOP & BASE
2 Nos.

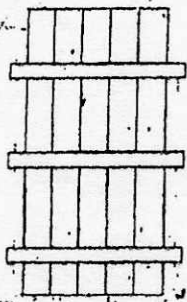

SIDES
2 Nos.

PRINTED BY
G. S. S. S.

TYPE No.	DIMENS. (mm)		
	A	B	C
16910	1600	900	1000

ITEM NO.	DESCRIPTION	DRAWING NUMBER	MATERIAL SPEC.		UNIT WEIGHT	QUANTITY
			MATERIAL CODE	GRADE		
03.	NAILS 2 1/2" - 3 1/2"					
02.	BATTENS 100 x 30 / 100 x 50					
01.	BLANKS 25 x 150					

TYPE OF PRODUCT: TYPE 16910 - 1600 x 900 x 1000
OR NAME OF CUSTOMER/PROJECT

Customer: Bhavet Heavy Electricals Ltd
UNIT: HIGH PRESSURE BOILER PLANT
THURUPAPALLI - 620014

TYPE: 300-B-SH-E

REV: 01 DATE: 10/10/80

ALL DIMENSIONS ARE IN MM

PROJECTION: 1:1

WEIGHT (Kg): 16910

REV TO LIST / QP INC

TITLE: BOILER COMPONENT
BUTTON BOXES

DRAWING NO.: 3-SH-B-005

KEY:

CAUTION: The information in this drawing is the property of BHAVET HEAVY ELECTRICALS LTD. It must not be used directly or indirectly in any way without the written consent of the company.

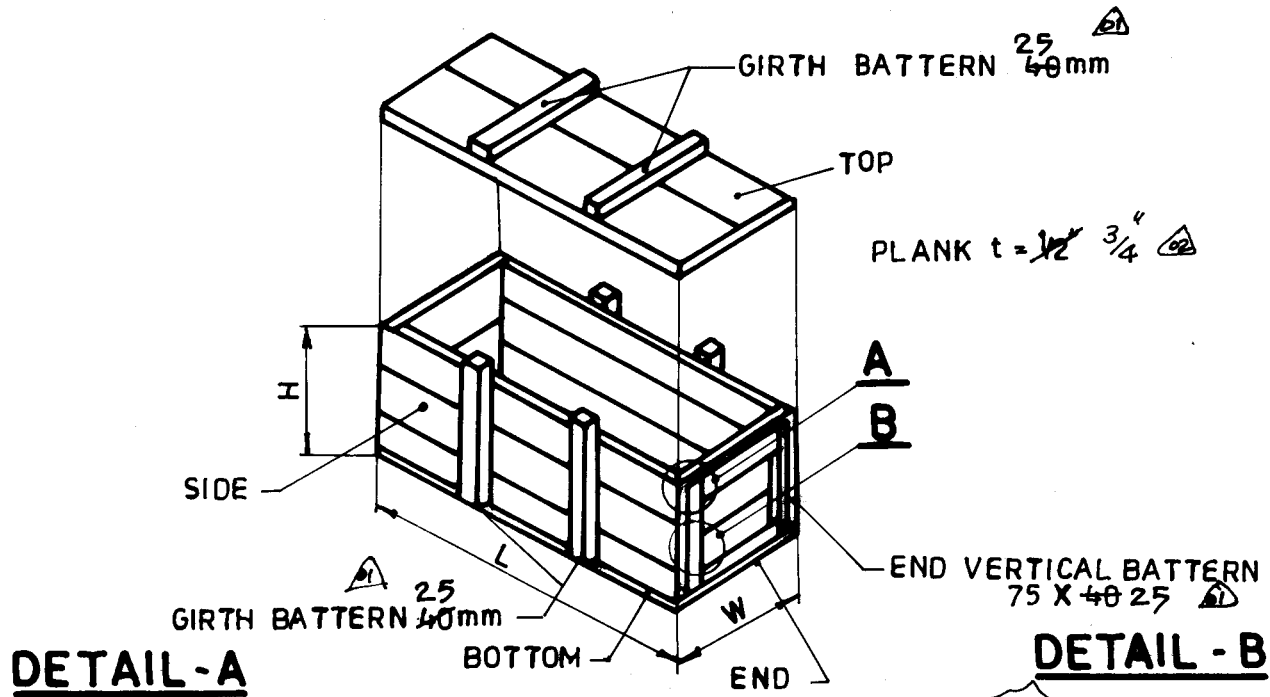

DETAIL - A

DETAIL - B

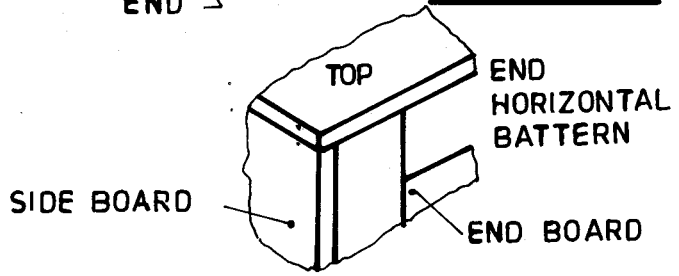
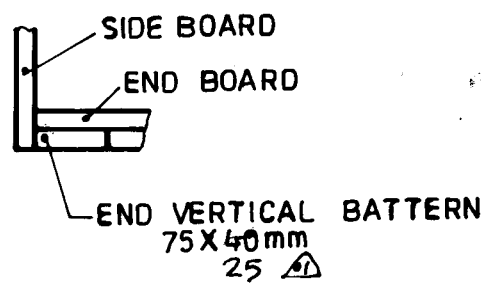

TYPE NO.				
	L	W	H	
1A	320	250	260	
1	320	250	430	
2	430	370	430	

NOTES:-

1. ALL DIMENSIONS ARE IN MM.
2. L, W, H ARE INNER DIMENSIONS OF THE BOX.
3. FOR TYPE NO 1A & 1 END VERTICAL BATTEN SHALL BE FLUSH ON BOTH ENDS WITH HARD BOARD TO WRITE THE DESPATCH DETAILS.



NO. OF PIECES	NAME - DIMENSIONS	SEMI - PRODUCT	FINAL MATERIAL	INITIAL MATERIAL	SCRAP SORT	NET Wt (kg)	GRAP Wt (kg)	DRAWING NO.	ITEM NO.
REMARKS				TOTAL NET Wt (kg)					
SCALE	DRAWN	R.N. R. NATRAJAN 24/10/92		ALTERATIONS	DATE	SIGNATURE	ALTERATION INDEX		
	CHECKED	K.S.S. 24/10/92		40mm To 25mm	26.9.94	[Signature]	01		
	APPROVED	D.K. 26.10.92		PLANK 3/4" WAS 1/2" NOTE 3 ADDED.	01.12.95	[Signature]	02		
	STDS. OFFICER			TRANS. COPY NO.					
	DATE								



TYPE	GROUP	OLD DRG.	NEW DRG.
TITLE		DRAWING NO.	
WOODEN PACKING CASE		4 - V - 4000 - 07183	

20-SPM-SH-00003
DRAWING NO.

ALL DIMENSIONS ARE IN MILLIMETRES

TYPE	DIMENSIONS			REMARKS
	A	B	C	
SPQ	710	630	600	1. ALL THE PLANKS ARE TO BE OF GIVEN THICKNESS ONLY, WIDTH OF PLANK 200 MM (MINIMUM) 2. BOTTOM 2 RUNNERS. THICKNESS MINIMUM 50 MM 50 MM THICK MINIMUM
SPR	850	630	670	
SPS	1000	770	670	
SPP	600	500	400	

APPROVED
23/4/03
Sr. Mgr / SHIPPING / SB

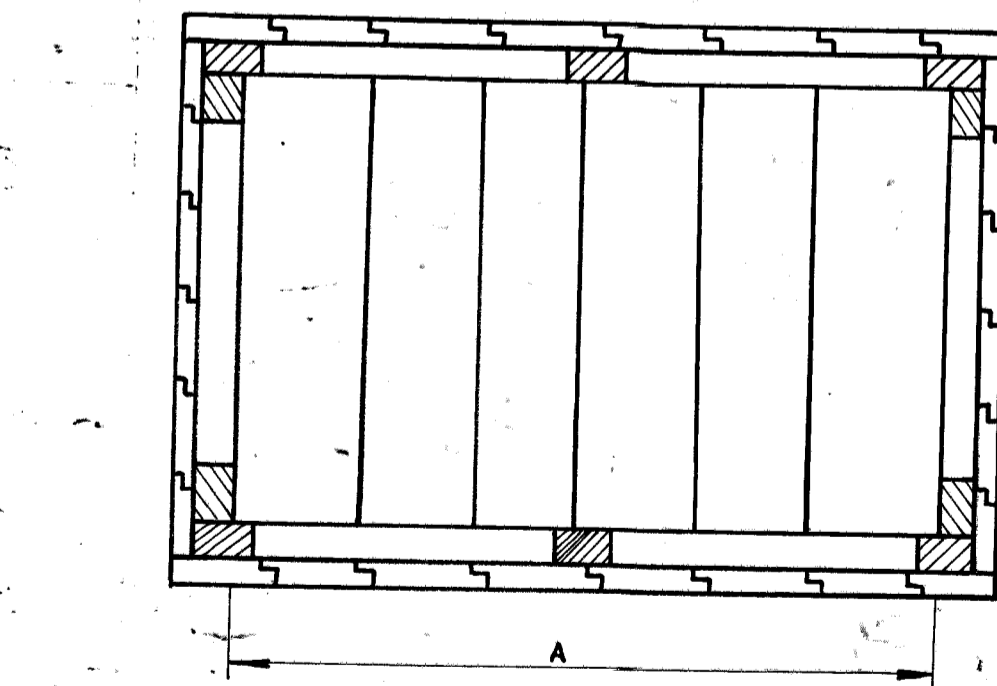
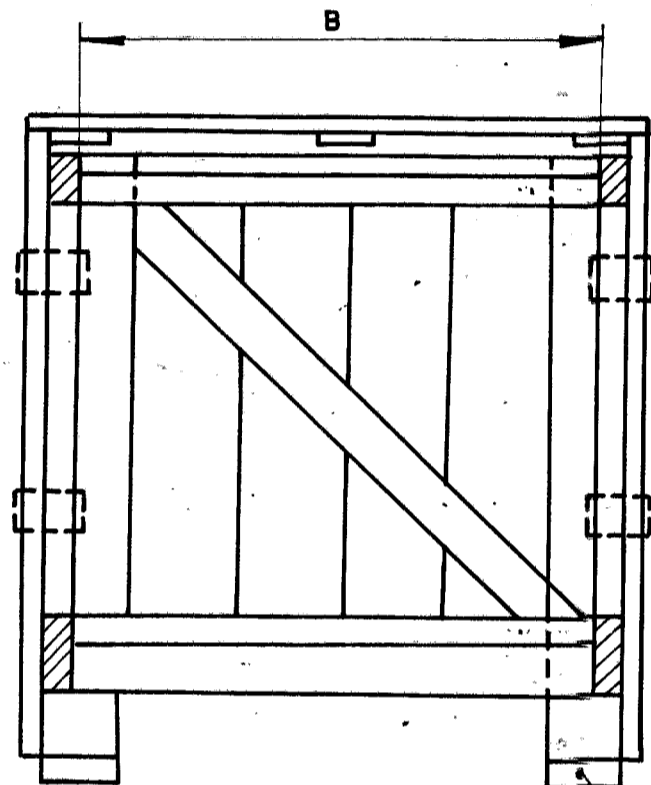
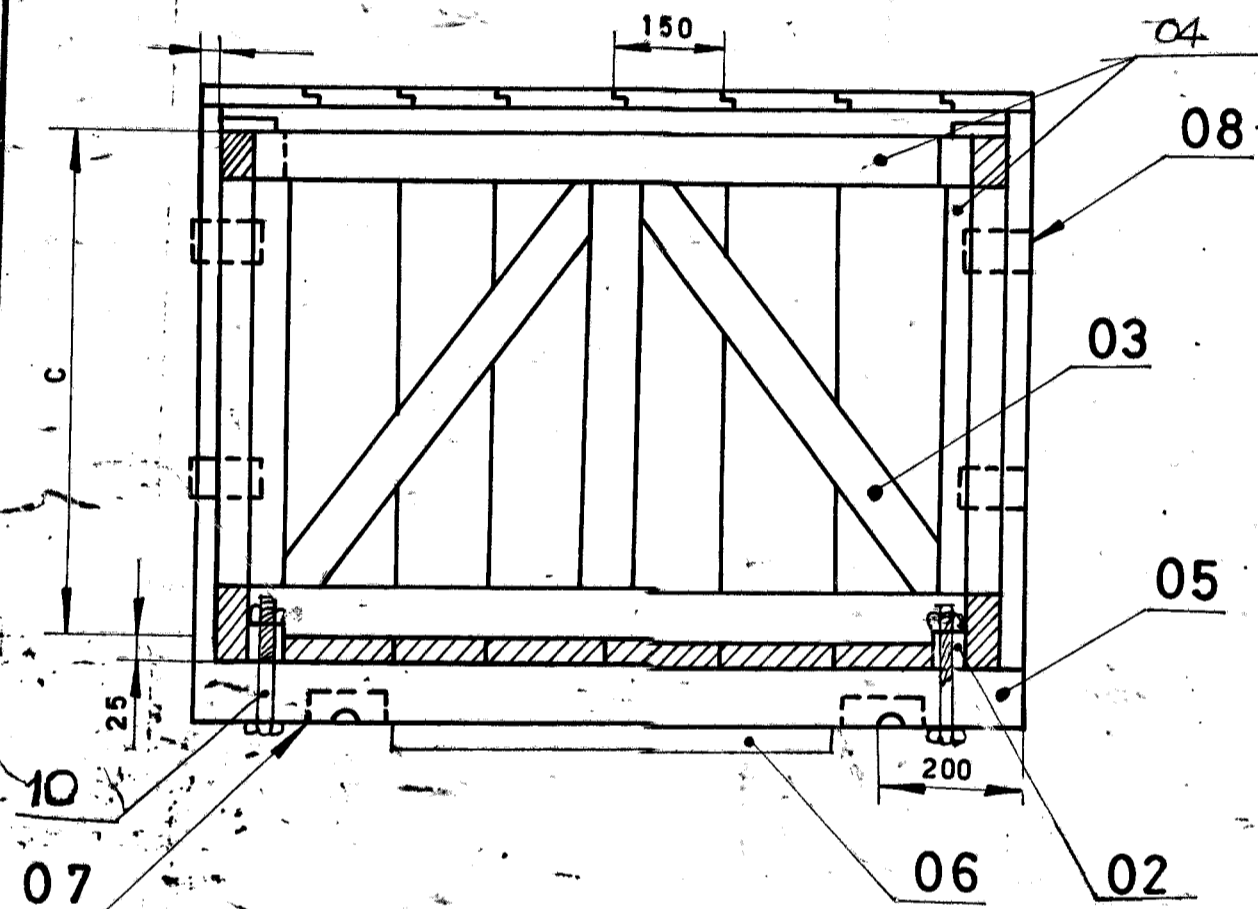
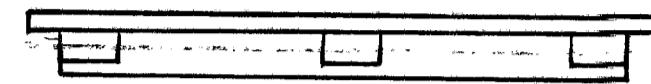
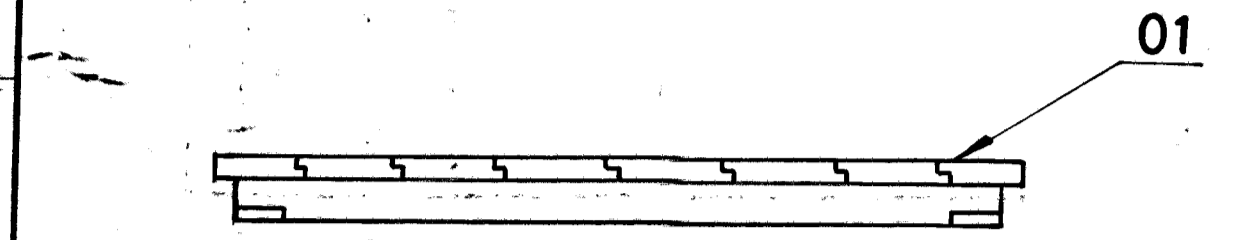

NOTES:-

- SOFT WOOD PLANKS 25
- END TRAVERS BAR 70X70
- DIAGONAL BRACE 80 X 30
- SOFT WOOD BATTERNS 80 X 30
- RUNNER 100 X 100MM
- RESTING BEAM 100 X 50 MM.
- SLING PLATE TO DRG. NO. 40-SPM-SH-00007.
- SIDE PLATE TO DRG. NO. 40-SPM-SH-00006.
- THE INSIDE OF ALL SIDES EXCEPT BOTTOM SHALL BE FULLY CURVED BY POLYETHYLENE SHEET SO AS TO AVOID ENTRY OF RAIN WATER.

ALL DIMENSIONS ARE IN MM.

A = LENGTH
B = BREADTH
C = HEIGHT

VAR NO.	ITEM NO.	DESCRIPTION	STD	SIZE/DRAWING NO.	ITEM NO.	MATL CODE	UNIT	UNIT WT.	QTY.	G.S.	ZONE
	10	BOLT AND NUT		M12							
	09	POLYETHYLENE (BLUE) SHEET									
	08	SIDE PLATE		40-SPM-SH-00006							
	07	SLING PLATE		40-SPM-SH-00007							
	06	RESTING BOARD		100X40							
	05	RUNNER		100 X 100							
	04	LATERAL PANEL & END PANEL, HORIZONTAL & VERTICAL SUPPORT		100 X 30							
	03	DIAGONAL BRACE		80 X 30							
	02	END TRAVERSE BAR		70 X 70							
	01	SHEETHING PLANK		150 X 25							

CAUTION: The information on this document is the property of BHARAT HEAVY ELECTRICALS LTD. It must not be used directly or indirectly in any way detrimental to the interest of the company.

REV	DATE	ALTERED	SVS
01	17.06.96	CHECKED	
ZONE	SPP INCLUDED		

TYPE OF PRODUCT OR NAME OF CUSTOMER/PROJECT		05-228/D	
BHARAT HEAVY ELECTRICALS LTD.		DRN	NAME
UNIT: HIGH PRESSURE BOILER PLANT.		CHD	INDCO SERVE
TIRUCHIRAPALLI-620014.		APPD	P. P. SELVAM
DEPT	GRADE OF UNTOLD DIM	SCALE	WEIGHT (KG.)
CODE	C / M / F		
TITLE		CARD CODE	REF. TO ASSY/OLD DRG.
BOILER COMPONENT (SPARES) PACKING BOX		U 01	2-SH-BW-022
DRAWING NO.		REV	
20-SPM-SH-00003 01			

CAUTION: The information on this document is the property of BHARAT HEAVY ELECTRICALS LTD. It must not be used directly or indirectly in any way detrimental to the interest of the company.

REV	DATE	ALTERED
		CHECKED <i>[Signature]</i>

ALL DIMENSIONS ARE IN MILLIMETRES

01.170696-SPY INCLUDED
-MATEL CORRECTED
L

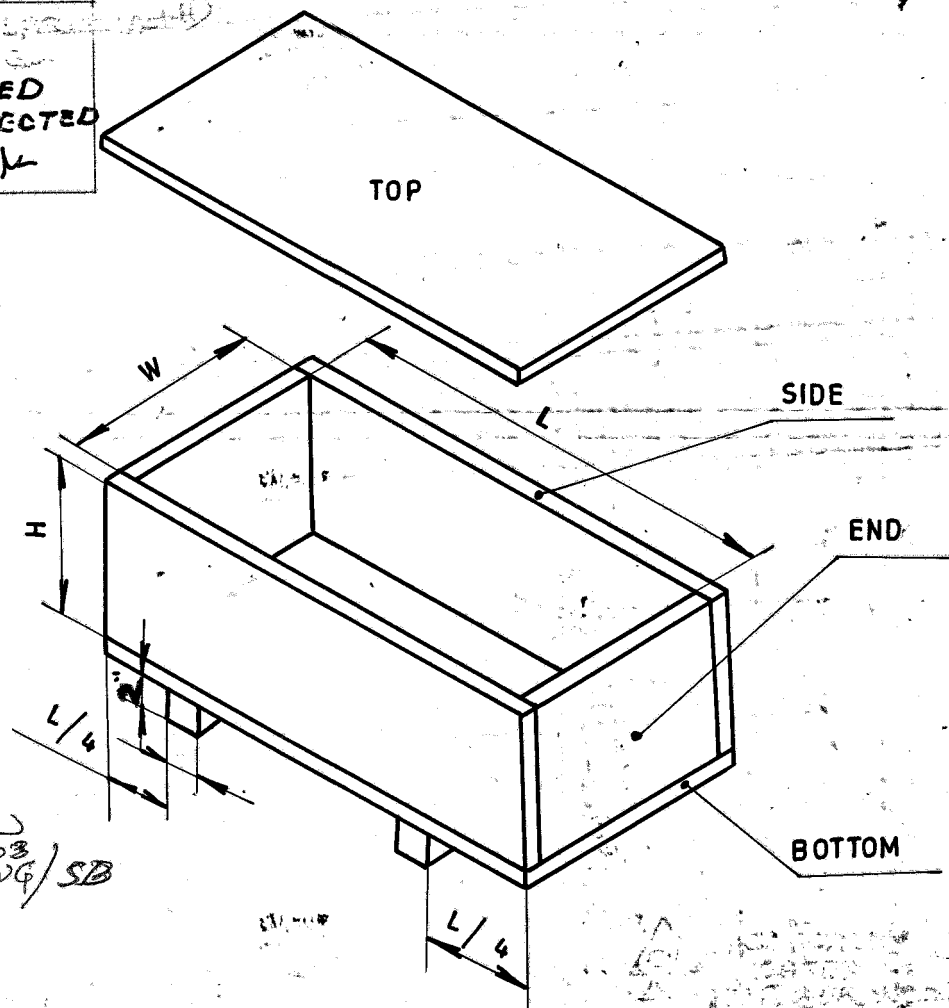

APPROVED
[Signature] 23/4/03
Sr MGR / SHIPPING / SB

TYPE NO.	INTERNAL DIMENSIONS		
	L	W	H
SPA	800	200 200	200 200
SPB	1500	200 200	200 200
SPC	2000	200 200	200 200
SPD	1100	200 200	200 200
SPE	200	200	200
SPY	450	200	200

PLANK THICKNESS (t) = 25 mm
LUG SIZE = 30mm X 30mm
WIDTH OF PLANK
MINIMUM 200 MM EACH
HEIGHT MINIMUM 200 MM

VAR NO.	DESCRIPTION	STD	MATL CODE	A	UNIT	UNIT WT.
			MATL SPECN.	C	DI	QTY

	BHARAT HEAVY ELECTRICALS LTD. UNIT: HIGH PRESSURE BOILER PLANT. TIRUCHIRAPALLI 620014.		DRN	NAME	SIGN	DATE	NO. OF VAR
			CHD	D-JAYABALAN	<i>[Signature]</i>	10-06-95	
			APPD	P.P. SELVAM	<i>[Signature]</i>	10-06-95	
DEPT VL	GRADE OF UNTOLD DIM	SCALE	WEIGHT (KG).	REF. TO ASSY. / OLD DRG.		ITEM NO.	NO. OF ITEMS
CODE 320	C / M / F	N.T.S	-	4V.MISC-90547			
TITLE			CARD CODE	DRAWING NO.		REV	
WOODEN BOX (FOR STEM & SMALL COMPONENTS)			U 01	40-SPM-SH-00001		01	

CAUTION: The information on this document is the property of BHARAT HEAVY ELECTRICALS LTD. It must not be used directly or indirectly in any way detrimental to the interest of the company.

REV	DATE	ALTERED	SVS
01	17-06-96	CHECKED	<i>[Signature]</i>

ALL DIMENSIONS ARE IN MILLIMETRES

DIMENSIONS CHANGED

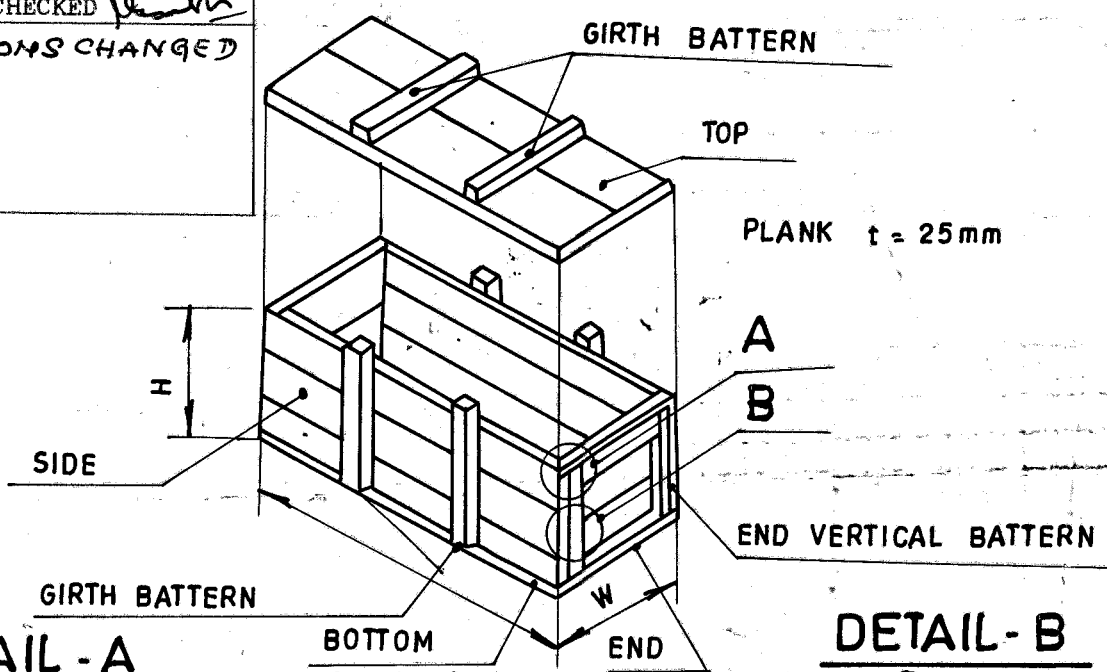

DETAIL - A

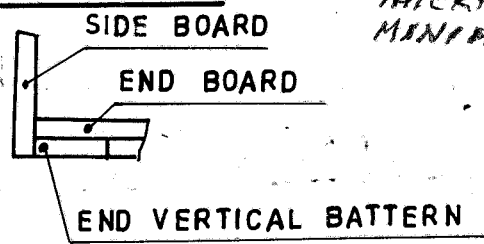

DETAIL - B

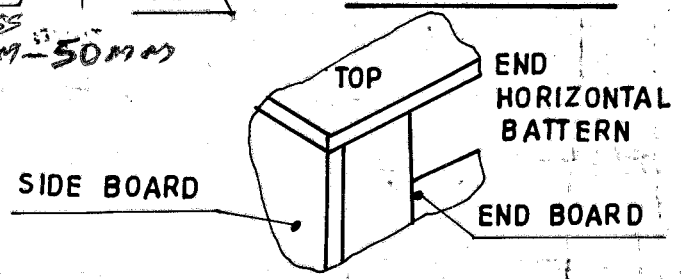

NOTES:

- L X W X H ARE INNER DIMNS. OF THE BOX.
- GIRTH BATTERNS: ADDL. 2 NOS. FOR BOXES EXCEEDING LENGTH 1000 mm & UPTO 2000 mm.
- GIRTH BATTERNS: ADDL. 3 NOS. FOR BOXES EXCEEDING 2000MM LENGTH.
- BOTTOM RUNNER MINIMUM THICKNESS - 50 mm
- MINIMUM WIDTH OF PLANK - 200 EACH ONLY.

TYPE NO.	INTERNAL DIMNS.			BATTERNS	MAX. NO OF PLANKS EACH SIDE
	L	W	H		
SPF	320	250	260	75 X 25	2
SPG	320	250	430	75 X 25	2
SPH	430	370	430	75 X 25	2
SPI	1100	400	400	100 X 25	2
SPJ	1000 1500	500	400	150 X 25	01/2
SPK	2000	500	400	150 X 25	2
SPL	2500	400	400	150 X 25	2
SPM	1600	450	450	150 X 30	2
SPN	3000	400	400	150 X 30	2
SPO	2500	600	500	150 X 30	3

<p>BHARAT HEAVY ELECTRICALS LTD. UNIT: HIGH PRESSURE BOILER PLANT. TIRUCHIRAPALLI 620014.</p>	DRN	NAME	SIGN.	DATE	NO. OF VAR
	CHD	INDCO SERVE	<i>[Signature]</i>	10-06-95	
	APPD	D-JAYABALAN	<i>[Signature]</i>	10-06-95	
DEPT	GRADE OF UNTOL. DIM	SCALE	WEIGHT (KG).	REF. TO ASSY./OLD DRG.	ITEM NO.
CODE	C / M / F			4V-4000-07183	NO. OF ITEMS
TITLE			CARD CODE	DRAWING NO.	REV
WOODEN BOX			U 01	40-SPM-SH-00002 01	

B/A - 100-B-HS-2
 20/01/2015

FOR TOLERANCES OF UNTOUCHED DIMENSIONS TURN TO MANUFACTURE REFER PLANT STD. NO TP-023 0299

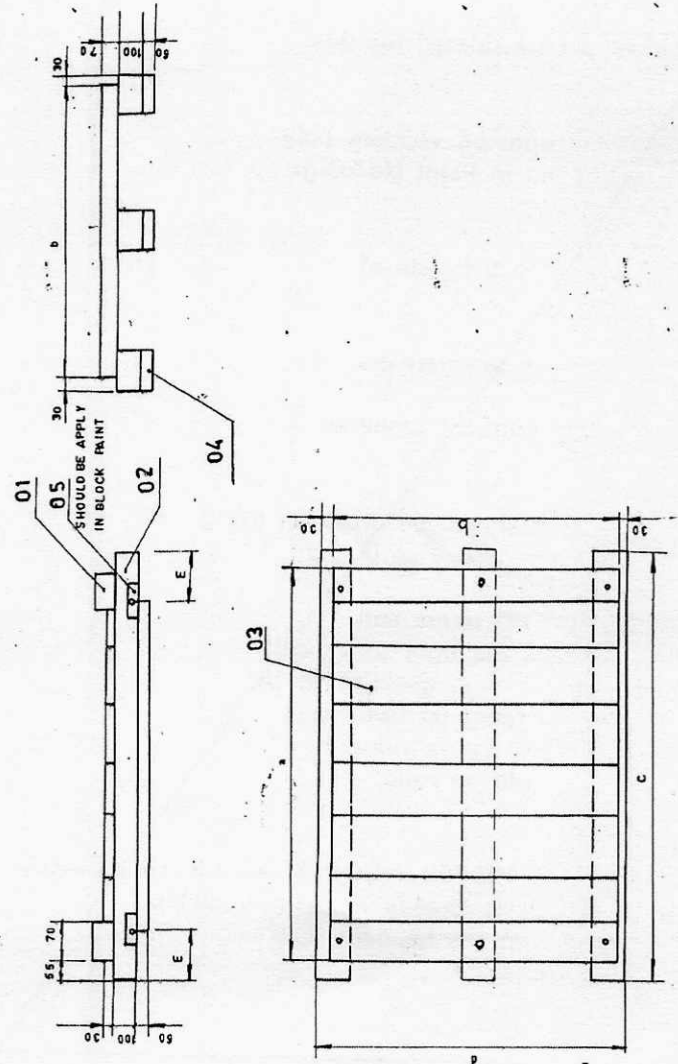

E	150-150	150-150	200-200	200-200	200-200
d	660	960	960	760	760
C	1010	1310	1410	1610	1610
b	600	900	900	700	700
a	900	1200	1300	1500	1500
ITEM NO.	TYPE	TYPE	TYPE	TYPE	TYPE
	966	1296	1399	1577	1577

04	BASE RESTING BOARD	710 X 100 X 50	1010 X 100 X 50	1010 X 100 X 50	210 X 100 X 50
03	BASE PLANKS	600 X 150 X 30	900 X 150 X 30	900 X 150 X 30	700 X 150 X 30
02	BASE RENNERS	1010 X 100 X 100	1310 X 100 X 100	1410 X 100 X 100	1610 X 100 X 100
01	BASE END TRAVES	600 X 70 X 70	900 X 70 X 70	900 X 70 X 70	700 X 70 X 70
ITEM NO	DESCRIPTION	TYPE : 966	TYPE : 1296	TYPE : 1399	TYPE : 1577

CAUTION: The information on this drawing is the property of BHARAT HEAVY ELECTRICALS LTD. It must not be used directly or indirectly in any form or by any means without the written consent of the interest of the company.

TYPE OF PRODUCT OR NAME OF CUSTOMER/PROJECT
 Bharat Heavy Electricals Ltd
 UNIT: HIGH PRESSURE BOILER PLANT
 TRICHURAPALLI - 620014

DATE: 20/01/15
 DRAWN BY: T. XAVIER
 CHECKED BY: M. KALAIMARAN
 APPROVED BY: P. SALLARIGUNATHAN

SCALE: 1:1
 WEIGHT (kg):

REV: 01
 DATE: 20/01/15
 BY: T. XAVIER
 APPR: P. SALLARIGUNATHAN

TITLE: BASE SHOOK

DRAWING NO: 2 SH B 001 A/B

DETAILS OF WOODEN BOX DIMENSIONS, WEIGHT AND VOLUME

BOX	BOX WT	INSIDE DIMENSION IN MM			OUTSIDE DIMENSION IN MM			VOLUM IN
TYPE	(KG)	LENGTH	BREADTH	HEIGHT	LENGTH	BREADTH	HEIGHT	CUBIC Mtr.
1A	10	320	250	260	450	300	280	0.038
1	15	320	250	430	450	370	580	0.097
2	25	430	370	430	570	490	590	0.165
3	65	670	670	470	770	770	700	0.415
4	75	710	630	600	810	730	840	0.497
5	95	850	630	670	950	730	900	0.624
6	100	1000	770	670	1100	870	915	0.876
7	80	1100	430	670	1200	520	900	0.562
8	170	1200	1200	900	1300	1300	1150	1.944
10	155	1300	770	1050	1400	860	1320	1.589
11	225	2500	850	800	2600	950	1050	2.594
12	305	2000	1500	1200	2100	1600	1400	4.704
14	260	1850	1050	1250	1950	1150	1480	3.319
15	180	2000	800	800	2100	900	990	1.871
16	345	3000	1050	1000	3100	1220	1250	4.728
17	470	2600	1500	1600	2700	1600	1830	7.906
29	390	3600	1100	1100	3700	1220	1350	6.094
21	25	250	250	600	380	380	770	0.111
22	30	250	250	880	380	380	1040	0.150
23	25	300	300	700	425	425	850	0.154
24	45	380	380	880	510	510	1050	0.273
27	80	570	570	1400	700	700	1560	0.764
28	105	575	575	1875	710	710	2040	1.028
62	130	600	1125	1000	700	1325	1200	1.113
63	55	800	370	750	900	500	800	0.360
51	260	2775	850	680	2870	950	950	2.590
52	255	2000	950	740	2100	1050	1050	2.315
53	220	1600	1120	700	1700	1220	980	2.033
54	490	2500	1900	1200	2600	2000	1450	7.540
55	525	2900	1900	1400	3000	2000	1650	9.900
56	370	3000	1000	900	3100	1100	1200	4.092
57	450	3200	2200	850	3300	2300	1100	8.349
58	325	2200	1100	750	2300	1200	1050	2.898
60	485	2300	2200	1200	2350	2300	1500	8.108
61		675	675	2000				
304 MM=1 FEET								