



BHARAT HEAVY ELECTRICALS LTD.
 (A GOVT. OF INDIA UNDERTAKING)
 P.O BHEL Jhansi - 284129, INDIA
 Tel.:0510-277001/2412260 Fax: 2412120
 Email : mmx@bheljhs.co.in

PURCHASE ENQUIRY

ENQ NO/DT: E1830003 06/06/23
 REV NO/DT: 0 06/06/23

PAGE 1
4

PLEASE SEND YOUR BEST QUOTATION AS PER TERMS & CONDITIONS AND REMARK MENTIONED UNDERNEATH.	
Enq Due on:	21-06-23 WEDNESDAY
Close at:	13:15 Open at: 14:00
Matcat:	181004 RIP BUSHING
Validity:	120 days from Technical bid opening date
IEM:	
TOP:	See Special Remarks
RA:	BHEL reserves the right to conduct RA
Est. Value:	Item wise
Bid Type:	TWO BID
Tot Item:	3
Delivery:	FOR Jhansi
E-Proc:	Yes

REQUIRED:

ITEM NO : 1 PSL QTY/UM: 9.00 NO
 MATL CODE : TR173073A602 PO QTY /UM: 9.00 NO
 DESTINATION: JS

DESCRIPTION	DELIVERY	QUANTITY (PSL UM)
245 KV 1250 AMP (MIN.) 300CT LENGTH	JUN-23	3.00
RIP H.V. BUSHING WITH CREEPAGE	JUL-23	6.00
DISTANCE OF 7595 MM AS PER ATTACHED ANNEXURE		

ITEM NO : 2 PSL QTY/UM: 9.00 NO
 MATL CODE : TR173073A603 PO QTY /UM: 9.00 NO
 DESTINATION: JS

DESCRIPTION	DELIVERY	QUANTITY (PSL UM)
145 KV 1250 AMP (MIN.) 300CT LENGTH	JUN-23	3.00
RIP I.V. BUSHING WITH CREEPAGE	JUL-23	6.00
DISTANCE OF 4495MM AS PER ATTACHED ANNEXURE.		

ITEM NO : 3 PSL QTY/UM: 9.00 NO
 MATL CODE : TR173073A616 PO QTY /UM: 9.00 NO
 DESTINATION: JS

DESCRIPTION	DELIVERY	QUANTITY (PSL UM)
52 KV.3150 AMP. 300CT LENGTH	JUN-23	3.00
RIP L.V.BUSHING WITH CREEPAGE	JUL-23	6.00
DISTANCE OF 1612mm. AS PER ATTACHED ANNEXURE.		

SPECIAL REMARKS:

- ENQUIRY IS FLOATED IN TWO BID SYSTEM THRU E-PROCUREMENT (<https://eprocurebhel.co.in>) TO PROCURE THE ITEM MENTIONED IN THE DESCRIPTION.
- TECHNICAL- COMMERCIAL MANDATORY SHEET AND TECHNICAL SPECIFICATION IS UPLOADED AT OUR E-PROCUREMENT PORTAL i.e. <https://eprocurebhel.co.in> ITSELF.DEVIATION SHEETS CAN BE ATTACHED SEPARATELY.
- SUBMISSION OF TENDER DOCUMENTS THROUGH OTHER THAN E-PROCUREMENT MODE SHALL NOT BE ACCEPTED.
- PLEASE QUOTE WITH FIRM RATES OTHERWISE OFFER WILL BE BY-PASSED.
- GUARANTEE AND TEST CERTIFICATE IS REQUIRED IN TRIPLICATE ALONGWITH EACH SUPPLY.
- DRAWING WITH DETAILS AND TYPE TEST REPORT SHALL BE SUBMITTED ALONG WITH OFFER.
- DRAWING WITH DETAILS AND ALL RELEVANT DOCUMENTS SHALL BE SUBMITTED ALONGWITH OFFER. PLEASE SUBMIT DRAWINGS ALONGWITH TECHNO ?COMMERCIAL OFFER.
- EQUIPMENT OFFERED SHALL HAVE TYPE TEST CERTIFICATES FROM ACCREDITED



BHARAT HEAVY ELECTRICALS LTD.
 (A GOVT. OF INDIA UNDERTAKING)
 P.O BHEL Jhansi - 284129, INDIA
 Tel.:0510-277001/2412260 Fax: 2412120
 Email : mmx@bheljhs.co.in

PURCHASE ENQUIRY

ENQ NO/DT: E1830003 06/06/23
 REV NO/DT: 0 06/06/23

PAGE 2
4

- LABORATORY (ACCRDITED BASED ON ISO/IEC GUIDE25 /17025 OR EN 45001 BY NATIONAL ACCREDITATION BODY OF THE COUNTRY WHERE LAB IS LOCATED) OR WITNESSED BY THIRD PARTY AS PER IS/IEC. THE TYPE TEST REPORT SHALL NOT BE OLDER THAN FIVE YEARS AND SHALL BE VALID UP TO EXPIRY OF VALIDITY OF OFFER.
9. IN CASE SUPPLIER DOES NOT HAVE TYPE TEST REPORT OF IDENTICAL BUSHING. SAME IS TO BE CONDUCTED BY SUPPLIER ON ONE NO BUSHING AS PER IS/IEC WITHOUT AFFECTING DELIVERY & PRICE IMPLICATION TO BHEL JHANSI.
 10. SUCCESSFUL VENDOR TO START MANUFACTURING ONLY AFTER DRAWING APPROVAL FROM BHEL/CUSTOMER.
 11. LOADING SHALL BE APPLICABLE FOR NON-ACCEPTANCE OF NIT TERMS AND CONDITIONS.
 12. INSPECTION BY BHEL/CUSTOMER/TPI AT SUPPLIER WORKS/BHEL WORKS.
 13. QUANTITY IS DIVIDABLE IN THE SET OF THREE. TENDER QUANTITY BENEFIT FOR MSE AND MII (CLASS-I) VENDORS WILL BE APPLICABLE ACCORDINGLY AGAINST EACH ITEM. I.E. FOR MSE (SMALL AND MICRO), TENDER QUANTITY BENEFIT SHALL BE 3 NOS AGAINST EACH LINE ITEM. FOR MII (CLASS-I) VENDOR TENDER QUANTITY BENEFIT SHALL BE 6 NOS AGAINST EACH LINE ITEM
 14. NO TENDER FEES IS APPLICABLE.
 15. BHEL SHALL BE RESORTING TO REVERSE AUCTION (RA) (GUIDELINES AS AVAILABLE ON WWW.BHEL.COM) FOR THIS TENDER. RA SHALL BE CONDUCTED AMONG THE TECHNO-COMMERCIALLY QUALIFIED BIDDERS PRICE BIDS OF ALL TECHNO-COMMERCIALLY QUALIFIED BIDDERS SHALL BE OPENED AND SAME SHALL BE CONSIDERED FOR RA. IN CASE ANY BIDDER(S) DO(ES) NOT PARTICIPATE IN ONLINE REVERSE AUCTION, THEIR SEALED ENVELOPE PRICE BID ALONG WITH APPLICABLE LOADING, IF ANY, SHALL BE CONSIDERED FOR RANKING.
 16. TENDER EVALUATION WILL BE IN INR ON TOTAL COST TO BHEL ON FOR BHEL JHANSI BASIS.
 17. DELIVERY QUOTED IN ENQUIRY IS TENTATIVE ONLY. SUPPLIERS TO QUOTE THEIR OWN DELIVERY TIME.
 18. OFFER OF ONLY WBSETCL APPROVED VENDORS SHALL BE CONSIDERED IN THE ENQUIRY. TECHNICALLY QUALIFIED VENDOR HAS TO ORGANIZE M/S WBSETCL APPROVAL BEFORE PRICE BID OPENING.
 19. ENQUIRY IS FLOATED AS OPEN TENDER. OFFER IS SOUGHT ONLY FROM LOCAL SUPPLIERS.
 20. OIL END OF ALL THE BUSHING SHALL BE SUPPLIED WITH METALLIC ENCLOSURE FOR LONG TERM STORAGE.
 21. QUANTITY UNDER INDIVIDUAL LINE ITEM MAY VARY +/-30.0 % DURING EXECUTION.
 22. QUALITY PLAN IS APPLICABLE.
 23. APPLICABLE ANNEXURES/DRAWINGS/QP IS ATTACHED WITH ENQUIRY DOCUMENTS.

In case the bidder has not submitted PAN No, TIN No. and E-mail ID, the bidder has to submit the same along with the copy of PAN No and TIN No. Else his offer will be liable to be rejected.

If you are not in a position to quote due to any reason, you must send regret letter titled enquiry no. etc, failing which you may not be considered for sending future enquiries.

ENCLOSERS:



BHARAT HEAVY ELECTRICALS LTD.
(A GOVT. OF INDIA UNDERTAKING)
P.O BHEL Jhansi - 284129, INDIA
Tel.:0510-277001/2412260 Fax: 2412120
Email : mmx@bheljhs.co.in

PURCHASE ENQUIRY

ENQ NO/DT: E1830003 06/06/23
REV NO/DT: 0 06/06/23

PAGE 3
4

FOR AND ON BEHALF OF
BHARAT HEAVY ELECTRICALS LTD

RAHUL KUMAR
DY MANAGER (TRFR MM)
Email:-rahulkumar.r@bhel.in

* * * * * E N D O F P U R C H A S E E N Q U I R Y * * * * *

NOTE :

- * THE BIDDER IS INFORMED THAT THE GENERAL TERMS & CONDITIONS OF ENQUIRY (JHS 2055A Rev 03) WHICH ARE UPLOADED AT <https://www.bheljhs.co.in/apps/sip/index.php> AT (TERMS & CONDITION -> FOR ENQUIRY) LINK, ARE TO BE READ BY THE BIDDER BEFORE SUBMITTING QUOTE IN THE ENQUIRY. BHEL SHALL CONSTRUE THE PARTICIPATION BY THE BIDDER IN ENQUIRY AS ACCEPTANCE TO THE GENERAL TERMS AND CONDITIONS OF ENQUIRY.
- * SUPPLIERS ARE REQUESTED TO INFORM US WITH VALID CERTIFICATE,IF THEY ARE REGISTERED UNDER MSMED ACT'2006.(APPLICABLE FOR INDIAN SUPPLIERS ONLY).
- * FOR SUPPLIERS SUPPLYING FROM OUTSIDE THE LOCAL AREA OF BHEL JHANSI,ENTRY TAX WILL BE APPLICABLE.SUPPLIERS SHOULD NECESSARILY INDICATE RATE OF ENTRY TAX SEPARATELY WHEREVER APPLICABLE.THEY SHOULD ALSO MENTION THE ENTRY TAX CHARGED SAPARATELY IN THE INVOICE.
- * FOR SUPPLIERS SUPPLYING FROM OUTSIDE UP,IN CASE THE OFFER IS SILENT ON ENTRY TAX, IT SHALL BE LOADED SUITABLY WITH THE APPLICABLE RATES
- * IN CASE IF THERE IS ANY DIFFERENCE BETWEEN THE 'SPECIAL REMARKS/ANNEXURES' OF THE ENQUIRY AND THE PREPRINTED TERMS & CONDITIONS (REF JSC140/M2053), THE REQUIREMENT GIVEN IN REMARKS WILL PREVAIL.
- * Reference Sl. No. 2(B) of General Terms and Conditions regarding option for offer submission through Email addressed to tenderbox.jhs@bhel.in , please note that the maximum mail size including attachments should not exceed 20 MB , otherwise the offer shall not be delivered due to size limitation and bidder sending mail attachments more than 20 MB will have no claim whatsoever on the subject tender . Also due to any technical snag , if offer has not reached tenderbox.jhs@bhel.in , it will be bidder's sole responsibility to ensure offer submission through alternate routes before the due date and time .BHEL will not entertain any such claim for non-receipt of offer on time .



BHARAT HEAVY ELECTRICALS LIMITED JHANSI - 284120
(A Gov't of India undertaking)
Material Management

..
(Part-A)

TECHNO COMMERCIAL BID FOR ENQUIRY NO. E1830003

Mandatory sheet regarding instruction to bidders for compliance for bidders

QUOTATION NO......**DATE**.....

SUPPLIER'S NAME:

Sl. no.	Particulars	Supplier's Confirmation
1-	Complete acceptance for supply of items as per Purchase / Tech. specification mentioned in the enquiry.	<input type="checkbox"/> Accepted
1A)	In case of acceptance to 1 above and wherever needed, successful bidder has to submit duly seal & signed copy of Drgs, Purchase / Tech. specification etc. as token of acceptance before placing order.	<input type="checkbox"/> Accepted
2-	Acceptance to all special remarks / General Terms & Condition JHS 2055A rev 03 of enquiry. (https://jhs.bhel.com/apps/sip/eng_tems_current.pdf)	<input type="checkbox"/> Yes
3-	Guarantee / Warrantee / Conformance / Test Certificate (along with supply) as specified in enquiry will be provided.	<input type="checkbox"/> Yes
4-	(a) Delivery period from date of PO issue/Drawing approval, whichever is later.Days.
	Taxes & Duties Extra :-	<input type="checkbox"/> Accepted
5-	GST%
	Price Bid submitted as per attached price bid format only	<input type="checkbox"/> Yes
6-	Terms of Delivery- BHEL prefer delivery on F.O.R BHEL Jhansi (including freight & Insurance) basis. Hence quote rate on F.O.R BHEL Jhansi basis.	<input type="checkbox"/> Yes
7-	Terms of Delivery on F.O.R BHEL Jhansi basis.	<input type="checkbox"/> Accepted
8	Basic rate quoted is inclusive of Packing & forwarding	<input type="checkbox"/> Yes
8a-	If answer to sl. No. 8 is 'No', state Packing & forwarding charges as % of basic rate or actual	Rs..... or.....%
9-	Acceptance for Prices on firm basis and no PVC is applicable	<input type="checkbox"/> Yes
10-	Acceptance for 120 days Validity of offer from date of tender opening.	<input type="checkbox"/> Yes
11-	Inspection – Material may be source inspected by BHEL / Customer / Third party. However, Final inspection for acceptance of quality and quantity shall be done at BHEL's works after receipt of material and results shall be binding on the suppliers	<input type="checkbox"/> Accepted
12-	Liquidated Damage / Penalty - Failure to supply by the time specified in the order will make the supplier liable to pay unconditional penalty of 1/2% of the price of the goods in arrear (delayed and not supplied) per week or part thereof, subject to a maximum of 10% of the order value unless agreed otherwise.	<input type="checkbox"/> Accepted

**BHARAT HEAVY ELECTRICALS LIMITED JHANSI - 284120**

(A Gov't of India undertaking)

Material Management

13-	Risk Purchase - If the material is not supplied within stipulated delivery indicated in PO, BHEL shall have the option to purchase the material from other sources at the supplier's risk & cost.	<input type="checkbox"/> Accepted
14-	Payment Terms (For indigenous bidders) - 100 % payment within 90 days (45 days for MSE / NSIC registered suppliers as per relevant act in force) from the date of receipt of material and submission of clear and admissible bill, subject to acceptance of material at BHEL, on direct presentation of the documents. In case of dispatch of material to site directly, site certification for receipt of materials is required unless otherwise provided for in the PO. Any deviation from the above payment terms, if accepted (by BHEL), shall be loaded @ SBI base rate (as on date of Part I bid opening) + 6%, for the purpose of bid evaluation .	<input type="checkbox"/> Accepted
15A)	Guarantee - In Case an order is placed, supplier shall be required to guarantee for smooth and satisfactory performance of the equipment for a period of 24 months from the date of receipt at BHEL Jhansi and certificate must be issued to this effect. Necessary instruction booklets for operation and maintenance are to be sent with supply, where applicable	<input type="checkbox"/> Accepted
15B)	"The Bidder along with its associate/ collaborators/ sub-contractors/ sub-vendors/ consultants/ service providers shall strictly adhere to BHEL Fraud Prevention Policy displayed on BHEL website http://www.bhel.com and shall immediately bring to the notice of BHEL Management about any fraud or suspected fraud as soon as it comes to their notice."	<input type="checkbox"/> Accepted
16	Supplier has to provide 15 Days advance intimation for inspector deputation on vendor works. Further dispatch clearance will be given within 4 days of submission of report to BHEL/CUSTOMER. Vendor to take care of other elements of inspection such as Inspection duration, Inspection report submission, arrangement of Packing, transportation duration from Supplier works to BHEL Jhansi etc. to meet delivery dates of PO.	<input type="checkbox"/> Accepted
17-	Whether you are a MSME Vendor-Yes/No If yes, please fill up the following details as per UDYAM Certificate- UDYAM Certificate- Udyam Registration No..... Type of Enterprises- (Micro/Small/Medium) Activity- (Manufacturer/Service Provider)	<input type="checkbox"/> Accepted



BHARAT HEAVY ELECTRICALS LIMITED JHANSI - 284120

(A Gov't of India undertaking)

Material Management

18-	<p>A bidder shall not have conflict of interest with other bidders. Such conflict of interest can lead to anti-competitive practices to the detriment of Procuring Entity's interests. The bidder found to have a conflict of interest shall be disqualified. A bidder may be considered to have a conflict of interest with one or more parties in this bidding process, if:</p> <p>a) they have controlling partner (s) in common; Or b) they receive or have received any direct or indirect subsidy/ financial stake from any of them; Or c) they have the same legal representative/agent for purposes of this bid;</p> <p>Or d) they have relationship with each other, directly or through common third parties, that puts them in a position to have access to information about or influence on the bid of another Bidder, Or e) Bidder participates in more than one bid in this bidding process. Participation by a Bidder in more than one Bid will result in the disqualification of all bids in which the parties are involved. However , this does not limit the inclusion of the components/ sub-assembly/ Assemblies from. one bidding manufacturer in more than one bid; Or f) In cases of agents quoting in offshore procurements, on behalf of the ir principal manufacturers, one agent cannot represent two manufacturers or quote on their behalf in a particular tender enquiry. One manufacturer can also authorize only one agent/dealer. There can be only one bid from the following: 1. The principal manufacturer directly or through one Indian agent on his behalf; and 2. Indian/foreign agent on behalf of only one principal, ? Or g) A Bidder or any of its affiliates participated as a consultant in the preparation of the design or technical specifications of the contract t hat is the subject of the Bid, Or h) In case of a holding company having more than one independently manufacturing units, or more than one unit having common business owner ship/management, only one unit should quote. Similar restrictions would apply to closely related sister companies. Bidders must proactively declare such sister/ common business/ management units in same/ similar line of business.</p>	<input type="checkbox"/> Accepted
-----	---	-----------------------------------



BHARAT HEAVY ELECTRICALS LIMITED JHANSI - 284120

(A Gov't of India undertaking)

Material Management

- 1) If rates are disclosed in covering letter or through any other format along with techno-commercial bid (Part-I), offer may not be considered.
- 2) Evaluation of bid will be done on landed cost to BHEL basis. Offers will be loaded for the deviation(s), if any, suitably. Hence, please quote accordingly.
- 3) In case of non-acceptance of BHEL L.D. clause, the suitable loading up to 10% maximum shall be done on supplier's quoted rate to derive the L-1 Status.

In case of any discrepancy/deviation in terms & conditions accepted in mandatory sheet and condition given in the offer, acceptance given on mandatory sheet shall be considered.

Signature of Supplier & seal :

Date :

Name of contact person :

Cell No. :

Landline with STD code & E-mail :

SI. No.	REQUIREMENT	Bidder's Response
1	Bidders should be customer M/s WBSETCL approved vendor. Bidder to submit customer M/s WBSETCL approval letter in this regard or vendor should appear in the approved vendor list of M/s WBSETCL.	<input type="checkbox"/> YES <input type="checkbox"/> Submitted
2	In case, the bidder is not customer M/s WBSETCL approved vendor. The bidder to arrange the vendor approval from customer M/s WBSETCL before price bid opening.	<input type="checkbox"/> Yes



BHARAT HEAVY ELECTRICALS LIMITED, JHANSI
TRANSFORMER ENGINEERING DEPARTMENT
ANNEXURE-RIP BUSHING

1. Bushings shall be robust and designed for adequate cantilever strength to meet the requirement of seismic condition, substation layout and movement along with the spare Transformer with bushing erected and provided with proper support from one foundation to another foundation within the substation area. The electrical and mechanical characteristics of bushings shall be in accordance with IS 2099 & IEC: 60137/DIN 42530. All details of the bushing shall be submitted for approval and design review.
2. Bushing for voltage above 52 kV shall be RIP (Resin Impregnated paper) / RIS (Resin Impregnated Synthetic) / RIF (Resin Impregnated Fiberglass) condenser type with composite polymer insulator (housing).
3. RIP type bushing shall be provided with tap for capacitance and tan delta test. Test taps relying on pressure contacts against the outer earth layer of the bushing is not acceptable.
4. Bushings of identical rating shall be interchangeable to optimise the requirement of spares.
5. Polymer/composite insulator shall be seamless sheath of a silicone rubber compound. The housing & weather sheds should have silicon content of minimum 30% by weight. It should protect the bushing against environmental influences, external pollution and humidity. The interface between the housing and the core must be uniform and without voids. The strength of the bond shall be greater than the tearing strength of the polymer.
6. All bushings shall be suitable for heavily polluted atmosphere and minimum creepage distance shall be taken as 31mm per KV.
7. Clamps and fittings shall be of hot dip galvanised/stainless steel.
8. No arcing horns shall be provided on the bushings.
9. RIP Bushing shall be specially packed to avoid any damage during transit and suitable for long storage, with non-returnable packing wooden boxes with hinged type cover. Without any gap between wooden planks. Packing Box opening cover with nails/screws type packing arrangement shall not be acceptable. Bushing oil end portion shall be fitted with metal housing with positive dry air pressure and a suitable pressure monitoring device shall be fitted on the metal housing during storage to avoid direct contact with moisture with epoxy. Alternatively, oil filled metal housing with suitable arrangement for taking care oil expansion due to temperature variations shall also be acceptable. Manufacturer shall submit drawing/documents of packing for approval during detail engineering. Detail method for storage of bushing including accessories shall be brought out in the instruction manual.
10. Tan delta measurement at variable frequency (in the range of 20 Hz to 350 Hz) shall be carried out on each condenser type bushing (OIP & RIP) at Transformer manufacturing works as routine test before despatch and the result shall be compared at site during commissioning to verify the healthiness of the bushing.
11. Tan delta value of RIP condenser bushing shall be 0.005 (max.) in the temperature range of 20°C to 90°C. The measured Tan Delta value at site should not exceed by .001 w.r.t. factory results (measured at approx. similar temperature conditions) and in no case shall exceed 0.005 during warrantee period. No temperature correction factor is applicable.



BHARAT HEAVY ELECTRICALS LIMITED, JHANSI
TRANSFORMER ENGINEERING DEPARTMENT
ANNEXURE-RIP BUSHING

(C) For 52 KV 3150 Amp Bushing		
Sl No.	Electrical Parameter	Details
1.	Highest System Voltage	52 KV
2.	Rated Current	3150 Amp (Min.)
3.	Rated Frequency	50 Hz
4.	1 Minute AC withstand Test (Dry)	105 KVrms
5.	1 Minute AC withstand Test (Wet)	95 KVrms
6.	Basic Insulation Level	250 KVp
7.	Rated Short Circuit Current	50 KA
8.	Rated Short -Circuit Current Duration	3 Sec
9.	Cantilever Test Load	As per IEC 60137
10.	Minimum Creepage Distance	1612 mm (Min.)
11.	Tan-Delta in the range of 20°C to 90°C (Without any temperature correction)	0.005 (Max.)
12.	Reference BHEL Drawing	BCE-3-1069



BHARAT HEAVY ELECTRICALS LIMITED, JHANSI
TRANSFORMER ENGINEERING DEPARTMENT
ANNEXURE-RIP BUSHING

1. Bushings shall be robust and designed for adequate cantilever strength to meet the requirement of seismic condition, substation layout and movement along with the spare Transformer with bushing erected and provided with proper support from one foundation to another foundation within the substation area. The electrical and mechanical characteristics of bushings shall be in accordance with IS 2099 & IEC: 60137/DIN 42530. All details of the bushing shall be submitted for approval and design review.
2. Bushing for voltage above 52 kV shall be RIP (Resin Impregnated paper) / RIS (Resin Impregnated Synthetic) / RIF (Resin Impregnated Fiberglass) condenser type with composite polymer insulator (housing).
3. RIP type bushing shall be provided with tap for capacitance and tan delta test. Test taps relying on pressure contacts against the outer earth layer of the bushing is not acceptable.
4. Bushings of identical rating shall be interchangeable to optimise the requirement of spares.
5. Polymer/composite insulator shall be seamless sheath of a silicone rubber compound. The housing & weather sheds should have silicon content of minimum 30% by weight. It should protect the bushing against environmental influences, external pollution and humidity. The interface between the housing and the core must be uniform and without voids. The strength of the bond shall be greater than the tearing strength of the polymer.
6. All bushings shall be suitable for heavily polluted atmosphere and minimum creepage distance shall be taken as 31mm per KV.
7. Clamps and fittings shall be of hot dip galvanised/stainless steel.
8. No arcing horns shall be provided on the bushings.
9. RIP Bushing shall be specially packed to avoid any damage during transit and suitable for long storage, with non-returnable packing wooden boxes with hinged type cover. Without any gap between wooden planks. Packing Box opening cover with nails/screws type packing arrangement shall not be acceptable. Bushing oil end portion shall be fitted with metal housing with positive dry air pressure and a suitable pressure monitoring device shall be fitted on the metal housing during storage to avoid direct contact with moisture with epoxy. Alternatively, oil filled metal housing with suitable arrangement for taking care oil expansion due to temperature variations shall also be acceptable. Manufacturer shall submit drawing/documents of packing for approval during detail engineering. Detail method for storage of bushing including accessories shall be brought out in the instruction manual.
10. Tan delta measurement at variable frequency (in the range of 20 Hz to 350 Hz) shall be carried out on each condenser type bushing (OIP & RIP) at Transformer manufacturing works as routine test before despatch and the result shall be compared at site during commissioning to verify the healthiness of the bushing.
11. Tan delta value of RIP condenser bushing shall be 0.005 (max.) in the temperature range of 20°C to 90°C. The measured Tan Delta value at site should not exceed by .001 w.r.t. factory results (measured at approx. similar temperature conditions) and in no case shall exceed 0.005 during warrantee period. No temperature correction factor is applicable.



BHARAT HEAVY ELECTRICALS LIMITED, JHANSI
TRANSFORMER ENGINEERING DEPARTMENT
ANNEXURE-RIP BUSHING

TECHNICAL DETAILS OF RIP BUSHING

(A) For 245 KV 1250 Amp Bushing		
Sl No.	Electrical Parameter	Details
1.	Highest System Voltage	245 KV
2.	Rated Current	1250 Amp (Min.)
3.	Rated Frequency	50 Hz
4.	1 Minute AC withstand Test (Dry)	505 KVrms
5.	1 Minute AC withstand Test (Wet)	460 KVrms
6.	Basic Insulation Level	1050 KVp
7.	Switching Impulse Voltage	850 KVp
8.	Rated Short Circuit Current	50 KA
9.	Rated Short -Circuit Current Duration	3 Sec
10.	Cantilever Test Load	As per IEC 60137
11.	Minimum Creepage Distance	7595 mm (Min.)
12.	Tan-Delta in the range of 20°C to 90°C (Without any temperature correction)	0.005 (Max.)
13.	Reference BHEL Drawing	BCE-3-1217



BHARAT HEAVY ELECTRICALS LIMITED, JHANSI
TRANSFORMER ENGINEERING DEPARTMENT
ANNEXURE-RIP BUSHING

(B) For 145 KV 1250 Amp Bushing		
Sl No.	Electrical Parameter	Details
1.	Highest System Voltage	145 KV
2.	Rated Current	1250 Amp (Min.)
3.	Rated Frequency	50 Hz
4.	1 Minute AC withstand Test (Dry)	305 KVrms
5.	1 Minute AC withstand Test (Wet)	275 KVrms
6.	Basic Insulation Level	650 KVp
7.	Rated Short Circuit Current	50 KA
8.	Rated Short –Circuit Current Duration	3 Sec
9.	Cantilever Test Load	As per IEC 60137
10.	Minimum Creepage Distance	4495 mm (Min.)
11.	Tan-Delta in the range of 20°C to 90°C (Without any temperature correction)	0.005 (Max.)
12.	Reference BHEL Drawing	BCE-3-1216

DECLARATION OF LOCAL CONTENT AS PER PREFERENCE TO MII ORDER-2017

Date:

To,
Bharat Heavy Electricals Limited
Khailar, Jhansi, U.P.-284120

Subject: - Certification regarding Local Content

Reference: Tender enquiry NO.....

Name of items:

Dear Sir,

We hereby certify that the quoted items offered by us against above Enquiry is having local content of

Further, to certify that the local content % certified above is in line with definition of Local content given in point no. 2 Of Public Procurement (Preference to Make in India), Order 2017 and we qualify as (Class-I/Class- II/Non-Local supplier — fill in one which is applicable) local supplier.

We further confirm that details of location at which the local value addition is made will be at.....

I hereby declare that the details furnished above are true and correct to the best of my knowledge and belief and I undertake to inform you of any changes therein, immediately. In case any of the above information is found to be false or untrue or misleading or misrepresenting, I am aware that I may be held liable for it.

Regards,

(Sign and seal of supplier)

S No.	Components & operations	Characteristics	Class	Type of check	Sampling	Reference/ Standard	Acceptance norms	Format of record	Applicable codes			Remarks
									M	C	N	

2.4	Bushings (RIP)
-----	----------------

MANUFACTURERS TEST
 CERTIFICATE SHALL BE
 SUBMITTED FOR REVIEW
 (THESE ITEMS SHALL BE AS PER
 CONTRACT / DESIGN) As per
 Applicable

IS/PS	IS/PS	P	V	V
-------	-------	---	---	---

Legends: CLASSTYPE OF CHECK AGENCY SCOPE OF AGENCY

A: CRITICAL
 B: MAJOR
 C: MINOR

V: VISUAL
 I: MEASUREMENT
 T: TEST

M: MANUFACTURER / SUB CONTRACTOR
 C: CONT. / NOMINATED INSPECTION AGENCY
 N: CUSTOMER

P: PERFORMER
 V: VERIFICATION
 W: WITNESS

CHP: CUSTOMER HOLD POINT



Bharat Heavy Electricals Limited

)A Govt of India Undertaking(

MM Department, Sub post Office: BHEL Jhansi 284120

Tel: 5102412554,9486369271

e-mail: arjun.singh@bhel.in; rahulkumar.r@bhel.in

INTEGRITY PACT

Between Bharat Heavy Electricals Ltd. (BHEL), a company registered under the Companies Act 1956 and having its registered office at "BHEL House", Siri Fort, New Delhi - 110049 (India) hereinafter referred to as "The Principal", which expression unless repugnant to the context or meaning hereof shall include its successors or assigns of the ONE PART

and

_____ (description of the party along with address), hereinafter referred to as "The Bidder/ Contractor" which expression unless repugnant to the context or meaning hereof shall include its successors or assigns of the OTHER PART

Preamble

The Principal intends to award, under laid-down organizational procedures, contract/s for _____ E1830003 _____

_____ (hereinafter referred to as "Contract"). The Principal values full compliance with all relevant laws of the land, rules and regulations, and the principles of economic use of resources, and of fairness and transparency in its relations with its Bidder(s)/ Contractor(s).

In order to achieve these goals, the Principal will appoint panel of Independent External Monitor(s) (IEMs), who will monitor the tender process and the execution of the contract for compliance with the principles mentioned above.

Section 1- Commitments of the Principal

1.1 The Principal commits itself to take all measures necessary to prevent corruption and to observe the following principles: -

1.1.1 No employee of the Principal, personally or through family members, will in connection with the tender for, or the execution of a contract, demand, take a promise for or accept, for self or third person, any material or immaterial benefit which the person is not legally entitled to.

1.1.2 The Principal will, during the tender process treat all Bidder(s) with equity and reason. The Principal will in particular, before and during the tender process, provide to all Bidder(s) the same information and will not provide to any Bidder(s) confidential/ additional information through which the Bidder(s) could obtain an advantage in relation to the tender process or the contract execution.

1.1.3 The Principal will exclude from the process all known prejudiced persons.

1.2 If the Principal obtains information on the conduct of any of its employees which is a penal offence under the Indian Penal Code 1860 and Prevention of Corruption Act 1988 or any other statutory penal enactment, or if there be a substantive suspicion in this regard, the Principal will inform its Vigilance Office and in addition can initiate disciplinary actions.

Section 2 - Commitments of the Bidder(s)/ Contractor(s)

Signature of Supplier with seal and Date

Page 1 | 6

2.1 The Bidder(s)/ Contractor(s) commit himself to take all measures necessary to prevent corruption. The Bidder(s)/ Contractor(s) commits himself to observe the following principles during participation in the tender process and during the contract execution.

2.1.1 The Bidder(s)/ Contractor(s) will not, directly or through any other person or firm, offer, promise or give to the Principal or to any of the Principal's employees involved in the tender process or the execution of the contract or to any third person any material, immaterial or any other benefit which he/she is not legally entitled to, in order to obtain in exchange any advantage of any kind whatsoever during the tender process or during the execution of the contract.

2.1.2 The Bidder(s)/ Contractor(s) will not enter with other Bidder(s) into any illegal or undisclosed agreement or understanding, whether formal or informal. This applies in particular to prices, specifications, certifications, subsidiary contracts, submission or non-submission of bids or any other actions to restrict competitiveness or to introduce cartelization in the bidding process.

2.1.3 The Bidder(s)/ Contractor(s) will not commit any penal offence under the relevant Indian Penal Code (IPC) and Prevention of Corruption Act; further the Bidder(s)/ Contractor(s) will not use improperly, for purposes of competition or personal gain, or pass on to others, any information or document provided by the Principal as part of the business relationship, regarding plans, technical proposals and business details, including information contained or transmitted electronically.

2.1.4 Foreign Bidder(s)/ Contractor(s) shall disclose the name and address of agents and representatives in India and Indian Bidder(s)/ Contractor(s) to disclose their foreign principals or associates. The Bidder(s)/ Contractor(s) will, when presenting his bid, disclose any and all payments he has made, and is committed to or intends to make to agents, brokers or any other intermediaries in connection with the award of the contract.

2.2 The Bidder(s)/ Contractor(s) will not instigate third persons to commit offences outlined above or be an accessory to such offences.

2.3 The Bidder(s)/ Contractor(s) shall not approach the Courts while representing the matters to IEMs and shall await their decision in the matter.

Section 3 - Disqualification from tender process and exclusion from future contracts

If the Bidder(s)/ Contractor(s), before award or during execution has committed a transgression through a violation of Section 2 above, or acts in any other manner such as to put his reliability or credibility in question, the Principal is entitled to disqualify the Bidder(s)/ Contractor(s) from the tender process, terminate the contract, if already awarded, exclude from future business dealings and/ or take action as per the separate "Guidelines on Banning of Business dealings with Suppliers/ Contractors", framed by the Principal.

Section 4 - Compensation for Damages

4.1 If the Principal has disqualified the Bidder (s) from the tender process before award / order acceptance according to Section 3, the Principal is entitled to demand and recover the damages equivalent to Earnest Money Deposit/ Bid Security.

4.2 If the Principal is entitled to terminate the Contract according to Section 3, or terminates the Contract in application of Section 3 above, the Bidder(s)/ Contractor (s) transgression through a violation of Section

2 above shall be construed breach of contract and the Principal shall be entitled to demand and recover from the Contractor an amount equal to 5% of the contract value or the amount equivalent to Security Deposit/ Performance Bank Guarantee, whichever is higher, as damages, in addition to and without prejudice to its right to demand and recover compensation for any other loss or damages specified elsewhere in the contract.

Section 5 - Previous Transgression

5.1 The Bidder declares that no previous transgressions occurred in the last 3 (three) years with any other company in any country conforming to the anti-corruption approach or with any other Public Sector Enterprise in India that could justify his exclusion from the tender process.

5.2 If the Bidder makes incorrect statement on this subject, he can be disqualified from the tender process or the contract, if already awarded, can be terminated for such reason or action can be taken as per the separate "Guidelines on Banning of Business dealings with Suppliers/ Contractors", framed by the Principal.

Section 6 - Equal treatment of all Bidder (s)/ Contractor (s) / Sub-contractor (s)

6.1 The Principal will enter into Integrity Pacts with identical conditions as this Integrity Pact with all Bidders and Contractors.

6.2 In case of Sub-contracting, the Principal Contractor shall take the responsibility of the adoption of Integrity Pact by the Sub-contractor(s) and ensure that all Sub-contractors also sign the Integrity Pact.

6.3 The Principal will disqualify from the tender process all Bidders who do not sign this Integrity Pact or violate its provisions.

Section 7 - Criminal Charges against violating Bidders/ Contractors /Subcontractors

If the Principal obtains knowledge of conduct of a Bidder, Contractor or Subcontractor, or of an employee or a representative or an associate of a Bidder, Contractor or Subcontractor which constitutes corruption, or if the Principal has substantive suspicion in this regard, the Principal will inform the Vigilance Office.

Section 8 -Independent External Monitor(s)

8.1 The Principal appoints competent and credible panel of Independent External Monitor (s) (IEMs) for this Integrity Pact. The task of the IEMs is to review independently and objectively, whether and to what extent the parties comply with the obligations under this Integrity Pact.

8.2 The IEMs are not subject to instructions by the representatives of the parties and performs his functions neutrally and independently. He reports to the CMD, BHEL.

8.3 The IEMs shall be provided access to all documents/ records pertaining to the Contract, for which a complaint or issue is raised before them as and when warranted. However, the documents/records/information having National Security implications and those documents which have been classified as Secret/Top Secret are not to be disclosed.

8.4 The Principal will provide to the IEMs sufficient information about all meetings among the parties related to the Contract provided such meetings could have an impact on the contractual relations

between the Principal and the Contractor. The parties offer to the IEMs the option to participate in such meetings.

8.5 The advisory role of IEMs is envisaged as that of a friend, philosopher and guide. The advice of IEMs would not be legally binding and it is restricted to resolving issues raised by a Bidder regarding any aspect of the tender which allegedly restricts competition or bias towards some Bidders. At the same time, it must be understood that IEMs are not consultants to the Management. Their role is independent in nature and the advice once tendered would not be subject to review at the request of the organization.

8.6 For ensuring the desired transparency and objectivity in dealing with the complaints arising out of any tendering process or during execution of Contract, the matter should be examined by the full panel of IEMs jointly, who would look into the records, conduct an investigation, and submit their joint recommendations to the Management.

8.7 The IEMs would examine all complaints received by them and give their recommendations/ views to the CMD, BHEL at the earliest. They may also send their report directly to the CVO, in case of suspicion of serious irregularities requiring legal/ administrative action. Only in case of very serious issue having a specific, verifiable Vigilance angle, the matter should be reported directly to the Commission. IEMs will tender their advice on the complaints within 30 days.

8.8 The CMD, BHEL shall decide the compensation to be paid to the IEMs and its terms and conditions.

8.9 IEMs should examine the process integrity, they are not expected to concern themselves with fixing of responsibility of officers. Complaints alleging mala fide on the part of any officer of the Principal should be looked into by the CVO of the Principal.

8.10 If the IEMs have reported to the CMD, BHEL, a substantiated suspicion of an offence under relevant Indian Penal Code / Prevention of Corruption Act, and the CMD, BHEL has not, within reasonable time, taken visible action to proceed against such offence or reported it to the Vigilance Office, the IEMs may also transmit this information directly to the Central Vigilance Commissioner, Government of India.

8.11 After award of work, the IEMs shall look into any issue relating to execution of Contract, if specifically raised before them. As an illustrative example, if a Contractor who has been awarded the Contract, during the execution of Contract, raises issue of delayed payment etc. before the IEMs, the same shall be examined by the panel of IEMs. Issues like warranty/ guarantee etc. shall be outside the purview of IEMs.

8.12 However, the IEMs may suggest systemic improvements to the management of the Principal, if considered necessary, to bring about transparency, equity and fairness in the system of procurement.

8.13 The word 'Monitor' would include both singular and plural.

Section 9 - Pact Duration

9.1 This Integrity Pact shall be operative from the date this Integrity Pact is signed by both the parties till the final completion of contract for successful Bidder, and for all other Bidders 6 months after the Contract has been awarded. Any violation of the same would entail disqualification of the bidders and exclusion from future business dealings.

9.2 If any claim is made/ lodged during currency of this Integrity Pact, the same shall be binding and continue to be valid despite the lapse of this Pact as specified above, unless it is discharged/ determined by the CMD, BHEL.

Section 10 - Other Provisions

10.1 This Integrity Pact is subject to Indian Laws and exclusive jurisdiction shall be of the competent Courts as indicated in the Tender or Contract, as the case may be.

10.2 Changes and supplements as well as termination notices need to be made in writing.

10.3 If the Bidder(s)/ Contractor (s) is a partnership or a consortium or a joint venture, this Integrity Pact shall be signed by all partners of the partnership or joint venture or all consortium members.

10.4 Should one or several provisions of this Integrity Pact turn out to be invalid, the remainder of this Integrity Pact remains valid. In this case, the parties will strive to come to an agreement to their original intentions.

10.5 Only those bidders / contractors who have entered into this Integrity Pact with the Principal would be competent to participate in the bidding. In other words, entering into this Integrity Pact would be a preliminary qualification.

10.6 In the event of any dispute between the Principal and Bidder(s)/ Contractor(s) relating to the Contract, in case, both the parties are agreeable, they may try to settle dispute through Mediation before the panel of IEMs in a time bound manner. In case, the dispute remains unresolved even after mediation by the panel of IEMs, either party may take further action as the terms & conditions of the Contract. The fees/expenses on dispute resolution through mediation shall be shared by both the parties. Further, the mediation proceedings shall be confidential in nature and the parties shall keep confidential all matters relating to the mediation proceedings including any settlement agreement arrived at between the parties as outcome of mediation. Any views expressed, suggestions, admissions or proposals etc. made by either party in the course of mediation shall not be relied upon or introduced as evidence in any further arbitral or judicial proceedings, whether or not such proceedings relate to the dispute that is the subject of mediation proceedings. Neither of the parties shall present IEMs as witness in any Alternative Dispute Resolution or judicial proceedings in respect of the dispute that was subject of mediation.

 (Signature)
 RAHUL KUMAR
 (राहुल कुमार)
 (Signature)
 06/06/23
 (Date)
 MM Department, Jhansi
 B.H.E.L., Jhansi
 For & On behalf of the Principal
 (Office Seal)

 For & On behalf of the Bidder/ Contractor
 (Office Seal)

Place JHANSI

Date 06/06/23

Witness: Prabhat
 (Name & Address) Prabhat
(MM-BHEL JHANSI)

Witness: _____
 (Name & Address) _____

Clause on IP in the tender

Integrity Pact (IP)

- (a) IP is a tool to ensure that activities and transactions between the Company and its Bidders/ Contractors are handled in a fair, transparent and corruption free manner. Following Independent External Monitors (IEMs) on the present panel have been appointed by BHEL with the approval of CVC to oversee implementation of IP in BHEL.

SI	IEM	Email
1.	Shri Otem Dai, IAS (Retd.)	iem1@bhel.in
2.	Shri Bishwamitra Pandey, IRAS (Retd.)	iem2@bhel.in
3.	Shri Mukesh Mittal, IRS (Retd.)	iem3@bhel.in

- (b) The IP as enclosed with the tender is to be submitted (duly signed by authorized signatory) along with techno-commercial bid (Part-I, in case of two/ three part bid). Only those bidders who have entered into such an IP with BHEL would be competent to participate in the bidding. In other words, entering into this Pact would be a preliminary qualification.
- (c) Please refer Section-8 of IP for Role and Responsibilities of IEMs. In case of any complaint arising out of the tendering process, the matter may be referred to any of the above IEM(s). All correspondence with the IEMs shall be done through email only.

Note:

No routine correspondence shall be addressed to the IEM (phone/ post/ email) regarding the clarifications, time extensions or any other administrative queries, etc on the tender issued. All such clarification/ issues shall be addressed directly to the tender issuing (procurement) department's officials whose contact details are provided below.

Details of contact person(s):

(1)
Name: _____
Deptt: _____
Address: _____
Phone: (Landline/ Mobile) _____

Email: _____
Fax: _____

(2)
Name: _____
Deptt: _____
Address: _____
Phone: (Landline/ Mobile) _____

Email: _____
Fax: _____

6901-3-BCEB ON DRG.

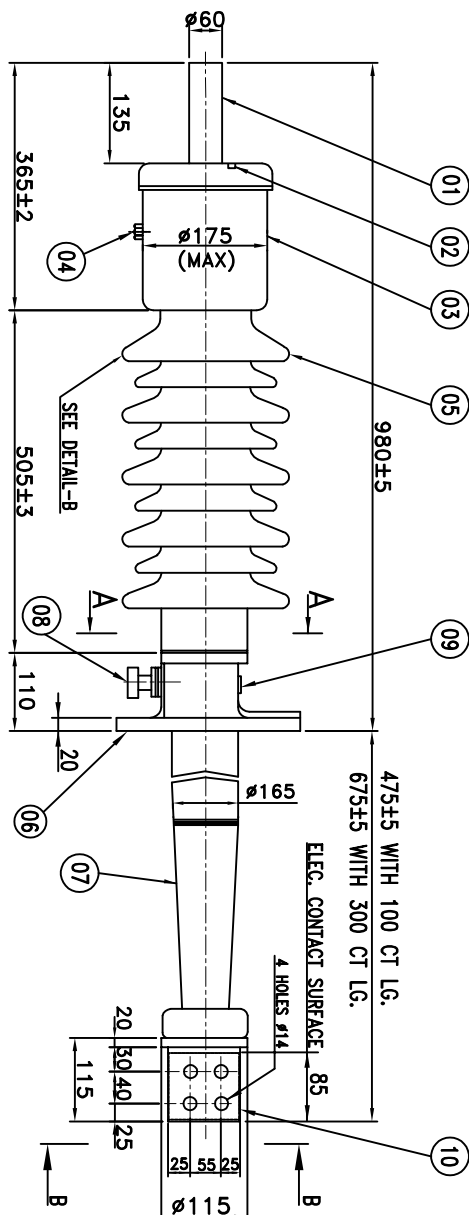

QTY.	IT.	DESCRIPTION	MATERIAL
1	01	TOP TERMINAL	COPPER
2	02	FILLING PLUG	S. STEEL
1	03	TOP CAP	AL. ALLOY
1	04	OIL LEVEL GAUGE	TOUGHENED GLASS
1	05	TOP PORCELAIN FLANGE	PORCELAIN
1	06	MOUNTING FLANGE	AL. ALLOY
1	07	BOTTOM PORCELAIN FLANGE	PORCELAIN
1	08	TEST TAP	AL. ALLOY
1	09	RATING PLATE	AL. ANODISED
1	10	BOTTOM TERMINAL	COPPER FORGING

TOTAL WEIGHT IN KG.		
ITEM	2000 A	3150 A
100 CT	91	103
300 CT	99	112

TECHNICAL DETAILS

RATED VOLTAGE : 52KV
 RATED CURRENT : 2000A/3150A
 1 MIN. 50Hz DRY & WET WITH STAND : 105 KV
 LIGHTNING IMPULSE 1.2/50 u SEC. FULL WAVE : 250 KVP
 STANDARD APPLICABLE : IS:2099/IEC-137
 MINIMUM CREEPAGE DISTANCE : 1300 mm
 ALTITUDE : < 1000 m
 ANGLE OF MOUNTING : 30° MAX.
 APPLICATION : OIL-AIR

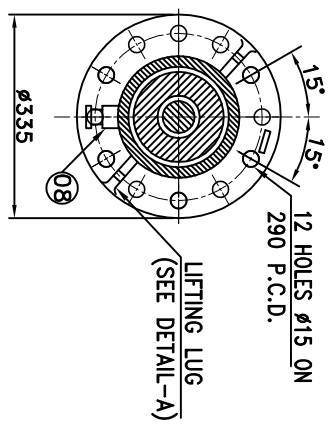

SECTION-AA

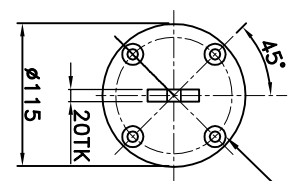

SECTION-BB

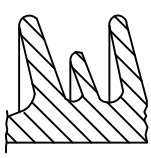

DETAIL-B
(ALT. SHED PROFILE)

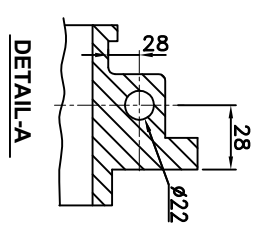

DETAIL-A

INVENTORY NO. SING. AND DATE REF. DRG. NO.

REV. DATE ALTERED PRADEEP
 09 21.10.2021 CHECKED BRM/SEK
 ZONE DRG. REVIEW & MODIFIED.

TYPE OF PRODUCT		OR		NAME OF CUSTOMER/PROJECT	
BHARAT HEAVY ELECTRICALS LTD.		BHO PAL		BHO PAL	
DEPT	BCE	CODE OF TO. DIM.	C/M/F	SCALE	WEIGHT (KG)
CODE	421			NTS	SEE TABLE
TITLE	52KV OIP CONDENSER BUSHING				CARD CODE
DRN.	N.K.WANI	SING.	Sd/-	DATE	NO.OF
CHD.	HOTI TAL		Sd/-	14.11.86	VAR.
APPD.	R.K.AGRWAL		Sd/-	14.11.86	
REF. TO ASSY. DRG.	05380101012				ITEM NO.
DRAWING NO.	BCE-3-1069				REV.
SHEET NO.	01	NO. OF SHEETS	01		09

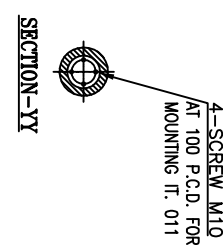
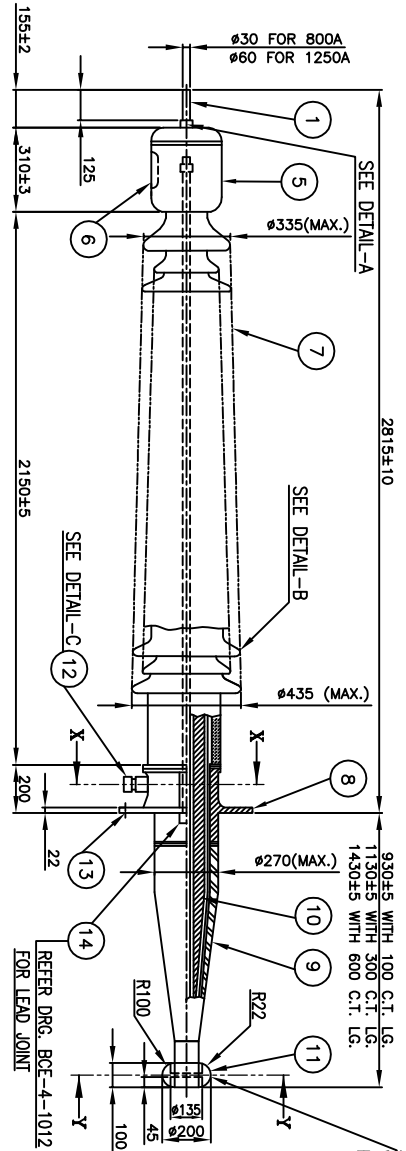

QTY./ITEM	DESCRIPTION	MATERIAL
1	TOP TERMINAL	BRASS
1	LEAD ASSY	COPPER
1	'O' SEAL	RUBBER
2	FILLING PLUG	S.STEEL
1	TOP CAP	AL. ALLOY
1	OIL LEVEL GAUGE	GLASS
1	PORCELAIN INSULATOR TOP	BROWN GLAZED
1	MOUNTING FLANGE	AL. ALLOY
1	BOTTOM PORCELAIN	BROWN GLAZED
1	CONDENSER BUSHING	KRAFT PAPER
1	STRESS SHIELD	AL. ALLOY
1	TEST TAP	STEEL/NYLON
1	RATING PLATE	AL. ALLOY
1	LEAD CONNECTOR	COPPER
1	RUBBER SEAL	NITRILE RUBBER
1	PULL THROUGH CONNECTOR	COPPER
1	CORONA SHIELD	AL ALLOY

TECHNICAL DETAILS :-

1. RATED VOLTAGE : 245KV
2. RATED CURRENT : 800/1250 AMP
3. 1 MIN.50 HZ DRY & WET WITHSTAND VOLTAGE : 460 KV
4. LIGHTNING IMPULSE : 1050 KVP
5. RATED FREQUENCY : 50 HZ.
6. STANDARD APPLICABLE : IS 2099/ IEC:137
7. MIN. CREEPAGE DISTANCE : 7600 MM
8. APPROX. OIL QTY. : 35 LITRES
9. INSTALLATION ANGLE FROM VERTICAL : 30° MAX
10. TRANSPORTATION ANGLE HORIZONTAL : 15°
11. APPROX. WEIGHT. : 380 KG
12. ARCING HORN (ADJ. GAP 800-1450) : OPTIONAL
13. TYPE : OUTDOOR OIL IMMERSSED BUSHING

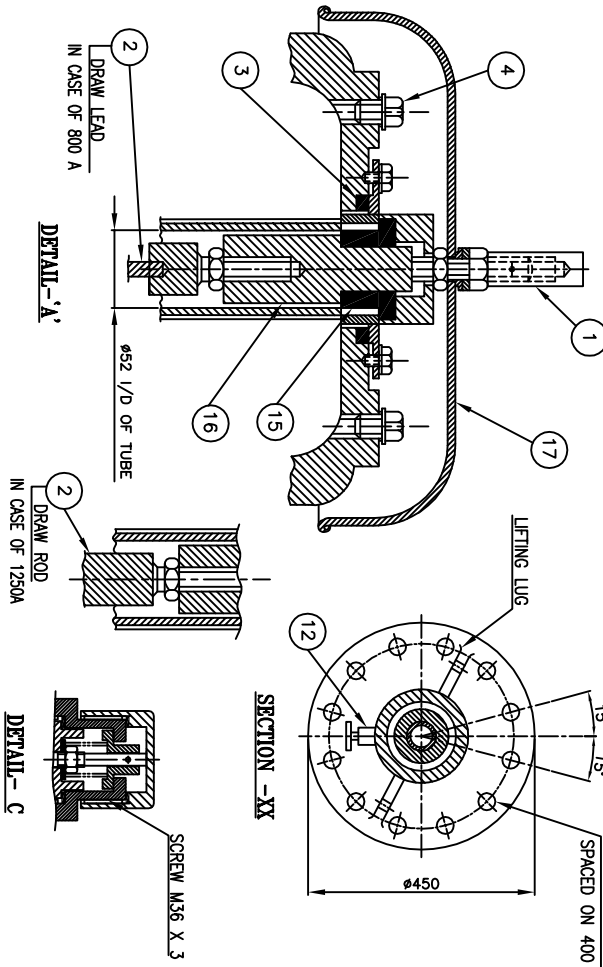

REV.	DATE	ALTERED	PRADDEEP	REV.	DATE	ALTERED	B.R.M.
04	22.09.20	CHECKED	BRM/SEK	03	09.02.07	CHECKED	A.DHAMALIA
ZONE DRG. REDRAWN & UPDATED.				ZONE 100 CTL. ADDED AND DRG. COMPUTERISED.			

TYPE OF PRODUCT OR NAME OF CUSTOMER/PROJECT		SCALE		WEIGHT (KG)		NAME		DATE	
BHARAT HEAVY ELECTRICALS LTD. BHOVAL		1:20		380 (APPROX)		SING.		DATE	
DEPT. BCE	CODE OF DIM. 4.21	SCALE 1:20	WEIGHT 380 (APPROX)	NAME B.R.M.	SING. Sd/-	DATE 27.07.92	NO.OF VAR.		
				NAME H.L./M.M.	SING. Sd/-	DATE 28.07.92	NO.OF VAR.		
				NAME R.K.A.	SING. Sd/-	DATE 28.07.92	NO.OF VAR.		
				REF. TO ASSY. DRG. 05380101002			ITEM NO.		
				REF. TO ASSY. DRG. 05380101002			NO. OF ITEMS		

REV.	DATE	ALTERED	PRADDEEP	REV.	DATE	ALTERED	B.R.M.
04	22.09.20	CHECKED	BRM/SEK	03	09.02.07	CHECKED	A.DHAMALIA
ZONE DRG. REDRAWN & UPDATED.				ZONE 100 CTL. ADDED AND DRG. COMPUTERISED.			

DEPT.	CODE OF DIM.	SCALE	WEIGHT (KG)	NAME	SING.	DATE	NO.OF
BCE	4.21	1:20	380 (APPROX)	B.R.M.	Sd/-	27.07.92	VAR.
				H.L./M.M.	Sd/-	28.07.92	
				R.K.A.	Sd/-	28.07.92	
				REF. TO ASSY. DRG. 05380101002			ITEM NO.
				REF. TO ASSY. DRG. 05380101002			NO. OF ITEMS

REV.	NO. OF SHEETS	NO. OF SHEETS
04	01	01

