

CAUTION: The information on this document is the property of BHARAT HEAVY ELECTRICALS LTD. It must not be used directly or indirectly in any way detrimental to the interest of the company.

REV	DATE	ALTERED
01		APPROVED

ALL DIMENSIONS ARE IN MILLIMETRES

NOTES :-

- DESIGN PRESSURE : 48.4 Kg/Cm² (g)
- DESIGN TEMPERATURE : 568° C

EDGE PREPARATION
AS PER DRG.NO:
3-80-300-19825
FIG-X d₁ = 665

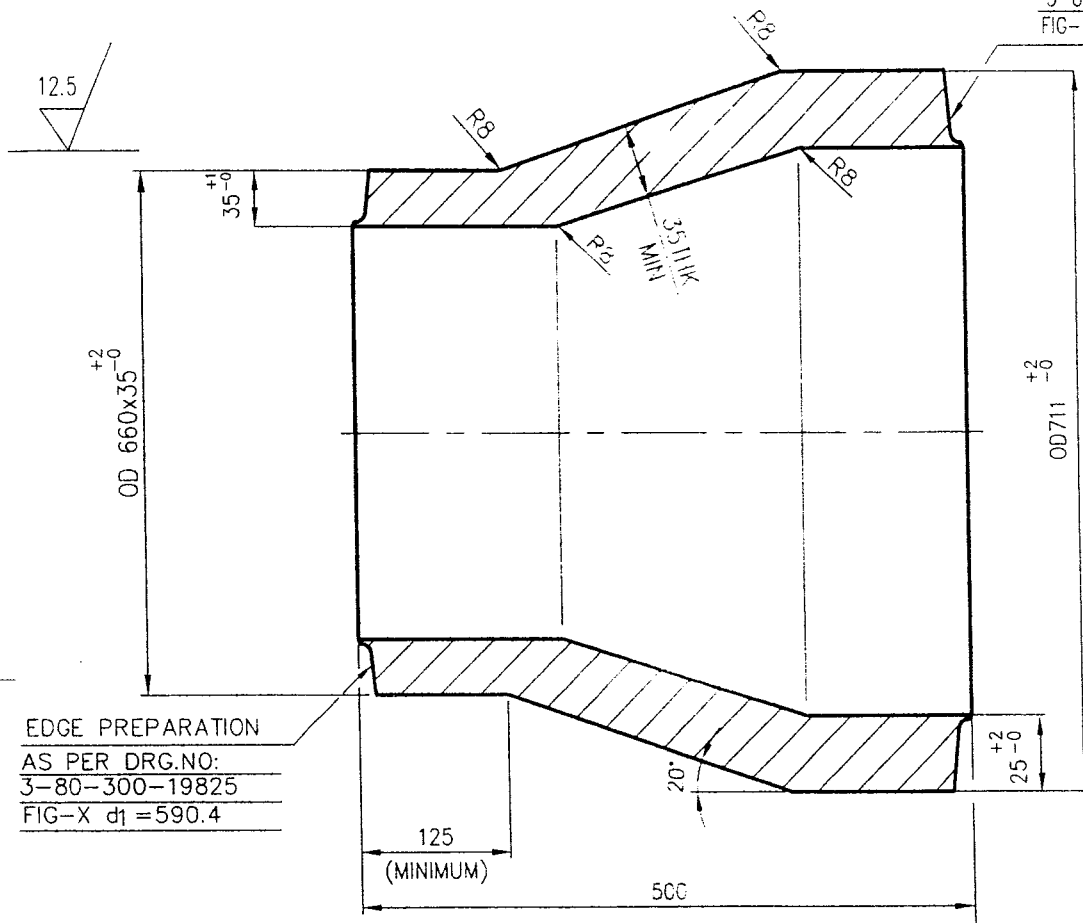

EDGE PREPARATION
AS PER DRG.NO:
3-80-300-19825
FIG-X d₁ = 590.4

	REDUCER L=500 OD711x25/OD660x35	92 117 438 0000 SA182F91	A	180 000
VAR NO.	DESCRIPTION	MATL. CODE	A	UNIT
		MATL. SPECN.	C	DI
				UNIT.WT.(Kg)
				QTY.



BHARAT HEAVY ELECTRICALS LIMITED
PIPING CENTRE
CHENNAI 600 017

DRN	NAME	SIGN	DATE	NO. OF VAR
CHD	M. CHAKKARA		30.12.06	
APPD	A. AMALRAJ		30.12.06	
	M. SRINIVASAN		30.12.06	

DEPT	GRADE OF UN.TOL.DIM	SCALE	WEIGHT (KG)	BHEL PO REF.NO:	ITEM NO.	NO. OF ITEMS
CODE	C / M / F	N.T.S	130.000			
TITLE			CARD CODE	DRAWING NO.	REV	
MACHINED REDUCER (OD711x25/OD660x35)			U 01	4-80-310-63827	00	

CAUTION: The information on this document is the property of BHARAT HEAVY ELECTRICALS LTD. It must not be used directly or indirectly in any way detrimental to the interest of the company.

REV	DATE	ALTERED
01		APPROVED

ALL DIMENSIONS ARE IN MILLIMETRES



NOTES :-

- DESIGN PRESSURE : 48.4 kg/cm² (g)
- DESIGN TEMPERATURE : 568° C

EDGE PREPARATION
AS PER DRG.NO:
3-80-300-19825
FIG-X d₁ = 710

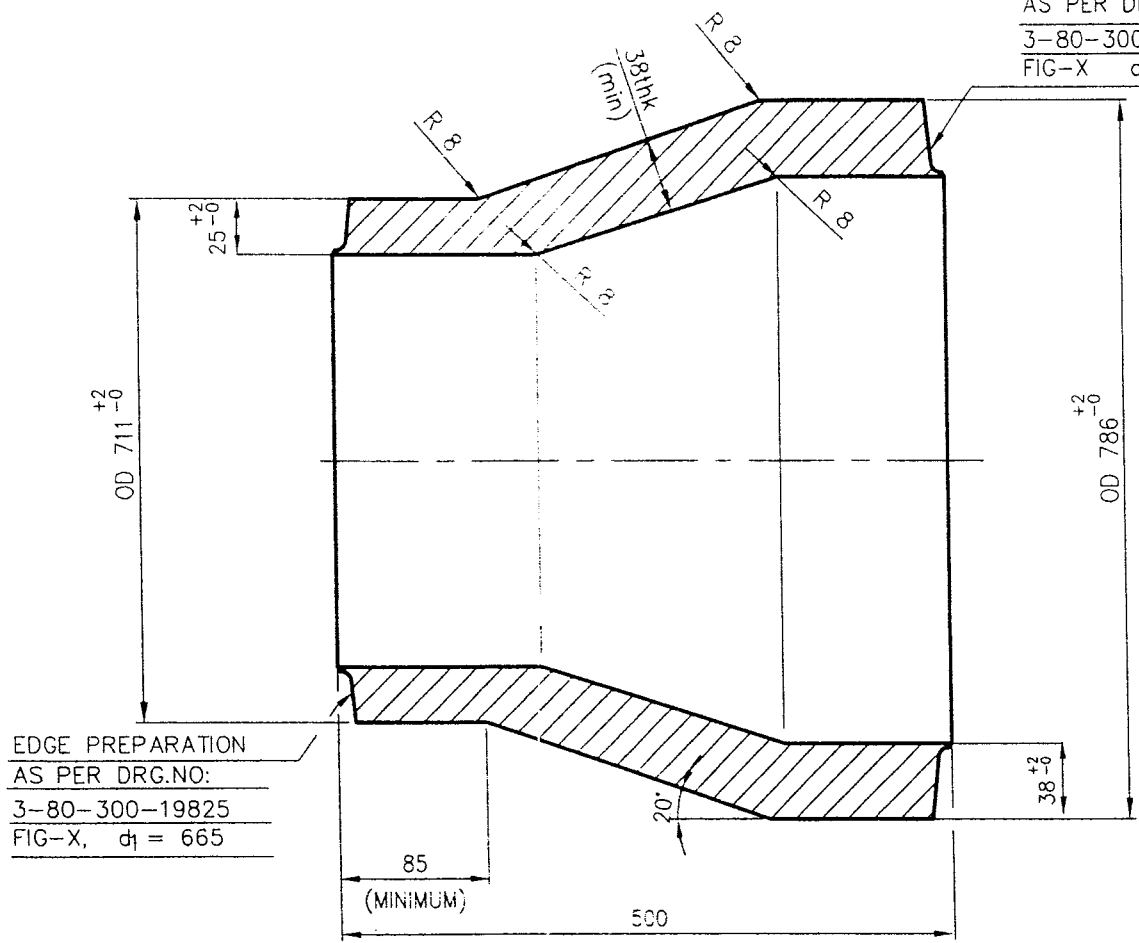

EDGE PREPARATION
AS PER DRG.NO:
3-80-300-19825
FIG-X, d₁ = 665

	REDUCER L=500 OD 786x38/OD 711x25	92 117 440 0000 SA 182 F91	A	300 000
VAR NO.	DESCRIPTION	MATL. CODE	A	UNIT
		MATL. SPECN.	C	QTY.

		BHARAT HEAVY ELECTRICALS LIMITED PIPING CENTRE CHENNAI- 600 017		DRN	NAME	SIGN	DATE	NO. OF VAR
				CHD	A. AMALRAJ		30.12.06	
				APPD	M. SRINIVASAN		30.12.06	
DEPT	GRADE OF UNTOLEDIM	SCALE	WEIGHT (KG)	BHEL PO REF.NO:			ITEM NO.	NO. OF ITEMS
CODE	C / M / F	N.T.S	300.000					
TITLE				CARD CODE	DRAWING NO.			REV
MACHINED REDUCER (OD786x38/OD711x25)				U 01	4-80-311-63825			00

CAUTION: The information on this document is the property of BHARAT HEAVY ELECTRICALS LTD. It must not be used directly or indirectly in any way detrimental to the interest of the company.

REV	DATE	ALTERED
01		APPROVED

ALL DIMENSIONS ARE IN MILLIMETRES

NOTES :-

- DESIGN PRESSURE : 48.4 Kg/Cm² (g)
- DESIGN TEMPERATURE : 568° C

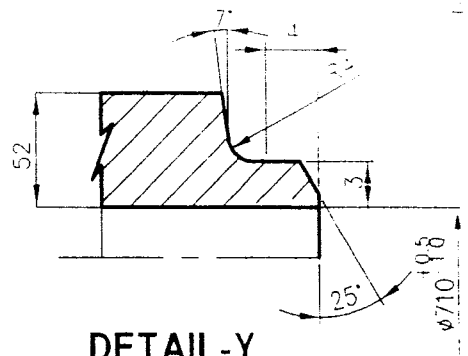

DETAIL-Y

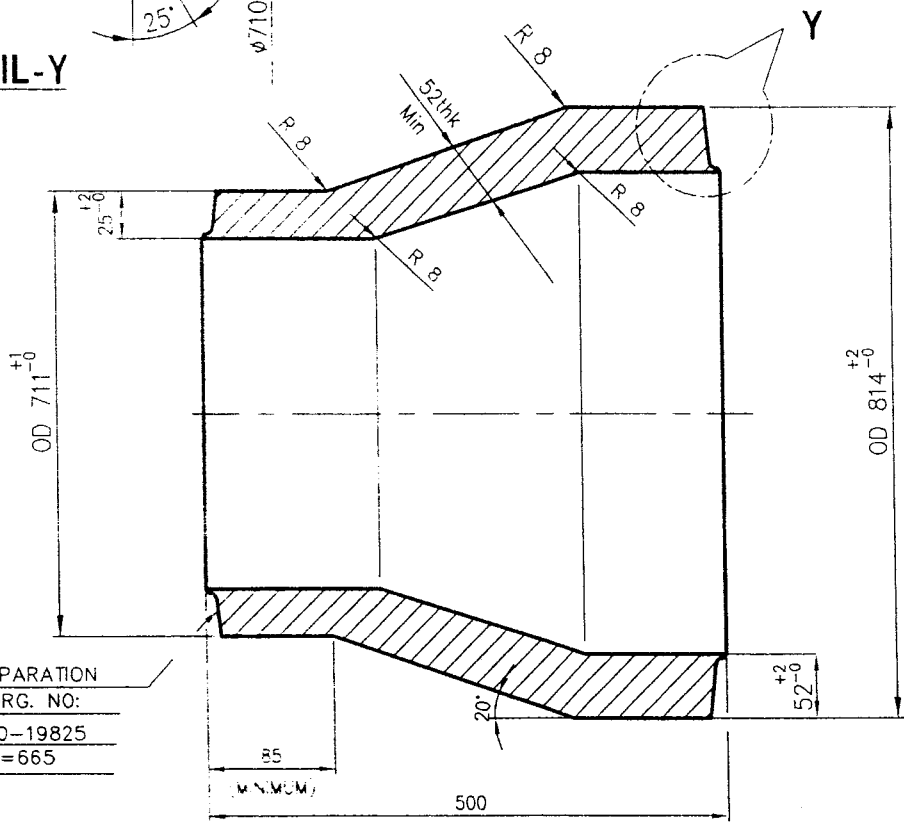

EDGE PREPARATION
AS PER DRG. NO:
3-80-300-19825
FIG-X, d1 = 665

	REDUCER L=500 OD 814x52/OD711x25	92 117 441 0000 SA 182 F91	A	390 000
VAR NO.	DESCRIPTION	MATL. CODE	A	UNIT
		MATL. SPECN.	C	DI
				UNIT.WT.(Kg)
				QTY.

 BHARAT HEAVY ELECTRICALS LIMITED PIPING CENTRE CHENNAI - 600 047		DRN	NAME	SIGN	DATE	NO. OF VAR
		CHD	M. CHAKKARA		30.12.06	
		APPD	A. AMALRAJ		30.12.06	
			M. SRINIVASAN		30.12.06	
DEPT	GRADE OF UNTOLED. DIM	SCALE	WEIGHT (KG).	BHEL PO REF. NO:		ITEM NO.
CODE	C / M / F	N.T.S	390.000			NO. OF ITEMS
TITLE			CARD CODE	DRAWING NO.		REV
MACHINED REDUCER (OD814x52 / OD 711x25)			U 01	4-80-311-63824		00

CAUTION: The information on this document is the property of BHARAT HEAVY ELECTRICALS LIMITED. It must not be used directly or indirectly in any way detrimental to the interest of the company.

REV	DATE	ALTERED
01		APPROVED

ALL DIMENSIONS ARE IN MILLIMETRES

12.5

NOTES :-

- DESIGN PRESSURE 45.4 Kg/Cm² (g)
- DESIGN TEMPERATURE 583° C

EDGE PREPARATION
AS PER DRG NO:
3-80-300-19825
FIG-X, d1=800

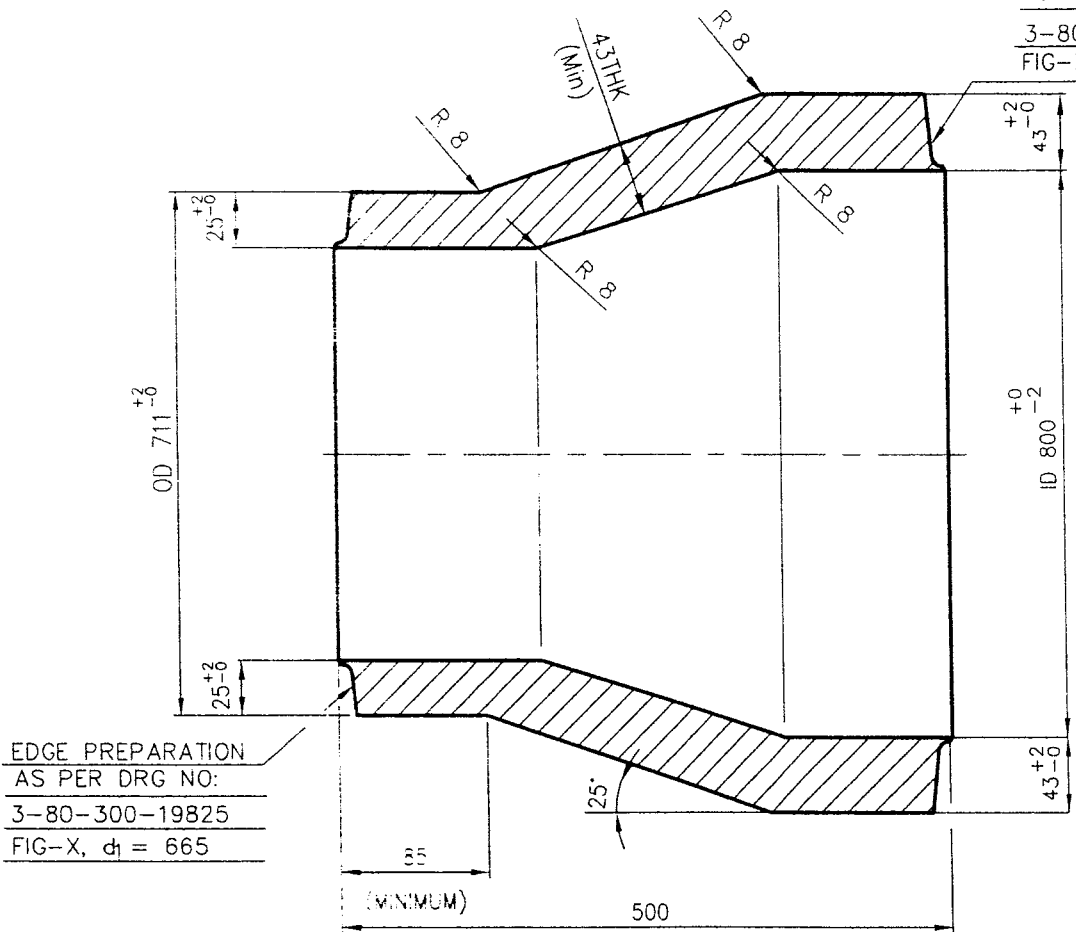

EDGE PREPARATION
AS PER DRG NO:
3-80-300-19825
FIG-X, d1 = 665

ITEM NO	DESCRIPTION	STD	MATCHING PIECE L=500	92 117 443 0000	A	UNIT	450	000
			ID800max x thk43min/ CD 711X25	SA 182 F91				
NO	DESCRIPTION	STD	MATL. CODE		A	UNIT	UNIT.WT.(Kg)	
			MATL. SPECN.				DI	QTY.

		BHARAT HEAVY ELECTRICALS LIMITED PIPING CENTRE CHENNAI - 600 017		DRN	M. CHAKKARA	SIGN		DATE	30.12.06	NO. OF VAR	
DEPT	GRADE OF UNTOL. DIM	SCALE	WEIGHT (KG).	CHD	A. AMALRAJ				30.12.06		
CODE	C / M / F	N.T.S	450.000	APPD	M. SRINIVASAN				30.12.06		
TITLE				CARD CODE	DRAWING NO.				REV		
MATCHING PIECE (ID800maxXthk43min/OD711X25)				U 01	4-80-310-63822				00		

CAUTION: The information on this document is the property of BHARAT HEAVY ELECTRICALS LTD. It must not be used directly or indirectly in any way detrimental to the interest of the company.

REV	DATE	ALTERED
		APPROVED

ALL DIMENSIONS ARE IN MILLIMETRES

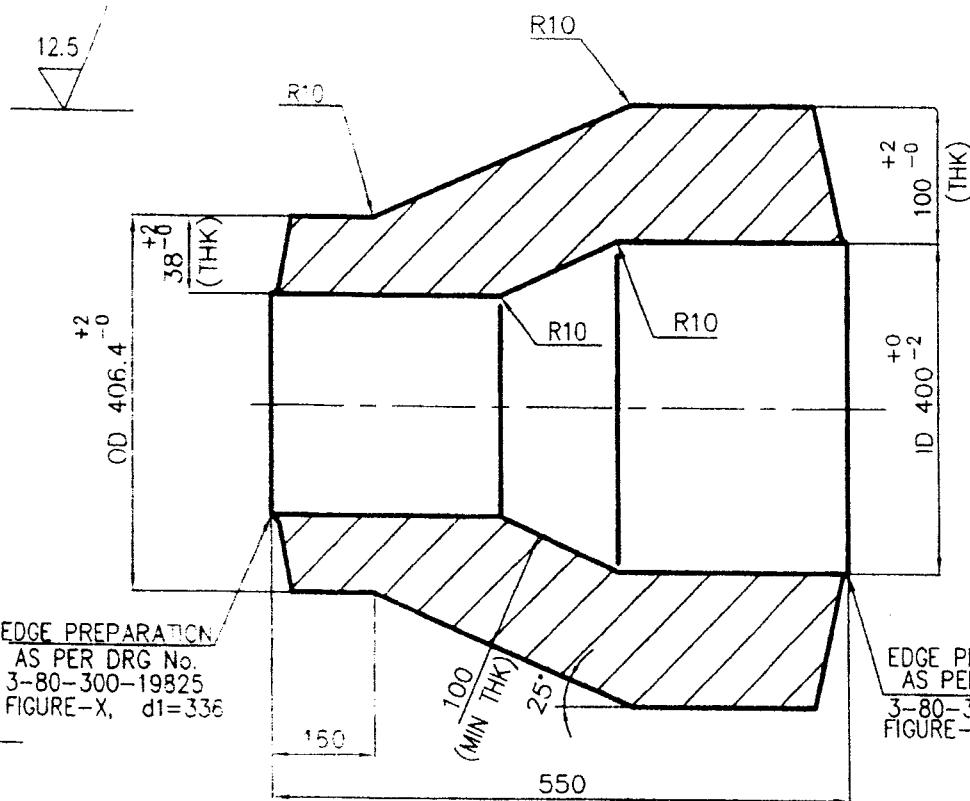

EDGE PREPARATION
AS PER DRG No.
3-80-300-19825
FIGURE-X, d1=336

EDGE PREPARATION
AS PER DRG No.
3-80-300-19825
FIGURE-X, d1=400

STANDARD		MATCHING PIECE ID 400 Max x Thk 100 min OD406.4 x 38 L=550		92 517 942 0000		A		343 000		
VAR NO.	DESCRIPTION	SID	MATL. CODE	A	UNIT	UNIT.WT.(Kg)				
			MATL. SPECN.	C	DI	QTY.				
BHARAT HEAVY ELECTRICALS LIMITED PIPING CENTRE CHENNAI 600 017		NAME	SIGN	DATE	NO. OF VAR					
DEPT	GRADE OF UNIT/DIM	SCALE	WEIGHT (KG).	BHEL PO REF.NO:	ITEM NO.	NO. OF ITEMS				
CODE	C / M / F	N.T.S	343.000							
TITLE MATCHING PIECE (ID400 max x Thk 100 min/OD406.4x38)		CARD CODE U 01	DRAWING NO. 4-80-301-62568			REV 00				

CAUTION: The information on this document is the property of BHARAT HEAVY ELECTRICALS LTD. It must not be used directly or indirectly in any way detrimental to the interest of the company.

REV	DATE	ALTERED
01		APPROVED

ALL DIMENSIONS ARE IN MILLIMETRES

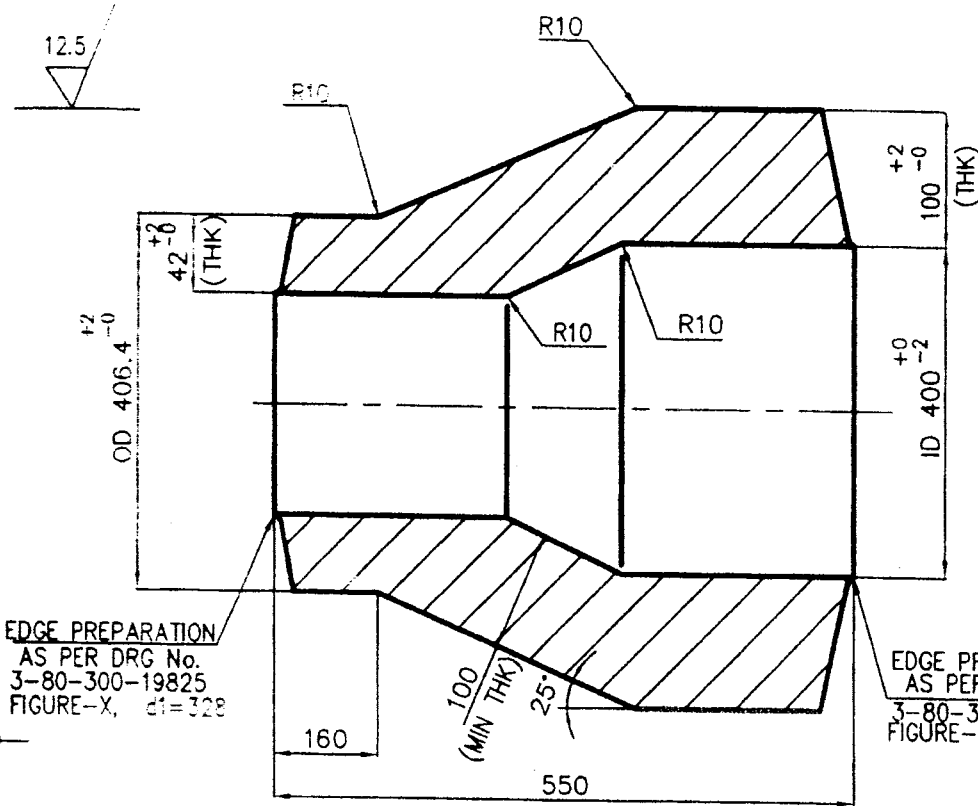

EDGE PREPARATION
AS PER DRG No.
3-80-300-19825
FIGURE-X, $d_1=400$

EDGE PREPARATION
AS PER DRG No.
3-80-300-19825
FIGURE-X, $d_1=400$

VAR NO.	DESCRIPTION	STD	92 527 127 0000	A	343 000
			SA 182 F91		
			MATL. CODE	A C	UNIT
			MATL. SPECN.		
					QTY.

STANDARD

	BHARAT HEAVY ELECTRICALS LIMITED PIPING CENTRE CHENNAI 600 017			NAME	SIGN	DATE	NO. OF VAR
	DRN	A. PRIYA	<i>A. Priya</i>	05-11-05			
	CHD	M.C.SEKARAN	<i>M. C. Sekaran</i>	05-11-05			
	APPD	A. VELAYUTHAM	<i>A. Velayutham</i>	05-11-05			

DEPT	GRADE OF TOL DIM	SCALE	WEIGHT (KG).	BHEL PO REF.NO:	ITEM NO.	NO. OF ITEMS
CODE	C / M / F	N.T.S	343.000			

TITLE	CARD CODE	DRAWING NO.	REV
MATCHING PIECE (343 max x Thk 100 min/OD406.4x42)	U 01	4-80-301-60825	00

FIRST ANGLE PROJECTION (ALL DIMENSIONS IN MILLIMETRES)

52861-001 (1) B

NOTES:-

- 01. APPLICABLE FOR P91 MATERIAL
- 02. FOR OD MISMATCHING, REF. FIGURE - Xa.
- 03. $\alpha = 6^\circ$ FOR WALL THICKNESS ≤ 30 mm
- 04. $\alpha = 10^\circ$ FOR WALL THICKNESS > 30 mm

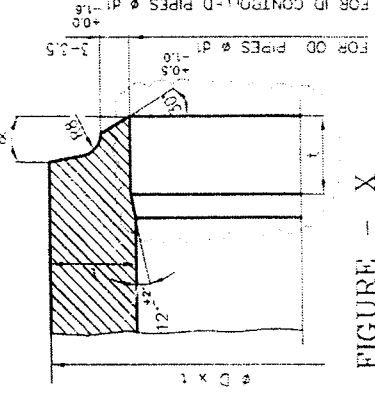

FIGURE - X

MATCHING EDGE PREPARATION FOR MISMATCH (i.e. OD1 - OD2 > 8mm.) APPLICABLE FOR ELBOWS/FITTINGS OF P91 MATERIALS

NOTES:-

- 01. OD OF STRAIGHT TO BE PHYSICALLY MEASURED/VERIFIED.
- 02. $\alpha = 6^\circ$ FOR WALL THICKNESS ≤ 30 mm
- 03. $\alpha = 10^\circ$ FOR WALL THICKNESS > 30 mm

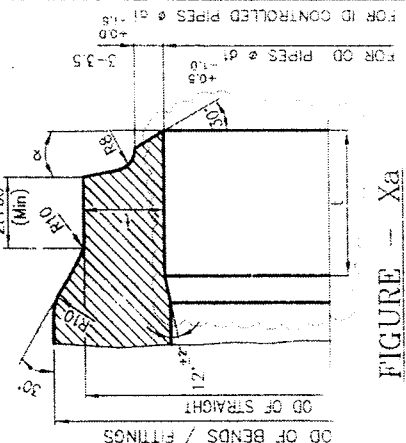
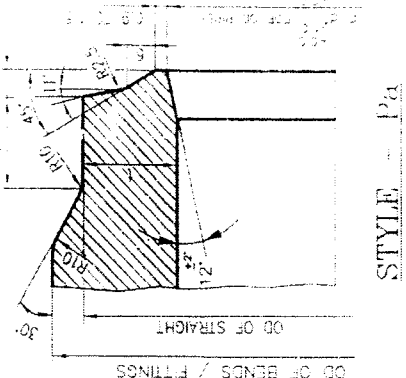

FIGURE - Xa

MATCHING EDGE PREPARATION FOR MISMATCH (i.e. OD1 - OD2 > 8mm.) APPLICABLE FOR ELBOWS/FITTINGS OTHER THAN P91 MATERIALS

NOTES:-

- 01. OD OF STRAIGHT TO BE PHYSICALLY MEASURED/VERIFIED.
- 02. WHEN t < 6.5, S + t = 1.5 Min. & t < 6.5 - 6.5 Min. WHERE t = THK OF CONE/FLUT (STRAIGHT)



STYLE - Pa

MATCHING EDGE PREPARATION FOR MISMATCH (i.e. OD1 - OD2 > 8mm.) APPLICABLE FOR ELBOWS/FITTINGS OTHER THAN P91 MATERIALS

NOTES:-

- 01. OD OF STRAIGHT TO BE PHYSICALLY MEASURED/VERIFIED.
- 02. WHEN t < 6.5, S + t = 1.5 Min. & t < 6.5 - 6.5 Min. WHERE t = THK OF CONE/FLUT (STRAIGHT)

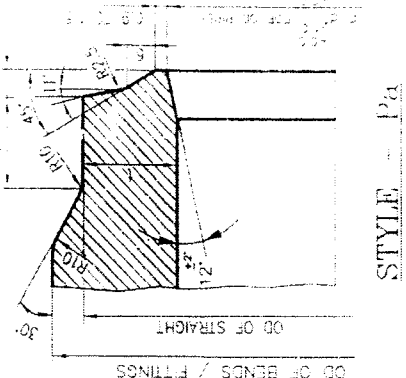

STYLE - Pa

MATCHING EDGE PREPARATION FOR MISMATCH OD DIAMETRICALLY GREATER THAN 8 mm (i.e. OD1 - OD2 > 8mm.) APPLICABLE FOR ELBOWS OTHER THAN P91 MATERIALS

NOTES:-

- 01. OD = OUTSIDE DIA OF CONNECTING PIPE (STRAIGHT) TO BE PHYSICALLY MEASURED/VERIFIED.
- 02. t = THK OF CONN. PIPE (STRAIGHT)

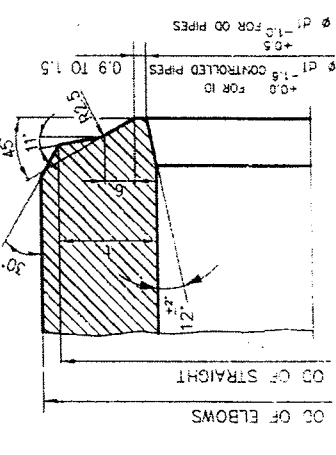

FIGURE - Z

GENERAL NOTES:-

- 01. THE MINIMUM THICKNESS AT WELD END SHALL NOT BE LESS THAN a) 0.875 TIMES t NOM. FOR OD PIPES. b) t MIN. FOR ID CONTROLLED PIPES.
- 02. t NOM & t MIN SHALL BE AS PER SPECIFIED PIPE SIZE.

NOTES FOR WELDING:-

- 01. WELD REINFORCEMENT TO BE FLUSH GROUND AND MERGED WITH PARENT METAL WITHOUT ANY FILL WELDS.

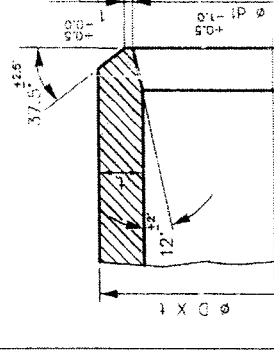

STYLE - D

NOTES:-

- 01. USE WHEN t < 14.2 mm.

STANDARD

TYPE OF PRODUCT OR NAME OF CUSTOMER/PROJECT	BHARAT HEAVY ELECTRICALS LTD. PIPING CENTRE, CHENNAI		NAME	SRN	DATE	NO OF ITEMS
DEPT	GRADE OF UN TOL DIM	C/M/F	DRN	CHK	APPD	WGT (KG)
CODE	C/M/F	SCALE	DRN	CHK	APPD	WGT (KG)
TITLE	EDGE PREPARATION DETAILS		DRN	CHK	APPD	WGT (KG)
CARD CODE	U 01	DRAWING No	DRN	CHK	APPD	WGT (KG)
REV	3	80 300	DRN	CHK	APPD	WGT (KG)
		19825	DRN	CHK	APPD	WGT (KG)
		01	DRN	CHK	APPD	WGT (KG)