

**BHARAT HEAVY ELECTRICALS LIMITED**

[A Government of India Undertaking]

Ramachandrapuram, Hyderabad, 502032, A.P. India
Phone 040-23184526, 23182322 FAX:040-23021910, 1954**भारत हेवी इलेक्ट्रिकल्स लिमिटेड**

(भारत सरकार का उपक्रम)

रामचन्द्रपुरम, हैदराबाद, 502032 आंध्र प्रदेश, भारत

RFQ NO :

PURCHASE DEPARTMENT**ENQUIRY****क्रय विभाग**

जांच (ई मेल : tenderbox@bhellhyd.co.in)

SHEET:1

OF :13

HY17001 C REV.NO.0	Phone 091-40-23184526 091-40-23182322	FAX : 091-40-23021910 091-40-23021954	PURCHASE DEPARTMENT			
-----------------------	--	--	----------------------------	--	--	--

GSTIN:		Enq/Collective No :E5A1Z35637	Enq.Dt. : 20.04.2026	No.Of Items :*	DUE Dt. OF QUOTN. : 04.05.2026
--------	--	-------------------------------	----------------------	----------------	--------------------------------

Office Copy

Please submit your lowest quotation in sealed cover superscribed with Enquiry No./Collective No.(RFQ No) and due date subject to our terms and conditions attached ,for the materials mentioned below.Your offer has to reach us onor before due date by 11.00 Hours (IST) and will be opened at 14.00 Hours.(IST).If our Enquiry No./Collective No.(RFQ No) and tender due date are not super scribed on the tender cover , your offer shall be summarily rejected. Incomplete offers and late offers will not be considered.

SL NO	Purchase Req.no	item no	Material Code, HSN No.	Drg no - Ver , Rev & Spec - Ver , Rev,Spec-Var	Description	Unit	Qty	Delivery Date	Schedule Qty
1	8000135637	60	HE9712844250 73269099	41750103637-01,00,HE51546,,NA	HEMIHEAD FORGING	EA	6.000	01.05.2027	1.000
2	8000135637	10	73269099					01.05.2027	1.000
3	8000135637	20	73269099					01.05.2027	1.000
4	8000135637	30	73269099					01.05.2027	1.000
5	8000135637	40	73269099					01.05.2027	1.000
6	8000135637	50	73269099					01.05.2027	1.000
7	8000135637	70	HE9712844269 73269099	41750103637-02,00,HE51546,,NA	TEST COUPON FOR HEMIHEAD	EA	6.000	01.05.2027	1.000
8	8000135637	120	73269099					01.05.2027	1.000
9	8000135637	110	73269099					01.05.2027	1.000
10	8000135637	100	73269099					01.05.2027	1.000

TEST CERTIFICATE REQD:
GUARANTEE REQ :
SAMPLE REQD :
BID TYPE : TWO PART

For and on-behalf of
Bharat Heavy Electricals Limited.

Arief Ahmed Choudhury
BHEL Hyderabad/HEF Purchase

**BHARAT HEAVY ELECTRICALS LIMITED**

[A Government of India Undertaking]

Ramachandrapuram, Hyderabad, 502032, A.P. India
Phone 040-23184526, 23182322 FAX:040-23021910, 1954**भारत हेवी इलेक्ट्रिकल्स लिमिटेड**

(भारत सरकार का उपक्रम)

रामचन्द्रपुरम, हैदराबाद, 502032 आंध्र प्रदेश, भारत

RFQ NO :

PURCHASE DEPARTMENT**ENQUIRY****क्रय विभाग**

जांच (ई मेल : tenderbox@bhellhyd.co.in)

SHEET:2
OF :13HY17001 C
REV.NO.0Phone 091-40-23184526
091-40-23182322FAX : 091-40-23021910
091-40-23021954**PURCHASE DEPARTMENT**

GSTIN:

Enq/Collective No :E5A1Z35637

Enq.Dt. : 20.04.2026

No.Of Items :*

DUE Dt. OF QUOTN. : 04.05.2026

Office Copy

Please submit your lowest quotation in sealed cover superscribed with Enquiry No./Collective No.(RFQ No) and due date subject to our terms and conditions attached ,for the materials mentioned below.Your offer has to reach us onor before due date by 11.00 Hours (IST) and will be opened at 14.00 Hours.(IST).If our Enquiry No./Collective No.(RFQ No) and tender due date are not super scribed on the tender cover , your offer shall be summarily rejected. Incomplete offers and late offers will not be considered.

SL NO	Purchase Req.no	item no	Material Code, HSN No.	Drg no - Ver , Rev & Spec - Ver , Rev,Spec-Var	Description	Unit	Qty	Delivery Date	Schedule Qty
11	8000140744	10	73269099					10.11.2026	1.000
12	8000140744	20	73269099					10.11.2026	1.000
13	8000140744	50	73269099					15.12.2026	1.000
14	8000140744	60	73269099					15.12.2026	1.000
15	8000140747	10	73269099					10.01.2027	1.000
16	8000140747	20	73269099					10.01.2027	1.000
17	8000140747	50	73269099					10.03.2027	1.000
18	8000140747	60	73269099					10.03.2027	1.000
19	8000140750	50	73269099					10.05.2027	1.000
20	8000140750	60	73269099					10.05.2027	1.000

TEST CERTIFICATE REQD:
GUARANTEE REQ :
SAMPLE REQD :
BID TYPE : TWO PART

For and on-behalf of
Bharat Heavy Electricals Limited.

Arief Ahmed Choudhury
BHEL Hyderabad/HEF Purchase

**BHARAT HEAVY ELECTRICALS LIMITED**

[A Government of India Undertaking]

Ramachandrapuram, Hyderabad, 502032, A.P. India
Phone 040-23184526, 23182322 FAX:040-23021910, 1954**भारत हेवी इलेक्ट्रिकल्स लिमिटेड**

(भारत सरकार का उपक्रम)

रामचन्द्रपुरम, हैदराबाद, 502032 आंध्र प्रदेश, भारत

RFQ NO :

PURCHASE DEPARTMENT**ENQUIRY****क्रय विभाग**

जांच (ई मेल : tenderbox@bhellhyd.co.in)

SHEET:3
OF :13HY17001 C
REV.NO.0Phone 091-40-23184526
091-40-23182322FAX : 091-40-23021910
091-40-23021954**PURCHASE DEPARTMENT**

GSTIN:

Enq/Collective No :E5A1Z35637

Enq.Dt. : 20.04.2026

No.Of Items :*

DUE Dt. OF QUOTN : 04.05.2026

Office Copy

Please submit your lowest quotation in sealed cover superscribed with Enquiry No./Collective No.(RFQ No) and due date subject to our terms and conditions attached ,for the materials mentioned below.Your offer has to reach us onor before due date by 11.00 Hours (IST) and will be opened at 14.00 Hours.(IST).If our Enquiry No./Collective No.(RFQ No) and tender due date are not super scribed on the tender cover , your offer shall be summarily rejected. Incomplete offers and late offers will not be considered.

SL NO	Purchase Req.no	item no	Material Code, HSN No.	Drg no - Ver , Rev & Spec - Ver , Rev,Spec-Var	Description	Unit	Qty	Delivery Date	Schedule Qty
21	8000135637	90	73269099					01.05.2027	1.000
22	8000140750	20	73269099					10.04.2027	1.000
23	8000140750	40	HE9712844307 73269099	41750103667-02,00,HE51546,,NA	TEST COUPON FOR HEMIHEAD FORGING	EA	14.000	10.04.2027	1.000
24	8000137265	40	73269099					01.11.2026	1.000
25	8000137265	30	73269099					01.11.2026	1.000
26	8000140744	30	73269099					10.11.2026	1.000
27	8000140744	40	73269099					10.11.2026	1.000
28	8000140744	80	73269099					15.12.2026	1.000
29	8000140744	70	73269099					15.12.2026	1.000
30	8000140747	80	73269099					10.03.2027	1.000

TEST CERTIFICATE REQD:
GUARANTEE REQ :
SAMPLE REQD :
BID TYPE : TWO PART

For and on-behalf of
Bharat Heavy Electricals Limited.

Arief Ahmed Choudhury
BHEL Hyderabad/HEF Purchase

**BHARAT HEAVY ELECTRICALS LIMITED**

[A Government of India Undertaking]

Ramachandrapuram, Hyderabad, 502032, A.P. India
Phone 040-23184526, 23182322 FAX:040-23021910, 1954**भारत हेवी इलेक्ट्रिकल्स लिमिटेड**

(भारत सरकार का उपक्रम)

रामचन्द्रपुरम, हैदराबाद, 502032 आंध्र प्रदेश, भारत

RFQ NO :

PURCHASE DEPARTMENT**ENQUIRY****क्रय विभाग**

जांच (ई मेल : tenderbox@bhellhyd.co.in)

SHEET:4
OF :13HY17001 C
REV.NO.0Phone 091-40-23184526
091-40-23182322FAX : 091-40-23021910
091-40-23021954**PURCHASE DEPARTMENT**

GSTIN:

Enq/Collective No :E5A1Z35637

Enq.Dt. : 20.04.2026

No.Of Items :*

DUE Dt. OF QUOTN. : 04.05.2026

Office Copy

Please submit your lowest quotation in sealed cover superscribed with Enquiry No./Collective No.(RFQ No) and due date subject to our terms and conditions attached ,for the materials mentioned below.Your offer has to reach us onor before due date by 11.00 Hours (IST) and will be opened at 14.00 Hours.(IST).If our Enquiry No./Collective No.(RFQ No) and tender due date are not super scribed on the tender cover , your offer shall be summarily rejected. Incomplete offers and late offers will not be considered.

SL NO	Purchase Req.no	item no	Material Code, HSN No.	Drg no - Ver , Rev & Spec - Ver , Rev,Spec-Var	Description	Unit	Qty	Delivery Date	Schedule Qty
31	8000140747	70	73269099					10.03.2027	1.000
32	8000135637	80	73269099					01.05.2027	1.000
33	8000140747	40	73269099					10.01.2027	1.000
34	8000140747	30	73269099					10.01.2027	1.000
35	8000140750	80	73269099					10.05.2027	1.000
36	8000140750	70	73269099					10.05.2027	1.000
37	8000140750	30	73269099					10.04.2027	1.000
38	8000139483	10	HE9712844277 73269099	41750103663-01,00,HE51546,,NA	HEMIHEAD FORGING	EA	42.000	10.04.2027	1.000
39	8000137261	60	73269099					01.11.2026	1.000
40	8000137261	50	73269099					01.11.2026	1.000

TEST CERTIFICATE REQD:
GUARANTEE REQ :
SAMPLE REQD :
BID TYPE : TWO PART

For and on-behalf of
Bharat Heavy Electricals Limited.

Arief Ahmed Choudhury
BHEL Hyderabad/HEF Purchase

**BHARAT HEAVY ELECTRICALS LIMITED**

[A Government of India Undertaking]

Ramachandrapuram, Hyderabad, 502032, A.P. India
Phone 040-23184526, 23182322 FAX:040-23021910, 1954**भारत हेवी इलेक्ट्रिकल्स लिमिटेड**

(भारत सरकार का उपक्रम)

रामचन्द्रपुरम, हैदराबाद, 502032 आंध्र प्रदेश, भारत

RFQ NO :

PURCHASE DEPARTMENT**ENQUIRY****क्रय विभाग**

जांच (ई मेल : tenderbox@bhellhyd.co.in)

SHEET:5
OF :13HY17001 C
REV.NO.0Phone 091-40-23184526
091-40-23182322FAX : 091-40-23021910
091-40-23021954**PURCHASE DEPARTMENT**

GSTIN:

Enq/Collective No :E5A1Z35637

Enq.Dt. : 20.04.2026

No.Of Items :*

DUE Dt. OF QUOTN. : 04.05.2026

Office Copy

Please submit your lowest quotation in sealed cover superscribed with Enquiry No./Collective No.(RFQ No) and due date subject to our terms and conditions attached ,for the materials mentioned below.Your offer has to reach us onor before due date by 11.00 Hours (IST) and will be opened at 14.00 Hours.(IST).If our Enquiry No./Collective No.(RFQ No) and tender due date are not super scribed on the tender cover , your offer shall be summarily rejected. Incomplete offers and late offers will not be considered.

SL NO	Purchase Req.no	item no	Material Code, HSN No.	Drg no - Ver , Rev & Spec - Ver , Rev,Spec-Var	Description	Unit	Qty	Delivery Date	Schedule Qty
41	8000137261	40	73269099					01.11.2026	1.000
42	8000137261	30	73269099					01.11.2026	1.000
43	8000137261	20	73269099					01.11.2026	1.000
44	8000137261	10	73269099					01.11.2026	1.000
45	8000139208	60	73269099					10.11.2026	1.000
46	8000139208	50	73269099					10.11.2026	1.000
47	8000139208	40	73269099					10.11.2026	1.000
48	8000139208	30	73269099					10.11.2026	1.000
49	8000139208	20	73269099					10.11.2026	1.000
50	8000139208	10	73269099					10.11.2026	1.000

TEST CERTIFICATE REQD:
GUARANTEE REQ :
SAMPLE REQD :
BID TYPE : TWO PART

For and on-behalf of
Bharat Heavy Electricals Limited.

Arief Ahmed Choudhury
BHEL Hyderabad/HEF Purchase

**BHARAT HEAVY ELECTRICALS LIMITED**

[A Government of India Undertaking]

Ramachandrapuram, Hyderabad, 502032, A.P. India
Phone 040-23184526, 23182322 FAX:040-23021910, 1954**भारत हेवी इलेक्ट्रिकल्स लिमिटेड**

(भारत सरकार का उपक्रम)

रामचन्द्रपुरम, हैदराबाद, 502032 आंध्र प्रदेश, भारत

RFQ NO :

PURCHASE DEPARTMENT**ENQUIRY****क्रय विभाग**

जांच (ई मेल : tenderbox@bhellhyd.co.in)

SHEET:6
OF :13HY17001 C
REV.NO.0Phone 091-40-23184526
091-40-23182322FAX : 091-40-23021910
091-40-23021954**PURCHASE DEPARTMENT**

GSTIN:

Enq/Collective No :E5A1Z35637

Enq.Dt. : 20.04.2026

No.Of Items :*

DUE Dt. OF QUOTN. : 04.05.2026

Office Copy

Please submit your lowest quotation in sealed cover superscribed with Enquiry No./Collective No.(RFQ No) and due date subject to our terms and conditions attached ,for the materials mentioned below.Your offer has to reach us onor before due date by 11.00 Hours (IST) and will be opened at 14.00 Hours.(IST).If our Enquiry No./Collective No.(RFQ No) and tender due date are not super scribed on the tender cover , your offer shall be summarily rejected. Incomplete offers and late offers will not be considered.

SL NO	Purchase Req.no	item no	Material Code, HSN No.	Drg no - Ver , Rev & Spec - Ver , Rev,Spec-Var	Description	Unit	Qty	Delivery Date	Schedule Qty
51	8000139208	130	73269099					15.12.2026	1.000
52	8000139208	140	73269099					15.12.2026	1.000
53	8000139208	150	73269099					15.12.2026	1.000
54	8000139208	160	73269099					15.12.2026	1.000
55	8000139208	170	73269099					15.12.2026	1.000
56	8000139208	180	73269099					15.12.2026	1.000
57	8000139481	10	73269099					10.01.2027	1.000
58	8000139481	20	73269099					10.01.2027	1.000
59	8000139481	30	73269099					10.01.2027	1.000
60	8000139481	40	73269099					10.01.2027	1.000

TEST CERTIFICATE REQD:
GUARANTEE REQ :
SAMPLE REQD :
BID TYPE : TWO PARTFor and on-behalf of
Bharat Heavy Electricals Limited.Arief Ahmed Choudhury
BHEL Hyderabad/HEF Purchase

**BHARAT HEAVY ELECTRICALS LIMITED**

[A Government of India Undertaking]

Ramachandrapuram, Hyderabad, 502032, A.P. India
Phone 040-23184526, 23182322 FAX:040-23021910, 1954**भारत हेवी इलेक्ट्रिकल्स लिमिटेड**

(भारत सरकार का उपक्रम)

रामचन्द्रपुरम, हैदराबाद, 502032 आंध्र प्रदेश, भारत

RFQ NO :

PURCHASE DEPARTMENT**ENQUIRY****क्रय विभाग**

जांच (ई मेल : tenderbox@bhellhyd.co.in)

SHEET:7
OF :13HY17001 C
REV.NO.0Phone 091-40-23184526
091-40-23182322FAX : 091-40-23021910
091-40-23021954**PURCHASE DEPARTMENT**

GSTIN:

Enq/Collective No :E5A1Z35637

Enq.Dt. : 20.04.2026

No.Of Items :*

DUE Dt. OF QUOTN. : 04.05.2026

Office Copy

Please submit your lowest quotation in sealed cover superscribed with Enquiry No./Collective No.(RFQ No) and due date subject to our terms and conditions attached ,for the materials mentioned below.Your offer has to reach us onor before due date by 11.00 Hours (IST) and will be opened at 14.00 Hours.(IST).If our Enquiry No./Collective No.(RFQ No) and tender due date are not super scribed on the tender cover , your offer shall be summarily rejected. Incomplete offers and late offers will not be considered.

SL NO	Purchase Req.no	item no	Material Code, HSN No.	Drg no - Ver , Rev & Spec - Ver , Rev,Spec-Var	Description	Unit	Qty	Delivery Date	Schedule Qty
61	8000139481	50	73269099					10.01.2027	1.000
62	8000139481	60	73269099					10.01.2027	1.000
63	8000139481	180	73269099					10.03.2027	1.000
64	8000139481	170	73269099					10.03.2027	1.000
65	8000139481	160	73269099					10.03.2027	1.000
66	8000139481	150	73269099					10.03.2027	1.000
67	8000139481	140	73269099					10.03.2027	1.000
68	8000139481	130	73269099					10.03.2027	1.000
69	8000139483	140	73269099					10.05.2027	1.000
70	8000139483	130	73269099					10.05.2027	1.000

TEST CERTIFICATE REQD:
GUARANTEE REQ :
SAMPLE REQD :
BID TYPE : TWO PART

For and on-behalf of
Bharat Heavy Electricals Limited.

Arief Ahmed Choudhury
BHEL Hyderabad/HEF Purchase

**BHARAT HEAVY ELECTRICALS LIMITED**

[A Government of India Undertaking]

Ramachandrapuram, Hyderabad, 502032, A.P. India
Phone 040-23184526, 23182322 FAX:040-23021910, 1954**भारत हेवी इलेक्ट्रिकल्स लिमिटेड**

(भारत सरकार का उपक्रम)

रामचन्द्रपुरम, हैदराबाद, 502032 आंध्र प्रदेश, भारत

RFQ NO :

PURCHASE DEPARTMENT**ENQUIRY****क्रय विभाग**

जांच (ई मेल : tenderbox@bhellhyd.co.in)

SHEET:8
OF :13HY17001 C
REV.NO.0Phone 091-40-23184526
091-40-23182322FAX : 091-40-23021910
091-40-23021954**PURCHASE DEPARTMENT**

GSTIN:

Enq/Collective No :E5A1Z35637

Enq.Dt. : 20.04.2026

No.Of Items :*

DUE Dt. OF QUOTN : 04.05.2026

Office Copy

Please submit your lowest quotation in sealed cover superscribed with Enquiry No./Collective No.(RFQ No) and due date subject to our terms and conditions attached ,for the materials mentioned below.Your offer has to reach us onor before due date by 11.00 Hours (IST) and will be opened at 14.00 Hours.(IST).If our Enquiry No./Collective No.(RFQ No) and tender due date are not super scribed on the tender cover , your offer shall be summarily rejected. Incomplete offers and late offers will not be considered.

SL NO	Purchase Req.no	item no	Material Code, HSN No.	Drg no - Ver , Rev & Spec - Ver , Rev,Spec-Var	Description	Unit	Qty	Delivery Date	Schedule Qty
71	8000139483	60	73269099					10.04.2027	1.000
72	8000139483	50	73269099					10.04.2027	1.000
73	8000139483	40	73269099					10.04.2027	1.000
74	8000139483	30	73269099					10.04.2027	1.000
75	8000139483	150	73269099					10.05.2027	1.000
76	8000139483	160	73269099					10.05.2027	1.000
77	8000139483	170	73269099					10.05.2027	1.000
78	8000139483	180	73269099					10.05.2027	1.000
79	8000139483	20	73269099					10.04.2027	1.000
80	8000139483	70	HE9712844285 73269099	41750103663-02,00,HE51546,,NA	TEST COUPON FOR HEMIHEAD FORGING	EA	42.000	10.04.2027	1.000

TEST CERTIFICATE REQD:
GUARANTEE REQ :
SAMPLE REQD :
BID TYPE : TWO PART

For and on-behalf of
Bharat Heavy Electricals Limited.

Arief Ahmed Choudhury
BHEL Hyderabad/HEF Purchase

**BHARAT HEAVY ELECTRICALS LIMITED**

[A Government of India Undertaking]

Ramachandrapuram, Hyderabad, 502032, A.P. India
Phone 040-23184526, 23182322 FAX:040-23021910, 1954**भारत हेवी इलेक्ट्रिकल्स लिमिटेड**

(भारत सरकार का उपक्रम)

रामचन्द्रपुरम, हैदराबाद, 502032 आंध्र प्रदेश, भारत

RFQ NO :

PURCHASE DEPARTMENT**ENQUIRY****क्रय विभाग**

जांच (ई मेल : tenderbox@bhellhyd.co.in)

SHEET:9
OF :13HY17001 C
REV.NO.0Phone 091-40-23184526
091-40-23182322FAX : 091-40-23021910
091-40-23021954**PURCHASE DEPARTMENT**

GSTIN:

Enq/Collective No :E5A1Z35637

Enq.Dt. : 20.04.2026

No.Of Items :*

DUE Dt. OF QUOTN. : 04.05.2026

Office Copy

Please submit your lowest quotation in sealed cover superscribed with Enquiry No./Collective No.(RFQ No) and due date subject to our terms and conditions attached ,for the materials mentioned below.Your offer has to reach us onor before due date by 11.00 Hours (IST) and will be opened at 14.00 Hours.(IST).If our Enquiry No./Collective No.(RFQ No) and tender due date are not super scribed on the tender cover , your offer shall be summarily rejected. Incomplete offers and late offers will not be considered.

SL NO	Purchase Req.no	item no	Material Code, HSN No.	Drg no - Ver , Rev & Spec - Ver , Rev,Spec-Var	Description	Unit	Qty	Delivery Date	Schedule Qty
81	8000137261	120	73269099					01.11.2026	1.000
82	8000137261	110	73269099					01.11.2026	1.000
83	8000137261	100	73269099					01.11.2026	1.000
84	8000137261	90	73269099					01.11.2026	1.000
85	8000137261	80	73269099					01.11.2026	1.000
86	8000137261	70	73269099					01.11.2026	1.000
87	8000139208	80	73269099					10.11.2026	1.000
88	8000139208	70	73269099					10.11.2026	1.000
89	8000139208	90	73269099					10.11.2026	1.000
90	8000139208	100	73269099					10.11.2026	1.000

TEST CERTIFICATE REQD:
GUARANTEE REQ :
SAMPLE REQD :
BID TYPE : TWO PARTFor and on-behalf of
Bharat Heavy Electricals Limited.

Arief Ahmed Choudhury
BHEL Hyderabad/HEF Purchase

**BHARAT HEAVY ELECTRICALS LIMITED**

[A Government of India Undertaking]

Ramachandrapuram, Hyderabad, 502032, A.P. India
Phone 040-23184526, 23182322 FAX:040-23021910, 1954**भारत हेवी इलेक्ट्रिकल्स लिमिटेड**

(भारत सरकार का उपक्रम)

रामचन्द्रपुरम, हैदराबाद, 502032 आंध्र प्रदेश, भारत

RFQ NO :

PURCHASE DEPARTMENT**ENQUIRY****क्रय विभाग**

जांच (ई मेल : tenderbox@bhellhyd.co.in)

SHEET:10
OF :13HY17001 C
REV.NO.0Phone 091-40-23184526
091-40-23182322FAX : 091-40-23021910
091-40-23021954**PURCHASE DEPARTMENT**

GSTIN:

Enq/Collective No :E5A1Z35637

Enq.Dt. : 20.04.2026

No.Of Items :*

DUE Dt. OF QUOTN : 04.05.2026

Office Copy

Please submit your lowest quotation in sealed cover superscribed with Enquiry No./Collective No.(RFQ No) and due date subject to our terms and conditions attached ,for the materials mentioned below.Your offer has to reach us onor before due date by 11.00 Hours (IST) and will be opened at 14.00 Hours.(IST).If our Enquiry No./Collective No.(RFQ No) and tender due date are not super scribed on the tender cover , your offer shall be summarily rejected. Incomplete offers and late offers will not be considered.

SL NO	Purchase Req.no	item no	Material Code, HSN No.	Drg no - Ver , Rev & Spec - Ver , Rev,Spec-Var	Description	Unit	Qty	Delivery Date	Schedule Qty
91	8000139208	110	73269099					10.11.2026	1.000
92	8000139208	120	73269099					10.11.2026	1.000
93	8000139208	190	73269099					15.12.2026	1.000
94	8000139208	240	73269099					15.12.2026	1.000
95	8000139208	230	73269099					15.12.2026	1.000
96	8000139208	220	73269099					15.12.2026	1.000
97	8000139208	210	73269099					15.12.2026	1.000
98	8000139208	200	73269099					15.12.2026	1.000
99	8000139481	190	73269099					10.03.2027	1.000
100	8000139481	120	73269099					10.01.2027	1.000

TEST CERTIFICATE REQD:
GUARANTEE REQ :
SAMPLE REQD :
BID TYPE : TWO PARTFor and on-behalf of
Bharat Heavy Electricals Limited.

Arief Ahmed Choudhury
BHEL Hyderabad/HEF Purchase

**BHARAT HEAVY ELECTRICALS LIMITED**

[A Government of India Undertaking]

Ramachandrapuram, Hyderabad, 502032, A.P. India
Phone 040-23184526, 23182322 FAX:040-23021910, 1954**भारत हेवी इलेक्ट्रिकल्स लिमिटेड**

(भारत सरकार का उपक्रम)

रामचन्द्रपुरम, हैदराबाद, 502032 आंध्र प्रदेश, भारत

RFQ NO :

PURCHASE DEPARTMENT**ENQUIRY**

क्रय विभाग

जांच (ई मेल : tenderbox@bhellhyd.co.in)

SHEET:11
OF :13HY17001 C
REV.NO.0Phone 091-40-23184526
091-40-23182322FAX : 091-40-23021910
091-40-23021954**PURCHASE DEPARTMENT**

GSTIN:

Enq/Collective No :E5A1Z35637

Enq.Dt. : 20.04.2026

No.Of Items :*

DUE Dt. OF QUOTN. : 04.05.2026

Office Copy

Please submit your lowest quotation in sealed cover superscribed with Enquiry No./Collective No.(RFQ No) and due date subject to our terms and conditions attached ,for the materials mentioned below.Your offer has to reach us onor before due date by 11.00 Hours (IST) and will be opened at 14.00 Hours.(IST).If our Enquiry No./Collective No.(RFQ No) and tender due date are not super scribed on the tender cover , your offer shall be summarily rejected. Incomplete offers and late offers will not be considered.

SL NO	Purchase Req.no	item no	Material Code, HSN No.	Drg no - Ver , Rev & Spec - Ver , Rev,Spec-Var	Description	Unit	Qty	Delivery Date	Schedule Qty
101	8000139481	110	73269099					10.01.2027	1.000
102	8000139481	100	73269099					10.01.2027	1.000
103	8000139481	90	73269099					10.01.2027	1.000
104	8000139481	80	73269099					10.01.2027	1.000
105	8000139481	70	73269099					10.01.2027	1.000
106	8000139481	200	73269099					10.03.2027	1.000
107	8000139481	210	73269099					10.03.2027	1.000
108	8000139481	220	73269099					10.03.2027	1.000
109	8000139481	230	73269099					10.03.2027	1.000
110	8000139481	240	73269099					10.03.2027	1.000

TEST CERTIFICATE REQD:
GUARANTEE REQ :
SAMPLE REQD :
BID TYPE : TWO PARTFor and on-behalf of
Bharat Heavy Electricals Limited.

Arief Ahmed Choudhury
BHEL Hyderabad/HEF Purchase

**BHARAT HEAVY ELECTRICALS LIMITED**

[A Government of India Undertaking]

Ramachandrapuram, Hyderabad, 502032, A.P. India
Phone 040-23184526, 23182322 FAX:040-23021910, 1954**भारत हेवी इलेक्ट्रिकल्स लिमिटेड**

(भारत सरकार का उपक्रम)

रामचन्द्रपुरम, हैदराबाद, 502032 आंध्र प्रदेश, भारत

RFQ NO :

PURCHASE DEPARTMENT**ENQUIRY****क्रय विभाग**

जांच (ई मेल : tenderbox@bhellhyd.co.in)

SHEET:12
OF :13

HY17001 C REV.NO.0	Phone 091-40-23184526 091-40-23182322	FAX : 091-40-23021910 091-40-23021954	PURCHASE DEPARTMENT			
GSTIN:		Enq/Collective No :E5A1Z35637	Enq.Dt. : 20.04.2026	No.Of Items :*	DUE Dt. OF QUOTN. : 04.05.2026	

Office Copy

Please submit your lowest quotation in sealed cover superscribed with Enquiry No./Collective No.(RFQ No) and due date subject to our terms and conditions attached ,for the materials mentioned below.Your offer has to reach us onor before due date by 11.00 Hours (IST) and will be opened at 14.00 Hours.(IST).If our Enquiry No./Collective No.(RFQ No) and tender due date are not super scribed on the tender cover , your offer shall be summarily rejected. Incomplete offers and late offers will not be considered.

SL NO	Purchase Req.no	item no	Material Code, HSN No.	Drg no - Ver , Rev & Spec - Ver , Rev,Spec-Var	Description	Unit	Qty	Delivery Date	Schedule Qty
111	8000139483	220	73269099					10.05.2027	1.000
112	8000139483	230	73269099					10.05.2027	1.000
113	8000139483	240	73269099					10.05.2027	1.000
114	8000139483	210	73269099					10.05.2027	1.000
115	8000139483	200	73269099					10.05.2027	1.000
116	8000139483	190	73269099					10.05.2027	1.000
117	8000139483	80	73269099					10.04.2027	1.000
118	8000139483	90	73269099					10.04.2027	1.000
119	8000139483	100	73269099					10.04.2027	1.000
120	8000139483	110	73269099					10.04.2027	1.000

TEST CERTIFICATE REQD:
GUARANTEE REQ :
SAMPLE REQD :
BID TYPE : TWO PART

For and on-behalf of
Bharat Heavy Electricals Limited.

Arief Ahmed Choudhury
BHEL Hyderabad/HEF Purchase

	BHARAT HEAVY ELECTRICALS LIMITED [A Government of India Undertaking] Ramachandrapuram, Hyderabad, 502032, A.P. India Phone 040-23184526, 23182322 FAX:040-23021910, 1954	भारत हेवी इलेक्ट्रिकल्स लिमिटेड (भारत सरकार का उपक्रम) रामचन्द्रपुरम, हैदराबाद, 502032 आंध्र प्रदेश, भारत	RFQ NO :	PURCHASE DEPARTMENT ENQUIRY क्रय विभाग जांच (ई मेल : tenderbox@bhelhyd.co.in)	SHEET:13 OF :13
--	--	--	----------	--	--------------------

HY17001 C REV.NO.0	Phone 091-40-23184526 091-40-23182322	FAX : 091-40-23021910 091-40-23021954	PURCHASE DEPARTMENT		
GSTIN:		Enq/Collective No :E5A1Z35637	Enq.Dt : 20.04.2026	No.Of Items :*	DUE Dt. OF QUOTN : 04.05.2026

Office Copy

Please submit your lowest quotation in sealed cover superscribed with Enquiry No./Collective No.(RFQ No) and due date subject to our terms and conditions attached ,for the materials mentioned below.Your offer has to reach us onor before due date by 11.00 Hours (IST) and will be opened at 14.00 Hours.(IST).If our Enquiry No./Collective No.(RFQ No) and tender due date are not super scribed on the tender cover , your offer shall be summarily rejected. Incomplete offers and late offers will not be considered.

SL NO	Purchase Req.no	item no	Material Code, HSN No.	Drg no - Ver , Rev & Spec - Ver , Rev,Spec-Var	Description	Unit	Qty	Delivery Date	Schedule Qty
121	8000139483	120	73269099					10.04.2027	1.000
122	8000140750	10	HE9712844293 73269099	41750103667-01,00,HE51546,,NA	HEMIHEAD FORGING(ID1303 X 150THK)	EA	14.000	10.04.2027	1.000
123	8000137265	20	73269099					01.11.2026	1.000
124	8000137265	10	73269099					01.11.2026	1.000

Special Remarks

CheckList of Quality Interventions:

BHEL reserves the right to enforce any or all of the following checks during execution of the order.
There is no additional cost to the vendor on account of these checks.

TEST CERTIFICATE REQD:
GUARANTEE REQ :
SAMPLE REQD :
BID TYPE : TWO PART

For and on-behalf of
Bharat Heavy Electricals Limited.

Arief Ahmed Choudhury
BHEL Hyderabad/HEF Purchase

THE INFORMATION ON THIS DOCUMENT IS THE PROPERTY OF **BHARAT HEAVY ELECTRICALS LIMITED**
IT MUST NOT BE USED DIRECTLY OR INDIRECTLY IN ANY WAY DETRIMENTAL TO THE INTEREST OF THE COMPANY

GEN. DIM. LIMITS, FITS, & TOLERANCES AS PER P.S. :- HY0230261

REV.	DATE	ALTD	CHD	APPD	REV.	DATE	ALTD	CHD	APPD	REV.	DATE	ALTD	CHD	APPD

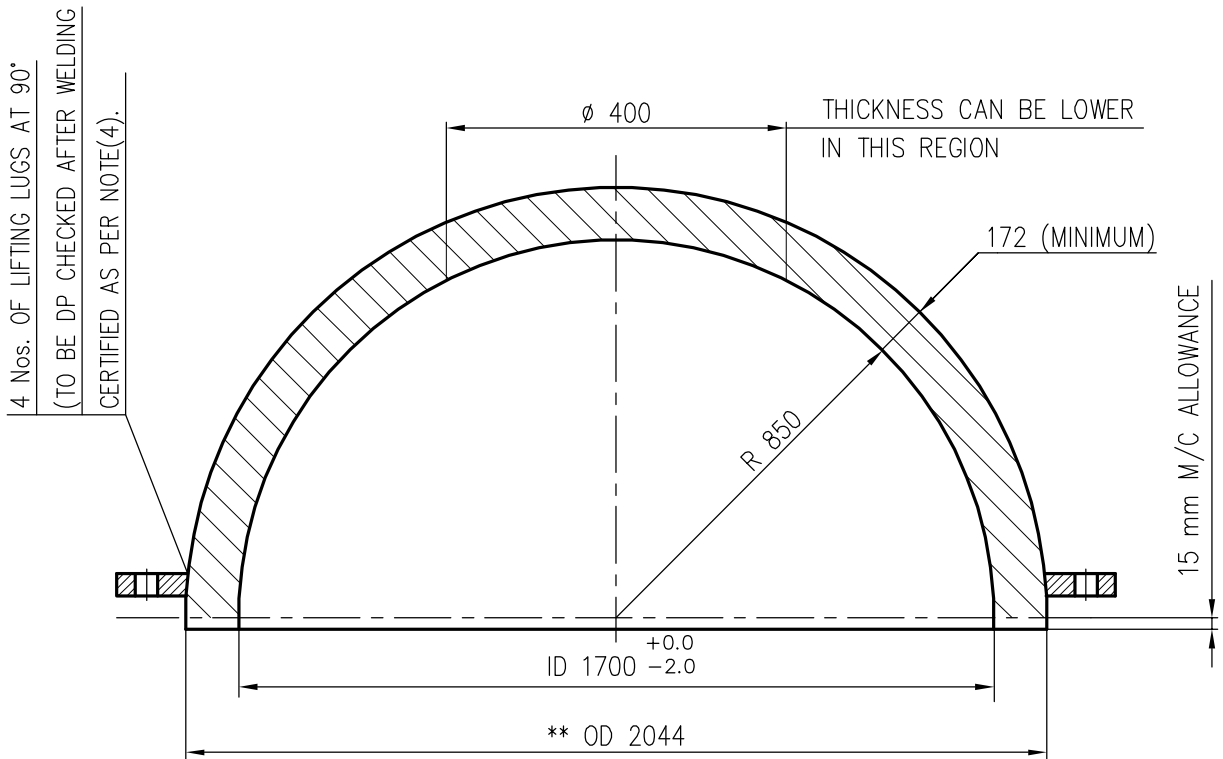

NOTES:-

1. MATERIAL : SA 266 GR.2 AS PER ASME SECTION-II PART-A EDN AND ADDENDA AS PER P.O/ENQUIRY.
2. TECHNICAL REQUIREMENTS AS PER PROD STD HE51546 LATEST REVISION AS PER P.O./ENQUIRY.
3. ULTRASONIC TESTING SHALL BE CARRIED OUT BEFORE AND AFTER FORMING AS PER A388.ACCEPTANCE SHALL BE AS PER PRODUCT STANDARD HE 71044.
3. QUALITY REQUIREMENTS AS PER QUALITY PLAN DOCUMENT MENTIONED IN P.O/ENQUIRY.
4. INSPECTION & CERIFICATION : AS PER CLAUSE NO.12 OF PRODUCT STANDARD HE 51546.
5. MAX. WORKING PRESSURE (DESIGN PRESSURE) : 390 Kg/Sq.Cm.(g)
6. MAX. WORKING TEMPERATURE (DESIGN TEMPERATURE) : 318° C
7. CODE No. FOR HEMIHEAD : HE9712844250 , WEIGHT = 9030 Kg.
8. CODE No. FOR TEST COUPON : HE9712844269, WEIGHT = 98 Kg (SIZE :- THK X 250 X250).
- **9. OD OF HEMIHEAD UPTO 2100 IS ACCEPTABLE CONSIDERING HIGHER THICK FORGE BLANK TO ACHIEVE 172 MIN THK AFTER FORMING

REMARKS	ITEM NO	DESCRIPTION	STD	MATL. CODE	A/C	UNIT	UNIT Wt.
				MATL. SPEN.			QTY.
		BHARAT HEAVY ELECTRICALS LTD. HYDERABAD		NAME	SIGN.	DATE	NO.OF VAR.
DEPT. HE ENGG	UNTOL. DIM. GR.	SCALE	WEIGHT (KG)	DRN. RAJESH M	M.RAJESH	14.03.24	NA
CODE 405	Ø/M/F	NTS	NA	CHD. A.K.SAHOO	A.K.S	14.03.24	
				APPD. K. KISHORE KUMAR	K.K.K.	14.03.24	
TITLE				DRAWING NO.		REV.	
HEMI HEAD				4-175-01-03637		00	
<p style="color: red; font-weight: bold;">16-Mar-2024 10:20 AM RELEASED TO THE PUBLIC BY THE COMPANY. Signatures are not required</p>				CARD CODE		No of SHE 1	

FIRST ANGLE PROJECTION

(ALL DIMENSIONS ARE IN mm)

THE INFORMATION ON THIS DOCUMENT IS THE PROPERTY OF BHARAT HEAVY ELECTRICALS LIMITED
IT MUST NOT BE USED DIRECTLY OR INDIRECTLY IN ANY WAY DETRIMENTAL TO THE INTEREST OF THE COMPANY

GEN. DIM. LIMITS, FITS, & TOLERANCES AS PER P.S :- HY0230261

REV.	DATE	ALTERED	CHD	APPD	REV.	DATE	ALTD	CHD	APPD	REV.	DATE	ALTD	CHD	APPD

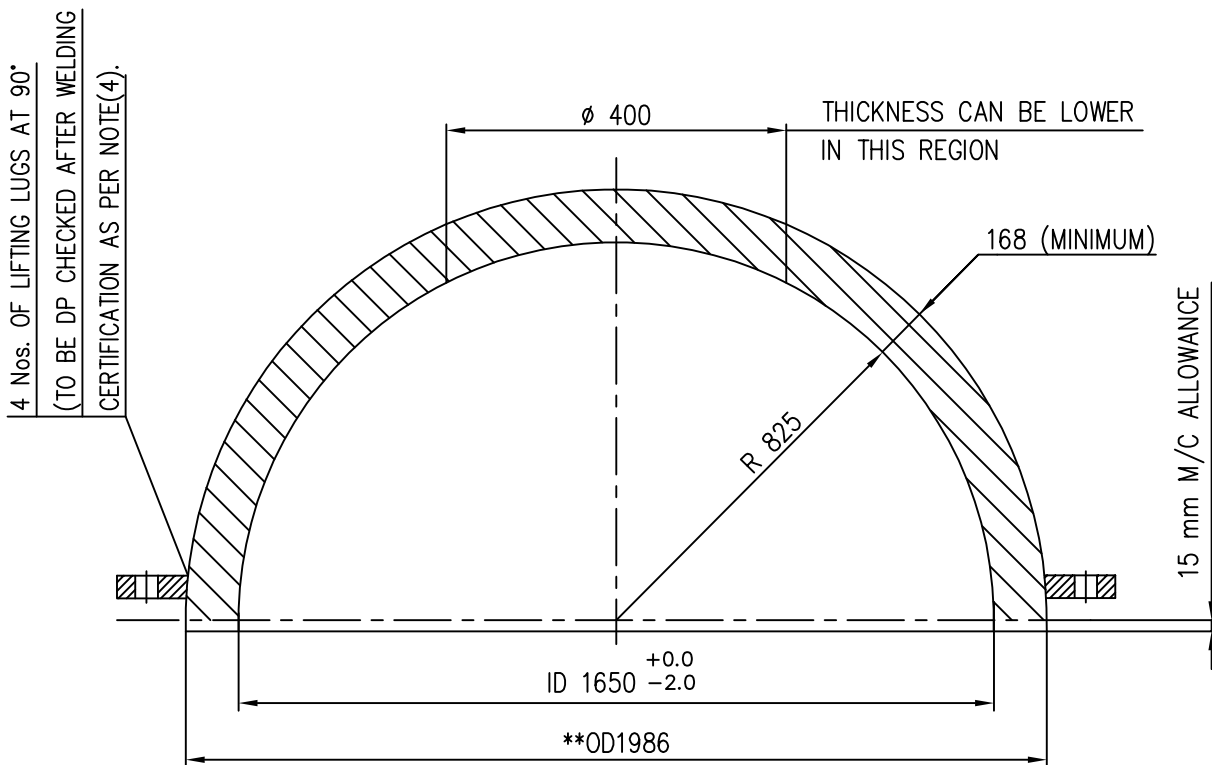

NOTES: -

1. MATERIAL : SA 266 GR.2 AS PER ASME SEC II PART A EDN & ADDENDA AS PER PO/ENQUIRY
2. TECHNICAL REQUIREMENTS AS PER PROD STD HE51546 LATEST REVISION AS PER PO/ENQUIRY.
3. ULTRASONIC TEST SHALL BE CARRIED OUT BEFORE AND AFTER FORMING AS PER SA388.ACCEPTANCE SHALL BE AS PER PRODUCT STANDARD HE71044.
4. QUALITY REQUIREMENTS AS PER QUALITY PLAN DOCUMENT MENTIONED IN PO/ENQUIRY
4. INSPECTION & CERIFICATION : AS PER CLAUSE NO 12 OF PROD STD HE51546.
5. MAX. WORKING PRESSURE (DESIGN PRESSURE) : 390 Kg/Sq.Cm.(g)
6. MAX. WORKING TEMPERATURE (DESIGN TEMPERATURE) : 318° C
7. CODE No. FOR HEMIHEAD : HE9712844277 , WEIGHT = 8600 Kg.
8. CODE No. FOR TEST COUPON :HE9712844285 , WEIGHT = 98 Kg. (SIZE:-THK. X 250 X 250)
- **9. OD OF HEMIHEAD UPTO 2050 IS ACCEPTABLE CONSIDERING HIGHER THICK FORGE BLANK TO ACHIEVE 168MIN THK AFTER FORMING .

REMARKS	ITEM NO	DESCRIPTION	STD	MATL. CODE	A/C	UNIT	UNIT Wt.
				MATL. SPEN.			QTY.



BHARAT HEAVY ELECTRICALS LTD.
HYDERABAD

	NAME	SIGN.	DATE	NO.OF VAR.
DRN.	A K SAHOO	AKS	29.06.24	NA
CHD.	K KISHORE KUMAR	KKK	29.06.24	
APPD.	K KIRAN KUMAR	KKIRAN	29.06.24	

DEPT. HE ENGG	UN.TOL. DIM. GR.	SCALE	WEIGHT (KG)	REF. TO ASSY DRG.	ITEM NO.	NO.OF ITEMS
CODE 405	Ø/M/F	NTS	NA	NA	NA	NA

TITLE	CARD CODE	DRAWING NO.	REV.
HEMI HEAD FORGING	NA	4-175-01-03663	00

02-Nov-2024 18:50:09 (FOR 800MW JIPHS) SPP Released. Signatures are not required

THE INFORMATION ON THIS DOCUMENT IS THE PROPERTY OF BHARAT HEAVY ELECTRICALS LIMITED
IT MUST NOT BE USED DIRECTLY OR INDIRECTLY IN ANY WAY DETRIMENTAL TO THE INTEREST OF THE COMPANY

GEN. DIM. LIMITS, FITS, & TOLERANCES AS PER P.S. :- HY0230261

REV.	DATE	ALTERED	CHD	APPD	REV.	DATE	ALTD	CHD	APPD	REV.	DATE	ALTD	CHD	APPD

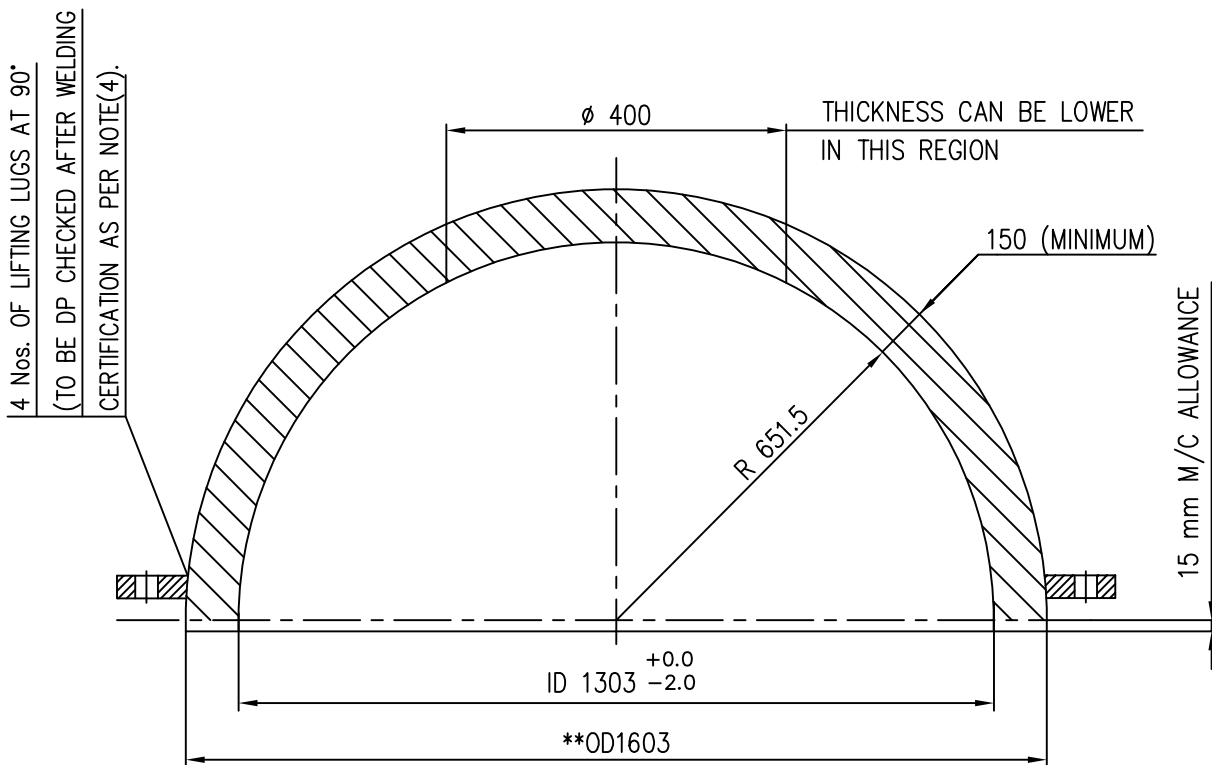

NOTES: -

1. MATERIAL : SA 266 GR.2 AS PER ASME SEC II PART A EDN & ADDENDA AS PER PO/ENQUIRY
2. TECHNICAL REQUIREMENTS AS PER PROD STD HE51546 LATEST REVISION AS PER PO/ENQUIRY.
3. ULTRASONIC TEST SHALL BE CARRIED OUT BEFORE AND AFTER FORMING AS PER SA388.ACCEPTANCE SHALL BE AS PER PRODUCT STANDARD HE71044.
4. QUALITY REQUIREMENTS AS PER QUALITY PLAN DOCUMENT MENTIONED IN PO/ENQUIRY
4. INSPECTION & CERIFICATION : AS PER CLAUSE NO 12 OF PROD STD HE51546.
5. MAX. WORKING PRESSURE (DESIGN PRESSURE) : 390 Kg/Sq.Cm.(g)
6. MAX. WORKING TEMPERATURE (DESIGN TEMPERATURE) : 350° C
7. CODE No. FOR HEMI HEAD : HE9712844293, WEIGHT = 5010 Kg.
8. CODE No. FOR TEST COUPON :HE9712844307, WEIGHT = 89 Kg. (SIZE:-180THK. X 250 X 250)
- **9. OD OF HEMIHEAD UPTO 1703 IS ACCEPTABLE CONSIDERING HIGHER THICK FORGE BLANK TO ACHIEVE 150MIN THK AFTER FORMING .

REMARKS	ITEM NO	DESCRIPTION	STD	MATL. CODE	A/C	UNIT	UNIT Wt.
				MATL. SPEN.			QTY.



BHARAT HEAVY ELECTRICALS LTD.
HYDERABAD

NAME	SIGN.	DATE	NO.OF VAR.
DRN. A K SAHOO	AKS	29.06.24	NA
CHD. K KISHORE KUMAR	KKK	29.06.24	
APPD. K KIRAN KUMAR	KKIRAN	29.06.24	

DEPT. HE ENGG	UNTO. DIM. GR.	SCALE	WEIGHT (KG)	REF. TO ASSY DRG.	ITEM NO.	NO.OF ITEMS
CODE 405	Ø/M/F	NTS	NA	NA	NA	NA

TITLE	CARD CODE	DRAWING NO.	REV.
HEMI HEAD FORGING	4-175-01-03667	4-175-01-03667	00



TD-106-1 Rev-06	Form No.		<p align="center">PRODUCT STANDARD HEAT EXCHANGERS HYDERABAD</p>		No: HE 51546
					REV. NO. 01
					PAGE 1 OF 3

SPECIFICATION FOR H.P. HEATER HEMIHEAD FORGING FOR FEED WATER HEATERS

1. The forging shall confirm in all respects to SA266 Gr.2 of ASME SEC-II part-A, year of edition and addenda as specified in drawing. /enquiry/P.O. Hemihead shall be formed from a single forging.

2. Both heat & product analysis shall be certified.

3. Over & above the specification requirement of the forging, the following supplementary requirements are to be met: -

(a) S4: - Magnetic Particle Examination as per A275. Acceptance shall be as per Appx. '6' of ASME Section VIII Division -1.

(b) S13: - Charpy impact tests

4. The impact testing of the plate as per A370 & the acceptance values shall be as follows:

Test temp.	Average of 3 specimens (J)	Individual min. (J)
-46 deg. C	20.0	16.0

5. Ultrasonic testing shall be carried out before and after forming as per A388. Acceptance shall be as per standard HE71044.

6. Along with each Hemihead, an attested test coupon of size as per drawing from the same cast/heat shall be supplied for proving C-seam at BHEL.

7. Hemihead shall be normalized after forming, even if formed, in normalized temperature range. Heat treatment shall be furnished. Supplier shall prove the mechanical properties of the Hemihead on a test coupon which has been subjected to the same heat treatment cycle.

8. Limit on out of roundness & tolerance on inside diameter shall be as per drawing mentioned in P.O/Enquiry.

9. Magnetic particle test shall be carried out on outer surface of Hemihead after forming. Acceptance shall be as per Appx. '6' of ASME VIII Div.1.

Ref.Doc	Revision:	Prepared:	Approved:	Date:
	Refer to record of revision	S Bhattacharya	K Kishore Kumar	22.06.2017

COPYRIGHT AND CONFIDENTIAL. The information on this document is the property of BHARAT HEAVY ELECTRICALS LIMITED. It must not be used directly or indirectly in any way detrimental to the interest of the company

TD-106-2
Rev-06

Form No.



PRODUCT STANDARD
HEAT EXCHANGERS
HYDERABAD

No: **HE 51546**

REV. NO. 01

PAGE 2 OF 3

COPYRIGHT AND CONFIDENTIAL
The information on this document is the property of BHARAT HEAVY ELECTRICALS LIMITED.
It must not be used directly or indirectly in any way detrimental to the interest of the company

10. Minimum thickness as specified on the drawing shall be ensured after forming.

11. Temporary rust preventive shall be applied for protection during transit & storage.

12. Inspection and Certification:

- a) Where the material is sourced from suppliers other than India, the certification shall be in IBR form III-I duly signed by BHEL Approved Third Party Inspection Agency (BHEL TPIA). BHEL TPIA shall be authorized by Central Boiler Board for that country.
- b) Where the material is sourced from Indigenous Suppliers, the certification shall be by Director of Boilers in form III-I and also by BHEL Approved Third Party Inspection Agency (BHEL TPIA) as per ASME SEC.II Part A. Edition & Addenda as indicated in the drawing/P. O & enclosed quality plan.



BHARAT HEAVY ELECTRICALS
LIMITED
R.C.PURAM, HYDERABAD

STANDARD QUALITY PLAN FOR VENDOR ITEMS
ITEM: SPECIFICATION FOR H.P. HEATER HEMIHEAD
FOR FEED WATER HEATERS
BHEL SPEC: HE 51546 REV AS PER PO
BHEL DRG : AS PER P.O.
PROJECT: ADANI PROJECTS

QP. NO: HYQA/VSQP/2024-25/HE 51546/ADANI
REV. NO. : 01
DATE: 29.10.2024
PAGE 1 OF 2

SL	COMPONENT & OPERATIONS	CHARACTERISTICS	CLASS	TYPE OF CHECK	QUANTUM OF CHECK	REF DOCUMENT	ACCEPTANCE NORMS	FORMAT OF RECORD	* D	AGENCY			REMARKS
										P	W	V	
1.0	HEMI HEAD												
1.1	STEEL MAKING	STEEL MAKING PROCESS	MAJOR	LADLE CHEMISTRY	EACH HEAT	MFR STD	SA 266 GR 2/ BHEL SPEC	MILL TC	✓	2		1	Note-A
1.2		CHECK ANALYSIS	MAJOR	SPECTRO ANALYSIS	SAMPLE /HEAT	SA 266 GR 2/ BHEL SPEC		MILL TC		2			
1.3	FORGING BLANK	FORGING STEP TO BE FOLLOWED	MAJOR	MFR PROCESS	100%	MFR STD/ DRG		IR		2			
1.4		REDUCTION RATIO	MAJOR	MFR PROCESS	100%	MFR STD/ DRG		IR	✓	2		1	MIN 3:1
1.5	HEMI HEAD	INTERNAL SOUNDNESS-NDE BEFORE FORMING	MAJOR	UT	100%	SA 388	HE71044	IR	✓	2		1	
1.6		FORMING OPERATION	MAJOR	VISUAL, MEASRT	100%	MFR STD		MFR STD, DRG		2			
1.7		TEST PIECE MARKING- 1. MECH TESTING 2. C SEAM TEST COUPONS	MAJOR	VISUAL,MEASRT	100%	ASME SEC. VIII DIV.1, BHEL DRG,		IR	✓	2		1	CORELATION OF TEST COUPON SHALL BE ESTABLISHED
1.8		HEAT TREATMENT AFTER FORMING TEMP, TIME ETC	MAJOR	HT CYCLE	100%	SA 266 GR 2/ BHEL SPEC		HT CHART, HT REPORT	✓	2		1	
1.9		PRODUCT ANALYSIS	MAJOR	COMPOSITION	SAMPLE /HEAT	SA 266 GR 2/ BHEL SPEC		IR	✓	2		1	
1.10		MECH PROPERTIES	MAJOR	MECH	AS PER SPEC	SA 266 GR 2/ BHEL SPEC		IR	✓	2		1	
1.11		IMPACT @ SPECIFIED TEMPERATURE (IF SPECIFIED IN DRAWING/ SPEC)	MAJOR	MECH	AS PER SPEC	SA 266 GR 2/ BHEL SPEC		IR	✓	2		1	
1.12		UT EXAM. AFTER FORMING	MAJOR	NDE	100%	SA 388	HE71044	IR	✓	2	1		

VENDOR TO SUBMIT DRAWING ANDTECH.DATASHEET FFOR BHEL APPROVAL.

LEGEND:

P: - PERFORM, W: - WITNESS, V: - VERIFICATION,

INDICATING 1: - BHEL / BHEL NOMMNATED INSPECTION AGENCY, 2: - VENDOR / SUB VENDOR 3 : CUSTOMER / CUSTOMER TPIA AS APPROPRIATE AGAINST EACH COMPONENT / CHARACTERISTICS UNDER THE COLUMNS P, W & V.

* D: RECORDS IDENTIFIED WITH TICK (✓) SHALL BE ESSENTIALLY INCLUDED IN QA DOCUMENTATION.

PREPARED BY:

Alok Behera

ALOK BEHERA
MGR / QA

REVIEWED BY:

Samath
YUSTELA SAMPATH KUMAR
Sr. Manager - Quality & Technical Excellence
BHEL Limited, Hyderabad

APPROVED BY:

T. Muniraghavulu

T MUNIRAGHAVULU
AGM/QA



BHARAT HEAVY ELECTRICALS
LIMITED
R.C.PURAM, HYDERABAD

STANDARD QUALITY PLAN FOR VENDOR ITEMS
ITEM: SPECIFICATION FOR H.P. HEATER HEMIHEAD
FOR FEED WATER HEATERS
BHEL SPEC: HE 51546 REV AS PER PO
BHEL DRG : AS PER P.O.
PROJECT: ADANI PROJECTS

QP. NO: HYQA/VSQP/2024-25/HE 51546/ADANI
REV. NO. : 01
DATE: 29.10.2024
PAGE 2 OF 2

SL	COMPONENT & OPERATIONS	CHARACTERISTICS	CLASS	TYPE OF CHECK	QUANTUM OF CHECK	REF DOCUMENT	ACCEPTANCE NORMS	FORMAT OF RECORD	* D	AGENCY			REMARKS
										P	W	V	
1.13	HEMIHEAD	MT ON OUTER SURFACE AFTER FORMING	MAJOR	NDE	100%	ASME SEC.V ART.7	ASMASME SEC.VIII DIV.I , APPX.6	IR	✓	2	1		
1.14		DIM. CONFORMITY INCLUDING THICKNESS MEASURT. & OVALITY BY UT METHOD	MAJOR	MEASURT.	100 %	DRG.	DRG. & ASME SEC.VIII DIV.I	IR	✓	2	1		
1.15		LIFTING LUG ARRG T AND ORIENTATION	MAJOR	MEASURT.	100 %	DRG.	DRG.	IR	✓	2	1		
1.16		MT ON LIFTING LUG WELDS	MAJOR	NDE	100%	ASME SEC.V ART.7	ASMASME SEC.VIII DIV.I , APPX.6	IR	✓	2		1	
1.17		VERIFICATION OF TEST COUPON – C SEAM CHEM , MECH PROPERTIES	MAJOR	REVIEW	100%	SA 266 GR 2/ BHEL SPEC		IR	✓	2		1	
1.18		IDENTIFICATION & STAMPING - MAIN FORGING - TEST COUPON C SEAM	MAJOR	IDENTIFICATION & CORELATION	100%	DRG,SPEC. & QP	DRG.,SPEC & QP	SUPPLIER TC/IR	✓	2		1	
1.19		VERIFICATION OF TCS AS PER QAP, SPEC & PO - MAIN FORGING - TEST COUPON C SEAM - APPLICABLE IBR FORMS	MAJOR	REVIEW	100%	P.O., DRG. & SPN.	P.O., DRG. & SPN..	IR	✓	2		1	
2.0		HEMI HEAD MACHINING IF APPLICABLE AS PER PO											
2.1	HEMI HEAD MACHINING	DIM. CONFORMITY,VISUAL PRIOR TO MACHINING OPERATION	MAJOR	MEASURT. VISUAL	100%	DRG.	DRG.	IR	✓	2		1	
2.2		MACHINE CALIBRATION	MAJOR	REVIEW	100%	MFRS STD	MFR STD	CALIBRATION RECORD		2		1	

VENDOR TO SUBMIT DRAWING ANDTECH.DATASHEET FFOR BHEL APPROVAL.

LEGEND:

P: - PERFORM, W: - WITNESS, V: - VERIFICATION,

INDICATING 1: - BHEL / BHEL NOMMNATED INSPECTION AGENCY, 2: - VENDOR / SUB VENDOR 3 : CUSTOMER / CUSTOMER TPIA AS APPROPRIATE AGAINST EACH COMPONENT / CHARACTERISTICS UNDER THE COLUMNS P, W & V.

* D: RECORDS IDENTIFIED WITH TICK (✓) SHALL BE ESSENTIALLY INCLUDED IN QA DOCUMENTATION.

PREPARED BY:

ALOK BEHERA
MGR / QA

REVIEWED BY:

APPROVED BY:

T MUNIRAGHAVULU
AGM/QA



BHARAT HEAVY ELECTRICALS
LIMITED
R.C.PURAM, HYDERABAD

STANDARD QUALITY PLAN FOR VENDOR ITEMS
ITEM: SPECIFICATION FOR H.P. HEATER HEMIHEAD
FOR FEED WATER HEATERS
BHEL SPEC: HE 51546 REV AS PER PO
BHEL DRG : AS PER P.O.
PROJECT: ADANI PROJECTS

QP. NO: HYQA/VSQP/2024-25/HE 51546/ADANI
REV. NO. : 01
DATE: 29.10.2024
PAGE 3 OF 2

SL	COMPONENT & OPERATIONS	CHARACTERISTICS	CLASS	TYPE OF CHECK	QUANTUM OF CHECK	REF DOCUMENT	ACCEPTANCE NORMS	FORMAT OF RECORD	* D	AGENCY			REMARKS
										P	W	V	
2.3		MACINING OPERATION	MAJOR	VISUAL / DIMENSION	100%	MFR STD	MFR STD	IR		2			
2.4		FINAL VISUAL & DIMENSIONAL INSPECTION AFTER MACHINING - SIZE, POSITION ,OREINTATION	MAJOR	MEASURT. VISUAL	100%	DRG.	DRG.	IR	v	2	1		
2.5		MT ON THE MACHINED SURFACE – NOZZLE/MANWAY	MAJOR	NDE	100%	ASME SEC.V ART.7	ASME SEC.VI II DIV.I APPX.6	IR	v	2	1		
2.6		PT ON MACHINED SURFACE - NOZZLE/MANWAY - HEMI HEAD EDGE PREPARATION(C SEAM)	MAJOR	NDE	100%	ASME SEC.V ART.6	ASME SEC.VI II DIV.I , APPX.8	IR	v	2	1		
3.0	PRESERVATION & DESPATCH												
3.1		VERIFICATION OF COMPLETE QC DOCUMENTATION INCLUDING - IDENTIFICATION & MARKING/STAMPING - IBR FORMS AS PER SPECN. & QP	MAJOR	VISUAL	100%	DRG. , SPEC ,PO & QP	DRG. , SPEC ,PO & QP	SUPPLIER'S TC	v	2		1	
3.2		<ul style="list-style-type: none"> - TEMPORARY RUST PREVENTIVE SHALL BE APPLIED FOR PROTECTION DURING TRANSIT & STORAGE. - PRE-DESPATCH INSPECTION PHOTOGRAPHS OF THE EQUIPMENT/ITEM SHALL BE INCLUDED IN QUALITY DOCUMENTATION. 											

NOTE A : RAW MATERIAL SHALL BE SOURCED FROM BHEL APPROVED SOURCES ONLY.

NOTES FOR INSPECTOR - TPIA

1. TPIA TO CHECK THE LATEST VERSION OF STANDARDS/DRAWINGS /TOLERANCES ETC TO BE MENTIONED IN QUALITY PLAN/DRAWING. THIS QP SHOULD BE READ ALONG WITH BHEL SPEC, BHEL DRAWINGS / APPROVED DRAWINGS, DATA SHEET, BOM AND PO.
2. ONLY LEVEL II & ABOVE QUALIFIED PERSON IN RESPECTIVE NDE TO VERIFY OR WITNESS THE NDT TEST REPORT/RESULTS
3. INSPECTOR TO ENSURE THAT DOCUMENTS (QUALITY PLAN, DRAWINGS, DATA SHEET, PURCHASE SPECIFICATIONS, ETC) ARE AVAILABLE AS PER PURCHASE ORDER BEFORE STARTING THE INSPECTION.

<p>VENDOR TO SUBMIT DRAWING ANDTECH.DATASHEET FFOR BHEL APPROVAL. LEGEND: P: - PERFORM, W: - WITNESS , V: - VERIFICATION, INDICATING 1: - BHEL / BHEL NOMMNATED INSPECTION AGENCY, 2: - VENDOR / SUB VENDOR 3 : CUSTOMER / CUSTOMER TPIA AS APPROPRIATE AGAINST EACH COMPONENT / CHARACTERISTICS UNDER THE COLUMNS P, W & V. * D: RECORDS IDENTIFIED WITH TICK (✓) SHALL BE ESSENTIALLY INCLUDED IN QA DOCUMENTATION.</p>	<p>PREPARED BY: <i>Alok Behera</i> ALOK BEHERA MGR / QA</p>	<p>REVIEWED BY: <i>Kampan</i> VUSTELA SAMPATH KUMAR Sr. Manager Quality & Technical Excellence BHEL R&D Centre, Hyderabad</p>	<p>APPROVED BY: <i>T. Muniraghavulu</i> T MUNIRAGHAVULU AGM/QA</p>
---	--	--	---



BHARAT HEAVY ELECTRICALS
LIMITED
R.C.PURAM, HYDERABAD

STANDARD QUALITY PLAN FOR VENDOR ITEMS
ITEM: SPECIFICATION FOR H.P. HEATER HEMIHEAD
FOR FEED WATER HEATERS
BHEL SPEC: HE 51546 REV AS PER PO
BHEL DRG : AS PER P.O.
PROJECT: ADANI PROJECTS

QP. NO: HYQA/VSQP/2024-25/HE 51546/ADANI
REV. NO. : 01
DATE: 29.10.2024
PAGE 4 OF 2

SL	COMPONENT & OPERATIONS	CHARACTERISTICS	CLASS	TYPE OF CHECK	QUANTUM OF CHECK	REF DOCUMENT	ACCEPTANCE NORMS	FORMAT OF RECORD	* D	AGENCY			REMARKS
										P	W	V	

4. TPIA TO REVIEW ONLY THE ORIGINAL TEST CERTIFICATES ISSUED BY THIRD PARTY LABORATORIES OR SUPPLIERS.
5. INSPECTION REPORTS SHALL BE SUBMITTED WITH A REMARK THAT ' COMPARED WITH ORIGINAL TEST CERTIFICATE. REVIEWED, VERIFIED AND FOUND IN ORDER '. TPIA TO ENSURE THE SAME.
6. INSPECTOR TO ENSURE USE OF VALID AND CALIBRATED MEASURING INSTRUMENTS AND EQUIPMENT.
7. TPIA SHALL ENSURE THAT MATERIAL TEST CERTIFICATE & TRACEABILITY RECORDS ARE AVAILABLE FOR USE OF CORRECT MATERIAL
8. QUALIFICATION OF EQUIPMENT, PROCESS & PERSONNEL FOR SPECIAL PROCESSES LIKE WELDING, BRAZING, PAINTING & METAL COATING ETC.
9. TPIA TO ENDORSE ON ALL CERTIFICATES WITH COMMENTS (WITNESSED OR VERIFIED) AS PER QUALITY PLAN
10. TPIA SHALL ENSURE THAT LOG SHEETS CONTAIN ACTUAL MEASURED VALUES INSTEAD OF SAYING OK/NOT OK.
11. COMPLETE INSPECTION AND TEST DOCUMENTATION WHICHEVER IS IDENTIFIED WITH (v) UNDER COLUMN D OF APPROVED QUALITY PLAN SHALL BE ENCLOSED WITH THE INSPECTION REPORT. ALL TEST CERTIFICATES/ REPORTS REVIEWED AND CERTIFIED BY BHEL/TPI SHALL BE SUBMITTED TO BHEL AS DOCUMENTATION PACKAGE
12. ORIGINAL COPIES OF ALL INSPECTION AND TEST DOCUMENTS AUTHENTICATED BY TPIA SHALL BE SUBMITTED.

GENERAL NOTES

- BHEL RESERVES THE RIGHT FOR CONDUCTING REPEAT TEST, IF REQUIRED.
- BHEL APPROVED INSPECTION ENGINEERS TO BE DEPLOYED FOR INSPECTION.
- DRAWING / DATA SHEET SHALL PREVAIL OVER QUALITY PLAN IN CASE OF ANY CONTRADICTION BETWEEN QUALITY PLAN AND DRAWING / DATA SHEET.
- ALL TEST REPORTS SHALL BE PROVIDED AS PER PRESCRIBED FORMATS IN BHEL SPEC.
- ANY OTHER TESTS/ CHECKS INDICATED IN SPECIFICATION, P.O., OR DRAWING & ANY ADDITIONAL CHECKS ENVISAGED BY BHEL/TPI TO ENSURE WORKMANSHIP, FINISH, AESTHETICS, ETC. SHALL ALSO BE CONDUCTED AND WITNESSED/VERIFIED BY BHEL /TPI / CUSTOMER AS REQUIRED

MTC – MILL TEST CERTIFICATE

TC – TEST CERTIFICATE

IR – INSPECTION REPORT

COC – CERTIFICATE OF CONFORMITY

TPIA – THIRD PARTY INSPECTION AGENCY APPOINTED BY BHEL.

PO – PURCHASE ORDER

MPS – MANUFACTURING PROCESS SHEET

HTP - HEAT TREATMENT PROCEDURE

WPS- WELDING PROCESS SPECIFICATION

PQR- PROCESS QUALIFICATION RECORD

WQR- WELDER'S QUALIFICATION RECORD

RP - REPAIR PROCEDURE

SP – STORAGE PROCEDURE OF WELDING CONSUMABLE

FCR – FURNACE CALIBRATION RECORD/REPORT

ICR – MEASURING INSTRUMENT CALIBRATION RECORD/REPORT

NDE - NON DESTRUCTIVE EXAMINATION

VENDOR TO SUBMIT DRAWING AND TECH.DATASHEET FOR BHEL APPROVAL.

LEGEND:

P: - PERFORM, W: - WITNESS, V: - VERIFICATION,

INDICATING 1: - BHEL / BHEL NOMINATED INSPECTION AGENCY, 2: - VENDOR / SUB VENDOR 3 : CUSTOMER / CUSTOMER TPIA AS APPROPRIATE AGAINST EACH COMPONENT / CHARACTERISTICS UNDER THE COLUMNS P, W & V.

* D: RECORDS IDENTIFIED WITH TICK (✓) SHALL BE ESSENTIALLY INCLUDED IN QA DOCUMENTATION.

PREPARED BY:

ALOK BEHERA
MGR / QA

REVIEWED BY:



APPROVED BY:

T. MUNIRAGHAVULU
AGM/QA

PRE-QUALIFICATION CRITERIA

CS Hemihead Forging for High Pressure Feed Water Heater Application

S.No.	BHEL Requirement	Vendor's Confirmation	Deviation if Any	Remarks
1	All the suppliers need to submit this document i.e. titled pre-qualification criteria and furnish required information along with offer.			
2	<p>a) Name, address, e-mail id, contact no. etc. of Hemi head manufacturer.</p> <p>b) Name, address, e-mail id, contact no.etc. of authorised agency / trading house quoting on behalf of manufacturing mill. In case offer is received from authorised agency / trading house, the following requirements shall be full filled.</p> <p>i) Valid letter of authorisation and copy of agreement to be enclosed with offer.</p> <p>ii) The offer should be either from the authorised agency or from the manufacturer directly. In case of BHEL receiving offer from both, then offer from manufacturer will only be considered. Offer from an unauthorised agency / entity on behalf of any vendor shall be summarily rejected.</p> <p>iii) Name, address, e-mail id, contact no.etc. of entity on whom order to be released in case of L1 shall be clearly indicated.</p>			
3	<p>Supplier to confirm/provide the following criteria/documents for evaluation of offer.</p> <p>(a) The supplier should have the proven experience in manufacturing and supply of Hemi Heads to reputed companies for Heat Exchangers as mentioned below.</p> <p>i) Material : SA 516 / SA 515 / SA 266 Gr.1-4 / SA 299 confirming to ASME BPVC SEC-II PART-A. Materials supplied as per standards equivalent to above ASME Materials can be considered. However it is vendors responsibility to provide sufficient document evidence to prove the equivalent standard for ASME Materials.</p> <p>ii) Hemi Head I.D.: 1200mm minimum and above.</p> <p>iii) Hemi Head Thickness: 100 mm minimum and above.</p> <p>iv) Application: High Pressure Feed water heater (HP Heater)/Steam Boiler Drum in a powerplant/Any Heat Exchanger</p> <p>v) Service: Thermal power plant/Nuclear power plant/process industry</p> <p>vi) Satisfactory Working of equipment: The heat exchanger provided with this hemi heads should have undergone successful hydro test either at heat exchanger manufactures works or at site (where the exchanger is installed) ending last day of the month previous to the one in which enquiry is floated.</p> <p>All the above criteria 3(a) (i) to 3(a) (vi) must be combinedly met by the vendor against a single supply reference of Hemi head.</p> <p>Supplier's having experience in other materials, I.D., thickness and application will not be treated as proven experience.</p> <p>(b)(i) The supplier meeting all the above criteria as 3 (a) (i) to 3 (a) (vi) shall furnish the following details in Annexure - 1.</p> <ul style="list-style-type: none"> - Contact details of Heat exchanger Manufacturer (Name, e-mail ID, Mobile etc) - Date of Hemihead supply (DDMMYY format) - Quantity, size - Date of Hydro Test - Power Plant Name / Site name - No of years equipment is in service. <p>Or</p> <p>Heat exchanger manufacturer's certificate (in English) containing the supply details as above both 3(a) & 3 (b)(i), Contact details [E-Mail ID, Land line/Mobile No.] and complete address of Heat exchanger Manufacturer may be furnished.</p> <p>Note : Suppliers shall furnish minimum of one reference and maximum upto 06 numbers of latest references meeting the above criteria in Annexure - 1</p> <p>All the documents shall be furnished only in English. Documents furnished in other langauges will not be considered for further evaluation.</p> <p>(c) BHEL reserves the right to cross verify with the above such customers and satisfy itself with reference to the claims of the supplier. If the information furnished by the supplier is not found satisfactory / no response from customer, the offer will be technically rejected.</p>			
4	Offers without the requirement as above 3(a) & 3(b) will not be technically evaluated by BHEL. Further, no correspondence in this matter will be entertained.			
5	If the Hemihead manufacturer is not having a facilities to forge a blank to the required diameter and thickness, then the raw forged blank is to be sourced from reputed forge masters. The Hemihead manufacturer shall furnish details of such forge masters along with manufacturing and testing facilities, size ranges and the customers to whom they are supplying. BHEL will review the credentials of such supplier and may accept the proposal if it is satisfied technically. The decision of BHEL /End customer is final in this regard.			
6	The vendors should furnish the detailed process of manufacturing and testing procedures along with the offer.			
7	List of BHEL qualified bidders may be forwarded to BHEL's End Customer for their review and approval. The list finalized by BHEL's End Customer in such case shall be final and binding.			
8	BHEL team may carry out vendor evaluation/assesment(incase of a new vendor)by a visit to vendor works for qualifying /rejecting the technical bid based on the findings of the visit.			
9	Vendors to submit their bid in 2- part system, i.e. Part-I shall consists of Pre-Qualification Criteria along with the required documnets and Techno-commercial bids and Part-II shall consists of Price Bid. Offers failing to meet prequalification part will not be considered for further evaluation.			

Hemihead Reference details													
Ref project S.no	Material (SA 516 / SA 515/ SA 266 Gr.1-4 / SA 299)	ID mm	THK (min 100) mm	Supply date DDMMYYYY	HP Heater/Steam Boiler drum Application	Heater manufacturer details			End customer details				
						Supplied to (Heater/Steam Boiler Drum Manufacturer's name)	Contact person	E-Mail id &Phone no	Name of the organisation(End user)	Project Details Name: MW Rating: Location	No.of years the equipment is in service	Contact person	E-Mail id&Phone no:
1													
2													
3													
4													
5													
6													

Note:

- Reference list shall be submitted in the above format only.
- Vendors are requested to fill the above and submit along with PreQualification Criteria(PQC).Details mentioned above only are considered for PQC evaluation.
- wherever details are not available,vendor to mention as "NA"
- Reference project Hemihead/Steam boiler drum shall be either of SA 516 /SA 515/ SA 266 Gr.1-4 / SA 299 conforming to ASME BPVC.SEC-II PART-A. Materials supplied as per standards equivalent to the said ASME Materials can be considered.However it is vendors responsibility to provide sufficient document evidence to prove the equivalent standard for ASME Materials. Other materials shall be considered as INVALID Reference.
- Reference project Hemihead/Steam Boiler drum ID shall be of 1200 mm(Minimum).
- Reference project Hemihead/Steam Boiler drum thickness shall be 100 mm(min) Thickness less than 100 mm(min) shall be considered as INVALID Reference.
- Clause no 3(a) (i) to 3(a) (vi) of PQC must be combinedly met by the vendor against a single supply reference of Hemihead. Maximum of 06 such reference shall be mentioned in the above table.

SPECIAL CONDITIONS OF CONTRACT (SCC)

S. NO.	ITB Clause No.	TERMS & CONDITIONS	BHEL REQUIREMENT	VENDOR 'S CONFIRMATION / REPLY
I TECHNICAL TERMS				
1		DESCRIPTION, SIZE & QUANTITY	Package-1 HEMIHEAD FORGING(HE9712844250) Qty. 6 Nos TEST COUPON FOR HEMIHEAD(HE9712844269) Qty. 6 Nos Package-2 HEMIHEAD FORGING(HE9712844277) Qty. 42 Nos TEST COUPON FOR HEMIHEAD FORGING(HE9712844285)Qty. 42 Nos Package-3 HEMIHEAD FORGING(ID1303 X 150THK)(HE9712844293)Qty. 14 Nos TEST COUPON FOR HEMIHEAD FORGING(HE9712844307)Qty. 14 Nos	
1a		Pre Qualification Criteria (PQC)	Refer Annexure Prequalification Criteria (Filled supply refernce required)	
2		PRODUCT SPECIFICATION	HE51546 REV 01 All clauses of the specification must be strictly adhered to.	
3		MATERIAL SPECIFICATION	Applicable Drawings and Product specification ASME SEC II PART A 2023 EDITION SHALL BE FOLLOWED.	
4		DRAWING	DRAWING NO : 41750103637 REV 00 41750103663 REV 00 41750103667 REV 00	
5		QUALITY PLAN	QAP No. HYQA/VSQP/2024-25/HE51546 Rev.01	
6	36	INSPECTION & CERTIFICATION	By BHEL TPIA and IBR as per Quality Plan and CIB in IBR Form-III I Note: (i)Vendors are advised to raise Inspection Call in CQIR system (www.cqir.bhel.in) with Purchasing Unit as 'HPEP' at least 5 working days prior to the proposed date of inspection (refer Annexure-I for timelines). (ii) Advance intimation of 1 week shall be provided for arranging customer inspection.	
II COMMERCIAL TERMS				
1	3	Mode of Submission	E-Procurement (thru' NIC portal). Note: Offer submitted in any other mode shall not be considered.	
2	6	Indigenous Purchase - Destination	FOR BHEL RC Puram Stores for Indian Vendors. Freight & Insurance up to destination is in vendor scope.	
3		THIRD PARTY INSPECTION & CERTIFICATION CHARGES	BHEL TPI inspection charges by BHEL. Vendor's offer will be loaded by appropriate percentage for evaluation. Currently it is 0.174%.	
4		CIB Charges / Certification in IBR Form - III I	Shall be inclusive in quoted price.	
5	10	Price Validity	90 Days from Part-I bid opening date.	
6		Tender Cost	Not Applicable	
7	12	Earnest Money Deposit	Not Applicable	
8	8	DELIVERY PERIOD	Refer Delivery schedule Annexure-D0 Note:Delivery quoted beyond required delivery period will attract loading of 0.5% per week for evaluation of offer. However, BHEL reserves the right to reject the offers with delivery period not meeting the project stipulated delivery schedule.	
9	5	Type of bid	Offer shall be submitted in 2-Part bid with Part-1 consists of Techno-commercial bid and Part-2 consists of Price bid.	
10		Techno-Commercial Bid	Techno-Commercial Bid shall essentially consist of: (i) Signed and Stamped copies of Product Spec. Drawings and Duly filled in signed and stamped Special Contract Conditions (SCC) & PRE-QUALIFICATION CRITERIA. (ii) Duly filled in signed and stamped Instructions to Bidder (ITB) along with applicable Annexures mentioned therein (Annexure-I,II,III,IV). (iii) Udyam Registration Certificate for MSE vendors Note: Bid shall be complete in all respects including all the documents / information required for techno-commercial evaluation. Incomplete offers shall be liable to rejection.	
11		Price Bid	Quoted price shall be firm basis. Vendor shall quote rate per piece.	
12	18	Evaluation Basis	Packagewise Lowest destination cost to BHEL Basis.	For Information
13	9	Price Variation Clause	Not Applicable	For Information
14	Others	Quantity Split	Applicable. In case of 2 or more techno commercially qualified bidders Distribution shall be in following ratio , i)Package-1 and Package-2 in the ratio: 2:1 and ii) For package 3 as 4:3 L1 price will be counter-offered to other bidders in the order of ranking upto Ln-1 bidder (where n>2) or up to L2 bidder in case of only 2 qualified bids. The bidder who accepts the counter offer shall be awarded the corresponding quantity and balance quantity, if any, shall be counter offered to the next ranked bidders. In case of non-acceptance of counter offer or any quantity remaining after acceptance of a counter offer,the corresponding quantity will be ordered on L1 bidder.	For Information
16	Others	Contract Execution Bank Guarantee	Not Applicable	

SPECIAL CONDITIONS OF CONTRACT (SCC)

S. NO.	ITB Clause No.	TERMS & CONDITIONS	BHEL REQUIREMENT	VENDOR 'S CONFIRMATION / REPLY
17	17	Performance Bank Guarantee	Not Applicable	
18	7	Additional Documentation for Payment	- MTC, CQIR along with Internal TCs and Customer inspection report as per approved QAP. - Guarantee Certificate	
19	13	Maximum Penalty Applicable on	Undelivered Portion of Order Value.	
20	16	GUARANTEE	Guarantee on the supplier for a period of 18 months from the date of dispatch or 12 months from the date of commissioning whichever is earlier.	
21		REVERSE AUCTION	<p>"BHEL shall be resorting to Reverse Auction (RA) (Guidelines as available on www.bhel.com) for this tender. RA shall be conducted among the technocommercially qualified bidders. Details of vendor's Representative participating in RA like :-</p> <p>1. Name:-</p> <p>2. E-mail:-</p> <p>3. Phone :-</p> <p>Price bids of all techno-commercially qualified bidders shall be opened and same shall be considered for RA. In case any bidder(s) do(es) not participate in online Reverse Auction, their sealed envelope price bid along with applicable loading, if any, shall be considered for ranking."</p>	
22		Integrity Pact	<p>(a) IP is a tool to ensure that activities and transactions between the Company and its Bidders / Contractors are handled in a fair, transparent and corruption free manner.</p> <p>(b) In case of any complaint arising out of the tendering process, the matter may be referred to any of the below e-mail IDs: iem1@bhel.in iem2@bhel.in iem3@bhel.in</p> <p>As on date, the positions of Independent External Monitors (IEMs) are vacant in the Company. As and when the IEMs join based on due approval of the Competent Authority, any complaint(s) received will be shared with the IEMs.</p> <p>(c) The IP as enclosed with the tender is to be submitted (duly signed by authorized signatory) along with techno-commercial bid (Part-I, in case of two/ three part bid). Only those bidders who have entered into such an IP with BHEL would be competent to participate in the bidding. In other words, entering into this Pact would be a preliminary qualification.</p>	
23	Others	Customer Approval of Vendor	Not Applicable.	
24	Others	QAP Approval	Not Applicable.	
25	Others	Financial / Commercial PQC	<p>The minimum average Financial turnover of the supplier during last 3 financial years should not be less than Rs. 75lacs.</p> <p>Vendor shall submit last three years Audited Financial statements of Balance sheet & Profit & Loss statement.</p>	
26		TERMS & CONDITIONS	Vendor is requested to furnish all details of the offer in this format. In case of any discrepancy between information furnished here and those furnished elsewhere in the bid, the information furnished in this document only shall be considered, and those furnished else where shall be ignored.	

Annexure-D0

Delivery time	Hemihead	Qty. of Hemihead
6Months from PO date	HEMIHEAD FORGING(HE9712844277)& Test coupon	6
	HEMIHEAD FORGING(ID1303 X 150THK)(HE9712844293)& Test coupon	2
7Months from PO date	HEMIHEAD FORGING(HE9712844277)& Test coupon	6
	HEMIHEAD FORGING(ID1303 X 150THK)(HE9712844293)& Test coupon	2
8Months from PO date	HEMIHEAD FORGING(HE9712844277)& Test coupon	6
	HEMIHEAD FORGING(ID1303 X 150THK)(HE9712844293)& Test coupon	2
9Months from PO date	HEMIHEAD FORGING(HE9712844277)& Test coupon	12
	HEMIHEAD FORGING(ID1303 X 150THK)(HE9712844293)& Test coupon	4
10Months from PO date	HEMIHEAD FORGING(HE9712844277)& Test coupon	12
	HEMIHEAD FORGING(ID1303 X 150THK)(HE9712844293)& Test coupon	4
11Months from PO date	HEMIHEAD FORGING(HE9712844250)& Test coupon	6



(Attachment to Enquiry No. XXXXXXXXXX Due on Date XX.XX.XXXX for submission by 11.00 hrs to open from 14.00 hrs.)

INSTRUCTIONS TO BIDDER (ITB)**NOTE: Bidder to confirm in affirmative by typing "YES" or "Applicable Data" in the response column. Deviations, if any shall be recorded in deviations/comments column (Separate sheet can be attached if needed). Non deviatable clauses are indicated as "NON DEVIATABLE".**

Sl. No.	DETAILED TERMS & CONDITIONS	BIDDER RESPONSE (YES/NO)	DEVIATIONS / COMMENT
1	SCOPE OF SUPPLY:		
	Signed & Sealed offers are invited for the Scope of Supply of goods or services or both as detailed in the enquiry. Relevant enclosures/supporting documents / catalogue, if any shall be enclosed to the technical offer.		
2	DEFINITIONS		
A	'The Buyer' means BHEL-HPEP, Ramachandrapuram, Hyderabad-502 032 of Bharat Heavy Electricals Limited (A Govt. of India Undertaking) incorporated under the companies Act having its registered office at BHEL House, Siri fort, New Delhi-110049, India and shall be deemed to include its successors and assigns. It may also be referred to as BHEL.		
B	'The Bidder' means the persons, firm, company or organization on whom the Purchase order is placed and shall be deemed to include the bidder's successors, representatives, heirs, executors and administrator as the case may be. It may also be referred to as Contractor, supplier or bidder.		
C	'Contract' shall mean and include the Purchase order incorporating various documents viz., Notice Inviting Tender (NIT), Offer, Letter Of Intent/Acceptance (LOI/LOA), Instruction to Bidders (ITB) and Special Conditions of Contract (SCC), specifications, inspection/quality plan, schedule of prices and quantities, drawings, if any, enclosed by Bidder/ provided by the Buyer or his authorized nominee and the samples or patterns if any to be provided under the provision of the contract. In case of any inconsistency or contradiction between any of the documents, the order of precedence shall be Purchase Order, LOI/LOA followed by Minutes Of Meeting (MOM), NIT, SCC, ITB.		
D	'Parties to the contract' shall mean the bidder and the buyer as named in the main body of the Purchase Order.		
E	'Goods/Material' shall include Works and Services which are incidental or consequential to supply.		
3	GENERAL INSTRUCTIONS:		
A	Mode of submission of offer shall be as indicated in SCC		Non Deviatable
B	The quotation should be neatly typed and free from over writing/ erasures. Any correction or addition must be authenticated. The offer including annexures and brochures should be submitted in English / Hindi. All Pages of Techno Commercial Bids (Main Pages), ITB, SCC should be signed and Stamped. If there is a conflict in case of bilingual submission, the submission in English will be final. Prices shall be quoted both in figures and words. In case of any discrepancy in value, the prices quoted in words shall be considered for evaluation and establishing L1 Status. Any discount / revised offer / bids submitted by a bidder on his own shall be considered, provided it is received on or before the due date and time of offer / bid submission (Part-1). Conditional discounts shall not be considered for evaluation of tenders.		Non Deviatable
C	Incomplete offers are liable for rejection.		Non Deviatable
D	Bidders to please note that the Terms & conditions contained in this document and SCC are to be read fully before submission of quotations.		Non Deviatable
E	Bidders are advised to comply with ITB and SCC, should there be any deviations (where deviations are permitted), it shall be entered in the deviation column. BHEL reserves the right to reject such offers or load the bid suitably for evaluation.		Non Deviatable
F	Offers shall be submitted directly, only by the bidder or by their authorized representative / agent and the offer should be in line with the regulatory guidelines (i.e. A valid Agency agreement between principal bidder and agent / representative shall be attached and the agreement shall cover the scope of services rendered by Agent, Agency Commission and any other information called for as per the regulatory guidelines). OEM / Mill details shall be provided if bidder is not a manufacturer. Bid envelops shall bear the name of Bidder. In case of submission through authorized representative/agent, the name of representative/agent should also be mentioned apart from bidder name.		Non Deviatable
G	Offer received after the specified time and date of submission will be rejected. No further correspondence shall be entertained.		Non Deviatable
H	Unsolicited offers will not be considered.		Non Deviatable
4	OTHER PARTICULARS (Please indicate applicable data)		
A	Name of the Bid currency (freely tradable foreign currency for imports and Indian Rupees for indigenous purchase).		
B	Name of the Port of loading and Port of Discharge (applicable to imports).		

5	BID SUBMISSION PROCEDURE FOR CONVENTIONAL TENDER:		
A	For Single Part Bids:		
	The complete bid shall be submitted in a single sealed cover superscribing the Tender number and due date, addressed to Sr DGM/CMM, Vendor Complex, BHEL, Hyderabad and sent by appropriate mode to above address or dropped in tender box located at vendor complex on or before the specified time and date of submission of offers, preferably in the bidder's envelope. E- mail bids shall be sent to mail ID pricebid_hyd@bhel.in only as an attachment.		Non Deviatable
B.	For two-Part Bids:		
i	<p>The offer is to be submitted in two parts viz., Techno-commercial Bid - (Part-I), with all technical specification & scope including bill of material etc., Earnest Money Deposit (EMD)(wherever applicable) and unpriced bid with all applicable Commercial Terms and Conditions, rates of agency commission, duties, taxes and other charges, Signed and Stamped ITB and SCC, <u>except the price</u>, shall be kept in a separate sealed cover, superscribing enquiry No. (Techno-Commercial Bid) and due date AND Price Bid (Part-II), containing ONLY the price (including agency commission, if any) and the applicable duties/taxes/other charges shall be kept in a separate sealed cover superscribing Enquiry no. (Price bid) & due date.</p> <p>Both the above covers (Part –I & II) shall be kept in a Third cover superscribing Enquiry no. & due date.</p> <p>Bidder can also submit offer through email. Technical offer to be submitted to mail ID technicalbid_hyd@bhel.in, and price bid to be submitted to mail ID pricebid_hyd@bhel.in only as an attachment. Interchanging the information in the mails may lead to rejection of the offer. Bidder shall have no claim on e-mail offers sent to any other e-mail ID.</p> <p>In case of e-mail offers, the mail subject should contain Enquiry Number, Due date and Bidder name. Bidder address including contact details shall be mentioned in the content of the mail. Without these details, the offer is liable for rejection.</p> <p>All techno commercial terms & conditions mutually agreed prior to price bid opening shall prevail and supersede any terms and conditions specified otherwise in price bid.</p>		Non Deviatable
ii	The bidders whose bids are techno commercially not accepted will be informed and EMD shall be returned wherever submitted.		
iii	Bidders will be allowed to submit the impact on their quoted prices due to changes in technical scope, specifications, and commercial terms/conditions as specified in NIT which in the opinion of BHEL , warrant changes in prices.		Non Deviatable
C	Bids shall be opened on due time and date in the presence of bidders who may like to be present. Only one representative of each bidder shall be permitted to attend the bid opening. Only the price bids of bidder (in case of two part bid) whose techno commercial bids are accepted will be opened later on a specified date.		Non Deviatable
6	DELIVERY TERMS		
A	Indigenous Purchase		
	a. Terms of Delivery for dispatches to BHEL Hyderabad (HPEP) shall be FOR Destination. b. Terms of Delivery for Direct Dispatch (DD) items shall be Ex Works. i. In case specified in SCC that insurance is in customer/BHEL scope, price quoted shall include Freight charges up to Destination. ii. Otherwise, price quoted shall include Freight and Insurance upto Destination. However, beneficiary for insurance shall be BHEL.		
B.	Imports		
	The goods shall be delivered on FCA capital airport basis in case of freight by Air and CIP basis in case of freight by Sea.		
7	Documentation for Payment		
A	Indigenous Purchase		
	Following documents shall be submitted immediately on dispatch of material to BHEL HPEP / Site a. Two numbers of Original Tax Invoice (Refer ITB clause no 11 for Tax Compliance)/ e-invoice of GST Portal if applicable) b. Packing List - clearly showing number of packages, gross weight and net weight. c. Test/Warranty/Guarantee certificates, O&M Manual (If specified in SCC) d. Insurance intimation/declaration certificate e. Pre-dispatch Inspection report /Third Party Inspection Certificates. f. Consignee copy of LR signed & stamped by Customer/Site representative for DD Items g. e-waybill h. Any other documents as specified in SCC.		Non Deviatable



B	<p>Softcopies of the above documents shall be uploaded in SUVIDHA portal https://suvidha.bhel.in/suvidha/ or https://hpep.bhel.com/mm/main.jsp Vendor Bills tab. immediately after dispatch of the material. Upload of Documents is mandatory for material Entry.</p> <p>Imports</p> <p>i) Bidder shall inform BHEL the readiness of material along with packing details 30 days in advance from the date of delivery. For Hazardous cargo/DG cargo, supplier must provide the following documents prior to handing over shipment to freight forwarder, wherever freight is in BHEL scope:</p> <ol style="list-style-type: none">1. Valid MSDS2. DGD certificate with appropriate UN numbers.3. Labelling and marking on DG cargo along with photo of packaging.4. Self-declaration for consignment5. Packaging Certificate as per DG Standards6. TSA Approved Truckers details to be provided to forwarder at the time of shipment <p>In addition to the above, supplier should ensure to comply all IATA DG regulations, if any new requirement is added in future.</p> <p>ii). Bidder shall also upload the soft copy of the dispatch documents consisting of BL / AWB, Invoice, delivery note, packing list, country of origin & Test certificates and other documents as specifically indicated in the SCC in PRADAN Portal (https://hpep.bhel.com/mm) within Five days from the B/L date for sea shipment and One day from AWB date for Air shipment and sent to email ids: mssea@bhel.in, msair@bhel.in, cmmfe@bhel.in.</p> <p>iii) AWB/BL must contain the information of BHEL GST no., and PAN no.</p> <p>iv) Air Shipments: Bidder shall ensure the following</p> <ol style="list-style-type: none">a) Port of discharge -- Mumbai/Chennai/Hyderabad (as indicated in SCC).b) Consignee shall be BHEL, Hyderabad. Material shall be air freighted through cargo mode only and not through Courier.c) Upon handing over the cargo to the forwarder, bidder shall ensure the acknowledgement receipt with wordings "Cargo handed over in sound condition for Air freighting". Note: Warehouse receipt will not be considered for penalty calculations.d) In case of CIF/ shipments, bidder shall also inform BHEL the information about discharge port agent details and cargo arrival information within one day from the date of Shipment.e) Following dimensions of single package may be noted.<ol style="list-style-type: none">i). Maximum dimension of the cargo(ODC) -- 125" x 88" x 63"ii). Maximum weight of the cargo -- 3.5 MT.If any package dimension or weight exceeds the above set limits, it will be treated as Over Dimension Cargo (ODC) or Over Weight Cargo and bidder shall inform BHEL 30 days in advance to the delivery date to enable BHEL to finalize the freight forwarder.f). If package falls under Hazardous category, bidder shall communicate BHEL 30 days in advance period with document support. <p>v) Sea Shipments:- bidder shall ensure the following</p> <ol style="list-style-type: none">a). Port of discharge -- Nhavaseva/Mumbai/Chennai.b). Place of Delivery / Final Destination for CIP shipments - Nhavaseva CFS / Chennai CFS.c). In case of FOB shipments, bidder shall handover the material to BHEL nominated forwarder and obtain the cargo receipt.d). If the material cannot be containerized in 20 or 40 GP containers, an advance information of 30 days prior to the delivery date shall be communicated to BHEL for necessary arrangements and finalisation of freight forwarder.e). For CIP shipments<ol style="list-style-type: none">1. In case of FCL shipments, Detention free period must be 14 days.2. Bidder shall also inform BHEL the information about discharge port agent details and cargo arrival information within 5 days from the date of Shipment.3. No charges for the services rendered till place of destination will be payable by BHEL. In case liner / forwarder insist for charges, not in the scope of BHEL, the same will be adjusted from bidder account.4. In case of CIF shipments -- Bidder must select a forwarder/liner whose discharge port published tariff for THC and other services is available. Any charges over and above the published tariff will not be borne by BHEL or will be adjusted from the bidder's bill.5. bidder must insure the cargo for 110% of material value including the freight amount. <p>(vi). Recovery charges for non-submission of documents: - Bidder shall submit all the required documents to BHEL as prescribed in the Purchase order and NIT.</p>		
---	--	--	--



If BHEL incurs any charges such as Penalty, demurrage, container detention, wharfage, storage, Ground rent etc., due to non - compliance / non - submission of documents prescribed in Purchase Order/ NIT/Letter of credit, the same shall be recovered from the bidder as under:
 1. EUROPE/USA/Black Sea/ Far East/Middle East/South East sector

A. For FOB Sea Consignments:-

Penalty for late submission / negotiation of documents beyond 14 days shall be as under:

Sl. no	Period (From Date of Bill of Lading)	Recoverable Charges	Recoverable Charges per day per container	
		LCL per week/ Break bulk cargo per day	20FT Container	40FT Container
i	Upto 14th day	Nil	Nil	Nil
ii	15th day onward	USD 10	USD 110	USD 200

B. For CIP Sea Shipments: -

Bidder shall provide rates for detention charges after free period at the time of offer itself in case of engagement of 20FT Container and 40FT category. In case of late presentation of documents to the bank recovery will be effected from the Bidder as per the rates quoted by the Bidder at the time of offer in this regard.

In case of Break bulk cargo and LCL, Demurrage charges shall be recovered at the rate of USD 1 per Ton per day and storage charges at the rate of USD 10 per week respectively shall be charged as late presentation charges.

(vii) Description of items in invoice, packing list, BL / AWB or LR shall be same as PO item description. Bidders shall ensure that invoice shall contain PAN nos. of both bidder and BHEL along with other tax related numbers. BHEL PAN AAACB4146P and BHEL TAN HYDB00086C Any other additional documents sought by the statutory authorities, the same shall be produced by the bidder on priority basis.

(viii) Bidder shall provide package details including number of packages, gross weight, net weight etc.

(ix) The bidder shall provide the following documents at the time of submission of offer:

a) No Business Connection in India declaration issued by the bidder as per the format specified. (or)

b) (i) No Permanent Establishment in India declaration issued by the bidder as per the format specified.

(ii) Tax Residence Certificate issued by the bidder's tax authorities.

(iii) Form 10F, as attached in Annexure V, to be issued by the bidder.

c) In case the bidder has a Business Connection in India as per Section 9 of Income Tax Act or significant economic presence in India as per rule 11 UD of IT Act or Permanent Establishment in India as per Article 5 of Double Taxation Avoidance Agreement between India and the bidder's country, the bidder shall provide a withholding tax order issued by the Indian Income Tax authority for recovery of applicable tax.

8	Delivery Schedule		
	The tendered goods shall be delivered within the period stipulated in NIT/ SCC as accepted. Inordinate delay/early supply are liable for rejection/ Hold on payment.		Non Deviatable
9	Pricing Terms		
	Quoted price shall be inclusive of Packing & Forwarding and shall remain firm and valid during the execution of PO. Offers with PVC will be rejected outright except in cases where specifically called for in the SCC.		Non Deviatable
10	PRICE VALIDITY :		
	Unless otherwise specified, offer shall be valid for a period of 90 days from the date of bid opening (Technical bid /part-I in case of two part bid). However the prices quoted for spare parts of the Main equipment shall be kept valid for a period as specified in SCC.		Non Deviatable

<p>11</p> <p>A</p>	<p>Taxes & Duties (RATE TO BE INDICATED by the bidder against the space provided)</p> <p>Indigenous Purchase</p> <p>i) Only valid GST registered bidders will be considered for the tender. The GSTIN of the bidder should be clearly mentioned in the offer.</p> <p>ii) If bidder is exempted from GST registration under any provision of the GST Law, a declaration with due supporting documents should be furnished for considering the offer.</p> <p>iii) Bidder to quote the applicable taxes in the following manner:</p> <ul style="list-style-type: none"> - Harmonized System of Nomenclature (HSN) of Goods - Services Accounting Code(SAC) of Services. - IGST/CGST/SGST/UTGST: Rate of Tax to be quoted as extra in % against the space provided <p>iv) Bidders to ensure correct applicability of IGST/CGST/SGST/UTGST based on the Inter / Intra state movement of goods/services.</p> <p>v) In case Bidder has opted for GST Composition Scheme, the same may be stated explicitly both in their technical and price bids. An undertaking to the effect that any change in the status of the bidder will be intimated.</p> <p>vi) Any other taxes & duties not covered anywhere above may be indicated separately.</p> <p>Taxes deducted at source:</p> <ul style="list-style-type: none"> - TDS as per the extant statutes shall be deducted. - In case bidder does not provide PAN details, higher rate of tax shall be deducted as per the Act. - Concessional certificates, if any, should be provided well in time for lower deduction of tax. 	<p>Non Deviatable</p>
	<p>Terms & Conditions to be complied</p> <p>1. All invoices (incl. Credit Notes, Debit Notes) to contain BHEL HPEP GSTIN ie 36AAACB4146P1ZG. Invoices submitted should be in the format as specified under GST Law. All details as mentioned in Invoice Rules including Dealer GST registration number (GSTIN), invoice number with date of issue, quantity, rate, value, taxes with nomenclature – CGST, SGST, UGST, IGST mentioned separately, HSN Code / SAC Code etc.</p> <p>2. Reimbursement of GST amount will be made only upon completion of the following:</p> <ol style="list-style-type: none"> i. Bidder declaring such invoice in their GSTR-1 Return/ IFF ii. Receipt of Goods or Services and Submission of Tax invoice by BHEL iii. The tax invoice is reflected in the GSTR2B of BHEL, HPEP (buyer). Payment of GST will be made only if it is matching with data uploaded by the Bidder in GST portal. <p>3. In case of discrepancy in the data uploaded by the bidder in the GSTN portal vis-a-vis the tax invoice or in case of any shortages or rejection in the supply, then BHEL will not be able to avail the tax credit. The same would be available in PRADAN Portal for the bidder's information. Bidder has to rectify the data discrepancy in the GSTN portal or issue credit note or debit note (details also to be uploaded in GSTN portal) for the shortages or rejections in the supplies or additional claims for processing of such invoices.</p> <p>4. In cases where invoice details have been uploaded by the bidder but failed to remit the GST amount to GST Department within stipulated time, then GST on the invoices in default will be recovered from the bidder along with the applicable interest.</p> <p>5. In case GST credit is delayed/denied to BHEL due to non/delayed receipt of goods and/or tax invoice or expiry of timeline prescribed in GST law for availing such ITC, or any other reasons not attributable to BHEL, such GST amount will be recoverable from bidder along with interest levied/ leviable on BHEL.</p> <p>6. GST TDS deducted as per GST Act, is uploaded in GSTN portal along GSTR7. Bidders can directly download the GST TDS Certificate from the GSTN Portal.</p> <p>7. Bidders to note that Rules & Regulations pertaining to E-way bill system are to be strictly adhered to, as and when notified by Govt. authorities.</p> <p>8. Vendors who fall under the E-Invoice regulations, i.e., having an annual turnover of Rs. 10 crores (Rs 5 crore w.e.f 01.08.2023) in the previous year shall issue e-invoice in line with Rule 48(4) of CGST Rules failing which GST amount will not be reimbursed to the vendor even if the other requirements are fulfilled.</p> <p>9. In case the vendor is exempted by the GST department under the Rule 48(4) of CGST Rules from issuing E-invoice, a declaration as prescribed in the Notification 17/2022 - Central Tax dated 01-08-2022 shall be provided on the invoice.</p> <p>10. Vendors who do not fall under the E-Invoice regulations, i.e., whose annual turnover is less than Rs. 10 crores (Rs 5 crore w.e.f 01.08.2023) in the previous year have to give an undertaking indemnifying BHEL that the vendor is not falling under the E-invoice requirement category and that in case of any breach of this E-invoicing requirement, the vendor indemnifies BHEL of any consequences that may arise due to such a breach.</p> <p>11. No GST shall be levied on liquidated damages / penalty.</p>	

B.	Foreign Purchase (Imports) The offered price shall be inclusive of all the Taxes and duties as applicable in country of export / country of dispatch for the quoted price. Taxes deducted at source: a. In case of goods or services subject to Income tax in India, such tax as per the extant statute shall be recovered. b. In case bidder does not provide necessary documents for beneficial taxation (Refer clause 7-B-(ix) a-c of ITB), the TDS deduction shall be at the maximum percentage stipulated as per the provisions of Income Tax Act.		Non Deviatable
12 Payment Terms: Unless otherwise specified in SCC, following shall be the terms of Payment.			
A	Indigenous: a. Micro & Small Enterprises (MSEs) - 100% Direct EFT payment within 45 days b. Medium Enterprises - 100% Direct EFT payment within 60 days c. Non MSME Bidders - 100% direct EFT Payment within 90 Days Note A. Above due date is reckoned from the date of Receipt of material or 15 days from the date of submission of complete set of documents as per PO whichever is later. Objections, if any on the invoice, available on SUVIDHA portal need to be closed. In such instances, due date is reckoned from the closure of objections. Vendors are advised to get familiarized with the document exchange feature on SUVIDHA portal. Payment will be made for Material accepted value. B. MSEs (covered under MSME Act) need to register and renew periodically and update the same with BHEL C. The taxes that are reimbursed are limited to applicable taxes as on the Purchase Order delivery date or the amount actually paid whichever is less. D. Adherence to the above time schedule of payment is contingent upon Bidder complying with GST provisions and availment of Input Tax Credit by BHEL before the date of payment. E. In case of packaged items, 10% of supply value will be retained till completion of total supplies. F. Bidders to comply with clause 11 on GST requirements G. MSE benefits are not applicable to Traders / Wholesalers registered as MSEs. G. MSME vendors may avail the facility of invoice discounting through Trade Receivables Discounting System(TREDs) platforms like RXIL, INVOICEMART, M1XCHANGE and any other platforms onboarded from time to time.		
B	Imports: i) 100% payment (less Indian Agency Commission, if any) shall be through Wire Transfer with a credit period of 45 days - Cash Against Documents (CAD) ii) In case Bidder opts for Letter of Credit payment, the LC Usance period shall be 90 days with respective bank charges to respective accounts and loading of 0.50% iii) Indian Agency commission if payable and so specified in the Purchase order shall be paid in Indian Rupees, considering the SBI TT selling exchange rate, as on the date of payment after successful completion of the contract.		
C	Conditions for LC: a. LC validity period will be 90 days and for any extension, applicable charges will be to bidder's account. b. LC will be opened after successful completion of pre dispatch inspection prior to the scheduled / agreed delivery date. LC will be opened within 15 bank working days from the date of request.		Non Deviatable
D	Conditions for both Indigenous & Foreign Bidders: a. In case Bidders insist for lesser Credit period and BHEL accepts, a loading of 0.60% for every 15 days reduction will be applicable. b. In case PBG as required is not furnished, Payment will be released deducting the BG amount, which will be paid after expiry of warranty period against submission of supplementary claim. c. Payment does not imply in any respect whatsoever a waiver of Buyer's right to performance of the Order. Buyer is entitled to set off claimable debts against claimable liabilities with the bidder by means of a setoff Note.		Non Deviatable
E	Wherever EMD is applicable, the EMD will be paid back to unsuccessful bidders within fifteen days after award of the contract. Successful bidder's EMD will be retained till submission of Performance Bank Guarantee (PBG). Tender Fee wherever applicable is not refundable. No interest shall be payable by BHEL on earnest money or security deposit or any money due to the contractor by BHEL.		Non Deviatable

13	Penalty clause:		
	<p>In the event of delay in supply /part-supply of goods, Penalty as detailed below is leviable</p> <p>a. Penalty of 0.5% per week or part there of shall be levied, limited to a max of 10% (ten percent) of delayed portion value / order value (as specified in SCC).</p> <p>b. Penalty applicable for delay in documentation is as per SCC.</p> <p>c. Date Reckoned for Penalty</p> <ul style="list-style-type: none"> - Indigenous Orders with delivery terms FOR HPEP: C Note date. - Indigenous Orders (Others): Date of e-waybill. - Imports: For CIP/CIF Orders: IGM date - Imports: For FOB Orders: AWB / BL date - Imports: <ul style="list-style-type: none"> For FCA Orders: <ul style="list-style-type: none"> Date of acknowledgement from Freight Forwarder. For Ex Work Orders (both air and sea): <ul style="list-style-type: none"> Latest of Air Freight Request (AFR), Invoice, Packing List, Inspection date (if applicable) or any other documentary evidence confirming material readiness. <p>d. In case of Deviation to above Penalty clause, loading applicable to the extent to which not agreed by Bidder.</p> <p>e. Timelines as mentioned in the Annexure 1 will be considered for reckoning delivery.</p>		
14	Excess materials supplied beyond tolerance limit as specified in PO will not be paid and bidder may raise credit note for the excess/unaccepted material as per GST law.		Non Deviatable
15	Rejected materials , if any, shall be collected by the bidder within 90 days of such communication to the bidder. Beyond this period the bidder forfeits their right to the materials.		Non Deviatable
16	Guarantee / Warranty Period: Wherever required, and so provided in the specifications/SCC/Purchase Order, the bidder shall guarantee that the goods supplied shall comply with the specifications laid down, for materials, workmanship and performance. <p>a. Guarantee period shall be 12 months from the date of commissioning or 18 months from the date of supply whichever is earlier.</p> <p>b. In case erection & commissioning is involved, guarantee period shall be 12 months from the date of commissioning.</p> <p>c. In case of equipment bought as a package which are intended to be incorporated in installations or systems, the guarantee period shall be 12 months from the date of commissioning of such equipment.</p> <p>The guarantee period shall be extended by the period during which the goods are not in compliance. If the delivery is found to be non-complaint, bidder shall replace, repair or re-execute the as requested by BHEL. If the bidder defaults on his obligations, buyer has the right to proceed to replace, repair or re-execute at the bidder's expense. A guarantee period as described above shall apply afresh to replaced, repaired or re-executed parts of a delivery.</p> <p>Loading for deviation: In case warranty specified in SCC is over and above the period mentioned in b & c above; loading will be 1% per annum for the deviation in warranty end period, on the contract value. Expected commissioning period is as indicated in SCC.</p>		Non Deviatable
17	PERFORMANCE BANK GUARANTEE (PBG) (Applicable in case mentioned in SCC) In case enquiry specifically spells out PBG requirement, PBG is to be submitted by Bidder in requisite format as per Annexure VII. Further detailing on PBG as specified in SCC. The PBG shall be for the performance of the goods and shall remain binding notwithstanding such variations, alterations or extensions of item as may be made, give, conceded or agreed to between the Bidder and BHEL under these Terms and conditions or otherwise.		Non Deviatable

NOTE: Deviations (Commercial as well as Technical) from the tender specifications and conditions are generally not acceptable. However, deviation if any, shall be brought out clearly with proper justification in the offer. The deviation, if considered by BHEL, shall be loaded for comparison, while evaluating the offer. If a bidder unconditionally withdraws any deviation before price bid opening, the same shall not be loaded. Loading criteria in respect of major commercial conditions where deviations if any are accepted shall be as per clause No.18. The Bidders may specifically note the following.

18	<p>Evaluation and Loading Criteria:</p> <p>i) Evaluation Currency for this tender shall be "INR". ii) Evaluation of prices shall be done item-wise unless otherwise specified in the SCC. iii) Evaluation shall be on the basis of delivered cost, i.e. "Total Cost to BHEL" w.r.t the finalized technical scope and commercial conditions (after considering incidence of applicable taxes and duties and loading). iv) In the course of evaluation, if more than one Bidder happens to occupy L1 status, effective L1 will be decided by soliciting discounts from the respective L1 Bidders. In case more than one Bidder happens to occupy the L1 status even after soliciting discounts, the L1 Bidder shall be decided by a toss/draw of lots, in the presence of the respective L1 Bidders or their representatives. Ranking will be done accordingly. BHEL decision in such situations shall be final and binding.</p> <p>INDIGENOUS</p> <p>a. Bidder shall ensure to indicate the applicable taxes against each line item, failing which the same will be considered as inclusive/NIL. b. Ex-works offers received (as against FOR Destination mentioned in enquiry) shall be loaded by 2% of Ex-works value. c. GST and any other charges quoted will be added to the base price. However, in case input credit is available for GST (SGST, CGST/IGST), the same shall be excluded for arriving at "Total Cost to BHEL"</p> <p>IMPORTS</p> <p>For evaluation of offers in foreign currency, exchange rate (TT selling rate of State Bank of India) as on the date of bid opening (Part-I, in case of two-part bids) shall be considered. If the relevant day happens to be a bank holiday, then the forex rate as on the previous bank (SBI) working day shall be taken. In case of foreign Bidders, the quoted CIP price shall be loaded by the following factors to arrive at "Total Cost to BHEL": - Import duty as applicable on the date of Part-I bid opening.</p> <p>- Loading will be as per the table below</p> <table border="1" data-bbox="226 1053 928 1665"> <thead> <tr> <th></th> <th>Ex Works</th> <th>FOB/F CA</th> <th>CIF/C FR</th> <th>CIP</th> </tr> </thead> <tbody> <tr> <td>Foreign Inland freight and insurance</td> <td>2%</td> <td></td> <td></td> <td></td> </tr> <tr> <td>Marine freight and marine insurance</td> <td>3%</td> <td>3%</td> <td></td> <td></td> </tr> <tr> <td>Destination Port handling charges</td> <td>0.50%</td> <td>0.50%</td> <td>0.50%</td> <td></td> </tr> <tr> <td>clearing charges & inland freight and insurance</td> <td>2%</td> <td>2%</td> <td>2%</td> <td>2%</td> </tr> </tbody> </table> <p>COMMON LOADING FOR IMPORTS & INDIGENOUS that will be added for arriving the "Total Cost to BHEL" A. Loading on Deviated Penalty clause shall be 10% or to the extent to which the bidder has opted for deviation. B. Loading for payment terms as per clause 12 of ITB C. Loading for deviation in Warranty & PBG as per clause 16,17.</p>		Ex Works	FOB/F CA	CIF/C FR	CIP	Foreign Inland freight and insurance	2%				Marine freight and marine insurance	3%	3%			Destination Port handling charges	0.50%	0.50%	0.50%		clearing charges & inland freight and insurance	2%	2%	2%	2%
	Ex Works	FOB/F CA	CIF/C FR	CIP																						
Foreign Inland freight and insurance	2%																									
Marine freight and marine insurance	3%	3%																								
Destination Port handling charges	0.50%	0.50%	0.50%																							
clearing charges & inland freight and insurance	2%	2%	2%	2%																						
19	<p>Procurement directly from the manufacturers/ suppliers shall be preferred. However, no agent shall be allowed to represent more than one manufacturer/ supplier in the same tender. Moreover, either the agent could bid on behalf of the manufacturer/ supplier or the manufacturer / supplier could bid directly but not both. In case bids are received from both from the manufacturer/ supplier and the agent, bid received from the agent shall be ignored.</p>																									
20	<p>RIGHT OF REJECTION /NON- PLACEMENT OF PO: BHEL reserves the right to accept or reject any or all bid/s in full or part without assigning any reason whatsoever.</p>																									
21	<p>INTEGRITY PACT Bidders shall have to enter into Integrity Pact with BHEL as per Annexure VI - for Tender value of rupees two crores and above and shall be signed by the authorized signatory along with the offer, failing which Bidder's offer will be rejected.</p>																									
22	<p>Public Procurement</p>																									
A	<p>Make in India For this Procurement, the local content to categorize a bidder as a Class I local bidder / Class II local bidder / Non-Local bidder and purchase preference to Class I local bidder, is as defined in Public Procurement (Preference to Make in India) order No P-45021/2/2017-PP(BE-II) dated 04-06-2020 issued by DPIIT as amended from time to time. Proforma for self-certification for minimum local content and auditor's certification is given in Annexure III.</p>																									

B	Any Bidder from a country which shares a land border with India will be eligible to bid in this tender only if the bidder is registered with competent authority. GOI website https://www.mea.gov.in/ to be referred for latest details of competent authority and exemptions . Proforma for self-certification for compliance is given in Annexure IV.												
C	Startups: For Start-ups duly registered with DPIIT (Copy of certificate to be provided), condition of prior turnover and prior experience in Public Procurement may be relaxed subject to meeting of Quality and Technical Specifications. Startups are exempt from paying EMD.												
23	Benefits earmarked for Purchase from Micro & Small Enterprises (MSEs) – Indigenous Purchase												
A	<p>All Micro and Small Enterprises (MSEs) as defined in MSE Procurement Policy are exempt from Paying EMD. NSIC/UDYAM registered bidders shall submit NSIC/UDYAM Certificate along with bid documents.</p> <p>Any Bidder falling under MSE category shall furnish the following details & submit documentary evidence/ Govt. Certificate etc. in support of the same along with their techno-commercial offer.</p> <table border="1" data-bbox="252 652 1018 905"> <thead> <tr> <th>Type under MSE</th> <th>SC/ST Owned</th> <th>Women Owned</th> <th>Others (excluding SC/ST & Women Owned)</th> </tr> </thead> <tbody> <tr> <td>Micro</td> <td></td> <td></td> <td></td> </tr> <tr> <td>Small</td> <td></td> <td></td> <td></td> </tr> </tbody> </table> <p>Note: If the bidder does not furnish the above in the tender, offer shall be processed construing that the bidder is not falling under MSE category.</p> <p>Date to be reckoned for determining the deemed validity will be the last date of Technical bid submission. Non- submission of such document will lead to consideration of their bid, at par with other bidders and MSE status of such bidders shall be shifted to Non- MSE Category till the bidder submits these documents.</p>	Type under MSE	SC/ST Owned	Women Owned	Others (excluding SC/ST & Women Owned)	Micro				Small			
Type under MSE	SC/ST Owned	Women Owned	Others (excluding SC/ST & Women Owned)										
Micro													
Small													
B	MSE suppliers can avail the intended benefits in respect of the procurements related to the Goods and Services only (Definition of Goods and Services as enumerated by Govt. of India vide Office Memorandum F. No. 21(8)/2011-MA dtd. 09/11/2016 office of AS & DC, MSME) and subsequent amendments & clarifications, if any. Documents NSIC/UDYAM Certificate submitted by the bidder shall be verified by BHEL for rendering the applicable benefits.												
C	If an enterprise falling under MSME category as defined in the Act, graduates to a higher category from its original category or beyond the purview of the Act, it shall continue to avail all non-tax benefits of its original category notified by the Ministry of Micro, Small and Medium Enterprise for a period of three years from the date of such graduation to the higher category.												
D	BHEL HPEP is registered with TReDS (RXIL , M1XCHANGE , InvoiceMart) platform. MSME bidders are requested to get registered with TReDS(RXIL / M1XCHANGE / InvoiceMart/ exchanges added from time to time) platform to avail the facility as per the GOI guidelines.												
24	Inspection Measuring and Test Equipment (IMTE) used by the Bidder/ Contractor or sub-contractor shall be calibrated, maintained and controlled. Calibration shall be valid and IMTE maintained in sound condition during usage.												
25	ISO-9001, ISO14001 & OHSMS 45001 shall be complied.												
26	If BHEL registered supplier is not quoting against this NIT, supplier shall send regret letter positively with valid reasons for not participating. Repeated lack of response on the part of supplier may lead to deletion of such registered supplier from BHEL's approved supplier's list as per BHEL SEARP Guidelines.												
27	<p><u>BREACH OF CONTRACT, REMEDIES AND TERMINATION</u></p> <p>27.1 BREACH OF CONTRACT: The following shall amount to breach of contract:</p> <ol style="list-style-type: none"> Non-supply of material/ non-completion of work by the Supplier/Vendor within scheduled delivery/ completion period as per contract or as extended from time to time. The Supplier/Vendor fails to perform as per the activity schedule and there are sufficient reasons even before expiry of the delivery/ completion period to justify that supplies shall be inordinately delayed beyond contractual delivery/ completion period. The Supplier/Vendor delivers equipment/ material not of the contracted quality. The Supplier/Vendor fails to replace the defective equipment/ material/ component as per guarantee clause. Withdrawal from or abandonment of the work by the Supplier/Vendor before completion as per contract. Assignment, transfer, subletting of Contract by the Supplier/Vendor without BHEL's written permission resulting in termination of Contract or part thereof by BHEL. Non-compliance to any contractual condition or any other default attributable to Supplier/Vendor. Any other reason(s) attributable to Vendor towards failure of performance of contract. In case of breach of contract, BHEL shall have the right to terminate the Purchase Order/ Contract either in whole or in part thereof without any compensation to the Supplier/Vendor. Any of the declarations furnished by the contractor at the time of bidding and/ or entering into the contract for supply are found untruthful and such declarations were of a nature that could have resulted in non-award of contract to the contractor or could expose BHEL and/ or Owner to adverse consequences, financial or otherwise. Supplier/Vendor is convicted of any offence involving corrupt business practices, antinational activities or any such offence that compromises the business ethics of BHEL, in violation of the Integrity Pact entered into with BHEL has the potential to harm the overall business of BHEL/ Owner. <p>Note- Once BHEL considers that a breach of contract has occurred on the part of Supplier/Vendor, BHEL shall notify the Supplier/Vendor by way of notice in this regard. Contractor shall be given an opportunity to rectify the reasons causing the breach of contract within a period of 14 days.</p> <p>In case the contractor fails to remedy the breach, as mentioned in the notice, to the satisfaction of BHEL, BHEL shall have the right to take recourse to any of the remedial actions available to it under the relevant provisions of contract</p>												

	<p>27.2 Remedies in case of Breach of Contract.:</p> <p>i. Wherein the period as stipulated in the notice issued under clause 27.1 has expired and Supplier/Vendor has failed to remedy the breach, BHEL will have the right to terminate the contract on the ground of "Breach of Contract" without any further notice to contractor.</p> <p>ii. Upon termination of contract, BHEL shall be entitled to recover an amount equivalent to 10% of the Contract Value for the damages on account of breach of contract committed by the Supplier/Vendor. This amount shall be recovered by way of encashing the security instruments like performance bank guarantee etc available with BHEL against the said contract. In case the value of the security instruments available is less than 10% of the contract value, the balance amount shall be recovered from other financial remedies (i.e. available bills of the Supplier/Vendor, retention amount, from the money due to the Supplier/Vendor etc. with BHEL) or the other legal remedies shall be pursued.</p> <p>iii. Wherever the value of security instruments like performance bank guarantee available with BHEL against the said contract is 10% of the contract value or more, such security instruments to the extent of 10% contract value will be encashed. In case no security instruments are available or the value of the security instruments available is less than 10% of the contract value, the 10% of the contract value or the balance amount, as the case may be, will be recovered in all or any of the following manners:</p> <p>iv. In case the amount recovered under sub clause (a) above is not sufficient to fulfil the amount recoverable then; a demand notice to deposit the balance amount within 30 days shall be issued to Supplier/Vendor.</p> <p>v. If Supplier/Vendor fails to deposit the balance amount within the period as prescribed in demand notice, following action shall be taken for recovery of the balance amount:</p> <p>a). from dues available in the form of Bills payable to defaulted Supplier/Vendor against the same contract.</p> <p>b). If it is not possible to recover the dues available from the same contract or dues are insufficient to meet the recoverable amount, balance amount shall be recovered from any money(s) payable to Supplier/Vendor under any contract with other Units of BHEL including recovery from security deposits or any other deposit available in the form of security instruments of any kind against Security deposit or EMD.</p> <p>vi. In-case recoveries are not possible with any of the above available options, Legal action shall be initiated for recovery against defaulted supplier/Vendor.</p> <p>vii. It is an agreed term of contract that this amount shall be a genuine pre-estimate of damages that BHEL would incur in completion of balance contractual obligation of the contract through any other agency and BHEL will not be required to furnish any other evidence to the Supplier/Vendor for the purpose of estimation of damages.</p> <p>viii. In addition to the above, imposition of liquidated damages, debarment, termination, de-scoping, short-closure, etc., shall be applied as per provisions of the contract.</p> <p>ix. Non-performance of contract attracts penal provisions in line with BHEL guidelines for Suspension of Business Dealings (SBD).</p> <p>Note: 1) The defaulting Supplier/Vendor shall not be eligible for participation in any of the future enquiries floated by BHEL to complete the balance work. The defaulting contractor shall mean and include:</p> <p>(a) In case defaulted Supplier/Vendor is the Sole Proprietorship Firm, any Sole Proprietorship Firm owned by same Sole Proprietor.</p> <p>(b) In case defaulted Supplier/Vendor is The Partnership Firm, any firm comprising of same partners/ some of the same partners; or sole proprietorship firm owned by any partner(s) as a sole proprietor.</p>
28	Any other terms and conditions of the bidder attached / referred against the tender enquiry will not be considered.
29	All drawings, patterns and tools supplied by BHEL or made at BHEL's expense are BHEL's property. These cannot be used or referred to any other party and must be used only in the execution of BHEL's orders.
30	Any amount payable by the bidder under any of the conditions of this contract shall be liable to be adjusted against any amount payable to the bidder under any other work / contract awarded by BHEL HPEP or any other BHEL Units. This is without prejudice to any other action as may be deemed fit by BHEL.
31	The bids of the bidders who are on the banned list and also the bids of the bidders, who engage the services of the banned firms, will be rejected. The list of firms banned by BHEL is available on BHEL web site: www.bhel.com
32	Ordering and confirmation of order
	<p>The bidder shall send the order acceptance within one week from the date of LOI/Purchase order or such other period as specified/agreed by the Buyer. Buyer reserves the right to revoke the order placed if the order confirmation differs from the original order placed. Buyer shall be legally bound, only if agreed for any deviation explicitly in writing. The acceptance of deliverables or supplies by Buyer as well as payments made in this regard shall not imply acceptance of any deviations. The Purchase order will be deemed to have been accepted if no communication to the contrary is received within one week (or the time limit as specified /agreed by the Buyer) from the date of P.O.</p> <p>Buyer, is at liberty to send signed P.O. through electronic media such as e-mail and the receipt of which shall be treated as receipt of order.</p>
33	Execution
	The whole contract is to be executed in the most workman like manner, substantial and approved as per the contracted terms.
34	Progress Report
	<p>The bidder shall render such report as to the progress of work and in such form as may be called for by the Buyer from time to time. The submission and acceptance of such reports shall not prejudice the rights of the buyer in any manner. Bidder shall communicate to BHEL immediately, the change of address, ownership, contact person(s), the mobile numbers and e-mail of the dealing person concerned.</p> <p>Milestones shall be periodically updated by bidder through PRADAN Portal (https://hpep.bhel.com/mm/). Non updation will adversely affect service rating of bidder performance.</p>

35	Non-disclosure Obligations
	<p>Drawings, technical documents or other technical information received by one party shall not without the consent of the other party, be used for any other purpose than that for which they were provided. They may not, without the consent of the submitting party, otherwise be used or copied, reproduced, transmitted or communicated to third parties. All information and data contained in general product documentation, whether in electronic or any other form, are confidential and binding only to the extent that they are by reference expressly included in the contract.</p> <p>The bidder shall, as per agreed date/s but not later than the date of delivery, provide free of charge any information and/or drawings which are necessary to permit the Buyer to erect, commission, operate and maintain the product. Such information and drawings shall be supplied as specified in technical specification.</p> <p>All intellectual properties, including designs, drawings and product information etc. exchanged during the formation and execution of the contract shall continue to be the property of the submitting party.</p> <p>The bidder shall provide Buyer with all information pertaining to the delivery in so far as it could be of importance to Buyer. The bidder shall not reveal confidential information to its own employees not involved with the tender/contract and its execution and delivery or to third parties, unless Buyer has agreed to this in writing beforehand. The bidder shall not be entitled to use the Buyer's name in advertisements and other commercial publications including website without prior written permission from Buyer.</p> <p>In the event of violation of the confidentiality as agreed, BHEL will take legal action as deemed fit. Non-disclosure agreement to be entered as per Annexure- II wherever applicable.</p>
36	Inspection and Testing
A	<p>The goods and stores shall be manufactured by approved quality system and each part/component may be inspected and tested by the Buyer prior to shipment and shall comply with relevant requirements. Buyer has the right to inspect at any stage during manufacture/ delivery.</p>
B	<p>Buyer or his authorized representative shall be entitled at all reasonable times during execution to inspect, examine and test at the bidder's premises the material and workmanship of all stores to be supplied under the contract, and if the part of the stores are being manufactured at other premises, the bidder shall obtain for buyer or his authorized representative permission to inspect, examine and test as if the said stores are being manufactured at the bidder's premises. Such inspection, examination and testing, if made shall not release the bidder from any obligation under the contract.</p> <p>For indigenous bidders all costs related to first inspection request shall be borne by the buyer and the cost of subsequent inspections due to non-readiness of material/rework/ rejections shall be borne by the bidder. In case of imports all inspection charges including third party inspections if any shall be borne by the bidder. The cost of inspection staff/third party specified by the Buyer shall be borne by bidder unless otherwise specifically agreed. If the contract provides for tests on the premises of the bidder or any of his sub-contractor/s, bidder shall be responsible to provide such assistance, labor, materials, electricity, fuels, stores, apparatus, instruments as may be required and as may be reasonably demanded to carry out such tests efficiently.</p> <p>Cost of any type test or such other special tests shall be borne by the bidder unless otherwise specifically agreed in the contract.</p> <p>The Bidder shall give the authorized representative of the buyer reasonable notice in writing of the date on and the place at which any stores will be ready for inspection/ testing as provided in the Contract. Annexure – I, may strictly be complied with or the time lines. Any delay in submission of the documents by the bidder will not alter the delivery date.</p>
37	Quality and Condition of the Deliverables
	<p>The bidder shall be responsible for compliance with applicable technical, safety, quality, environmental requirements and other regulations in relation to products, packaging and raw and ancillary materials.</p>
38	Packaging and Dispatch
	<p>The bidder shall package the deliverables safely and carefully and pack them suitably in all respects considering the peculiarity of the material for normal safe transport by sea/air/rail/road to its destination suitably protected against loss, damage, corrosion in transit and the effect or tropical salt laden atmosphere. The packages shall be provided with fixtures/hooks and sling marks as may be required for easy and safe handling by mechanical means. Special packaging conditions/ environmental conditions as defined in the NIT shall be fully complied.</p> <p>Each package must be marked with consignee name, address, P.O. number, Package Number, gross weight & net weight, dimensions (Lx B x H) and bidder's name. The packing shall allow for easy removal and checking of goods on receipt and comply with carrier's conditions of packing or established trade practices. Packing list for goods inside each package with P.O. item No. & quantity must also be fixed securely outside the box to indicate the contents. If any consignment needs special handling instruction, the same shall be clearly marked with standard symbols/instructions. Hazardous material should be notified as such and their packing, transportation and other protection must conform to relevant regulations.</p>
39	Contract variations; Increase or decrease in the scope of supply
	<p>Buyer may vary the contracted scope during execution due to exigencies of project requirement.</p> <p>If the bidder is of the opinion that the variation has an effect on the agreed price or delivery period, Buyer shall be informed of this immediately in writing along with technical details, and in the event of additional work, submit a quotation with regards to the price and period involved, as well as the effect this additional work will have on the other work to be performed by the bidder. Wherever unit rates are available in the contract, the same shall be applied to such additional work. The bidder shall not perform additional work before buyer has issued written instructions/amendment to the purchase order to that effect.</p> <p>The work which the bidder should have or could have anticipated in terms of delivering the service (s) and functionality (ies) as described in this agreement should be executed by the bidder without any price implication.</p> <p>In case of no change in the scope / technical specifications, bidder shall endeavor to keep the material ready and intimate the same to BHEL within the contractual delivery date, failing which, the delay if any will be attributed to supplier, and any upward price variation thereof for delivery at a later date is not admissible.</p>
40	Rejected/Short shipments/ warranty/guarantee replacements
	<p>In case of any short shipment during initial supply which is subsequently dispatched by the bidder or any guarantee / warranty replacements shall be dispatched on "DDP-Delivered duty paid BHEL stores" basis for imported items and "FOR-BHEL Stores/designated destination" basis for indigenous items.</p>

41	Export Administration Regulations
	If a delivery includes such technology and / or supply that is subjected to the export regulations the bidder shall obtain due permissions, approvals, license etc.
42	Force Majeure
	<p>The bidder shall not be considered in default if delay occurs due to causes beyond their control such as Acts of God, Natural calamities, Fire, Frost, Flood, Civil War, civil commotion, riot, Government Restrictions.</p> <p>Only those causes that have duration of more than seven days shall be considered cause of force majeure. Notification to this effect duly certified by local chamber of commerce/statutory authorities with supporting documents shall be given by the bidder to BHEL by registered letter/courier service immediately without loss of time.</p> <p>In the event of delay due to such causes the delivery schedule shall be extended for a length of time equal to the period of Force Majeure or at the option of BHEL the order may be cancelled. Such cancellation would be without any liability whatsoever on the part of BHEL.</p> <p>In the event of such cancellation the bidder shall refund any amount advanced or paid to the bidder by BHEL and deliver back any material issued to him by BHEL and release facilities, if any provided by BHEL.</p>
43	Non-waiver of Defaults
	If any individual provision of the contract is invalid, the other provisions shall not be affected.
44	Settlement of Disputes
	<p>Except as otherwise specifically provided in the contract, all disputes concerning questions of the facts arising under the contract, shall be decided by the Buyer, subject to written appeal by the bidder to the buyer, whose decision shall be final. Any disputes of differences shall to the extent possible be settled amicably between the parties thereto, failing which the disputed issues shall be settled through arbitration</p> <p>The bidder shall continue to perform the contract, pending settlement of disputes(s).</p>
45	Conciliation clause
	<p>CONCILIATION CLAUSE FOR CONDUCTING CONCILIATION PROCEEDINGS UNDER THE BHEL CONCILIATION SCHEME, 2018: The Parties agree that if at any time (whether before, during or after the arbitral or judicial proceedings), any Disputes (which term shall mean and include any dispute, difference, question or disagreement arising in connection with construction, meaning, operation, effect, interpretation or breach of the agreement, contract or the Memorandum of Understanding, penalty deduction, time extension), which the Parties are unable to settle mutually, arise inter-se the Parties, the same may, be referred by either party to Conciliation to be conducted through Independent Experts Committee to be appointed by competent authority of BHEL from the BHEL Panel of Conciliators.</p> <p>The proceedings of Conciliation shall broadly be governed by Part-III of the Arbitration and Conciliation Act 1996 or any statutory modification thereof and as provided in Procedure in http://www.bhel.com/index.php/story_details?story=2454 .</p> <p>The Procedure together with its Formats will be treated as if the same is part and parcel hereof and shall be as effectual as if set out herein in this ITB</p>
46	ARBITRATION
	<p>46.1 Except as provided elsewhere in this Contract, in case Parties are unable to reach amicable settlement (whether by Conciliation to be conducted as provided in Clause 45 herein above or otherwise) in respect of any dispute or difference; arising out of the formation, breach, termination, validity or execution of the Contract; or, the respective rights and liabilities of the Parties; or, in relation to interpretation of any provision of the Contract; or, in any manner touching upon the Contract (hereinafter referred to as the 'Dispute'), then, either Party may, refer the disputes to IAMC (International Arbitration and Mediation Centre, Hyderabad) and such dispute to be adjudicated by Sole Arbitrator appointed in accordance with the IAMC Rules.</p> <p>46.2 A party willing to commence arbitration proceeding shall invoke Arbitration Clause by giving notice to the other party in terms of section 21 of the Arbitration & Conciliation Act, 1996 (hereinafter referred to as the 'Notice') before referring the matter to IAMC. The Notice shall be addressed to the Head of the Unit, BHEL, executing the Contract and shall contain the particulars of all claims to be referred to arbitration with sufficient detail and shall also indicate the monetary amount of such claim including interest, if any.</p> <p>46.3 After expiry of 30 days from the date of receipt of aforesaid notice, the party invoking the Arbitration shall submit that dispute to IAMC and that dispute shall be adjudicated in accordance with their respective Arbitration Rules. The matter shall be adjudicated by a Sole Arbitrator who shall necessarily be a Retd Judge having considerable experience in commercial matters to be appointed/nominated by the respective institution. The cost/expenses pertaining to the said Arbitration shall also be governed in accordance with the Rules of the respective Arbitral Institution. The decision of the party invoking the Arbitration for reference of dispute to a specific Arbitral institution for adjudication of that dispute shall be final and binding on both the parties and shall not be subject to any change thereafter. The institution once selected at the time of invocation of dispute shall remain unchanged.</p> <p>46.4 The fee and expenses shall be borne by the parties as per the Arbitral Institutional rules.</p> <p>46.5 The Arbitration proceedings shall be in English language and the seat and venue of Arbitration shall be Hyderabad.</p> <p>46.6 Subject to the above, the provisions of Arbitration & Conciliation Act 1996 and any amendment thereof shall be applicable. All matters relating to this Contract and arising out of invocation of Arbitration clause are subject to the exclusive jurisdiction of the Court(s) situated at Hyderabad.</p> <p>46.7 Notwithstanding any reference to the Designated Engineer or Conciliation or Arbitration herein, a. the parties shall continue to perform their respective obligations under the Contract unless they otherwise agree. Settlement of Dispute clause cannot be invoked by the Contractor, if the Contract has been mutually closed or 'No Demand Certificate' has been furnished by the Contractor or any Settlement Agreement has been signed between the Employer and the Contractor.</p> <p>46.8 It is agreed that Mechanism of resolution of disputes through arbitration shall be available only in the cases where the</p>

	value of the dispute is less than Rs. 10 Crores. 46.9 In case the disputed amount Claim, Counter claim including interest is Rs. 10 crores and above, the parties shall be within their rights to take recourse to remedies other than Arbitration, as may be available to them under the applicable laws after prior intimation to the other party. Subject to the aforesaid conditions, provisions of the Arbitration and Conciliation Act, 1996 and any statutory modifications or re-enactment thereof as amended from time to time, shall apply to the arbitration proceedings under this clause. 46.10 In case, multiple arbitrations are invoked (whether sub-judice or arbitral award passed) by any party to under this contract, then the cumulative value of claims (including interest claimed or awarded) in all such arbitrations shall be taken in account while arriving at the total claim in dispute for the subject contract for the purpose of clause 46.9. Disputes having cumulative value of less than 10 crores shall be resolved through arbitration and any additional dispute shall be adjudicated by the court of competent jurisdiction. In the event of any dispute or difference relating to the interpretation and application of the provisions of commercial contract(s) between Central Public Sector Enterprises (CPSEs)/ Port Trusts inter se and also between CPSEs and Government Departments/Organizations (excluding disputes concerning Railways, Income Tax, Customs & Excise Departments), such dispute or difference shall be taken up by either party for resolution through AMRCD (Administrative Mechanism for Resolution of CPSEs Disputes) as mentioned in DPE OM No. 05/0003/2019-FTS-10937 dated 14-12-2022 as amended from time to time.	
47	Applicable Laws and jurisdiction of Courts	
	This contract shall be governed by the Law for the time being in force in the Republic of India. Subject to clause 46 of this contract, the Civil Court having original Civil Jurisdiction at Hyderabad, shall alone have exclusive jurisdiction in regard to all matters in respect of the Contract."	
48	BHEL-Fraud prevention policy shall be adhered to.	
	The Bidder along with its associate/ Collaborators/ Sub-contractors/ sub-bidders/ consultants/ service providers shall strictly adhere to BHEL Fraud Prevention policy displayed on BHEL Website http://www.bhel.com and shall immediately bring to the notice of BHEL management about any fraud or suspected fraud as soon as it comes to their notice. List of nodal officers is hosted on BHEL Hyderabad website https://hpep.bhel.com/ .	
49	Suspected Cartel Formation	
	The Bidder declares that they will not enter into any illegal or undisclosed agreement or understanding, whether formal or informal with other Bidder(s). This applies in particular to prices, specifications, certifications, subsidiary contracts, submission or non-submission of bids or any other actions to restrict competitiveness or to introduce cartelization in the bidding process. In case , the Bidder is found having indulged in above activities, suitable action shall be taken by BHEL as per extant policies / guidelines .	
50	Treatment of cases regarding conflict of interest:	
	The bidder notes that a conflict of interest would said to have occurred in the tender process and execution of the resultant contract, in case of any of the following situations: i) If its personnel have a close personal, financial, or business relationship with any personnel of BHEL who are directly or indirectly related to the procurement or execution process of the contract, which can affect the decision of BHEL directly or indirectly; ii) The bidder (or his allied firm) provided services for the need assessment/procurement planning of the Tender process in which it is participating; iii) Procurement of goods directly from the manufacturers/ suppliers shall be preferred. However, if the OEM/ Principal insists on engaging the services of an agent, such agent shall not be allowed to represent more than one manufacturer/ supplier in the same tender. Moreover, either the agent could bid on behalf of the manufacturer/ supplier or the manufacturer/ supplier could bid directly but not both. In case bids are received from both the manufacturer/supplier and the agent, bid received from the agent shall be ignored. However, this shall not debar more than one Authorized distributor (with/ or without the OEM) from quoting equipment manufactured by an Original Equipment Manufacturer (OEM) in procurements under a Proprietary Article Certificate. iv) A bidder participates in more than one bid in this tender process. Participation in any capacity by a Bidder (including the participation of a Bidder as a partner/ JV member or sub-contractor in another bid or vice-versa) in more than one bid shall result in the disqualification of all bids in which he is a party. However, this does not limit the participation of an entity as a subcontractor in more than one bid if he is not bidding independently in his own name or as a member of a JV. The Bidder declares that they have read and understood the above aspects, and the bidder confirms that such conflict of interest does not exist and undertakes that they will not enter into any illegal or undisclosed agreement or understanding, whether formal or informal with other Bidder(s), in this regard. This applies in particular to prices, specifications, certifications, subsidiary contracts, submission or non-submission of bids or any other actions to restrict competitiveness or to introduce cartelization in the bidding process. In case, the Bidder is found having indulged in above activities, the same will be considered as a violation of the tender conditions, and suitable action shall be taken by BHEL as per extant policies/guidelines.	
51	Escalation Matrix	
	Details	Name
	Authorised representative	
	Technical In-charge	
	Finance and Taxation	
	Escalation for above	
	Contact Number	



52	Grievance Redressal Mechanism
	<p>To promote transparency and ensure fair treatment of all bidders, a structured Grievance Redressal Mechanism is in place to address any concerns or issues arising during the tendering process or in subsequent business dealings with the company. Suppliers/Contractors are requested to follow the below escalation process for grievance resolution:</p> <ol style="list-style-type: none">1. First Level: Any grievance should initially be addressed to the designated Dealing Officer, whose contact details are provided in the Notice Inviting Tender (NIT)/Contract.2. Second Level: If the issue remains unresolved, it may be escalated by lodging a formal grievance through the SUVIDHA Portal: https://suvidha.bhel.in/suvidha/. Responses will be provided in accordance with the defined escalation matrix.”

Note: Purchase officer has to fill Annexure-I while sending enquiry

Annexure-I
Timelines of activities

Enquiry/GeM Bid No

Sl. No.	Activities	Agency	Alloted Time
1	Purchase Order acknowledgement	Seller	5 days from PO
2	Correction in PO (if any)	BHEL	3 days from intimation by seller
3	Document submission(Dwg+Datasheet+QAP) if any for approval (Rev.00)	Seller	10 days from PO
4	Approval/Comment on submitted documents (Rev.00)	BHEL	7 days from Submission
5	Resubmission of documents if any for approval (Rev.01)	Seller	3 days from comments
6	Approval on submitted documents (Rev.01)	BHEL	5 days from comments
7	BHEL TPIA allocation time	BHEL	5 days from Ins.call date
8	Dispatch clearance	BHEL	3 days after receipt of BHEL TPI/Customer Cleared Test certificate (from seller)

*Delivery time shall be as per Enquiry/Bid.

#Delay if any from BHEL alltoted time shall be extended only.

Sellers Signature with stamp

(To be executed on Non- Judicial Stamp Paper for an appropriate value.

To be stamped as an agreement)

(For Suppliers on Unit's / Division's PMD)

ANNEXURE-II

Framework Confidentiality Agreement Cum Undertaking

This Agreement made on this the _____ day of (month) _____ 20 ____ ("Effective Date") by and between M/s. BHARAT HEAVY ELECTRICALS LIMITED, having registered office at "BHEL House", Siri Fort, New Delhi – 110049 (India), acting through its _____ Unit (hereinafter may be referred to as "BHEL" or "the company").

And

M/s. _____ (address) _____
represented by authorized representative Sri _____ (herein after referred to as the "Supplier").

The supplier and the company may, unless the context otherwise requires, hereinafter be collectively referred to as "Parties" or singly as the "Party".

RECITALS

Whereas, BHEL is engaged in the design, engineering, manufacturing, construction, testing, commissioning and servicing of a wide range of products, systems and services for the core sectors of the economy, viz. Power, Transmission, Industry, Transportation, Renewable energy, Oil & Gas and Defence and providing associated services to varied customers in relation to which BHEL / its affiliates own valuable information of a secret and confidential nature.

Whereas the Company may, in connection with contract(s) (as defined hereunder) placed or to be placed upon the supplier, or otherwise, from time to time, make available, Technical Information as is defined hereunder.

And Whereas BHEL is willing to provide such Technical Information to the Supplier from time to time and the Supplier understands and acknowledges that such Technical Information is valuable for the Company and as such is willing to protect confidentiality of such information, subject to the terms and conditions set out hereunder.

Now therefore, in view of the foregoing premises and in consideration of the mutual covenants and agreements hereinafter set forth, the parties agree as under:

1. Definitions:

Unless the context so requires, in this Agreement, the following terms will bear the meaning ascribed to the said term in this clause.

- A. **“Contract”** means the contract entered into with a supplier and includes a Purchase Order, or a Work Order for procurement of any goods or for provision of any services.
 - B. **“Effective Date”** means the date of this Agreement as mentioned in the preamble of this Agreement.
 - C. **“Supplier”** includes a Contractor or a Vendor of the Company whether for supplying of goods or for providing any services under a Contract or both.
 - D. **“Technical Information”** includes Drawings, and / or Product Standards and / or Specifications and / or Corporate / Plant Specifications and / or Technological Process Sheets and / or Technical Data Sheets and / or Jigs & Fixtures and / or Pattern & Dies and / or Special Gauges and / or Tools etc. Belonging to or wherein the Company has acquired from a third party a right of user and includes any improvement thereto from time to time whether carried out by the Company or by the Suppliers.
 - E. **“Intended Purpose”** means the purpose for which the Technical Information is provided to the supplier under or in connection with a contract.
 - F. **“Improvement”** includes any modification made to, or adaptation of, the Technical Information which enhances or is calculated to enhance the performance (Whether in terms of effectiveness or in terms of efficiency or both) of the product and / or the service to be provided by the Supplier under a Contract.
2. This Agreement shall come into force / deemed to have come into force, as the case may be, on the Effective Date; or, on the first date when the Technical Information or any part thereof is provided by BHEL to the supplier; whichever is earlier.
3. **Agreement deemed to be incorporated in each contract:** Unless and to the extent otherwise stipulated in the Contract, the conditions of this Agreement are deemed to be incorporated in all Contracts which may be entered into between the Company and the Supplier. Further, unless otherwise stipulated, the obligations under this Agreement are and will be independent of the obligations under the Contracts and such obligations of the Supplier hereunder will remain of full effect and validity notwithstanding that the period of validity of the Contract has expired by efflux of time stipulated therein; or, the contract has been discharged by performance or breach; or, the termination of the Contracts for any reason whatsoever.
4. **Ownership:**
- 4.1 The Company may, from time to time, make available to the Supplier, Technical Information on a non-exclusive basis by way of loan.
- 4.2 The Supplier acknowledges and agrees that all Technical Information and copies thereof that are or may be provided by the Company to the Supplier, are and shall remain the property of

BHEL or that of the concerned entity from whom BHEL has obtained the Technical Information and such Technical Information are and shall constitute trade secrets of the BHEL. Nothing in this Agreement or in any disclosures made hereunder by or on behalf of the Company shall be construed as granting upon the Supplier any patent, copyright or design or any other intellectual property rights of whatsoever description that subsists or may hereinafter exist in the Technical Information. Furthermore, nothing in this Agreement or in any disclosures made hereunder by or on behalf of the Company shall be construed as granting upon the supplier any license or right of use of such patent, copyright or design or any other intellectual property rights of whatsoever description which may now or hereafter exist in the Technical Information except for use of the Technical Information strictly in accordance with this Agreement and the contract and / or as directed in writing by the Company, solely for the Intended Purpose under the Contract.

- 4.3 Neither party is obligated by or under this Agreement to purchase from or provide to the other party any service or product and that any such purchase / sale of any product and / or service by one party to the other party will be governed by the Contract if any, that may be entered into by and between the Company and the Supplier.
- 4.4 The Supplier is / has been made well aware and acknowledges that the Technical Information being / which may be shared with it by the Company has been either generated by the Company by incurring huge investment and cost or obtained from foreign collaborators under Technical Collaboration Agreement (TCA) with stringent confidentiality conditions.
- 4.5 The supplier agrees and undertakes to adhere to confidentiality requirements as applicable to BHEL under a TCA and also ensure that the confidentiality requirements are adhered to by all its concerned employees or sub-contractors /suppliers (where permitted to be engaged by BHEL). Any damages, losses, expenses of any description whatsoever, arising out of or in connection with a breach of the confidentiality requirements under a TCA owing to any act or omission on the part of the supplier or its employees or sub-contractors / suppliers that is claimed by a foreign collaborator from the Company shall be wholly borne by the Supplier and it shall keep BHEL fully indemnified in this behalf. The demand by the Company shall be conclusive upon the Supplier who shall thereupon forthwith pay to the Company without demur, dispute or delay the amount as demanded without demanding any further proof thereof.
- 4.6 The Supplier agrees and undertakes that unless so decided and advised by the Company in writing all rights / title to any Improvement to the Technical Information shall vest in the Company. The Supplier undertakes and agrees to inform forthwith to the Company of any such Improvement made to the Technical Information and transfer all drawings / documents or other materials connected with such Improvement to the Company and also agrees to fully cooperate with the Company for protecting the Company's interests in such Improvements

in the Technical Information including but not limited to obtaining necessary protection for the intellectual property rights in such improvement, if so desired by the Company. If a question arises whether a modification amounts to improvement to the Technical Information, the same shall be decided by the Company and such decision shall be final and binding upon the supplier.

5. Use and Non – Disclosure:

5.1 Unless otherwise stipulated by the Company, all Technical Information made available to the supplier, by the Company shall be treated as Confidential irrespective of whether the same is marked or otherwise denoted to be Confidential or not.

5.2 The Supplier undertakes and agrees that the Technical Information in its possession shall be held in strict confidence and will be used strictly in accordance with this Agreement and solely for the Intended Purpose under the Contract. Use of the Technical Information for any other purpose other than Intended Purpose is prohibited.

5.3 In particular, the Supplier shall not use Technical Information or any Improvement in its possession for the manufacture or procurement of the product(s) or components or parts thereof or use the Technical Information or any portion thereof or any modification or adaptation thereof in any form to provide any product and / or service to any third party, without the prior written consent of the Company.

5.4 The Supplier shall not disclose any of such Technical Information to any third party without the prior written consent of the Company. The Supplier agrees that without prior written consent of the Company, the supplier shall not disclose to a third party about the existence of this Agreement, or of the fact that it is / was in possession of or has experience in the use of any Technical Information nor shall the Supplier share in any manner whatsoever, with a third party, the name or details of any Contract(s) awarded by the Company to it or performed by the Supplier or the scope of work thereof or share any document or correspondence by and between the Company and the supplier in or in connection with this Agreement or such Contract(s). Notwithstanding what is stated elsewhere, the overall responsibility of any breach of the confidentiality provisions under this Agreement shall rest with the Supplier.

5.5 This Supplier undertakes and agrees not to make copies or extracts of and not to disclose to other any or all of the Technical Information in its possession, except as follows:

(a) The Supplier may disclose the Technical Information to such of its officers and employees strictly to the extent as is necessary for such officer or employee for the Intended Purpose, provided that the Confidential Information (or copies thereof) disclosed shall be marked

clearly as the confidential and proprietary information of Company and that such officers and employees shall similarly be bound by undertakings of confidence, restricted use and non-disclosure in respect of the Technical Information. The Supplier shall be responsible for any breach of such confidentiality provisions by such officers and employees.

- (b) With the prior written consent of Company, the supplier may disclose for the Intended Purpose such Technical Information as is provided for in such consent to such of its professional advisers: consultants, insurers and subcontractors who shall be similarly bound by undertakings of confidence, restricted use and non-disclosure in respect of such Technical Information.
- (c) The Supplier shall not be prevented to make any disclosure required by (i) order of a court of competent jurisdiction or (ii) any competent regulatory authority or agency where such disclosure is required by law, provided that where the supplier intends to make such disclosure, it shall first consult Company and take all reasonable steps requested by it to minimize the extent of the Technical Information disclosed and to make such disclosure in confidence and also shall cooperate with the Company in seeking any protective order or any other remedy from proper authority in this matter.

6. Exceptions:

The Obligations of the Supplier pursuant to the provisions of this agreement shall not apply to any Confidential Information that:

- a) was / is known to, or in the possession of the Supplier prior to disclosure thereof by the Company;
- b) is or becomes publicly known, otherwise than as a result of a breach of this agreement by the Supplier.
- c) is developed independently of the Disclosing party by the Supplier in circumstances that do not amount to a breach of the provisions of this Agreement or the Contract;
- d) is received from a third party in circumstances that do not result in a breach of the provisions of this Agreement.

- 7. The Obligation of maintaining confidentiality of the Technical Information on each occasion, shall subsist for the entire duration during which the Technical Information / equipment is in possession of the Supplier and shall thereafter subsist for a further period of _____ years from the date when the complete Technical Information has been returned in portions on different dates, the period of ____ years will be reckoned from the date when the last portion of the Technical Information has been returned. Notwithstanding the expiry of the confidentiality obligation, the obligation of the Supplier under clause 5.4 shall continue to subsist for a further period of _____ years.

8. Warranties & Undertakings:

- a) The Supplier undertakes to ensure the due observance of the undertakings of confidence, restricted use and non-disclosure by its persons to whom it discloses or releases copies or extracts of the Technical Information.
- b) The Supplier shall keep the Technical Information or improvement made therein properly segregated and not mix up the same with any other material / documents belonging to him / it or to any other third party.
- c) The Supplier further undertakes that he / it shall not hypothecate or give on lease or otherwise alienate or do away with any of the Technical Information and / or equipment of the Company, made available to him / it, and undertakes that he / it shall hold the same as a trustee, in capacity of custodian thereof and use / utilise the same solely for the purpose of executing the contract awarded by the Company.
- d) The Supplier further undertakes that he / it shall return all the equipment and / or Technical Information as far as practicable in the same condition in which the same was made available to him / it by the Company together with any Improvement thereon and the documents connected with such Improvement, to the Company forthwith upon completion of the scope of work or contract for which such Technical Information was provided by the Company to it or as directed by the Company together with a confirmation by way of an affidavit or in such manner as directed by the Company that it has not retained any equipment and / or Technical Information / improvement thereof. In case any such equipment and / or Technical Information or thereof shall remain in his possession or is not capable of being returned, the retention and use of such Technical Information or improvement thereto shall continue to be governed by this Agreement.
- e) The Supplier undertakes to indemnify the Company for all the direct, indirect and / or consequential losses, damages, expenses whatsoever including any consequential loss of business, profits suffered by the Company owing to breach by the Supplier of its obligations under this Agreement and / or the confidentiality requirements, if any, contained in the Contract and that the Supplier hereby agrees that the decision of the Company in all such or any such matter/s shall be final and binding on the Supplier. On mere written demand of the Company, the Supplier shall forthwith and without demur or delay pay to the Company any such sum as determined by the Company as the amount of loss or damage or expense which has been suffered by the Company. The Supplier agrees that the Company shall be entitled to withhold and appropriate any amount payable to the Supplier under any Contract then existing between the Company and the Supplier, in case the Supplier fails to make payment, in terms of the written demand, within 7 days thereof. Without prejudice to the forgoing actions, in respect to any breach of this Agreement, the Company shall be entitled to take

any other action against the Supplier as per applicable laws, the Contract, Company's applicable policies, guidelines rules, procedures, etc.

9. Without prejudice to any other mode of recovery as may be available to the Company for recovery of the amount determined as due as per Clause 9 (f) hereinabove, the Company shall have a right to withhold, recovery and appropriate the amount due towards such losses, damages, expenses, from any amount due to the Supplier in respect of any other Contract (s) placed on him / it by any department / office / unit/ division of the said Company.

10. Arbitration & Conciliation:

Except as provided elsewhere in this Contract, in case amicable settlement is not reached between the Parties, in respect of any dispute or difference; arising out of the formation, breach, termination, penalty deduction, validity or execution of the Contract; time extension, or, the respective rights and liabilities of the Parties; or, in relation to interpretation of any provision of the Contract; or, in any manner touching upon the Contract, then, either Party may, by a notice in writing to the other Party refer such dispute or difference to the sole arbitration . Sole arbitrator to be appointed by Head of the Unit - BHEL, HPEP.

The Arbitrator shall pass a reasoned award and the award of the Arbitrator shall be final and binding upon the Parties.

Subject as aforesaid, the provisions of Arbitration and Conciliation Act 1996 (India) or statutory modifications or re-enactments thereof and the rules made thereunder and for the time being in force shall apply to the arbitration proceedings under this clause.

The seat of arbitration shall be Sangareddy / Hyderabad, Telangana. The language of arbitration shall be English and the documents shall be submitted in English.

The cost of arbitration shall initially be borne equally by the Parties subject to the final apportionment of the cost of the arbitration in the award of the Arbitrator.

Subject to the arbitration in terms of clause 46 of ITB (clause 27 of ATC GeM), the courts at Sangareddy, Telangana State shall have exclusive jurisdiction over any matter arising out of or in connection with this contract.

Notwithstanding the existence or any dispute or differences and/or reference for the arbitration, the Contractor shall proceed with and continue without hindrance the performance of its obligations under this Contract with due diligence and expedition in a professional manner except where the Contract has been terminated by either Party in terms of this Contract.

ARBITRATION FOR CONTRACT WITH PUBLIC SECTOR ENTERPRISE (PSE) OR A GOVERNMENT DEPARTMENT

In the event of any dispute or difference relating to the interpretation and application of the provisions of commercial contract(s) between Central Public Sector Enterprises (CPSEs/ Port Trusts inter se and also between CPSEs and Government Departments/Organizations (excluding disputes concerning Railways, Income Tax, Customs & Excise Departments), such dispute or difference shall be taken up by either party for resolution through AMRCD as mentioned in DPE OM No 4(1)/2013-DPE(GM/FTS 1835 dated 22-05-2018

CONCILIATION CLAUSE FOR CONDUCTING CONCILIATION PROCEEDINGS UNDER THE BHEL CONCILIATION SCHEME, 2018: The Parties agree that if at any time (whether before, during or after the arbitral or judicial proceedings), any Disputes (which term shall mean and include any dispute, difference, question or disagreement arising in connection with construction, meaning, operation, effect, interpretation or breach of the agreement, contract or the Memorandum of Understanding, penalty deduction, time extension), which the Parties are unable to settle mutually, arise inter-se the Parties, the same may, be referred by either party to Conciliation to be conducted through Independent Experts Committee to be appointed by competent authority of BHEL from the BHEL Panel of Conciliators.

The proceedings of Conciliation shall broadly be governed by Part-III of the Arbitration and Conciliation Act 1996 or any statutory modification thereof and as provided in Procedure in http://www.bhel.com/index.php/story_details?story=2454 . The Procedure together with its Formats will be treated as if the same is part and parcel hereof and shall be as effectual as if set out herein in this ITB

11. Governing Law & Jurisdiction:

This agreement shall be construed and interpreted in accordance with the laws of India and shall have exclusive jurisdiction of Sangareddy/Hyderabad courts, Telangana, India.

SIGNATURE

WITNESSES

1

Name:

Address:

2

Name:

Address:

Annexure - III

Proforma for self-certification by Supplier for minimum local content on their letter head for tender value less than Rs 10 Crore

"We _____ (Name of Manufacturer) undertake that we meet the mandatory minimum Local Content (LC) requirement i.e. _____ (to be filled as notified in the policy) for claiming Purchase Preference linked with Local Contents under the Govt. policy against tender no. _____."

Auditor's certification with respect to minimum local content on the letter head of Statutory Auditor for tender value above Rs.10 crore

"We _____ the statutory auditor of M/s _____ (name of the bidder) hereby certify that M/s _____ (name of manufacturer) meet the mandatory Local Content requirements of the Goods and/or Services i.e. _____ (to be filled as notified in the policy) quoted vide offer No. _____ dated _____ against BHEL's tender No. _____ by M/s _____ (Name of the bidder)."

Annexure - IV

Proforma for self-certification by Supplier for Compliance to Clause No 20 (B)

I have read the clause regarding restrictions on procurement from a bidder of a country which shares a land border with India and I certify that M/s.... (Name of firm) is **not from such a country/is from such a country** (delete whichever is NOT applicable) and has been duly registered with the Competent authority (delete if NOT applicable) . I hereby certify M/s fulfills all requirements in this regard and is eligible to be considered . (where applicable , valid registration by the competent authority shall be attached)

Sd/-

Authorised Signatory with Stamp

Annexure V

(On Company Letter Head)

FORM NO. 10F

[See sub-rule (1) of rule 21AB]

Information to be provided under sub-section (5) of section 90 or sub-section (5) of section 90A of the Income-tax Act, 1961

I..... son/daughter of Mr in the capacity of.....
(Designation) do provide the following information, relevant to the previous year **2021-22** in case of for the purposes of sub-section (5) of section 90/section 90A:-

Sl.No.	Nature of information	Details
(i)	Status (individual; company, firm etc.) of the assessee	Company
(ii)	Permanent Account Number (PAN) of the assessee if allotted	
(iii)	Nationality (in the case of an individual) or Country or specified territory of incorporation or registration (in the case of others)
(iv)	Assessee's tax identification number in the country or specified territory of residence and if there is no such number, then, a unique number on the basis of which the person is identified by the Government of the country or the specified territory of which the assessee claims to be a resident

(v)	Period for which the residential status as mentioned in the certificate referred to in sub-section (4) of section 90 or sub-section (4) of section 90A is applicable	<u>2022-23</u>
(vi)	Address of the assessee in the country or territory outside India during the period for which the certificate, mentioned in (v) above, is applicable

I have obtained a certificate to in sub-section (4) of section 90 of sub-section (4) of section 90A from the Government of..... (name of country or specified territory outside India)

Signature:.....

Name:.....

Address:.....

Email ID:.....

Contact Number.....

Permanent Account Number:.....

Verification

I..... do hereby declare that to the best of my knowledge and belief what is stated above is correct complete and is truly stated. Verified today the..... day of.....

In case the M/s Bharat Heavy Electricals Limited, HPEP, Ramachandrapuram, Hyderabad is declared as an assessee in default due to any misstatement or incorrect declaration, we indemnify M/s Bharat Heavy Electricals Limited from any ensuing consequences thereunder.

Signature of the person providing the information

Place:.....

(On Company Letter Head)

No Business Connection or Permanent Establishment Certificate

Date

To

Bharat Heavy Electricals Limited
Ramachandrapuram, Hyderabad
India - 502032

Sir,

Sub: No Business Connection or Permanent Establishment declaration for FY **2021-22**

This is to certify that (Name of the supplier) is a company incorporated in(country) and does not have any business connection in India as per the provision of Section 9 of the Income Tax Act 1961 or any Permanent Establishment as defined in Article 5 of the India and(country) DTAA.

We hereby certify that we will notify BHEL in case of any change in the status as certified above.

For

Authorised Signatory

(Note – Please refer definition of the Business Connection on reverse and Permanent Establishment in the relevant DTAA)

"Business connection" as defined in Section 9 of the Income Tax Act shall include any business activity carried out through a person who, acting on behalf of the non-resident,—

- (a) has and habitually exercises in India, an authority to conclude contracts on behalf of the non-resident or habitually concludes contracts or habitually plays the principal role leading to conclusion of contracts by that non-resident and the contracts are—
 - (i) in the name of the non-resident; or
 - (ii) for the transfer of the ownership of, or for the granting of the right to use, property owned by that non-resident or that non-resident has the right to use; or
 - (iii) for the provision of services by the non-resident; or
- (b) has no such authority, but habitually maintains in India a stock of goods or merchandise from which he regularly delivers goods or merchandise on behalf of the non-resident; or
- (c) habitually secures orders in India, mainly or wholly for the non-resident or for that non-resident and other non-residents controlling, controlled by, or subject to the same common control, as that non-resident:

Provided that such business connection shall not include any business activity carried out through a broker, general commission agent or any other agent having an independent status, if such broker, general commission agent or any other agent having an independent status is acting in the ordinary course of his business :

Provided further that where such broker, general commission agent or any other agent works mainly or wholly on behalf of a non-resident (hereafter in this proviso referred to as the principal non-resident) or on behalf of such non-resident and other non-residents which are controlled by the principal non-resident or have a controlling interest in the principal non-resident or are subject to the same common control as the principal non-resident, he shall not be deemed to be a broker, general commission agent or an agent of an independent status

For the removal of doubts, it is hereby clarified with explanation-2A, that the significant economic presence of a non-resident in India shall constitute "business connection" in India and "significant economic presence" for this purpose, shall mean—

- (a) transaction in respect of any goods, services or property carried out by a non-resident in India including provision of download of data or software in India, if the aggregate of payments arising from such transaction or transactions during the previous year exceeds such amount as may be prescribed; or
- (b) systematic and continuous soliciting of business activities or engaging in interaction with such number of users as may be prescribed, in India through digital means:

Provided that the transactions or activities shall constitute significant economic presence in India, whether or not,—

- (i) the agreement for such transactions or activities is entered in India; or
- (ii) the non-resident has a residence or place of business in India; or
- (iii) the non-resident renders services in India:

Thresholds for the purposes of significant economic presence.

11UD. (1) For the purposes of clause (a) of Explanation 2A to clause (i) of sub-section (1) of section 9, the amount of aggregate of payments arising from transaction or transactions in respect of any goods, services or property carried out by a non-resident with any person in India, including provision of download of data or software in India during the previous year, shall be two crore rupees;

(2) For the purposes of clause (b) of Explanation 2A to clause (i) of sub-section (1) of section 9, the number of users with whom systematic and continuous business activities are solicited or who are engaged in interaction shall be three lakhs.

INTEGRITY PACT**Between**

Bharat Heavy Electricals Ltd. (BHEL), a company registered under the Companies Act 1956 and having its registered office at "BHEL House", Siri Fort, New Delhi - 110049 (India) hereinafter referred to as "The Principal", which expression unless repugnant to the context or meaning hereof shall include its successors or assigns of the ONE PART

and

_____, (description of the party along with address), hereinafter referred to as "The Bidder/ Contractor" which expression unless repugnant to the context or meaning hereof shall include its successors or assigns of the OTHER PART

Preamble

The Principal intends to award, under laid-down organizational procedures, contract/s for _____

_____ (hereinafter referred to as "Contract"). The Principal values full compliance with all relevant laws of the land, rules and regulations, and the principles of economic use of resources, and of fairness and transparency in its relations with its Bidder(s)/ Contractor(s).

In order to achieve these goals, the Principal will appoint panel of Independent External Monitor(s) (IEMs), who will monitor the tender process and the execution of the contract for compliance with the principles mentioned above.

Section 1- Commitments of the Principal

- 1.1 The Principal commits itself to take all measures necessary to prevent corruption and to observe the following principles: -
 - 1.1.1 No employee of the Principal, personally or through family members, will in connection with the tender for, or the execution of a contract, demand, take a promise for or accept, for self or third person, any material or immaterial benefit which the person is not legally entitled to.
 - 1.1.2 The Principal will, during the tender process treat all Bidder(s) with equity and reason. The Principal will in particular, before and during the tender process, provide to all Bidder(s) the same information and will not provide to any Bidder(s) confidential/ additional information through which the Bidder(s) could obtain an advantage in relation to the tender process or the contract execution.
 - 1.1.3 The Principal will exclude from the process all known prejudiced persons.
- 1.2 If the Principal obtains information on the conduct of any of its employees which is a penal offence under the Bharatiya Nyaya Sanhita (BNS) 2023 and Prevention of Corruption Act 1988 or any other statutory penal enactment, or if there be a substantive suspicion in this regard, the Principal will inform its Vigilance Office and in addition can initiate disciplinary actions.

Section 2 - Commitments of the Bidder(s)/ Contractor(s)

- 2.1 The Bidder(s)/ Contractor(s) commit himself to take all measures necessary to prevent corruption. The Bidder(s)/ Contractor(s) commits himself to observe the following principles during participation in the tender process and during the contract execution.

- 2.1.1 The Bidder(s)/ Contractor(s) will not, directly or through any other person or firm, offer, promise or give to the Principal or to any of the Principal's employees involved in the tender process or the execution of the contract or to any third person any material, immaterial or any other benefit which he/ she is not legally entitled to, in order to obtain in exchange any advantage of any kind whatsoever during the tender process or during the execution of the contract.
- 2.1.2 The Bidder(s)/ Contractor(s) will not enter with other Bidder(s) into any illegal or undisclosed agreement or understanding, whether formal or informal. This applies in particular to prices, specifications, certifications, subsidiary contracts, submission or non-submission of bids or any other actions to restrict competitiveness or to introduce cartelization in the bidding process.
- 2.1.3 The Bidder(s)/ Contractor(s) will not commit any penal offence under the relevant Bharatiya Nyaya Sanhita (BNS) and Prevention of Corruption Act; further the Bidder(s)/ Contractor(s) will not use improperly, for purposes of competition or personal gain, or pass on to others, any information or document provided by the Principal as part of the business relationship, regarding plans, technical proposals and business details, including information contained or transmitted electronically.
- 2.1.4 Foreign Bidder(s)/ Contractor(s) shall disclose the name and address of agents and representatives in India and Indian Bidder(s)/ Contractor(s) to disclose their foreign principals or associates. The Bidder(s)/ Contractor(s) will, when presenting his bid, disclose any and all payments he has made, and is committed to or intends to make to agents, brokers or any other intermediaries in connection with the award of the contract.
- 2.2 The Bidder(s)/ Contractor(s) will not instigate third persons to commit offences outlined above or be an accessory to such offences.
- 2.3 The Bidder(s)/ Contractor(s) shall not approach the Courts while representing the matters to IEMs and shall await their decision in the matter.

Section 3 - Disqualification from tender process and exclusion from future contracts

If the Bidder(s)/ Contractor(s), before award or during execution has committed a transgression through a violation of Section 2 above, or acts in any other manner such as to put his reliability or credibility in question, the Principal is entitled to disqualify the Bidder(s)/ Contractor(s) from the tender process, terminate the contract, if already awarded, exclude from future business dealings and/ or take action as per the separate "Guidelines on Banning of Business dealings with Suppliers/ Contractors", framed by the Principal.

Section 4 - Compensation for Damages

- 4.1 If the Principal has disqualified the Bidder (s) from the tender process before award / order acceptance according to Section 3, the Principal is entitled to demand and recover the damages equivalent to Earnest Money Deposit/ Bid Security.
- 4.2 If the Principal is entitled to terminate the Contract according to Section 3, or terminates the Contract in application of Section 3 above, the Bidder(s)/ Contractor (s) transgression through a violation of Section 2 above shall be construed breach of contract and the Principal shall be entitled to demand and recover from the Contractor an amount equal to 5% of the contract value or the amount equivalent to Security Deposit/ Performance Bank Guarantee, whichever is higher, as damages, in addition to and without prejudice to its right to demand and recover compensation for any other loss or damages specified elsewhere in the contract.

Section 5 - Previous Transgression

- 5.1 The Bidder declares that no previous transgressions occurred in the last 3 (three) years (to be reckoned from date of bid submission) with any other company in any country conforming to the anti-corruption approach in India that could justify his exclusion from the tender process. The date of such transgression, for the purpose of disclosure by the bidders in this regard, would be the date on which cognizance of the said transgression was taken by the competent authority. The transgression(s), for which cognizance was taken even before the said period of three years, but are pending conclusion, shall also be reported by the bidders.
- 5.2 If the Bidder makes incorrect statement on this subject, he can be disqualified from the tender process or the contract, if already awarded, can be terminated for such reason or action can be taken as per the separate "Guidelines on Banning of Business dealings with Suppliers/ Contractors", framed by the Principal.

Section 6 - Equal treatment of all Bidder (s)/ Contractor (s) / Sub-contractor (s)

- 6.1 The Principal will enter into Integrity Pacts with identical conditions as this Integrity Pact with all Bidders and Contractors.
- 6.2 In case of a joint venture, all the partners of the joint venture should sign the Integrity Pact. In case of Sub-contracting, the Principal Contractor shall be solely responsible for the adherence to the provisions of IP by the sub-contractor(s).
- 6.3 The Principal will disqualify from the tender process all Bidders who do not sign this Integrity Pact or violate its provisions.

Section 7 - Criminal Charges against violating Bidders/ Contractors /Subcontractors

If the Principal obtains knowledge of conduct of a Bidder, Contractor or Subcontractor, or of an employee or a representative or an associate of a Bidder, Contractor or Subcontractor which constitutes corruption, or if the Principal has substantive suspicion in this regard, the Principal will inform the Vigilance Office.

Section 8 -Independent External Monitor(s)

- 8.1 The Principal appoints competent and credible panel of Independent External Monitor (s) (IEMs) for this Integrity Pact. The task of the IEMs is to review independently and objectively, whether and to what extent the parties comply with the obligations under this Integrity Pact on receipt of any complaint by them from the bidder(s).
- 8.2 The IEMs are not subject to instructions by the representatives of the parties and performs his functions neutrally and independently. He reports to the CMD, BHEL.
- 8.3 The IEMs shall be provided access to all documents/ records pertaining to the Contract, for which a complaint or issue is raised before them as and when warranted. However, the documents/records/information having National Security implications and those documents which have been classified as /Top Secret are not to be disclosed.
- 8.4 The Principal will provide to the IEMs sufficient information about all meetings among the parties related to the Contract provided such meetings could have an impact on the contractual relations between the Principal and the Contractor. The parties offer to the IEMs the option to participate in such meetings.
- 8.5 The role of IEM is advisory and the advice of IEM is non-binding on the Organization. However, as IEMs are invariably persons with rich experience who have retired as senior functionaries of the government, their advice would help in proper implementation of the IP.

- 8.6 For ensuring the desired transparency and objectivity in dealing with the complaints arising out of the tendering process, the matter should be examined by the full panel of IEMs jointly, who would look into the records, conduct an examination, and submit their joint recommendations to the Management. In case the full panel is not available due to some unavoidable reasons, the available IEM(s) will conduct examination of the complaints. Consent of the IEM(s), who may not be available, shall be taken on record.
- 8.7 The IEMs shall examine all the representations/grievances/ complaints received by them from the bidders or their authorized representative related to any discrimination on account of lack of fair play in modes of procurement and bidding systems, tendering method, eligibility conditions, bid evaluation criteria, commercial terms & conditions, choice of technology/ specifications etc.
- 8.8 The CMD, BHEL shall decide the compensation to be paid to the IEMs and its terms and conditions.
- 8.9 IEMs should examine the process integrity, they are not expected to concern themselves with fixing of responsibility of officers. Complaints alleging mala fide on the part of any officer of the Principal should be looked into by the CVO of the Principal.
- 8.10 If the IEMs have reported to the CMD, BHEL, a substantiated suspicion of an offence under relevant Bharatiya Nyaya Sanhita (BNS)/ Prevention of Corruption Act, and the CMD, BHEL has not, within reasonable time, taken visible action to proceed against such offence or reported it to the Vigilance Office, the IEMs may also transmit this information directly to the Central Vigilance Commissioner, Government of India.
- 8.11 After award of work, the IEMs shall look into any issue relating to execution of Contract, if specifically raised before them. As an illustrative example, if a Contractor who has been awarded the Contract, during the execution of Contract, raises issue of delayed payment etc. before the IEMs, the same shall be examined by the panel of IEMs.
- 8.12 However, the IEMs may suggest systemic improvements to the management of the Principal, if considered necessary, to bring about transparency, equity and fairness in the system of procurement.
- 8.13 The word 'Monitor' would include both singular and plural.

Section 9 - Pact Duration

- 9.1 This Integrity Pact shall be operative from the date this Integrity Pact is signed by both the parties. Any violation of the same would entail disqualification of the bidders and exclusion from future business dealings.
- 9.2 If any claim is made/ lodged during currency of this Integrity Pact, the same shall be binding and continue to be valid despite the lapse of this Pact as specified above, unless it is discharged/ determined by the CMD, BHEL.

Section 10 - Other Provisions

- 10.1 This Integrity Pact is subject to Indian Laws and exclusive jurisdiction shall be of the competent Courts as indicated in the Tender or Contract, as the case may be.
- 10.2 Changes and supplements as well as termination notices need to be made in writing.

Integrity Pact (IP)

(a) IP is a tool to ensure that activities and transactions between the Company and its Bidders/ Contractors are handled in a fair, transparent and corruption free manner. Following Independent External Monitors (IEMs) on the present panel have been appointed by BHEL with the approval of CVC to oversee implementation of IP in BHEL.

Sl	IEM	Email
1.	Dr. Sarat Kumar Acharya, Ex-CMD, NLC	iem1@bhel.in
2.	Shri R. Mukundan, IRPS (Retd.)	iem2@bhel.in
3.	Shri Madan Lal Meena, IAS (Retd.)	iem3@bhel.in

(b) The IP as enclosed with the tender is to be submitted (duly signed by authorized signatory) along with techno-commercial bid (Part-I, in case of two/ three part bid). Only those bidders who have entered into such an IP with BHEL would be competent to participate in the bidding. In other words, entering into this Pact would be a preliminary qualification.

(c) Please refer Section-8 of IP for Role and Responsibilities of IEMs. In case of any complaint arising out of the tendering process, the matter may be referred to the panel of IEMs. All correspondence with the IEMs shall be done through email only.

Note:

No routine correspondence shall be addressed to the IEM (phone/ post/ email) regarding the clarifications, time extensions or any other administrative queries, etc on the tender issued. All such clarification/ issues shall be addressed directly to the tender issuing (procurement) department's officials whose contact details are provided below:

Details of contact person(s):

Name: Arief Ahmed Choudhury
 Deptt: Purchase(HE&F)
 Address: Admin Building Room no.222
 Phone (Landline/ Mobile): 040-23182407
 Email:arief@bhel.in

Name: Ashish Ranjan
 Deptt: Purchase(HE&F)
 Address: Admin Building Room no.222
 Phone (Landline/ Mobile): 040-2318 4659
 Email: ashuraj @bhel.in