



**BHARAT HEAVY ELECTRICALS LTD.**  
 (A GOVT. OF INDIA UNDERTAKING)  
 P.O BHEL Jhansi - 284129, INDIA  
 Tel.:0510-277001/2412260 Fax: 2412120  
 Email : mmx@bheljhs.co.in

**PURCHASE ENQUIRY**

ENQ NO/DT: E1800031 05/04/21  
 REV NO/DT: 5 08/06/22

PAGE 1/6

OUR ABOVE ENQUIRY OF PREVIOUS REV & DATE IS AMENDED WITH FOLLOWING CHANGED / ADDED ITEMS.	
Eng Due on:	08-07-22 FRIDAY
Close at:	13:15 Open at:14:00
Matcat:	181004 RIP BUSHING
Validity:	120 days from Technical bid opening date
ITEM:	
TOP:	See Special Remarks
REQUIRED: TEST CERT/ GUARANTEE CERT	RA: BHEL reserves the right to conduct RA
Est. Value:	Item wise
Bid Type:	TWO BID
Tot Item:	2
Delivery:	FOR Jhansi
E-Proc:	No

ITEM NO : 1 PSL QTY/UM: 6.00 NO  
 MATL CODE : TR172225C605 PO QTY /UM: 6.00 NO  
 DESTINATION: JS

DESCRIPTION	DELIVERY	QUANTITY (PSL UM)
245 K.V.1250 AMPS 300 CT SPACE RIP H.V.BUSHING AS PER ATTACHD ANNEXURE.	JUN-22	6.00

ITEM NO : 2 PSL QTY/UM: 6.00 NO  
 MATL CODE : TR172225C605 PO QTY /UM: 6.00 NO  
 DESTINATION: JS

DESCRIPTION	DELIVERY	QUANTITY (PSL UM)
145KV.1250AMP.300 CT SPACE RIP IV BUSHING AS PER ATTACHED ANNEXURE.	JUN-22	6.00

**SPECIAL REMARKS:**

- REV 05 IS BEING ISSUED TO RE-FLOATE THE ENQUIRY WITH DUE DATE 24.06.2022.REMARKS AMENDED FOR FLOATING ENQUIRY ON NIC.
- REV 04 NOT ISSUED.
- REV 03 IS BEING ISSUED TO RE-FLOATE THE ENQUIRY WITH DUE DATE 03.08.2021.
- REV 02 IS BEING ISSUED TO RE-FLOATE THE ENQUIRY WITH DUE DATE 09.07.21.
- REV 01 IS BEING ISSUED TO EXTEND THE DUE DATE 27.04.21.

XX  
 XXX

1. ENQUIRY IS FLOATED IN TWO BID SYSTEM THRU E-PROCUREMENT (<https://eprocurebhel.co.in>) TO PROCURE THE ITEM MENTIONED IN THE DESCRIPTION.
2. TECHNICAL- COMMERCIAL MANDATORY SHEET AND TECHNICAL SPECIFICATION IS UPLOADED AT OUR E-PROCUREMENT PORTAL i.e <https://eprocurebhel.co.in>. ANY DEVIATIONS SHALL BE CLEARLY MENTIONED IN THE TECHNICAL BID ITSELF.DEVIATION SHEETS CAN BE ATTACHED SEPARATELY.
3. SUBMISSION OF TENDER DOCUMENTS THROUGH OTHER THAN E-PROCUREMENT MODE SHALL NOT BE ACCEPTED.
4. PLEASE QUOTE WITH FIRM RATES OTHERWISE OFFER WILL BE BY-PASSED.
5. GUARANTEE AND TEST CERTIFICATE IS REQUIRED IN TRIPLICATE ALONGWITH EACH SUPPLY.
6. TYPE TEST REPORT TO BE SUBMITTED ALONG WITH THE OFFER WHICH IS NOT OLDER THAN FIVE YEARS.
7. DRAWING WITH DETAILS SHALL BE SUBMITTED ALONGWITH OFFER. PLEASE

RL



BHARA HEAVY ELECTRICALS LTD.  
 (A GOVT. OF INDIA UNDERTAKING)  
 P.O BHEL Jhansi - 284129, INDIA  
 Tel.:0510-277001/2412260 Fax: 2412120  
 Email : mmx@bheljhs.co.in

PURCHASE ENQUIRY

ENQ NO/DT: E1800031 05/04/21  
 REV NO/DT: 5 08/06/22

PAGE 2  
6

JSC140/M2053

- SUBMIT DRAWINGS ALONGWITH TECHNO - COMMERCIAL OFFER.
8. ALL THE TERMS AND CONDITIONS OF THE CONTRACT WITH RESPECT TO TAXES AND DUTIES ARE SUBJECT TO THE NEW TAXATION LAWS (E.G. GST). THE TERMS AND CONDITIONS WILL BE MODIFIED IN ACCORDANCE WITH THE PROVISIONS OF NEW LAWS E.G. GST.
  9. TWO YEAR SUCCESSFUL PERFORMANCE CERTIFICATE SHALL HAVE TO BE PROVIDED.DRAWINGS AND ALL RELEVANT DOCUMENTS TO BE SUBMITTED BY BIDDERS FOR CUSTOMER APPROVAL.
  - 10.OFFER OF UPPTCL APPROVED SUPPLIERS WILL ONLY BE CONSIDERED IN THE ENQUIRY.SUPPLIER HAS TO SUBMIT UNAMBIGUOUS VENDOR APPROVAL WITH OFFER.
  - 11.SUCCESSFUL VENDOR TO START MANUFACTURING ONLY AFTER DRAWING APPROVAL FROM CUSTOMER.
  - 12.LOADING SHALL BE APPLICABLE FOR NON ACCEPTANCE OF NIT TERMS AND CONDITIONS.
  - 13.INSPECTION BY BHEL AT JHANSI.
  - 14.EVALUTION SHALL BE ON ENQUIRY ITEM WISE BASIS.
  - 15.BHEL SHALL BE RESORTING TO REVERSE AUCTION (RA) (GUIDELINES AS AVAILABLE ON WWW.BHEL.COM) FOR THIS TENDER. RA SHALL BE CONDUCTED AMONG THE TECHNO-COMMERCIALY QUALIFIED BIDDERS. PRICE BIDS OF ALL TECHNO-COMMERCIALY QUALIFIED BIDDERS SHALL BE OPENED AND SAME SHALL BE CONSIDERED FOR RA. IN CASE ANY BIDDER(S) DO(ES) NOT PARTICIPATE IN ONLINE REVERSE AUCTION, THEIR SEALED ENVELOPE PRICE BID ALONG WITH APPLICABLE LOADING, IF ANY, SHALL BE CONSIDERED FOR RANKING.
  - 16.ENQUIRY IS FLOATED AS GLOBAL OPEN TENDER.

THE QUOTATION MUST BE SEALED AND BE SENT IN DOUBLE ENVELOPE.

THE INNER ENVELOPE SHOULD BEAR ENQUIRY NUMBER & DUE DATE AT THE TOP.

In case the bidder has not submitted PAN No, TIN No. and E-mail ID, the bidder has to submit the same along with the copy of PAN No and TIN No. Else his offer will be liable to be rejected.

If you are not in a position to quote due to any reason, you must send regret letter titled enquiry no. etc, failing which you may not be considered for sending future enquiries.

\*\*\*\*\*

ENCLOSERS:

26



BHARAT HEAVY ELECTRICALS LTD.  
(A GOVT. OF INDIA UNDERTAKING)  
P.O BHEL Jhansi - 284129, INDIA  
Tel.:0510-277001/2412260 Fax: 2412120  
Email : mmx@bheljhs.co.in

## PURCHASE ENQUIRY

ENQ NO/DT: E1800031 05/04/21  
REV NO/DT: 5 08/06/22

PAGE 3  
6

FOR AND ON BEHALF OF  
BHARAT HEAVY ELECTRICALS LTD

*RH*  
08/06/22  
RAHUL KUMAR  
DY MANAGER (TRFR MM)  
Email:-rahulkumar.r@bhel.in

\* \* \* \* \* E N D O F P U R C H A S E E N Q U I R Y \* \* \* \* \*

### NOTE :

- \* THE BIDDER IS INFORMED THAT THE GENERAL TERMS & CONDITIONS OF ENQUIRY (JHS 2055A Rev 03) WHICH ARE UPLOADED AT <https://www.bheljhs.co.in/apps/sip/index.php> AT (TERMS & CONDITION -> FOR ENQUIRY ) LINK, ARE TO BE READ BY THE BIDDER BEFORE SUBMITTING QUOTE IN THE ENQUIRY. BHEL SHALL CONSTRU THE PARTICIPATION BY THE BIDDER IN ENQUIRY AS ACCEPTANCE TO THE GENERAL TERMS AND CONDITIONS OF ENQUIRY.
- \* SUPPLIERS ARE REQUESTED TO INFORM US WITH VALID CERTIFICATE, IF THEY ARE REGISTERED UNDER MSMED ACT'2006.(APPLICABLE FOR INDIAN SUPPLIERS ONLY).
- \* FOR SUPPLIERS SUPPLYING FROM OUTSIDE THE LOCAL AREA OF BHEL JHANSI, ENTRY TAX WILL BE APPLICABLE.SUPPLIERS SHOULD NECESSARILY INDICATE RATE OF ENTRY TAX SEPARATELY WHEREVER APPLICABLE.THEY SHOULD ALSO MENTION THE ENTRY TAX CHARGED SAPARATELY IN THE INVOICE.
- \* FOR SUPPLIERS SUPPLYING FROM OUTSIDE UP, IN CASE THE OFFER IS SILENT ON ENTRY TAX, IT SHALL BE LOADED SUITABLY WITH THE APPLICABLE RATES
- \* IN CASE IF THERE IS ANY DIFFERENCE BETWEEN THE 'SPECIAL REMARKS/ANNEXURES' OF THE ENQUIRY AND THE PREPRINTED TERMS & CONDITIONS (REF JSC140/M2053), THE REQUIREMENT GIVEN IN REMARKS WILL PREVAIL.
- \* Reference Sl. No. 2(B) of General Terms and Conditions regarding option for offer submission through Email addressed to tenderbox.jhs@bhel.in , please note that the maximum mail size including attachments should not exceed 20 MB , otherwise the offer shall not be delivered due to size limitation and bidder sending mail attachments more than 20 MB will have no claim whatsoever on the subject tender . Also due to any technical snag , if offer has not reached tenderbox.jhs@bhel.in , it will be bidder's sole responsibility to ensure offer submission through alternate routes before the due date and time .BHEL will not entertain any such claim for non-receipt of offer on time .

*RH*

**Acceptance to salient Terms & Conditions of the Enquiry E1800031 i.e. Techno Commercial Bid**

*Important : This format is to be submitted in original, along with Part-A of bid, duly signed by the bidders, as proof of acceptance.*

Sl.No	DESCRIPTION	TO BE FILLED BY THE VENDOR
A-	Name of the Supplier with Telephone No./Fax No./Email	
B-	Name and Designation of Contact person	
C-	Address of the works at which inspection/delivery is offered.	

Sl. no.	Particulars	Supplier's Confirmation
1-	Complete acceptance to Technical terms & conditions including Technical/Purchase Specs as mentioned in ENQUIRY	<input type="checkbox"/> Accepted
2-	Participation by the Bidders in the tender shall be construed as acceptance of the bidder to the General Terms and Conditions JHS2055A-Rev-03 uploaded at <a href="https://jhs.bhel.com/apps/sip/enq_terms/enq_tems_current.pdf">https://jhs.bhel.com/apps/sip/enq_terms/enq_tems_current.pdf</a>  We confirm that we have read the GTC with applicable revision, and accepts the same.	<input type="checkbox"/> Accepted
3-	Acceptance for finalization of price bid Part-B through online Bidding (Reverse Auction)	<input type="checkbox"/> Accepted
4-	Conformance / Test Certificate/Guarantee Certificate (along with supply) as specified in enquiry will be provided.	<input type="checkbox"/> Yes
5-	(a) <b>Delivery</b> period on FOB/CIF, /FOR basis from date of PO issue/Drawing approval, whichever is later.  (b) Vendor to indicate their monthly capacity /Supply rate also.  (c) Supplier shall have minimum monthly capacity of total 20 Tonnes reserved for BHEL.	.....Days.  <input type="checkbox"/> Accepted  <input type="checkbox"/> Accepted

*2*

6-	<b>Taxes and Duties (For indigenous bidders only):</b> -Extra as applicable.  a). CGST (Mention N.A if not applicable)  b). SGST (Mention N.A if not applicable)  c). IGST (Mention N.A if not applicable)	<input type="checkbox"/> Accepted  a).....%  b).....%  c).....%
7-	<b>Taxes and Duties (For Foreign bidders only):</b> -All taxes and duties in their country will be borne by them only and in India same shall be to BHEL account. Refer GTC (JHS2055A-Rev-03) for more detail and same shall prevail.	<input type="checkbox"/> Accepted
8-	<b>Price Bid</b> submitted as per attached price bid format only (Copy of blank price Bid is submitted).	<input type="checkbox"/> Accepted
9-	<b>Acceptance for prices on firm basis and no PVC is applicable.</b>	<input type="checkbox"/> Accepted
10-	<b>Acceptance for prices finalization through reverse auction (R.A) i.e. Acceptance to participation in R.A</b>	<input type="checkbox"/> Accepted
11-	a). <b>Terms of delivery on F.O.R BHEL Jhansi basis</b> (for indigenous bidders).  b). <b>Terms of delivery on F.O.B Load Port basis or CIF, basis.</b> (For Foreign bidders) (Pl mention name of Load Port)	<input type="checkbox"/> Accepted
12-	<b>Validity</b> - Quoted prices are valid for 120 days from date of tender opening.	<input type="checkbox"/> Accepted
13-	<b>Payment Terms (For indigenous bidders) -</b> 100 % payment within 90 days (45 days for MSE / NSIC registered suppliers as per relevant act in force) from the date of receipt of material and submission of clear and admissible bill, subject to acceptance of material at BHEL, on direct presentation of the documents. In case of dispatch of material to site directly, site certification for receipt of materials is required unless otherwise provided for in the PO. Any deviation from the above payment terms, if accepted (by BHEL), shall be loaded @ SBI base rate (as on date of Part I bid opening) + 6%, for the purpose of bid evaluation.	<input type="checkbox"/> Accepted  <input type="checkbox"/> Accepted

14-	<p><b>Terms of payment (For Foreign Bidders): -</b>  Our Standard Payment terms is:</p> <p>(i) 100% Payment through CAD or  (ii) 100% payment will be considered by irrevocable and unconfirmed Usance LC with 120 days' interest free credit, to be reckoned from the date of Bill of Lading</p> <p>In case of request for confirmed LC, confirmation charges shall be borne by the vendor.</p>	<p>(i) <input type="checkbox"/> Accepted  (ii) <input type="checkbox"/> Accepted</p>
15-	No <b>Advance payment</b> terms will be accepted.	<input type="checkbox"/> Accepted
16-	<b>Liquidated Damage / Penalty</b> - Failure to supply by the time specified in the order will make the supplier liable to pay unconditional penalty of 1/2% of the price of the goods in arrear (delayed and not supplied) per week or part thereof, subject to a maximum of 10% of the order value unless agreed otherwise.	<input type="checkbox"/> Accepted
17-	<b>Risk Purchase</b> - If the material is not supplied within stipulated delivery indicated in PO, BHEL shall have the option to purchase the material from other sources at the supplier's risk & cost.	<input type="checkbox"/> Accepted
18-	<b>Guarantee:</b> In Case an order is placed, supplier shall be required to guarantee for smooth and satisfactory performance of the equipment for a period of 24 months from the date of dispatch or 18 months from the date of commissioning whichever is later and certificate must be issued to this effect. Necessary instruction booklets for operation and maintenance are to be sent with supply, where applicable.	<input type="checkbox"/> Accepted
19-	Please furnish shipping Dimension & Weight of consignment in your offer.(For Foreign Suppliers)	No. of package ----- Dimension of each package 1- Length ----- 2- Width ----- 3- Height ----- 4- Weight -----
20-	"The Bidder along with its associate/collaborators/sub-contractors/sub-vendors/consultants/service providers shall strictly adhere to BHEL Fraud prevention Policy displayed on BHEL website <a href="http://www.bhel.com">http://www.bhel.com</a> and shall immediately bring to the notice of BHEL management about any fraud or suspected fraud as soon as it comes to their notice."	<input type="checkbox"/> Accepted
21	a) For Foreign Bidders-No. of days to generate Bill of Lading after dispatch clearance.	.....Days

	b) For Indigenous bidders- No of days to reach the material to BHEL, Jhansi after Dispatch clearance.	.....Days
22	For Indigenous Supplier, supplier has to provide 15 Days advance intimation for inspector deputation on vendor works. Further dispatch clearance will be given within 4 days of submission of report to BHEL/CUSTOMER. Vendor to take care of other elements of inspection such as Inspection duration, Inspection report submission, arrangement of Packing, transportation duration from Supplier works to BHEL Jhansi etc. to meet delivery dates of PO . For foreign suppliers, supplier has to provide advance intimation of 45 days. All other things will be same as mentioned above.	<input type="checkbox"/> Accepted  <input type="checkbox"/> Accepted
23	Delivery period from LC Opening date. (For Foreign Suppliers) (In case payment through LC, should preferably be 60 days from LC opening date.)	.....Days.

**Signature of Supplier & seal** : .....

**Date** : .....

**Name of contact person** : .....

**Cell No.** : .....

**Landline with STD code & E-mail** : .....

902

### **ANNEXURE-A Specification of RIP Bushing**

- 1.1 RIP Bushing shall be Oil to Air type intended to be used with one side immersed in oil and other in ambient air. Bushing housing shall be with composite insulator. Bushing shall be interchangeable with the existing bushing in service. Mounting detail & Connection arrangement shall be reviewed during detail engineering.
- 1.2 Bushings shall be robust and designed for adequate cantilever strength to meet the requirement of seismic condition, substation layout and movement along with the spare Transformer with bushing erected and provided with proper support from one foundation to another foundation within the substation area. The electrical and mechanical characteristics of bushings shall be in accordance with IEC: 60137/DIN 42530. All details of the bushing shall be submitted for approval.
- 1.3 RIP type bushing shall be provided with tap for capacitance and tan delta test. Test taps relying on pressure contacts against the outer earth layer of the bushing is not acceptable.
- 1.4 Clamps and fittings shall be of hot dip galvanised/stainless steel.
- 1.5 No arcing horns shall be provided on the bushings.
- 1.6 Polymer / composite insulator shall be seamless sheath of a silicone rubber compound. The housing & weather sheds should have silicon content of minimum 30% by weight. It should protect the bushing against environmental influences, external pollution and humidity. The interface between the housing and the core must be uniform and without voids. The strength of the bond shall be greater than the tearing strength of the polymer. The manufacturer shall follow non-destructive technique (N.D.T.) to check the quality of jointing of the housing interface with the core. The technique being followed with detailed procedure and sampling shall be finalized during finalization of MQP.

The weather sheds of the insulators shall be of alternate shed profile as per IEC 60815-3. The weather sheds shall be vulcanized to the sheath (extrusion process) or moulded as part of the sheath (injection moulding process) ,free from imperfections and should be seamless single piece. Any seams / burrs protruding axially along the insulator, resulting from the injection moulding process shall be removed completely without causing any damage to the housing. The track resistance of housing and shed material shall be class 1A4.5 according to IEC60587. The strength of the weather shed to sheath interface shall be greater than the tearing strength of the polymer. The composite insulator shall be capable of high pressure washing.

End fittings shall be free from cracks, seams, shrinks, air holes and rough edges.

SL

All surfaces of the metal parts shall be perfectly smooth with the projecting points or irregularities which may cause corona. All load bearing surfaces shall be smooth and uniform so as to distribute the loading stresses uniformly.

The hollow silicone composite insulators shall comply with the requirements of the IEC publications IEC 61462 , relevant parts of IEC 62217 and should be single piece. The design of the composite insulators shall be tested and verified according to IEC 61462 (Type & Routine test)

- 1.7 Installation procedures for the bushings shall be clearly brought out in the Instruction manual.
- 1.8 Measurement of capacitance and tan delta of RIP bushings: Tan delta value shall not be more than 0.4 % at ambient temperature. No Temperature correction factor shall be applicable.
- 1.9 The offered bushings should be type tested as per IEC 60137. The bidder shall submit the type test reports .
- 1.10 Bushing including accessories/ fittings etc shall be suitably packed in reusable covering box suitable for long storage. Packing Box opening cover with nails/ screws type packing arrangement shall not be acceptable. Suitable number of metal hinges shall be provided for sealing the top cover of the packing. Bushing oil end portion shall be fitted with metal housing with positive dry air pressure and a suitable pressure monitoring device shall be fitted on the metal housing during storage to avoid direct contact with moisture with epoxy. Alternatively, oil filled metal housing with suitable arrangement for taking care oil expansion due to temperature variations shall also be acceptable. All items shall be properly packed to avoid any damage in transit. Metal housing shall be provided for each bushing over air end to avoid any exposure to dirt/ rats etc. Manufacturer shall submit drawing/ documents of packing for approval during detail engineering. Detail method for storage of bushing including accessories shall be brought out in the instruction manual.
- 1.12 For the details of mounting and draw rod details, the drawing of existing 245 KV and 145 KV Bushings are attached.
- 1.13 Tan delta value shall be less than 0.4%.

24/03/2024  
 (KAUSHALENDRA SINGH)  
 Manager (Design) Trfr. Engg.  
 B.H.E.L., HANSI

24



First Angle Projection

DRG.No. 34630050164

All dimensions in mm

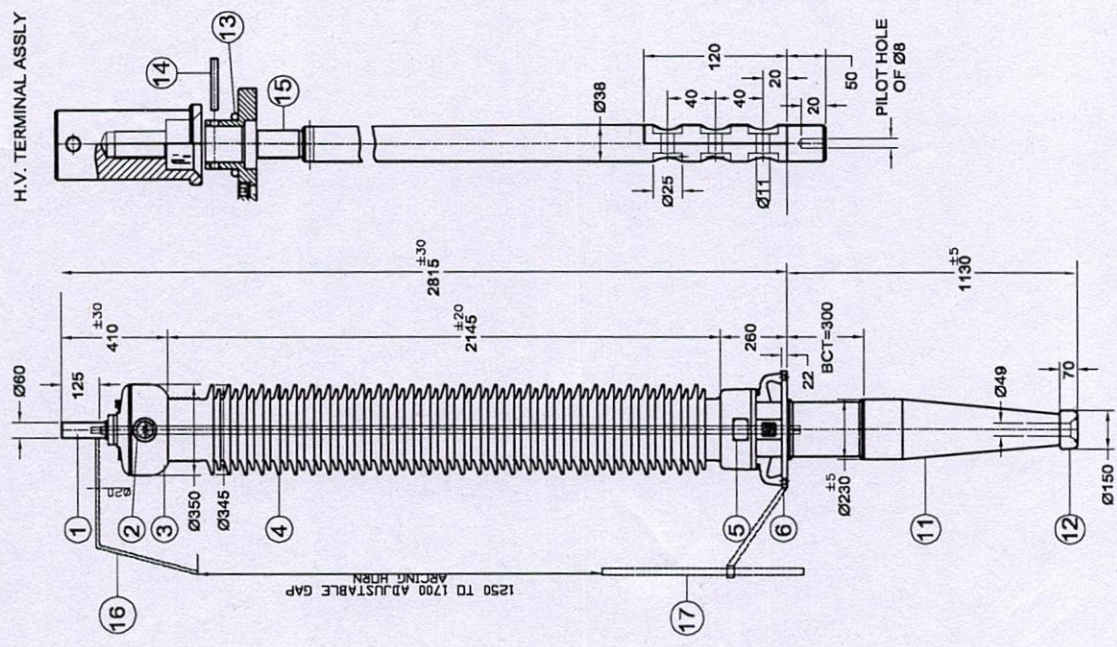

TEST TAP DETAIL

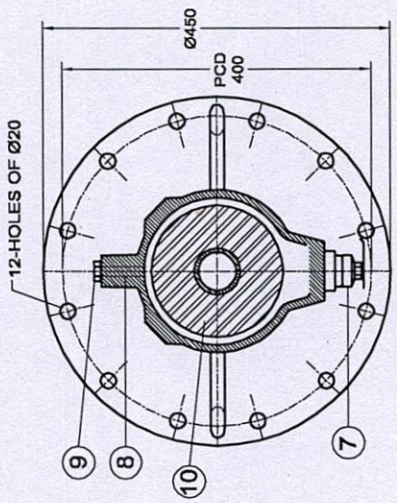
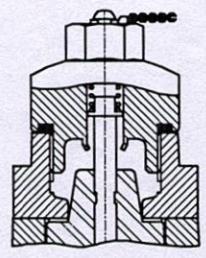

TECHNICAL DATA

TYPE:- OIL IMPREGNATED PAPER INSULATION, DRAW ROD TYPE

RATED VOLTAGE (L-L) = 245 KV

RATED VOLTAGE (L-E) = 142 KV

RATED CURRENT = 1250 AMP.

P.F. WITHSTAND VOLTAGE(DRY/WET) = 505/460 KV

L.I. / S.I. WITHSTAND VOLTAGE (DRY) = 1050/750 kVp

TOTAL CREEPAGE DISTANCE = 6125 mm

MAXIMUM ANGLE OF MOUNTING = MAX. 30° FROM VERTICAL

CANTILEVER WITHSTAND LOAD = 1600 N

RATED SHORT TIME CURRENT RATING = 40KA for 3 sec.

REFERENCE STANDARD = IS:2099;IEC:60137(2008)

TOTAL OIL WEIGHT = 50 Ltr.±10% TOTAL WEIGHT = 420 kg. ±10%

TYPE OF BUSHING = DRAW ROD

ITEM	QTY	DESCRIPTION	MATERIAL	FINISH
1	1	H.V. TERMINAL	BRASS	NICKEL PLATED
2	1	OIL INDICATOR(FLOAT)	BODY ALUMINIUM	PAINTED
3	1	CONSERVATOR	AL. ALLOY	PAINTED
4	1	AIR END INSULATOR	PORCELAIN	BROWN GLAZED
5	1	RATING PLATE	ALUMINIUM	PHOTOGRAPHIC
6	1	MOUNTING FLANGE	AL. ALLOY	PAINTED
7	1	TEST TAP ASSLY.	---	---
8	1	OIL FILLING/SAMPLING VALVE	STEEL	NICKEL PLATED
9	1	AIR VENT PLUG	BRASS	NICKEL PLATED
10	1	CONDENSER CORE	O.I.P.	---
11	1	OIL END INSULATOR	EPOXY	---
12	1	ELECTRODE	AL. ALLOY	PAINTED
13	1	SEALING RING	NITRILE	---
14	1	LOCKING PIN	STAINLESS STEEL	---
15	1	DRAW ROD	COPPER	NICKEL PLATED
16	1	UPPER ARCING HORN	M.S ST 42S	H.D.G
17	1	LOWER ARCING HORN	M.S ST 42S	H.D.G

REV	DATE	ALTERED	CHECKED	APPROVED	ZONE
00	17/05/2017	ALTERED	CHECKED	APPROVED	ZONE

REV	DATE	ALTERED	CHECKED	APPROVED	ZONE
00	17/05/2017	ALTERED	CHECKED	APPROVED	ZONE

REV	DATE	ALTERED	CHECKED	APPROVED	ZONE
00	17/05/2017	ALTERED	CHECKED	APPROVED	ZONE

REV	DATE	ALTERED	CHECKED	APPROVED	ZONE
00	17/05/2017	ALTERED	CHECKED	APPROVED	ZONE

REV	DATE	ALTERED	CHECKED	APPROVED	ZONE
00	17/05/2017	ALTERED	CHECKED	APPROVED	ZONE

REV	DATE	ALTERED	CHECKED	APPROVED	ZONE
00	17/05/2017	ALTERED	CHECKED	APPROVED	ZONE

REV	DATE	ALTERED	CHECKED	APPROVED	ZONE
00	17/05/2017	ALTERED	CHECKED	APPROVED	ZONE

REV	DATE	ALTERED	CHECKED	APPROVED	ZONE
00	17/05/2017	ALTERED	CHECKED	APPROVED	ZONE

REV	DATE	ALTERED	CHECKED	APPROVED	ZONE
00	17/05/2017	ALTERED	CHECKED	APPROVED	ZONE

REV	DATE	ALTERED	CHECKED	APPROVED	ZONE
00	17/05/2017	ALTERED	CHECKED	APPROVED	ZONE

REV	DATE	ALTERED	CHECKED	APPROVED	ZONE
00	17/05/2017	ALTERED	CHECKED	APPROVED	ZONE

REV	DATE	ALTERED	CHECKED	APPROVED	ZONE
00	17/05/2017	ALTERED	CHECKED	APPROVED	ZONE

REV	DATE	ALTERED	CHECKED	APPROVED	ZONE
00	17/05/2017	ALTERED	CHECKED	APPROVED	ZONE

REV	DATE	ALTERED	CHECKED	APPROVED	ZONE
00	17/05/2017	ALTERED	CHECKED	APPROVED	ZONE

REV	DATE	ALTERED	CHECKED	APPROVED	ZONE
00	17/05/2017	ALTERED	CHECKED	APPROVED	ZONE

REV	DATE	ALTERED	CHECKED	APPROVED	ZONE
00	17/05/2017	ALTERED	CHECKED	APPROVED	ZONE

REV	DATE	ALTERED	CHECKED	APPROVED	ZONE
00	17/05/2017	ALTERED	CHECKED	APPROVED	ZONE

REV	DATE	ALTERED	CHECKED	APPROVED	ZONE
00	17/05/2017	ALTERED	CHECKED	APPROVED	ZONE

REV	DATE	ALTERED	CHECKED	APPROVED	ZONE
00	17/05/2017	ALTERED	CHECKED	APPROVED	ZONE

REV	DATE	ALTERED	CHECKED	APPROVED	ZONE
00	17/05/2017	ALTERED	CHECKED	APPROVED	ZONE

REV	DATE	ALTERED	CHECKED	APPROVED	ZONE
00	17/05/2017	ALTERED	CHECKED	APPROVED	ZONE

REV	DATE	ALTERED	CHECKED	APPROVED	ZONE
00	17/05/2017	ALTERED	CHECKED	APPROVED	ZONE

REV	DATE	ALTERED	CHECKED	APPROVED	ZONE
00	17/05/2017	ALTERED	CHECKED	APPROVED	ZONE

REV	DATE	ALTERED	CHECKED	APPROVED	ZONE
00	17/05/2017	ALTERED	CHECKED	APPROVED	ZONE

REV	DATE	ALTERED	CHECKED	APPROVED	ZONE
00	17/05/2017	ALTERED	CHECKED	APPROVED	ZONE

REV	DATE	ALTERED	CHECKED	APPROVED	ZONE
00	17/05/2017	ALTERED	CHECKED	APPROVED	ZONE

REV	DATE	ALTERED	CHECKED	APPROVED	ZONE
00	17/05/2017	ALTERED	CHECKED	APPROVED	ZONE

REV	DATE	ALTERED	CHECKED	APPROVED	ZONE
00	17/05/2017	ALTERED	CHECKED	APPROVED	ZONE

REV	DATE	ALTERED	CHECKED	APPROVED	ZONE
00	17/05/2017	ALTERED	CHECKED	APPROVED	ZONE

REV	DATE	ALTERED	CHECKED	APPROVED	ZONE
00	17/05/2017	ALTERED	CHECKED	APPROVED	ZONE

REV	DATE	ALTERED	CHECKED	APPROVED	ZONE
00	17/05/2017	ALTERED	CHECKED	APPROVED	ZONE

REV	DATE	ALTERED	CHECKED	APPROVED	ZONE
00	17/05/2017	ALTERED	CHECKED	APPROVED	ZONE

REV	DATE	ALTERED	CHECKED	APPROVED	ZONE
00	17/05/2017	ALTERED	CHECKED	APPROVED	ZONE

REV	DATE	ALTERED	CHECKED	APPROVED	ZONE
00	17/05/2017	ALTERED	CHECKED	APPROVED	ZONE

REV	DATE	ALTERED	CHECKED	APPROVED	ZONE
00	17/05/2017	ALTERED	CHECKED	APPROVED	ZONE

REV	DATE	ALTERED	CHECKED	APPROVED	ZONE
00	17/05/2017	ALTERED	CHECKED	APPROVED	ZONE

REV	DATE	ALTERED	CHECKED	APPROVED	ZONE
00	17/05/2017	ALTERED	CHECKED	APPROVED	ZONE

REV	DATE	ALTERED	CHECKED	APPROVED	ZONE
00	17/05/2017	ALTERED	CHECKED	APPROVED	ZONE

REV	DATE	ALTERED	CHECKED	APPROVED	ZONE
00	17/05/2017	ALTERED	CHECKED	APPROVED	ZONE

REV	DATE	ALTERED	CHECKED	APPROVED	ZONE
00	17/05/2017	ALTERED	CHECKED	APPROVED	ZONE

REV	DATE	ALTERED	CHECKED	APPROVED	ZONE
00	17/05/2017	ALTERED	CHECKED	APPROVED	ZONE

REV	DATE	ALTERED	CHECKED	APPROVED	ZONE
00	17/05/2017	ALTERED	CHECKED	APPROVED	ZONE

REV	DATE	ALTERED	CHECKED	APPROVED	ZONE
00	17/05/2017	ALTERED	CHECKED	APPROVED	ZONE

REV	DATE	ALTERED	CHECKED	APPROVED	ZONE
00	17/05/2017	ALTERED	CHECKED	APPROVED	ZONE

REV	DATE	ALTERED	CHECKED	APPROVED	ZONE
00	17/05/2017	ALTERED	CHECKED	APPROVED	ZONE

REV	DATE	ALTERED	CHECKED	APPROVED	ZONE
00	17/05/2017	ALTERED	CHECKED	APPROVED	ZONE

REV	DATE	ALTERED	CHECKED	APPROVED	ZONE
00	17/05/2017	ALTERED	CHECKED	APPROVED	ZONE

REV	DATE	ALTERED	CHECKED	APPROVED	ZONE
00	17/05/2017	ALTERED	CHECKED	APPROVED	ZONE

REV	DATE	ALTERED	CHECKED	APPROVED	ZONE
00	17/05/2017	ALTERED	CHECKED	APPROVED	ZONE

REV	DATE	ALTERED	CHECKED	APPROVED	ZONE
00	17/05/2017	ALTERED	CHECKED	APPROVED	ZONE

REV	DATE	ALTERED	CHECKED	APPROVED	ZONE
00	17/05/2017	ALTERED	CHECKED	APPROVED	ZONE

REV	DATE	ALTERED	CHECKED	APPROVED	ZONE
00	17/05/2017	ALTERED	CHECKED	APPROVED	ZONE

REV	DATE	ALTERED	CHECKED	APPROVED	ZONE
00	17/05/2017	ALTERED	CHECKED	APPROVED	ZONE

REV	DATE	ALTERED	CHECKED	APPROVED	ZONE
00	17/05/2017	ALTERED	CHECKED	APPROVED	ZONE

REV	DATE	ALTERED	CHECKED	APPROVED	ZONE
00	17/05/2017	ALTERED	CHECKED	APPROVED	ZONE

REV	DATE	ALTERED	CHECKED	APPROVED	ZONE
00	17/05/2017	ALTERED	CHECKED	APPROVED	ZONE

REV	DATE	ALTERED	CHECKED	APPROVED	ZONE
00	17/05/2017	ALTERED	CHECKED	APPROVED	ZONE

REV	DATE	ALTERED	CHECKED	APPROVED	ZONE
00	17/05/2017	ALTERED	CHECKED	APPROVED	ZONE

REV	DATE	ALTERED	CHECKED	APPROVED	ZONE
00	17/05/2017	ALTERED	CHECKED	APPROVED	ZONE

REV	DATE	ALTERED	CHECKED	APPROVED	ZONE
00	17/05/2017	ALTERED	CHECKED	APPROVED	ZONE

REV	DATE	ALTERED	CHECKED	APPROVED	ZONE
00	17/05/2017	ALTERED	CHECKED	APPROVED	ZONE

REV	DATE	ALTERED	CHECKED	APPROVED	ZONE
00	17/05/2017	ALTERED	CHECKED	APPROVED	ZONE

REV	DATE	ALTERED	CHECKED	APPROVED	ZONE
00	17/05/2017	ALTERED	CHECKED	APPROVED	ZONE

REV	DATE	ALTERED	CHECKED	APPROVED	ZONE
00	17/05/2017	ALTERED	CHECKED	APPROVED	ZONE

REV	DATE	ALTERED	CHECKED	APPROVED	ZONE
00	17/05/2017	ALTERED	CHECKED	APPROVED	ZONE

REV	DATE	ALTERED	CHECKED	APPROVED	ZONE
00	17/05/2017	ALTERED	CHECKED	APPROVED	ZONE

REV	DATE	ALTERED	CHECKED	APPROVED	ZONE
00	17/05/2017	ALTERED	CHECKED	APPROVED	ZONE

REV	DATE	ALTERED	CHECKED	APPROVED	ZONE
00	17/05/2017	ALTERED	CHECKED	APPROVED	ZONE

REV	DATE	ALTERED	CHECKED	APPROVED	ZONE
00	17/05/2017	ALTERED	CHECKED	APPROVED	ZONE

REV	DATE	ALTERED	CHECKED	APPROVED	ZONE
00	17/05/2017	ALTERED	CHECKED	APPROVED	ZONE

REV	DATE	ALTERED	CHECKED	APPROVED	ZONE
00	17/05/2017	ALTERED	CHECKED	APPROVED	ZONE

REV	DATE	ALTERED	CHECKED	APPROVED	ZONE
00	17/05/2017	ALTERED	CHECKED	APPROVED	ZONE

REV	DATE	ALTERED	CHECKED	APPROVED	ZONE
00	17/05/2017	ALTERED	CHECKED	APPROVED	ZONE

Sl. No.	REQUIREMENT	Bidder's Response																				
1	Bidders should be the MANUFACTURER of 'RIP Bushings of 145 KV, 245 KV & above class.'	<input type="checkbox"/> YES																				
	Bidders to provide Self Undertaking on their Letter Head that Bidder is capable of executing the contract/order under captioned enquiry.	<input type="checkbox"/> Submitted																				
2	<b>EXPERIENCE:-</b> Bidders should have experience of manufacturing and supply of atleast 1 No. "RIP Bushings of 145 KV, 245 KV & above class. for transformer application during last 3 year as on date of technical bid opening to any customer listed below:	<input type="checkbox"/> YES																				
	1. PSU- State/ Central Govt.	<input type="checkbox"/> <b>Pl tick/ as applicable</b>																				
	2. Government - State/ Central	<input type="checkbox"/>																				
	3. Transformer manufacturer / Power Utility Company / Public Listed Company	<input type="checkbox"/>																				
	The bidder shall submit copy of PO and Tax Invoice of minimum one order executed in the last three years and provide the details as per the table below:	<input type="checkbox"/> Submitted																				
	<table border="1"> <thead> <tr> <th>Customer Name, Address &amp; Contact No.</th> <th>Order No. &amp; Date</th> <th>Qty. supplied</th> <th>Tax Invoice No. / Date</th> <th>Remark, if any</th> </tr> </thead> <tbody> <tr> <td></td> <td></td> <td></td> <td></td> <td></td> </tr> <tr> <td></td> <td></td> <td></td> <td></td> <td></td> </tr> <tr> <td></td> <td></td> <td></td> <td></td> <td></td> </tr> </tbody> </table>	Customer Name, Address & Contact No.	Order No. & Date	Qty. supplied	Tax Invoice No. / Date	Remark, if any																
Customer Name, Address & Contact No.	Order No. & Date	Qty. supplied	Tax Invoice No. / Date	Remark, if any																		
3	It is better / desired that New vendors who are not registered with BHEL, Jhansi should submit duly filled "Supplier Registration Form (SRF)" along with the requested documents. The SRF is available on line on our website www.bhel.com. However the same is not mandatory.	<input type="checkbox"/> Document Submitted																				

- Supporting documents for the details filled above have been submitted.
- We agree that our bid is liable to be rejected in case (a) the relevant information is not filled, (b) documentation required as above is incomplete, (c) there are false declarations, and (d) if we do not meet the PQR.
- Criteria at Sl. No. 3 is desirable. Other are mandatory.

(Signature of the Supplier with Name, Designation & Seal)