

BHARAT HEAVY ELECTRICALS LTD., BHOPAL
MATERIAL MANAGEMENT (EM)
PIPLANI – BHOPAL – 462 022 (M.P)
PHONE : + 91 755 250 3031 / 5052
e-mail:- kumarhemant@bhel.in, akumar1@bhel.in

OPEN TENDER NOTICE No. : MEX/26-27/E1563043

Tenders in two part bid system are invited for rate contract of the following items. Complete tender document can be downloaded from BHEL website <http://www.bhel.com> & BHEL e-procurement website <https://eprocurebhel.co.in/nicgep/app>. *The tender should be submitted before 03.00 PM of 08/07/2026 through* BHEL e-procurement website <https://eprocurebhel.co.in/nicgep/app>.

Note :- All enclosures are available on BHEL website <http://www.bhel.com> as well as BHEL e-procurement website <https://eprocurebhel.co.in/nicgep/app> against the above enquiry.

S. No	Enquiry no.	NIC Tender ID	Item	Qty.	Due date
1	E1563043	2026_BHEL_62433_1	FINISHED THRUST BUSH	50 Nos. (+/- 20 %)	08/07/2026
2			FINISHED GUIDE BUSH	15 Nos. (+/- 20 %)	
3			FINISHED GUIDE BUSH	45 Nos. (+/- 20 %)	

Note:- All subsequent corrigendum/amendment shall be published only on BHEL e-procurement website <https://eprocurebhel.co.in/nicgep/app> against the enquiry no. Hence, bidders are advised to be always in touch with above e-procurement website till the tender is finally opened.

Ajay Kumar
Sr. Engineer (MEX)
अजय कुमार / AJAY KUMAR
वरिष्ठ अभियंता / Sr. Engineer
सा. प्र. - ई. एम. / M.M. - E.M.
बी.एच.ई.एल., भोपाल / B.H.E.L., BHOPAL

 ENQUIRY TWO PART BID BP_200101 E-TENDER	भारत हेवी इलेक्ट्रिकल्स लिमिटेड, पिपलानी, भोपाल- ४६२०२२ (भारत) सामग्री प्रबंधन विभाग BHARAT HEAVY ELECTRICALS LIMITED, PIPLANI, BHOPAL-462022 (INDIA) MATERIALS MANAGEMENT DIVISION		ENQUIRY NO E1563043 ENQUIRY DATE 17/06/26 ENQUIRY DUE DATE 08/07/26
	TIN NO- 23573000001 PHONE NO : 91-755-2500100	ECC NO- AAACB4146PXM009	MPCT NO- HEL/05/01/0001/S15/11/79 FAX : 91-755-2500023 www.bhel.com

ENQUIRY

SUPP NAME AND ADDRESS	SUPP CODE	REV CD	REV NO	REV DATE	NO OF CATY2	NO OF CATY3	ENQ NO OF ITEMS	INDENT NO
	0	1	0	NA	3	15	3	121760024
	GUARANTEE CERTIFICATE		Y	SUPPLY CONDITION		(1) IN PROPERLY PACKED CONDITION. (2) TR P TO BE APPLIED ON ALL M/CND SURFACES.		
	TEST CERTIFICATE		Y	TECHNICAL CONDITION		AS PER DRAWING & SPECN		
	INSTRUCTION BOOKLET		N	INSPECTION CONDITION		INSPECTION BY TPIA AT SUPPLIER WORKS AS PER QAP NO-QA/MT/BOI/040 & QA/MT/BOI/010.		
	SAMPLE		N					
	GATE PASS		Y					

NOTE: QUOTE PRICE BOTH IN FIGURES & WORDS. IN CASE OF MISMATCH PRICE IN WORDS WILL BE VALID, QUOTATIONS NOT BEARING ENQUIRY NO AND DUE DATE LIABLE TO BE REJECTED.

SL NO	MATERIAL CODE	DESC	UNIT	ITEM QTY	QTY VR%	LOT NO	LOT QTY	DEST	DELIVERY DATE
1	BP9503036852	FINISHED THRUST BUSH FOR THRUST AND GUIDE BEARING ASSY TO DRG. 24025442039, VAR.00, REV.00.	NO	50.000	20	1	10.000	217	30/10/26
						2	10.000	217	30/12/26
						3	10.000	217	25/02/27
						4	10.000	217	30/04/27
						5	10.000	217	30/06/27
2	BP9503036658	FINISHED GUIDE BUSH FOR GUIDE BEARING ASSY. TO DRG.NO.34028042043,ITEM-01.REV.05.	NO	15.000	20	1	3.000	217	30/10/26
						2	3.000	217	30/12/26
						3	3.000	217	25/02/27
						4	3.000	217	30/04/27
						5	3.000	217	30/06/27
3	BP9503036606	FINISHED GUIDE BUSH FOR GUIDE BEARING ASSY. TO DRG.NO. 34028042044,ITEM-01.REV.04.	NO	45.000	20	1	9.000	217	30/10/26
						2	9.000	217	30/12/26
						3	9.000	217	25/02/27
						4	9.000	217	30/04/27
						5	9.000	217	30/06/27

NOTE: BHEL, BHOPAL'S Standard Terms & Conditions BP200102C/BP205316 for imports and BP200102C/ BP205316 for indigenous procurements form a part of this Enquiry. Bidders may obtain from us copies of these terms and conditions if not already available.

Note: During Bid Evaluation, No loading of price with regard to preferential payment of within 45 days will be made on vendore falling under MSMED ACT - OCT 06

Please submit your lowest quotation in sealed envelop essentially superscribed with ENQUIRY NO, DUE DATE AND PARTY'S NAME so as to reach at TENDER ROOM, GROUND FLOOR, ADM BUILDING, BHEL, PIPLANI BHOPAL-462022 by 11.00 am of due date.

SPECIAL REMARK: Bid to be submitted through e-procurement. Refer eproc link on BHEL Bhopal B2B site.

- This is only a request for Quotation & not an order.
- Small Scale industries should indicate SSI Regn. No. in Quotation/invoice.
- In case you are not making an offer against this Enquiry, we request you to post a regret letter.
- Indian vendors to please indicate GSTIN on their quotation.

- Documents Enclosed
- Drawing.
 - Catalogue.
 - Purchase specification.
 - Quality Surveillance Plan.

NAME : SHRI AJAY KUMAR / **SHRI AJAY KUMAR**
 DESG : SR.ENGINEER / **Sr. Engineer**
 0755-2505052 / **M.M. - E.M.**
 akumar1@bhel.in / **भोपाल / SIGN & SEAL**

 ENQUIRY TWO PART BID BP_200101 E-TENDER	भारत हेवी इलेक्ट्रिकल्स लिमिटेड, पिपलानी, भोपाल- 462022 (भारत) सामग्री प्रबंधन विभाग BHARAT HEAVY ELECTRICALS LIMITED, PIPLANI, BHOPAL-462022 (INDIA) MATERIALS MANAGEMENT DIVISION		ENQUIRY NO E1563043 ENQUIRY DATE 17/06/26 ENQUIRY DUE DATE 08/07/26
	TIN NO- 23573000001 ECC NO- AAACB4146PXM009 MPCT NO- HEL/05/01/0001/S15/11/79 PHONE NO : 91-755-2500100 FAX : 91-755-2500023 www.bhel.com		

**E
N
Q
U
I
R
Y**

REMARK [1] THIS IS AN OPEN TENDER E-PROCUREMENT ENQUIRY & OFFER TO BE SUBMITTED THROUGH NIC PORTAL (HTTPS://EPROCUREBHEL.CO.IN/NICGEP/AP) ONLY. [2] BHEL STD T&C BP200102C, BP205315 AS AVAILABLE AT HTTPS://BPL.BHEL.COM ARE APPLICABLE. [3] ALL GST PROVISIONS ARE APPLICABLE. [4] LOCAL CONTENT DECLARATION & CONFLICT OF INTEREST AMONG BIDDERS / AGENT DECLARATION AS PER ATTACHED FORMAT TO BE SUBMITTED WITH OFFER. [5] PLEASE QUOTE FOR BHEL BHOPAL DOOR DELIVERY BASIS INCLUDING P&F, FREIGHT & INSURANCE CHARGES. [6] THIS IS A RATE CONTRACT ENQUIRY. RATE CONTRACT ANNEXURE-A APPLICABLE. [7] PRICE QUOTED ON NIC SHOULD BE EXCLUSIVE OF GST. [8] QTY. VARIATION +/- 20 % IS APPLICABLE. [9] REVERSE AUCTION WILL BE DONE AS PER LATEST RA GUIDELINES. [10] SPLITTING WILL BE DONE BETWEEN 02 VENDORS IN THE RATIO 60:40, IF OTHER SUPPLIER ACCEPTS L1 PRICE. [11] SUPPLIER TO SUBMIT DULY FILLED, SIGNED & SEALED COPY OF PQR, TECHNO-COMMERCIAL BID DOCUMENTS, INTEGRITY PACT AND SIGNED & SEALED COPY OF RC ANNEXURE-A, ALL DRAWINGS, QAP, ALONG WITH ALL SUPPORTING DOCUMENTS. [12] E-PBG APPLICABLE AS MENTIONED IN RC ANNEXURE-A. [13] MATERIAL TO BE SUPPLIED AS PER DRAWING & SPECN. & IN PROPERLY PACKED CONDITION. TRP TO BE APPLIED ON ALL M/CND SURFACES. [14] MSE & MII BENEFIT WILL BE APPLICABLE AS PER GUIDELINES. [15] AS PER MII CIRCULAR, ONLY CLASS I AND CLASS II LOCAL SUPPLIERS OFFERS SHALL BE CONSIDERED FOR FURTHER EVALUATION. [16] OFFERS OF VENDORS WHO OR WHOSE OEM IS ON OUR MISCC / UNIT / CORPORATE / CUSTOMER LEVEL HOLD OR BANNED/ DEBARRED, WILL NOT BE CONSIDERED FOR FURTHER EVALUATION.

DRAWING	Y	PURCH SPEC	Y	CATALOUGE	N	Quality Surveillance Plan	Y	TWO PART BID	Y

NOTE: BHEL, BHOPAL'S Standard Terms & Conditions BP200102C/BP205316 for imports and BP200102C/ BP205316 for indigenous procurements form a part of this Enquiry. Bidders may obtain from us copies of these terms and conditions if not already available.

Note: During Bid Evaluation, No loading of price with regard to preferential payment of within 45 days will be made on vendore falling under MSMED ACT - OCT 06

Please submit your lowest quotation in sealed envelop essentially superscribed with ENQUIRY NO, DUE DATE AND PARTY'S NAME so as to reach at TENDER ROOM, GROUND FLOOR, ADM BUILDING, BHEL, PIPLANI BHOPAL-462022 by 11.00 am of due date.	SPECIAL REMARK: Bid to be submitted through e-procurement. Refer eproc link on BHEL Bhopal B2B site.
1. This is only a request for Quotation & not an order. 2. Small Scale industries should indicate SSI Regn. No. in Quotation/invoice. 3. In case you are not making an offer against this Enquiry, we request you to post a regret letter. 4. Indian vendors to please indicate GSTIN on their quotation.	Documents Enclosed 1. Drawing. 3. Purchase specification. 2. Catalogue. 4. Quality Surveillance Plan.
	NAME : SHRI AJAY KUMAR DESG : SR. ENGINEER 0755-2505052 akumar1@bhel.in

 अजय कुमार / AJAY KUMAR
 सि. प्र. इं. एम. / Sr. Engineer
 सा. प्र. इं. एम. / M.M. E.M.
 बी. एच. ई. एल., भोपाल / B.H.E.L., BHOPAL

Techno-Commercial Bid
(To be filled by supplier and submit with offer)

Tender No.		E1563043		
Item Description :		IT. 01:- FINISHED THRUST BUSH FOR THRUST AND GUIDE BEARING ASSY TO DRG. 24025442039, VAR.00, REV.00. IT. 02 :-FINISHED GUIDE BUSH FOR GUIDE BEARING ASSY, TO DRG.NO.34028042043,ITEM-01,REV.05. IT. 03 :-FINISHED GUIDE BUSH FOR GUIDE BEARING ASSY, TO DRG.NO. 34028042044,ITEM-01,REV.04.		
Remarks :		[1] THIS IS AN OPEN TENDER E-PROCUREMENT ENQUIRY & OFFER TO BE SUBMITTED THROUGH NIC PORTAL (HTTPS://EPROCUREBHEL.CO.IN/NICGEP/AP) ONLY. [2] BHEL STD T&C BP200102C, BP205315 AS AVAILABLE AT HTTPS://BPL.BHEL.COM ARE APPLICABLE. [3] ALL GST PROVISIONS ARE APPLICABLE. [4] LOCAL CONTENT DECLARATION & CONFLICT OF INTEREST AMONG BIDDERS / AGENT DECLARATION AS PER ATTACHED FORMAT TO BE SUBMITTED WITH OFFER. [5] PLEASE QUOTE FOR BHEL BHOPAL DOOR DELIVERY BASIS INCLUDING P&F, FREIGHT & INSURANCE CHARGES. [6] THIS IS A RATE CONTRACT ENQUIRY. RATE CONTRACT ANNEXURE-A APPLICABLE. [7] PRICE QUOTED ON NIC SHOULD BE EXCLUSIVE OF GST. [8] QTY. VARIATION +/- 20 % IS APPLICABLE. [9] REVERSE AUCTION WILL BE DONE AS PER LATEST RA GUIDELINES. [10] SPLITTING WILL BE DONE BETWEEN 02 VENDORS IN THE RATIO 60:40, IF OTHER SUPPLIER ACCEPTS L1 PRICE. [11] SUPPLIER TO SUBMIT DULY FILLED, SIGNED & SEALED COPY OF PQR, TECHNOCOMMERCIAL BID DOCUMENTS, INTEGRITY PACT AND SIGNED & SEALED COPY OF RC ANNEXURE-A, ALL DRAWINGS, QAP, ALONG WITH ALL SUPPORTING DOCUMENTS. [12] E-PBG APPLICABLE AS MENTIONED IN RC ANNEXURE-A. [13] MATERIAL TO BE SUPPLIED AS PER DRAWING & SPECN. & IN PROPERLY PACKED CONDITION. TRP TO BE APPLIED ON ALL M/CND SURFACES. [14] MSE & MII BENEFIT WILL BE APPLICABLE AS PER GUIDELINES. [15] AS PER MII CIRCULAR, ONLY CLASS I AND CLASS II LOCAL SUPPLIERS OFFERS SHALL BE CONSIDERED FOR FURTHER EVALUATION. [16] OFFERS OF VENDORS WHO OR WHOSE OEM IS ON OUR MISCC / UNIT / CORPORATE / CUSTOMER LEVEL HOLD OR BANNED/ DEBARRED, WILL NOT BE CONSIDERED FOR FURTHER EVALUATION.		
Sr. No.	ELEMENTS	Standards	To be offered / confirmed by supplier	Remarks, if any
1	Quotation Reference & date	As per supplier		
2	HSN / SAC code	As per supplier		
2.1	GST TYPE & ITS PERCENTAGE APPLICABLE Item wise mentioned in the offer (IGST/CGST+SGST/UGST)	As per supplier		
3	Quotation Currency	In INR		
4	E-Mail	As per supplier		
5	Phone/Mobile	As per supplier		
6	Contact Person	As per supplier		
7	Order to be placed on	As per supplier		
8	Address	As per supplier		
9	Minimum delivery period to be quoted in no of days from the date of Purchase Order.	Our requirement of material is :- 1st Lot within 90 days from PO date for maximum 10 nos. qty. and subsequent lots shall be within 60 days from previous lot for maximum 10 nos. qty. for each items		
10	Prices shall be Firm.	Yes		
11	INSPECTION: As given in enquiry.	Yes		
12	<u>Delivery Destination</u> : - The material is required to be supplied to FOR BHEL Bhopal with all freight charges on paid basis.	Yes		
12.1	Price to be furnished on FOR destination BHEL Bhopal, duly insured basis inclusive of P&F charges.	Yes		
13	Quoted for all the items of tender enquiry	Yes / No. (If "No" please mention item number of regretted items)		
14	Technical Specifications	Accepted as per enquiry / Accepted with deviation (If select Accepted with deviation, please mention the deviation)		
15	Guarantee Period of Material as per clause no. 18 of enquiry GTC BP200102C.	Yes		
16	TC , GC and ALL Inspection report as per tender enquiry and specification will be submitted along with each consignment.	Yes (In case of "No" your offer may be rejected).		
17	Brand Name, If any.	As per supplier		
18	Supply from	As per supplier		
19	Quotation Validity will be 90 days from the date of Technical bid opening.	Yes		
20	Are you registered under MSE ACT 2006 as small or micro.	Yes / No (If select Yes, please enclosed latest printed UDYAM certificate)		

Name of Supplier:
Sign and Seal of Supplier

Techno-Commercial Bid (To be filled by supplier and submit with offer)				
Tender No.		E1563043		
Description :		IT. 01:- FINISHED THRUST BUSH FOR THRUST AND GUIDE BEARING ASSY TO DRG. 24025442039, VAR.00, REV.00. IT. 02 :-FINISHED GUIDE BUSH FOR GUIDE BEARING ASSY. TO DRG.NO.34028042043,ITEM-01.REV.05. IT. 03 :-FINISHED GUIDE BUSH FOR GUIDE BEARING ASSY. TO DRG.NO. 34028042044,ITEM-01.REV.04.		
Sr. No.	ELEMENTS	Standards	To be offered/confirmed by supplier	Remarks, if any
21	<p>Payment terms: 100% payment in 90 days of receipt (45 days for Micro & Small and 60 days for Medium enterprises as registered in Udyam certificate as per relevant MSME act in force) and subject to acceptance of material and relevant documents at BHEL. Any deviation from the above payment terms, if accepted (by BHEL), shall be loaded @ "Repo Rate + 4%" for the purpose of bid evaluation.</p> <p>Important note: An MSE enterprises who are traders/agent/dealer shall not be benefitted under public procurement. Therefore, no benefit including terms of payment within 45 days shall be passed on to MSE vendor who are trader, dealer and agent. If you are not an "original manufacturer" of indented product against above enquiry, please accept the payment terms as "100% payment in 90 days after receipt & acceptance of material at BHEL". In case of non-acceptance or any deviation from the above payment terms, if accepted (by BHEL), shall be loaded @ "Repo Rate + 4%" for the purpose of bid evaluation.</p>	90 days / 60 days /45 Days (If supplier is MSE (Micro/small), please select 45 days and if supplier is in Medium category, please select 60 days and if supplier is non -MSE or Trader/Dealer/Agent, please select 90 days)		
22	Other Charges (If any)	Applicable / Not Applicable. (If applicable please mention percentage (%) / Value (along with type of charges).		
23	Transit Insurance will be in supplier scope	Yes		
24	Penalty: - Penalty for late delivery shall be 0.5% of the undelivered portion per week of delay or part thereof, subject to a maximum of 10% of the undelivered order value owing to delayed delivery. Total undelivered order value above shall be item wise, lot wise order value of PO.(Please refer clause 9 of GTC - BP200102C).	Yes / No (In case of "No", your offer will be loaded suitably)		
25	Acceptance of General Terms and Conditions of enquiry (Form No. BP- 200102C) & BHEL P.O. Terms & Conditions (Indigenous) BP205315 (available at B2B site of BHEL Bhopal).	Yes (In case of "No" your offer may be rejected).		
26	Kindly confirm whether other family firms or sister concern affiliates / subsidiary firms are participating in the same tender, so as to eliminate the possibility of cartel formation. (If yes kindly attach filled, sign & sealed copy of Annexure-IX).	Kindly attach 'Annexure -IX' with seal & sign.		
27	Confirm whether bidder is Manufacturer or Trader or Dealer or Agent of items under enquiry. In case of Trader or Dealer or Agent, please furnish authorization certificate from OEM.	As per supplier		
28	I/We hereby certify that the quoted items(s) offered by us in this enquiry is /are having local content (in %) of	As per supplier		
28.1	I/We hereby certify that the local content % certified above is in line with definition of local content given in Public Procurement (Preference to Make in India) Order 2017 Dtd. 19-07-2024 and I/We qualify as (Class- I/Class-II/Non-Local supplier - Fill in one which is applicable).	As per supplier [Class I - Equal to or more than 50%, Class II - More than 20% but less than 50%, Non - Local :Less than or equal to 20%] [NOTE: Please provide Certification regarding local content on your letter head for the quoted items with seal & sign.]		
28.2	Address of location at which the local value addition is made:	As per supplier		
28.3	By filling "Yes" in adjacent Box, I hereby declare & confirm that the details furnished above are true and correct to the best of my knowledge and belief and I undertake to inform you of any changes therein immediately. In case any of the above information is found to be false or untrue or misleading or misrepresenting, I am aware that I may be held liable for it.	Yes / No		

1) Deviation in any commercial condition shall be suitably loaded in the offered price.

2) In case of any conflict, confirmation by vendor provided here will supersede.

3) In case bidder is not making an offer against this enquiry, we request the bidder to post the regret letter

Name of Supplier:.....

Seal & Sign of supplier

ENQUIRY NO. E1563043, DATED 17/06/2026**TERMS AND CONDITIONS FOR RATE CONTRACT FOR THRUST BUSH & GUIDE BUSH**

1. **Duration of Contract:** Rate contract shall be valid for a period of 01 years for ordering from the date of RC agreement date. Rate contract shall be extendable for further periods as per mutual consent.
2. **Delivery:** 1st Lot within 90 days from PO date for maximum 10 nos. qty. and subsequent lots shall be within 60 days from previous lots for maximum 10 nos. qty. for each items. Drawing wise as per BHEL requirement PO will be placed during the RC period. **Please offer your best possible delivery against our requirement.**
3. All technical requirements should be as per drawing & specification with latest revisions and all dimensions & tolerances should be maintained as per PO requirements.
4. Quantity variation \pm 20% is applicable.
5. PQR applicable. Offers of vendors, who meet PQR clause will only be accepted & considered for further evaluation.
6. RC quantity for each item may be distributed between 02 vendors in the ratio of 60:40 at L1 rate, if other suppliers accept L1 price. If no other supplier accepts L1 rate then total RC qty. of that item may be given to L1 supplier.
7. **Packing & identification:** Material to be supplied in Properly packed condition. PO No., PO item No., Lot/Batch No., Drawing No., Supplier's Name is mandatory to be punched / mentioned on each job.
8. **Unit rate for all the items should be quoted separately in "Rs. per No."**. Rate should be on F.O.R. Destination door delivery basis including transportation, transit insurance, packing & forwarding charges. The GST shall be payable extra. Applicable rates and HSN code are to be mentioned in your offer.
9. **Quoted unit rate will be firm during entire contractual period and PVC will not be applicable. Offers of bidders with PVC will be rejected.**
10. **Test & Guarantee Certificate:** Complete Set of TPIA Inspection Report along with Test and guarantee certificates shall be submitted for each supply. **In absence of TPIA report, TC & GC, material is liable for rejection.**
11. **Order will be placed as per actual order book position of BHEL. Rate contract agreement does not guarantee PO commitment to vendor.**
12. Inspection shall be done by BHEL appointed Third Party Inspection Agency (TPIA) at supplier works as per BHEL QA Plan No. QA/MT/BOI/040, Rev-00 for Thrust Bush & QA/MT/BOI/010, Rev-01 for Guide Bush.
13. **Payment terms:** 100% payment in 90 days of receipt (45 days for Micro & Small (Manufacturer Supplier) and 60 days for Medium enterprises (Manufacturer Supplier) as registered in Udyam certificate as per relevant MSME act in force) and subject to acceptance of material and relevant documents at BHEL. Vendor has to submit latest printed UDYAM certificate for availing benefits under MSE.
14. Electronic Performance Bank Guarantee (e-PBG) (as per BHEL Format) of 5% of total value of Rate contract, will be submitted within 30 days of Rate contract date with validity of 02 months beyond Guarantee period i.e. 14 months (12 month + 02 month) from the date of Final acceptance of Goods . E-PBG is applicable only if Rate contract value for individual supplier will be 2 crore or above.
In case of delay in submission of performance security, enhanced performance security which would include interest "Repo Rate + 4%" for the delayed period, shall be submitted by the bidder. Further, if performance security is not submitted till such time the first bill becomes due, the amount of performance security due shall be recovered as per terms defined in NIT / contract, from the bills along with due interest.

15. The offer shall be in two parts viz-
Part I - Technical & Commercial Offer
Part II - Price Offer Only

Both Part - I and Part - II bids should be uploaded on our e-procurement web page before 15.00 Hrs. of due date.

16. **Basis for deciding lowest (L1) offer:**
i. Only offers meeting the terms and conditions of the enquiry will be considered.
ii. All the offers shall be compared for total cost to BHEL at BHEL stores.
iii. *Offers having deviations to the terms and conditions will be suitably loaded or are liable to be rejected.*
17. **Validity of Offer:** Quotation should be valid for a period of **minimum 90 days** from the date of opening of tender.
18. **Penalty for Late Delivery:** Penalty for late delivery shall be 0.5% of the undelivered portion per week of delay or part thereof, subject to a maximum of 10% of the undelivered order value owing to delayed delivery. Total undelivered order value above shall be item wise, lot wise order value of PO.
19. The purchase orders against the Rate Contract will be issued from time to time as per vendor quoted & accepted delivery OR as mutually agreed at the time of issue of PO as per BHEL requirement. The vendors should ensure timely dispatch as per the delivery schedule indicated in the purchase order.
20. BHEL reserves the right to cancel:
i. It's requirement of part or full quantity at any stage of the tender finalization or even after finalization of tender.
ii. The order(s) if any suppliers(s) found to be "unsatisfactory" during our periodical assessment processes / review of assessment process / non-compliance of statutory requirements etc. as required for "vendor registration" during the execution of order(s).
21. Apart from the above, General Terms & Conditions Of Enquiry (BP200102C) & BHEL, P.O. Terms & Conditions (Indigenous) BP205315 respectively / latest revision available at the vendor portal, will also be applicable.
22. **Acceptance of all the above terms & conditions along with General Terms & Conditions Of Enquiry (BP200102C) & BHEL, P.O. Terms & Conditions (Indigenous) BP205315 are required in your offer. The same is to be signed and sealed by all the vendors & uploaded on our EPS along with Part-1 offer.**

(To be signed & affix by vendors
in acceptance of all above points)

INTEGRITY PACT**Between**

Bharat Heavy Electricals Ltd. (BHEL), a company registered under the Companies Act 1956 and having its registered office at "BHEL House", Siri Fort, New Delhi - 110049 (India) hereinafter referred to as "The Principal", which expression unless repugnant to the context or meaning hereof shall include its successors or assigns of the ONE PART

and

_____ (description of the party along with address), hereinafter referred to as "The Bidder/ Contractor" which expression unless repugnant to the context or meaning hereof shall include its successors or assigns of the OTHER PART

Preamble

The Principal intends to award, under laid-down organizational procedures, contract/s for E1563043,
FINISHED THRUST BUSH & GUIDE BUSH

_____ (hereinafter referred to as "Contract"). The Principal values full compliance with all relevant laws of the land, rules and regulations, and the principles of economic use of resources, and of fairness and transparency in its relations with its Bidder(s)/ Contractor(s).

In order to achieve these goals, the Principal will appoint panel of Independent External Monitor(s) (IEMs), who will monitor the tender process and the execution of the contract for compliance with the principles mentioned above.

Section 1- Commitments of the Principal

- 1.1 The Principal commits itself to take all measures necessary to prevent corruption and to observe the following principles: -
 - 1.1.1 No employee of the Principal, personally or through family members, will in connection with the tender for, or the execution of a contract, demand, take a promise for or accept, for self or third person, any material or immaterial benefit which the person is not legally entitled to.
 - 1.1.2 The Principal will, during the tender process treat all Bidder(s) with equity and reason. The Principal will in particular, before and during the tender process, provide to all Bidder(s) the same information and will not provide to any Bidder(s) confidential/ additional information through which the Bidder(s) could obtain an advantage in relation to the tender process or the contract execution.
 - 1.1.3 The Principal will exclude from the process all known prejudiced persons.
- 1.2 If the Principal obtains information on the conduct of any of its employees which is a penal offence under the Bharatiya Nyaya Sanhita (BNS) 2023 and Prevention of Corruption Act 1988 or any other statutory penal enactment, or if there be a substantive suspicion in this regard, the Principal will inform its Vigilance Office and in addition can initiate disciplinary actions.

Section 2 - Commitments of the Bidder(s)/ Contractor(s)

- 2.1 The Bidder(s)/ Contractor(s) commit himself to take all measures necessary to prevent corruption. The Bidder(s)/ Contractor(s) commits himself to observe the following principles during participation in the tender process and during the contract execution.



हेमन्त कुमार / HEMANT KUMAR

प्रबंधक / Manager

एम. ई. एक्स / M. E. X

वी.एच.ई.एल., भोपाल / B.H.E.L., BHOPAL

- 2.1.1 The Bidder(s)/ Contractor(s) will not, directly or through any other person or firm, offer, promise or give to the Principal or to any of the Principal's employees involved in the tender process or the execution of the contract or to any third person any material, immaterial or any other benefit which he/ she is not legally entitled to, in order to obtain in exchange any advantage of any kind whatsoever during the tender process or during the execution of the contract.
- 2.1.2 The Bidder(s)/ Contractor(s) will not enter with other Bidder(s) into any illegal or undisclosed agreement or understanding, whether formal or informal. This applies in particular to prices, specifications, certifications, subsidiary contracts, submission or non-submission of bids or any other actions to restrict competitiveness or to introduce cartelization in the bidding process.
- 2.1.3 The Bidder(s)/ Contractor(s) will not commit any penal offence under the relevant Bharatiya Nyaya Sanhita (BNS) and Prevention of Corruption Act; further the Bidder(s)/ Contractor(s) will not use improperly, for purposes of competition or personal gain, or pass on to others, any information or document provided by the Principal as part of the business relationship, regarding plans, technical proposals and business details, including information contained or transmitted electronically.
- 2.1.4 Foreign Bidder(s)/ Contractor(s) shall disclose the name and address of agents and representatives in India and Indian Bidder(s)/ Contractor(s) to disclose their foreign principals or associates. The Bidder(s)/ Contractor(s) will, when presenting his bid, disclose any and all payments he has made, and is committed to or intends to make to agents, brokers or any other intermediaries in connection with the award of the contract.
- 2.2 The Bidder(s)/ Contractor(s) will not instigate third persons to commit offences outlined above or be an accessory to such offences.
- 2.3 The Bidder(s)/ Contractor(s) shall not approach the Courts while representing the matters to IEMs and shall await their decision in the matter.

Section 3 - Disqualification from tender process and exclusion from future contracts

If the Bidder(s)/ Contractor(s), before award or during execution has committed a transgression through a violation of Section 2 above, or acts in any other manner such as to put his reliability or credibility in question, the Principal is entitled to disqualify the Bidder(s)/ Contractor(s) from the tender process, terminate the contract, if already awarded, exclude from future business dealings and/ or take action as per the separate "Guidelines on Banning of Business dealings with Suppliers/ Contractors", framed by the Principal.

Section 4 - Compensation for Damages

- 4.1 If the Principal has disqualified the Bidder (s) from the tender process before award / order acceptance according to Section 3, the Principal is entitled to demand and recover the damages equivalent to Earnest Money Deposit/ Bid Security.
- 4.2 If the Principal is entitled to terminate the Contract according to Section 3, or terminates the Contract in application of Section 3 above, the Bidder(s)/ Contractor (s) transgression through a violation of Section 2 above shall be construed breach of contract and the Principal shall be entitled to demand and recover from the Contractor an amount equal to 5% of the contract value or the amount equivalent to Security Deposit/ Performance Bank Guarantee, whichever is higher, as damages, in addition to and without prejudice to its right to demand and recover compensation for any other loss or damages specified elsewhere in the contract.

Section 5 - Previous Transgression

 कुमार / HEMANT KUMAR
 प्रबंधक / Manager
 एम. ई. एक्स / M. E. X
 सी.एस.ई.एल. भोपाल / B.H.E.L. BHOPAL

- 5.1 The Bidder declares that no previous transgressions occurred in the last 3 (three) years (to be reckoned from date of bid submission) with any other company in any country conforming to the anti-corruption approach in India that could justify his exclusion from the tender process. The date of such transgression, for the purpose of disclosure by the bidders in this regard, would be the date on which cognizance of the said transgression was taken by the competent authority. The transgression(s), for which cognizance was taken even before the said period of three years, but are pending conclusion, shall also be reported by the bidders.
- 5.2 If the Bidder makes incorrect statement on this subject, he can be disqualified from the tender process or the contract, if already awarded, can be terminated for such reason or action can be taken as per the separate "Guidelines on Banning of Business dealings with Suppliers/ Contractors", framed by the Principal.

Section 6 - Equal treatment of all Bidder (s)/ Contractor (s) / Sub-contractor (s)

- 6.1 The Principal will enter into Integrity Pacts with identical conditions as this Integrity Pact with all Bidders and Contractors.
- 6.2 In case of a joint venture, all the partners of the joint venture should sign the Integrity Pact. In case of Sub-contracting, the Principal Contractor shall be solely responsible for the adherence to the provisions of IP by the sub-contractor(s).
- 6.3 The Principal will disqualify from the tender process all Bidders who do not sign this Integrity Pact or violate its provisions.

Section 7 - Criminal Charges against violating Bidders/ Contractors /Subcontractors

If the Principal obtains knowledge of conduct of a Bidder, Contractor or Subcontractor, or of an employee or a representative or an associate of a Bidder, Contractor or Subcontractor which constitutes corruption, or if the Principal has substantive suspicion in this regard, the Principal will inform the Vigilance Office.

Section 8 -Independent External Monitor(s)

- 8.1 The Principal appoints competent and credible panel of Independent External Monitor (s) (IEMs) for this Integrity Pact. The task of the IEMs is to review independently and objectively, whether and to what extent the parties comply with the obligations under this Integrity Pact on receipt of any complaint by them from the bidder(s).
- 8.2 The IEMs are not subject to instructions by the representatives of the parties and performs his functions neutrally and independently. He reports to the CMD, BHEL.
- 8.3 The IEMs shall be provided access to all documents/ records pertaining to the Contract, for which a complaint or issue is raised before them as and when warranted. However, the documents/records/information having National Security implications and those documents which have been classified as /Top Secret are not to be disclosed.
- 8.4 The Principal will provide to the IEMs sufficient information about all meetings among the parties related to the Contract provided such meetings could have an impact on the contractual relations between the Principal and the Contractor. The parties offer to the IEMs the option to participate in such meetings.
- 8.5 The role of IEM is advisory and the advice of IEM is non-binding on the Organization. However, as IEMs are invariably persons with rich experience who have retired as senior functionaries of the government, their advice would help in proper implementation of the IP.

- 8.6 For ensuring the desired transparency and objectivity in dealing with the complaints arising out of the tendering process, the matter should be examined by the full panel of IEMs jointly, who would look into the records, conduct an examination, and submit their joint recommendations to the Management. In case the full panel is not available due to some unavoidable reasons, the available IEM(s) will conduct examination of the complaints. Consent of the IEM(s), who may not be available, shall be taken on record.
- 8.7 The IEMs shall examine all the representations/grievances/ complaints received by them from the bidders or their authorized representative related to any discrimination on account of lack of fair play in modes of procurement and bidding systems, tendering method, eligibility conditions, bid evaluation criteria, commercial terms & conditions, choice of technology/ specifications etc.
- 8.8 The CMD, BHEL shall decide the compensation to be paid to the IEMs and its terms and conditions.
- 8.9 IEMs should examine the process integrity, they are not expected to concern themselves with fixing of responsibility of officers. Complaints alleging mala fide on the part of any officer of the Principal should be looked into by the CVO of the Principal.
- 8.10 If the IEMs have reported to the CMD, BHEL, a substantiated suspicion of an offence under relevant Bharatiya Nyaya Sanhita (BNS)/ Prevention of Corruption Act, and the CMD, BHEL has not, within reasonable time, taken visible action to proceed against such offence or reported it to the Vigilance Office, the IEMs may also transmit this information directly to the Central Vigilance Commissioner, Government of India.
- 8.11 After award of work, the IEMs shall look into any issue relating to execution of Contract, if specifically raised before them. As an illustrative example, if a Contractor who has been awarded the Contract, during the execution of Contract, raises issue of delayed payment etc. before the IEMs, the same shall be examined by the panel of IEMs.
- 8.12 However, the IEMs may suggest systemic improvements to the management of the Principal, if considered necessary, to bring about transparency, equity and fairness in the system of procurement.
- 8.13 The word 'Monitor' would include both singular and plural.

Section 9 - Pact Duration

- 9.1 This Integrity Pact shall be operative from the date this Integrity Pact is signed by both the parties. Any violation of the same would entail disqualification of the bidders and exclusion from future business dealings.
- 9.2 If any claim is made/ lodged during currency of this Integrity Pact, the same shall be binding and continue to be valid despite the lapse of this Pact as specified above, unless it is discharged/ determined by the CMD, BHEL.

Section 10 - Other Provisions

- 10.1 This Integrity Pact is subject to Indian Laws and exclusive jurisdiction shall be of the competent Courts as indicated in the Tender or Contract, as the case may be.
- 10.2 Changes and supplements as well as termination notices need to be made in writing.

- 10.3 If the Bidder(s)/ Contractor(s) is a partnership or a consortium or a joint venture, this Integrity Pact shall be signed by all partners of the partnership or joint venture or all consortium members.
- 10.4 Should one or several provisions of this Integrity Pact turn out to be invalid, the remainder of this Integrity Pact remains valid. In this case, the parties will strive to come to an agreement to their original intentions.
- 10.5 Only those bidders / contractors who have entered into this Integrity Pact with the Principal would be competent to participate in the bidding. In other words, entering into this Integrity Pact would be a preliminary qualification.
- 10.6 In the event of any dispute between the Principal and Bidder(s)/ Contractor(s) relating to the Contract, in case, both the parties are agreeable, they may try to settle dispute through Mediation before the panel of IEMs in a time bound manner. If required, the Principal may adopt any mediation rules for this purpose. However, not more than five meetings shall be held for a particular dispute resolution. The fees/expenses on dispute resolution shall be equally shared by both the parties. In case, the dispute remains unresolved even after mediation by the panel of IEMs, either party may take further action as the terms & conditions of the Contract.

16-6-26
हेमंत कुमार / HEMANT KUMAR
प्रबंधक / Manager
एम. ई. एक्स / M. E. X
बी.एच.ई.एल., भोपाल / B.H.E.L., BHOPAL

For & On behalf of the Principal
(Office Seal)

Place BHOPAL
Date 16-06-26

Witness: _____
(Name & Address)  16-06-26

अजय कुमार / AJAY KUMAR
वरिष्ठ अभियंता / Sr. Engineer
सा. प्र. - ई. एम. / M. M. - E. M.
बी.एच.ई.एल., भोपाल / B.H.E.L., BHOPAL

For & On behalf of the Bidder/ Contractor
(Office Seal)

Witness: _____
(Name & Address) _____

16-6-26
हेमंत कुमार / HEMANT KUMAR
प्रबंधक / Manager
एम. ई. एक्स / M. E. X
बी.एच.ई.एल., भोपाल / B.H.E.L., BHOPAL

Clause on IP in the tender**Integrity Pact (IP)**

- (a) IP is a tool to ensure that activities and transactions between the Company and its Bidders/ Contractors are handled in a fair, transparent and corruption free manner. Following Independent External Monitors (IEMs) on the present panel have been appointed by BHEL with the approval of CVC to oversee implementation of IP in BHEL.

SI	IEM	Email
1.	Dr. Sarat Kumar Acharya, Ex-CMD, NLC	iem1@bhel.in
2.	Shri R. Mukundan, IRPS (Retd.)	iem2@bhel.in
3.	Shri Madan Lal Meena, IAS (Retd.)	iem3@bhel.in

- (b) The IP as enclosed with the tender is to be submitted (duly signed by authorized signatory) along with techno-commercial bid (Part-I, in case of two/ three part bid). Only those bidders who have entered into such an IP with BHEL would be competent to participate in the bidding. In other words, entering into this Pact would be a preliminary qualification.
- (c) Please refer Section-8 of IP for Role and Responsibilities of IEMs. In case of any complaint arising out of the tendering process, the matter may be referred to the panel of IEMs. All correspondence with the IEMs shall be done through email only.

Note:

No routine correspondence shall be addressed to the IEM (phone/ post/ email) regarding the clarifications, time extensions or any other administrative queries, etc on the tender issued. All such clarification/ issues shall be addressed directly to the tender issuing (procurement) department's officials whose contact details are provided below:

Details of contact person(s):

(1) **हेमंत कुमार / HEMANT KUMAR**
 Name: **प्रबंधक / Manager**
 Deptt: **एच.ई.एक्स / M. E. X**
 Address: **श्री एच.ई.एल., भोपाल / B.H.E.L., BHOPAL**
 Phone: (Landline/ Mobile)
07552503031 / 9406906056
 Email: **kumarhemant@bhel.in**
 Fax: _____

(2) **अजय कुमार / AJAY KUMAR**
 Name: **वरिष्ठ अभियंता / Sr. Engineer**
 Deptt: **सा.प्र.-ई.एम. / M.M.- E.M.**
 Address: **श्री एच.ई.एल., भोपाल / B.H.E.L., BHOPAL**
 Phone: (Landline/ Mobile)
07552505052 / 9630230860
 Email: **ajkumar@bhel.in**
 Fax: _____

Minimum Technical Qualification Requirements for supply of Thrust Bush/Thrust Collar (Finish Machined) and Guide Bush (Finish Machined) as per BHEL Drawings

Ref.: AME/PQR/2025-26/11

Date : 20.03.2026

Sl. NO	Description of Qualification Requirements	Vendor response	
		Compl-plied	Bidders to submit following documents for compliance
1	The design features, dimensions, geometric tolerances, technical requirements, material of construction shall be strictly as per BHEL Drawing for Thrust Bush (Finish Machined) and Guide Bush (Finish Machined).	YES / NO	Compliance to be provided by vendor in the form of YES or NO.
2	<p>Vendor must have experience in supplying Thrust Bush / Thrust Collar / Guide bush / Thrust Flanges / Hollow Shafts / Coupling Hubs.</p> <p>Vendor must have successfully executed supplies for at least 03 Nos. of any of the above-mentioned items. Supply of only finish machined components will be acceptable.</p> <p>Out of these supplies, at least 01 (one) supply must have been made in the past 5 years, as calculated from Tender Opening Date (TOD).</p> <p>Also, at least one item must have been supplied with Outer Diameter equal to or more than the Bush Outer Diameter (for Guide bearing seating) as per current Enquiry item requirements.</p>	YES / NO	<p>Vendor has to furnish PO Copy and Proof of Supply (like Completion Certificate / Invoice copy / Third party inspection report etc.) to be provided.</p> <p>Test certificates (TC) of forgings for all the supplies must be submitted with offer. Test certificates shall cover Chemical composition, Mechanical properties, Dimensional report (3D CMM), Non-destructive test reports.</p> <p>NOTE :-</p> <p>If the vendor has supply experience fulfilling the aforementioned criteria, to BHEL Bhopal, then only the PO / SRV reference shall suffice against requirement of Supporting documents mentioned above. Supplies should have been completed as on TOD.</p>
3	a. Vendor must have manufacturing facility for Thrust Collar, Guide bush and their components, to manufacture Thrust Bush / Thrust Collar (Finish Machined) and Guide Bush (Finish Machined) as per BHEL Drawing.	YES / NO	a. Compliance to be provided by vendor in the form of YES or NO, and details of in-house manufacturing facilities to be submitted.
	b. If the forgings for Thrust Collar and/or Guide Bush are being sourced from outside, vendor has to provide details of their supplier(s) with their manufacturing facility.	YES / NO	b. Compliance to be provided by vendor in the form of YES or NO. If yes, details of forging supplier along with the Purchase order placed for same to be submitted.
4	<p>Vendor must confirm to comply all the clauses of following BHEL QA Plans :-</p> <p>i. QA/MT/BOI/040 (revision as per Enquiry) for Thrust Bush (Finish Machined).</p> <p>ii. QA/MT/BOI/010 (revision as per Enquiry) for Guide Bush (Finish Machined).</p>	YES / NO	Compliance to be provided by vendor in the form of YES or NO.

(Seal and Sign of Authorized signatory of Supplier)

22

Panchbhai
20/03/2026
Nidhu

1

SI. NO	Description of Qualification Requirements	Vendor response	
		Com-plied	Bidders to submit following documents for compliance
5	a. The vendor should have testing facilities to conduct tests as per BHEL QA Plans and Technical specifications. Testing equipment should be calibrated by NABL accredited lab, with valid certificates.	YES / NO	a. Compliance to be provided by vendor in the form of YES or NO, and details of in-house testing facilities to be submitted. Testing shall be witnessed by BHEL or BHEL approved inspection agency as per applicable QA Plans.
	b. If any facility of particular testing is not available in-house, vendor to agree to test in government / international accreditation agency approved labs.	YES / NO	b. Compliance to be provided by vendor in the form of YES or NO, and vendor to submit details of Outsourced labs / firms if testing is being outsourced.

NOTE :-

1. Compliance to above Minimum Technical Qualification Requirements is mandatory. In the absence of compliance of above requirements, offer of vendor is liable to be rejected.
2. Since the nature of item is critical, **No relaxation** in PQR shall be provided for MSE Vendors or MII Start-ups.
3. Only Manufacturers are eligible. Traders / agents etc. will not be considered.

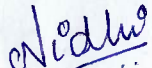
(Nidhi Gupta)
Sr. DGM / AME

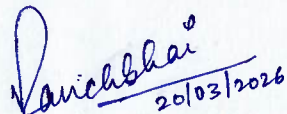
20/03/2026
(Vaibhav Panchbhai)
Manager / AME

(Seal and Sign of Authorized signatory of Supplier)

FIRST ANGLE PROJECTION

(ALL DIMENSIONS ARE IN mm)

24025442039
DRG. NO.

THE INFORMATION ON THIS DOCUMENT IS THE PROPERTY OF BHARAT HEAVY ELECTRICALS LIMITED. IT MUST NOT BE USED DIRECTLY OR INDIRECTLY IN ANY WAY DETRIMENTAL TO THE INTEREST OF THE COMPANY.

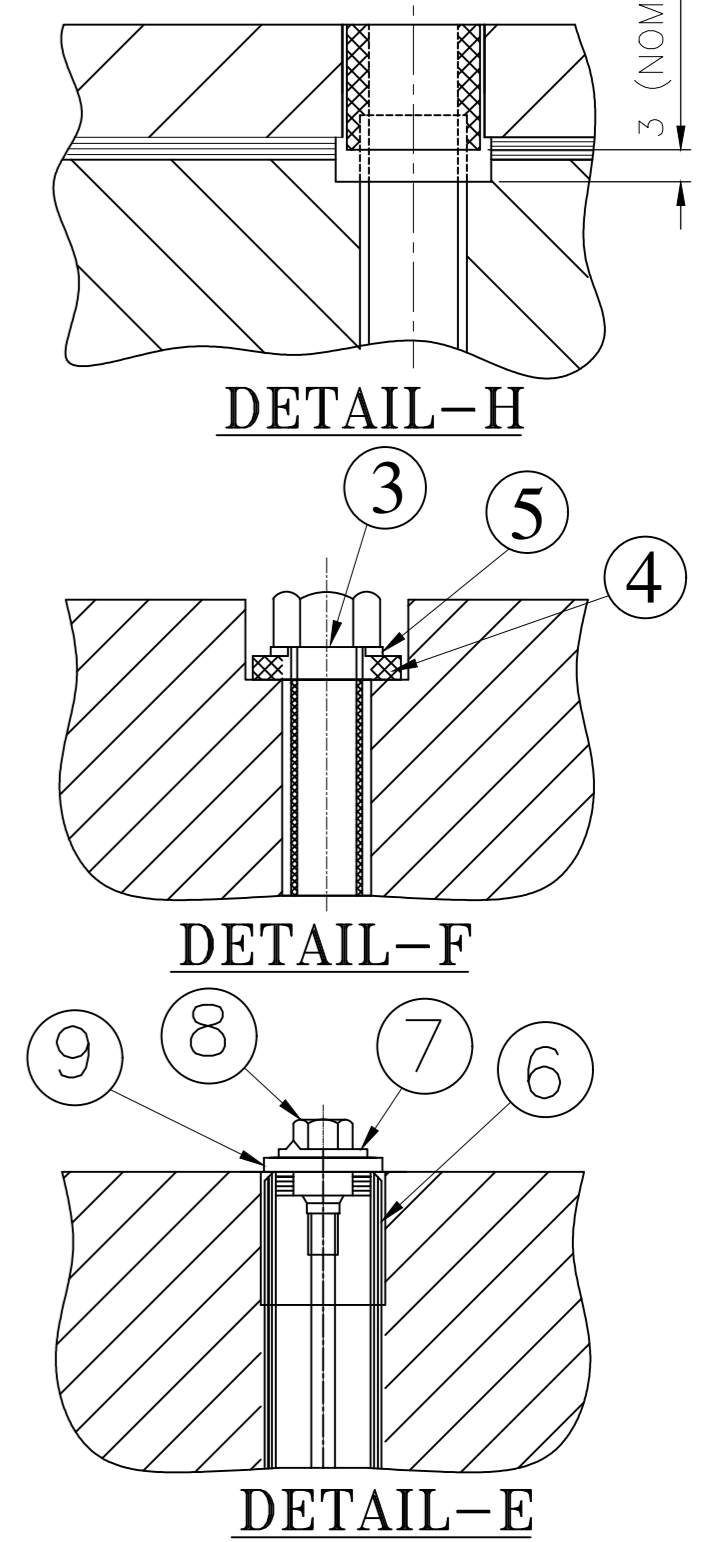
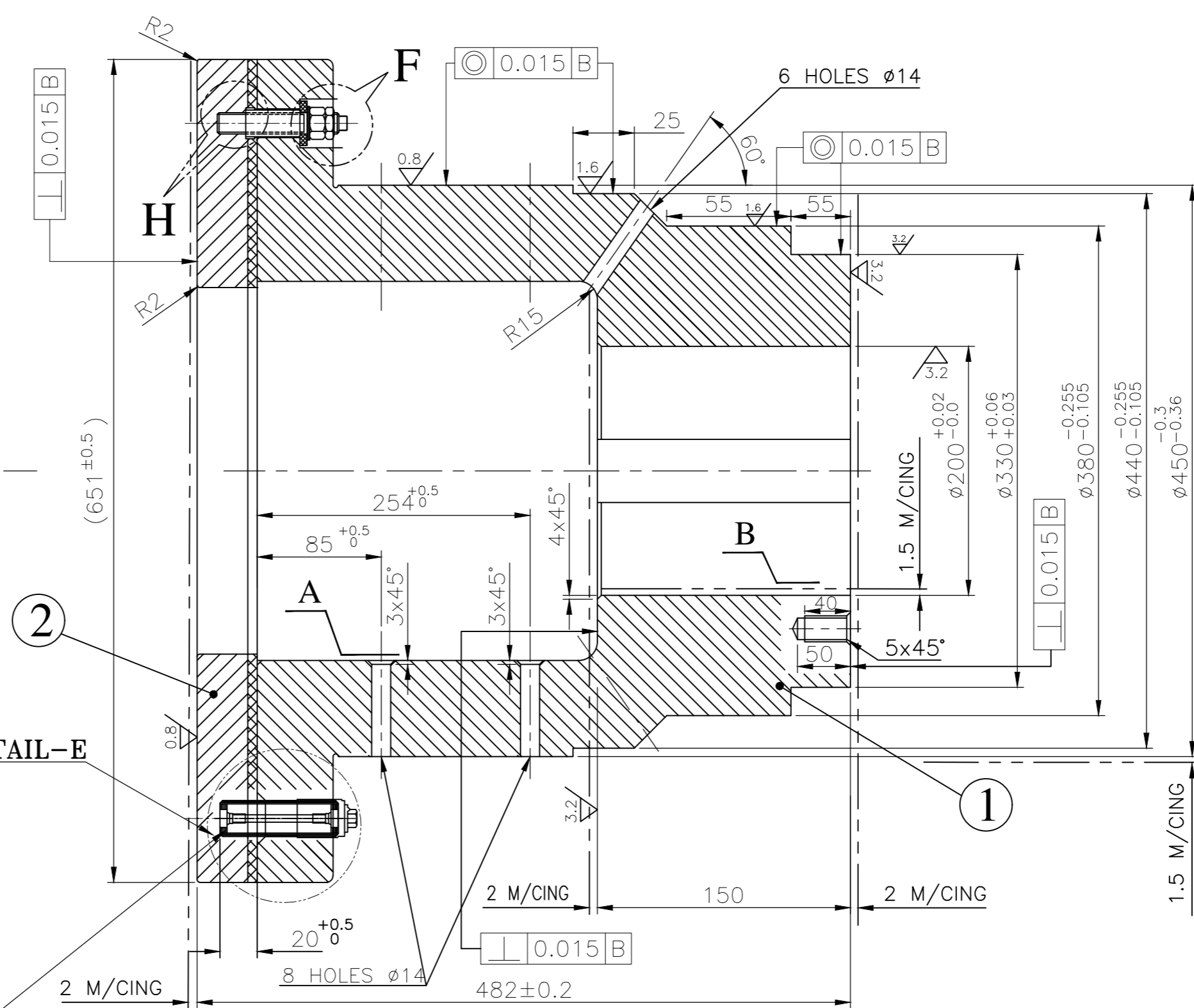
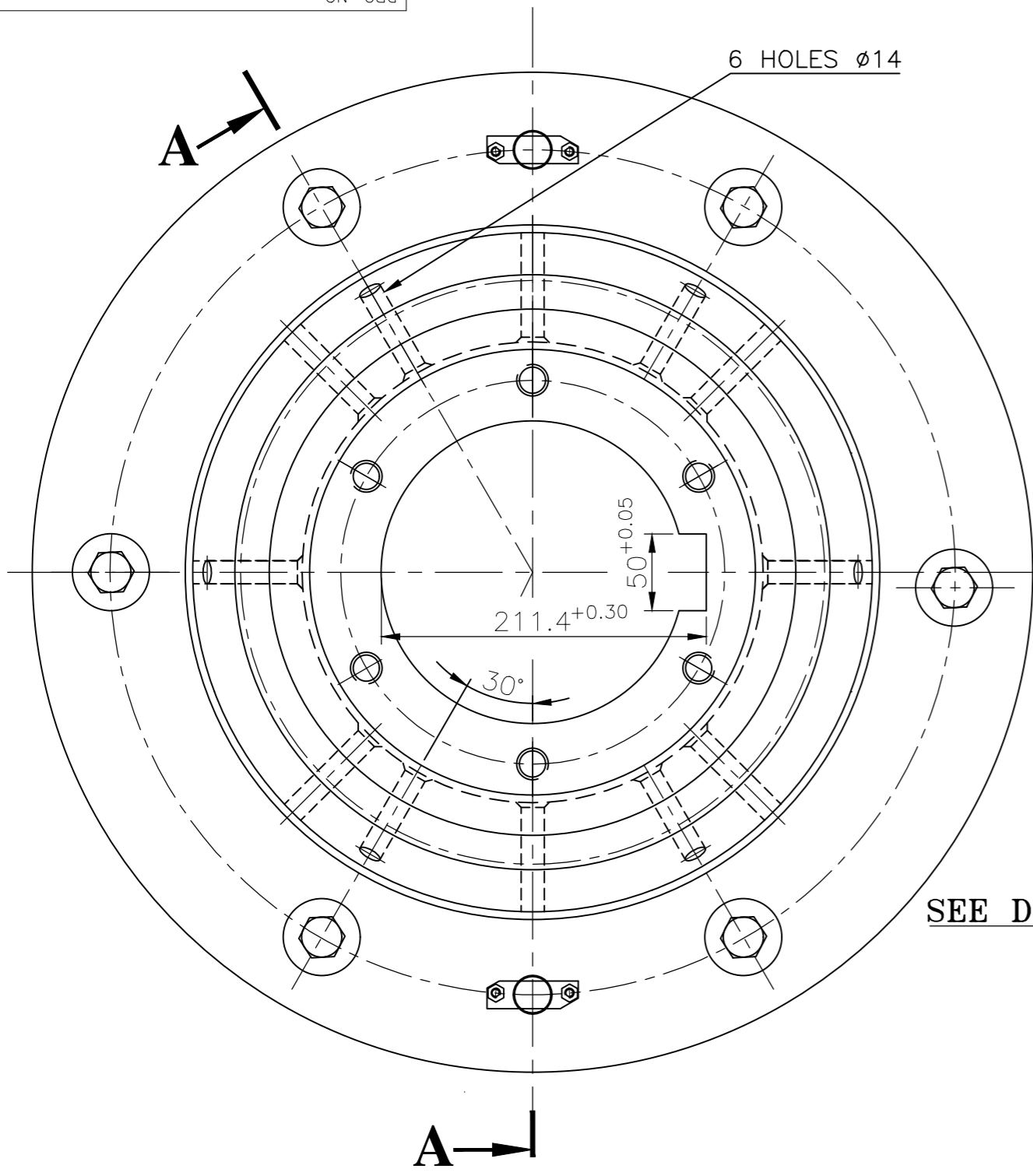

AFTER BOLTING RUNNER DISC & THRUST COLLAR TOGETHER, DRILL AND REAM 2 HOLES Ø40 ON THRUST COLLAR & RUNNER DISC TOGETHER TO THE DEPTH SHOWN FROM THE EXISTING HOLES OF THRUST COLLAR (USE BOTTOM FLAT DRILL/REAMER) HOLES MUST NOT BREAK THROUGH. DOWEL IT. 06 TO BE GROUND TO GIVE A TRANSITION FIT OF ±0.02 ON MEASURED DIA. OF HOLE.

TECH. REQUIREMENTS :-

- 1 - ALL SURFACES SHALL BE COATED WITH ANTI RUST COMPOUND LIKE TECTYL 511-M OR EQUIVALENT.
- 2 - NON-PARALLELITY AND NON-CENTRICITY OF SURFACE 'A' W.R.T. SURFACE 'B' SHALL NOT EXCEED 0.03mm.
- 3 - DIMENSION MEASUREMENT SHALL BE DONE ON 3D CMM.
- 4 - DIMENSIONS WITHIN BRACKET ARE FOR REFERENCE ONLY.
- 5 - RECORD I.R. VALUE WITH A 500V MEGGER AS FOLLOWS:-
 - a) INDIVIDUAL DOWEL TO GROUND.
 - b) THRUST COLLAR TO GROUND.
 THE VALUE SHOULD BE MORE THAN 1 MEGA OHM.

STYLE NO. BP9503036852

GES NO. 404211354 VAR.00

VAR	NO.	REMARKS	VAR NO.	ITEM NO.	DESCRIPTION	STD.	DRAWING NO.	IT.NO.	MATL. CODE	UNIT	UNIT WT.	QTY.	ZONE
	02			09	INSULATED LOCKING		44025446016	01			0.02		
	04			08	SCREW HEX. AM 10X20-8.8				AA7121123215 AA7121123				
	02			07	LOCKING PLATE		44025442108	01					
	02			06	INSULATED DOWEL ASSY.		34025446009	00			1.25		
	06			05	WASHER MCD. 21				AA7161001099 AA7161001				
	06			04	INSULATION WASHER		44020546257	01					
	06			03	INSULATION BOLT M20X70		44020542352	01					
	01	GES NO. 404211355		02	THRUST BEARING RUNNER M/C.		24025440062	00			75.0		
	01			01	THRUST BUSH PRELIMINARY M/CING.		24025442040	01			430.0		

ADDITION INFORMATION STANDARD		TYPE OF PRODUCT OR NAME OF CUSTOMER/PROJECT STANDARD	
STATUS OF DRAWING		DISTRIBUTION OF PRINT O.C.- 1 FMM-4	
TEX-3		BHARAT HEAVY ELECTRICALS LTD. BHOPAL	
DEPT. AME	GRADE OF UNTOL.	SCALE N T S	WEIGHT (kg) 495
CODE 404	DIM. ϕ /M/F		
TITLE THRUST BUSH FOR THRUST & GUIDE BRG. ASSY.		DRAWING NO. 24025442039	
SHEET NO. 01		NO. OF SHEET 01	

INVENTORY NO. 24025442036 REF. DRG. NO. SIGN. & DATE

REV	DATE	ALTERED CHECKED APPROVED	REV	DATE	ALTERED CHECKED APPROVED	REV	DATE	ALTERED CHECKED APPROVED	REV	DATE	ALTERED CHECKED APPROVED

RV/BRG./24025442039

SIZE A2

34028042043

DRG. NO.

THE INFORMATION ON THIS DOCUMENT IS THE PROPERTY OF BHARAT HEAVY ELECTRICALS LIMITED. IT MUST NOT BE USED DIRECTLY OR INDIRECTLY IN ANY WAY DETRIMENTAL TO THE INTEREST OF THE COMPANY.

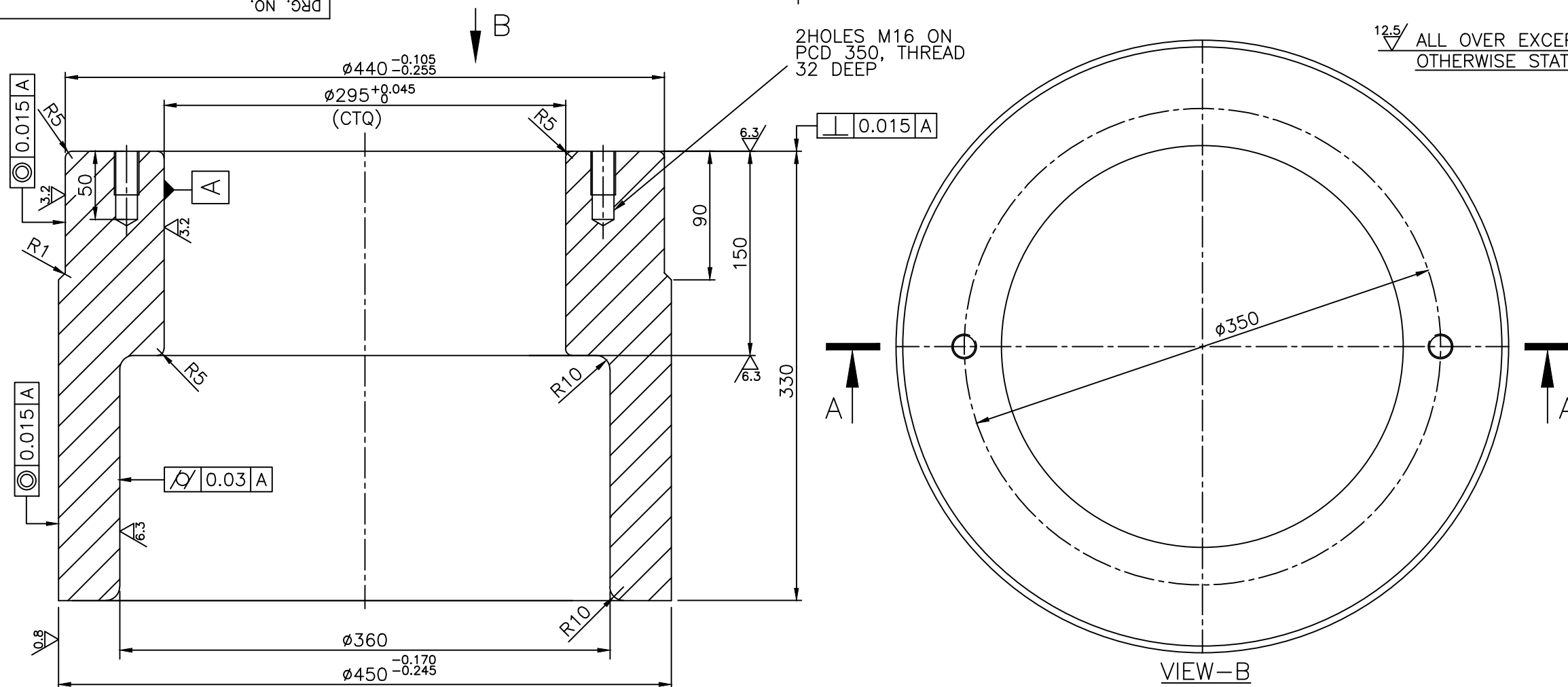

SECTION-AA

VIEW-B

TECH. REQUIREMENTS:-

- INTERNAL SURFACES EXCEPT FITTING SURFACES SHALL BE COATED WITH RED OXIDE PRIMER AS PER AA56102, FOLLOWED WITH A COAT OF OIL RESISTANT ENAMEL (IN BHEL SCOPE).
- DIMENSIONS WITHIN BRACKET ARE RAW MATERIAL DIMENSIONS.
- DIMENSION MEASUREMENT SHALL BE DONE ON 3D CMM.
- ITEM TO BE SUPPLIED IN FULLY FINISHED CONDITION. RAW MATERIAL IS ALSO IN SUPPLIER'S SCOPE.

STYLE NO : BP9503036658

01	B.O.	01	BUSH (FORGING)	34028042041	01	215.00																	
59	64	65	75	78	79	25	27	29	58	59	60	77	29	31	34	MATL. CODE	45	55	56-57	58	UNIT WT.	65	72
VAR 00	REMARKS		VAR NO.	ITEM NO.	DESCRIPTION	STD.	DRAWING NO.	VAR	MATL. SPCN.	C	UNIT	QTY.	GS	ZONE									
28 ——— CARD TYPE-3						28 ——— CARD TYPE-1						28 ——— CARD TYPE-2											

34028042029

REF. DRG. NO.

SIGN. & DATE

INVENTORY NO.

REV	DATE	ALTERED	Y M	REV	DATE	ALTERED	AJAY
05	17.06.2024	CHECKED	VP	04	07.10.2015	CHECKED	MHN
		APPROVED				APPROVED	MN
DRG. TITLE UPDATED. TR.4 ADDED.				TITLE CHANGED.			
03	23.09.15	CHECKED	MHN	02	11.09.15	CHECKED	MHN
		APPROVED	MN			APPROVED	MN
WEIGHT CORRECTED.				STYLE NO. ADDED			

ADDITION INFORMATION W.O. STD.		TYPE OF PRODUCT OR NAME OF CUSTOMER/PROJECT STD. M/S. STD.	
STATUS OF DRAWING AME-1 TEX(PLM)-4		DISTRIBUTION OF PRINT AME-1 TEX(PLM)-4	
DEPT. AME CODE 404		GRADE OF UNTOL. DIM. φ/M/F	
SCALE NTS		WEIGHT (kg) 182.00	
REF. TO ASSY. DRG.		ITEM NO.	
DRAWING NO. 34028042043		NO. OF ITEMS 05	
SHEET NO.		NO. OF SHEET	

SYN./BUSH/34028042043

FIRST ANGLE PROJECTION

(ALL DIMENSIONS ARE IN mm)

DRG. NO. 34028042044

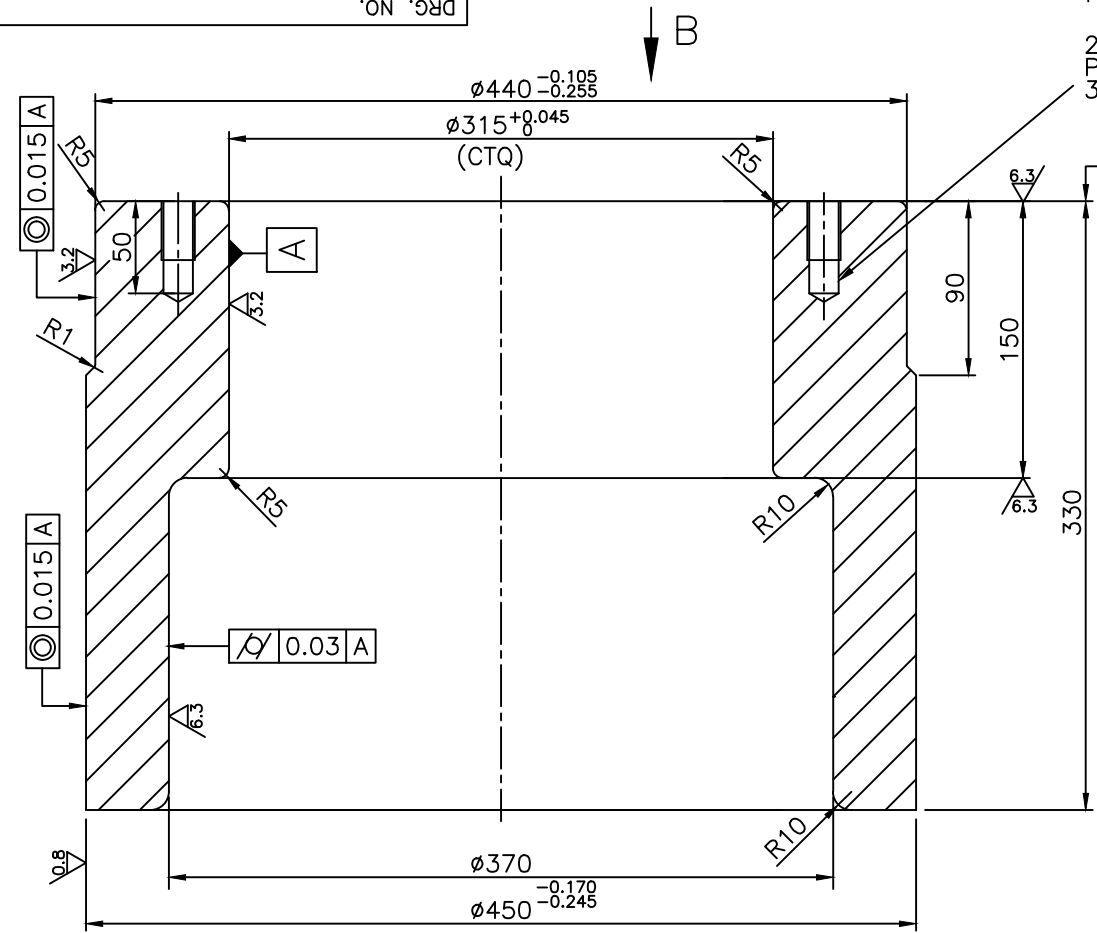

2HOLES M16 ON PCD 370, THREAD 32 DEEP

12.5/ ALL OVER EXCEPT OTHERWISE STATED.

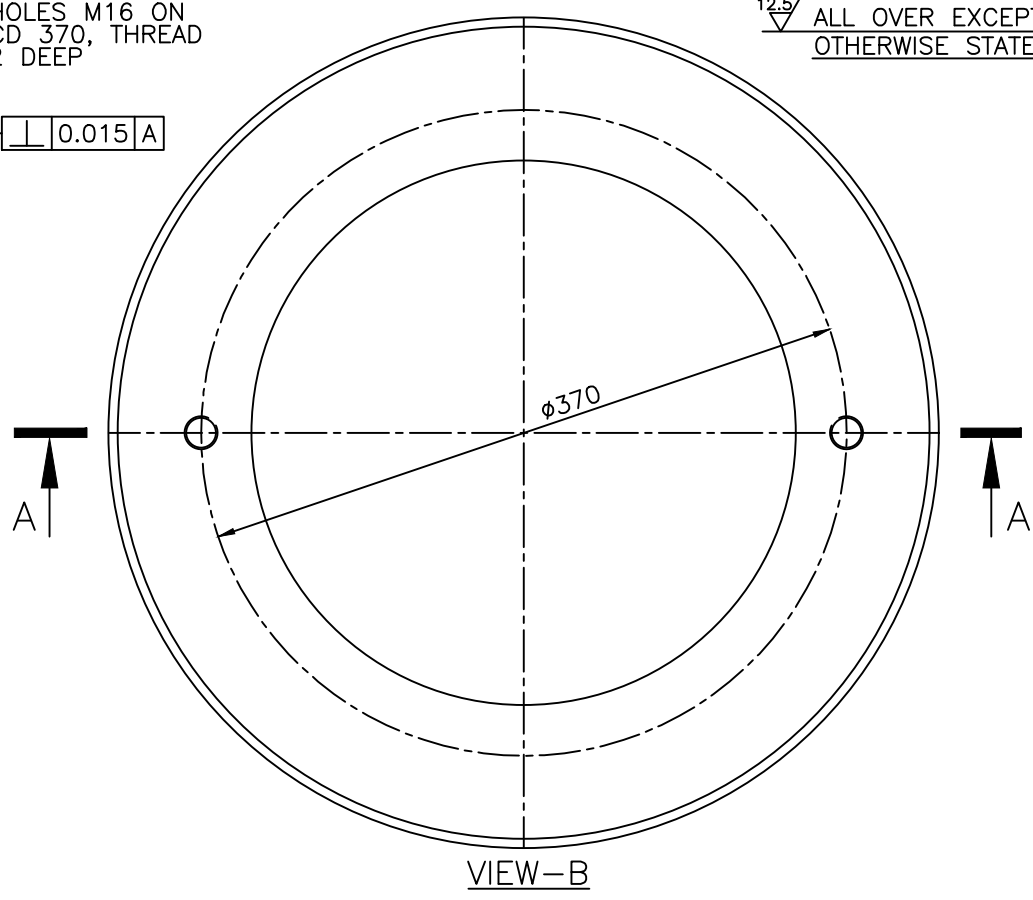

SECTION-AA

VIEW-B

THE INFORMATION ON THIS DOCUMENT IS THE PROPERTY OF BHARAT HEAVY ELECTRICALS LIMITED. IT MUST NOT BE USED DIRECTLY OR INDIRECTLY IN ANY WAY DETRIMENTAL TO THE INTEREST OF THE COMPANY.

TECH. REQUIREMENTS:-

- INTERNAL SURFACES EXCEPT FITTING SURFACES SHALL BE COATED WITH RED OXIDE PRIMER AS PER AA56102, FOLLOWED WITH A COAT OF OIL RESISTANT ENAMEL (IN BHEL SCOPE).
- DIMENSIONS WITHIN BRACKET ARE RAW MATERIAL DIMENSIONS.
- DIMENSION MEASUREMENT SHALL BE DONE ON 3D CMM.
- ITEM TO BE SUPPLIED IN FULLY FINISHED CONDITION. RAW MATERIAL IS ALSO IN SUPPLIER'S SCOPE.

STYLE NO; BP9503036606

34028042029 REF. DRG. NO. SIGN. & DATE INVENTORY NO.

01	B.O.	01	BUSH (FORGING)	34028042041	01	215																
59	64	65	75	78	79	25	27	29	58	59	60	77	29	31	34	45	55	56	57	58	65	72
VAR 00	REMARKS		VAR NO.	ITEM NO.	DESCRIPTION	STD.	DRAWING NO.	IT.NO.	MATL. CODE	A	UNIT	QTY.	GS	ZONE								
28 CARD TYPE-3						28 CARD TYPE-1						28 CARD TYPE-2										

REV 04			DATE	17.06.24	ALTERED YM		CHECKED VP		APPROVED		ADDITION INFORMATION			TYPE OF PRODUCT			NAME OF CUSTOMER/PROJECT																																				
											W.O.41020 P 423-41			1TC4938			M/S. RAICHUR POWER																																				
											DRG. TITLE UPDATED, TR.4 ADDED			DISTRIBUTION OF PRINT			Bharat Heavy Electricals Ltd.																																				
											AME-1			BHPAL			DRN BRP																																				
											TEX(PLM)-4			APPD VA			DATE 04.10.12																																				
REV 03			DATE	07.10.2015	ALTERED AJAY		CHECKED MHN		APPROVED MN		REV 02			DATE	23.09.15	ALTERED AJAY		CHECKED MHN		APPROVED MN		REV 01			DATE	7.08.15	ALTERED AJAY		CHECKED MHN		APPROVED MN		DEPT. AME			GRADE OF UNTOL.			SCALE			WEIGHT (kg)			REF. TO ASSY. DRG.			ITEM NO.			NO. OF ITEMS		



BHARAT HEAVY ELECTRICALS LIMITED, BHOPAL
QUALITY ASSURANCE – MOTOR GROUP

QUALITY PLAN FOR THRUST BUSH MACHINING

CUSTOMER:	BHEL, BHOPAL	QAP NO.:	QA/MT/BOI/040 REV NO.:00		LEGEND								
		DATE	25/03/2016		M: MANUFACTURER		RR: RECORD REVIEW		P- PERFORM				
SPECIFICATION:	P.O./DRAWING			B:BHEL/ BHEL APPOINTED TPIA		W: WITNESS		PAGE 1 OF 1					
SL NO	COMPONENTS	CHARACTERISTIC	CLASS	TYPE OF CHECK	QUANTUM OF CHECK		REFERENCE DOCUMENT	ACCEPTANCE NORMS	FORMAT OF RECORD	D*	AGENCY		REMARKS
					M	B					M	B	
1.0 FINAL INSPECTION													
1.1	Dimensions, Concentricity, Perpendicularity, parallelism (3D CMM Report) in assembled condition of Bush and thrust runner		Critical	Meas.	100%	100%	As per BHEL Drg.	As per BHEL Drg.	SUPP. TC	√	P	W	
1.2	Surface Finish		Critical	Meas.	100%	100%	As per BHEL Drg.	As per BHEL Drg.	SUPP. TC	√	P	W	
1.3	IR measurement	Insulation Resistance	Major	Electrical test	100%	100%	As per BHEL Drg.	As per BHEL Drg.	SUPP. TC	√	P	W	
1.4	Hardware	Identification Check	Major	Visual	100%	100%	As per BHEL Drg.	All bolts have head embossed with property class 8.8 and above.	SUPP. TC	√	P	W	
1.5	Primer coating	Application of red oxide primer	Major	Visual	100%	100%	As per BHEL Drg.	As per BHEL Drg.	SUPP. TC	√	P	W	
1.6	Identification	Transfer of identification from forged Bush material to Machined Upper face of Bush	Major	Visual	100%	100%	-----	-----	SUPP. TC	√	P	W	
1.7	Packing and Despatch	Wooden Box	Major	Visual	100%	100%	-----	-----	SUPP. TC	√	P	R	Packing should be strong enough to protect the item from damage

PREPARED BY

* RECORDS, IDENTIFIED WITH "TICK" (√) SHALL BE ESSENTIALLY INCLUDED BY SUPPLIER IN QA DOCUMENTATION.

APPROVED BY

आशीष मोहन तेलगोटे / A.M. TELGOTE
जंरि. अभियंता-गु.अ. / Sr. Engineer-QA
गुणता आश्वासन-मोटर / Quality Assurance-Motors
डी.एच.ई.एल. भोपाल / BHEL, BHOPAL

P.A. TOPPO / P.A. TOPPO
जंरि. अभियंता / Asst. General Manager
गुणता आश्वासन / QA & QIC
डी.एच.ई.एल. भोपाल / BHEL, BHOPAL



BHARAT HEAVY ELECTRICALS LIMITED, BHOPAL
QUALITY ASSURANCE – MOTOR GROUP

QUALITY PLAN FOR GUIDE BUSH MACHINING

CUSTOMER:		BHEL, BHOPAL		QAP NO.: QA/MT/BOI/010 REV NO.:01		LEGEND							
SPECIFICATION:		P.O./DRAWING		B:BHEL/ BHEL APPOINTED TPIA		M: MANUFACTURER		RR: RECORD REVIEW		P- PERFORM		PAGE 1 OF 1	
SL NO	COMPONENTS	CHARACTERISTIC	CLASS	TYPE OF CHECK	QUANTUM OF CHECK		REFERENCE DOCUMENT	ACCEPTANCE NORMS	FORMAT OF RECORD	D*	AGENCY		REMARKS
					M	B					M	B	
1.0 RAW MATERIAL INSPECTION													
1.1	Bush Forging	Chem. composition	major	test	1 Sample/Heat	1 Sample/Heat	BP19388	BP19388	Supplier	√	P	W	
		Mech. properties			1 Sample/Heat	1 Sample/Heat							
		UT			100%	100%							
2.0 FINAL INSPECTION													
2.1		Dimensions, Concentricity, Perpendicularity, cylindricity. (3D CMM report)	Critical	Meas.	100%	100%	As per BHEL Drg.	As per BHEL Drg.	SUPP. TC	√	P	W	
2.2		Surface Finish	Critical	Meas.	100%	100%	As per BHEL Drg.	As per BHEL Drg.	SUPP. TC	√	P	W	
2.3	Primer coating	Application of red oxide primer	Major	Visual	100%	100%	As per BHEL Drg.	As per BHEL Drg.	SUPP. TC	√	P	W	
2.4	Identification	Punching P.O.No. Size, spec on upper surface of bush	Major	Visual	100%	100%	-----	-----	SUPP. TC	√	P	W	
2.5	Packing and Despatch	Wooden Box	Major	Visual	100%	100%	-----	-----	SUPP. TC	√	P	R	Packing should be strong enough to protect the item from damage

* RECORDS, IDENTIFIED WITH "TICK" (√) SHALL BE ESSENTIALLY INCLUDED BY SUPPLIER IN QA DOCUMENTATION.

PREPARED BY

आशीष तेलगोटे / A.M. TELGOTE
भ.इ. कनिष्ठ-प्र.अ. / Sr. Engineer-QA
गुणता आश्वासन-मंडल / Quality Assurance-Motor
बी.एच.ई.एल., भोपाल / B.H.E.L., BHOPAL

APPROVED BY

आशीष तेलगोटे / A.M. TELGOTE
भ.इ. कनिष्ठ-प्र.अ. / Sr. Engineer-QA
गुणता आश्वासन-मंडल / Quality Assurance-Motor
बी.एच.ई.एल., भोपाल / B.H.E.L., BHOPAL

BHEL Enquiry No.:

With reference to above enquiry, we M/s (Bidder's Name) confirm/declare the following:-

<p style="text-align: center;"><u>Treatment of cases regarding conflict of interest:</u></p> <p><i>The bidder notes that a conflict of interest would said to have occurred in the tender process and execution of the resultant contract, in case of any of the following situations:</i></p> <p><i>i) If its personnel have a close personal, financial, or business relationship with any personnel of BHEL who are directly or indirectly related to the procurement or execution process of the contract, which can affect the decision of BHEL directly or indirectly;</i></p> <p><i>ii) The bidder (or his allied firm) provided services for the need assessment/ procurement planning of the Tender process in which it is participating;</i></p> <p><i>iii) Procurement of goods directly from the manufacturers/ suppliers shall be preferred. However, if the OEM/ Principal insists on engaging the services of an agent, such agent shall not be allowed to represent more than one manufacturer/ supplier in the same tender. Moreover, either the agent could bid on behalf of the manufacturer/ supplier or the manufacturer/ supplier could bid directly but not both. In case bids are received from both the manufacturer/ supplier and the agent, bid received from the agent shall be ignored. However, this shall not debar more than one Authorized distributor (with/ or without the OEM) from quoting equipment manufactured by an Original Equipment Manufacturer (OEM) in procurements under a Proprietary Article Certificate.</i></p> <p><i>iv) A bidder participates in more than one bid in this tender process. Participation in any capacity by a Bidder (including the participation of a Bidder as a partner/ JV member or sub-contractor in another bid or vice-versa) in more than one bid shall result in the disqualification of all bids in which he is a party. However, this does not limit the participation of an entity as a sub-contractor in more than one bid if he is not bidding independently in his own name or as a member of a JV. The Bidder declares that they have read and understood the above aspects, and the bidder confirms that such conflict of interest does not exist and undertakes that they will not enter into any illegal or undisclosed agreement or understanding, whether formal or informal with other Bidder(s), in this regard. This applies in particular to prices, specifications, certifications, Subsidiary contracts, submission or non-submission of bids or any other actions to restrict competitiveness or to introduce cartelization in the bidding process. In case, the Bidder is found having indulged in above activities, the same will be considered as a violation of the tender conditions, and suitable action shall be taken by BHEL as per extant policies/ guidelines.</i></p>	<p>Confirm</p>
<p style="text-align: center;">Instructions for document submission for payments</p> <p>For supply orders placed on Indian Suppliers: Irrespective of the value of the invoice amount, the bidder / vendor should necessarily upload the despatch & invoice details on BHEL SUVIDHA portal at https://suvidha.bhel.in/suvidha/, prior to despatch. All documents as per PO checklist , along with additional documents (if any), must be uploaded on the portal. It is mandatory that tax invoices with a net amount (including taxes) exceeding Rs five lakhs uploaded on the portal are digitally signed using a Class 3 Digital Signature Certificate (DSC) issued by a licensed Certifying Authority. Submission of invoice document in hard copy is allowed for invoices with a net amount (including taxes) equal to and up to Rs five lakhs , in case they were not digitally signed and uploaded on the portal.</p> <p><i>The material will not be accepted inside BHEL in absence of the above.</i></p>	<p>Confirm</p>

Yours very truly,

..... (authorized signatory of company with seal)

..... (firm name)

Authorized signatory of company



BP 200102C

BHARAT HEAVY ELECTRICALS LIMITED, BHOPAL GENERAL TERMS AND CONDITIONS OF ENQUIRY

Annexure 1

Format - Self Certificate for MII

CERTIFICATION REGARDING MINIMUM LOCAL CONTENT IN LINE WITH REVISED PUBLIC PROCUREMENT (PREFERENCE TO MAKE IN INDIA), ORDER 2017 DATED 19.7.24 AND SUBSEQUENT ORDER(S)

(To be provided on the Letter Head of the Entity/Firm)

To,

_____ (Write Name and Designation of Officer of BHEL inviting the Tender);

Bharat Heavy Electricals Limited,
Piplani, Bhopal, MP-462022

Ref : 1) BHEL NIT/Tender Specification No:
2) Name of items :
3) All other pertinent issues till date

We hereby certify that the items/works/services offered by..... (specify the name of the organization here) has a local content of _____ % .

The local content % certified above is in line with definition of Local content given in point no 2 of Public Procurement (Preference to Make in India), Order 2017 Revision dated 19.7.2024 issued by DPIIT and subsequent order(s) to qualify as (Class-I/ CLASS-I II/ Non-Local supplier-fill in one which is applicable) local supplier.

The details of the location(s) at which the local value addition is made are as follows:

We confirm that the following has not been considered for calculation of local content:

- Imported items sourced locally from resellers/distributors.
- The license fees/ royalties paid/ technical charges paid out of India
- Refurbishment/Repackaging/ Rebranding of imported products
- services such as transportation, insurance, installation, commissioning, training and after sales service support like AMC/CMC etc.

**We confirm that since contract involves supply of multiple items, weighted average of all items has been taken while calculating the local content.

I hereby declare that the details furnished above are true and correct to the best of my knowledge and belief. In case any of the above information is found to be false or untrue or misleading or misrepresenting, I am aware that I may be held liable for it.

(Signature, Name, Designation, Date, Place & Seal of
Authorized Signatory of the Bidder)

** - Strike out whichever is not applicable

Note: For evaluation of qualification of bidder:

1. Bidder has to submit the above format, duly filled & signed by authorized signatory.
2. For items sold by bidder as reseller, OEM certificate for country of origin to be submitted.

DECLARATION BY VENDOR

We declare that the following family firms or sister concern affiliates / subsidiary firms are participating in the tender No E.....:

1.0

2.0

3.0

.....

I, hereby declare on behalf of M/s and the family firms or sister concern affiliates / subsidiary firms listed above that we are not indulging in cartel formation for Enquiry No E.....

(.....)

For M/s

(Seal & Sign)





BP 200102C

**BHARAT HEAVY ELECTRICALS LIMITED, BHOPAL
GENERAL TERMS AND CONDITIONS OF ENQUIRY****TABLE OF CONTENTS**

<u>Sl no</u>	<u>Description</u>
<u>1</u>	General
<u>2</u>	General Instructions - Common for Indigenous & Foreign enquiries
<u>2.1</u>	Through eProcurement
2.2	Through tender room (Conventional tender)
2.3	Through tender room or e- Procurement
3	Delivery Term
3.1	Indigenous Purchase
3.2	Foreign Purchase — Imports
4	Bidder's particulars & logistics information (Bidder to give details against each of the provisions)
5	Additional logistics information for Imports
6	Delivery Schedule & Completion date
7	Transit Insurance
8	Force Majeure
9	Penalty for Late Delivery
10	Indian Agents and Agency commission
11	Documentation:
11.1	Indigenous Purchase
11.2	Foreign Purchase — Imports
11.3	General
12	Pricing Terms
13	Price Validity
14	Taxes & Duties - Indigenous Purchase
15.	Taxes & Duties - Foreign Purchase — Imports
16	Payment Terms-
17	Inspection of Goods
18	Guarantee / Warranty and corresponding Repairs / Replacement of Goods
19.1	Evaluation and Loading Criteria:
20	Variation of orders
21	Sub-contract
22	Recovery / deductions of amount from supplier
23	Safety clause for purchase orders
24	Non-Disclosure Agreement
25	Settlement of Disputes & Arbitration
26	Applicable Laws and Jurisdiction of Courts
27	RIGHT OF REJECTION /NON- PLACEMENT OF PO:
28	Performance Bank Guarantee (PBG)/ Security Deposit (SD):
29	Benefits earmarked for Purchase from Micro & Small Enterprises (MSEs) –
30	Integrity Pact (IP) — Independent external monitors (IEM)
31	Fraud Prevention Policy:
32	Integrity Commitment:
33	Public Procurement (Preference to Make in India), Order 2017
34	RESTRICTION UNDER RULE 144 (xi) OF THE GENERAL FINANCIAL RULES 2017:
35	Conflict of Interest:
36	Breach of contract, Remedies and Termination
37	Option clause:
38	NOTE:
39	Grievance Redressal Mechanism



BP 200102C

**BHARAT HEAVY ELECTRICALS LIMITED, BHOPAL
GENERAL TERMS AND CONDITIONS OF ENQUIRY**

Sl. No.	Description
1	General:
1.1	<p>These General Terms & Conditions (GTC) shall apply to all enquiries, notice inviting tenders, request for quotations concerning the supply of goods and / or rendering of services to Bharat Heavy Electricals Ltd., Bhopal (hereinafter referred to as BHEL or the Purchaser) or its Projects / Customers. Special / supplementary enquiry conditions, if any, will override the conditions in this annexure. In case of placement of order these conditions will become part of Purchase Order (PO) until unless the deviations are specifically agreed by BHEL.</p> <p>In case of any inconsistency, conflicts or contradiction among any of the contract documents, the interpretations will be based on the following order of precedence:</p> <ol style="list-style-type: none">Amendments to Purchase Order/ Framework agreementPurchase Order/ Framework AgreementLetter of intent (LOI)/ Letter of Award (LOA)Minutes of meeting or Clarifications agreed between Buyer and Seller as regards to the tender or the bidding conditionsCorrigenda to NIT, with those of later date having precedence over those of earlier dateOriginal NIT and annexures except documents listed in point no (vii) to (ix) belowTechnical specifications including their annexuresSpecial Terms and condition of Enquiry (STC)General Terms of Enquiry (GTC)
2	General Instructions - Common for Indigenous & Foreign enquiries
2.1	Through eProcurement <ol style="list-style-type: none">Interested bidders / suppliers shall submit their offer through e-procurement mode at https://eprocurebhel.co.in/nicgep/appOffers in any other mode will not be accepted.Procedure for submission of tender is available in the "Bidder Manual Kit" at e-tender portal https://eprocurebhel.co.in/.In case of any difficulty faced while registering on BHEL's e-Procurement portal developed by NIC, queries may be addressed to 0120-4001002, 0120-4001005 and 0120-4493395 email: support- eproc@nic.in. These details are also available on Contact Us page of the portal.Before uploading scanned documents if any, the bidders shall sign on all the statements, documents, certificates etc uploaded by him, owning responsibility for their correctness / authenticity.Disclaimer clause: Neither the Organization (Bharat Heavy Electricals Ltd.) nor the service provider is responsible for any failure of submission of bids due to failure of internet or other connectivity problems or reasons thereof.
2.2	Through tender room (Conventional tender)
2.2.1	<p>Sealed bids are invited for scope of Supply / Services as detailed in the enquiry. Bid should be free from correction, overwriting, using of corrective fluid etc. Any interlineation, cutting, overwriting shall be valid only if they are attested under full signature(s) of persons signing the bid else shall be liable for rejection.</p> <p>All overwriting/ cutting etc. will be numbered by bid opening officials and announced during bid opening. The bid should be submitted in English or Hindi language. Relevant enclosures, supporting documents, catalogue, samples, if any, as required as per Notice Inviting Tender (NIT) conditions shall be sent along with technical offer. Rate should be quoted in the units asked for in the enquiry.</p>



BP 200102C

BHARAT HEAVY ELECTRICALS LIMITED, BHOPAL GENERAL TERMS AND CONDITIONS OF ENQUIRY

2.2.2	<p>Bids shall be submitted in a Sealed cover with Enquiry No., Due date and Bidder's name indicated on the cover. In case of Two-Part Bid, technical bid containing technical offer, this GTC duly filled-in & signed; and un-priced copy of the Price Bid should be kept in one envelope. Price Bid containing only the price (as called for in the price format where required) should be kept in a separate envelope. Both envelopes indicating Part —I or Part-II as the case may be to be put in a bigger envelope, which should be addressed to in charge, Tender Room, Bharat Heavy Electricals Ltd. 2nd Floor, Jawahar Bhavan, Piplani, Bhopal 462022. Enquiry No., due date and bidder's name must be mentioned on all envelopes.</p> <p>Offer must reach tender room of BHEL Bhopal latest by 11.00 am IST on the enquiry due date.</p> <p>Bids submitted as single part bid against two – part bid, shall be rejected unless the offer is techno-commercially acceptable without seeking any clarification.</p>
2.2.3	<p>Offer received after 11.00 AM IST of the due date will be termed as "Late" and shall not be considered. However, late offer received against single tender enquiry may be considered.</p>
2.2.4	<p>Bidder can also submit offer through email id mmtender.bpl@bhel.in or if called for in the enquiry, at the designated /authorized email address indicated in the enquiry. Such email offers shall be sent only on designated email-id to reach before 11.00 am IST on the tender due date. BHEL will not be responsible for incomplete offers and the ones delivered late through e-mail. Bidder shall have no claim on e-mail offers sent to any other e-mail ID. In case of e-mail offers, the mail subject should contain Enquiry Number, Due date and Bidder name. Bidder address including contact details shall be mentioned in the content of the mail. Without these details, the offer is liable for rejection. All techno commercial terms & conditions mutually agreed prior to price bid opening shall prevail and supersede any terms and conditions specified otherwise in price bid.</p>
2.3	Through tender room or e- Procurement
2.3.1	<p>Commercial Conditions quoted by the bidder in any place including as stated in bidder's 'General Terms and Conditions' if any, shall not be binding on the Purchaser and the conditions contained in this annexure, including special conditions, if any, for this enquiry shall only prevail.</p>
2.3.2	<p>Rate should be quoted in the units asked for in the enquiry. The rates should be quoted both in figures and words. In case of discrepancy in figures and words, the rates quoted in words shall be considered.</p>
2.3.3	<p>The goods offered shall conform to BHEL specifications and / or National/International standards as mentioned in the Enquiry and the bidder is required to confirm his unconditional acceptance to the same. Bidders, seeking deviations from the specifications and any other conditions, may indicate the same clearly on a separate sheet indicating Sl. No. of the item, with reasons for such deviations. BHEL reserves the right to reject the offer with deviations or load the deviations suitably for evaluation.</p>
2.3.4	<p>Offers shall be submitted directly by bidder or his authorized agent only. Unsolicited offers shall be summarily rejected.</p>
2.3.5	<p>Bid in single part or techno-commercial bid in two-part system (as the case may be) will be opened on the due date. In case of two-part bid, price bids of techno-commercially accepted bidder(s) only shall be opened on the assigned date, for which separate intimation will be sent to the accepted bidders.</p>



BP 200102C

BHARAT HEAVY ELECTRICALS LIMITED, BHOPAL GENERAL TERMS AND CONDITIONS OF ENQUIRY

2.3.6	<p>Whenever specified /called in special /additional /tender specific remakes of tender the Bid Security/ Earnest Money Deposit (EMD)] is to be submitted by bidders along with their bids (except Micro and Small Enterprises (MSEs) or Start-ups as recognized by Department for Promotion of Industry and Internal Trade (DPIIT)).</p> <p><u>Modes of deposit</u></p> <p>a) The EMD may be accepted only in the following forms:</p> <p>(i) Electronic Fund Transfer credited in BHEL account (before tender opening).</p> <p>(ii) Banker's cheque/ Pay order/ Demand draft, in favour of BHEL (along with offer).</p> <p>(iii) Fixed Deposit Receipt (FDR).</p> <p>(iv) Bank Guarantee from any of the Scheduled Banks.</p> <p>(v) Insurance Surety Bonds.</p> <p>b) In case the EMD is more than Rupees Two lakh and in case of foreign bidders, it may be in the form of a bank guarantee (in equivalent Foreign Exchange amount, in case of foreign bidders) issued/ confirmed from any of the scheduled commercial bank in India in an acceptable form. The EMD shall remain valid for a period of 45 (forty-five) days beyond the final bid validity period.</p> <p><u>Forfeiture of EMD</u></p> <p>(i) A bidder's EMD will be forfeited if the bidder withdraws or amends its/ his tender or impairs or derogates from the tender in any respect within the period of validity of the tender or if the successful bidder fails to furnish the required performance security within the specified period mentioned in the Tender.</p> <p>(ii) EMD by the tenderer to be withheld in case any action on the bidder is envisaged under the provisions of extant "Guidelines on Suspension of business dealings with suppliers/ contractors" and forfeited/ released based on the action as determined under these guidelines.</p> <p><u>Others Instructions</u></p> <p>(i) Bid securities of the unsuccessful bidders should be returned to them at the earliest after expiry of the final bid validity period and latest by the 30th day after the award of the contract. However, in case of two packet or two stage bidding, bid securities of unsuccessful bidders during first stage i.e. technical evaluation etc. will be returned within 30 days of declaration of result of first stage i.e. technical evaluation etc.</p> <p>(ii) Bid security will be refunded to the successful bidder on conclusion of the order/ receipt of a performance security (if called in the tender).</p> <p>(iii) EMD shall not carry any interest.</p>
2.3.7	<p>1.Any discount / revised offer submitted by a bidder on its own shall be considered, provided it is received on or before the due date and time of offer submission (Part-I). Conditional discounts shall not be considered for evaluation of tenders.</p> <p>2.Unsolicited discounts / revised offers given after Part-I bid opening shall not be accepted. No change in price will be permitted within the validity period of offer.</p> <p>3.In case of changes in scope and / or technical specification and / or commercial terms & conditions, having price implication, techno-commercially acceptable bidders shall be asked by BHEL to submit the impact of such changes on their price bids. In case a bidder opts to submit revised price bid instead of impact called for, then latest price bid shall prevail. However, in both situations, original price bid will be necessarily opened.</p>
2.3.8	<p>The bidders will submit Integrity Pact, duly signed by its authorized signatory, where called for in the enquiry.</p>
2.3.9	<p>Unregistered suppliers, who are techno-commercially qualified against the open tender, are requested to register with BHEL-Bhopal as permanent supplier by submitting the Supplier Registration Form (SRF) in online supplier registration portal (https://supplier.bhel.in/). Un-registered vendors may be approved by BHEL, if found suitable, on the basis of data furnished by them in Supplier Registration Form (SRF) for Foreign Vendors or Indigenous Vendors (as applicable)</p>
2.3.10	<p>BHEL expects that the bidder responds to the enquiry. Regret letter, with valid reasons for not participating in the tender will be submitted where the bidder is unable to submit offer. Repeated lack of response on the part of bidder may lead to his deletion from BHEL's approved bidder list. Refer guidelines for suspension of Business Dealings with Suppliers/Contractors available on https://www.bhel.com/sites/default/files/suspension_guidelines_abridged.pdf</p>
2.3.11	<p>In case of open tenders (i.e. those published in website) all corrigenda, addenda, amendments, time extensions, clarifications etc. to the tender will be hosted on BHEL website. (https://bhel.com/tenders) and additional in https://eprocurebhel.co.in/nicgep/app for e-procurement tenders. Bidders responding to these tenders should regularly visit website(s) to keep themselves updated.</p>



BP 200102C

**BHARAT HEAVY ELECTRICALS LIMITED, BHOPAL
GENERAL TERMS AND CONDITIONS OF ENQUIRY**

2.3.12	In the course of evaluation, if more than one bidder happens to occupy L-1 status effective L-1 will be decided by soliciting discounts from the respective L-1 bidders in sealed envelope and will be open in tender room. In case more than one bidder happens to occupy the L-1 status even after soliciting discounts, the L-1 bidder shall be decided by a toss/ draw of lots, in presence of the respective L-1 bidders or their representatives. Ranking will be done accordingly. BHELs decision in such situations shall be final and binding.
2.3.13	The Purchaser can consider awarding tendered quantities among more than one bidder (after acceptance of L1 price by the other bidders) in the manner and proportion disclosed in the tender conditions. Purchaser can also consider awarding of part of the tendered quantity to other than L-1 bidder at L1 counter offered rates, if the quantity offered by the L-1 bidder is less than the quantity tendered for.
2.3.14	The bidder shall submit price bid strictly in the price format, wherever provided for, in the enquiry. Any attempt on the part of the bidder to alter the contents of the price bid format in any manner, which in the opinion of BHEL can vitiate the tendering process, will lead to rejection of the bid, <u>besides BHEL taking appropriate punitive action as deemed fit.</u> -Refer Guidelines for suspension of Business Dealings with Suppliers/Contractors available on https://www.bhel.com/sites/default/files/suspension_guidelines_abridged.pdf
2.4	BHEL shall be resorting to Reverse Auction (RA) (Guidelines as available on www.bhel.com). If tender specific conditions call for reverse auction, RA shall be conducted among the techno-commercially qualified bidders. Price bids of all techno-commercially qualified bidders shall be opened and same shall be considered for RA. In case any bidder(s) do(es) not participate in online Reverse Auction, their sealed envelope price bid along with applicable loading, if any, shall be considered for ranking
2.5	BHEL reserves the right to negotiate with L1 vendor or re-float the tender for items. BHEL reserves the right to decrease the tender quantity in case where negotiation is being held.
3	Delivery Terms
3.1	Indigenous Purchase
3.1.1	Goods shall be delivered on 'FOR Destination' basis to the named destination unless otherwise called for in the enquiry.
3.2	Foreign Purchase — Imports
3.2.1	<ol style="list-style-type: none">1. Goods shall be despatched by Sea, unless stated otherwise in the enquiry or purchase order.2. Terms of Delivery for Sea shipment shall be on CFR / CIF basis with 14 days' detention free period preferably at Nhava Sheva (JNPT-INNSA1) for FCL (Full Container Load) Cargo of GP & HC Containers.3. For other cases - Other than GP & HC Containers, LCL Cargo shall be delivered at Nhava Sheva (JNPT-INNSA1) & Break-bulk Cargo at Mumbai (MPT - INBOM1).4. For Air consignments, the terms of delivery shall be FCA at BHEL nominated Airport. In case of CIP, delivery shall be at Mumbai ACC (INBOM4).5. Freight amount shall be indicated separately in the offer in case of CIP/CFR/CIF.6. The number of detention free days and destination charges payable to shipping line must be mentioned in your offer and also on the Bill of Lading.7. Offer received on FOB basis may be considered on an exceptional basis. BHEL will load freight, marine insurance & shipping line port handling charges etc. to work out landed cost at Sea Port.8. Please visit BHEL Bhopal website https://bpl.bhel.com or refer special terms and conditions of tender enquiry for details of named Air ports and Sea ports. Name of the gateway port so chosen by the bidder shall be indicated by the Bidder in his offer.9. A In case of CIP/CFR/CIF, the shipping line should be ready to move the containers to consignee's nominated CFS (Container Freight Station) yard and Indian agent of shipping line should issue Cargo Arrival Notice (CAN) 7 days in advance.9b In case of CFR contract, bidder to supply the material through a Certified Sea worthy vessel age not more than 15 years.9c The invoices being issued by shipping lines must be in the name of BHEL. Otherwise, BHEL will recover loss of Input Credit on GST from the vendor.9d While booking the shipment, bidder to also finalize destination charges and the same should appear over BL or agreed tariff to be provided to BHEL before arrival of shipment. If cargo is stuffed in container, then the same should be allowed to be moved to CFS of importer's choice without any additional charges.



BP 200102C

BHARAT HEAVY ELECTRICALS LIMITED, BHOPAL GENERAL TERMS AND CONDITIONS OF ENQUIRY

	<p>9e Load port charges shall be settled by the supplier and not be passed on to BHEL in any form of destination charges.</p> <p>10. For reasons of delay in receipt of documents from suppliers or due to the same being found to be incomplete, and or faulty, the suppliers shall be responsible to reimburse all penalties, detention and demurrages / wharfages, if any paid by BHEL (for stated reasons).</p>
3.2.2	<p>1. For delivery of FCL (Full Container Load) cargo, the Bidder shall provide minimum 14 days' detention free period from the date of delivery at Port of Discharge / Place of Delivery (in case of ICD). Wherever the detention free period offered is less than 14 days, the bids shall be loaded for the period short of 14 days' period.</p> <p>2. <u>Port Congestion charges or any additional charges claimed by the shipping line at Port of Discharge / Place of Delivery shall be to the Bidder's account.</u></p>
4	Bidder's particulars & logistics information (Bidder to give details against each of the provisions)
4.1	Name of the bidder's executive to deal with this tender / project
4.2	E-mail address of the contact person
4.3	Telephone no. of the contact person
4.4	Name of location from where the goods shall be offered for inspection and dispatch
5	Additional logistics information for Imports
5.1	Bid currency
5.2	Charges applicable at discharge port up to BHEL's CFS (Container Freight Station) to be indicated in your offer and on the B/L
5.3	Name of Airport in the country of dispatch for FCA delivery terms
5.4	Estimated number, type & size of containers for delivery of tendered quantity (applicable where the goods are to be sent in FCL)
5.5	No. of packages with cumulative gross weight and CBM volume (applicable for LCL & Break-bulk shipment)
5.6	Approx. distance in km. from Bidder's works to Port of Loading
6	Delivery Schedule & Completion date
6.1	<p>i. Instead of writing specific date against delivery offered, bidder shall commit delivery period in number of days / weeks/ months to suit the delivery period indicated in the enquiry.</p> <p>ii. Commencement of delivery period shall be reckoned from the date of PO / LOI or any other agreed milestone.</p> <p>iii. Bidder shall deliver the goods in the manner and schedule agreed under the Purchase order. iv. Goods shall be delivered within contractual period or any extension thereof, if any, granted by the Purchaser.</p> <p>v. If delivery is linked to approval of documents, time for submission of such documents to be indicated and delivery period to be indicated from approval of documents. This delivery schedule will be considered for processing delivery extension, wherever applicable.</p> <p>vi. BHEL reserves the right to cancel the order if material is not delivered within PO scheduled delivery.</p> <p>vii. Suitable action against defaulting vendor will be taken as per Guidelines for suspension of Business Dealings with</p> <p style="text-align: center;">Suppliers/Contractors available on https://bhel.com/guidelines-suspension-business-dealings-supplierscontractors</p>



BP 200102C

BHARAT HEAVY ELECTRICALS LIMITED, BHOPAL GENERAL TERMS AND CONDITIONS OF ENQUIRY

6.2	In case of foreign supplies, the date of Bill of Lading (B/L) or AWB shall be taken as actual date of delivery where freight until discharge port in India is in Seller's scope like CFR/CIF/CIP delivery terms. For Ex-works/FCA/FOB or any other delivery term where freight is in buyer's scope, date of material readiness /Test certificate/ Warehouse receipt/Freight forwarder receipt may be considered as actual date of delivery (mutually agreed).
6.3	In case of Indigenous bidders, the date of delivery at named destination in India shall be taken as contractual delivery completion date where delivery terms are FOR destination. In case of 'Ex-works' delivery terms, the date of LR / RR shall be the contractual delivery completion date.
7	Transit Insurance
7.1	Except where delivery terms are agreed on CIF basis for Imports & FOR destination basis for indigenous purchases, transit insurance will be covered by BHEL under its Open Marine Transit Insurance Policy. Bidder shall inform dispatch particulars with value of consignment to the Purchaser within 07 days of dispatch for BHEL to arrange insurance coverage in its policy. Failure on the part of bidder to inform dispatch particulars will make him liable to pay for any transit damages / losses suffered by the Purchaser.
8	Force Majeure
8.1	"Force Majeure" shall mean circumstance which is: a) beyond control of either of the parties to contract, b) either of the parties could not reasonably have provided against the event before entering into the contract, c) having arisen, either of the parties could not reasonably have avoided or overcome, and d) is not substantially attributable to either of the parties And Prevents the performance of the contract, Such circumstances include but shall not be limited to: i) War, hostilities, invasion, act of foreign enemies. ii) Rebellion, terrorism, revolution, insurrection, military or usurped power, or civil war. iii) Riot, commotion or disorder by persons other than the contractor's personnel and other employees of the contractor and sub-contractors. iv) Strike or lockout not solely involving the contractor's personnel and other employees of the contractor and sub-contractors. v) Encountering munitions of war, explosive materials, ionizing radiation or contamination by radio-activity, except as may be attributable to the contractor's use of such munitions, explosives, radiation or radio- activity. vi) Natural catastrophes such as earthquake, tsunami, volcanic activity, hurricane or typhoon, flood, fire, cyclones etc. vii) Epidemic, pandemic etc.
8.2	The following events are explicitly excluded from Force Majeure and are solely the responsibilities of the non-performing party: a) any strike, work-to-rule action, go-slow or similar labour difficulty (b) late delivery of equipment or material (unless caused by Force Majeure event) and (c) economic hardship.
8.3	If either party is prevented, hindered or delayed from or in performing any of its obligations under the Contract by an event of Force Majeure, then it shall notify the other in writing of the occurrence of such event and the circumstances thereof within 15 (fifteen) days after the occurrence of such event.
8.4	The party who has given such notice shall be excused from the performance or punctual performance of its obligations under the Contract for so long as the relevant event of Force Majeure continues and to the extent that such party's performance is prevented, hindered or delayed. The Time for Completion shall be extended by a period of time equal to period of delay caused due to such Force Majeure event.
8.5	Delay or non-performance by either party hereto caused by the occurrence of any event of Force Majeure shall not i) Constitute a default or breach of the Contract. ii) Give rise to any claim for damages or additional cost expense occasioned thereby, if and to the extent that such delay or non-performance is caused by the occurrence of an event of Force Majeure.



BP 200102C

BHARAT HEAVY ELECTRICALS LIMITED, BHOPAL GENERAL TERMS AND CONDITIONS OF ENQUIRY

8.6	BHEL at its discretion may consider short closure of contract after 1 year of imposition of Force Majeure in line with extant guidelines. In any case, Supplier/Vendor cannot consider deemed short-closure after 1 year of imposition of Force Majeure
9	Penalty for Late Delivery
9.1.1	Unless covered under Force Majeure conditions aforesaid, Penalty for late delivery shall be 0.5% of the undelivered portion per week of delay or part thereof, subject to a maximum of 10% of the undelivered order value owing to delayed delivery. Total undelivered order value above shall be item wise, lot wise order value of PO. Any deviation from above, which is based on specific requirement/LD clause, shall be specified in particular tender /Special terms and condition (STC) /Additional terms and conditions (ATC) and same shall have overriding effect on anything mentioned in instant GTC. Imposition, recovery or settlement of this penalty shall not adversely affect BHEL's right to performance, compensation and termination of the order.
9.1.2	However, in case of Capital Machine / BOP (Balance of plant) where staggered deliveries may be applicable, the penalty will be levied on total order value. Any deviation based on specific requirement shall be specified separately in the NIT/STC/ATC. In case of Capital items /Balance of plant (BOP) item where services of installation /erecting & commissioning /supervision are desired with supply (Milestone delivery terms), the LD clause will be separately mentioned in particular tender /Special terms and condition (STC) /Additional terms and conditions (ATC)
9.1.3	In case of any amendment / revision, the penalty shall be linked to the amended / revised PO.
9.1.4	Any loading on penalty clause shall be to the extent to which it is not agreed to by the bidder (at offered value)
9.2	In case the contractually agreed delivery date falls on a holiday in BHEL Bhopal, the next working day shall be taken as contractual delivery date for compliance and applicability of LD / penalty.
9.3	In case of any recovery for delayed performance, the applicable GST shall also be recoverable from bidders.
10	Indian Agents and Agency commission
10.1	BHEL prefers to deal directly with Foreign bidder, wherever required, for procurement of Goods. However, if the Foreign Principal desires to avail services of an Indian Agent, then the Principal should ensure compliance to "regulatory guidelines" which will require submission of an agency agreement.
10.2	The CFR / CIF price quoted will be deemed to be inclusive of Indian Agency commission. Agency commission as disclosed by the bidder in his quoted CFR / CIF price will be paid in Indian Rupees on receipt & acceptance of Materials or it's installation at destination, as the case may be. The lower of the 'TT buying rate prevailing on the date of technical bid opening or price bid opening shall be considered for computation of Agency commission.
10.3	In a tender either the Indian Agent on behalf of Principal / OEM or the Principal / OEM itself can bid, but both cannot bid simultaneously for same item / product in the same Tender. In case bids are received from both the Principal / OEM and the agent, bid received from the agent will be ignored.
10.4	If an agent submits Bid on behalf of the Principal / OEM, the same agent shall not submit bid on behalf of another Principal / OEM in the Tender, for the same Item / Product.
11	Documentation:
11.1	Indigenous Purchase Irrespective of the value of the invoice amount, the bidder / vendor should mandatorily upload the despatch & invoice details on BHEL SUVIDHA portal at https://savidha.bhel.in/savidha/ or https://bpl.bhel.com/mm/ prior to despatch. Bidder shall arrange to send to the consignee following documents immediately on despatch of the goods for GST compliance:



BP 200102C

BHARAT HEAVY ELECTRICALS LIMITED, BHOPAL GENERAL TERMS AND CONDITIONS OF ENQUIRY

- 1) Original Tax invoice in triplicate (Buyer's copy and duplicate for Transporter),
- 2) Consignee copy of LR & 2 sets each of Packing list,
- 3) Test certificate, Guarantee / Warranty certificate,
- 4) O & M manuals (where applicable)
- 5) In case of labour / mixed basis jobs, material is issued free of cost. Necessary material reconciliation is to be done and Free Issue Material Statement (FIMS) is to be submitted with each bill.
- 6) Pre-dispatch Inspection report /Third Party Inspection Certificates/MDCC certificate
- 7) Any other documents as specified in Enquiry /PO /STC/ATC of enquiry /annexure

The distribution of such documents will be specified in the Purchase order Terms and Conditions (BP 205315 for indigenous and BP205316 for Imported Purchases)

*Note: All documents as per PO checklist, along with additional documents (if any), must be uploaded on the portal. It is mandatory that tax invoices with a net amount (including taxes) exceeding ₹ 5 lakhs uploaded on the portal are digitally signed using a Class 3 Digital Signature Certificate (DSC) issued by a licensed Certifying Authority. For invoices up to ₹ 5 lakhs, (inclusive of taxes), a scanned copy may be uploaded; however, submission of hard copy is mandatory if a class 3 digitally signed tax invoice is not uploaded.

Foreign Purchase — Imports Seller shall send 1 set of following documents, in English, within 7 days of B/L date / 1 day of AWB date by courier to the Purchaser

1. Express / Original 'Clean on board' Bill of Lading / AWB.
2. One set of Commercial Invoice, packing list indicating container-wise Gross weight, Net weight, CBM volume, No. of packages with Dimensions of each package.
3. Original Certificate of Country of Origin (COO) issued by Chamber of Commerce. COO shall be as per requisite format where duty concession is available under Preferential Trade/Comprehensive Economic Partnership/Free Trade agreement. Customs tariff heading (CTH)/ Harmonized System of Nomenclature (HSN) code of material should be mentioned on invoice and COO in all such cases.
4. One set of Original Test Certificates and O&M Manual where called for.
5. Fumigation / Phyto-Sanitary Certificate wherever cargo is packed in wooden packing or packing of plant origin material is used.
6. Supplier should additionally forward 2 sets of original documents mentioned at point nos. 1 to 5 above along with Original Bill of Lading (OBL) or AWB through any international courier service/registered airmail within three (3) days of obtaining the same directly to the following:

AGM (M.S)
Regional Operations Division BHEL
14th Floor Centre-1
World Trade Centre, Cuffe Parade
Mumbai 400 005 INDIA
Email: msseabpl@bhel.in (In case of Sea freight) msair@bhel.in (In case of Air freight)

DGM (FIN- FP)
4th Floor, Administrative Bldg.
BHEL Bhopal - 462022 (India)
E-mail: fin_fp.bpl@bhel.in

- And confirm forwarding details to AGM (CMM- FE), BHEL Bhopal at mmfe.bpl@bhel.in
7. In case the Seller decides to negotiate all 3 originals of B/L / AWB along with all original documents through negotiating Bank, non-negotiable documents (NNDs) consisting of copy of B/L / AWB & documents mentioned at Sl. no. 11- B2 to B5 will be sent by e-mail to the Purchaser at his e-mail address given in the PO with one copy to be mailed at mmfe.bpl@bhel.in as well as at msseabpl@bhel.in (for Sea shipment) or msair@bhel.in (for Air shipment). Other documents, as required, will be separately indicated in the Purchase Order. Additional expenditure, if any, incurred by the Purchaser by way of detention / demurrage, resulting out of delay attributable to the Seller in providing Negotiable documents, will be recovered from the Seller.

In case any discrepancy is raised by the Bankers / BHEL with respect to the documents submitted, vendor to facilitate clearance of goods through Delivery Order.

Additionally, following requirements to be taken care of by the bidder during PO execution stage:

11.2



BP 200102C

BHARAT HEAVY ELECTRICALS LIMITED, BHOPAL

GENERAL TERMS AND CONDITIONS OF ENQUIRY

	<p>i) IEC (0588138690), (BHEL BHOPAL GSTIN: 23AAACB4146P1ZN) and email ID (mmfe.bpl@bhel.in) of BHEL Bhopal shall be clearly mentioned on B/L or AWB.</p> <p>ii) As per Uniform Customs Practice (UCP 600) for documentary credits (L/C), presentation period allowed is maximum 21 days after the date of shipment. However, for geographically closer ports where sea voyage time is less than 3-4 weeks, a shorter presentation period shall be agreed upon.</p> <p>iii) In case of CAD payment terms, Supplier shall send documents to BHEL's bank within 5 days of shipment. One set of original may be sent to any one of ROD, CMM-FE and MM, copy may be marked to the others.</p> <p>iv) For Air shipments through non-CONSOL (i.e., not through BHEL ROD's contract), Delivery Order (DO) should be given to BHEL without insisting for Bank Release Order (BRO). AWB to be drawn with BHEL Bhopal as consignee.</p> <p>v) It must be ensured that original shipping/commercial documents, if not provided to BHEL outside banking channel, should reach BHEL's bank at least 10 days prior to cargo arrival at port.</p> <p>vi) Part shipment and trans-shipment to be avoided to the extent possible especially where it is not possible to split shipping & commercial documents. Part shipment shall be strictly avoided for Air shipments.</p>
11.3	General
	<ol style="list-style-type: none"> 1. For Hazardous chemicals, the materials safety data sheet (MSDS) is to be submitted. 2. All certificates as called must be sent. BHEL may test any goods supplied and their decision is final irrespective of supplier's certificates. If test certificate and guarantee certificate are not received along with the document and stipulated in these specifications, BHEL reserves the right to get the material tested and recover the expenses from the supplier without awaiting supplier's confirmation 3. Goods shall be properly packed to avoid transit damage. Suitable markings shall be provided to identify the goods with that of the PO No. and the consignee details. 4. Goods shall be consigned to AGM (CRX), BHEL, Piplani, Bhopal - 462022, India, unless otherwise specified in the PO.
12	Pricing Terms
12.1	Prices once quoted shall remain firm within the validity or any extension thereof for placement of order, till complete execution of the order, without any escalation/increase for any reason, whatsoever, unless specifically provided for in the Enquiry & PO. In case of foreign bidders, the quoted price shall be taken as inclusive of Third-Party Inspection and testing charges as called for in the NIT.
13	Price Validity:
13.1	Unless stated otherwise in the enquiry, offer shall be valid for a period of 90 days from the date of Techno-commercial (Part-I) bid opening date.
14	Taxes & Duties - Indigenous Purchase
14.1	Bidder to ensure timely remittance of SGST, CGST, IGST as applicable in time as per law. BHEL BHOPAL GSTIN: 23AAACB4146P1ZN
14.2	Bidder to ensure compliance to filing of monthly GST sales return including BHELs supplies by 10 th of next calendar month in the online GST portal wherever applicable.
14.3	Bidders to declare filing of timely returns and GST remittance/likely remittance /ITC adjustment along with invoice.
14.4	Bidder to submit invoices compliant with GST invoice Rules
14.5	Bidders to comply with all statutory provisions as may be applicable at the time of despatch/sale. Any additional financial liability to BHEL on account of non-compliance by bidders shall be borne by them and shall be adjusted / recovered from the bidders. BHEL reserves the right to review the existing offers / contracts for any revision in terms, which may arise due to change in any statutory provisions to ensure that the benefit accrues to BHEL.
14.6	Bidder to ensure TAX INVOICE submission along with consignment
14.7	In respect of cases where the liability to discharge GST is on BHEL under reverse charge mechanism, bidders have to ensure timely submission of invoices and delivery of material / services to BHEL, so that there is no mismatch on both activities. In case there is any additional financial liability on BHEL on account of default on the part of the bidder on submission or delivery of material / services the same shall be passed on to them.



BP 200102C

**BHARAT HEAVY ELECTRICALS LIMITED, BHOPAL
GENERAL TERMS AND CONDITIONS OF ENQUIRY**

14.8	Vendors who fall under the E-Invoice regulations shall issue e-invoice in line with Rule 48(4) of CGST Rules read along with latest extant rules, failing which GST amount will not be reimbursed to the vendor.
14.9	In respect of free issue material by BHEL, bidders have to return the processed material within the time line as per the provisions of GST. In case of any additional tax liability on BHEL on account of non-compliance by the bidder, the additional financial implications on BHEL shall be passed on to the bidder
14.10	Bidders to provide the applicable HSN / SAC codes as called for in the enquiry
14.11	As per provisions of section 171 of the CGST Act 2017, bidders to pass on the anti-profiteering benefits accruing to them under GST regime to BHEL
14.12	With reference to section 51 of CGST act 2017 read with notification no 50/2018 – Central tax dated 13.09.2018; BHEL will be liable to deduct TDS under GST with effect from 01.10.2018. Deduction shall be made @ 2% (1% CGST + 1% SGST) or 2% IGST (as applicable) of the payment made or the amount credited. Bidder to generate & submit invoices as per above. The amount of TDS shall be deposited to the Government account and BHEL shall issue TDS certificate to deductees, TDS deposited in the Government account will be reflected in the electronic cash ledger of the deductee who will be able to use the same for payment of tax or any other amount. Deduction of TCS along with additional TDS will be as per prevailing Government guidelines.
15.	Taxes & Duties - Foreign Purchase — Imports
15.1	The offered prices shall be inclusive of all the Taxes and duties as applicable in the country of bidder / country of dispatch for the quoted CFR / CIF price.
16	Payment Terms-
16.1	Indigenous: 100% payment in 90 days of receipt (45 days for Micro & Small and 60 days for Medium enterprises as registered in Udyam certificate as per relevant MSME act in force) and subject to acceptance of material and relevant documents at BHEL. In case of despatch of material to site directly, site certification for receipt of materials is required unless otherwise provided for in the PO. Any deviation from the above payment terms, if accepted (by BHEL), shall be loaded @ "Repo Rate + 4%" for the purpose of bid evaluation.
16.2	Foreign: 100% against irrevocable, unconfirmed LC, payable within 90 days of the Bill of Lading (B/L) date or Payment terms of CAD payable on 90 th day of B/L / AWB. In case BHEL considers any deviation in payment terms i.e. early payment based on bidder's request, then bids shall be evaluated with loading @ "Repo Rate + 4%", for the credit period short of 90 days. The LC shall be established 2 months prior to shipment date, valid for period of 90 days, unless agreed otherwise. Documents to be submitted as per UCP600 and should reach BHEL/ BHEL's bank at least 7 days prior to vessel arrival.
16.3	Staggered Payment terms in case of Capital items /Balance of plant (BOP) item where services of installation /erecting & commissioning /supervision are desired with supply of items /goods will be separately mentioned in particular tender remarks /Special terms & condition /Additional terms and condition
16.4	Foreign bidders to submit declaration of Permanent Establishment and Business Connection (PEBC) for remittances purpose. Declaration to be submitted in formats either in Annexure A or B whichever is applicable as per their transaction entered into with BHEL. In the absence of certificates from the bidder, withholding tax at applicable rates along with surcharge and cess will be recovered at the time of remittance to the bidder.
16.5	Foreign bidders to submit Tax Residency Certificate (TRC) & Form 10F (for obtaining DTAA benefits) as per Annexure C in respect of services. The TRC is to be issued by the authorities of the government of bidder's country. If the informative part of the format (other than residency) is not furnished by the authorities the same may be furnished by the bidder as a declaration.
16.6	BHEL Bhopal is registered with (TReDS) platform. MSME bidders are requested to get registered with (TReDS) platform to avail the facility as per the GOI guidelines.
17	Inspection of Goods
17.1	The Bidder shall give adequate notice, of 1 week or as mutually agreed period, in writing to the Purchaser (in case Customer inspection is involved) or BHEL appointed TPIA about the date and place at which the goods will be ready for inspection/ testing, as provided for in the contract.



BP 200102C

**BHARAT HEAVY ELECTRICALS LIMITED, BHOPAL
GENERAL TERMS AND CONDITIONS OF ENQUIRY**

17.2	<p>Purchaser or his authorized representative shall be entitled to carry out inspection of material and workmanship/Surveillance Audit at Bidder's premises or at his sub-contractor's premises at all reasonable times during execution of contract; Such inspection, examination and testing, if made, shall not absolve the Bidder from his obligations under the contract.</p> <p>Wherever required, BHEL may carry out testing at BHEL's testing Lab and in case of any rejection during such testing, replacement / rectification, as required, will have to be done by Supplier.</p> <p>If BHEL carries out any rectification of such rejected material, such cost will be recovered from Supplier's Bills.</p> <p>In case of Customer inspection as Supplier's Works, inspection clearance to be obtained from Customer and submitted to BHEL.</p>
17.3	<p>BHEL's representative from unit or Corporate Quality (CQ) is authorised to carry out audits along with TPIA at bidder's works before clearing the items for despatch.</p>
17.4	<p>All costs related to inspections and re-inspections shall be borne by the Bidder. In case of inspection by BHEL and / or BHEL's customer, the cost of to & fro passage and Boarding & Lodging shall be borne by the Purchaser / Customer, unless otherwise specifically agreed. In case of foreign bidders, the cost of third-party inspection, where called for, shall be deemed to be included in the quoted price. Bidder shall be responsible to provide assistance such as labour, materials, electricity, fuels, stores, apparatus, instruments at his cost, as may be required and as may be reasonably demanded to carry out such tests effectively.</p>
17.5	<p>REJECTION: If any goods are rejected, BHEL shall be at liberty to take action as per following:</p> <p>a) Allow the supplier, wherever mutually agreed, to rectify the rejected goods at BHEL's works within reasonable time as fixed by BHEL.</p> <p style="text-align: center;">Or</p> <p>b) Allow the supplier to make free replacement within a specified period. Rejected goods can be lifted by the supplier thereafter.</p> <p style="text-align: center;">Or</p> <p>c) In case payment has been done, allow supplier to refund equivalent value of rejected material by NEFT / RTGS or furnish Bank Guarantee for same amount before lifting the rejected goods. Fresh replacement shall be regulated as per terms and condition of the original Purchase Order. In case payment has not been done, at instructions from BHEL, supplier has to rectify the rejected goods at supplier's works within reasonable time as fixed by BHEL.</p> <p style="text-align: center;">Or</p> <p>d) Terminate the contract either in part or in whole at the discretion of BHEL and invoke Breach of Contract clause, if any, from the supplier.</p> <p style="text-align: center;">Or</p> <p>e) Any goods rejected by BHEL must be removed by the supplier after making payment through NEFT / RTGS within 30 days after receipt of the intimation of rejection. If bidder fails to lift or allow despatch of rejected material at his cost within 90 days from the intimation of rejection, his claim on rejected material shall cease.</p> <p style="text-align: center;">Or</p> <p>f) In exceptional cases, allow the supplier for one-time replacement of defective items (quantity) within reasonable time.</p>
18	Guarantee / Warranty and corresponding Repairs / Replacement of Goods



BP 200102C

**BHARAT HEAVY ELECTRICALS LIMITED, BHOPAL
GENERAL TERMS AND CONDITIONS OF ENQUIRY**

18.1	<p>Manufacturer's works test/inspection certificates shall be furnished along with the guarantee that material conforms strictly to the specification for general & special conditions as laid down in the purchase order. Goods shall comply with the specifications for material, workmanship and performance. The warranty shall be for a period of 12 months from the date of receipt. If the delivery is found non-compliant during the warranty period, leading to rejection, the Bidder shall arrange free replacement / repair of goods, within one month from the date of intimation or any mutually agreed period. The rejected goods shall be taken away by the Bidder at his cost and replaced on Delivered Duty Paid (DDP) (FOR - BHEL Stores/ designated destination basis) within such period. In the event of the Bidder's failure to comply, Purchaser may take action as appropriate, including Repair / Replenish rejected goods & disposal of rejections, at the risk & cost of the Bidder.</p> <p>In case the defects attributable to Bidder are detected during processing of the goods at purchaser's / his subcontractor's works, the Bidder shall be responsible for free replacement/ repair of the goods as required by the purchaser.</p>
19	<p>NOTE: Deviations (Commercial as well as Technical) from the tender specifications and conditions are generally not acceptable. However, deviation if any, shall be brought out clearly with proper justification in the offer. The deviation, if considered by BHEL shall be loaded for comparison, while evaluating the offer. If a bidder unconditionally withdraws any deviation before price bid opening, the same shall not be loaded. Loading criteria in respect of major commercial conditions where deviations if any are accepted shall be as per clause No.19.</p>
19.1	Evaluation and Loading Criteria:
19.1.1	<p>The evaluation currency for this tender shall be INR.</p> <p>Evaluation of the tender shall be on the basis of delivered cost, i.e. 'Total Cost to BHEL/Landed cost to BHEL' w.r.t the technical scope and commercial conditions finalized after techno-commercial clarifications (after considering, inter alia, Customs Duty and GST / Other taxes as applicable). Exchange rate (TT selling rate of State Bank of India) applicable on the date of Part-I bid opening shall be considered for evaluation of foreign bids. If the relevant day happens to be a bank holiday in India, then the FOREX rate as on the previous bank working day shall be taken for evaluation.</p> <p>Foreign suppliers shall ensure that the benefits as applicable under Comprehensive Economic Partnership Agreement (CEPA) with Government of India are disclosed in the bid & relevant documents such as Certificate of Country of Origin, issued by the appropriate authority in the country of Export, is provided by the bidder along with dispatch documents.</p> <p>Bids shall be evaluated with such applicable benefits. In the event of Bidder failing to provide appropriate documents for Purchaser to avail disclosed concessional duty benefits in India, financial loss, so incurred, will be to the Bidder's account.</p>
19.1.2	<p>Common Loading factors (in case of deviation quoted by bidders)</p> <p>INDIGENOUS</p> <ol style="list-style-type: none">1) Deviation quoted in delivery terms in EX works against FOR destination: In case BHEL accepts the EX-Works prices, such offers will be suitably loaded with actual freight charges as per BHEL freight rate contract.2) Loading (if any) in case of deviation in delivery period in delivery non- sensitive contracts will be declared separately in STC/ATC of particular tenders. <p>IMPORTS</p> <ol style="list-style-type: none">1) Offer received on FOB/FCA basis may be considered on an exceptional basis. BHEL will load freight, marine insurance & shipping line port handling charges etc. to work out landed cost at Sea Port.2) Import duty, Taxes and duties as applicable on the date of Part-I bid opening. <p>COMMON LOADING FOR IMPORTS & INDIGENOUS that will be added for arriving the "Total Cost to BHEL"</p> <p>A. Loading on Deviated Penalty clause (LD) as per clause 9.1.14 of GTC</p> <p>B. Loading for payment terms as per clause 16.1 of GTC</p>
20	Variation of orders
20.1	No variation to the Purchase order is permitted unless authorised in writing and signed by or on behalf of purchase executive, BHEL Bhopal.
21	Sub-contract



BP 200102C

BHARAT HEAVY ELECTRICALS LIMITED, BHOPAL GENERAL TERMS AND CONDITIONS OF ENQUIRY

21.1	BHEL's order or part there off, if further to be subcontracted in exceptional circumstances the details of subcontracting and to whom to be subcontracted shall be furnished to BHEL and written permission shall be obtained from BHEL. However, it shall not absolve the supplier of the responsibility of fulfilling BHEL order requirements.
22	Recovery / deductions of amount from supplier
22.1	a Any amount on account of recovery from consignor / supplier under any condition shall be liable to be adjusted against any amount payable to the consignor/supplier against bills. b For any deficiency in supplies where deduction is involved, an amount as decided by BHEL, shall be deducted from supplier's bills. c If it is not possible to recover the dues available from the same contract or dues are insufficient to meet the recoverable amount, balance amount shall be recovered from any money(s) payable to Supplier/Vendor under any contract with other Units of BHEL including recovery from security deposits or any other deposit available in the form of security instruments of any kind against Security deposit or EMD.
23	Safety clause for purchase orders
23.1	The bidders shall maintain and ensure sufficient safety measures as required for inspections and test like HV test. Pneumatic test, Hydraulic test Spring test, Bend test, Material handling and safe working environment etc. to enable Inspection Agency for performing inspection. The bidder shall ensure that all the safety precautions specified in factories Act 1948 chapter-IV Section-21 to 41 are complied with respect to equipment's to be inspected. If any test equipment is found not complying with proper safety requirement, then the inspection agency may withhold inspection, till such time the desired safety requirements are met.
24	Non-Disclosure Agreement
24.1	All Drawing and technical documents relating to the product or it's manufacture submitted by one party to the other, prior or subsequent to the formation of contract, shall remain property of the submitting party. Drawing, technical documents or other technical information received by one party, shall not without the consent of the other party, be used for any other purpose than that, for which they were provided. Such technical information shall not without the consent of the submitting party, otherwise be used or copied, reproduced, transmitted or communicated to a third party. Patterns supplied by BHEL will remain BHEL's property which shall be returned by the bidder on demand to BHEL. Bidder shall in no way share or use such intellectual property of BHEL to promote his own business with others. <u>BHEL reserves the right to claim damages from the bidder, or take appropriate penal action as deemed fit against the bidder, for any infringement of the provisions contained herein.</u>
	DRAWINGS, PATTERNS & TOOLS: All drawings, patterns & tools supplied by BHEL or made at BHEL's expense are BHEL's property. These cannot be used or referred to any other party and must only be used in the execution of BHEL's orders. These should be preserved at the supplier's cost for a period of not less than 5 years. Patterns & tools should be returned to BHEL within 90 days of issue of the same.
25	Settlement of Disputes & Arbitration
25.1	25.1 SETTLEMENT OF DISPUTE If any dispute or difference of any kind whatsoever shall arise between BHEL and the Supplier/Vendor, arising out of the contract for the performance of the work whether during the progress of contract termination, abandonment or breach of the contract, it shall in the first place referred to Designated Engineer for amicable resolution by the parties. Designated Engineer (to be nominated by BHEL for settlement of disputes arising out of the contract) who within 60 days after being requested shall give written notice of his decision to the contractor. Save as hereinafter provided, such decision in respect of every matter so referred shall forthwith be given effect to by the Supplier/Vendor who shall proceed with the work with all due diligence, whether he or BHEL desires to resolve the dispute as hereinafter provided or not. If after the Designated Engineer has given written notice of this decision to the party and no intention to pursue the dispute has been communicated to him by the affected party within 30 days from the receipt of such notice, the said decision shall become final and binding on the parties. In the event the Supplier/Vendor being dissatisfied with any such decision or if amicable settlement cannot be reached then all such disputed issues shall be resolved through conciliation in terms of the BHEL Conciliation Scheme 2018 as per Clause 25.2



BP 200102C

BHARAT HEAVY ELECTRICALS LIMITED, BHOPAL GENERAL TERMS AND CONDITIONS OF ENQUIRY

25.2	CONCILIATION Any dispute, difference or controversy of whatever nature howsoever arising under or out of or in relation to this Agreement (including its interpretation) between the Parties, and so notified in writing by either Party to the other Party (the "Dispute") shall, in the first instance, be attempted to be resolved amicably in accordance with the conciliation procedure as per BHEL Conciliation Scheme 2018. The proceedings of Conciliation shall broadly be governed by Part-III of the Arbitration and Conciliation Act 1996 or any statutory modification thereof and as provided in - "Procedure for conduct of conciliation proceedings" (as available in www.bhel.in)
25.3	ARBITRATION
25.3.1	Except as provided elsewhere in this Contract, in case Parties are unable to reach amicable settlement (whether by Conciliation to be conducted as provided in Clause 25.2 herein above or otherwise) in respect of any dispute or difference; arising out of the formation, breach, termination, validity or execution of the Contract; or, the respective rights and liabilities of the Parties; or, in relation to interpretation of any provision of the Contract; or, in any manner touching upon the Contract (hereinafter referred to as the 'Dispute'), then, either Party may, refer the disputes to <i>sole arbitration of an arbitrator appointed by Head of the BHEL Unit/Region/Division issuing the Contract.</i>
25.3.2	A party willing to commence arbitration proceeding shall invoke Arbitration Clause by giving notice to the other party in terms of section 21 of the Arbitration & Conciliation Act, 1996(hereinafter referred to as the 'Notice') before referring the matter to <i>Arbitration</i> . The Notice shall be addressed to the Head of Unit, HEP Bhopal, BHEL, executing the Contract and shall contain the particulars of all claims to be referred to arbitration with sufficient detail and shall also indicate the monetary amount of such claim including interest, if any.
25.3.3	After expiry of 30 days from the date of receipt of aforesaid notice, the party invoking the Arbitration shall submit that dispute to the <i>Arbitrator</i> and that dispute shall be adjudicated in accordance with <i>Arbitration and conciliation Act 1996</i> . The matter shall be adjudicated by a Sole Arbitrator who shall necessarily be a Retd Judge having considerable experience in commercial matters to be appointed/nominated by the <i>respective Head of unit</i> . The cost/expenses pertaining to the said Arbitration shall also be governed in accordance with the <i>Arbitration and conciliation Act 1996</i> . The decision of the <i>respective Head of Unit of BHEL</i> for reference of dispute to a specific <i>Arbitrator</i> for adjudication of that dispute shall be final and binding on both the parties and shall not be subject to any change thereafter. The <i>Arbitrator</i> -once <i>appointed</i> at the time of invocation of dispute shall remain unchanged.
25.3.4	The fee and expenses shall be borne by the parties as per the <i>Arbitration and conciliation Act 1996</i> .
25.3.5	The Arbitration proceedings shall be in English language and the seat and venue of Arbitration shall be Bhopal in the State of Madhya Pradesh,
25.3.6	Subject to the above, the provisions of Arbitration & Conciliation Act 1996 and any amendment thereof shall be applicable. All matters relating to this Contract and arising out of invocation of Arbitration clause are subject to the exclusive jurisdiction of the Court(s) situated at Bhopal in the State of Madhya Pradesh,
25.3.7	Notwithstanding any reference to the Designated Engineer or Conciliation or Arbitration herein, a. the parties shall continue to perform their respective obligations under the Contract unless they otherwise agree. Settlement of Dispute clause cannot be invoked by the Contractor, if the Contract has been mutually closed or 'No Demand Certificate' has been furnished by the Contractor or any Settlement Agreement has been signed between the Employer and the Contractor.
25.3.8	The Mechanism of resolution of disputes through arbitration shall be available only in the cases where the value of the dispute is less than Rs. 10 Crores.
25.3.9	In case the disputed amount (Claim, Counter claim including interest is Rs. 10 crores and above, the parties shall be within their rights to take recourse to remedies other than Arbitration, as may be available to them under the applicable laws after prior intimation to the other party. Subject to the aforesaid conditions, provisions of the Arbitration and Conciliation Act, 1996 and any statutory modifications or re-enactment thereof as amended from time to time, shall apply to the arbitration proceedings under this clause.
25.3.10	In case, multiple arbitrations are invoked (whether sub-judice or arbitral award passed) by any party to under this contract, then the cumulative value of claims (including interest claimed or awarded) in all such arbitrations shall be taken in account while arriving at the total claim in dispute for the subject contract for



BP 200102C

BHARAT HEAVY ELECTRICALS LIMITED, BHOPAL GENERAL TERMS AND CONDITIONS OF ENQUIRY

	the purpose of clause 25.3.8 and 25.3.9 . Disputes having cumulative value of less than 10 crores shall be resolved through arbitration and any additional dispute shall be adjudicated by the court of competent jurisdiction.
25.3.11	<p>In case of Contract with Public Sector Enterprise (PSE) or a Government Department, the following shall be applicable:</p> <p>In the event of any dispute or difference relating to the interpretation and application of the provisions of commercial contract(s) between Central Public Sector Enterprises (CPSEs)/ Port Trusts inter se and also between CPSEs and Government Departments/Organizations (excluding disputes concerning Railways, Income Tax, Customs & Excise Departments), such dispute or difference shall be taken up by either party for resolution through AMRCD (Administrative Mechanism for Resolution of CPSEs Disputes) as mentioned in DPE OM No. 05/0003/2019-FTS- 10937 dated 14-12-2022 as amended from time to time</p>
27	RIGHT OF REJECTION /NON- PLACEMENT OF PO: BHEL reserves the right to accept the offers in part or in full, or cancel the Tender enquiry without assigning any reason.
28	Performance Bank Guarantee (PBG)/ Security Deposit (SD):
28.1	<p>Wherever Security Deposit (covering contract performance) is called for in the Tender /NIT, the Performance Bank Guarantee (PBG) or Security Deposit (SD), hereafter referred as performance security is to be submitted by the successful bidder awarded the contract. Performance security is to be submitted by the date specified in the contract. Modes of deposit:</p> <p>a) Performance security may be furnished in the following forms:</p> <p>(i) Local cheques of Scheduled Banks (subject to realization)/ Pay Order/ Demand Draft/ Electronic Fund Transfer in favour of BHEL.</p> <p>(ii) Bank Guarantee from Scheduled Banks / Public Financial Institutions as defined in the Companies Act. The Bank Guarantee format should have the approval of BHEL.</p> <p>(iii) Fixed Deposit Receipt issued by Scheduled Banks / Public Financial Institutions as defined in the Companies Act (FDR should be in the name of the Contractor, a/c BHEL).</p> <p>(iv) Securities available from Indian Post offices such as National Savings Certificates, Kisan Vikas Patras etc. (held in the name of Contractor furnishing the security and duly endorsed/ hypothecated/ pledged, as applicable, in favour of BHEL).</p> <p>(v) Insurance Surety Bond.</p> <p>(Note: BHEL will not be liable or responsible in any manner for the collection of interest or renewal of the documents or in any other matter connected therewith)</p> <p>b) In case of GTE tenders, the performance security should be in the same currency as the contract and must conform to Uniform Rules for Demand Guarantees (URDG 758) - an international convention regulating international securities. a) Performance Security is to be furnished by a specified date (generally 14(fourteen) days after notification of the award) and it should remain valid for a period of 60 (sixty) days beyond the date of completion of all contractual obligations of the supplier, including warranty obligations.</p> <p>Forfeiture of Performance Security: The performance security will be forfeited and credited to BHEL's account in the event of a breach of contract by the supplier. PS shall be refunded to the contractor without interest, after he duly performs and completes the contract in all respects but not later than 60 (sixty) days of completion of all such obligations including the warranty under the contract. The Performance Security shall not carry any interest.</p>
28.2	Composite 'Contract Performance Bank Guarantee' of matching value/ validity, where both Security Deposit and Performance Bank Guarantee are required, shall not be construed as deviation.
28.3	Wherever the contract is for supply of Goods processed on labour basis/mixed basis from BHEL supplied materials, the materials shall be issued against a suitable Bank guarantee as specified in the particular Enquiry/STC/ATC/Annexures.
28.4	Wherever PBG (covering equipment / system / work performance guarantee) is called for in the Notice Inviting Tender (NIT) deviation shall not be accepted
28.5	Bank Guarantee wherever called for, shall be in the BHEL prescribed format. In case the order is to be placed in foreign currency, the BG must also be in Foreign currency, so specified by the Purchaser



BP 200102C

**BHARAT HEAVY ELECTRICALS LIMITED, BHOPAL
GENERAL TERMS AND CONDITIONS OF ENQUIRY**

28.6	Wherever Security Deposit (covering contract performance) is called for in the NIT, deviation shall not be accepted.
28.7	Bidder agrees to submit performance security required for execution of the contract within the time period mentioned. In case of delay in submission of performance security, enhanced performance security which would include interest "Repo Rate + 4%" for the delayed period, shall be submitted by the bidder. Further, if performance security is not submitted till such time the first bill becomes due, the amount of performance security due shall be recovered as per terms defined in NIT / contract, from the bills along with due interest
29	Benefits earmarked for Purchase from Micro & Small Enterprises (MSEs) – All benefits as per Government of India guidelines shall be given to eligible bidders. MSE bidders as defined by the MSMED Act as amended from time to time can avail the intended benefits only if they submit along with the offer, self-attested copies of relevant document, Udyam Registration as applicable stipulated in the MSMED Act or its rules/ regulations as amended from time to time and /or by the buyer. Non-submission of such documents as stipulated hereinbefore will lead to consideration of their bids at par with other bidders. No benefit shall be applicable for the concerned for the tender enquiry, if any deficiency in the above required documents is not submitted before the price bid opening. If the tender is to be submitted through e-procurement portal, then the above required documents are to be uploaded on the portal. This provision for MSE will apply subject to the condition that the participating MSE meets the tender requirements. In case of any change in the MSE status of the bidder, it shall be the responsibility of the bidder to notify the change as a part of the bid document. If at a later date it comes to the knowledge of BHEL, that the change in the status has not been intimated by the bidder and the order is obtained under the premise of an MSE then BHEL may reject the bid or, as the case may be, cancel the order and take necessary steps for suspension of the business dealing against the bidder as per the extant guidelines for suspension of business dealings with suppliers/ contractors of BHEL. Note: MSME benefits shall not be given to traders, Dealers or authorised agents. It may however be noted that MSE guidelines as on date (Date of Technical Bid Opening Part-1) shall prevail. As per the OM No. F. No. 1(2)(1)/2016-MA Dtd. 09.02.2017 issued from the Office of Development Commissioner (Micro, Small & Medium Enterprises), "Traders and agents should not be allowed to avail the benefits extended under the PP Policy". In view of this, it is clarified that benefits of MSE (such as EMD Waiver, Tender fee exemption, Price preference, Payment preference etc.) will be given only to those MSE Vendors who are manufacturers of offered items against the NIT. No MSE benefits shall be provided to Agents / Stockists / Dealers / Traders etc. for the items offered but not manufactured by themselves.
29.1	MSEs shall be given tender documents free of cost and shall be exempted from payment of EMD. Tender documents shall be issued free of cost & no EMD wherever called for will be insisted upon. MSE bidders shall submit along with bid relevant documents w.r.t. their respective MSE status as per extant norms. Date to be reckoned for determining the deemed validity will be the last date of Technical bid submission. Non-submission of such document will lead to consideration of their bid, at par with other bidders and MSE status of such bidders shall be shifted to Non- MSE supplier till the supplier submit these documents.
29.2	In tender, participating MSEs quoting price within price band of L1+15% shall also be allowed to supply a portion of requirement by bringing down their price to L1 price in a situation where L1 price is from someone other than an MSE and such MSE shall be allowed to supply up to at least 25% of total tendered value. In case of more than one such MSE, the supply shall be shared proportionately. A quantum of 6.25% (25% out of target of 25%), so earmarked, will be reserved for MSE's owned by SC / ST entrepreneurs who submit their bid with relevant documents provided that in event of failure of such MSE(s) to participate in tender process or meet tender requirements and L1 price, 6.25% sub-target for procurement earmarked for MSE(s) owned by SC or ST entrepreneurs shall be met from other MSE(s). A quantum of minimum of 3% reservation within the above mentioned 25% reservation, so earmarked, will be reserved for MSE's owned by women entrepreneurs who submit their bid with relevant documents provided that in event of failure of such MSE(s) to participate in tender process or meet tender requirements and L1 price, 3% sub-target for procurement earmarked for MSE(s) owned by women entrepreneurs shall be met from other MSE(s).



BP 200102C

BHARAT HEAVY ELECTRICALS LIMITED, BHOPAL GENERAL TERMS AND CONDITIONS OF ENQUIRY

	In case of indivisible tender, the full quantity shall be awarded to L1.															
29.3	If an enterprise falling under MSE category as defined in the MSMED Act 2006, graduates to a higher category from its original category or beyond the purview of the Act, it shall continue to avail all non-tax benefits of its original category notified by the Ministry of Micro, Small and Medium Enterprise for a period of three years from the date of such graduation to the higher category.															
29.4	<p>MSE bidders as defined by the MSMED Act as amended from time to time can avail the intended benefits only if they submit, self-attested copies of Udyam Registration certificate, along with the offer. No benefits shall be applicable for the enquiry if any deficiency in the above required documents are not submitted before price bid opening. If the tender is to be submitted through e-procurement portal, then the above required self-attested documents are to be uploaded on the portal.</p> <p>No benefits shall be applicable for this enquiry if any deficiency in the above required documents are not submitted before price bid opening. If the tender is to be submitted through e-procurement portal, then the above required self-attested documents are to be uploaded on the portal.</p> <p>The deemed validity will be assessed on the date of bid opening (Part 1 in case of two-part bid). Non-submission of such documents as stipulated hereinbefore will lead to consideration of their bids at par with other bidders. No benefit shall be applicable for the concerned for the tender enquiry, if any deficiency in the above required documents is not submitted before the price bid opening. This provision for MSE will apply subject to the condition that the participating MSE meets the tender requirements.</p> <p>In case of any change in the MSE status of the bidder, it shall be the responsibility of the bidder to notify the change as a part of the bid document. If at a later date it comes to the knowledge of BHEL, that the change in the status has not been intimated by the bidder and the order is obtained under the premise of an MSE then BHEL may reject the bid or, as the case may be, cancel the order and take necessary steps for suspension of the business dealing against the bidder as per the extant guidelines for suspension of business dealings with suppliers/ contractors of BHEL.</p> <p>In case if all the items being procured under the enquiry fall under category of reserved items as defined in "Public Procurement Policy for Micro and Small Enterprises (MSEs) Order, 2012" and if any of the MSE bidder(s) is techno commercially qualified then the price bids of only MSE bidders shall be opened. If no MSE bidder is techno-commercially qualified, then price bids of all techno-commercially qualified bidders shall be opened.</p>															
30	<p>Integrity Pact (IP) — Independent external monitors (IEM)</p> <p>For tenders in which integrity pact is applicable, following points stand valid:</p>															
30.1	<p>IP is a tool to ensure that activities and transactions between the company and its bidders/contractors are handled in a fair, transparent and corruption free manner. A panel of Independent External Monitors (IEMs) have been appointed to oversee implementation of IP in BHEL.</p> <p>The IP as enclosed with the tender is to be submitted (duly signed by authorized signatory who signs in the offer) along with techno commercial bid. Only those bidders who have entered into such an IP with BHEL would be competent to participate in the bidding. In other words, entering into this pact would be a preliminary qualification.</p> <p>Name: ----- } ----- Address: ----- } ----- As indicated in NIT / enquiry E-mail: ----- --</p>															
30.2	<p>Please refer section 8 of the IP for roles and responsibilities of IEMs. In case of any complaint arising out of tendering process, the matter may be referred to the IEM mentioned in the tender.</p> <p>NOTE: No routine correspondence shall be addressed to the IEM (phone / post/e-mail) regarding the clarifications, time extensions or any other administrative queries, etc. on the tender issued. All such clarifications/ issues shall be addressed directly to the tender issuing (procurement) department.</p> <p>For all clarifications/ issues related to the tender, please contact:</p> <table border="1"> <thead> <tr> <th></th> <th>(1)</th> <th>(2)</th> </tr> </thead> <tbody> <tr> <td>Name</td> <td></td> <td></td> </tr> <tr> <td>Landline No.</td> <td></td> <td></td> </tr> <tr> <td>Mobile No.</td> <td></td> <td></td> </tr> <tr> <td>Email</td> <td></td> <td></td> </tr> </tbody> </table>		(1)	(2)	Name			Landline No.			Mobile No.			Email		
	(1)	(2)														
Name																
Landline No.																
Mobile No.																
Email																



BP 200102C

BHARAT HEAVY ELECTRICALS LIMITED, BHOPAL GENERAL TERMS AND CONDITIONS OF ENQUIRY

		Dept.		
		Address		
		Fax		
31	Fraud Prevention Policy : The Bidder along with its associate/ collaborators/ sub-contractors/ sub-bidders/ consultants/ service providers shall strictly adhere to BHEL Fraud Prevention Policy displayed on BHEL website www.bhel.com and shall immediately bring to the notice of BHEL Management about any fraud or suspected fraud as soon as it comes to their notice.			
32	Integrity Commitment: The offers of the bidders who are under suspension as also the offers of the bidders, who engage the services of the banned firms, shall be rejected. The list of banned firms is available on BHEL website www.bhel.com . Integrity commitment, performance of the contract and punitive action thereof:			
32.1	Commitment by BHEL: BHEL commits to take all measures necessary to prevent corruption in connection with the tender process and execution of the contract. BHEL will during the tender process treat all bidder(s) in a transparent and fair manner, and with equity.			
32.2	Commitment by bidder / Supplier / Contractor:			
32.2.1	<ul style="list-style-type: none"> - The bidder / supplier / contractor commits to take all measures to prevent corruption and will not directly or indirectly influence any decision or benefit which he is not legally entitled to nor will act or omit in any manner which tantamount to an offence punishable under any provision of the Indian Penal code, 1860 or any other law in force in India. - The bidder / supplier / contractor will, when presenting his bid, disclose any and all payments he has made, and is committed to or intends to make to agents, brokers or any other intermediaries in connection with the award of the contract and shall adhere to relevant guidelines issued from time to time by govt. of India / BHEL The bidder / supplier / contractor will perform / execute the contract as per the contract terms & conditions and will not default without any reasonable cause, which causes loss of business / money / reputation to BHEL.			
32.2.2	If any bidder / supplier / contractor during pre-tendering / tendering / post tendering / award / execution / post-execution stage indulges in mal-practices, cheating, bribery, fraud or / and other misconduct or formation of cartel so as to influence the bidding process or influence the price or acts or omits in any manner which tantamount to an offence punishable under any provision of the Indian Penal Code, 1860 or any other law in force in India, then action may be taken against such bidder / supplier / contractor as per the extant guidelines of the company available on www.bhel.com and / or under applicable legal provisions.			
32.2.3	Preventive checks to eliminate suspected cartel formation between suppliers The Bidder declares that they will not enter into any illegal or undisclosed agreement or understanding, whether formal or informal with other Bidder(s). This applies in particular to prices, specifications, certifications, subsidiary contracts, submission or non-submission of bids or any other actions to restrict competitiveness or to introduce cartelization in the bidding process. In case, the Bidder is found having indulged in above activities, suitable action shall be taken by BHEL as per extant policies/ guidelines Declaration by Bidders We declare that the following family firms or sister concern affiliates/ subsidiary firms are participating in the tender No _____ 1.0 _____ 2.0 _____ 3.0 _____ I _____ hereby declare on behalf of M/s _____ and family firms or sister concern affiliates/ subsidiary firms listed above that we are not indulging in cartel formation for Enquiry No _____. <div style="text-align: right;"> (_____) For M/s _____ Seal and Sign </div>			



BP 200102C

**BHARAT HEAVY ELECTRICALS LIMITED, BHOPAL
GENERAL TERMS AND CONDITIONS OF ENQUIRY**

33	<p>Public Procurement (Preference to Make in India), Order 2017</p> <p>" The local content to categorize a supplier as a Class I local supplier/ Class II local Supplier/ Non-local supplier and purchase preference to Class I local supplier, is as defined in Public Procurement (Preference to Make in India), Order 2017 dated 19.07.2024 issued by DPIIT. In case of subsequent orders issued by the nodal ministry, changing the definition of local content for the items of the NIT, the same shall be applicable even if issued after issue of this NIT, but before opening of Part-II bids against this NIT"</p> <p>For this procurement, Public Procurement (Preference to Make in India), Order 2017 Dtd 19.7.2024 and subsequent orders issued by both DPIIT and the respective nodal ministries shall be applicable.</p> <p>Bidder to mention the percentage of local content and place of value addition to manufacture these items in the tender in MII self-certificate/ self-declaration certificate.</p> <p>Bidder to refer the Sample format of MII self-certificate (Annexure - 1) and sample certification format of statutory auditor or cost auditor of the company (in the case of companies) or from a practicing cost accountant or practicing chartered accountant (in respect of suppliers other than companies) (Annexure- 2).</p>
34	RESTRICTION UNDER RULE 144 (xi) OF THE GENERAL FINANCIAL RULES 2017: As per latest government guidelines
34.1	Any bidder from a country which shares a land border with India will be eligible to bid in this tender only if the bidder is registered with the competent authority.
34.2	"Bidder" (including the term 'tenderer', 'consultant' or service provider' in certain contexts means any person or firm or company, including any member of a consortium or joint venture (that is an association of several persons, or firms or companies) every artificial juridical person not falling in any of the description of bidders stated hereinbefore, including any agency, branch or office controlled by such person, participating in procurement process.
34.3	Bidder from a country which shares a land border with India" for the purpose of this order means: - a. An entity incorporated, established or registered in such a country; or b. A subsidiary of an entity incorporated, established or registered in such a country; or c. An entity substantially controlled through entities incorporated, established or registered in such a county; or d. d. An entity whose beneficial owner is situated in such a country; or e. An Indian (or other) agent of such an entity; or f. A natural person who is a citizen of such a country; or g. A consortium or joint venture where any member of the consortium or joint venture falls under any of the above.
34.4	The beneficial owner for the purpose of (iii) above will be as under: 1. In case of company or Limited Liability Partnership, the beneficial owner is the natural person(s), who, whether acting alone or together, or through one or more juridical person, has a controlling ownership interest or who exercises control through other means. Explanation – a. "Controlling ownership interest" means ownership of or entitlement to more than twenty-five per cent of shares or capital or profits of the company. b. "Control" shall include the right to appoint majority of the directors or to control the management or policy decisions including by virtue of their shareholding or management rights or shareholder's agreements or voting agreements. 2. In case of a partnership firm, the beneficial owner is the natural person(s) who, whether acting alone or together, or through one or more juridical person, has ownership of entitlement to more than fifteen percent of capital or profits of the partnership; 3. In case of an unincorporated association or body of individuals, the beneficial owner is the natural person(s), who, whether acting alone or together, or through one or more juridical person, has ownership of or entitlement to more than fifteen percent of the property or capital or profits of such association or body of individuals; 4. Where no natural person is identified under (1) or (2) or (3) above, the beneficial owner is the relevant natural person who holds the position of senior managing official;



BP 200102C

**BHARAT HEAVY ELECTRICALS LIMITED, BHOPAL
GENERAL TERMS AND CONDITIONS OF ENQUIRY**

	5. In case of a trust, the identification of beneficial owner(s) shall include identification of the author of the trust, the trustee, the beneficiaries with fifteen percent or more interest in the trust and any other natural person exercising ultimate effective control over the trust through a chain of control or ownership.
34.5	An Agent is a person employed to do any act for another, or to represent another in dealings with third person.
34.6	Model certificate for Tenders <i>"I have read the clause regarding restrictions on procurement from a bidder of a country which shares a land border with India; I certify that this bidder is not from such a country or, if from such a country, has been registered with the competent authority. I hereby certify that this bidder fulfils all requirements in these regards and is eligible to be considered. [Where applicable, evidence of valid registration by the Competent Authority shall be attached]."</i>
35	Treatment of cases regarding conflict of interest: The bidder notes that a conflict of interest would said to have occurred in the tender process and execution of the resultant contract, in case of any of the following situations: <ol style="list-style-type: none">1) If its personnel have a close personal, financial, or business relationship with any personnel of BHEL who are directly or indirectly related to the procurement or execution process of the contract, which can affect the decision of BHEL directly or indirectly.2) The bidder (or his allied firm) provided services for the need assessment/ procurement planning of the Tender process in which it is participating.3) Procurement of goods directly from the manufacturers/ suppliers shall be preferred. However, if the OEM/ Principal insists on engaging the services of an agent, such agent shall not be allowed to represent more than one manufacturer/ supplier in the same tender. Moreover, either the agent could bid on behalf of the manufacturer/ supplier or the manufacturer/ supplier could bid directly but not both. In case bids are received from both the manufacturer/ supplier and the agent, bid received from the agent shall be ignored. However, this shall not debar more than one Authorised distributor (with/ or without the OEM). from quoting equipment manufactured by an Original Equipment Manufacturer (OEM) in procurements under a Proprietary Article Certificate.4) A bidder participates in more than one bid in this tender process. Participation in any capacity by a Bidder (including the participation of a Bidder as a partner/ JV member or sub-contractor in another bid or vice-versa) in more than one bid shall result in the disqualification of all bids in which he is a party. However, this does not limit the participation of an entity as a sub-contractor in more than one bid if he is not bidding independently in his own name or as a member of a JV. The Bidder shall declare that they have read and understood the above aspects, and the bidder confirms that such conflict of interest does not exist and undertakes that they will not enter into any illegal or undisclosed agreement or understanding, whether formal or informal with other Bidder(s), in this regard. This applies in particular to prices, specifications, certifications, subsidiary contracts, submission or non-submission of bids or any other actions to restrict competitiveness or to introduce cartelization in the bidding process. In case, the Bidder is found having indulged in above activities, the same will be considered as a violation of the tender conditions, and suitable action shall be taken by BHEL as per extant policies/ guidelines. - Duly filled, seal and signed declaration to be submitted by bidders with Part1- techno commercial offers of each tender.
36	Breach of contract, Remedies and Termination
36.1	The following shall amount to breach of contract: <ol style="list-style-type: none">I. Non-supply of material/ non-completion of work by the Supplier/Vendor within scheduled delivery/ completion period as per contract or as extended from time to time.



BP 200102C

BHARAT HEAVY ELECTRICALS LIMITED, BHOPAL GENERAL TERMS AND CONDITIONS OF ENQUIRY

	<p>II. The Supplier/Vendor fails to perform as per the activity schedule and there are sufficient reasons even before expiry of the delivery/ completion period to justify that supplies shall be inordinately delayed beyond contractual delivery/ completion period.</p> <p>III. The Supplier/Vendor delivers equipment/ material not of the contracted quality.</p> <p>IV. The Supplier/Vendor fails to replace the defective equipment/ material/ component as per guarantee clause.</p> <p>V. Withdrawal from or abandonment of the work by the Supplier/Vendor before completion as per contract.</p> <p>VI. Assignment, transfer, subletting of Contract by the Supplier/Vendor without BHEL's written permission resulting in termination of Contract or part thereof by BHEL.</p> <p>VII. Non-compliance to any contractual condition or any other default attributable to Supplier/Vendor.</p> <p>VIII. Any other reason(s) attributable to Vendor towards failure of performance of contract.</p> <p>In case of breach of contract, BHEL shall have the right to terminate the Purchase Order/ Contract either in whole or in part thereof without any compensation to the Supplier/Vendor.</p> <p>IX. Any of the declarations furnished by the contractor at the time of bidding and/ or entering into the contract for supply are found untruthful and such declarations were of a nature that could have resulted in non-award of contract to the contractor or could expose BHEL and/ or Owner to adverse consequences, financial or otherwise.</p> <p>X. Supplier/Vendor is convicted of any offence involving corrupt business practices, antinational activities or any such offence that compromises the business ethics of BHEL, in violation of the Integrity Pact entered into with BHEL has the potential to harm the overall business of BHEL/ Owner.</p> <p>Note-Once BHEL considers that a breach of contract has occurred on the part of Supplier/Vendor, BHEL shall notify the Supplier/Vendor by way of notice in this regard. Contractor shall be given an opportunity to rectify the reasons causing the breach of contract within a period of 14 days.</p> <p>In case the contractor fails to remedy the breach, as mentioned in the notice, to the satisfaction of BHEL, BHEL shall have the right to take recourse to any of the remedial actions available to it under the relevant provisions of contract.</p>
36.2	<p><u>Remedies in case of Breach of Contract.</u></p> <p>i) Wherein the period as stipulated in the notice issued under clause 14.1 has expired and Supplier/Vendor has failed to remedy the breach, BHEL will have the right to terminate the contract on the ground of "Breach of Contract" without any further notice to contractor.</p> <p>ii) Upon termination of contract, BHEL shall be entitled to recover an amount equivalent to 10% of the Contract Value for the damages on account of breach of contract committed by the Supplier/Vendor. This amount shall be recovered by way of encashing the security instruments like performance bank guarantee etc available with BHEL against the said contract. In case the value of the security instruments available is less than 10% of the contract value, the balance amount shall be recovered from other financial remedies (i.e. available bills of the Supplier/Vendor, retention amount, from the money due to the Supplier/Vendor etc. with BHEL) or the other legal remedies shall be pursued.</p> <p>iii) wherever the value of security instruments like performance bank guarantee available with BHEL against the said contract is 10% of the contract value or more, such security instruments to the extent of 10% contract value will be encashed. In case no security instruments are available or the value of the security instruments available is less than 10% of the contract value, the 10% of the contract value or the balance amount, as the case may be, will be recovered in all or any of the following manners:</p> <p>iv) In case the amount recovered under sub clause (a) above is not sufficient to fulfil the amount recoverable then; a demand notice to deposit the balance amount within 30 days shall be issued to Supplier/Vendor.</p> <p>v) If Supplier/Vendor fails to deposit the balance amount within the period as prescribed in demand notice, following action shall be taken for recovery of the balance amount:</p> <p>a. from dues available in the form of Bills payable to defaulted Supplier/Vendor against the same contract.</p> <p>b. If it is not possible to recover the dues available from the same contract or dues are insufficient to meet the recoverable amount, balance amount shall be recovered from any money(s) payable to</p>



BP 200102C

**BHARAT HEAVY ELECTRICALS LIMITED, BHOPAL
GENERAL TERMS AND CONDITIONS OF ENQUIRY**

	<p>Supplier/Vendor under any contract with other Units of BHEL including recovery from security deposits or any other deposit available in the form of security instruments of any kind against Security deposit or EMD.</p> <p>c. In-case recoveries are not possible with any of the above available options, Legal action shall be initiated for recovery against defaulted supplier/Vendor.</p> <p>vi) It is an agreed term of contract that this amount shall be a genuine pre-estimate of damages that BHEL would incur in completion of balance contractual obligation of the contract through any other agency and BHEL will not be required to furnish any other evidence to the Supplier/Vendor for the purpose of estimation of damages.</p> <p>vii) In addition to the above, imposition of liquidated damages, debarment, termination, de-scoping, short-closure, etc., shall be applied as per provisions of the contract.</p> <p>Note: 1) The defaulting Supplier/Vendor shall not be eligible for participation in any of the future enquiries floated by BHEL to complete the balance work. The defaulting contractor shall mean and include: (a) In case defaulted Supplier/Vendor is the Sole Proprietorship Firm, any Sole Proprietorship Firm owned by same Sole Proprietor. (b) In case defaulted Supplier/Vendor is The Partnership Firm, any firm comprising of same partners/ some of the same partners; or sole proprietorship firm owned by any partner(s) as a sole proprietor.</p>
37	<p>Option clause: The Purchaser reserves the right to decrease the quantity to be ordered at the time of placement of contract. The purchaser also reserves the right to increase the ordered quantity by up to 25% of the contracted quantity during the currency of the contract at the contracted rates. Bidders are bound to accept the orders accordingly.</p>
38	<p>NOTE:</p> <ol style="list-style-type: none">1. In the event of our customer order covering this tender being cancelled /placed on hold /otherwise modified, BHEL would be constrained to accordingly cancel / hold / short close /modify the tender at any stage of execution.2. BHEL may negotiate the L1 rate, if not meeting our budget / estimated cost. BHEL may re-float the tender opened, if L1 price is not acceptable to BHEL even after negotiation.
39	<p><u>Grievance Redressal Mechanism</u></p> <p>To promote transparency and ensure fair treatment of all bidders, a structured Grievance Redressal Mechanism is in place to address any concerns or issues arising during the tendering process or in subsequent business dealings with the company.</p> <p>Suppliers/Contractors are requested to follow the below escalation process for grievance resolution:</p> <ol style="list-style-type: none">1. First Level: Any grievance should initially be addressed to the designated Dealing Officer, whose contact details are provided in the Notice Inviting Tender (NIT)/Contract.2. Second Level: If the issue remains unresolved, it may be escalated by lodging a formal grievance through the SUVIDHA Portal: https://suvidha.bhel.in/suvidha/. Responses will be provided in accordance with the defined escalation matrix.”

Note:

- 1.0 Tender Specific conditions shall override relevant provisions of this GTC
- 2.0 In the event of any change as notified by Govt. of India same will supersede the relevant GTC clause.



BP 200102C

**BHARAT HEAVY ELECTRICALS LIMITED, BHOPAL
GENERAL TERMS AND CONDITIONS OF ENQUIRY**

Annexure 2-

Format - Auditor Certificate for MII

CERTIFICATION REGARDING MINIMUM LOCAL CONTENT IN LINE WITH REVISED PUBLIC PROCUREMENT (PREFERENCE TO MAKE IN INDIA), ORDER 2017 DATED 19.7.24 AND SUBSEQUENT ORDER(S)

(To be provided on the Letter head of Auditor/PCA)

To, _____ (Write Name and Address of the bidder);

Ref : 1) BHEL NIT/Tender Specification No: _____, 2) Name of items :
3) All other pertinent issues till date

We statutory auditor of the company / cost auditor of the company / practicing cost accountant / practicing chartered accountant ** hereby certify that the items/works/services offered by..... (specify the name of the organization here) has a local content of _____ %

The local content % certified above is in line with the definition of Local content given in point no 2 of Public Procurement (Preference to Make in India), Order 2017 Revision dated 19.7.2024 issued by DPIIT and subsequent order(s) to qualify as (Class-I/ CLASS-I I/ Non-Local supplier-fill in one which is applicable) local supplier.
The details of the location(s) at which the local value addition is made are as follows:

We confirm that the following has not been considered for calculation of local content:

- Imported items sourced locally from resellers/distributors.
- The license fees/ royalties paid/ technical charges paid out of India
- Refurbishment/Repackaging/ Rebranding of imported products
- services such as transportation, insurance, installation, commissioning, training and after sales service support like AMC/CMC etc.

**We confirm that since contract involves supply of multiple items, weighted average of all items has been taken while calculating the local content.

I hereby declare that the details furnished above are true and correct to the best of my knowledge and belief. In case any of the above information is found to be false or untrue or misleading or misrepresenting, I am aware that I may be held liable for it.

Auditor Details

For(Firm Name)

Name of Auditor:

**Partner/Proprietor:

Membership No. **(ICAI/ICMAI): Firm Registration

No. (FRN): Signature & Seal of Auditor UDIN:

Date:

Place:



BP 200102C

BHARAT HEAVY ELECTRICALS LIMITED, BHOPAL GENERAL TERMS AND CONDITIONS OF ENQUIRY

** - Strike out whichever is not applicable.

Note: For evaluation of qualification of bidder:

1. For items sold by bidder as reseller, OEM certificate for country of origin to be submitted.
2. Certificate is required from Statutory Auditor or Cost Auditor (if the bidder is a company) or from a practicing Chartered Accountant or practicing Cost Accountant (if the bidder is other than a company) giving the percentage of local content.



BP 200102C

**BHARAT HEAVY ELECTRICALS LIMITED, BHOPAL
GENERAL TERMS AND CONDITIONS OF ENQUIRY**

Company Letter head

Annexure **A**

Date: {insert date}

To,
Bharat Heavy Electricals Limited
Piplani
Bhopal-462023
Madhya Pradesh
India

I/We hereby certify (for the period from* _____ to _____) that,

1. {Name of company} (Vendor Code with BHEL) is a company incorporated on {insert date}{insert date} under the {Law of the Country}
2. It is a tax resident as per the Tax Laws of {country}.
3. The Company does not have and is not likely to have a permanent establishment in India as defined in Article 5 of the Agreement for Avoidance of Double Taxation between India and _____ ("the tax treaty" for short).
4. In this regard, it is further confirmed that:
 - the Company does not have or is not likely to have a fixed place of business in India through which its business is wholly or partly conducted as stipulated in Article 5 of the tax treaty
 - the Company does not have or is not likely to have any dependent agent in India as stipulated in Article 5 of the tax treaty
5. The company does not have any business connection in India as per Sec 9(1) of the Indian Income Tax Act 1961 through which business is carried on in India.

I hereby declare that the above information is correct and complete to the best of my knowledge and belief. Further I undertake to promptly inform the Company (i.e. BHEL) in writing should there be any change in the facts given above.

I/We, my/our legal heirs, executors and administrators hereby indemnify and keep indemnified the Company (i.e. BHEL) for any loss (including but not limited to tax, interest and penalty) suffered by as a result of the Company (i.e. BHEL) relying on this declaration and/or my delay/default in confirming the change, if any, in the facts mentioned above. This obligation shall be in force at all times.

This certificate is being issued to the Customer / Client / Payee to enable them to decide upon the With Holding Tax applicable on transaction with our company.

If there is any change in the above facts the same would be intimated to you.

For& On behalf of

{Insert name of the company}

Authorized Signatory with Seal

*The period can be decided by the issuer & no fresh certificate will be asked for releasing payment within this



BP 200102C

BHARAT HEAVY ELECTRICALS LIMITED, BHOPAL GENERAL TERMS AND CONDITIONS OF ENQUIRY

Company Letter head

Annexure **B**

Date: {insert date}

To,
Bharat Heavy Electricals Limited
Piplani
Bhopal-462023
Madhya Pradesh
India

I/We hereby certify (for the period from * _____ to _____) that,

1. {Name of company} (Vendor Code with BHEL) is a company incorporated on {insert date}{insert date} under the {Law of the Country}
2. It is a tax resident as per the Tax Laws of {country}.
3. The Company has its permanent establishment in India as defined in Article 5 of the Agreement for Avoidance of Double Taxation between India and _____ ("the tax treaty" for short).
And/or
4. the Company has a fixed place of business in India through which its business is wholly or partly conducted as stipulated in Article 5 of the tax treaty
And/or
5. the Company has agent(not of independent status) in India as stipulated in Article 5 of the tax treaty
And/or
6. The company has business connection in India as per Sec 9(1) of the Indian Income Tax Act 1961 through which its business is carried on in India.

But as far as our business dealing with your organization is concerned we are not using this permanent establishment and business connections and we are dealing directly from our office situated in _____.

I hereby declare that the above information is correct and complete to the best of my knowledge and belief. Further I undertake to promptly inform the Company (i.e. BHEL) in writing should there be any change in the facts given above.

I/We, my/our legal heirs, executors and administrators hereby indemnify and keep indemnified the Company (i.e. BHEL) for any loss (including but not limited to tax, interest and penalty) suffered by as a result of the Company (i.e. BHEL) relying on this declaration and/or my delay/default in confirming the change, if any, in the facts mentioned above. This obligation shall be in force at all times.

This certificate is being issued to the Customer / Client / Payee to enable them to decide upon the With Holding Tax applicable on transaction with our company.

If there is any change in the above facts the same would be intimated to you.

For & On behalf of

{Insert name of the company}



BP 200102C

BHARAT HEAVY ELECTRICALS LIMITED, BHOPAL GENERAL TERMS AND CONDITIONS OF ENQUIRY

FORM NO. 10F

[See sub-rule (1) of rule 21AB]

Information to be provided under sub-section (5) of section 90 or sub-section (5) of section 90A of the Income-tax Act, 1961

I, *son/daughter of Shri..... in the capacity of (designation) do provide the following information, relevant to the previous year..... *in my case/in the case of..... for the purposes of sub-section (5) of *section 90/section 90A:—

Sl.No	Nature of information	:	Details #
(i)	Status (individual, company, firm etc.) of the assessee	:	
(ii)	Permanent Account Number or Aadhaar Number of the assessee if allotted	:	
(iii)	Nationality (in the case of an individual) or Country or specified territory of incorporation or registration (in the case of others)	:	
(iv)	Assessee's tax identification number in the country or specified territory of residence and if there is no such number, then, a unique number on the basis of which the person is identified by the Government of the country or the specified territory of which the assessee claims to be a resident	:	
(v)	Period for which the residential status as mentioned in the certificate referred to in sub-section (4) of section 90 or sub-section (4) of section 90A is applicable	:	
(vi)	Address of the assessee in the country or territory outside India during the period for which the certificate, mentioned in (v) above, is applicable	:	

2. I have obtained a certificate referred to in sub-section (4) of section 90 or sub-section (4) of section 90A from the Government of (name of country or specified territory outside India)

Signature:

Name:

Address:

Permanent Account Number or Aadhaar Number



BP 200102C

BHARAT HEAVY ELECTRICALS LIMITED, BHOPAL GENERAL TERMS AND CONDITIONS OF ENQUIRY

I do hereby declare that to the best of my knowledge and belief what is stated above is correct, complete and is truly stated.

Verified today the day of.....

.....

Signature of the person providing the information

Place:

Notes :

1. *Delete whichever is not applicable.
2. #Write N.A. if the relevant information forms part of the certificate referred to in sub-section (4) of section 90 or sub-section (4) of section 90A.



BP 200102C

BHARAT HEAVY ELECTRICALS LIMITED, BHOPAL GENERAL TERMS AND CONDITIONS OF ENQUIRY

CBDT Notification dtd 28.03.2023 reg Partial relaxation in r/o filing of Form 10F electronically by select category of taxpayers

Dear sir/Madam,

The relaxation provided by the CBDT reg. Online Filing of Form 10F by the Non-resident taxpayer for availing the benefit of DTAA, has expired on 30.09.2023. Therefore, on the expiry of the exemption period, the Income-tax department has now enabled a new category under 'Others' while registering on the income tax portal, i.e., 'non-residents not holding and not required to have PAN'.

Procedure for registration

- The non-resident can click on the 'Register' option on the e-filing portal, i.e., <https://www.incometax.gov.in/iec/foportal>
- Under the 'others' category, there is an option to choose 'non-residents not holding and not required to have PAN'.
- Certain basic details will need to be entered, like name, date of incorporation, tax identification number, status, and country of residence.
- The non-resident will then have to provide the details of the key person, i.e., name, date of birth, etc.
- The next step is to provide contact details, i.e., email address and mobile number, which will be verified through an OTP.
- Lastly, the non-resident will need to upload certain documents like its TRC, address proof, identification proof, and any other document if required.

Once the non-resident is registered on the portal, it can file Form 10F electronically without having to obtain a PAN in India.

In view of, It is to be ensured that while providing DTAA benefit to Non-resident, it must be ensured that e-filed Form 10F is obtained along with other documents (i.e. TRC, NO PE etc.) to avoid any additional demand, penalty, interest etc.

Manual Form 10F shall not be accepted by the I.T. Deptt. for Payment made to Non-resident on or after 01.10.2023.



BP 205315

BHEL, P.O. TERMS & CONDITIONS (INDIGENOUS)

The Purchase Order is subject to the following Terms & Conditions unless otherwise specified and directed. Vendors may also login to B2B portal (Link: <https://www.bhelbpl.co.in/mm/>) for any information regarding PO, rejections / acceptance, bills, etc.

1. ORDER ACKNOWLEDGEMENT:

Order acknowledgement must reach the concerned officer of Materials Management Division within 10 days of issue of purchase order. Failure to do so within stipulated period would be deemed to mean that the order has been accepted by the supplier.

2. PACKING:

2.1 The supplier shall securely protect and pack the goods against loss, damage or corrosion in the transit. Packing shall allow for easy removal and checking on site and comply with carrier conditions of packing or established trade practice.

2.2 Cases and packing materials shall be supplied free of charge unless otherwise agreed to. Wherever specifically agreed to, empties shall be returned at supplier's expenses but no liability will be accepted by BHEL in respect thereof.

2.3 Damage to the consignment resulting out of poor/inferior packing shall be to the account of the supplier.

3. MARKING:

3.1 The following details clearly marked on each case/box/packing/bundle and reel.

i) Consignee ii) BHEL Order No. iii) Gross Weight iv) Net Weight v) Dimensions in mm vi) Brief description of item vii) BHEL Destination Code (refer purchase order) viii) Consignor.

3.2 All marking for safety, proper handling, storage, protection etc. are to be clearly marked on the case as per Indian Standard.

4. CONSIGNEE:

Unless otherwise mentioned, all goods shall be consigned as noted below:

4.1 Road: AGM, Central Receiving Section Block VII, BHEL. Despatches must be arranged through BHEL's approved transporters on door delivery basis, in case of ex-works delivery terms.

4.2 Post/Air parcel: AGM, Central Receiving Section Block VII BHEL, Bhopal – 462 022.

4.3 Supplier not complying with instructions at (a) & (b) above shall do so at their risk and cost.

5. DOCUMENTATION:

The supplier shall forward four sets of the documents as details below: -

5.1 1st set to the concerned Purchase Officer, BHEL Bhopal- 462 022, comprising of following, as applicable:

5.1.1 GST Invoice 1 copy

5.1.2 Challan/Despatch Advice note 2 copies

5.1.3 Guarantee Certificate 2 copies

5.1.4 Test Certificate 2 copies

5.1.5 Photo copy of LR/RR 1 copy

5.1.6 MDCC 1 copy

5.1.7 Copy of E-way bill as applicable 1 copy

5.2 2nd set to AGM, Central Receiving Section, Block-VII, BHEL, Bhopal-462 022, comprising of: -

5.2.1 Original LR /RR (if not negotiated through Bank)

5.2.2 GST Invoice 2 copies

5.2.3 Challan/Despatch Advice note 2 copies

5.3 3rd set to DGM, Purchase Bills Section, 4th floor Administrative Building, BHEL Bhopal- 462 022, Comprising of:-

5.3.1 Original Signed invoice 2 copies

5.3.2 LR copy 1 copy

5.3.3 Challan Copy 1 copy

5.3.4 Free Issue Material Statement (FIMS) 1 copy (For POs on Labour / mixed basis)

5.3.5 Scrap Retention Intimation Slip (SRIS) 1 copy (For POs on Labour / mixed basis)

5.3.6 Scrap Return Note (SCRN) 1 copy (For POs on Labour / mixed basis)

5.3.7 Copy of material issue gate pass 1 copy (For POs on Labour / mixed basis)

5.3.8 E & C Certificate 1 Copy For erection / commissioning bill payments

5.3.9 Price Variation Clause (PVC) calculation sheet in case PVC applicable 1 copy

Note: Vendor to issue tax invoices fully compliant with the GST invoice rules



BP 205315

BHEL, P.O. TERMS & CONDITIONS (INDIGENOUS)

- 5.4 4th set (Only in case of documents negotiated through Bank) to the bank separately for each P.O. comprising of:-
- 5.4.1 Original LR/RR
- 5.4.2 Signed invoice 2 copies
- 5.4.3 Test certificate 1 copy
- 5.4.4 Guarantee Certificate 1 copy
6. Tax paying document:
The original GST invoice indicating HSN/SAC CODES and drawn in favour of BHEL, Bhopal for each consignment shall accompany the transporters in case of road despatches and with R/R in case of rail despatches. In case of any other mode of despatch (such as Regd. Post Parcel/Air Parcel etc.) the same shall be forwarded to AGM, Central Receiving Section, Block-VII, BHEL, Bhopal-462 002 directly by registered post/hand delivery. The tax-paying document must not be enclosed inside the packing case. No GST shall be paid in the absence of the above document.
7. INDEMNITY:
Supplier shall indemnify BHEL against the following:
- 7.1 Any claim of Infringement of letters, patent or registered design by the use or sale of any article or materials supplied to BHEL and against all costs and damages, which may incur in any action for such infringement or for which BHEL become liable in any such action.
- 7.2 All claims for injury or damages caused by the supplier's negligence or negligence of supplier's employee or arising from any defect in the goods supplied or on the work carried out the supplier.
- 7.3 All claims for injury to the supplier's employees or agent's employees whilst on BHEL premise.
Any claim for material that has been rejected by BHEL and that has NOT been removed by supplier within 90 days of intimation regarding rejection.

From: Administrator.Bpl <administrator.bpl@bhel.in>
Sent: 29 May 2026 11:49
To: all.bpl@bhel.in
Subject: Latest Stamp Duty guidelines
Attachments: Stamp Duty .pdf

Respected Sir,

With reference to the numerous queries raised by various departments concerning recent changes in stamp duty, I again request that the amended Stamp Duty guidelines (Attached) be circulated through an admin email for all.

- With reference to many query latest stamp duty as per **Indian Stamp (Madhya Pradesh Amendment) Act, 2025** is as follows:-

Indian Stamp (Madhya Pradesh Amendment) Act, 2025 was published around [30 July 2025](#) and Effective [September 9, 2025](#) . It amends the Indian Stamp Act, 1899, specifically for documents executed in MP.

Under this amendment, **stamp duty rates for many legal documents were substantially increased** as per the Gazette and subsequent notification (published on 09.09.2025).

- **Key changes in rates under the new MP stamp duty rules (effective from Sept 9, 2025):**

- **Affidavits / Sworn statements (शपथ पत्र)** increased from ₹50 → **₹200**
- **Partnership deeds, consent deeds, registry amendments, etc., also saw hikes** often to ₹2,000–₹5,000 ranges depending on document type.
- **Power of Attorney (multiple transactions) :** Increased from ₹1,000 to **₹5,000**
- **Agreements (including many contractual agreements)** Certain categories of agreements, earlier attracting lower fixed duty, (e.g., agreements up to Rs.50 lakh →have been revised to ₹1,000 or ₹5,000 depending on value and nature, and In **Madhya Pradesh**, the stamp duty applicable to a **works contract (contract with a contractor) exceeding Rupees 50 lakhs is 0.2% of the total contract value, subject to a maximum of Rupees 10 lakhs).**

1. If the contract value exceeds ₹50 lakh due to amendment in work order, a new agreement will be made on the full value or 0.2% of the increased amount.

Opinion:

If the contract value increases due to amendment of the work order, stamp duty is payable only on the increased amount at 0.2%, not on the entire contract value again.

2. If the work order is amended due to changes in the work order period and other reasons (except increase in work order value), whether a new agreement is required? If yes, please confirm stamp duty rates.

Opinion:

Yes, New contract can be executed for the additional work. Stamp duty on the value of additional work in such a case will be at the prevailing rate on the amount of the fresh agreement and not the total value of the work.

(i) Where the value of the contract exceeds Rs. 50 lakh

Stamp duty payable = **0.2% of the contract value (ad-valorem duty).**

(ii) Where the agreement is amended without change in consideration (contract value) The document is treated as a **Supplementary / Amendment / Rectification Agreement**, and **fixed stamp duty is payable.**

(iii) Under the latest amendment, fixed stamp duty for such agreement / rectification type instruments is Rs. 5,000.

WITH REGARDS.



संतोष कुमार सेन (HRM-LAW)

Prerna Bhawan

बीएचईएल, भोपाल/BHEL BHOPAL

Direct : 0755 2503670,

Email- : santoshsen@bhel.in

From: Santosh <santoshsen@bhel.in>
To: Sanjeev <sanjeev.lugun@bhel.in>
Cc: Janmejaya <janmejaya1@bhel.in>; Namrata <njaiswal@bhel.in>; Surekha <skhanore@bhel.in>;
Thakur <tusingh@bhel.in>; Chitresh <cdatta@bhel.in>; mksrivastava <mksrivastava@bhel.in>;
sudhasharma <sudhasharma@bhel.in>
Date: Wednesday, 25 March 2026 2:00 PM IST
Subject: Fwd : Latest Stamp Duty guidelines

Respected Sir,

Instructions/Checklist for Vendors :

- 1) Bank Guarantee / BG Extention shall be made strictly as per BHEL's Standard format as available on B2B site.
- 2) **Validity date** must be explicitly mentioned in the BG. There should be adequate gap, preferably 3-6 months between Validity date and Claim date.
- 3) **Claim Date** must be mentioned in the BG.
- 4) **Confirmation:** As per Corporate and RBI guideline confirmation is required in respect of each BG. Confirmation may be provided by the same issuing branch by the officials higher in rank or from the office mentioned in the BG for confirmation. Thus Vendors must ensure that BG bears the Confirmation office address explicitly.
- 5) **Stamps:** Stamps must be purchased from registered stamp vendor. Stamp purchase date must be old than the date of the execution of the Bank Guarantee. E stamp is also allowed. Stamp must be purchased for BG purposes only. Place of execution of BG and purchase of stamp shall be in the same State.
- 6) **Value of stamp must be as per Stamp act prevailing in the state where the BG is submitted or the state where the BG executed, whichever is higher.**
- 7) **Bank Seal and sign of Bank Employee:** BG must be signed and sealed on every page of the BG. Employee Name and Code must be present in the BG at the end of the BGs text. Every BG having value more than 50,000/- must be signed by two authorized signatories of the bank.
- 8) **Place of Invocation must mention on BG.**
- 9) **BGs should not be from the co-operative banks**
- 10) **BGs can be issued through consortium banks only.**
- 11) **Vendors must provide the BG from banks which are already SFMS Compliant. If vendors banks are not SFMS Compliant, a declaration from bank is required. For sending SFMS bank detail is - ACCOUNT HOLDER: BHARAT HEAVY ELECTRICALS LTD., CURRENT ACCOUNT NO. : 30855948540, BANK : SBI, HET BHOPAL,IFSC: SBIN0000519, MICR : 462002011.**
- 12) **Email ID, phone no, Fax No of bank must mention on BG.**
- 13) **Extension/Amendment of BG is required on Rs. 1000/- Stamp Paper.**
- 14) **Bank Guarantee for Advance Payment – The BG shall be for 110% of the value of advance.**
- 15) **Cutting / overwriting on the BG shall be properly authenticated under signature and seal of the executing Bank.**
- 16) **Latest Solvency certificate:** Latest Solvency Certificate in original, with **Bank Seal and sign of Bank Employee**, in BHEL's standard format shall be enclosed with Sub Contracting BG.
- 17) **BG documents wherein corrections have been marked may also be enclosed with final corrected BG, where original BG document is being replaced.**
- 18) **Digital signed secured email confirmation required from BG issuing bank.**

List of Consortium Banks

List of Consortium Banks			
	Nationalized Banks		Nationalized Banks
1	Allahabad bank	19	Vijaya Bank
2	Andhra bank		Public Sector Banks
3	Bank of Baroda	20	IDBI
4	Canara Bank		Foreign banks
5	Corporation bank	21	CITI Bank NA
6	Central bank	22	Deutsche Bank AG
7	Indian Bank	23	The Hongkong and Shanghai Banking Corporation Limited
8	Indian Overseas Bank	24	Standard Chartered Bank
9	Oriental bank of Commerce	25	JP Morgan
10	Punjab National Bank		Private Banks
11	Punjab & Sindh Bank	26	Axis Bank
12	State Bank of India	27	The Federal Bank
13	State Bank of Hyderabad	28	HDFC
14	Syndicate Bank	29	Kotak Mahindra Bank Limited
15	State Bank of Travancore	30	ICICI Bank
16	UCO Bank	31	Indusind Bank
17	Union Bank of India	32	Yes Bank
18	United Bank of India		

Annexure- C

BANK GUARANTEE FOR PERFORMANCE SECURITY

Bank Guarantee No:

Date:

To

NAME
& ADDRESSES OF THE BENEFICIARY

Dear Sirs,

In consideration of Bharat Heavy Electricals Limited (hereinafter referred to as the 'Employer' which expression shall unless repugnant to the context or meaning thereof, include its successors and permitted assigns) incorporated under the Companies Act, 1956 and having its registered office at **BHEL HOUSE Siri Fort, New Delhi-110049** _____¹ through its Unit at...**BHEL BHOPAL**.....(name of the Unit) having awarded to (Name of the Vendor / Contractor / Supplier) with its registered office at _____² hereinafter referred to as the ' Vendor / Contractor / Supplier ', which expression shall unless repugnant to the context or meaning thereof, include its successors and permitted assigns), a contract Ref No.....dated³ valued at Rs.....⁴ (Rupees -----)/FC.....(in words.....) for⁵ (hereinafter called the 'Contract') and the Vendor / Contractor / Supplier having agreed to provide a Contract Performance Bank Guarantee, equivalent to% (.... Percent) of the said value of the Contract to the Employer for the faithful performance of the Contract,

we,, (hereinafter referred to as the Bank), having registered/Head office at and inter alia a branch at being the Guarantor under this Guarantee, hereby, irrevocably and unconditionally undertake to forthwith and immediately pay to the Employer any sum or sums upto a maximum amount of Rs -----⁶ (Rupees -----) without any demur, immediately on first demand from the Employer and without any reservation, protest, and recourse and without the Employer needing to prove or demonstrate reasons for its such demand.

Any such demand made on the Bank shall be conclusive as regards the amount due and payable by the Bank under this guarantee. However, our liability under this guarantee shall be restricted to an amount not exceeding Rs. _____.

We undertake to pay to the Employer any money so demanded notwithstanding any dispute or disputes raised by the Vendor / Contractor / Supplier in any suit or proceeding pending before any Court or Tribunal, Arbitrator or any other authority, our liability under this present being absolute and unequivocal.

The payment so made by us under this Guarantee shall be a valid discharge of our liability for payment thereunder and the Vendor / Contractor / Supplier shall have no claim against us for making such payment.

We thebank further agree that the guarantee herein contained shall remain in full force and effect during the period that would be taken for the performance of the said Contract/satisfactory completion of the performance guarantee period as per the terms of the Contract and that it shall continue to be enforceable till all the dues of the Employer under or by virtue of the said Contract have been fully paid and its claims satisfied or discharged.

WeBANK further agree with the Employer that the Employer shall have the fullest liberty without our consent and without affecting in any manner our obligations hereunder to vary any of the terms and conditions of the said Contract or to extend time of performance by the said Vendor / Contractor / Supplier from time to time or to postpone for any time or from time to time any of the

powers exercisable by the Employer against the said Vendor / Contractor / Supplier and to forbear or enforce any of the terms and conditions relating to the said Contract and we shall not be relieved from our liability by reason of any such variation, or extension being granted to the said Vendor / Contractor / Supplier or for any forbearance, act or omission on the part of the Employer or any indulgence by the Employer to the said Vendor / Contractor / Supplier or by any such matter or thing whatsoever which under the law relating to sureties would but for this provision have effect of so relieving us.

The Bank also agrees that the Employer at its option shall be entitled to enforce this Guarantee against the Bank as a principal debtor, in the first instance without proceeding against the Vendor / Contractor / Supplier and notwithstanding any security or other guarantee that the Employer may have in relation to the Vendor / Contractor / Supplier 's liabilities.

This Guarantee shall remain in force upto and including..... 7 and shall be extended from time to time for such period as may be desired by Employer.

This Guarantee shall not be determined or affected by liquidation or winding up, dissolution or change of constitution or insolvency of the Vendor / Contractor / Supplier but shall in all respects and for all purposes be binding and operative until payment of all money payable to the Employer in terms thereof. Unless a demand or claim under this guarantee is made on us in writing on or before thewe shall be discharged from all liabilities under this guarantee thereafter.

We, BANK lastly undertake not to revoke this guarantee during its currency except with the previous consent of the Employer in writing.

Any claim or dispute arising under the terms of this document shall only be enforced or settled in the Courts at Bhopal.

The guarantor hereby declare that it has power to execute this guarantee and the executant has full powers to do so on its behalf under the proper authorities granted to him by the of the guarantor.

Further Bank (Name of the BANK) certifies that this guarantee is adequately stamped under the relevant State Stamp Act and any deficiency in execution of this Guarantee shall not have the effect of relieving us

Notwithstanding anything to the contrary contained hereinabove:

a) The liability of the Bank under this Guarantee shall not exceed..... 6

b) This Guarantee shall be valid up to7

c) Unless the Bank is served a written claim or demand on or before _____ 8 all rights under this guarantee shall be forfeited and the Bank shall be relieved and discharged from all liabilities under this guarantee irrespective of whether or not the original bank guarantee is returned to the Bank We, _____ Bank, have power to issue this Guarantee under law and the undersigned as a duly authorized person has full powers to sign this Guarantee on behalf of the Bank.

For and on behalf of
(Name of the Bank)

Date.....

Place of Issue.....

BANK E-MAIL ID:

BANK PHONE NO.

BANK FAX NO:

1 NAME AND ADDRESS OF EMPLOYER I.e Bharat Heavy Electricals Limited

2 NAME AND ADDRESS OF THE VENDOR /CONTRACTOR / SUPPLIER.

3 DETAILS ABOUT THE NOTICE OF AWARD/CONTRACT REFERENCE

4 CONTRACT VALUE

5 PROJECT/SUPPLY DETAILS

6 BG AMOUNT IN FIGURES AND WORDS

⁷ VALIDITY DATE

⁸ DATE OF EXPIRY OF CLAIM PERIOD

Note:

1. Units are advised that expiry of claim period may be kept 3-6 months after validity date. It may be ensured that the same is in line with the agreement/ contract entered with the Vendor.
2. The BG should be on Non-Judicial Stamp paper/e-stamp paper of appropriate value as per Stamp Act prevailing in the State(s) where the BG is submitted or is to be acted upon or the rate prevailing in the State where the BG was executed, whichever is higher. The Stamp Paper/e-stamp paper shall be purchased in the name of Vendor/Contractor/Supplier /Bank issuing the guarantee.
3. In line with the GCC, SCC or contractual terms, Unit may carry out minor modifications in the Standard BG Formats. If required, such modifications may be carried out after taking up appropriately with the Unit/Region's Law Deptt.

4. In Case of Bank Guarantees submitted by Foreign Vendors –

a. From Nationalized/Public Sector / Private Sector/ Foreign Banks (BG issued by Branches in India) can be accepted subject to the condition that the Bank Guarantee should be enforceable in the town/city or at nearest branch where the Unit is located i.e. Demand can be presented at the Branch located in the town/city or at nearest branch where the Unit is located.

b. From Foreign Banks (wherein Foreign Vendors intend to provide BG from local branch of the Vendor country's Bank)

b.1 In such cases, in the Tender Enquiry/ Contract itself, it may be clearly specified that Bank Guarantee issued by **any of the Consortium Banks only** will be accepted by BHEL. As such, Foreign Vendor needs to make necessary arrangements for issuance of Counter- Guarantee by Foreign Bank in favour of the Indian Bank's (BHEL's Consortium Bank) branch in India. It is advisable that all charges for issuance of Bank Guarantee/ counter- Guarantee should be borne by the Foreign Vendor. The tender stipulation should clearly specify these requirements.

b.2 **In case, Foreign Vendors intend to provide BG from Overseas Branch of our Consortium Bank** (e.g. if a BG is to be issued by SBI Frankfurt), the same is acceptable. However, the procedure at sl.no. b.1 will required to be followed.

b.3 The BG issued may preferably be subject to Uniform Rules for Demand Guarantees (URDG) 758 (as amended from time to time). The BG Format provided to them should clearly specify the same.