

BHARAT HEAVY ELECTRICALS LTD., BHOPAL
MATERIAL MANAGEMENT (EM)
PIPLANI – BHOPAL – 462 022 (M.P)
PHONE : + 91 755 250 5785 / 5052
e-mail:- adarshkc@bhel.in, akumar1@bhel.in

OPEN TENDER NOTICE No. : MEX/24-25/E1543114

Tenders in two part bid system are invited for supply of the following items. Complete tender document can be downloaded from BHEL website <http://www.bhel.com> & BHEL e-procurement website <https://eprocurebhel.co.in/nicgep/app>. **The tender should be submitted before 03.00 PM of 20/07/2024 through** BHEL e-procurement website <https://eprocurebhel.co.in/nicgep/app>.

Note :- All enclosures are available on BHEL website <http://www.bhel.com> as well as BHEL e-procurement website <https://eprocurebhel.co.in/nicgep/app> against the above enquiry. Unregistered vendor can download the assessment form for registration from our website.

S. No	Enquiry no.	NIC Tender ID	Item	Qty.	Due date
1	E1543114	2024_BHEL_37552_1	RATING PLATE	8,25,00,000 SQ. MM	20/07/2024
2			TAG PLATE	95,00,000 SQ. MM	
3			SMALL PLATES	9,60,00,000 SQ. MM	

Note:- All subsequent corrigendum/amendment shall be published only on our website <http://www.bhel.com> & BHEL e-procurement website <https://eprocurebhel.co.in/nicgep/app> against the enquiry no. Hence, bidders are advised to be always in touch with our website till the tender is finally opened.

आदर्श कुमार चौधरी
Adarsh Kumar Chowdhary
Manager (MEX)
सा. प्र. - ई. एम. /
बी.एच.ई.एल., भोपाल / BHEL, BHOPAL



ENQUIRY

TWO PART BID

BPC 0007

E-TENDER

भारत हेवी इलेक्ट्रिकल्स लिमिटेड, पिपलानी, भोपाल- ४६२०२२ (भारत)

सामग्री प्रबंधन विभाग

BHARAT HEAVY ELECTRICALS LIMITED, PIPLANI, BHOPAL-462022 (INDIA)
MATERIALS MANAGEMENT DIVISIONTIN NO- 23573000001 ECC NO- AAACB4146PXM009 MPCT NO- HEL/05/01/0001/515/11/79
PHONE NO : 91-755-2500100 FAX : 91-755-2500023 www.bhel.comENQUIRY NO E1543114
ENQUIRY DATE 28/06/24
ENQUIRY DUE DATE 20/07/24

SUPP NAME AND ADDRESS	SUPP CODE	REV CD	REV NO	REV DATE	NO OF CATY2	NO OF CATY3	ENQ NO OF ITEMS	INDENT NO
	0	1	0	NA	3	3	3	221740007
	GUARANTEE CERTIFICATE	Y		SUPPLY CONDITION	IN PROPERLY PACKED CONDITION.			
	TEST CERTIFICATE	Y						
	INSTRUCTION BOOKLET	N		TECHNICAL CONDITION	AS PER DRAWING & SPECIFICATION.			
	SAMPLE	N						
	GATE PASS	Y		INSPECTION CONDITION	BY BHEL AT BHEL BHOPAL.			

NOTE: QUOTE PRICE BOTH IN FIGURES & WORDS. IN CASE OF MISMATCH PRICE IN WORDS WILL BE VALID. QUOTATIONS NOT BEARING ENQUIRY NO AND DUE DATE LIABLE TO BE REJECTED.

SL NO	MATERIAL CODE	DESC	UNIT	ITEM QTY	QTY VR%	LOT NO	LOT QTY	DEST	DELIVERY DATE
1	AM4470637173	RATING PLATE STAINLESS STEEL OF 0.7 MM TK TO REF. DRG.NO - 34021042020, 34021142821, 34021142829, 34021142830, 12992501001 & SIMILAR DRAWINGS TO MATERIAL SPECIFICATION AA10739.	SM	82500000.000	0	1	82500000.000	217	30/07/24
2	AM4441115030	TAG PLATE TO REF. DRG. NO 34021140710, 34021141177 & SIMILAR DRAWINGS TO MATERIAL SPECIFICATION AA10737.	SM	9500000.000	0	1	9500000.000	217	30/07/24
3	AM4400666000	SMALL PLATES TO REF. DRG. 24030040011, AM54164, AM54237, C400672, C400853, 44020542041, 44020542340, 44020542106, 4402004062, 34021042094, AM54222, AM54041 & SIMILAR DRAWINGS TO MATERIAL SPECIFICATION AA10739.	SM	96000000.000	0	1	96000000.000	217	30/07/24
REMARK	[1] THIS IS AN E-PROCUREMENT ENQUIRY & OFFER TO BE SUBMITTED THROUGH NIC PORTAL (HTTPS://EPROCUREBHEL.CO.IN/NICGEP/APP) ONLY. [2] BHEL STD T&C BP200102A, MM5527 [AS AVAILABLE AT HTTPS://BPL.BHEL.COM] ARE APPLICABLE. [3] ALL GST PROVISIONS ARE APPLICABLE. [4] LOCAL CONTENT DECLARATION AS PER ATTACHED FORMAT TO BE SUBMITTED WITH OFFER. [5] PLEASE QUOTE FOR BHEL BHOPAL DOOR DELIVERY BASIS INCLUDING P&F, FREIGHT & INSURANCE CHARGES. [6] THIS IS RATE CONTRACT ENQUIRY. RATE CONTRACT ANNEXURE-A APPLICABLE. SEALED & SIGNED COPY OF SAME TO BE SUBMITTED ALONG WITH OFFER.								
DRAWING	Y	PURCH SPEC	Y	CATALOGUE	N	Quality Surveillance Plan	TWO PART BID	Y	

NOTE: BHEL, BHOPAL'S Standard Terms & Conditions: BP200102 (Latest Revision) form a part of this Enquiry. Bidders may obtain from us copies of these terms and conditions if not already available.

Note: During Bid Evaluation, No loading of price with regard to preferential payment of within 45 days will be made on vendore falling under MSMED ACT - OCT 06

Please submit your lowest quotation in sealed envelop essentially superscribed with ENQUIRY NO, DUE DATE AND PARTY'S NAME so as to reach at TENDER ROOM, GROUND FLOOR, ADM BUILDING, BHEL, PIPLANI BHOPAL-462022 by 11.00 am of due date.

SPECIAL REMARK: Bid to be submitted through e-procurement. Refer eproc link on BHEL Bhopal B2B site.

1. This is only a request for Quotation & not an order.
2. Small Scale industries should indicate SSI Regn. No. in Quotation/invoice.
3. In case you are not making an offer against this Enquiry, we request you to post a regret letter.
4. Indian vendors to please indicate GSTIN on their quotation.

Documents Enclosed

1. Drawing.
2. Catalogue.
3. Purchase specification.
4. Quality Surveillance Plan.

NAME : ADARSH KUMAR CHOWDHARY

DESG : MANAGER

0755-250578

adarshk@bhel.in

SIGN & SEAL

सा. प्र. - ई. एम. / M. M. - E. M.
बी.एच.ई.एल., भोपाल / B.H.E.L., BHOPAL

Techno-Commercial Bid
(To be filled by supplier and submit with offer)

Tender No.		E1543114		
Item Description :		IT.01- RATING PLATE STAINLESS STEEL OF 0.7 MM TK TO REF. DRG.NO - 34021042020, 34021142821,34021142829, 34021142830, 34021142830,12992501001 & SIMILAR DRAWINGS TO MATERIAL SPECIFICATION AA10739. IT.02- TAG PLATE TO REF. DRG. NO 34021140710, 34021141177 & SIMILAR DRAWINGS TO MATERIAL SPECIFICATION AA10737. IT.03- SMALL PLATES TO REF. DRG. 24030040011, AM54164,AM54237, C400672, C400853, 44020542041, 44020542340,44020542106, 4402004062, 34021042094, AM54222, AM54041 & SIMILAR DRAWINGS TO MATERIAL SPECIFICATION AA10739.		
Remarks :		[1] THIS IS AN E-PROCUREMENT ENQUIRY & OFFER TO BE SUBMITTED THROUGH NIC PORTAL (HTTPS://EPROCUREBHEL.CO.IN/NICGEP/APP) ONLY [2] BHEL STD T&C BP200102A, MM5527 [AS AVAILABLE AT HTTPS://BPL.BHEL.COM] ARE APPLICABLE. [3] ALL GST PROVISIONS ARE APPLICABLE. [4] LOCAL CONTENT DECLARATION AS PER ATTACHED FORMAT TO BE SUBMITTED WITH OFFER. [5] PLEASE QUOTE FOR BHEL BHOPAL DOOR DELIVERY BASIS INCLUDING P&F, FREIGHT & INSURANCE CHARGES. [6] THIS IS RATE CONTRACT ENQUIRY. RATE CONTRACT ANNEXURE-A APPLICABLE. SEALED & SIGNED COPY OF SAME TO BE SUBMITTED ALONG WITH OFFER.		
Sr. No.	ELEMENTS	Standards	To be offered / confirmed by supplier	Remarks, if any
1	Quotation Reference & date	As per supplier		
2	HSN / SAC code	As per supplier		
2.1	GST TYPE & ITS PERCENTAGE APPLICABLE Item wise mentioned in the offer (IGST/CGST+SGST/UGST)	As per supplier		
3	Quotation Currency	In INR		
4	E-Mail	As per supplier		
5	Phone/Mobile	As per supplier		
6	Contact Person	As per supplier		
7	Order to be placed on	As per supplier		
8	Address	As per supplier		
9	Minimum delivery period to be quoted in no of days from the date of Purchase Order.	Our requirement within 60 days from PO date		
10	Prices shall be Firm.	Yes		
11	INSPECTION: As given in enquiry.	Yes		
12	Delivery Destination: - The material is required to be supplied to FOR BHEL Bhopal with all freight charges on paid basis.	Yes		
12.1	Price to be furnished on FOR destination BHEL Bhopal, duly insured basis inclusive of P&F charges.	Yes		
13	Quoted for all the items of tender enquiry	Yes / No. (If "No" please mention item number of regretted items)		
14	Technical Specifications	Accepted as per enquiry / Accepted with deviation (If select Accepted with deviation, please mention the deviation)		
15	Guarantee Period of Material as per clause no. 18 of enquiry GTC BP200102A.	Yes		
16	TC , GC and ALL Inspection report as per tender enquiry and specification will be submitted along with each consignment.	Yes (In case of "No" your offer may be rejected).		
17	Brand Name, If any.	As per supplier		
18	Supply from	As per supplier		
19	Quotation Validity will be 90 days from the date of Technical bid opening.	Yes		
20	Are you registered under MSE ACT 2006 as small or micro.	Yes / No (If select Yes, please enclosed latest printed UDYAM certificate)		

Name of Supplier:
Sign and Seal of Supplier

Techno-Commercial Bid (To be filled by supplier and submit with offer)				
Tender No.		E1543114		
Description :		IT.01- RATING PLATE STAINLESS STEEL OF 0.7 MM TK TO REF. DRG.NO - 34021042020, 34021142821,34021142829, 34021142829, 34021142830,12992501001 & SIMILAR DRAWINGS TO MATERIAL SPECIFICATION AA10739. IT.02- TAG PLATE TO REF. DRG. NO 34021140710, 34021141177 & SIMILAR DRAWINGS TO MATERIAL SPECIFICATION AA10737. IT.03- SMALL PLATES TO REF. DRG. 24030040011, AM54164,AM54237, C400672, C400853, 44020542041, 44020542340,44020542106, 4402004062, 34021042094, AM54222, AM54041 & SIMILAR DRAWINGS TO MATERIAL SPECIFICATION AA10739.		
Sr. No.	ELEMENTS	Standards	To be offered/confirmed by supplier	Remarks, if any
21	<p>Payment terms: 100% payment within 90 days of receipt (45 days for MSE / NSIC registered suppliers under as per relevant act in force) subject to acceptance of material at BHEL, on direct presentation of the documents. Any deviation from the above payment terms, if accepted (by BHEL), shall be loaded @ SBI base rate + 6% for the purpose of bid evaluation.</p> <p>Important note: An MSE enterprises who are traders/agent/dealer shall not be benefitted under public procurement. Therefore, no benefit including terms of payment within 45 days shall be passed on to MSE vendor who are trader, dealer and agent. If you are not an "original manufacturer" of indented product against above enquiry, please accept the payment terms as " 100% payment in 90 days after receipt & acceptance of material at BHEL". In case of non-acceptance or any deviation from the above payment terms, if accepted (by BHEL), shall be loaded @ SBI base rate + 6% for the purpose of bid evaluation.</p>	90 days / 45 Days (If supplier is MSE, please select 45 days and if supplier is non -MSE or Trader/Dealer/Agent, please select 90 days)		
22	Other Charges (If any)	Applicable / Not Applicable. (If applicable please mention percentage (%) / Value (along with type of charges).		
23	Transit Insurance will be in supplier scope	Yes		
24	Penalty: - LD penalty shall be 0.5% of the total order value per week of delay or part thereof, subject a maximum of 10% of the total order value. Total order value above shall be item wise, lot wise order value.(Please refer clause 9 of GTC - BP200102A).	Yes / No (In case of "No", your offer will be loaded suitably)		
25	Acceptance of General Terms and Conditions of enquiry (Form No. BP- 200102A) & BHEL P.O. Terms & Conditions (Indigenous) MM5527 (available at B2B site of BHEL Bhopal).	Yes (In case of "No" your offer may be rejected).		
26	Kindly confirm whether other family firms or sister concern affiliates / subsidiary firms are participating in the same tender, so as to eliminate the possibility of cartel formation. (if yes kindly attach filled, sign & sealed copy of Annexure-IX).	Kindly attach 'Annexure -IX' with seal & sign.		
27	Confirm whether bidder is Manufacturer or Trader or Dealer or Agent of items under enquiry. In case of Trader or Dealer or Agent, please furnish authorization certificate from OEM.	As per supplier		
28	I/We hereby certify that the quoted items(s) offered by us in this enquiry is /are having local content (in %) of	As per supplier		
28.1	I/We hereby certify that the local content % certified above is in line with definition of local content given in Public Procurement (Preference to Make in India), Order 2017 Dtd. 4-6-2020 and I/We qualify as (Class-I/Class-II/Non-Local supplier – Fill in one which is applicable).	As per supplier (Class I – Equal to or more than 50%, Class II – More than 20% but less than 50%, Non - Local :Less than or equal to 20%) [NOTE: Please provide Certification regarding local content on your letter head for the quoted items with seal & sign.]		
28.2	Address of location at which the local value addition is made:	As per supplier		
28.3	By filling "Yes" in adjacent Box, I hereby declare & confirm that the details furnished above are true and correct to the best of my knowledge and belief and I undertake to inform you of any changes therein immediately. In case any of the above information is found to be false or untrue or misleading or misrepresenting, I am aware that I may be held liable for it.	Yes / No		

- 1) Deviation in any commercial condition shall be suitably loaded in the offered price.
- 2) In case of any conflict, confirmation by vendor provided here will supersede.
- 3) In case bidder is not making an offer against this enquiry, we request the bidder to post the regret letter

Name of Supplier:.....

Seal & Sign of supplier

ENQUIRY NO. E1543114, DATED 28/06/2024**TERMS AND CONDITIONS FOR RATE CONTRACT FOR RATING PLATE, TAG PLATE & SMALL PLATE**

1. **Duration of Contract:** Rate contract shall be valid for a period of 12 months for ordering from the date of RC agreement date. Rate contract shall be extendable for further periods as per mutual consent.
2. **Delivery:** Our requirement of material is within 60 days from PO date. Drawing wise as per BHEL requirement PO will be placed during the RC period. **Please offer your best possible delivery against our requirement.**
3. All technical requirements should be as per drawing & specification with latest revisions and all dimensions & tolerances should be maintained as per PO requirements.
4. Quantity variation $\pm 20\%$.
5. RC quantity for each item may be distributed between 02 vendors in the ratio of 70:30 at L1 rate. If no other supplier accepts L1 rate then total RC qty. of that item may be given to L1 supplier.
6. **Packing & identification:** Material to be supplied as per drawing & specification & in properly packed condition with identification [PO No., Drg. No., Supplier name] on each plate & pack.
7. **Unit rate for all the items should be quoted separately in "Rs. per Sq. MM".** Rate should be on F.O.R. Destination door delivery basis including transportation, transit insurance, packing & forwarding charges. The taxes / duties shall be payable extra. Applicable rates and HSN code are to be mentioned in your offer.
8. Quoted unit rate will be firm during entire contractual period and PVC will not be applicable. **Offers of bidders with PVC will be rejected.**
9. **Test & Guarantee Certificate:** Test and guarantee certificates shall be submitted for each supply. **In absence of TC & GC material is liable for rejection.**
10. **Order will be placed as per actual order book position of BHEL. Rate contract agreement does not guarantee PO commitment to vendor.**
11. Inspection shall be done by BHEL at BHEL Bhopal.
12. **Payment terms:** 100% within 90 days [45 days for MSE] after receipt and acceptance of material at our works as per BHEL norms. Vendor has to submit latest printed UDYAM certificate for availing benefits under MSE.
13. The offer shall be in two parts viz-
Part I - Technical & Commercial Offer
Part II - Price Offer Only

Both Part - I and Part - II bids should be uploaded on our e-procurement web page before 15.00 Hrs. on due date.
14. **Basis for deciding lowest (L1) offer:**
 - i. Only offers meeting the terms and conditions of the enquiry will be considered.
 - ii. All the offers shall be compared for total cost to BHEL at BHEL stores.
 - iii. *Offers having deviations to the terms and conditions will be suitably loaded or are liable to be rejected.*
15. **Validity of Offer:** Quotation should be valid for a period of **minimum 90 days** from the date of opening of tender.
16. **Penalty:** The delay in delivery would be subject to penalty as per GTC- BP200102A, clause 9.
17. The purchase orders against the Rate Contract will be issued from time to time as per vendor quoted & accepted delivery OR as mutually agreed at the time of issue of PO as per BHEL requirement. The vendors should ensure timely dispatch as per the delivery schedule indicated in the purchase order.

18. BHEL reserves the right to cancel:
 - i. It's requirement of part or full quantity at any stage of the tender finalization or even after finalization of tender.
 - ii. The order(s) if any suppliers(s) found to be "unsatisfactory" during our periodical assessment processes / review of assessment process / non-compliance of statutory requirements etc. as required for "vendor registration" during the execution of order(s).
19. Apart from the above, Terms & conditions of indigenous enquiry and P.O. issued by material management department vide BP 200102A and MM 5527 Rev. 03 respectively / latest revision available at the vendor portal, will also be applicable.
20. **Acceptance of all the above terms & conditions along with General terms and conditions of Enquiry (BP200102A) are required in your offer. The same is to be signed and sealed by all the vendors & uploaded on our EPS along with Part-1 offer.**

(To be signed & affix by vendors
in acceptance of all above points)

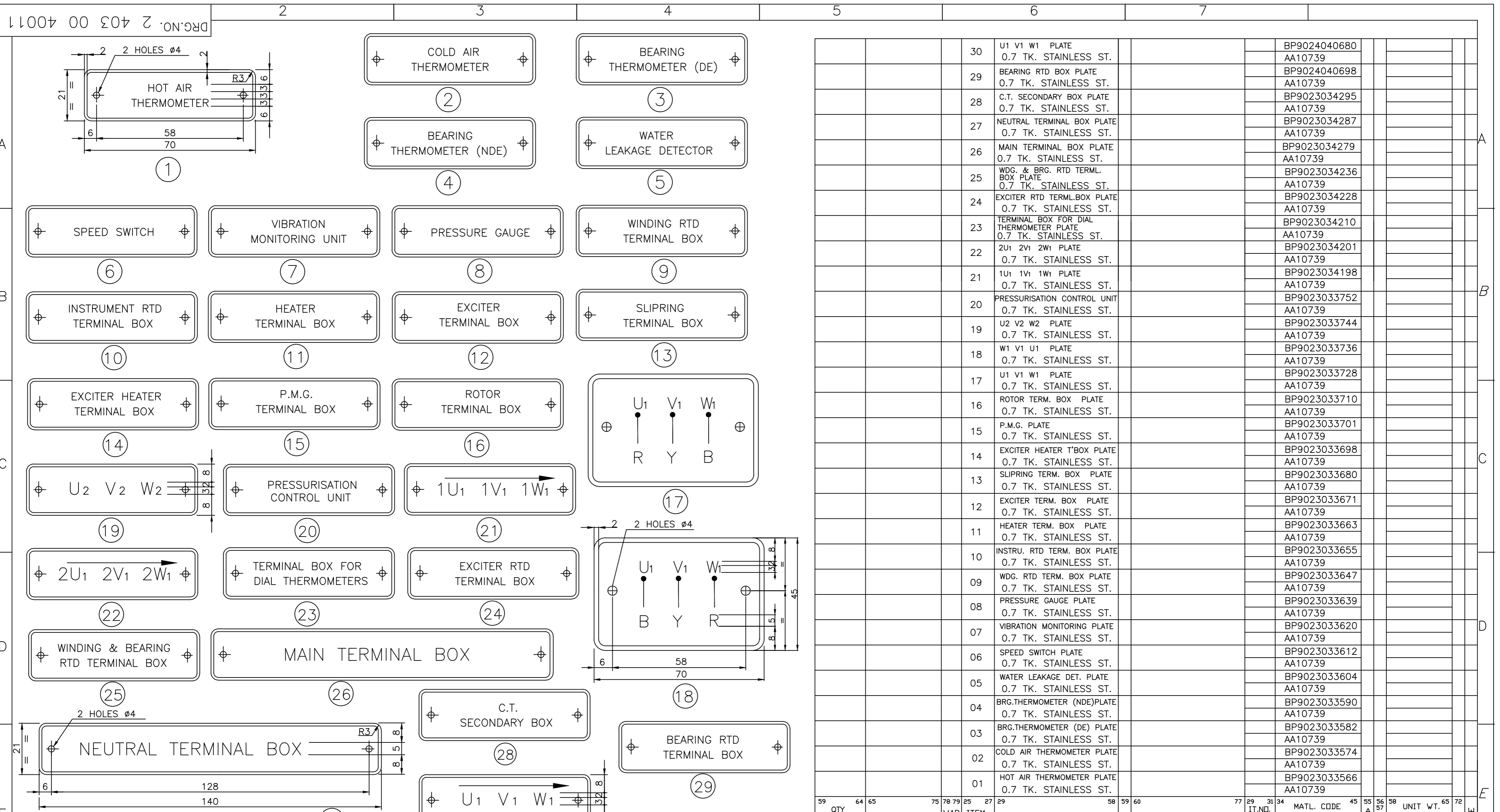

TECHNICAL REQUIREMENTS :-

- FINISH:- STAINLESS STEEL BACK GROUND ENGRAVED WITH LETTERS/LINES ETCHED BLACK. BLACK FINISH SHALL BE WITH STOVING ENAMEL.
- BLUE PRINT OF IDENTIFICATION PLATE TO BE SUBMITTED BY SUPPLIER FOR APPROVAL BEFORE BULK SUPPLY.
- ALL ITEM TO BE MADE SAME AS ITEM 1, EXCEPT ITS.17,18,26,27 & ENGRAVED MATTER.
- LAY OUT FOR ITEMS 16,19,21,22,26,27&30 SHALL BE AS SHOWN IN IT.19. & LAY OUT FOR ITEMS 17 AS PER ITEM 18. LETTER SIZE SHALL BE 5 MM AS PER AA0421403.
- LAY OUT FOR ALL OTHER ITEMS EXCEPT ITEMS 16,17,18,19,21,22,26,27&30 SHALL BE AS SHOWN IN IT. 01 LETTER SIZE SHALL BE 3 MM AS PER AA0421403.

REV.	DATE	ALTERED	Sd/-	REV.	DATE	ALTERED	Sd/-
08	05.06.21	ALTERED P.K.DUBEY	Sd/-	03	3.09.03	ALTERED LDV	Sd/-
		APPROVED AKM	Sd/-			CHECKED AKB	Sd/-
07	20.04.19	ALTERED VINAY	Sd/-	02	18.7.03	ALTERED BRP	Sd/-
		APPROVED USR	Sd/-			CHECKED AKB	Sd/-
06	09.12.14	ALTERED RPB	Sd/-	01	13.8.02	ALTERED LP	Sd/-
		APPROVED DKD	Sd/-			CHECKED RG	Sd/-
						APPROVED SB	Sd/-

QTY	VAR00	REMARKS	VAR	ITEM	DESCRIPTION	STD	DRAWING NO.	IT.ND.	MATL. CODE	UNIT	UNIT WT.	QTY.	ZONE
30					U1 V1 W1 PLATE 0.7 TK. STAINLESS ST.				BP9024040680				
29					BEARING RTD BOX PLATE 0.7 TK. STAINLESS ST.				AA10739				
28					C.T. SECONDARY BOX PLATE 0.7 TK. STAINLESS ST.				BP9024040698				
27					NEUTRAL TERMINAL BOX PLATE 0.7 TK. STAINLESS ST.				BP9023034295				
26					MAIN TERMINAL BOX PLATE 0.7 TK. STAINLESS ST.				AA10739				
25					WDG. & BRG. RTD TERML. BOX PLATE 0.7 TK. STAINLESS ST.				BP9023034279				
24					EXCITER RTD TERML. BOX PLATE 0.7 TK. STAINLESS ST.				AA10739				
23					TERMINAL BOX FOR DIAL THERMOMETER PLATE 0.7 TK. STAINLESS ST.				BP9023034228				
22					2U1 2V1 2W1 PLATE 0.7 TK. STAINLESS ST.				AA10739				
21					1U1 1V1 1W1 PLATE 0.7 TK. STAINLESS ST.				BP9023034210				
20					PRESSURISATION CONTROL UNIT 0.7 TK. STAINLESS ST.				AA10739				
19					U2 V2 W2 PLATE 0.7 TK. STAINLESS ST.				BP9023034201				
18					W1 V1 U1 PLATE 0.7 TK. STAINLESS ST.				AA10739				
17					U1 V1 W1 PLATE 0.7 TK. STAINLESS ST.				BP9023034198				
16					ROTOR TERM. BOX PLATE 0.7 TK. STAINLESS ST.				AA10739				
15					P.M.G. PLATE 0.7 TK. STAINLESS ST.				BP9023033752				
14					EXCITER HEATER T'BOX PLATE 0.7 TK. STAINLESS ST.				AA10739				
13					SLIPRING TERM. BOX PLATE 0.7 TK. STAINLESS ST.				BP9023033744				
12					EXCITER TERM. BOX PLATE 0.7 TK. STAINLESS ST.				AA10739				
11					HEATER TERM. BOX PLATE 0.7 TK. STAINLESS ST.				BP9023033736				
10					INSTRU. RTD TERM. BOX PLATE 0.7 TK. STAINLESS ST.				AA10739				
09					WDG. RTD TERM. BOX PLATE 0.7 TK. STAINLESS ST.				BP9023033728				
08					PRESSURE GAUGE PLATE 0.7 TK. STAINLESS ST.				AA10739				
07					VIBRATION MONITORING PLATE 0.7 TK. STAINLESS ST.				BP9023033710				
06					SPEED SWITCH PLATE 0.7 TK. STAINLESS ST.				AA10739				
05					WATER LEAKAGE DET. PLATE 0.7 TK. STAINLESS ST.				BP9023033701				
04					BRG.THERMOMETER (NDE)PLATE 0.7 TK. STAINLESS ST.				AA10739				
03					BRG.THERMOMETER (DE) PLATE 0.7 TK. STAINLESS ST.				BP9023033698				
02					COLD AIR THERMOMETER PLATE 0.7 TK. STAINLESS ST.				AA10739				
01					HOT AIR THERMOMETER PLATE 0.7 TK. STAINLESS ST.				BP9023033680				

REV. 05	DATE 08.02.11	ALTERED CHECKED APPROVED	Sd/-	REV. 04	DATE 1.06.04	ALTERED BLP CHECKED APPROVED	Sd/-	REV. 03	DATE 3.09.03	ALTERED LDV CHECKED APPROVED	Sd/-	REV. 02	DATE 18.7.03	ALTERED BRP CHECKED APPROVED	Sd/-	REV. 01	DATE 13.8.02	ALTERED LP CHECKED APPROVED	Sd/-
IMM & TEX(IMM) ADDED.				DESCRIPTION OF ITEMS 15&16 WERE EXCHANGED.				ITEMS 26 TO 28 ADDED. DRG.UPDATED & REDRAWN.				2 HOLES SIZE $\phi 4$ WAS $\phi 2.6$. DIMS. 6 & 58 WERE 5 & 60 RESP.				ITEMS 21-25 ADDED. 2-HOLES SIZE $\phi 4$ WAS $\phi 2.6$. DIMS. 6 & 58 WERE 5 & 60 RESP.			
<p>DEPT. AME</p> <p>CODE 404</p> <p>SCALE</p> <p>WEIGHT(Kg.)</p> <p>REF. TO ASSY. DRG.</p> <p>ITEM NO.</p> <p>75 77 ND. OF ITEMS</p>										<p>STANDARD</p> <p>BHARAT HEAVY ELECTRICALS LTD. BHOPAL</p> <p>DRN PANKAJ -SD- 29/05/01</p> <p>CHD. MRS -SD- 29/05/01</p> <p>APPD. VA -SD- 29/05/01</p> <p>TITLE IDENTIFICATION PLATES</p> <p>DRAWING NO. 2 403 00 40011</p> <p>SHEET NO. 01 NO. OF SHEETS 01</p>									

INVENTORY NO. SIGN & DATE REF. DRG. NO. THE INFORMATION ON THIS DOCUMENT IS THE PROPERTY OF BHARAT HEAVY ELECTRICALS LIMITED. IT MUST NOT BE USED DIRECTLY OR INDIRECTLY IN ANY WAY DETRIMENTAL TO THE INTEREST OF THE COMPANY.

LDV/OGA/24030040011

FIRST ANGLE PROJECTION

(ALL DIMENSIONS ARE IN mm)

DRG. NO. 34021042020

NOTES:-

- RATING PLATE TO BE BOUGHT OUT. BLUE PRINTS OF RATING PLATE TO BE SUBMITTED BY SUPPLIER FOR OUR APPROVAL BEFORE BULK SUPPLY.
- HINDI LETTERING TO BE TO CORP. STD. AA042.14.02 SIZE 2mm UNLESS OTHERWISE STATED.
- ENGLISH LETTERING TO BE TO CORP. STD. AA042.14.03 SIZE 2mm UNLESS OTHERWISE STATED.
- BHEL MONOGRAM (WITHOUT BORDER) TO BE TO CORP. STD. AA040.11.21, SIZE 25.
- FINISH- STAINLESS STEEL BACKGROUND (BUFFED) ENGRAVED WITH LETTERS/LINES ETCHED BLACK.
- BLACK FINISH SHALL BE WITH STOVING ENAMEL.

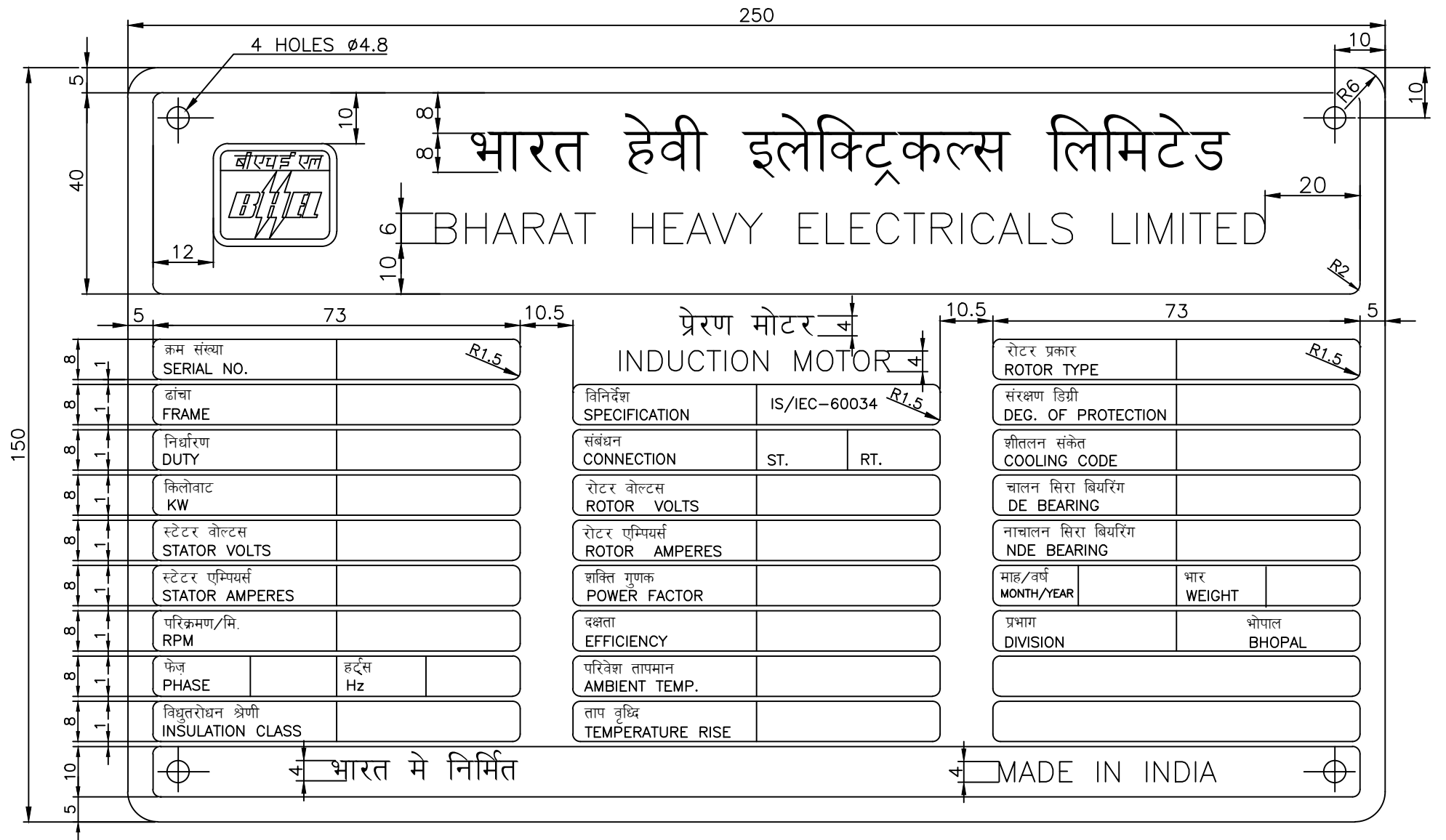

01		01	RATING PLATE STAINLESS STEEL 0.7TK.		BP9023028180		
VAR 00	REMARKS	VAR NO.	ITEM NO.	DESCRIPTION	STD.	DRAWING NO.	ZONE

ADDITION INFORMATION STANDARD	TYPE OF PRODUCT OR STANDARD
STATUS OF DRAWING	NAME OF CUSTOMER/PROJECT
DISTRIBUTION OF PRINT O.C.- 1 IMM- 3 PLM- 3 TEX(IMM)- 1 TEX(PLM)- 1	BHARAT HEAVY ELECTRICALS LTD. BHOPAL

REV 08	DATE 26.06.21	ALTERED CHECKED J.K.	K.N.P.	REV 07	DATE 31.07.15	ALTERED CHECKED J.K.	UPENDRA	REV 06	DATE 24.4.03	ALTERED CHECKED J.K.	SPV	DEPT. AME	GRADE OF UNTOL. DIM. C/M/F	SCALE NTS	WEIGHT (kg)	REF. TO ASSY. DRG.	ITEM NO.	REV. 08	
SPECIFICATION CHANGED.				BLOCK FOR YEAR UPDATED. MONTH ADDED.				IN DISTRIBUTION OF PRINT- IMM & TEX(IMM) ADDED.				TITLE RATING PLATE				DRAWING NO. 34021042020			
												SHEET NO. 01				NO. OF SHEET 01			

THE INFORMATION ON THIS DOCUMENT IS THE PROPERTY OF BHARAT HEAVY ELECTRICALS LIMITED. IT MUST NOT BE USED DIRECTLY OR INDIRECTLY IN ANY WAY DETRIMENTAL TO THE INTEREST OF THE COMPANY.

REF. DRG. NO.

SIGN. & DATE

INVENTORY NO.

LP/GASSY/32102020

SIZE A3

DRG. NO. 34021042094

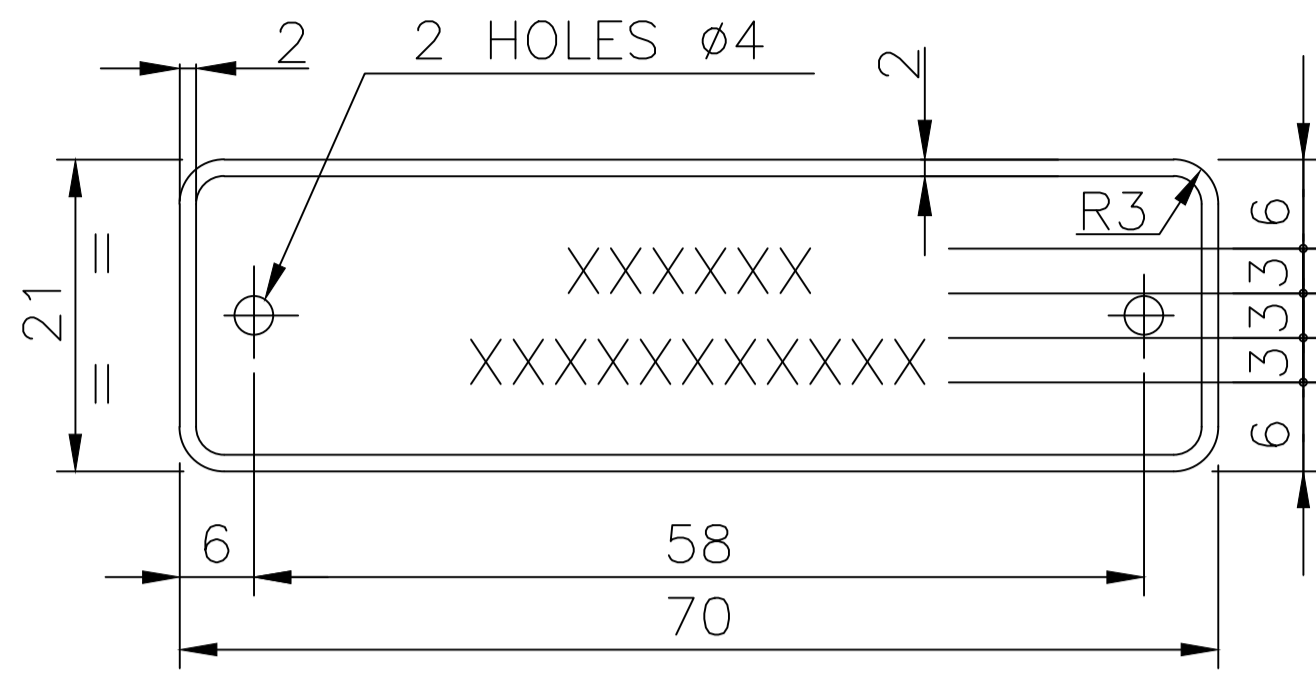

01

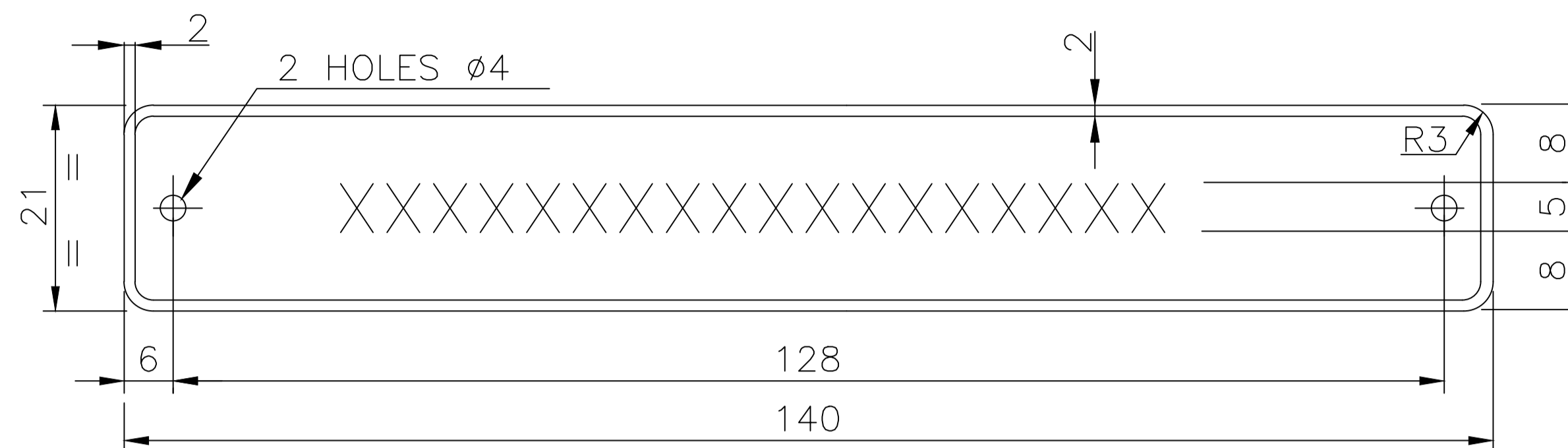

03

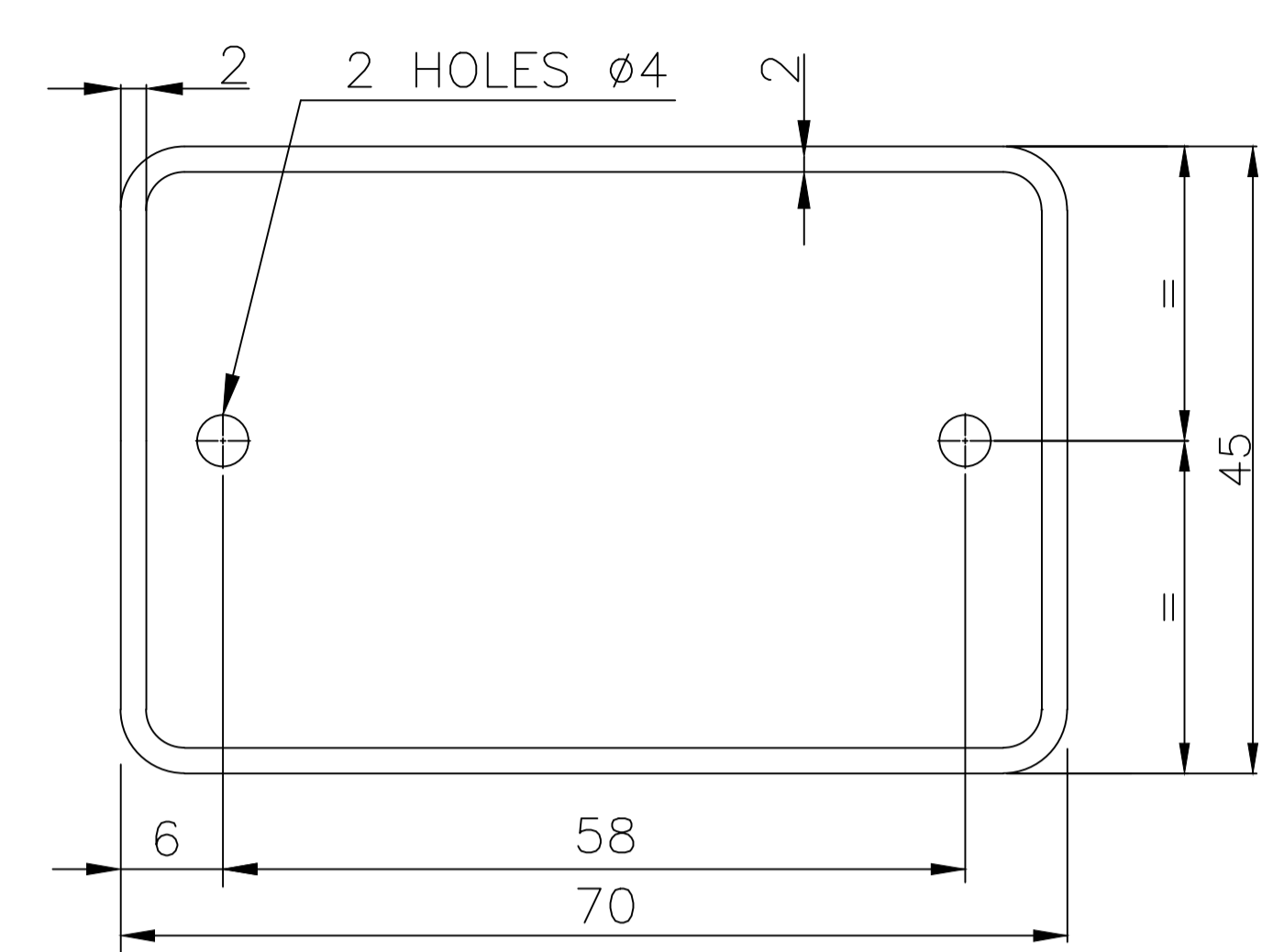

04

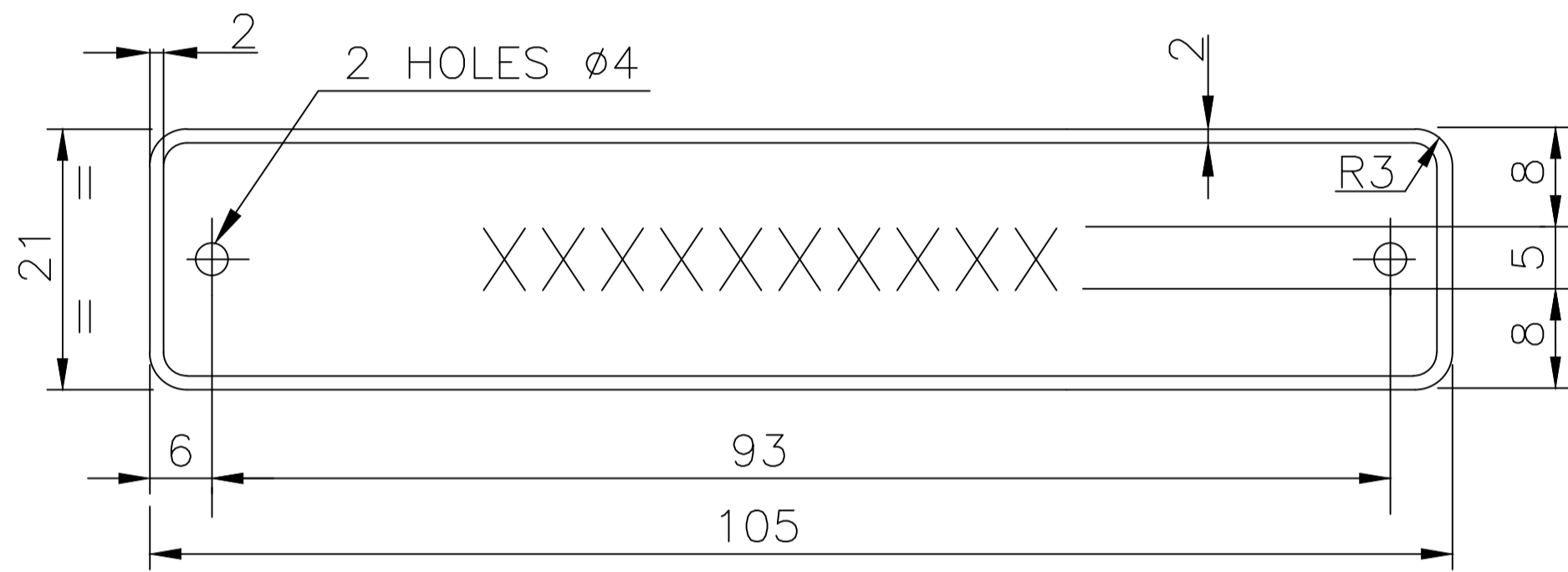

02

TECHNICAL REQUIREMENTS:-

- LETTERS & BORDER SHALL BE BOLD & ETCHED BLACK WITH NATURAL FINISHED BUFFED BACK GROUND.
- IN FIGURE, INSCRIPTIONS SHOWN FOR DIMENSIONAL PURPOSE ONLY. IDENTIFICATION/TAG NO. TO BE ENGRAVED AS PER SPECIFIC REQUIREMENT.

01			04	IDENTIFICATION PLATE 0.7TK. X 45 X 70				BP9023037588																	
								AA10739																	
01			03	IDENTIFICATION PLATE 0.7TK. X 21 X 140				BP9023037570																	
								AA10739																	
01			02	TAG PLATE 0.7TK. X 21 X 105				BP9023037561																	
								AA10739																	
01			01	TAG PLATE 0.7TK. X 21 X 70				BP9023037553																	
								AA10739																	
59	64	65	75	78	79	25	27	29	58	59	60	77	[29-51] [IT.NO.]	34	MATL. CODE	45	55-57 A	58	UNIT WT.	65	72				
VAR 00			REMARKS	VAR NO.	ITEM NO.		DESCRIPTION	STD.	DRAWING NO.				VAR	32	MATL. SPCN.	46	54	C	UNIT	[66-71] QTY.	GS	ZONE			
28			CARD TYPE-3					28			CARD TYPE-1					28					CARD TYPE-2				

THE INFORMATION ON THIS DOCUMENT IS THE PROPERTY OF BHARAT HEAVY ELECTRICALS LIMITED. IT MUST NOT BE USED DIRECTLY OR INDIRECTLY IN ANY WAY DETRIMENTAL TO THE INTEREST OF THE COMPANY.

34021141293
REF. DRG. NO.

SIGN. & DATE

INVENTORY NO.

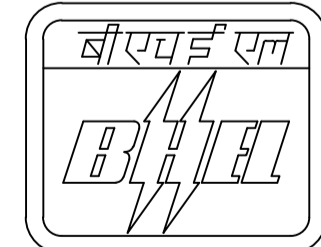
ADDITION INFORMATION				STANDARD				TYPE OF PRODUCT OR NAME OF CUSTOMER/PROJECT				STANDARD																							
STATUS OF DRAWING				DISTRIBUTION OF PRINT				 BHARAT HEAVY ELECTRICALS LTD. BHOPAL				DRN		NAME		SIGN		DATE		73 NO. OF VAR															
AME- 1				TEX- 4								CKD		AJAY		Ajay		10.07.23																	
												APPD		VP		VP		10.07.23																	
REV	DATE	ALTERED	REV	DATE	ALTERED	REV	DATE	ALTERED	REV	DATE	ALTERED	REV	DATE	ALTERED	REV	DATE	ALTERED	REV	DATE	ALTERED	REV	DATE													
		CHECKED			CHECKED			CHECKED	01	25.08.23	CHECKED			CHECKED			CHECKED			CHECKED															
		APPROVED			APPROVED			APPROVED			APPROVED			APPROVED			APPROVED			APPROVED															
				STYLE NUMBERS ADDED.				DEPT. AME				GRADE OF UNTOL. DIM. C/M/F				SCALE N.T.S.				WEIGHT (kg)				REF. TO ASSY. DRG.				ITEM NO.				75 NO. OF ITEMS			
								CODE 404				TITLE IDENTIFICATION AND TAG PLATES				DRAWING NO. 34021042094				22				23				24							
																SHEET NO. 01				NO. OF SHEET 01															

SINGH/VP/34021042094

DRG. NO. 34021142830

THE INFORMATION ON THIS DOCUMENT IS THE PROPERTY OF BHARAT HEAVY ELECTRICALS LIMITED. IT MUST NOT BE USED DIRECTLY OR INDIRECTLY IN ANY WAY DETRIMENTAL TO THE INTEREST OF THE COMPANY.



भारत हेवी इलेक्ट्रिकल्स लिमिटेड

BHARAT HEAVY ELECTRICALS LIMITED

प्रेरण मोटर

INDUCTION MOTOR

क्रम संख्या SERIAL NO.	SEE NOTE 2		
ढांचा FRAME	1MJ7564-2		
निर्धारण DUTY	CONTINUOUS		
किलोवाट KW	400		
स्टेटर वोल्टस STATOR VOLTS	6600		
स्टेटर एम्पियर्स STATOR AMPERES	42		
परिक्रमण/मि. RPM	2969		
फेज PHASE	3	हर्ट्ज Hz	50
विद्युत् रोधन श्रेणी INSULATION CLASS	F		

विनिर्देश SPECIFICATION	IS/IEC60079-1		
संबंधन CONNECTION	ST.	人	RT. -
रोटर वोल्टस ROTOR VOLTS	-		
रोटर एम्पियर्स ROTOR AMPERES	-		
शक्ति गुणक POWER FACTOR	0.89		
दक्षता EFFICIENCY	94.0%		
परिवेश तापमान AMBIENT TEMP.	46°C		
ताप वृद्धि TEMPERATURE RISE	74°C		

रोटर प्रकार ROTOR TYPE	CAGE		
संरक्षण डिग्री DEG. OF PROTECTION	IP55		
शीतलन संकेत COOLING CODE	IC 511		
चालन सिरा बियरिंग DE BEARING	NU220M+6220C3		
नाचालन सिरा बियरिंग NDE BEARING	NU216M		
माह/वर्ष MONTH/YEAR	SEE NOTE-1	भार WEIGHT	5300 Kg.
प्रभाग DIVISION	भोपाल BHOPAL		

भारत में निर्मित

MADE IN INDIA

- RATING PLATE DRG. NO. 34021042020 TO BE DOUBLE ENGRAVED AS SHOWN IN 3mm LETTERS AND FILLED WITH BLACK.
- FOR M/C SERIAL NO. 01,02,03 ETC. TO BE SUFFIXED TO W.O.NO. AS APPLICABLE.
- YEAR OF DESPATCH TO BE ENGRAVED AS APPLICABLE ie. --/ 2021 etc.

01	01	RATING PLATE	34021042020	01	BP9023028180																	
59	64	65	75	78	79	25	27	29	58	59	60	77	29	31	34	45	55	56	57	58	65	72
VAR 01	REMARKS		VAR. NO.	ITEM NO.	DESCRIPTION	STDL.	DRAWING NO.	IT. NO.	MATL. CODE	A	C	UNIT	UNIT WT.	QTY.	ZONE							

INVENTORY NO. SIGN. & DATE REF. DRG. NO.

ADDITIONAL INFORMATION
W.O. NO.- 40113A407-21

TYPE OF PRODUCT :- SQ CAGE INDUCTION MOTOR DRIVE : PUMP
NAME OF CUSTOMER :- M/S IIT CORPORATION INDIA PVT. LTD.
NAME OF PROJECT :- -

DISTRIBUTION OF PRINTS
AME-1

DRN.	NAME	SIGN.	DATE	73	74
CHD.	YM	-Sd-	15.02.21	NO.	OF
APPD.	RAVI	-Sd-	15.02.21	VAR.	
	BSR	-Sd-	15.02.21		

DEPT.	GRADE OF UN. TOL.	SCALE	WEIGHT (Kg.)	REF. TO ASSY. DRG.	NO.	75	77
AME	DIM. C/M/F	NTS				NO.	OF
CODE 404						ITEMS	

TITLE	1	3	7	22	23	24
RATING PLATE	CARD	REV	DRAWING NO.	NO.	OF	REV
	CODE		34021142830	01	OF	00
			SHEET NO. 01	NO. OF SHEETS	01	

FIRST ANGLE PROJECTION

(ALL DIMENSIONS ARE IN mm.)

REV.	DATE	ALTD. - K.N.P.	REV.	DATE	ALTD. - K.N.P.	ADDITIONAL INFORMATION
02	31.07.21	CHKD. - J.K.	01	06.06.15	CHKD. - J.K.	STD.
		APPD. - J.K.			APPD. - J.K.	STATUS OF DRAWING
SERVOPLEX LC-3 WAS SERVOPLEX 3.			SERVOPLEX-3 WAS SERVOGEM-3.			DISTRIBUTION OF PRINTS
						AME - 1

LUBRICATION INSTRUCTION PLATE
 STYLE NO.- BP9024030170 FOR ITEM-01

ALL DIMENSIONS ARE IN mm.

SIZE- 0.7x45x105

ITEM	MATERIAL
01	AA10737
02	SS 316 AS PER ISO 3506/BS1501-3

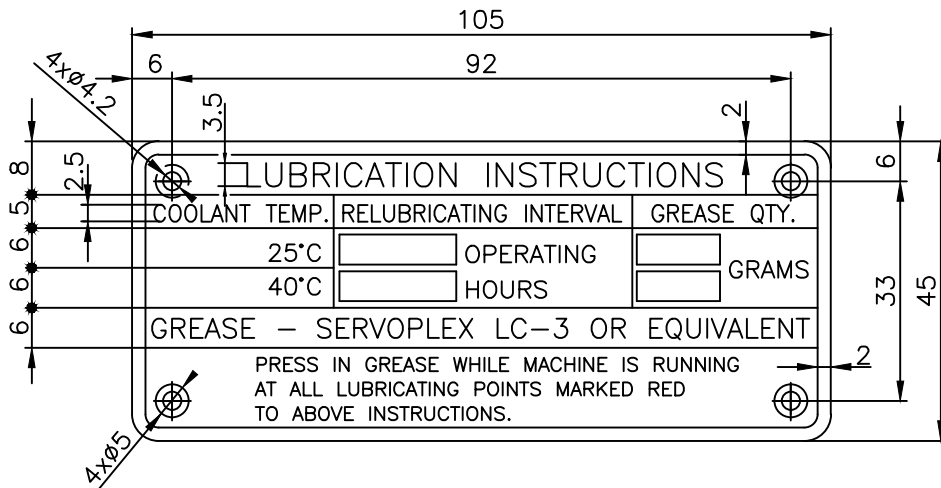

NOTES :-

1. TO BE BOUGHTOUT IN LINE WITH AA0401601.
2. LETTERS BORDER, DIVIDING LINES & PADS SHALL BE RAISED NATURAL FINISHED BUFFED WITH BACKGROUND ETCHED BLACK.

REF. DRG. NO. AM54041

SIGN & DATE



BHARAT HEAVY ELECTRICALS LTD.
 BHOPAL

	NAME	SIGN.	DATE	NO. OF ITEM
DRN	Y.MAHAJAN	-sd-	03.07.13	
CHD	J.K.	-sd-	03.07.13	
APPD	J.K.	-sd-	03.07.13	

INVENTORY NO.

DEPT. AME	UNTOL DIMS GR.		SCALE NTS	WEIGHT(KG.)	REF. TO ASSY. DRG. AM54041	ITEM NO. 00	NO. OF ITEM
CODE 404					DRAWING NO. 4 402 05 42041		REV 02
TITLE LUBRICATION INSTRUCTION PLATE					SHEET NO. 01	NO. OF SHEETS 01	

THE INFORMATION ON THIS DOCUMENT IS THE PROPERTY OF BHARAT HEAVY ELECTRICALS LIMITED IT MUST NOT BE USED DIRECTLY OR INDIRECTLY IN ANY WAY DETRIMENTAL TO THE INTEREST OF THE COMPANY.

FIRST ANGLE PROJECTION

(ALL DIMENSIONS ARE IN mm.)

REV.	DATE	ALTERED	REV.	DATE	ALTERED	ADDITIONAL INFORMATION
		CHECKED			CHECKED	
		APPROVED			APPROVED	
						STD.
						STATUS OF DRAWING
						DISTRIBUTION OF PRINTS
						AME-1 IMM-3
						PLM-3 TEX(IMM)-1

THE INFORMATION ON THIS DOCUMENT IS THE PROPERTY OF BHARAT HEAVY ELECTRICALS LIMITED IT MUST NOT BE USED DIRECTLY OR INDIRECTLY IN ANY WAY DETRIMENTAL TO THE INTEREST OF THE COMPANY.

(STYLE NO. BP 9024034450)
(FOR IT-01)

MATERIAL :- AA10737
0.7X18X52

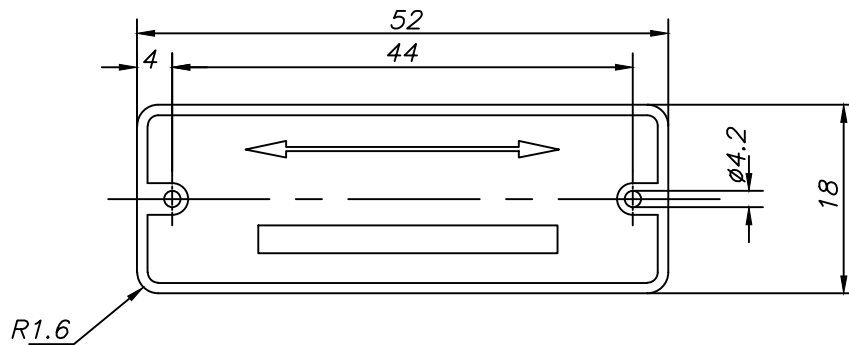

ITEM	MATERIAL
01	AA10737
02	SS 316 AS PER ISO 3506 IBS ISO1-3

NOTE:-

- BOUGHT OUT IN LINE WITH AA0401601
- BORDER ARROW & PAD SHALL BE RAISED
NATURAL FINISHED & BUFFED WITH BACK
GROUND ETCHED BLACK.

AM 54106
REF. DRG. NO.

SIGN & DATE

	BHARAT HEAVY ELECTRICALS LTD.		DRN	YASMIN	SIGN.	DATE	NO. OF ITEM
	BHOPAL		CHD	PANKAJ		04.06.13	
			APPD	AKM		04.06.13	

INVENTORY NO.

DEPT. AME	UNTOL DIMS GR.		SCALE NTS	WEIGHT(KG.)	REF. TO ASSY. DRG.	ITEM NO.	NO. OF ITEM
CODE 404					-	00	
TITLE					DRAWING NO.	REV	
ROTATION PLATE (BIDIRECTIONAL)					44020542106	00	
					SHEET NO.	1	NO. OF SHEETS
						1	

FIRST ANGLE PROJECTION

(ALL DIMENSIONS ARE IN mm.)

REV.	DATE	ALTD. -	REV.	DATE	ALTD. -	ADDITIONAL INFORMATION
		CHKD. -			CHKD. -	
		APPD. -			APPD. -	
						W.O. - 44016A410-11
						STATUS OF DRAWING
						DISTRIBUTION OF PRINTS
						AME - 1 , IMM - 3
						TEX(IMM)-1

IDENTIFICATION NAME PLATE

ALL DIMENTIONS ARE IN MM

MATL:- AA 10737

0.7x20x50

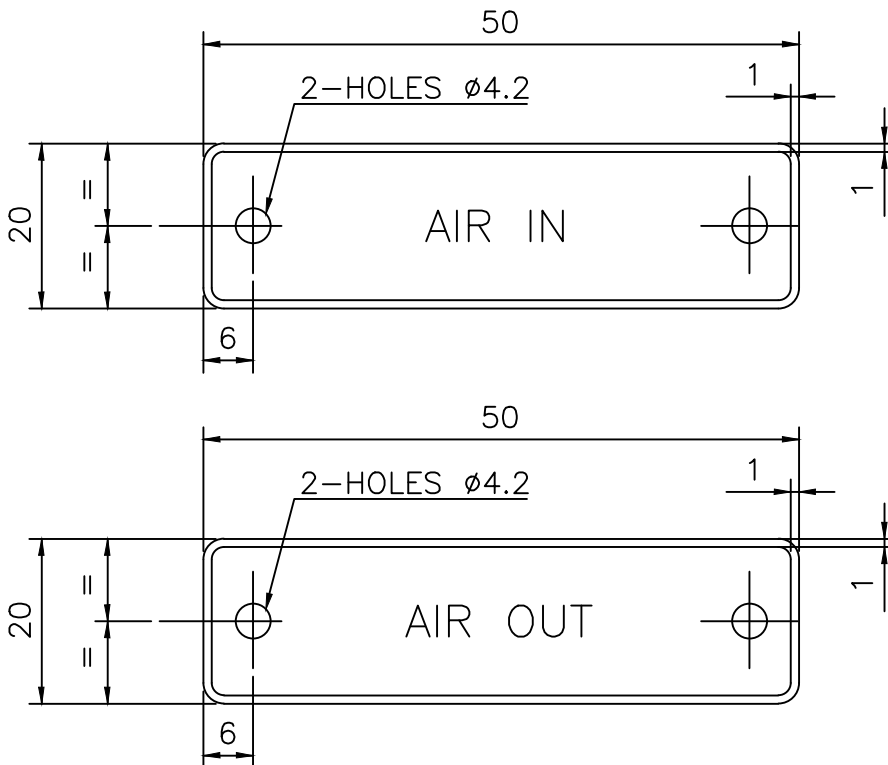

NOTES :-

1. TO BE BOUGHT OUT IN LINE WITH AA 040 16 01.
2. LETTERING TO BE TO AA0401403 SIZE 5.0 mm. UNLESS OTHERWISE STATED.
3. FINISH STAINLESS STEEL BACKGROUND (BUFFED) WITH LETTERS ETCHED BLACK.

THE INFORMATION ON THIS DOCUMENT IS THE PROPERTY OF BHARAT HEAVY ELECTRICALS LIMITED IT MUST NOT BE USED DIRECTLY OR INDIRECTLY IN ANY WAY DETRIMENTAL TO THE INTEREST OF THE COMPANY.

REF. DRG. NO.

SIGN & DATE

INVENTORY NO.

	DRN	NAME	SIGN.	DATE	NO. OF ITEM	
	CHD	K.N.P.		13.12.14		
	APPD	J.K.		13.12.14		
DEPT. AME	UNTOL DIMS GR.	SCALE NTS	WEIGHT(KG.)	REF. TO ASSY. DRG.	ITEM NO.	NO. OF ITEM
CODE 404				-	-	
TITLE				DRAWING NO.	REV.	
IDENTIFICATION NAME PLATE				44020542340	00	
			SHEET NO. 01	NO. OF SHEETS 01		

FIRST ANGLE PROJECTION

(ALL DIMENSIONS ARE IN mm)

THE INFORMATION ON THIS DOCUMENT IS THE PROPERTY OF BHARAT HEAVY ELECTRICALS LIMITED. IT MUST NOT BE USED DIRECTLY OR INDIRECTLY IN ANY WAY DETRIMENTAL TO THE INTEREST OF THE COMPANY.

REV	DATE	ALTERED	AJAY	REV	DATE	ALTERED	UPENDRA	ADDITION INFORMATION
07	11.01.21	CHECKED		05	28.04.17	CHECKED		STD.
		APPROVED	USR			APPROVED	MN/USR	STATUS OF DRAWING
DATA UPDATED.				REDRAWN AND UPDATED				DISTRIBUTION OF PRINT
								AME-01 PLM-04 TEX(PLM)-01

NOTES:-

1. FINISH STAINLESS STEEL BACK GROUND ENGRAVED WITH LETTERS/LINES ETCHED BLACK. BLACK FINISH SHALL BE WITH STOVING ENAMEL.
2. ENGLISH LETTER 3mm SIZE TO AA0421403 HINDI LETTER 3mm SIZE TO AA0421402.

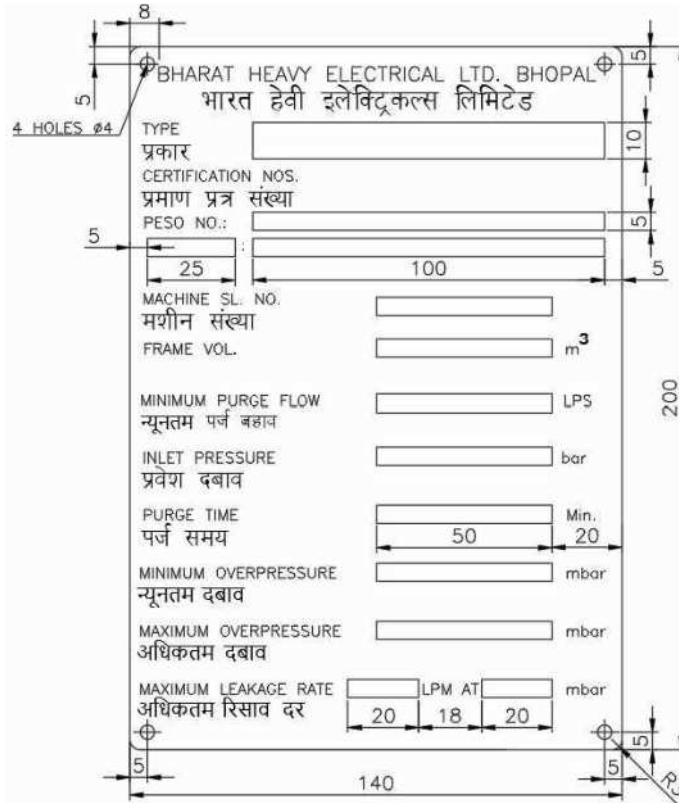

3. BLUE PRINT ON INSTRUCTION PLATE TO BE SUBMITTED BY SUPPLIER FOR OUR APPROVAL BEFORE BULK SUPPLY.

REF. DRG. NO.	01		INSTRUCTION PLATE		AA10739			
	0.7TK.							
REMARKS	ITEM NO.	DESCRIPTION	STD.	MATL. CODE		UNIT WT.		
				MATL. SPCN.		QTY.		
CARD TYPE-3		CARD TYPE-1		CARD TYPE-2				
SIGN. & DATE	 BHARAT HEAVY ELECTRICALS LTD. BHOPAL			DRN	NAME	SIGN	DATE	73 NO. OF VAR
				CKD	R P GERA	-Sd/-	03.07.98	
				APPD	SB	-Sd/-	03.07.98	
INVENTORY NO.	DEPT.	GRADE OF UNTOL.	SCALE	WEIGHT (kg)	REF. TO ASSY. DRG.		ITEM NO.	75 NO. OF ITEMS
	AME	DIM. C/M/F	1:1	--				
TITLE					DRAWING NO.		REV.	
INSTRUCTION PLATE FOR PRESSURIZATION DATA					44031042048		07	
SHEET NO.				NO. OF SHEET				

SIZE A4

P3-1-2

L035449 BL.1 P3-1-2

PRODUCT STANDARD
AME BHOPAL

AM5 4040

1 1

PLATE FOR BRUSH LIFTER

ALL DIMENSIONS ARE IN mm

MATERIAL: AA107 37

0.7x18x52

NOTES:-

- BOUGHT OUT IN LINE WITH AA 040 16 01
- LETTERS, BORDER & ARROW SHALL BE RAISED & NATURAL FINISHED & BUFFED WITH 8% CK GROUND ETCHED BLACK.
- LETTERING TO BE TO STD. AA 042 14 03 SIZE 3mm UNLESS OTHERWISE STATED.

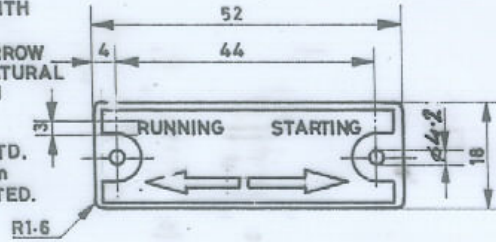

APPROVED BY: [Signature] DATE: 22.11.97

REV 01

04.2 WAS 26. [Signature] On 22.11.97

DISTRIBUTION

AME
IMM
CX (MM)

01
03
02

APPROVED [Signature] 24/3/84

PREPARED [Signature]

S.R.VERMA.

ISSUED

DATE

24/3/84



PRODUCT STANDARD
AME BHOPAL

P3-7-11
AM54164

PAGE 1 OF 1

CAUTION PLATE
FOR INSULATED BEARING
(STYLE NO.9024035317 FOR 17-01)

ALL DIMENSIONS ARE IN mm

Size- 0.7x20x100

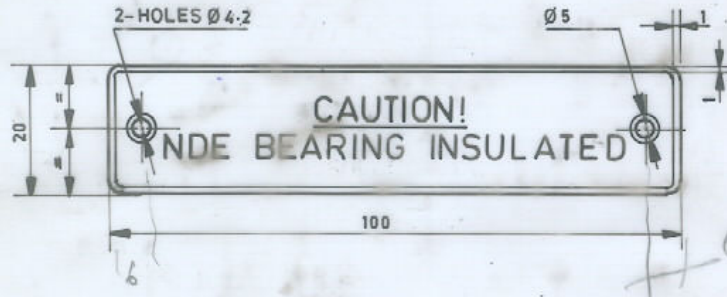

NOTES:-

1. TO BE BOUGHT OUT IN LINE WITH AA 04016 01
2. LETTERING TO BE TO AA 040 14 SIZE mm
3. LETTERS & BORDER SHALL BE RAISED, NATURAL FINISHED & BUFFED WITH BACK GROUND ETCHED RED

ITEM	MATERIAL
01	AA10737 (9024035317)
02	SS 316 AS PER ISO 3506 BS 1501-3

COPYRIGHT AND CONFIDENTIAL
 The information on this document is the property of BHARAT HEAVY ELECTRICALS LIMITED.
 It must not be used directly or indirectly in any way detrimental to the interest of the company.

REVISION	DESCRIPTION	DISTRIBUTION	QTY	APPROVAL	PREPARED	ISSUED	DATE
01	DIMENSIONS ADDED						
02	BB, Ø4.2 WERE Ø4.65, Ø3.17 18-11-97	AME	1	 APPROVAL			
03	ST. NO. CHANGED IN 12 DIGITS	IMM	3				
04	LTEN 02 ADDED	TEX (IMM)	1				
					(S.P. VERMA)	AME DIVN	29/04/92



PRODUCT STANDARD
AME BHOPAL

AM 54222 ^{REV 03}
PAGE 01 OF 01

CAUTION PLATE
(FOR HEATER)

ALL DIMENSIONS ARE IN mm.

ITEM	MATERIAL
01	AA10737(ST. NO.-BP9024037174)
02	SS 316 AS PER ISO 3506 /BS 1501-3

SIZE 0.7 X 25 X 105

NOTE:-

1. TO BE BOUGHT OUT IN LINE WITH AA0401601.
2. LETTERING TO BE TO AA0401403 SIZE 3 mm UNLESS OTHERWISE STATED.
3. LETTERS AND BORDER SHALL BE RAISED NATURAL FINISHED AND BUFFED WITH BACK GROUND ETCHED RED.

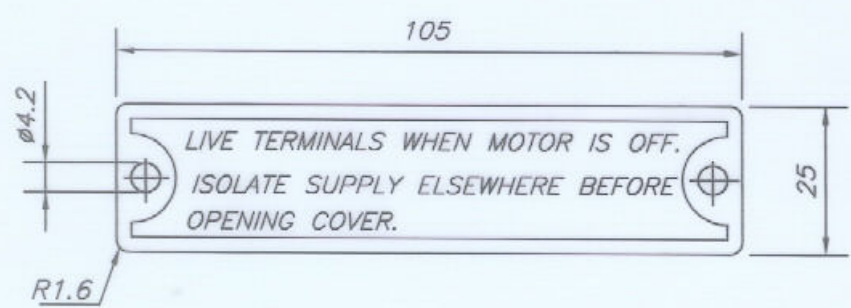

CONFIDENTIAL AND COPYRIGHT THE INFORMATION ON THIS DOCUMENT IS THE PROPERTY OF BHARAT HEAVY ELECTRICALS LIMITED IT MUST NOT BE USED DIRECTLY OR INDIRECTLY IN ANY WAY DETRIMENTAL TO THE INTEREST OF THE COMPANY

REVISIONS	01	DIM 105,25 WERE 74,18 RESPECTIVELY.	DISTRIBUTION	NO	PREPARED	CHECKED	APPROVED
		02	DIM.97 AND 4 WERE NOT ON.	AME			
	03	ITEM 02 ADDED <i>दिलवा कर को 03</i>	IMM	3	-sd-	-sd-	-sd-
			TEX(IMM)	1			



PRODUCT STANDARD
AME BHOPAL

AM54237 REV -

PAGE 1 OF 1

P3-

CAUTION PLATE
FOR INSULATED BEARING

ALL DIMENSIONS ARE IN mm.

MATL:-AA10737
0.7x20x100

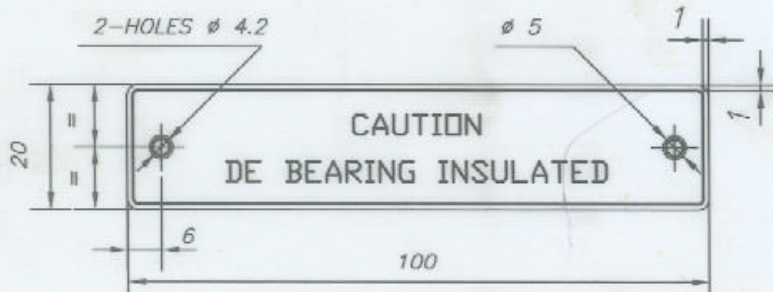

NOTES :-

1. TO BE BOUGHT OUT IN LINE WITH AA 0401601.
2. LETTERING TO BE TO AA 04201403 SIZE 5 mm.
3. LETTERS & BORDER SHALL BE RAISED, NATURAL FINISHED & BUFFED WITH BACK GROUND ETCHED RED.

CONFIDENTIAL AND COPYRIGHT THE INFORMATION ON THIS DOCUMENT IS THE PROPERTY OF BHARAT HEAVY ELECTRICALS LIMITED IT MUST NOT BE USED DIRECTLY OR INDIRECTLY IN ANY WAY DETRIMENTAL TO THE INTEREST OF THE COMPANY

AM54237	REVISIONS	DISTRIBUTION NO		NAME	SIGN	DATE
		AME	1			
		IMM	4			
		TEX(IMM)	1	PREPARED	DIVYA	19.11.01
		PLM	4	CHECKED	JC GUPTA	19.11.01
		TEX(PLM)	1	APPROVED	P. B.	20.11.01

Letter head of Company (<Rs. 10 Cr value)

Ref.

Date

To

Bharat Heavy Electricals Limited
Piplani, Bhopal-462022

Subject: - Certification regarding local content

Reference: Tender Enquiry No-.....

Name of item(s):

Dear Sir,

We hereby certify that the quoted items offered by us against Enquiry No
is having local content of%.

Further, to certify that the local content % certified above is in line with definition of Local content given in point no 2 of Public Procurement (Preference to Make in India), Order 2017 and we qualify as..... (Class-I/ CLASS-II/ Non-Local supplier - fill in one which is applicable) local supplier.

We further confirm that details of location at which the local value addition is made will be at (address of the works).

The above declaration does not include services such as transportation, insurance, installation, commissioning, training and after sales service support like AME/CMC etc. as local value addition.

We also understand, false declarations will be in breach of the Code of Integrity under Rule 175(1) (i) (h) of the General Finance Rules for which a bidder or its successors can be debarred for up to two years as per Rule 151 (iii) of the General Finance Rules along with such other actions as may be permissible under law.

I hereby declare that the details furnished above are true and correct to the best of my knowledge and belief, and I undertake to inform you of any changes therein, immediately. In case any of the above information is found to be false or untrue or misleading or misrepresenting, I am aware that I may be held liable for it.

Yours very truly,

..... (authorized signatory of company with seal)

..... (firm name)

Authorized signatory
of company

DECLARATION BY VENDOR

We declare that the following family firms or sister concern affiliates / subsidiary firms are participating in the tender No E.....:

1.0

2.0

3.0

.....

I, hereby declare on behalf of M/s and the family firms or sister concern affiliates / subsidiary firms listed above that we are not indulging in cartel formation for Enquiry No E.....

(.....)

For M/s

(Seal & Sign)





BP 200102A

GENERAL TERMS AND CONDITIONS OF ENQUIRY

Sl.No.	Description
1	General:
A	These General terms & conditions (GTC) shall apply to all enquiries, notice inviting tenders, request for quotations concerning the supply of goods and / or rendering of services to Bharat Heavy Electricals Ltd., Bhopal (hereinafter referred to as BHEL or the Purchaser) or its Projects / Customers. Special / supplementary enquiry conditions, if any, will override the conditions in this annexure.
2	General Instructions - Common for Indigenous & Foreign enquiries
A	Through E- procurement
A1	<ol style="list-style-type: none">Offer shall be submitted by the bidders in single/two parts as called in Tender enquiry. Bid Part - I Technical cum Commercial bid Bid Part - II Price bidSuppliers shall quote price on BHEL authorised third party service provider e-procurement site. Any deviation from the price format shall be clearly brought out in the offer Bid Part I. <p>The offer shall be uploaded on BHEL e-procurement site using Class III digital signature. All documents to be uploaded are necessarily to be signed and stamped. The quotation should be uploaded on the site before due date and time. Part-I of the bid shall contain complete item-wise scope of supply as offered vis-à-vis the scope of supply as per enquiry, all commercial terms and conditions etc. It is expected that bidders shall meet all our technical and commercial requirements and shall not deviate from them.</p>
B	Through tender room
B1	Sealed bids are invited for scope of Supply / Services as detailed in the enquiry. Bid should be free from correction, overwriting, using of corrective fluid etc. Any interlineation, cutting, overwriting shall be valid only if they are attested under full signature(s) of persons signing the bid else shall be liable for rejection. All overwriting/ cutting etc. will be numbered by bid opening officials and announced during bid opening. The bid should be submitted in English or Hindi language. Relevant enclosures, supporting documents, catalogue, samples, if any, as required as per Notice Inviting Tender (NIT) conditions shall be sent along with technical offer. Rate should be quoted in the units asked for in the enquiry.
B2	Bids shall be submitted in a Sealed cover with Enquiry No., Due date and Bidder's name indicated on the cover. In case of Two Part Bid, technical bid containing technical offer, this GTC duly filled-in & signed; and un-priced copy of the Price Bid should be kept in one envelope. Price Bid containing only the price (as called for in the price format where required) should be kept in a separate envelope. Both envelopes indicating Part —I or Part-II as the case may be to be put in a bigger envelope, which should be addressed to in charge, Tender Room, Bharat Heavy Electricals Ltd. 2 nd Floor, Jawahar Bhavan, Piplani, Bhopal 462022. Enquiry No., due date and bidder's name must be mentioned on all envelopes. Offer must reach tender room of BHEL Bhopal latest by 11.00 am IST on the enquiry due date. Bids submitted as single part bid against two – part bid, shall be rejected unless the offer is techno-commercially acceptable without seeking any clarification.
B3	Offer received after 11.00 AM IST of the due date will be termed as "Late" and shall not be considered. However, late offer received against single tender enquiry may be considered.
B4	Bidder can also submit offer through email, if called for in the enquiry, at the email address indicated in the enquiry. Such email offers shall be sent only on designated email-id to reach before 11.00 am IST on the tender due date. BHEL will not be responsible for incomplete offers and the ones delivered late through e-mail.
C	Through tender room or EProcurement
C1	Commercial Conditions quoted by the bidder in any place including as stated in bidder's 'General Terms and Conditions' if any, shall not be binding on the Purchaser and the conditions contained in this annexure, including special conditions, if any, for this enquiry shall only prevail.
C2	Rate should be quoted in the units asked for in the enquiry. The rates should be quoted both in figures and words. In case of discrepancy in figures and words, the rates quoted in words shall be considered.
C3	The goods offered shall conform to BHEL specifications and / or National/International standards as mentioned in the Enquiry and the bidder is required to confirm his unconditional acceptance to the same. Bidders, seeking deviations from the specifications and any other conditions, may indicate the same clearly on a separate sheet indicating Sl. No. of the item, with reasons for such deviations. BHEL reserves the right to reject the offer with deviations or load the deviations suitably for evaluation.
C4	Offers shall be submitted directly by bidder or his authorized agent only. Unsolicited offers shall be summarily rejected.



BP 200102A

GENERAL TERMS AND CONDITIONS OF ENQUIRY

C5	Bid in single part or techno-commercial bid in two-part system (as the case may be) will be opened on the due date. In case of two part bid, price bids of techno-commercially accepted bidder(s) only shall be opened on the assigned date, for which separate intimation will be sent to the accepted bidders.
C6	The bidder whose bid is technically not accepted will be informed & EMD wherever submitted shall be returned along with his price bid within <i>30 days</i> of contract finalization date. No interest will be payable on EMD amount. EMD shall however be forfeited in the event of bidder opting out after submission of the bid.
C7	<ol style="list-style-type: none">1.Any discount / revised offer submitted by a bidder on its own shall be considered, provided it is received on or before the due date and time of offer submission (Part-I). Conditional discounts shall not be considered for evaluation of tenders.2.Unsolicited discounts / revised offers given after Part-I bid opening shall not be accepted. No change in price will be permitted within the validity period of offer.3.In case of changes in scope and / or technical specification and / or commercial terms & conditions, having price implication, techno-commercially acceptable bidders shall be asked by BHEL to submit the impact of such changes on their price bids. In case a bidder opts to submit revised price bid instead of impact called for, then latest price bid shall prevail. However in both situations, original price bid will be necessarily opened.
C8	The bidders will submit Integrity Pact, duly signed by its authorized signatory, where called for in the enquiry.
C9	Wherever the enquiry is issued to unregistered bidder, the bidder shall visit ' www.bhel.com ' for submitting the online Supplier Registration Application. Price bids of such bidders, will be opened only on techno-commercial acceptance of bid & after supplier registration.
C10	BHEL expects that the bidder responds to the enquiry. Regret letter, with valid reasons for not participating in the tender will be submitted where the bidder is unable to submit offer. Repeated lack of response on the part of bidder may lead to his deletion from BHEL's approved bidder list. Refer guidelines for suspension of Business Dealings with Suppliers/Contractors available on https://www.bhel.com/sites/default/files/suspension_guidelines_abridged.pdf
C11	In case of open tenders (i.e. those published in website) all corrigenda, addenda, amendments, time extensions, clarifications etc. to the tender will be hosted on BHEL website. (www.bhel.com) only. Bidders responding to these tender should regularly visit website(s) to keep themselves updated.
C12	In the course of evaluation, if more than one bidder happens to occupy L-1 status effective L-1 will be decided by soliciting discounts from the respective L-1 bidders in sealed envelope and will be open in tender room. In case more than one bidder happens to occupy the L-1 status even after soliciting discounts, the L-1 bidder shall be decided by a toss/ draw of lots, in presence of the respective L-1 bidders or their representatives. Ranking will be done accordingly. BHEL's decision in such situations shall be final and binding.
C13	The Purchaser can consider awarding tendered quantities among more than one bidder (after acceptance of L1 price by the other bidders) in the manner and proportion disclosed in the tender conditions. Purchaser can also consider awarding of part of the tendered quantity to other than L-1 bidder at L1 counter offered rates, if the quantity offered by the L-1 bidder is less than the quantity tendered for.
C14	The bidder shall submit price bid strictly in the price format, wherever provided for, in the enquiry. Any attempt on the part of the bidder to alter the contents of the price bid format in any manner, which in the opinion of BHEL can vitiate the tendering process, will lead to rejection of the bid, <i>besides BHEL taking appropriate punitive action as deemed fit.</i> Refer Guidelines for suspension of Business Dealings with Suppliers/Contractors available on https://www.bhel.com/sites/default/files/suspension_guidelines_abridged.pdf
D	BHEL shall be resorting to Reverse Auction (RA) (Guidelines as available on www.bhel.com). If tender specific conditions call for reverse auction, RA shall be conducted among the techno-commercially qualified bidders. Price bids of all techno-commercially qualified bidders shall be opened and same shall be considered for RA. In case any bidder(s) do(es) not participate in online Reverse Auction, their sealed envelope price bid along with applicable loading, if any, shall be considered for ranking
3	Delivery Terms
A	Indigenous Purchase
A1	Goods shall be delivered on 'FOR Destination' basis to the named destination unless otherwise called for in the enquiry.
B	Foreign Purchase — Imports
B1	<ol style="list-style-type: none">1. Goods shall be despatched by Sea, unless stated otherwise in the enquiry or purchase order.2. Terms of Delivery for Sea shipment shall be on CFR / CIF basis with 14 days' detention free period preferably at Dry Port - ICD Mandideep (INMDD6) for FCL (Full Container Load) Cargo of GP & HC Containers.3. For other cases - Other than GP & HC Containers, LCL Cargo shall be delivered at Nhava Sheva (JNPT- INNSA1) & Break-bulk Cargo at Mumbai (MPT - INBOM1).4. For Air consignments, the terms of delivery shall be FCA at BHEL nominated Airport. In case of CIP, delivery shall be at Mumbai ACC (INBOM4).5. Freight amount shall be indicated separately in the offer in case of CIP/CFR/CIF.



BP 200102A

GENERAL TERMS AND CONDITIONS OF ENQUIRY

	<p>6. The number of detention free days and destination charges payable to shipping line must be mentioned in your offer and also on the Bill of Lading.</p> <p>7. Offer received on FOB basis may be considered on an exceptional basis. BHEL will load freight, marine insurance & shipping line port handling charges etc. to work out landed cost at Sea Port.</p> <p>8. Please visit BHEL Bhopal website https://bpl.bhel.com for details of named Air ports and Sea ports. Name of the gateway port so chosen by the bidder shall be indicated by the Bidder in his offer.</p> <p>9a In case of CIP/CFR/CIF, the shipping line should be ready to move the containers to consignee's nominated CFS (Container Freight Station) yard and Indian agent of shipping line should issue Cargo Arrival Notice (CAN) 7 days in advance.</p> <p>9b In case of CFR contract, bidder to supply the material through a Certified Sea worthy vessel age not more than 15 years.</p> <p>9c The invoices being issued by shipping lines must be in the name of BHEL. Otherwise, BHEL will recover loss of Input Credit on GST from the vendor.</p> <p>9d While booking the shipment, bidder to also finalize destination charges and the same should appear over BL or agreed tariff to be provided to BHEL before arrival of shipment. If cargo is stuffed in container, then the same should be allowed to be moved to CFS of importer's choice without any additional charges.</p> <p>9e Load port charges shall be settled by the supplier and not be passed on to BHEL in any form of destination charges.</p> <p>10. For reasons of delay in receipt of documents from suppliers or due to the same being found to be incomplete, and or faulty, the suppliers shall be responsible to reimburse all penalties, detention and demurrages / wharfages, if any paid by BHEL (for stated reasons).</p>	
B2	<p>1. For delivery of FCL (Full Container Load) cargo, the Bidder shall provide minimum 14 days' detention free period from the date of delivery at Port of Discharge / Place of Delivery (in case of ICD). Wherever the detention free period offered is less than 14 days, the bids shall be loaded for the period short of 14 days' period.</p> <p>2. <u>Port Congestion charges or any additional charges claimed by the shipping line at Port of Discharge / Place of Delivery shall be to the Bidder's account.</u></p>	
4	Bidder's particulars & logistics information (Bidder to give details against each of the provisions)	
A	Name of the bidder's executive to deal with this tender / project	
B	E-mail address of the contact person	
C	Telephone no. of the contact person	
D	Name of location from where the goods shall be offered for inspection and dispatch	
5	Additional logistics information for Imports	
A	Bid currency	
B	Charges applicable at discharge port up to BHEL's CFS (Container Freight Station) to be indicated in your offer and on the B/L	
C	Name of Airport in the country of dispatch for FCA delivery terms	
D	Estimated number, type & size of containers for delivery of tendered quantity (applicable where the goods are to be sent in FCL)	
E	No. of packages with cumulative gross weight and CBM volume (applicable for LCL & Break-bulk shipment)	
F	Approx. distance in km. from Bidder's works to Port of Loading	Sea port /Air port
6	Delivery Schedule & Completion date	
A	<ul style="list-style-type: none"> • Instead of writing specific date against delivery offered, bidder shall commit delivery period in number of days / weeks/ months to suit the delivery period indicated in the enquiry. • Commencement of delivery period shall be reckoned from the date of PO / LOI or any other agreed milestone. • Bidder shall deliver the goods in the manner and schedule agreed under the Purchase order. • Goods shall be delivered within contractual period or any extension thereof, if any, granted by the Purchaser. • If delivery is linked to approval of documents, time for submission of such documents to be indicated and delivery period to be indicated from approval of documents. This delivery schedule will be considered for processing delivery extension, wherever applicable. • BHEL reserves the right to cancel the order if material is not delivered within PO scheduled delivery. 	



BP 200102A

GENERAL TERMS AND CONDITIONS OF ENQUIRY

B	In case of foreign supplies, the date of Bill of Lading (B/L) or AWB shall be taken as actual date of delivery where freight until discharge port in India is in Seller's scope like CFR/CIF/CIP delivery terms. For Ex-works/FCA/FOB or any other delivery term where freight is in buyer's scope, date of material readiness /Test certificate/ Warehouse receipt/Freight forwarder receipt may be considered as mutually agreed.
C	In case of Indigenous bidders, the date of delivery at named destination in India shall be taken as contractual delivery completion date where delivery terms are FOR destination. In case of 'Ex-works' delivery terms, the date of LR / RR shall be the contractual delivery completion date.
7	Transit Insurance
A	Except where delivery terms are agreed on CIF basis for Imports & FOR destination basis for indigenous purchases, transit insurance will be covered by BHEL under its Open Marine Transit Insurance Policy. Bidder shall inform dispatch particulars with value of consignment to the Purchaser within 07 days of dispatch for BHEL to arrange insurance coverage in its policy. Failure on the part of bidder to inform dispatch particulars will make him liable to pay for any transit damages / losses suffered by the Purchaser.
8	Force Majeure
A	Notwithstanding anything contained in the contract, neither the Bidder nor the Purchaser shall be held responsible for total or partial non-execution of any of the contractual obligations, should the obligation become unreasonably onerous or impossible due to occurrence of a 'Force Majeure' which directly affects the obligations to be performed by the Purchaser or the Bidder; Such events include war, military operations of any nature, blockages, revolutions, insurrections, riots, civil commotions, insurgency, sabotage, acts of public enemy, fires, explosion, epidemics, quarantine restrictions, floods, earthquake, or acts of God, restrictions by Govt. authorities; over which the Bidder or the Purchaser has no control. The party claiming to be affected by force majeure shall notify the other party in writing without delay, within two weeks on the intervention and on the cessation of such circumstance. Extension of time sought by the Bidder along with supporting evidence and so granted by the Purchaser for the supply/ work affected, if any, shall not be construed as waiver in respect of remaining deliveries. Rescheduling of deliveries on account of force majeure conditions, if so agreed by the Purchaser, will not entail the Bidder to claim any increase in the price on whatsoever account. Notwithstanding above provisions, Purchaser shall reserve the right to cancel the order/ Contract, wholly or partly, in order to meet the overall project schedule and make alternative arrangements. If deemed necessary, Purchaser may takeover partly processed material at a mutually agreed price.
9	Penalty for delayed performance.
A1	Subject to force majeure conditions, penalty shall be 0.5% of the total order value per week of delay or part thereof, subject a maximum of 10% of the total order value. Total order value above shall be item wise, lot wise order value. Any deviation based on specific requirement shall be specified separately in the NIT.
A2	However, in case of Capital Machine / BOP where staggered deliveries may be applicable, the penalty will be levied on total order value.
A3	In case of any amendment / revision, the penalty shall be linked to the amended / revised PO.
A4	Any loading on penalty clause shall be to the extent to which it is not agreed to by the bidder (at offered value)
B	If the material is not supplied within the agreed delivery period, BHEL reserves the right to cancel the order and purchase the material from alternate source(s) at the Risk and Cost of the Bidder. In such an event, it shall be obligatory on the part of bidder to make good any loss suffered by the purchaser.
C	In case the contractually agreed delivery date falls on a holiday in BHEL Bhopal, the next working day shall be taken as contractual delivery date for compliance and applicability of LD / penalty.
D	In case of any recovery for delayed performance, the applicable GST shall also be recoverable from bidders.
10	Indian Agents and Agency commission
A	BHEL prefers to deal directly with Foreign bidder, wherever required, for procurement of Goods. However if the Foreign Principal desires to avail services of an Indian Agent, then the Principal should ensure compliance to "regulatory guidelines" which will require submission of an agency agreement.
B	The CFR / CIF price quoted will be deemed to be inclusive of Indian Agency commission. Agency commission as disclosed by the bidder in his quoted CFR / CIF price will be paid in Indian Rupees on receipt & acceptance of Materials or it's installation at destination, as the case may be. The lower of the 'TT buying rate prevailing on the date of technical bid opening or price bid opening shall be considered for computation of Agency commission.
C	In a tender either the Indian Agent on behalf of Principal / OEM or the Principal / OEM itself can bid, but both cannot bid simultaneously for same item / product in the same Tender. In case bids are received from both the Principal / OEM and the agent, bid received from the agent will be ignored.
D	If an agent submits Bid on behalf of the Principal / OEM, the same agent shall not submit bid on behalf of another Principal / OEM in the Tender, for the same Item / Product.



BP 200102A

GENERAL TERMS AND CONDITIONS OF ENQUIRY

11	Documentation:		
A	Indigenous Purchase		
	<p>Bidder shall arrange to send to the consignee, Original Tax invoice (Buyer's copy and duplicate for Transporter), Commercial invoice in duplicate, consignee copy of LR & 2 sets each of Packing list, Test certificate, Guarantee / Warranty certificate, O & M manuals (where applicable), immediately on despatch of the goods. The distribution of such documents will be specified in the Purchase order.</p> <p>In case of labour / mixed basis jobs, material is issued free of cost. Necessary material reconciliation is to be done and Free Issue Material Statement (FIMS) is to be submitted with each bill.</p>		
B	Foreign Purchase — Imports		
	<p>Seller shall send 1 set of following documents, in English, within 7 days of B/L date / 1 day of AWB date by courier to the Purchaser</p> <ol style="list-style-type: none"> Express / Original 'Clean on board' Bill of Lading / AWB. One set of Commercial Invoice, Packing list indicating container-wise Gross weight, Net weight, CBM volume, No. of packages with Dimensions of each package. Original Certificate of Country of Origin (COO) issued by Chamber of Commerce. COO shall be as per requisite format where duty concession is available under Preferential Trade/Comprehensive Economic Partnership/Free Trade agreement. Customs tariff heading (CTH)/ Harmonized System of Nomenclature (HSN) code of material should be mentioned on invoice and COO in all such cases. One set of Original Test Certificates and O&M Manual where called for. Fumigation / Phyto-Sanitary Certificate wherever cargo is packed in wooden packing or packing of plant origin material is used. Supplier should additionally forward 2 sets of original documents mentioned at point nos. 1 to 5 above along with Original Bill of Lading (OBL) or AWB through any international courier service/registered airmail within three (3) days of obtaining the same directly to the following: <table border="1" data-bbox="322 1037 1520 1265"> <tr> <td> AGM (M.S) Regional Operations Division BHEL 14th Floor Centre-1 World Trade Centre, Cuffe Parade Mumbai 400 005 INDIA Email: msseabpl@bhel.in (In case of Sea freight) msair@bhel.in (In case of Air freight) </td> <td> DGM (FIN- FP) 4th Floor, Administrative Bldg. BHEL Bhopal - 462022 (India) E-mail : fin_fp.bpl@bhel.in </td> </tr> </table> <p>And confirm forwarding details to AGM (CMM- FE), BHEL Bhopal at mmfe.bpl@bhel.in</p> <ol style="list-style-type: none"> In case the Seller decides to negotiate all 3 originals of B/L / AWB along with all original documents through negotiating Bank, non-negotiable documents (NNDs) consisting of copy of B/L / AWB & documents mentioned at Sl. no. 11- B2 to B5 will be sent by e-mail to the Purchaser at his e-mail address given in the PO with one copy to be mailed at mmfe.bpl@bhel.in as well as at msseabpl@bhel.in (for Sea shipment) or msair@bhel.in (for Air shipment). Other documents, as required, will be separately indicated in the Purchase Order. Additional expenditure, if any, incurred by the Purchaser by way of detention / demurrage, resulting out of delay attributable to the Seller in providing Negotiable documents, will be recovered from the Seller. <p>In case any discrepancy is raised by the Bankers / BHEL with respect to the documents submitted, vendor to facilitate clearance of goods through Delivery Order.</p> <p>Additionally, following requirements to be taken care of by the bidder during PO execution stage:</p> <ol style="list-style-type: none"> IEC (0588138690), GSTIN (23AAACB41461ZN) and email ID (mmfe.bpl@bhel.in) of BHEL Bhopal shall be clearly mentioned on B/L or AWB. As per Uniform Customs Practice (UCP 600) for documentary credits (L/C), presentation period allowed is maximum 21 days after the date of shipment. However, for geographically closer ports where sea voyage time is less than 3-4 weeks, a shorter presentation period shall be agreed upon. In case of CAD payment terms, Supplier shall send documents to BHEL's bank within 5 days of shipment. One set of original may be sent to any one of ROD, CMM-FE and MM, copy may be marked to the others. For Air shipments through non-CONSOL (i.e., not through BHEL ROD's contract), Delivery Order (DO) should be given to BHEL without insisting for Bank Release Order (BRO). AWB to be drawn with BHEL Bhopal as consignee. It must be ensured that original shipping/commercial documents, if not provided to BHEL outside banking channel, should reach BHEL's bank at least 10 days prior to cargo arrival at port. Part shipment and trans-shipment to be avoided to the extent possible especially where it is not possible to split shipping & commercial documents. Part shipment shall be strictly avoided for Airshipments. 	AGM (M.S) Regional Operations Division BHEL 14 th Floor Centre-1 World Trade Centre, Cuffe Parade Mumbai 400 005 INDIA Email: msseabpl@bhel.in (In case of Sea freight) msair@bhel.in (In case of Air freight)	DGM (FIN- FP) 4 th Floor, Administrative Bldg. BHEL Bhopal - 462022 (India) E-mail : fin_fp.bpl@bhel.in
AGM (M.S) Regional Operations Division BHEL 14 th Floor Centre-1 World Trade Centre, Cuffe Parade Mumbai 400 005 INDIA Email: msseabpl@bhel.in (In case of Sea freight) msair@bhel.in (In case of Air freight)	DGM (FIN- FP) 4 th Floor, Administrative Bldg. BHEL Bhopal - 462022 (India) E-mail : fin_fp.bpl@bhel.in		
C	General		
	<ol style="list-style-type: none"> For Hazardous chemicals, the materials safety data sheet (MSDS) is to be submitted. 		



BP 200102A

GENERAL TERMS AND CONDITIONS OF ENQUIRY

	<p>2. All certificates as called must be sent. BHEL may test any goods supplied and their decision is final irrespective of supplier's certificates. If test certificate and guarantee certificate are not received along with the document and stipulated in these specifications, BHEL reserves the right to get the material tested and recover the expenses from the supplier without awaiting supplier's confirmation</p> <p>3. Goods shall be properly packed to avoid transit damage. Suitable markings shall be provided to identify the goods with that of the PO No. and the consignee details.</p> <p>4. Goods shall be consigned to AGM (CRX), BHEL, Piplani, Bhopal - 462022, India, unless otherwise specified in the PO.</p>
12	Pricing Terms
A	Prices once quoted shall remain firm within the validity or any extension thereof for placement of order, till complete execution of the order, without any escalation/increase for any reason, whatsoever, unless specifically provided for in the Enquiry & PO. In case of foreign bidders, the quoted price shall be taken as inclusive of Third Party Inspection and testing charges as called for in the NIT.
13	Price Validity :
A	Unless stated otherwise in the enquiry, offer shall be valid for a period of 90 days from the date of Techno- commercial (Part-I) bid opening date.
14	Taxes & Duties - Indigenous Purchase
A	Bidder to ensure timely remittance of SGST, CGST , IGST as applicable in time as per law.
B	Bidder to ensure compliance to filing of monthly GST sales return including BHELs supplies by 10 th of next calendar month in the online GST portal wherever applicable.
C	Bidders to declare filing of timely returns and GST remittance/likely remittance /ITC adjustment along with invoice.
D	Bidder to submit invoices compliant with GST invoice Rules
E	Bidders to comply with all statutory provisions as may be applicable at the time of despatch/sale. Any additional financial liability to BHEL on account of non-compliance by bidders shall be borne by them and shall be adjusted / recovered from the bidders. BHEL reserves the right to review the existing offers / contracts for any revision in terms, which may arise due to change in any statutory provisions to ensure that the benefit accrues to BHEL.
F	Bidder to ensure TAX INVOICE submission along with consignment
G	In respect of cases where the liability to discharge GST is on BHEL under reverse charge mechanism, bidders have to ensure timely submission of invoices and delivery of material / services to BHEL, so that there is no mismatch on both activities. In case there is any additional financial liability on BHEL on account of default on the part of the bidder on submission or delivery of material / services the same shall be passed on to them.
H	In respect of free issue material by BHEL, bidders have to return the processed material within the time line as per the provisions of GST. In case of any additional tax liability on BHEL on account of non-compliance by the bidder, the additional financial implications on BHEL shall be passed on to the bidder
I	Bidders to provide the applicable HSN / SAC codes as called for in the enquiry
J	As per provisions of section 171 of the CGST Act 2017, bidders to pass on the anti-profiteering benefits accruing to them under GST regime to BHEL
K	With reference to section 51 of CGST act 2017 read with notification no 50/2018 – Central tax dated 13.09.2018; BHEL will be liable to deduct TDS under GST with effect from 01.10.2018. Deduction shall be made @ 2% (1% CGST + 1% SGST) or 2% IGST (as applicable) of the payment made or the amount credited. Bidder to generate & submit invoices as per above. The amount of TDS shall be deposited to the Government account and BHEL shall issue TDS certificate to deductees, TDS deposited in the Government account will be reflected in the electronic cash ledger of the deductee who will be able to use the same for payment of tax or any other amount. Deduction of TCS along with additional TDS will be as per prevailing Government guidelines.
15.	Taxes & Duties - Foreign Purchase — Imports
A	The offered prices shall be inclusive of all the Taxes and duties as applicable in the country of bidder / country of dispatch for the quoted CFR / CIF price.
16	Payment Terms-
A	Indigenous: 100% payment in 90 days of receipt (45 days for MSE including Udyog Aadhar/ Udhyan registered suppliers as per relevant act in force), subject to acceptance of material and relevant documents at BHEL. In case of despatch of material to site directly, site certification for receipt of materials is required unless otherwise provided for in the PO. Any deviation from the above payment terms, if accepted (by BHEL), shall be loaded @ SBI base rate + 6% for the purpose of bid evaluation.
B	Foreign: 100% against irrevocable, unconfirmed LC, payable within 90 days of the Bill of Lading (B/L) date or Payment terms of CAD payable on 90 th day of B/L / AWB. In case BHEL considers any deviation in payment terms i.e. early payment based on bidder's request, then bids shall be evaluated with loading of State bank of India Base rate plus 6%, for the credit



BP 200102A

GENERAL TERMS AND CONDITIONS OF ENQUIRY

	<p>period short of 90 days. The LC shall be established 2 months prior to shipment date, valid for period of 90 days, unless agreed otherwise.</p> <p>Documents to be submitted as per UCP600 and should reach BHEL/ BHEL's bank at least 7 days prior to vessel arrival.</p>
C	<p>Foreign bidders to submit declaration of Permanent Establishment and Business Connection (PEBC) for remittances purpose. Declaration to be submitted in formats either in Annexure A or B whichever is applicable as per their transaction entered into with BHEL.</p> <p>In the absence of certificates from the bidder, withholding tax at applicable rates along with surcharge and cess will be recovered at the time of remittance to the bidder.</p>
D	<p>Foreign bidders to submit Tax Residency Certificate (TRC) & Form 10F (for obtaining DTAA benefits) as per Annexure C in respect of services. The TRC (tax residency certificate) is to be issued by the authorities of the government of bidder's country. If the informative part of the format (other than residency) is not furnished by the authorities the same may be furnished by the bidder as a declaration.</p>
17	Inspection of Goods
A	<p>The Bidder shall give adequate notice, of 1 week or as mutually agreed period, in writing to the Purchaser (in case Customer inspection is involved) or BHEL appointed TPIA about the date and place at which the goods will be ready for inspection/ testing, as provided for in the contract.</p>
B	<p>Purchaser or his authorized representative shall be entitled to carry out inspection of material and workmanship/Surveillance Audit at Bidder's premises or at his sub-contractor's premises at all reasonable times during execution of contract; Such inspection, examination and testing, if made, shall not absolve the Bidder from his obligations under the contract.</p> <p>Wherever required, BHEL may carry out testing at BHEL's testing Lab and in case of any rejection during such testing, replacement / rectification, as required, will have to be done by Supplier.</p> <p>If BHEL carries out any rectification of such rejected material, such cost will be recovered from Supplier's Bills.</p> <p>In case of Customer inspection as Supplier's Works, inspection clearance to be obtained from Customer and submitted to BHEL.</p>
C	<p>BHEL's representative from unit or Corporate Quality (CQ) is authorised to carry out audits along with TPIA at bidder's works before clearing the items for despatch.</p>
D	<p>All costs related to inspections and re-inspections shall be borne by the Bidder. In case of inspection by BHEL and / or BHEL's customer, the cost of to & fro passage and Boarding & Lodging shall be borne by the Purchaser / Customer, unless otherwise specifically agreed. In case of foreign bidders, the cost of third party inspection, where called for, shall be deemed to be included in the quoted price. Bidder shall be responsible to provide assistance such as labour, materials, electricity, fuels, stores, apparatus, instruments at his cost, as may be required and as may be reasonably demanded to carry out such tests effectively.</p>
E	<p>REJECTION:</p> <p>If any goods are rejected, BHEL shall be at liberty to take action as per following at the risk and cost of supplier:</p> <p>a) Allow the supplier, wherever mutually agreed, to rectify the rejected goods at BHEL's works within reasonable time as fixed by BHEL.</p> <p style="text-align: center;">Or</p> <p>b) Allow the supplier to make free replacement within a specified period. Rejected goods can be lifted by the supplier thereafter.</p> <p style="text-align: center;">Or</p> <p>c) In case payment has been done, allow supplier to refund equivalent value of rejected material by NEFT / RTGS or furnish Bank Guarantee for same amount before lifting the rejected goods. Fresh replacement shall be regulated as per terms and condition of the original Purchase Order.</p> <p>In case payment has not been done, allow the supplier, wherever mutually agreed, to rectify the rejected goods at supplier's works within reasonable time as fixed by BHEL.</p> <p style="text-align: center;">Or</p> <p>d) Take alternate procurement action from elsewhere and recover the difference in total cost to BHEL including services, if any, incurred by BHEL in this regard from the supplier. The supplier shall not be entitled to any gain on repurchase.</p> <p style="text-align: center;">Or</p> <p>e) Terminate the contract either in part or in whole at the discretion of BHEL and recover the loss, if any, from the supplier.</p> <p style="text-align: center;">Or</p>



BP 200102A

GENERAL TERMS AND CONDITIONS OF ENQUIRY

	f) Any goods rejected by BHEL must be removed by the supplier after making payment through NEFT / RTGS within 30 days after receipt of the intimation of rejection. If bidder fails to lift or allow despatch of rejected material at his cost within 90 days from the intimation of rejection, his claim on rejected material shall cease.
18	Guarantee / Warranty and corresponding Repairs / Replacement of Goods
A	Manufacturer's works test/inspection certificates shall be furnished along with the guarantee that material conforms strictly to the specification for general & special conditions as laid down in the purchase order. Goods shall comply with the specifications for material, workmanship and performance. The warranty shall be for a period of 12 months from the date of receipt. If the delivery is found non-compliant during the warranty period, leading to rejection, the Bidder shall arrange free replacement / repair of goods, within one month from the date of intimation or any mutually agreed period. The rejected goods shall be taken away by the Bidder at his cost and replaced on Delivered Duty Paid (DDP) (FOR - BHEL Stores/ designated destination basis) within such period. In the event of the Bidder's failure to comply, Purchaser may take action as appropriate, including Repair / Replenish rejected goods & disposal of rejections, at the risk & cost of the Bidder. In case the defects attributable to Bidder are detected during processing of the goods at purchaser's / his subcontractor's works, the Bidder shall be responsible for free replacement/ repair of the goods as required by the purchaser.
19	Evaluation and Loading Criteria:
A	The evaluation currency for this tender shall be INR. Evaluation of the tender shall be on the basis of delivered cost, i.e. 'total cost to BHEL' w.r.t the technical scope and commercial conditions finalized after techno-commercial clarifications (after considering, inter alia, Customs Duty and GST / Other taxes as applicable). Exchange rate (TT selling rate of State Bank of India) applicable on the date of Part-I bid opening shall be considered for evaluation of foreign bids. If the relevant day happens to be a bank holiday in India, then the FOREX rate as on the previous bank working day shall be taken for evaluation. Foreign suppliers shall ensure that the benefits as applicable under Comprehensive Economic Partnership Agreement (CEPA) with Government of India are disclosed in the bid & relevant documents such as Certificate of Country of Origin, issued by the appropriate authority in the country of Export, is provided by the bidder along with dispatch documents. Bids shall be evaluated with such applicable benefits. In the event of Bidder failing to provide appropriate documents for Purchaser to avail disclosed concessional duty benefits in India, financial loss, so incurred, will be to the Bidder's account.
20	Variation of orders
A	No variation to the Purchase order is permitted unless authorised in writing and signed by or on behalf of purchase executive, BHEL Bhopal.
21	Sub-contract
A	BHEL's order or part there off, if further to be subcontracted in exceptional circumstances the details of subcontracting and to whom to be subcontracted shall be furnished to BHEL and written permission shall be obtained from BHEL. However, it shall not absolve the supplier of the responsibility of fulfilling BHEL order requirements.
22	Recovery / deductions of amount from supplier
A	a Any amount on account of recovery from consignor / supplier under any condition shall be liable to be adjusted against any amount payable to the consignor/supplier against bills. b For any deficiency in supplies where deduction is involved, an amount as decided by BHEL, shall be deducted from supplier's bills.
23	Safety clause for purchase orders
A	The bidders shall maintain and ensure sufficient safety measures as required for inspections and test like HV test. Pneumatic test, Hydraulic test Spring test, Bend test, Material handling and safe working environment etc. to enable Inspection Agency for performing inspection. The bidder shall ensure that all the safety precautions specified in factories Act 1948 chapter-IV Section-21 to 41 are complied with respect to equipment's to be inspected. If any test equipment is found not complying with proper safety requirement, then the inspection agency may withhold inspection, till such time the desired safety requirements are met.
24	Non-Disclosure Agreement
A	All Drawing and technical documents relating to the product or it's manufacture submitted by one party to the other, prior or subsequent to the formation of contract, shall remain property of the submitting party. Drawing, technical documents or other technical information received by one party, shall not without the consent of the other party, be used for any other purpose than that, for which they were provided. Such technical information shall not without the consent of the submitting party, otherwise be used or copied, reproduced, transmitted or communicated to a third party. Patterns supplied by BHEL will remain BHEL's property which shall be returned by the bidder on demand to BHEL. Bidder shall in no way share or use such intellectual property of BHEL to promote his own business with others. <i>BHEL reserves the right to claim damages from the bidder, or take appropriate penal action as deemed fit against the bidder, for any infringement of the provisions contained herein.</i>



BP 200102A

GENERAL TERMS AND CONDITIONS OF ENQUIRY

	DRAWINGS, PATTERNS & TOOLS: All drawings, patterns & tools supplied by BHEL or made at BHEL's expense are BHEL's property. These cannot be used or referred to any other party and must only be used in the execution of BHEL's orders. These should be preserved at the supplier's cost for a period of not less than 5 years. Patterns & tools should be returned to BHEL within 90 days of issue of the same.
25	Settlement of Disputes & Arbitration
A	All questions/interpretations regarding subject matter of the Contract shall be decided by the Purchaser on the request of the Bidder and the decision of the Purchaser shall be final.
B	In case of dispute, steps shall be taken by the parties to the contract to settle the same through negotiations.
C	In case, dispute is not settled in negotiations, it shall be referred to Conciliator appointed by the competent authority of the Purchaser.
D	<p>Except as provided elsewhere in this Contract, in case amicable settlement is not reached between the Parties, in respect of any dispute or difference; arising out of the formation, breach, termination, validity or execution of the Contract; or, the respective rights and liabilities of the Parties; or in relation to interpretation of any provision of the Contract; or, in any manner touching upon the Contract, then, either Party may, by a notice in writing to the other party refer such dispute or difference to the sole arbitration of an arbitrator appointed by Head of the BHEL Unit/Region/Division issuing the Contract.</p> <p>The Arbitrator shall pass a reasoned award and the award of the Arbitrator shall be final and binding upon the Parties. Subject as aforesaid, the provisions of Arbitration and Conciliation Act 1996 (India) or Statutory modifications or re-enactments thereof and the rules made thereunder and for the time being in force shall apply to the arbitration proceedings under this clause. The seat of arbitration shall be Bhopal.</p> <p>The cost of arbitration shall be borne as per award of the Arbitrator.</p> <p>Subject to the arbitration in terms of Clause above, the Courts at Bhopal shall have exclusive jurisdiction over any matter arising out of or in connection with this Contract.</p> <p>Notwithstanding the existence or any dispute or differences and /or reference for the arbitration, the Contractor shall proceed with and continue without hindrance the performance of its obligations under this Contract with due diligence and expedition in a professional manner except where the Contract has been terminated by either Party in terms of this Contract. Administrative Mechanism for Resolution of CPSEs Dispute as stated in https://dpe.gov.in/guidelines/guidelines/chapters/2673.</p> <p>In the event of any dispute or difference relating to the interpretation and application of the provisions of the commercial Contract between Central Public Sector Enterprises (CPSEs)/Port Trusts inter-se and also between CPSEs and Government Departments/Organizations (excluding disputes concerning railways, Income Tax, Customs and Excise Departments), such dispute or difference shall be taken up by either party for resolution through Administrative Mechanism for Resolution of CPSEs Disputes (AMRCD) as mentioned in Department of Public Enterprises (DPE) Office Memorandum No. 4(1)/2013-DPE(GM)/FTS-1835 dated 22-05-2018 as amended from time to time."</p>
E	The Bidder shall continue to perform the contract, pending settlement of dispute(s).
26	Applicable Laws and Jurisdiction of Courts
A	Indian laws both substantive and procedural, for the time being in force, including modifications thereto, shall govern the Contract including Arbitration proceedings. The competent Courts at Bhopal in the State of Madhya Pradesh, India shall have sole jurisdiction.
27	RIGHT OF REJECTION /NON- PLACEMENT OF PO: BHEL reserves the right to accept the offers in part or in full, or cancel the Tender enquiry without assigning any reason.
28	Performance Bank Guarantee (PBG)/ Security Deposit (SD):
A	Wherever PBG (covering equipment / system / work performance guarantee) is called for in the Notice Inviting Tender (NIT) deviation shall not be accepted.
B	Bank Guarantee wherever called for, shall be in the BHEL prescribed format. In case the order is to be placed in foreign currency, the BG must also be in Foreign currency, so specified by the Purchaser.
C	Wherever Security Deposit (covering contract performance) is called for in the NIT, deviation shall not be accepted.
D	Composite 'Contract Performance Bank Guarantee' of matching value/ validity, where both Security Deposit and Performance Bank Guarantee are required, shall not be construed as deviation.
E	Wherever the contract is for supply of Goods processed on labour basis from BHEL supplied materials, the materials shall be issued against a suitable Bank guarantee as specified in the Enquiry.
F	Bidder agrees to submit performance security required for execution of the contract within the time period mentioned. In case of delay in submission of performance security, enhanced performance security which would include interest (SBI rate + 6%) for the delayed period, shall be submitted by the bidder. Further, if performance security is not submitted such security, the amount of performance security due shall be covered as per terms defined in NIT/ contract , from the bills along with due interest.
29	Benefits earmarked for Purchase from Micro & Small Enterprises (MSEs) –



BP 200102A

GENERAL TERMS AND CONDITIONS OF ENQUIRY

	<p>All benefits as per Government of India guidelines shall be given to eligible bidders.</p> <p>MSE bidders as defined by the MSMED Act as amended from time to time can avail the intended benefits only if they submit along with the offer, attested copies of relevant document stipulated in the MSMED Act or its rules/ regulations as amended from time to time and /or by the buyer. Non submission of such documents as stipulated hereinbefore will lead to consideration of their bids at par with other bidders. No benefit shall be applicable for the concerned for the tender enquiry, if any deficiency in the above required documents is not submitted before the price bid opening. If the tender is to be submitted through e-procurement portal, then the above required documents are to be uploaded on the portal. Documents should be notarized or attested by a Gazetted officer. This provision for MSE will apply subject to the condition that the participating MSE meets the tender requirements.</p> <p>In case of any change in the MSE status of the bidder, it shall be the responsibility of the bidder to notify the change as a part of the bid document. If at a later date it comes to the knowledge of BHEL, that the change in the status has not been intimated by the bidder and the order is obtained under the premise of an MSE then BHEL may reject the bid or, as the case may be, cancel the order and take necessary steps for suspension of the business dealing against the bidder as per the extant guidelines for suspension of business dealings with suppliers/ contractors of BHEL.</p> <p>Note: MSME benefits shall not be given to traders, Dealers or authorised agents.</p>
A	<p>MSEs shall be given tender documents free of cost and shall be exempted from payment of EMD. Tender documents shall be issued free of cost & no EMD wherever called for will be insisted upon. MSE bidders shall submit along with bid relevant documents w.r.t. their respective MSE status as per extant norms. Date to be reckoned for determining the deemed validity will be the last date of Technical bid submission. Non- submission of such document will lead to consideration of their bid, at par with other bidders and MSE status of such bidders shall be shifted to Non- MSE supplier till the supplier submit these documents.</p>
B	<p>In tender, participating MSEs quoting price within price band of L1+15% shall also be allowed to supply a portion of requirement by bringing down their price to L1 price in a situation where L1 price is from someone other than a MSE and such MSE shall be allowed to supply up to at least 25% of total tendered value. In case of more than one such MSE, the supply shall be shared proportionately.</p> <p>A quantum of 6.25% (25% out of target of 25%), so earmarked, will be reserved for MSE's owned by SC / ST entrepreneurs who submit their bid with relevant documents provided that in event of failure of such MSE(s) to participate in tender process or meet tender requirements and L1 price, 6.25% sub-target for procurement earmarked for MSE(s) owned by SC or ST entrepreneurs shall be met from other MSE(s).</p> <p>A quantum of minimum of 3% reservation within the above mentioned 25% reservation, so earmarked, will be reserved for MSE's owned by women entrepreneurs who submit their bid with relevant documents provided that in event of failure of such MSE(s) to participate in tender process or meet tender requirements and L1 price, 3% sub-target for procurement earmarked for MSE(s) owned by women entrepreneurs shall be met from other MSE(s).</p> <p>In case of indivisible tender, the full quantity shall be awarded to L1.</p>
C	<p>If an enterprise falling under MSE category as defined in the MSMED Act 2006, graduates to a higher category from its original category or beyond the purview of the Act, it shall continue to avail all non-tax benefits of its original category notified by the Ministry of Micro, Small and Medium Enterprise for a period of three years from the date of such graduation to the higher category.</p>
D	<p>MSE suppliers can avail the intended benefits only if they submit along with the offer, attested copies of either EM II certificate having deemed validity (five years from the date of issue of acknowledgement in EM II) or valid NSIC certificate or EM II certificate along with attested copy of a CA certificate (As per BHEL Format, where deemed validity of EM II certificate of five years has expired) applicable for the relevant financial year (latest audited). Date to be reckoned for determining the deemed validity will be the date of bid opening (Part 1 in case of two part bid). Non submission of such documents will lead to consideration of their bid at par with other bidders. No benefits shall be applicable for this enquiry if any deficiency in the above required documents are not submitted before price bid opening. If the tender is to be submitted through e-procurement portal, then the above required documents are to be uploaded on the portal. Documents should be notarized or attested by a Gazetted officer</p> <p>MSE bidders as defined by the MSMED Act as amended from time to time can avail the intended benefits only if they submit along with the offer, attested copies of either EM II certificate/ Udyog Aadhar Memorandum certificate having deemed validity (five years from the date of issue in acknowledgement in EM II/ Udyog Aadhar) or valid NSIC certificate or EM II/ Udyog Aadhar certificate along with attested copy of a CA certificate (Format enclosed as per Annexure I where deemed validity of EM II certificate/ Udyog Aadhar certificate of five years have expired) applicable for the relevant financial year (latest audited) or such other document as may be stipulated in the MSMED Act or its rules/ regulations as amended from time to time and /or by the buyer. The deemed validity will be assessed on the date of bid opening (Part 1 in case of two part bid). Non submission of such documents as stipulated hereinbefore will lead to consideration of their bids at par with other bidders. No benefit shall be applicable for the concerned for the tender enquiry, if any deficiency in the above required documents is not submitted before the price bid opening. If the tender is to be submitted through e-procurement portal, then the above required documents are to be uploaded on the portal. Documents should be</p>



BP 200102A

GENERAL TERMS AND CONDITIONS OF ENQUIRY

	<p>notarized or attested by a Gazetted officer. This provision for MSE will apply subject to the condition that the participating MSE meets the tender requirements.</p> <p>In case of any change in the MSE status of the bidder, it shall be the responsibility of the bidder to notify the change as a part of the bid document. If at a later date it comes to the knowledge of BHEL, that the change in the status has not been intimated by the bidder and the order is obtained under the premise of an MSE then BHEL may reject the bid or, as the case may be, cancel the order and take necessary steps for suspension of the business dealing against the bidder as per the extant guidelines for suspension of business dealings with suppliers/ contractors of BHEL.</p> <p>In case if all the items being procured under the enquiry fall under category of reserved items as defined in "Public Procurement Policy for Micro and Small Enterprises (MSEs) Order, 2012" and if any of the MSE bidder(s) is techno-commercially qualified then the price bids of only MSE bidders shall be opened. If no MSE bidder is techno-commercially qualified, then price bids of all techno-commercially qualified bidders shall be opened.</p>																								
30	<p>Integrity Pact (IP) — Independent external monitors (IEM) For tenders in which integrity pact is applicable, following points stand valid :</p>																								
A	<p>IP is a tool to ensure that activities and transactions between the company and its bidders/contractors are handled in a fair, transparent and corruption free manner. A panel of Independent External Monitors (IEMs) have been appointed to oversee implementation of IP in BHEL.</p> <p>The IP as enclosed with the tender is to be submitted (duly signed by authorized signatory who signs in the offer) along with techno commercial bid. Only those bidders who have entered into such an IP with BHEL would be competent to participate in the bidding. In other words, entering into this pact would be a preliminary qualification.</p> <p>Name: ----- Address: ----- E-mail : -----</p> <p style="text-align: right;">} As indicated in NIT / enquiry</p>																								
B	<p>Please refer section 8 of the IP for roles and responsibilities of IEMs. In case of any complaint arising out of tendering process, the matter may be referred to the IEM mentioned in the tender.</p> <p>NOTE: No routine correspondence shall be addressed to the IEM (phone / post/e-mail) regarding the clarifications, time extensions or any other administrative queries, etc. on the tender issued. All such clarifications/ issues shall be addressed directly to the tender issuing (procurement) department.</p> <p>For all clarifications/ issues related to the tender, please contact:</p> <table border="1" style="width: 100%; border-collapse: collapse;"> <thead> <tr> <th style="width: 60%;"></th> <th style="width: 20%;">(1)</th> <th style="width: 20%;">(2)</th> </tr> </thead> <tbody> <tr> <td>Name</td> <td></td> <td></td> </tr> <tr> <td>Landline No.</td> <td></td> <td></td> </tr> <tr> <td>Mobile No.</td> <td></td> <td></td> </tr> <tr> <td>Email</td> <td></td> <td></td> </tr> <tr> <td>Dept.</td> <td></td> <td></td> </tr> <tr> <td>Address</td> <td></td> <td></td> </tr> <tr> <td>Fax</td> <td></td> <td></td> </tr> </tbody> </table>		(1)	(2)	Name			Landline No.			Mobile No.			Email			Dept.			Address			Fax		
	(1)	(2)																							
Name																									
Landline No.																									
Mobile No.																									
Email																									
Dept.																									
Address																									
Fax																									
31	<p>Fraud Prevention Policy : The Bidder along with its associate/ collaborators/ sub-contractors/ sub-bidders/ consultants/ service providers shall strictly adhere to BHEL Fraud Prevention Policy displayed on BHEL website www.bhel.com and shall immediately bring to the notice of BHEL Management about any fraud or suspected fraud as soon as it comes to their notice.</p>																								
32	<p>Integrity Commitment: The offers of the bidders who are under suspension as also the offers of the bidders, who engage the services of the banned firms, shall be rejected. The list of banned firms is available on BHEL website www.bhel.com.</p> <p>Integrity commitment, performance of the contract and punitive action thereof :</p>																								
A	<p>Commitment by BHEL: BHEL commits to take all measures necessary to prevent corruption in connection with the tender process and execution of the contract. BHEL will during the tender process treat all bidder(s) in a transparent and fair manner, and with equity.</p>																								
B	<p>Commitment by bidder / Supplier / Contractor :</p>																								
B1	<ul style="list-style-type: none"> - The bidder / supplier / contractor commit to take all measures to prevent corruption and will not directly or indirectly influence any decision or benefit which he is not legally entitled to nor will act or omit in any manner which tantamount to an offence punishable under any provision of the Indian Penal code, 1860 or any other law in force in India. - The bidder / supplier / contractor will, when presenting his bid, disclose any and all payments he has made, and is committed to or intends to make to agents, brokers or any other intermediaries in connection with the award of the contract and shall adhere to relevant guidelines issued from time to time by govt. of India / BHEL - The bidder / supplier / contractor will perform / execute the contract as per the contract terms & conditions and will not default without any reasonable cause, which causes loss of business / money / reputation to BHEL. 																								



BP 200102A

GENERAL TERMS AND CONDITIONS OF ENQUIRY

B2	If any bidder / supplier / contractor during pre-tendering / tendering / post tendering / award / execution / post-execution stage indulges in mal-practices, cheating, bribery, fraud or / and other misconduct or formation of cartel so as to influence the bidding process or influence the price or acts or omits in any manner which tantamount to an offence punishable under any provision of the Indian Penal Code, 1860 or any other law in force in India, then action may be taken against such bidder / supplier / contractor as per the extant guidelines of the company available on www.bhel.com and / or under applicable legal provisions.
B3	<p>Preventive checks to eliminate suspected cartel formation between suppliers The Bidder declares that they will not enter into any illegal or undisclosed agreement or understanding, whether formal or informal with other Bidder(s). This applies in particular to prices, specifications, certifications, subsidiary contracts, submission or non-submission of bids or any other actions to restrict competitiveness or to introduce cartelization in the bidding process. In case, the Bidder is found having indulged in above activities, suitable action shall be taken by BHEL as per extant policies/ guidelines</p> <p>Declaration by Bidders We declare that the following family firms or sister concern affiliates/ subsidiary firms are participating in the tender No _____</p> <p>1.0 _____ 2.0 _____ 3.0 _____</p> <p>I _____ hereby declare on behalf of M/s _____ and family firms or sister concern affiliates/ subsidiary firms listed above that we are not indulging in cartel formation for Enquiry No _____.</p> <p style="text-align: right;">(_____) For M/s _____ Seal and Sign</p>
33	<p>Public Procurement (Preference to Make in India), Order 2017 For this procurement, Public Procurement (Preference to Make in India), Order 2017 Dtd 15.06.2017 and 28.05.2018 and subsequent orders issued by both DPIIT and the respective nodal ministries shall be applicable For this procurement, the local content to categorise a supplier as a Class I local supplier/ Class II local supplier / Non-Local supplier is as defined in Public Procurement (Preference to Make in India), Order 2017 dated 04.06.2020 issued by DPIIT. In case of subsequent orders issued by the nodal ministry changing the definition of local content for the items of the NIT, the same shall be applicable even if issued after issue of this NIT, but before opening of Part-II bids against this NIT.</p> <p>Bidder to mention the percentage of local content and place of value addition to manufacture these items in the tender.</p>
34	RESTRICTION UNDER RULE 144 (xi) OF THE GENERAL FINANCIAL RULES 2017: As per latest government guidelines
I	Any bidder from a country which shares a land border with India will be eligible to bid in this tender only if the bidder is registered with the competent authority.
II	“Bidder” (including the term ‘tenderer’, ‘consultant’ or service provider’ in certain contexts means any person or firm or company , including any member of a consortium or joint venture (that is an association of several persons , or firms or companies) every artificial juridical person not falling in any of the description of bidders stated hereinbefore, including any agency, branch or office controlled by such person, participating in procurement process.
III	Bidder from a country which shares a land border with India” for the purpose of this order means: - <ol style="list-style-type: none"> An entity incorporated, established or registered in such a country; or A subsidiary of an entity incorporated, established or registered in such a country; or An entity substantially controlled through entities incorporated, established or registered in such a county; or An entity whose beneficial owner is situated in such a country; or An Indian (or other) agent of such an entity; or A natural person who is a citizen of such a country; or A consortium or joint venture where any member of the consortium or joint venture falls under any of the above.



BP 200102A

GENERAL TERMS AND CONDITIONS OF ENQUIRY

IV	<p>The beneficial owner for the purpose of (iii) above will be as under:</p> <ol style="list-style-type: none">1. In case of company or Limited Liability Partnership, the beneficial owner is the natural person(s), who, whether acting alone or together, or through one or more juridical person, has a controlling ownership interest or who exercises control through other means. <p>Explanation –</p> <ol style="list-style-type: none">a. “Controlling ownership interest” means ownership of or entitlement to more than twenty-five per cent of shares or capital or profits of the company.b. “Control” shall include the right to appoint majority of the directors or to control the management or policy decisions including by virtue of their shareholding or management rights or shareholder’s agreements or voting agreements. <ol style="list-style-type: none">2. In case of a partnership firm, the beneficial owner is the natural person(s) who, whether acting alone or together, or through one or more juridical person, has ownership of entitlement to more than fifteen percent of capital or profits of the partnership;3. In case of an unincorporated association or body of individuals, the beneficial owner is the natural person(s), who, whether acting alone or together, or through one or more juridical person, has ownership of or entitlement to more than fifteen percent of the property or capital or profits of such association or body of individuals;4. Where no natural person is identified under (1) or (2) or (3) above, the beneficial owner is the relevant natural person who holds the position of senior managing official;5. In case of a trust, the identification of beneficial owner(s) shall include identification of the author of the trust, the trustee, the beneficiaries with fifteen percent or more interest in the trust and any other natural person exercising ultimate effective control over the trust through a chain of control or ownership.
V	<p>An Agent is a person employed to do any act for another, or to represent another in dealings with third person.</p>
VI	<p>Model certificate for Tenders</p> <p><i>“I have read the clause regarding restrictions on procurement from a bidder of a country which shares a land border with India; I certify that this bidder is not from such a country or, if from such a country, has been registered with the competent authority. I hereby certify that this bidder fulfills all requirements in this regards and is eligible to be considered. [Where applicable , evidence of valid registration by the Competent Authority shall be attached].”</i></p>

Note:

- 1.0 Tender Specific conditions shall override relevant provisions of this GTC
- 2.0 In the event of any change as notified by Govt. of India same will supersede.

