

**BHARAT HEAVY ELECTRICALS LTD., BHOPAL**  
**MATERIAL MANAGEMENT(EM)**  
**PIPLANI – BHOPAL – 462 022 (M.P)**  
**PHONE : + 91 755 250 5785**  
**e-mail:- adarshkc@bhel.in, akumar1@bhel.in**

**OPEN TENDER NOTICE No. : MEX/22-23/E1523019**

Tenders in two part bid system are invited for supply of the following items. Complete tender document can be downloaded from BHEL website <http://www.bhel.com> & BHEL e-procurement website <https://eprocurebhel.co.in/nicgep/app>. **The tender should be submitted before 03.00 PM of 23/05/2022 through** BHEL e-procurement website <https://eprocurebhel.co.in/nicgep/app>.

Note :- All enclosures are available on BHEL website <http://www.bhel.com> as well as BHEL e-procurement website <https://eprocurebhel.co.in/nicgep/app> against the above enquiry. Unregistered vendor can download the assessment form for registration from our website.

S. No	Enquiry no.	NIC Tender ID	Item	Qty.	Due date
1	E1523019	2022_BHEL_11563_1	ELASTIMOLD COMPONENTS ( 650T1 + 655BLR + 650BIP)	290 Nos.	23 <sup>th</sup> May 2022
2			ELASTIMOLD COMPONENTS ( LUG/CONNECTOR CONTACT 03700440 )	76 Nos.	
3			ELASTIMOLD COMPONENTS (655CA-N + 20MA-N) AS PER IEE386)	73 Nos.	
4			ELASTIMOLD COMPONENTS ( LUG/CONNECTOR CONTACT -03700290)	75 Nos.	
5			ELASTIMOLD COMPONENTS ( LUG/CONNECTOR CONTACT -03700310)	30 Nos.	
6			ELASTIMOLD COMPONENTS ( LUG/CONNECTOR CONTACT -03700330)	45 Nos.	
7			ELASTIMOLD COMPONENTS ( LUG/CONNECTOR CONTACT -03700380)	30 Nos.	
8			ELASTIMOLD COMPONENTS (655CA-H + 20MA-H)	80 Nos.	
9			ELASTIMOLD COMPONENTS( 655CA-J + 20MA-J)	136 Nos.	

**Note:-** All subsequent corrigendum/amendment shall be published only on our website <http://www.bhel.com> & BHEL e-procurement website <https://eprocurebhel.co.in/nicgep/app> against the enquiry no. Hence, bidders are advised to be always in touch with our website till the tender is finally opened.

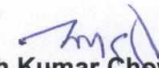
  
**Adarsh Kumar Chowdhary**  
**Dy. Manager (MEX)**  
 आदर्श कुमार चौधरी  
**ADARSH KUMAR CHOWDHARY**  
 उप प्रबंधक / Dy. Manager  
 सा.प्र.-ई.एम. /M.M.-E.M.  
 बी.एच.ई.एल., भोपाल /B.H.E.L., Bhopal





Techno-Commercial Bid  
(To be filled by supplier and submit with offer)

Tender No.		E1523019		
Item Description :		<p>IT. 1 - ELASTIMOLD COMPONENTS ( 650T1 + 655BLR + 650BIP) AS PER IEE386 AND AS PER BHEL DRG NO. 34022140084#01 REV.04. ( BUSHING WITH 2 CHECK NUTS + ELBOW + BASIC INSULATING PLUG ALONG WITH INSULATION CAP,LUBRICANT, WIPING CLOTH AND WATER SEAL TAPE FOR SEALING).</p> <p>IT. 2 -ELASTIMOLD COMPONENTS ( LUG/CONNECTOR CONTACT 03700440 ) AS PER IEE386 AND AS PER BHEL DRG NO. 34022140084#17 REV 04</p> <p>IT. 3 -ELASTIMOLD COMPONENTS (655CA-N + 20MA-N) AS PER IEE386 AND AS PER BHEL DRG NO. 34022140084#22 REV 04.</p> <p>IT. 4 - ELASTIMOLD COMPONENTS ( LUG/CONNECTOR CONTACT -03700290) AS PER IEE386 AND AS PER BHEL DRG NO. 34022140084#04 REV.04.</p> <p>IT. 5 - ELASTIMOLD COMPONENTS ( LUG/CONNECTOR CONTACT -03700310) AS PER IEE386 AND AS PER BHEL DRG NO. 34022140084#06 REV.04.</p> <p>IT. 6 - ELASTIMOLD COMPONENTS ( LUG/CONNECTOR CONTACT -03700330) AS PER IEE386 AND AS PER BHEL DRG NO. 34022140084#08 REV.04.</p> <p>IT. 7 - ELASTIMOLD COMPONENTS ( LUG/CONNECTOR CONTACT -03700380) AS PER IEE386 AND AS PER BHEL DRG NO. 34022140084#12 REV.04</p> <p>IT. 8 - ELASTIMOLD COMPONENTS (655CA-H + 20MA-H) AS PER IEE386 AND AS PER BHEL DRG NO. 34022140084#18 REV 04.</p> <p>IT.9 - ELASTIMOLD COMPONENTS( 655CA-J + 20MA-J) AS PER IEE386 AND AS PER BHEL DRG NO. 34022140084#19.REV.04.</p>		
Remarks :		<p>[1] THIS IS AN E-PROCUREMENT ENQUIRY &amp; OFFER TO BE SUBMITTED THROUGH NIC PORTAL (HTTPS://EPROCUREBHEL.CO.IN/NICGEP/APP ) ONLY . [2] REVERSE AUCTION SHALL NOT BE DONE FOR THIS ENQUIRY. [3] BHEL STD T&amp;C BP 200102, MM5527 &amp; MM5533 [AS AVAILABLE AT HTTPS://BPL.BHEL.COM] ARE APPLICABLE. [4] ALL GST PROVISIONS ARE APPLICABLE. [5] FOR INDIAN SUPPLIERS, PLEASE QUOTE FOR BHEL BHOPAL BASIS. [6] FOR FOREIGN SUPPLIERS, PLEASE QUOTE CIF NHAVA SHEVA SEAPORT BASIS. [7] EXISTING OR NEW TYPE TEST REPORT AS PER IEE386 TO BE SUBMITTED BEFORE DELIVERY. IF EXISTING TYPE TEST REPORT IS NOT OF WITHIN 5 YEARS, THEN A CERTIFICATION OF CONFORMANCE REGARDING VALIDITY OF THE DESIGN AND TYPE TEST REPORT TO BE OBTAINED FROM OEM/PRINCIPAL &amp; SUBMITTED BEFORE DELIVERY.</p>		
Sr. No.	ELEMENTS	Standards	To be offered / confirmed by supplier	Remarks, if any
1	Quotation Reference & date	As per supplier		
2	HSN / SAC code	As per supplier		
2.1	GST TYPE & ITS PERCENTAGE APPLICABLE Item wise mentioned in the offer (IGST/CGST+SGST/UGST)	As per supplier		
3	Quotation Currency	To be mentioned by supplier [ex. INR, USD, EURO etc.]		
4	E-Mail	As per supplier		
5	Phone/Mobile	As per supplier		
6	Contact Person	As per supplier		
7	Order to be placed on	As per supplier		
8	Address	As per supplier		
9	Minimum delivery period to be quoted in no of weeks from the date of receipt of Purchase Order.	As per supplier		
10	Prices shall be firm till delivery	Yes		
11	INSPECTION: As given in enquiry.	Yes		
12	(a) Delivery Destination: - For Indian Suppliers, The material is required to be supplied to FOR BHEL Bhopal with all freight charges on paid basis, duly insured & inclusive of P&F charges. (b) For Foreign suppliers, material is required on CIF Nhava Sheva Sea Port Basis inclusive of P&F charges.	Yes		
13	Quoted for all the items of tender enquiry	Yes / No. (If "No" please mention item number of regretted items)		
14	Technical Specifications	Accepted as per enquiry / Accepted with deviation (If select Accepted with deviation, please mention the deviation)		
15	Guarantee Period of Material as per clause no. 18 of BHEL GTC BP200102.	Yes		
16	TC , GC and ALL Inspection report as per tender enquiry and specification will be submitted along with each consignment.	Yes (In case of "No" your offer may be rejected).		
17	Brand Name, If any.	As per supplier		
18	Supply from	As per supplier		
19	Quotation Validity will be 90 days from the date of Technical bid opening.	Yes		
20	Are you registered under MSE as small or micro.	Yes / No (If select Yes, please enclosed valid UDYAM registration certificate)		

Name of Supplier: .....  
Sign and Seal of Supplier

Techno-Commercial Bid (To be filled by supplier and submit with offer)				
Tender No.		E1523019		
Description :		IT. 1 - ELASTIMOLD COMPONENTS ( 650T1 + 655BLR + 650BIP) AS PER IEE386 AND AS PER BHEL DRG NO. 34022140084#01 REV.04. ( BUSHING WITH 2 CHECK NUTS + ELBOW + BASIC INSULATING PLUG ALONG WITH INSULATION CAP, LUBRICANT, WIPING CLOTH AND WATER SEAL TAPE FOR SEALING). IT. 2 - ELASTIMOLD COMPONENTS ( LUG/CONNECTOR CONTACT 03700440 ) AS PER IEE386 AND AS PER BHEL DRG NO. 34022140084#17 REV 04 IT. 3 - ELASTIMOLD COMPONENTS (655CA-N + 20MA-N) AS PER IEE386 AND AS PER BHEL DRG NO. 34022140084#22 REV 04. IT. 4 - ELASTIMOLD COMPONENTS ( LUG/CONNECTOR CONTACT -03700290 ) AS PER IEE386 AND AS PER BHEL DRG NO. 34022140084#04 REV.04. IT. 5 - ELASTIMOLD COMPONENTS ( LUG/CONNECTOR CONTACT -03700310 ) AS PER IEE386 AND AS PER BHEL DRG NO. 34022140084#06 REV.04. IT. 6 - ELASTIMOLD COMPONENTS ( LUG/CONNECTOR CONTACT -03700330 ) AS PER IEE386 AND AS PER BHEL DRG NO. 34022140084#08 REV.04. IT. 7 - ELASTIMOLD COMPONENTS ( LUG/CONNECTOR CONTACT -03700380 ) AS PER IEE386 AND AS PER BHEL DRG NO. 34022140084#12 REV.04. IT. 8 - ELASTIMOLD COMPONENTS (655CA-H + 20MA-H) AS PER IEE386 AND AS PER BHEL DRG NO. 34022140084#18 REV 04. IT. 9 - ELASTIMOLD COMPONENTS (655CA-J + 20MA-J) AS PER IEE386 AND AS PER BHEL DRG NO. 34022140084#19 REV.04.		
Sr. No.	ELEMENTS	Standards	To be offered/confirmed by supplier	Remarks, if any
21	<p>(a) For Indian Suppliers-Payment terms: 100% payment within 90 days of receipt (45 days for MSE / NSIC registered suppliers under as per relevant act in force) subject to acceptance of material at BHEL. (b) For foreign suppliers-100% payment against irrevocable, unconfirmed LC, payable within 90 days of the Bill of Lading (B/L) date or Payment terms of CAD payable on 90th day of B/L / AWB. [Note:-Any deviation from the above payment terms, if accepted (by BHEL), shall be loaded @ SBI base rate + 6% for the purpose of bid evaluation.]</p> <p>Important note: An MSE enterprises who are traders/agent/dealer shall not be benefitted under public procurement. Therefore, no benefit including terms of payment within 45 days shall be passed on to MSE vendor who are trader, dealer and agent. If you are not an "original manufacturer" of indented product against above enquiry, please accept the payment terms as " 100% payment in 90 days after receipt &amp; acceptance of material at BHEL". In case of non-acceptance or any deviation from the above payment terms, if accepted (by BHEL), shall be loaded @ SBI base rate + 6% for the purpose of bid evaluation.</p>	90 days / 45 Days (If supplier is MSE, please select 45 days and if supplier is non -MSE or Trader/Dealer/Agent, please select 90 days)		
22	Other Charges (If any)	Applicable / Not Applicable. (If applicable please mention percentage (%) / Value (along with type of charges).		
23	Transit Insurance will be in supplier scope	Yes		
24	Penalty: - LD shall be 0.5% of the total order value per week of delay or part thereof, subject a maximum of 10% of the total order value (Please refer clause 9 of GCC - BP200102).	Yes / No (In case of "No", your offer will be loaded suitably)		
25	Acceptance of General Terms and Conditions of enquiry (Form No. BP- 200102) & BHEL P.O. Terms & Conditions (Indigenous) MM5527 & BHEL P.O. Terms & Conditions (Foreign) MM5533 (available at <a href="https://BPLBHEL.COM">HTTPS://BPLBHEL.COM</a> ).	Yes (In case of "No" your offer may be rejected).		
26	EXISTING OR NEW TYPE TEST REPORT AS PER IEE386 TO BE SUBMITTED BEFORE DELIVERY. IF EXISTING TYPE TEST REPORT IS NOT OF WITHIN 5 YEARS, THEN A CERTIFICATION OF CONFORMANCE REGARDING VALIDITY OF THE DESIGN AND TYPE TEST REPORT TO BE OBTAINED FROM OEM/PRINCIPAL & SUBMITTED BEFORE DELIVERY.	Yes		
27	Kindly confirm whether other family firms or sister concern affiliates / subsidiary firms are participating in the same tender, so as to eliminate the possibility of cartel formation. (if yes kindly attach filled, sign & sealed copy of Annexure-IX).	Kindly attach 'Annexure -IX' with seal & sign.		
28	Confirm whether bidder is Manufacturer or Trader or Dealer or Agent of items under enquiry. In case of Trader or Dealer or Agent, please furnish authorization certificate from OEM.	As per supplier		
29	I/We hereby certify that the quoted item(s) offered by us in this enquiry is /are having local content (in %) of	As per supplier		
29.1	I/We hereby certify that the local content % certified above is in line with definition of local content given in Public Procurement (Preference to Make in India), Order 2017 Dtd. 4-6-2020 and I/We qualify as (Class - I/Class II/Non-Local supplier - Fill in one which is applicable).	As per supplier (Class I -- Equal to or more than 50%, Class II -- More than 20% but less than 50%, Non - Local -Less than or equal to 20%.) [NOTE: Please provide Certification regarding local content on your letter head for the quoted items with seal & sign.]		
29.2	Address of location at which the local value addition is made:	As per supplier		
29.3	By filling "Yes" in adjacent Box, I hereby declare & confirm that the details furnished above are true and correct to the best of my knowledge and belief and I undertake to inform you of any changes therein immediately. In case any of the above information is found to be false or untrue or misleading or misrepresenting, I am aware that I may be held liable for it.	Yes / No		

- 1) Deviation in any commercial condition shall be suitably loaded in the offered price.
- 2) In case of any conflict, confirmation by vendor provided here will supersede.
- 3) In case bidder is not making an offer against this enquiry, we request the bidder to post the regret letter

Name of Supplier:.....

Seal & Sign of supplier

DRG. NO. 3 402 21 40084

ELASTIMOLD COMPONENT DETAILS

ELASTIMOLD COMPONENT DETAILS

IT.NO.	DESCRIPTION	CATELOGE NO.	CABLE SIZE mm <sup>2</sup> /O/D ⊕	REMARK	STYLE NO.	WEIGHT (K.G.)
01	BUSHING WITH 2 CHECK NUTS + ELBOW + BASIC INSULATING PLUG ALONG WITH INSULATION CAP, LUBRICANT, WIPING CLOTH AND WATER SEAL TAPE FOR SEALING	650 T1+655 BLR+650 BIP	-	COMMON COMPONENTS TO ALL TYPE OF CABLES	BP9043035874	4.40
02	CONNECTING PLUG	650 CP	-	COMMON COMPONENTS TO ALL TYPE OF CABLES	BP9043035882	1.10
03	LUG/CONNECTOR CONTACT	03700280	150 mm <sup>2</sup>	COMPONENTS DEPENDING ON TYPE/SIZE OF CABLES	BP9043035891	0.30
04	LUG/CONNECTOR CONTACT	03700290	185 mm <sup>2</sup>	COMPONENTS DEPENDING ON TYPE/SIZE OF CABLES	BP9043035904	0.30
05	LUG/CONNECTOR CONTACT	03700300	185 mm <sup>2</sup>	COMPONENTS DEPENDING ON TYPE/SIZE OF CABLES	BP9043035912	0.30
06	LUG/CONNECTOR CONTACT	03700310	185 mm <sup>2</sup>	COMPONENTS DEPENDING ON TYPE/SIZE OF CABLES	BP9043035921	0.30
07	LUG/CONNECTOR CONTACT	03700320	240 mm <sup>2</sup>	COMPONENTS DEPENDING ON TYPE/SIZE OF CABLES	BP9043035939	0.30
08	LUG/CONNECTOR CONTACT	03700330	240-300 mm <sup>2</sup>	COMPONENTS DEPENDING ON TYPE/SIZE OF CABLES	BP9043035947	0.30
09	LUG/CONNECTOR CONTACT	03700340	300 mm <sup>2</sup>	COMPONENTS DEPENDING ON TYPE/SIZE OF CABLES	BP9043035955	0.30
10	LUG/CONNECTOR CONTACT	03700350	300 mm <sup>2</sup>	COMPONENTS DEPENDING ON TYPE/SIZE OF CABLES	BP9043035963	0.30
11	LUG/CONNECTOR CONTACT	03700360	400 mm <sup>2</sup>	COMPONENTS DEPENDING ON TYPE/SIZE OF CABLES	BP9043035971	0.35
12	LUG/CONNECTOR CONTACT	03700380	400 mm <sup>2</sup>	COMPONENTS DEPENDING ON TYPE/SIZE OF CABLES	BP9043035980	0.35
13	LUG/CONNECTOR CONTACT	03700390	400 mm <sup>2</sup>	COMPONENTS DEPENDING ON TYPE/SIZE OF CABLES	BP9043035998	0.35
14	LUG/CONNECTOR CONTACT	03700400	500 mm <sup>2</sup>	COMPONENTS DEPENDING ON TYPE/SIZE OF CABLES	BP9043036005	0.35
15	LUG/CONNECTOR CONTACT	03700410	500 mm <sup>2</sup>	COMPONENTS DEPENDING ON TYPE/SIZE OF CABLES	BP9043036013	0.35

IT.NO.	DESCRIPTION	CATELOGE NO.	CABLE SIZE mm <sup>2</sup> /O/D ⊕	REMARK	STYLE NO.	WEIGHT (K.G.)
16	LUG/CONNECTOR CONTACT	03700420	630 mm <sup>2</sup>	COMPONENTS DEPENDING ON TYPE/SIZE OF CABLES	BP9043036021	0.35
17	LUG/CONNECTOR CONTACT	03700440	630 mm <sup>2</sup>	COMPONENTS DEPENDING ON TYPE/SIZE OF CABLES	BP9043036030	0.35
18	CABLE ADAPTOR AND SHIELD EARTHING ADAPTOR	655CA-H+20 MA-H	21.6-26.7 mm	COMPONENTS DEPENDING ON TYPE/SIZE OF CABLES	BP9043036048	0.55
19	CABLE ADAPTOR AND SHIELD EARTHING ADAPTOR	655CA-J+20 MA-J	24.9-30.0 mm	COMPONENTS DEPENDING ON TYPE/SIZE OF CABLES	BP9043036056	0.55
20	CABLE ADAPTOR AND SHIELD EARTHING ADAPTOR	655CA-L+20 MA-L	30.0-37.2 mm	COMPONENTS DEPENDING ON TYPE/SIZE OF CABLES	BP9043036064	0.55
21	CABLE ADAPTOR AND SHIELD EARTHING ADAPTOR	655CA-M+20 MA-M	34.8-41.5 mm	COMPONENTS DEPENDING ON TYPE/SIZE OF CABLES	BP9043036072	0.55
22	CABLE ADAPTOR AND SHIELD EARTHING ADAPTOR	655CA-N+20 MA-N	38.5-45.2 mm	COMPONENTS DEPENDING ON TYPE/SIZE OF CABLES	BP9043036081	0.55
23	ELBOW	655BLR	-	ALL TYPE CABLES	BP9043036099	1.60
24	BUSHING WITH 2 CHECK NUTS	650 T1	-	ALL TYPE CABLES	BP9043036684	2.20
25	BASIC INSULATING PLUG ALONG WITH INSULATION CAP	650 BIP	-	ALL TYPE CABLES	BP9043036692	0.60

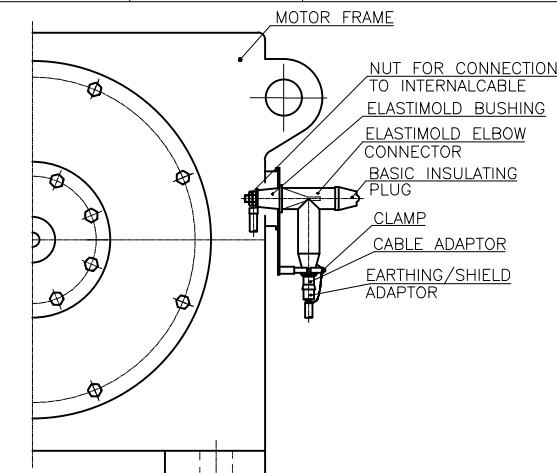

⊕ CABLE O/D IS THE INDIVIDUAL CORE DIA. OVER INSULATION.

REV.	DATE	ALTERED RV
04	03.02.20	CHECKED USR

ADDITIONAL INFORMATION  
STANDARD

STATUS OF DRAWING  
DRAWING TITLE CORRECTED.

DISTRIBUTION OF PRINTS  
AME - 1 TEX-3

TYPE OF PRODUCT OR NAME OF CUSTOMER/PROJECT  
STANDARD

BHARAT HEAVY ELECTRICALS LTD. BHOPAL

DRN	NAME	SIGN.	DATE	73 74 NO. OF VAR.
CHD.	RV	-Sd-	21.09.2010	
APPD	AKB	-Sd-	21.09.2010	

REV.	DATE	ALTERED LP	REV.	DATE	ALTERED RV	REV.	DATE	ALTERED RV
03	19.11.16	CHECKED USR	02	27.02.16	CHECKED USR	01	08.12.10	CHECKED AKB

WEIGHT ADDED. ITEM 24 & 25 ADDED. ITEM 23 AND VIEW ADDED.

DEPT. AME GRADE OF UN. TOL. DIM. C/M/F SCALE NTS WEIGHT(Kg.) REF. TO ASSY. DRG. ITEM NO. 75 77 NO. OF ITEMS

TITLE ELASTIMOLD COMPONENT 1 CARD CODE 3 7 DRAWING NO. 3 402 21 40084 22 23 24 REV 04 SHEET NO. 01 NO. OF SHEETS 01

THE INFORMATION ON THIS DOCUMENT IS THE PROPERTY OF BHARAT HEAVY ELECTRICALS LIMITED IT MUST NOT BE USED DIRECTLY OR INDIRECTLY IN ANY WAY DETRIMENTAL TO THE INTEREST OF THE COMPANY.

REF. DRG. NO.

SIGN & DATE

INVENTORY NO.

RV/ADAP./34022140084

**Letter head of Company (<Rs. 10 Cr value)**

Ref. ....

Date .....

To

Bharat Heavy Electricals Limited  
Piplani, Bhopal-462022

**Subject: - Certification regarding local content**

Reference: Tender Enquiry No-.....

Name of item(s): .....

Dear Sir,

We hereby certify that the quoted items offered by us against Enquiry No ..... is having local content of .....%.

Further, to certify that the local content % certified above is in line with definition of Local content given in point no 2 of Public Procurement (Preference to Make in India), Order 2017 and we qualify as..... (Class-I/ CLASS-II/ Non-Local supplier - fill in one which is applicable) local supplier.

We further confirm that details of location at which the local value addition is made will be at ..... (address of the works).

The above declaration does not include services such as transportation, insurance, installation, commissioning, training and after sales service support like AME/CMC etc. as local value addition.

We also understand, false declarations will be in breach of the Code of Integrity under Rule 175(1) (i) (h) of the General Finance Rules for which a bidder or its successors can be debarred for up to two years as per Rule 151 (iii) of the General Finance Rules along with such other actions as may be permissible under law.

I hereby declare that the details furnished above are true and correct to the best of my knowledge and belief, and I undertake to inform you of any changes therein, immediately. In case any of the above information is found to be false or untrue or misleading or misrepresenting, I am aware that I may be held liable for it.

Yours very truly,

..... (authorized signatory of company with seal)

..... (firm name)

Authorized signatory  
of company

DECLARATION BY VENDOR

We declare that the following family firms or sister concern affiliates / subsidiary firms are participating in the tender No E.....:

1.0 .....

2.0 .....

3.0 .....

.....

I ....., hereby declare on behalf of M/s ..... and the family firms or sister concern affiliates / subsidiary firms listed above that we are not indulging in cartel formation for Enquiry No E.....

(.....)

For M/s .....

(Seal & Sign)



## Company Letter head

Date: {insert date}

To,  
Bharat Heavy Electricals Limited  
Piplani  
Bhopal-462023  
Madhya Pradesh  
India

I/We hereby certify (for the period from\* \_\_\_\_\_ to \_\_\_\_\_) that,

1. {Name of company} (Vendor Code with BHEL) is a company incorporated on {insert date}{insert date} under the {Law of the Country}
2. It is a tax resident as per the Tax Laws of {country}.
3. The Company does not have and is not likely to have a permanent establishment in India as defined in Article 5 of the Agreement for Avoidance of Double Taxation between India and \_\_\_\_\_ ("the tax treaty" for short).
4. In this regard, it is further confirmed that:
  - the Company does not have or is not likely to have a fixed place of business in India through which its business is wholly or partly conducted as stipulated in Article 5 of the tax treaty
  - the Company does not have or is not likely to have any dependent agent in India as stipulated in Article 5 of the tax treaty
5. The company does not have any business connection in India as per Sec 9(1) of the Indian Income Tax Act 1961 through which business is carried on in India.

I hereby declare that the above information is correct and complete to the best of my knowledge and belief. Further I undertake to promptly inform the Company (i.e. BHEL) in writing should there be any change in the facts given above.

I/We, my/our legal heirs, executors and administrators hereby indemnify and keep indemnified the Company (i.e. BHEL) for any loss (including but not limited to tax, interest and penalty) suffered by as a result of the Company (i.e. BHEL) relying on this declaration and/or my delay/default in confirming the change, if any, in the facts mentioned above. This obligation shall be in force at all times.

This certificate is being issued to the Customer / Client / Payee to enable them to decide upon the With Holding Tax applicable on transaction with our company.

If there is any change in the above facts the same would be intimated to you.

For& On behalf of

{Insert name of the company}

Authorized Signatory with Seal

\*The period can be decided by the issuer & no fresh certificate will be asked for releasing payment within this period.

## Company Letter head

Date: {insert date}

To,  
Bharat Heavy Electricals Limited  
Piplani  
Bhopal-462023  
Madhya Pradesh  
India

I/We hereby certify (for the period from \*\_\_\_\_\_ to \_\_\_\_\_) that,

1. {Name of company} (Vendor Code with BHEL) is a company incorporated on {insert date}{insert date} under the {Law of the Country}
2. It is a tax resident as per the Tax Laws of {country}.
3. The Company has its permanent establishment in India as defined in Article 5 of the Agreement for Avoidance of Double Taxation between India and \_\_\_\_\_("the tax treaty" for short).  
**And/or**
4. the Company has a fixed place of business in India through which its business is wholly or partly conducted as stipulated in Article 5 of the tax treaty  
**And/or**
5. the Company has agent(not of independent status) in India as stipulated in Article 5 of the tax treaty  
**And/or**
6. The company has business connection in India as per Sec 9(1) of the Indian Income Tax Act 1961 through which its business is carried on in India.

**But as far as our business dealing with your organization is concerned we are not using this permanent establishment and business connections and we are dealing directly from our office situated in \_\_\_\_\_.**

I hereby declare that the above information is correct and complete to the best of my knowledge and belief. Further I undertake to promptly inform the Company (i.e. BHEL) in writing should there be any change in the facts given above.

I/We, my/our legal heirs, executors and administrators hereby indemnify and keep indemnified the Company (i.e. BHEL) for any loss (including but not limited to tax, interest and penalty) suffered by as a result of the Company (i.e. BHEL) relying on this declaration and/or my delay/default in confirming the change, if any, in the facts mentioned above. This obligation shall be in force at all times.

This certificate is being issued to the Customer / Client / Payee to enable them to decide upon the With Holding Tax applicable on transaction with our company.

If there is any change in the above facts the same would be intimated to you.

For & On behalf of

{Insert name of the company}

Authorized Signatory with Seal

\*The period can be decided by the issuer & no fresh certificate will be asked for releasing payment within this period.



BP 200102

## GENERAL TERMS AND CONDITIONS OF ENQUIRY

Sl.No.	Description
1	<b>General:</b>
A	These General terms & conditions (GTC) shall apply to all enquiries, notice inviting tenders, request for quotations concerning the supply of goods and / or rendering of services to Bharat Heavy Electricals Ltd., Bhopal (hereinafter referred to as BHEL or the Purchaser) or its Projects / Customers. Special / supplementary enquiry conditions, if any, will override the conditions in this annexure.
2	<b>General Instructions - Common for Indigenous &amp; Foreign enquiries</b>
A	<b>Through E- procurement</b>
A1	<ol style="list-style-type: none"><li>Offer shall be submitted by the bidders in single/two parts as called in Tender enquiry. Bid Part - I Technical cum Commercial bid Bid Part - II Price bid</li><li>Suppliers shall quote <b>price</b> on BHEL authorised third party service provider <b>e-procurement site</b>. Any deviation from the price format shall be clearly brought out in the offer Bid part I.</li></ol> <p>The offer shall be uploaded on BHEL e-procurement site using Class III digital signature. <b>Bidders to put sign and seal on all the uploaded documents.</b> The quotation should be uploaded on the site before due date and time.</p> <p>Part-I of the bid shall contain complete item-wise scope of supply as offered vis-à-vis the scope of supply as per enquiry, all commercial terms and conditions etc. It is expected that bidders shall meet all our technical and commercial requirements and shall not deviate from them.</p>
B	<b>Through tender room</b>
B1	Sealed bids are invited for scope of Supply / Services as detailed in the enquiry. The quotation should be neatly typed and free from over writing/ erasures. Any correction or addition must be authenticated. The bid should be submitted in English or Hindi language. Relevant enclosures, supporting documents, catalogue, samples, if any, as required as per Notice Inviting Tender (NIT) conditions shall be sent along with technical offer. Rate should be quoted in the units asked for in the enquiry. The rates should be quoted both in figures and words. In case of discrepancy in figures and words, the rates quoted in words shall be considered.
B2	Bids shall be submitted in a Sealed cover with Enquiry No., Due date and Bidder's name indicated on the cover. In case of Two part Bid, technical bid containing technical offer, this GTC duly filled-in & signed; and <b>un-priced copy</b> of the Price Bid should be kept in one envelope. Price Bid containing only the price (as called for in the price format where required) should be kept in a separate envelope. Both envelopes indicating Part —I or Part-II as the case may be to be put in a bigger envelope, which should be addressed to In charge, Tender Room, Bharat Heavy Electricals Ltd. 2 <sup>nd</sup> Floor, Jawahar Bhavan, Piplani, Bhopal 462022. Enquiry No., due date and bidder's name must be mentioned on all envelopes. Offer must reach tender room of BHEL Bhopal latest by 11.00 am IST on the enquiry due date. Bids submitted as single part bid against two – part bid, shall be rejected unless the offer is techno-commercially acceptable without seeking any clarification.
B3	Offer received after 11.00 AM IST of the due date will be termed as "Late" and shall not be considered. However, late offer received against single tender enquiry may be considered.
B4	Bidder can also submit offer through email, if called for in the enquiry, at the email address indicated in the enquiry. Such email offers shall be sent only on designated email-id to reach before 11.00 am IST on the tender due date. BHEL will not be responsible for incomplete offers and the ones delivered late through e-mail.
C	Commercial Conditions quoted by the vendor in any place including as stated in bidder's 'General Terms and Conditions' if any, shall not be binding on the Purchaser and the conditions contained in this annexure, including special conditions, if any, for this enquiry shall only prevail.
D	BHEL reserves the right to go for Reverse Auction (RA) (Guidelines as available on <a href="http://www.bhel.com">www.bhel.com</a> ) instead of opening the sealed envelope price bid, submitted by the bidder. This will be decided after techno-commercial evaluation. Bidders to give their acceptance with the offer for participation in RA. Non-acceptance to participate in RA may result in non-consideration of their bids, in case BHEL decides to go for RA. Those bidders who have given their acceptance to participate in Reverse Auction will have to necessarily submit 'Process compliance form' (to the designated service provider) as well as 'Online sealed bid' in the Reverse Auction. Non-submission of 'Process compliance form' or 'Online sealed bid' by the agreed bidder(s) will be considered as tampering of the tender process and will invite action by BHEL as per extant guidelines for suspension of business dealings with suppliers/ contractors (available on <a href="http://www.bhel.com">www.bhel.com</a> ). The bidders have to necessarily submit online sealed bid less than or equal to their envelope sealed price bid already submitted to BHEL along with the offer. The envelope sealed price bid of successful L1 bidder in RA, if conducted, shall also be opened after RA and the order will be placed on lower of the two bids (RA closing price /envelope-sealed price)



BP 200102

## GENERAL TERMS AND CONDITIONS OF ENQUIRY

	<p>thus obtained. The bidder having submitted this offer specifically agrees to this condition and undertakes to execute the contract on thus awarded rates.</p> <p>If it is found that L1 bidder has quoted higher in online sealed bid in comparison to envelope sealed bid for any item(s), the bidder will be issued a warning letter to this effect. However, if the same bidder again defaults on this count in any subsequent tender in the unit, it will be considered as fraud and will invite action by BHEL as per extant guidelines for suspension of business dealings with suppliers/ contractors (available on <a href="http://www.bhel.com">www.bhel.com</a>).</p> <p>In case RA fails, sealed/E-proc price bids shall be opened in line with RA Guidelines. In case BHEL decides to open the sealed paper price bids, bids of all the techno-commercially acceptable bidders will be opened on the assigned date.</p>
E	The goods offered shall conform to BHEL specifications and / or National/International standards as mentioned in the Enquiry and the bidder is required to confirm his unconditional acceptance to the same. Vendors, seeking deviations from the specifications and any other conditions, may indicate the same clearly on a separate sheet, with reasons for such deviations. BHEL reserves the right to reject the offer with deviations or load the deviations suitably for evaluation.
F	Offers shall be submitted directly by vendor or his authorized agent only. Unsolicited offers shall be summarily rejected.
G	Bid in single part or techno-commercial bid in <b>two-part</b> system (as the case may be) will be opened on the due date. In case of two part bid, price bids of techno-commercially acceptable bidder(s) only shall be opened on the assigned date, for which separate intimation will be sent to the acceptable bidders.
H	The bidder whose bid is technically not accepted will be informed & EMD wherever submitted shall be returned along with his price bid within <i>30 days</i> of contract finalization date. No interest will be payable on EMD amount. EMD shall however be forfeited in the event of bidder opting out after submission of the bid.
I	<ol style="list-style-type: none"><li>Any discount / revised offer submitted by a bidder on its own shall be considered, provided it is received on or before the due date and time of offer submission (Part-I). Conditional discounts shall not be considered for evaluation of tenders.</li><li>Unsolicited discounts / revised offers given after Part-I bid opening shall not be accepted. No change in price will be permitted within the validity period of offer.</li><li>In case of changes in scope and / or technical specification and / or commercial terms &amp; conditions, having price implication, techno-commercially acceptable bidders shall be asked by BHEL to submit the impact of such changes on their price bids. In case a bidder opts to submit revised price bid instead of impact called for, then latest price bid shall prevail. However in both situations, original price bid will be necessarily opened.</li></ol>
J	The bidders will submit Integrity Pact, duly signed by its authorized signatory, where called for in the enquiry.
K	Wherever the enquiry is issued to unregistered vendor, the bidder shall visit ' <a href="http://www.bhel.com">www.bhel.com</a> ' for submitting the online Supplier Registration Application. Price bids of such vendors, will be opened only on techno-commercial acceptance of bid & after supplier registration.
L	BHEL expects that the bidder must respond to the enquiry. Regret letter, with valid reasons for not participating in the tender will be submitted where the bidder is unable to submit offer. Repeated lack of response on the part of vendor may lead to his deletion from BHEL's approved vendor list.
M	Goods shall be properly packed to avoid transit damage. Suitable markings shall be provided to identify the goods with that of the PO No. and the consignee details.
N	Goods shall be consigned to AGM (CRX), BHEL, Piplani, Bhopal - 462022, India, unless otherwise specified in the PO.
O	In case of press tenders (i.e. those published in newspapers) all corrigenda, addenda, amendments, time extensions, clarifications etc. to the tender will be hosted on BHEL website. ( <a href="http://www.bhel.com">www.bhel.com</a> & <a href="http://www.bhelbpl.co.in">www.bhelbpl.co.in</a> ) only. Bidders responding to press tender should regularly visit website(s) to keep themselves updated.
P	In the course of evaluation, if more than one bidder happens to occupy <b>L-1</b> status and the order is to be placed on a single vendor, effective <b>L-1</b> will <b>be</b> decided in the order of availability of goods from Indigenous sources, suitability of delivery period to BHEL's requirements, vendor performance rating and quantum of past business volumes with the vendor in last 3 years, preceding the current financial year, for the same item. BHEL's decision in such situations shall be final and binding.
Q	The Purchaser can consider awarding tendered quantities among more than one bidder (after acceptance of LI price by the other bidders) in the manner and proportion disclosed in the tender conditions. Purchaser can also consider awarding of part of the tendered quantity to other than L-1 bidder at <b>LI</b> counter offered rates, if the quantity offered by the L-1 bidder is less than the quantity tendered for.
R	The bidder shall submit price bid strictly in the price format, wherever provided for, in the enquiry. Any attempt on the part of the bidder to alter the contents of the price bid format in any manner, which in the opinion of BHEL can vitiate the tendering process, will lead to rejection of the bid, <b><u>besides BHEL taking appropriate punitive action as deemed fit.</u></b>
3	<b>Delivery Terms</b>
A	<b>Indigenous Purchase</b>



BP 200102

**GENERAL TERMS AND CONDITIONS OF ENQUIRY**

A1	Goods shall be delivered on 'FOR Destination' basis to the named destination unless otherwise called for in the enquiry.	
B	<b>Foreign Purchase — Imports</b>	
B1	<ol style="list-style-type: none"> <li>Goods shall be despatched by Sea, unless stated otherwise in the enquiry or purchase order.</li> <li>Terms of Delivery for Sea shipment shall be on CFR / CIF basis with 14 days' detention free period preferably at Dry Port - ICD Mandideep (INMDD6) for FCL (Full Container Load) Cargo of GP &amp; HC Containers.</li> <li>For other cases - Other than GP &amp; HC Containers, LCL Cargo shall be delivered at Nhava Sheva (JNPT) &amp; Break-bulk Cargo at Mumbai (MPT).</li> <li>For Air consignments, the terms of delivery shall be FCA at BHEL nominated Airport.</li> <li>Freight amount shall be indicated separately in the offer in case of CIP/CFR/CIF.</li> <li>The number of detention free days and destination charges payable to shipping line must be mentioned in your offer and also on the Bill of Lading.</li> <li>Offer received on FOB basis may be considered on an exceptional basis. BHEL will load freight, marine insurance &amp; shipping line port handling charges etc to work out landed cost at Sea Port.</li> <li>Please visit BHEL Bhopal website <a href="http://www.bhelbpl.co.in">www.bhelbpl.co.in</a> for details of named Air ports and Sea ports. Name of the gateway port so chosen by the Seller shall be indicated by the Bidder in his offer.</li> </ol>	
B2	<ol style="list-style-type: none"> <li>For delivery of FCL (Full Container Load) cargo, the Bidder shall provide minimum <b>14 days' detention free period</b> from the date of delivery at Port of Discharge / Place of Delivery (in case of ICD). Wherever the detention free period offered is less than 14 days, the bids shall be <b>loaded</b> for the period short of 14 days' period.</li> <li><u>Port Congestion charges or any additional charges claimed by the shipping line at Port of Discharge / Place of Delivery shall be to the Seller's account.</u></li> </ol>	
4	<b>Vendor's particulars &amp; logistics information (Bidder to give details against each of the provisions)</b>	
A	Name of the vendor's executive to deal with this tender / project	
B	E-mail address of the contact person	
C	Telephone no. of the contact person	
D	Name of location from where the goods shall be offered for inspection and dispatch	
5	<b>Additional logistics information for Imports</b>	
A	Bid currency	
B	Charges applicable at discharge port up to BHEL's CFS (Container Freight Station) to be indicated in your offer and on the B/L	
C	Name of Airport in the country of dispatch for FCA delivery terms	
D	Estimated number, type & size of containers for delivery of tendered quantity (applicable where the goods are to be sent in FCL)	
E	No. of packages with cumulative gross weight and CBM volume (applicable for LCL & Break-bulk shipment)	
F	Approx. distance in km. from Vendor's works to Port of Loading	Sea port /Air port
6	<b>Delivery Schedule &amp; Completion date</b>	
A	<ul style="list-style-type: none"> <li>Instead of writing specific date against delivery offered, bidder shall commit delivery period in number of days / weeks/ months to suit the delivery period indicated in the enquiry.</li> <li>Commencement of delivery period shall be reckoned from the date of PO / LOI or any other agreed milestone.</li> <li>Seller shall deliver the goods in the manner and schedule agreed under the Purchase order.</li> <li>Goods shall be delivered within contractual period or any extension thereof, if any, granted by the Purchaser.</li> <li>If delivery is linked to approval of documents, time for submission of such documents to be indicated and delivery period to be indicated from approval of documents. This delivery schedule will be considered for processing delivery extension, wherever applicable.</li> <li>BHEL reserves the right to cancel the order if material is not delivered within PO scheduled delivery.</li> </ul>	
B	In case of foreign supplies, the date of Bill of Lading (B/L) or AWB shall be taken as actual date of delivery.	
C	In case of Indigenous bidders, the date of delivery at named destination in India shall be taken as contractual delivery completion date where delivery terms are FOR destination. In case of 'Ex-works' delivery terms, the date of LR / RR shall be the contractual delivery completion date.	
7	<b>Transit Insurance</b>	



BP 200102

## GENERAL TERMS AND CONDITIONS OF ENQUIRY

A	Except where delivery terms are agreed on CIF basis for Imports & FOR destination basis for indigenous purchases, transit insurance will be covered by BHEL under its Open Marine Transit Insurance Policy. Seller shall inform dispatch particulars with value of consignment to the Purchaser within 07 days of dispatch for BHEL to arrange insurance coverage in its policy. Failure on the part of seller to inform dispatch particulars will make him liable to pay for any transit damages / losses suffered by the Purchaser.
8	<b>Force Majeure</b>
A	Notwithstanding anything contained in the contract, neither the Seller nor the Purchaser shall be held responsible for total or partial non-execution of any of the contractual obligations, should the obligation become unreasonably onerous or impossible due to occurrence of a 'Force Majeure' which directly affects the obligations to be performed by the Purchaser or the Seller; Such events include war, military operations of any nature, blockages, revolutions, insurrections, riots, civil commotions, insurgency, sabotage, acts of public enemy, fires, explosion, epidemics, quarantine restrictions, floods, earthquake, or acts of God, restrictions by Govt. authorities; over which the Seller or the Purchaser has no control. The party claiming to be affected by force majeure shall notify the other party in writing without delay, within two weeks on the intervention and on the cessation of such circumstance. Extension of time sought by the Seller along with supporting evidence and so granted by the Purchaser for the supply/ work affected, if any, shall not be construed as waiver in respect of remaining deliveries. Rescheduling of deliveries on account of force majeure conditions, if so agreed by the Purchaser, will not entail the Seller to claim any increase in the price on whatsoever account. Notwithstanding above provisions, Purchaser shall reserve the right to cancel the order/ Contract, wholly or partly, in order to meet the overall project schedule and make alternative arrangements. If deemed necessary, Purchaser may takeover partly processed material at a mutually agreed price.
9	<b>Penalty for delayed performance.</b>
A	I. Subject to force majeure conditions, penalty shall be 0.5% of the total order value per week of delay or part thereof, subject a maximum of 10% of the total order value. Total order value above shall be item wise, lot wise order value. Any deviation based on specific requirement shall be specified separately in the NIT. II. However, in case of Capital Machine / BOP where staggered deliveries may be applicable, the penalty will be levied on total order value. III. In case of any amendment / revision, the penalty shall be linked to the amended / revised PO. IV. Any loading on penalty clause shall be to the extent to which it is not agreed to by the bidder ( at offered value)
B	If the material is not supplied within the agreed delivery period, BHEL reserves the right to cancel the order and purchase the material from alternate source(s) at the Risk and Cost of the Seller. In such an event, it shall be obligatory on the part of seller to make good any loss suffered by the purchaser.
C	In case the contractually agreed delivery date falls on a holiday in BHEL Bhopal, the next working day shall be taken as contractual delivery date for compliance and applicability of LD / penalty.
10	<b>Indian Agents and Agency commission</b>
A	BHEL prefers to deal directly with Foreign vendor, wherever required, for procurement of Goods. However if the Foreign Principal desires to avail services of an Indian Agent, then the Principal should ensure compliance to "regulatory guidelines" which will require submission of an agency agreement.
B	The CFR / CIF price quoted will be deemed to be inclusive of Indian Agency commission. Agency commission as disclosed by the bidder in his quoted CFR / CIF price will be paid in Indian Rupees on receipt & acceptance of Materials or it's installation at destination, as the case may be. The lower of the 'TT buying rate prevailing on the date of technical bid opening or price bid opening shall be considered for computation of Agency commission.
C	In a tender either the Indian Agent on behalf of Principal / OEM or the Principal / OEM itself can bid, but both cannot bid simultaneously for same item / product in the same Tender. In case bids are received from both the Principal / OEM and the agent, bid received from the agent will be ignored.
D	If an agent submits Bid on behalf of the Principal / OEM, the same agent shall not submit bid on behalf of another Principal / OEM in the Tender, for the same Item / Product.
11	<b>Documentation:</b>
A	<b>Indigenous Purchase</b>
	Seller shall arrange to send to the consignee, Original Tax invoice (Buyer's copy and duplicate for Transporter), Commercial invoice in duplicate, consignee copy of LR & 2 sets each of Packing list, Test certificate, Guarantee / Warranty certificate, O & M manuals (where applicable), immediately on despatch of the goods. The distribution of such documents will be specified in the Purchase order. In case of labour / mixed basis jobs, material is issued free of cost. Necessary material reconciliation is to be done and Free Issue Material Statement (FIMS) is to be submitted with each bill.
B	<b>Foreign Purchase — Imports</b>
	Seller shall send 1 set of following documents, in English, within 7 days of B/L date / 1 day of AWB date by courier to the



BP 200102

**GENERAL TERMS AND CONDITIONS OF ENQUIRY**

	<p>Purchaser</p> <ol style="list-style-type: none"> <li>Express / Original 'Clean on board' Bill of Lading / AWB.</li> <li>One set of Commercial Invoice, Packing list indicating container-wise Gross weight, Net weight, CBM volume, No. of packages with Dimensions of each package.</li> <li>Original Certificate of Country of Origin issued by Chamber of Commerce.</li> <li>One set of Original Test Certificates and O&amp;M Manual where called for.</li> <li>Fumigation / Phyto Sanitary Certificate wherever cargo is packed in wooden packing or packing of plant origin material is used.</li> <li>Supplier should additionally forward 2 sets of original documents mentioned at point 1 to 5 along with original bill to Lading through any international courier service/registered airmail or AWB by captain's mail within three days of obtaining the same directly to the following:             <table border="0" style="width: 100%;"> <tr> <td style="width: 50%; vertical-align: top;">               (i) AGM (M.S)                Regional Operations Division BHEL                14<sup>th</sup> Floor Centre-1                World Trade Centre, Cuffe Parade                Colaba, Mumbai 400 005 INDIA                Email - <a href="mailto:msseabpl@bhel.in">msseabpl@bhel.in</a> (In case of sea freight)  <a href="mailto:msair@bhel.in">msair@bhel.in</a> (In case of air freight)             </td> <td style="width: 50%; vertical-align: top;">               (ii) DGM (FIN- FP)                4<sup>th</sup> Floor, Administrative Bldg.                BHEL Bhopal - 462022 (India)                E-mail : <a href="mailto:fin_fp@bhelbpl.co.in">fin_fp@bhelbpl.co.in</a> </td> </tr> </table> </li> </ol> <p>And confirm forwarding details to AGM (MM- FE), BHEL Bhopal at <a href="mailto:mmfe@bhelbpl.co.in">mmfe@bhelbpl.co.in</a></p> <ol style="list-style-type: none"> <li>In case the Seller decides to negotiate all 3 originals of B/L / AWB along with all original documents through negotiating Bank, non-negotiable documents (NNDs) consisting of copy of B/L / AWB &amp; documents mentioned at Sl. no. 11- B2 to B5 will be sent by e-mail to the Purchaser at his e-mail address given in the PO with one copy to be mailed at <a href="mailto:mmfe@bhelbpl.co.in">mmfe@bhelbpl.co.in</a> &amp; <a href="mailto:msseabpl@bhel.in">msseabpl@bhel.in</a> (for sea shipment) or <a href="mailto:msair@bhel.in">msair@bhel.in</a> (for air shipment). Other documents, as required, will be separately indicated in the Purchase Order. Additional expenditure, if any, incurred by the Purchaser by way of detention / demurrage, resulting out of delay attributable to the Seller in providing Negotiable documents, will be recovered from the Seller.</li> </ol> <p>In case any discrepancy is raised by bankers / BHEL with respect to documents submitted, vendor to facilitate clearance of goods through Delivery Order.</p>	(i) AGM (M.S) Regional Operations Division BHEL 14 <sup>th</sup> Floor Centre-1 World Trade Centre, Cuffe Parade Colaba, Mumbai 400 005 INDIA Email - <a href="mailto:msseabpl@bhel.in">msseabpl@bhel.in</a> (In case of sea freight) <a href="mailto:msair@bhel.in">msair@bhel.in</a> (In case of air freight)	(ii) DGM (FIN- FP) 4 <sup>th</sup> Floor, Administrative Bldg. BHEL Bhopal - 462022 (India) E-mail : <a href="mailto:fin_fp@bhelbpl.co.in">fin_fp@bhelbpl.co.in</a>
(i) AGM (M.S) Regional Operations Division BHEL 14 <sup>th</sup> Floor Centre-1 World Trade Centre, Cuffe Parade Colaba, Mumbai 400 005 INDIA Email - <a href="mailto:msseabpl@bhel.in">msseabpl@bhel.in</a> (In case of sea freight) <a href="mailto:msair@bhel.in">msair@bhel.in</a> (In case of air freight)	(ii) DGM (FIN- FP) 4 <sup>th</sup> Floor, Administrative Bldg. BHEL Bhopal - 462022 (India) E-mail : <a href="mailto:fin_fp@bhelbpl.co.in">fin_fp@bhelbpl.co.in</a>		
<b>C</b>	<b>General</b>		
	<ol style="list-style-type: none"> <li>For Hazardous chemicals, the materials safety data sheet (MSDS) is to be submitted.</li> <li>All certificates as called must be sent. BHEL may test any goods supplied and their decision is final irrespective of supplier's certificates. If test certificate and guarantee certificate are not received along with the document and stipulated in these specifications, BHEL reserves the right to get the material tested and recover the expenses from the supplier without awaiting supplier's confirmation</li> </ol>		
<b>12</b>	<b>Pricing Terms</b>		
<b>A</b>	Prices once quoted shall remain firm within the validity or any extension thereof for placement of order, till complete execution of the order, without any escalation/increase for any reason, whatsoever, unless specifically provided for in the Enquiry & PO. In case of foreign vendors, the quoted price shall be taken as inclusive of Third Party Inspection and testing charges as called for in the NIT.		
<b>13</b>	<b>Price Validity :</b>		
<b>A</b>	Unless stated otherwise in the enquiry, offer shall be valid for a period of 90 days from the date of Techno- commercial (Part-I) bid opening date.		
<b>14</b>	<b>Taxes &amp; Duties - Indigenous Purchase</b>		
	Vendor to ensure timely remittance of SGST, CGST , IGST as applicable in time as per law.		
	Vendor to ensure compliance to filing of monthly GST sales return including BHELs supplies by 10 <sup>th</sup> of next calendar month in the online GST portal wherever applicable.		
	Vendors to declare filing of timely returns and GST remittance/likely remittance /ITC adjustment alongwith invoice.		
	Vendor to submit invoices compliant with GST invoice Rules		
	Vendors to comply with all statutory provisions as may be applicable at the time of despatch/sale. Any additional financial liability to BHEL on account of non-compliance by vendors shall be borne by them and shall be adjusted / recovered from the vendors. BHEL reserves the right to review the existing offers / contracts for any revision in terms, which may arise due to change in any statutory provisions to ensure that the benefit accrues to BHEL.		
	Vendor to ensure TAX INVOICE submission along with consignment		
	In respect of cases where the liability to discharge GST is on BHEL under reverse charge mechanism, vendors have to ensure timely submission of invoices and delivery of material / services to BHEL, so that there is no mismatch on both activities. In case there is any additional financial liability on BHEL on account of default on the part of the vendor on submission or delivery of material / services the same shall be passed on to them.		



BP 200102

## GENERAL TERMS AND CONDITIONS OF ENQUIRY

	In respect of free issue material by BHEL, vendors have to return the processed material within the time line as per the provisions of GST. In case of any additional tax liability on BHEL on account of non-compliance by the vendor, the additional financial implications on BHEL shall be passed on to the vendor
	Vendors to provide the applicable HSN / SAC codes as called for in the enquiry
	As per provisions of section 171 of the CGST Act 2017, bidders to pass on the anti-profiteering benefits accruing to them under GST regime to BHEL
15.	<b>Taxes &amp; Duties - Foreign Purchase — Imports</b>
	The offered prices shall be inclusive of all the Taxes and duties as applicable in the country of bidder / country of dispatch for the quoted CFR / CIF price.
16	<b>Payment Terms-</b>
A	<b>Indigenous:</b> 100% payment in 90 days of receipt (45 days for MSE including NSIC/ Udyog Aadhar registered suppliers as per relevant act in force), subject to acceptance of material at BHEL, on direct presentation of the documents. In case of despatch of material to site directly, site certification for receipt of materials is required unless otherwise provided for in the PO. Any deviation from the above payment terms, if accepted (by BHEL), shall be loaded @ SBI base rate + 6% for the purpose of bid evaluation.
B	<b>Foreign:</b> 100% against irrevocable, unconfirmed LC, payable within 90 days of the Bill of Lading (B/L) date or Payment terms of CAD payable on 90 <sup>th</sup> day of B/L / AWB. In case BHEL considers any deviation in payment terms i.e. early payment based on vendor's request, then bids shall be evaluated with loading of State bank of India Base rate plus 6%, for the credit period short of 90 days. The LC shall be established 2 months prior to shipment date, valid for period of 90 days, unless agreed otherwise.
C	Foreign vendors to submit declaration of <b>Permanent Establishment and Business Connection (PEBC)</b> for remittances purpose. Declaration to be submitted in formats either in Annexure A or B whichever is applicable as per their transaction entered into with BHEL. In the absence of certificates from the vendor, withholding tax at applicable rates along with surcharge and cess will be recovered at the time of remittance to the vendor.
D	Foreign vendors to submit <b>Tax Residency Certificate (TRC) &amp; Form 10F</b> (for obtaining DTAA benefits) as per Annexure C in respect of services. The TRC (tax residency certificate) is to be issued by the authorities of the government of vendor's country. If the informative part of the format (other than residency) is not furnished by the authorities the same may be furnished by the vendor as a declaration.
17	<b>Inspection of Goods</b>
A	The Seller shall give adequate notice, of 1 week or as mutually agreed period, in writing to the Purchaser (in case Customer inspection is involved) or BHEL appointed TPIA about the date and place at which the goods will be ready for inspection/ testing, as provided for in the contract.
B	Purchaser or his authorized representative shall be entitled to carry out inspection of material and workmanship/Surveillance Audit at Seller's premises or at his sub-contractor's premises at all reasonable times during execution of contract; Such inspection, examination and testing, if made, shall not absolve the Seller from his obligations under the contract. Wherever required, BHEL may carry out testing at BHEL's testing Lab and in case of any rejection during such testing, replacement / rectification, as required, will have to be done by Supplier. If BHEL carries out any rectification of such rejected material, such cost will be recovered from Supplier's Bills. In case of Customer inspection as Supplier's Works, inspection clearance to be obtained from Customer and submitted to BHEL.
C	BHEL's representative from unit or Corporate Quality (CQ) is authorised to carry out audits along with TPIA at vendor's works before clearing the items for despatch.
D	All costs related to inspections and re-inspections shall be borne by the Seller. In case of inspection by BHEL and / or BHEL's customer, the cost of to & fro passage and Boarding & Lodging shall be borne by the Purchaser / Customer, unless otherwise specifically agreed. In case of foreign vendors, the cost of third party inspection, where called for, shall be deemed to be included in the quoted price. Seller shall be responsible to provide assistance such as labour, materials, electricity, fuels, stores, apparatus, instruments at his cost, as may be required and as may be reasonably demanded to carry out such tests effectively.
E	<b>REJECTION:</b> If any goods are rejected, BHEL shall be at liberty to take action as per following at the risk and cost of supplier:  a) Allow the supplier, wherever mutually agreed, to rectify the rejected goods at BHEL's works within reasonable time as fixed by BHEL.  Or  b) Allow the supplier to make free replacement within a specified period. Rejected goods can be lifted by the



BP 200102

## GENERAL TERMS AND CONDITIONS OF ENQUIRY

	<p>supplier thereafter.</p> <p style="text-align: center;">Or</p> <p>c) In case payment has been done, allow supplier to refund equivalent value of rejected material by NEFT / RTGS or furnish Bank Guarantee for same amount before lifting the rejected goods. Fresh replacement shall be regulated as per terms and condition of the original Purchase Order. In case payment has not been done, allow the supplier, wherever mutually agreed, to rectify the rejected goods at supplier's works within reasonable time as fixed by BHEL.</p> <p style="text-align: center;">Or</p> <p>d) Take alternate procurement action from elsewhere and recover the difference in total cost to BHEL including services, if any, incurred by BHEL in this regard from the supplier. The supplier shall not be entitled to any gain on repurchase.</p> <p style="text-align: center;">Or</p> <p>e) Terminate the contract either in part or in whole at the discretion of BHEL and recover the loss, if any, from the supplier.</p> <p style="text-align: center;">Or</p> <p>f) Any goods rejected by BHEL must be removed by the supplier after making payment through NEFT / RTGS within 45 days from the date of intimation of rejection or 30 days after receipt of the intimation of rejection whichever is earlier. If vendor fails to lift or allow despatch of rejected material at his cost within 90 days from the intimation of rejection, his claim on rejected material shall cease.</p>
18	<b>Guarantee / Warranty and corresponding Repairs / Replacement of Goods</b>
A	<p>Manufacturer's works test/infection certificates shall be furnished along with the guarantee that material conforms strictly to the specification for general &amp; special conditions as laid down in the purchase order. Goods shall comply with the specifications for material, workmanship and performance. The warranty shall be for a period of 12 months from the date of receipt. If the delivery is found non-compliant during the warranty period, leading to rejection, the Seller shall arrange free replacement / repair of goods, within one month from the date of intimation or any mutually agreed period. The rejected goods shall be taken away by the Seller at his cost and replaced on Delivered Duty Paid (DDP) (FOR - BHEL Stores/ designated destination basis) within such period. In the event of the Seller's failure to comply, Purchaser may take action as appropriate, including Repair / Replenish rejected goods &amp; disposal of rejections, at the risk &amp; cost of the Seller.</p> <p>In case the defects attributable to Seller are detected during processing of the goods at purchaser's / his subcontractor's works, the Seller shall be responsible for free replacement/ repair of the goods as required by the purchaser.</p>
19	<b>Evaluation and Loading Criteria:</b>
	<p>Evaluation of the tender shall be on the basis of delivered cost, i.e. 'total cost to BHEL' w.r.t the technical scope and commercial conditions finalized after techno-commercial clarifications (after considering, inter alia, Customs Duty and GST / Other taxes as applicable). Exchange rate (TT selling rate of State Bank of India) applicable on the date of Part-I bid opening shall be considered for evaluation of foreign bids. If the relevant day happens to be a bank holiday in India, then the FOREX rate as on the previous bank working day shall be taken for evaluation.</p> <p>Foreign suppliers shall ensure that the benefits as applicable under Comprehensive Economic Partnership Agreement (CEPA) with Government of India are disclosed in the bid &amp; relevant documents such as Certificate of Country of Origin, issued by the appropriate authority in the country of Export, is provided by the vendor along with dispatch documents. Bids shall be evaluated with such applicable benefits. In the event of Seller failing to provide appropriate documents for Purchaser to avail disclosed concessional duty benefits in India, financial loss, so incurred, will be to the Seller's account.</p>
20	<b>Variation of orders</b>
	<p>No variation to the Purchase order is permitted unless authorised in writing and signed by or on behalf of purchase executive, BHEL Bhopal.</p>
21	<b>Sub-contract</b>
	<p>BHEL's order or part thereof, if further to be subcontracted in exceptional circumstances the details of subcontracting and to whom to be subcontracted shall be furnished to BHEL and written permission shall be obtained from BHEL. However, it shall not absolve the supplier of the responsibility of fulfilling BHEL order requirements.</p>
22	<b>Recovery / deductions of amount from supplier</b>
	<p>a Any amount on account of recovery from consignor / supplier under any condition shall be liable to be adjusted against any amount payable to the consignor/supplier against bills.</p> <p>b For any deficiency in supplies where deduction is involved, an amount as decided by BHEL, shall be deducted from supplier's bills.</p>
23	<b>Safety clause for purchase orders</b>
	<p>The vendors shall maintain and ensure sufficient safety measures as required for inspections and test like HV test. Pneumatic test, Hydraulic test Spring test, Bend test, Material handling and safe working environment etc. to enable</p>



BP 200102

## GENERAL TERMS AND CONDITIONS OF ENQUIRY

	<p>Inspection Agency for performing inspection. The vendor shall ensure that all the safety precautions specified in factories Act 1948 chapter-IV Section-21 to 41 are complied with respect to equipment's to be inspected. If any test equipment is found not complying with proper safety requirement, then the inspection agency may withhold inspection, till such time the desired safety requirements are met.</p>
24	<b>Non-Disclosure Agreement</b>
	<p>All Drawing and technical documents relating to the product or it's manufacture submitted by one party to the other, prior or subsequent to the formation of contract, shall remain property of the submitting party. Drawing, technical documents or other technical information received by one party, shall not without the consent of the other party, be used for any other purpose than that, for which they were provided. Such technical information shall not without the consent of the submitting party, otherwise be used or copied, reproduced, transmitted or communicated to a third party. Patterns supplied by BHEL will remain BHEL's property which shall be returned by the bidder on demand to BHEL. Bidder shall in no way share or use such intellectual property of BHEL to promote his own business with others. <b><u>BHEL reserves the right to claim damages from the bidder, or take appropriate penal action as deemed fit against the bidder, for any infringement of the provisions contained herein.</u></b></p>
	<p>DRAWINGS, PATTERNS &amp; TOOLS: All drawings, patterns &amp; tools supplied by BHEL or made at BHEL's expense are BHEL's property. These cannot be used or referred to any other party and must only be used in the execution of BHEL's orders. These should be preserved at the supplier's cost for a period of not less than 5 years. Patterns &amp; tools should be returned to BHEL within 90 days of issue of the same.</p>
25	<b>Settlement of Disputes &amp; Arbitration</b>
A	All questions/interpretations regarding subject matter of the Contract shall be decided by the Purchaser on the request of the Seller and the decision of the Purchaser shall be final.
B	In case of dispute, steps shall be taken by the parties to the contract to settle the same through negotiations.
C	In case, dispute is not settled in negotiations, it shall be referred to Conciliator appointed by the competent authority of the Purchaser.
D	<p>Except as provided elsewhere in this Contract, in case amicable settlement is not reached between the Parties, in respect of any dispute or difference; arising out of the formation, breach, termination, validity or execution of the Contract; or, the respective rights and liabilities of the Parties; or in relation to interpretation of any provision of the Contract; or, in any manner touching upon the Contract, then, either Party may, by a notice in writing to the other party refer such dispute or difference to the sole arbitration of an arbitrator appointed by Head of the BHEL Unit/Region/Division issuing the Contract.</p> <p>The Arbitrator shall pass a reasoned award and the award of the Arbitrator shall be final and binding upon the Parties. Subject as aforesaid, the provisions of Arbitration and Conciliation Act 1996 (India) or Statutory modifications or re-enactments thereof and the rules made thereunder and for the time being in force shall apply to the arbitration proceedings under this clause. The seat of arbitration shall be Bhopal.</p> <p>The cost of arbitration shall be borne as per award of the Arbitrator.</p> <p>Subject to the arbitration in terms of Clause above, the Courts at Bhopal shall have exclusive jurisdiction over any matter arising out of or in connection with this Contract.</p> <p>Notwithstanding the existence or any dispute or differences and /or reference for the arbitration, the Contractor shall proceed with and continue without hindrance the performance of its obligations under this Contract with due diligence and expedition in a professional manner except where the Contract has been terminated by either Party in terms of this Contract.</p> <p><b>In case of Contract with Public Sector Enterprise (PSE) or Government Department, the following shall be applicable :</b> In the event of any dispute or difference relating to the interpretation and application of the provisions of the Contract, such dispute or difference shall be referred by either Party for arbitration to the sole arbitrator in the Department of Public Enterprises to be nominated by the Secretary to the Government of India in-charge of the Department of Public Enterprises. The Arbitration and Conciliation Act, 1996 shall not be applicable to arbitration under this clause. The award of the arbitrator shall be binding upon the Parties to the dispute, provided, however, any Party aggrieved by such award may make further reference for setting aside or revision of the award to the Law Secretary, Department of Legal Affairs, Ministry of Law and Justice, Government of India. Upon such reference the dispute shall be decided by the Law Secretary or the Special Secretary or Additional Secretary when so authorized by Law Secretary, whose decision shall bind the Parties hereto finally and conclusively. The Parties to the dispute will share equally the cost of arbitration as intimated by the Arbitrator.</p>
E	The Seller shall continue to perform the contract, pending settlement of dispute(s).
26	<b>Applicable Laws and Jurisdiction of Courts</b>
	<p>Indian laws both substantive and procedural, for the time being in force, including modifications thereto, shall govern the Contract including Arbitration proceedings. The competent Courts at Bhopal in the State of Madhya Pradesh, India</p>



BP 200102

**GENERAL TERMS AND CONDITIONS OF ENQUIRY**

	shall have sole jurisdiction.
27	<b>RIGHT OF REJECTION /NON- PLACEMENT OF PO:</b> BHEL reserves the right to accept the offers in part or in full, or cancel the Tender enquiry without assigning any reason.
28	<b>Performance Bank Guarantee (PBG)/ Security Deposit (SD):</b>
A	Wherever PBG (covering equipment / system / work performance guarantee) is called for in the Notice Inviting Tender (NIT) deviation shall not be accepted.
B	Bank Guarantee wherever called for, shall be in the BHEL prescribed format. In case the order is to be placed in foreign currency, the BG must also be in Foreign currency, so specified by the Purchaser.
C	Wherever Security Deposit (covering contract performance) is called for in the NIT, deviation shall not be accepted.
D	Composite 'Contract Performance Bank Guarantee' of matching value/ validity, where both Security Deposit and Performance Bank Guarantee are required, shall not be construed as deviation.
E	Wherever the contract is for supply of Goods processed on labour basis from BHEL supplied materials, the materials shall be issued against a suitable Bank guarantee as specified in the Enquiry.
29	<b>Benefits earmarked for Purchase from Micro &amp; Small Enterprises (MSEs) — Indigenous Purchase</b>
A	Tender documents shall be issued free of cost & no EMD wherever called for will be insisted upon. MSE bidders shall submit along with bid relevant documents w.r.t. their respective MSE status as per extant norms. Date to be reckoned for determining the deemed validity will be the last date of Technical bid submission. Non- submission of such document will lead to consideration of their bid, at par with other bidders and MSE status of such bidders shall be shifted to Non- MSE supplier till the supplier submit these documents.
B	In tender, participating MSEs quoting price within price band of L1+15% shall also be allowed to supply a portion of requirement by bringing down their price to L1 price in a situation where L1 price is from someone other than a MSE and such MSE shall be allowed to supply up to 20% of total tendered value. In case of more than one such MSE, the supply shall be shared proportionately. A quantum of 4% out of 20% quantity, so earmarked, will be reserved for MSE's owned by SC / ST entrepreneurs who submit their bid with relevant documents provided that in event of failure of such MSE(s) to participate in tender process or meet tender requirements and L1 price, 4% sub-target for procurement earmarked for MSE(s) owned by SC or ST entrepreneurs shall be met from other MSE(s). In case of indivisible tender the full quantity shall be awarded to L1.
C	If an enterprise falling under MSE category as defined in the MSMED Act 2006, graduates to a higher category from its original category or beyond the purview of the Act, it shall continue to avail all non-tax benefits of its original category notified by the Ministry of Micro, Small and Medium Enterprise for a period of three years from the date of such graduation to the higher category.
D	MSE suppliers can avail the intended benefits only if they submit along with the offer, attested copies of either EM II certificate having deemed validity (five years from the date of issue of acknowledgement in EM II) or valid NSIC certificate or EM II certificate along with attested copy of a CA certificate (As per BHEL Format, where deemed validity of EM II certificate of five years has expired) applicable for the relevant financial year (latest audited). Date to be reckoned for determining the deemed validity will be the date of bid opening (Part 1 in case of two part bid). Non submission of such documents will lead to consideration of their bid at par with other bidders. No benefits shall be applicable for this enquiry if any deficiency in the above required documents are not submitted before price bid opening. If the tender is to be submitted through e-procurement portal, then the above required documents are to be uploaded on the portal. Documents should be notarized or attested by a Gazetted officer
30	<b>Integrity Pact (IP) — Independent external monitors (IEM)</b> For tenders in which integrity pact is applicable, following points stand valid :
A	IP is a tool to ensure that activities and transactions between the company and its bidders/contractors are handled in a fair, transparent and corruption free manner. A panel of Independent External Monitors (IEMs) have been appointed to oversee implementation of IP in BHEL. The IP as enclosed with the tender is to be submitted (duly signed by authorized signatory who signs in the offer) along with techno commercial bid. Only those bidders who have entered into such an IP with BHEL would be competent to participate in the bidding. In other words, entering into this pact would be a preliminary qualification. Name : ----- Address : ----- E-mail : ----- } As indicated in NIT / enquiry



BP 200102

## GENERAL TERMS AND CONDITIONS OF ENQUIRY

B	<p>Please refer section 8 of the IP for roles and responsibilities of IEMs. In case of any complaint arising out of tendering process, the matter may be referred to the IEM mentioned in the tender.</p> <p><b>NOTE :</b> No routine correspondence shall be addressed to the IEM (phone / post/e-mail) regarding the clarifications, time extensions or any other administrative queries, etc. on the tender issued. All such clarifications/ issues shall be addressed directly to the tender issuing (procurement) department.</p> <p><b>For all clarifications/ issues related to the tender, Please contact:</b></p> <table border="1" data-bbox="323 479 1374 748"> <thead> <tr> <th></th> <th>( 1 )</th> <th>( 2 )</th> </tr> </thead> <tbody> <tr> <td><b>Name</b></td> <td></td> <td></td> </tr> <tr> <td><b>Landline No.</b></td> <td></td> <td></td> </tr> <tr> <td><b>Mobile No.</b></td> <td></td> <td></td> </tr> <tr> <td><b>Email</b></td> <td></td> <td></td> </tr> <tr> <td><b>Deptt</b></td> <td></td> <td></td> </tr> <tr> <td><b>Address</b></td> <td></td> <td></td> </tr> <tr> <td><b>Fax</b></td> <td></td> <td></td> </tr> </tbody> </table>		( 1 )	( 2 )	<b>Name</b>			<b>Landline No.</b>			<b>Mobile No.</b>			<b>Email</b>			<b>Deptt</b>			<b>Address</b>			<b>Fax</b>		
	( 1 )	( 2 )																							
<b>Name</b>																									
<b>Landline No.</b>																									
<b>Mobile No.</b>																									
<b>Email</b>																									
<b>Deptt</b>																									
<b>Address</b>																									
<b>Fax</b>																									
31	<p><b>Fraud Prevention Policy :</b> The Bidder along with its associate/ collaborators/ sub-contractors/ sub-vendors/ consultants/ service providers shall strictly adhere to BHEL Fraud Prevention Policy displayed on BHEL website <a href="http://www.bhel.com">www.bhel.com</a> and shall immediately bring to the notice of BHEL Management about any fraud or suspected fraud as soon as it comes to their notice.</p>																								
32	<p><b>Integrity Commitment:</b> The offers of the bidders who are under suspension as also the offers of the bidders, who engage the services of the banned firms, shall be rejected. The list of banned firms is available on BHEL website <a href="http://www.bhel.com">www.bhel.com</a>. Integrity commitment, performance of the contract and punitive action thereof :</p>																								
A	<p><b>Commitment by BHEL :</b> BHEL commits to take all measures necessary to prevent corruption in connection with the tender process and execution of the contract. BHEL will during the tender process treat all bidder(s) in a transparent and fair manner, and with equity.</p>																								
B	<p><b>Commitment by bidder / Supplier / Contractor :</b></p> <ul style="list-style-type: none"> <li>- The bidder / supplier / contractor commit to take all measures to prevent corruption and will not directly or indirectly influence any decision or benefit which he is not legally entitled to nor will act or omit in any manner which tantamount to an offence punishable under any provision of the Indian Penal code, 1860 or any other law in force in India.</li> <li>- The bidder / supplier / contractor will, when presenting his bid, disclose any and all payments he has made, and is committed to or intends to make to agents, brokers or any other intermediaries in connection with the award of the contract and shall adhere to relevant guidelines issued from time to time by govt. of India / BHEL</li> <li>- The bidder / supplier / contractor will perform / execute the contract as per the contract terms &amp; conditions and will not default without any reasonable cause, which causes loss of business / money / reputation to BHEL.</li> </ul>																								
C	<p>If any bidder / supplier / contractor during pre-tendering / tendering / post tendering / award / execution / post-execution stage indulges in mal-practices, cheating, bribery, fraud or / and other misconduct or formation of cartel so as to influence the bidding process or influence the price or acts or omits in any manner which tantamount to an offence punishable under any provision of the Indian Penal Code, 1860 or any other law in force in India, then action may be taken against such bidder / supplier / contractor as per the extant guidelines of the company available on <a href="http://www.bhel.com">www.bhel.com</a> and / or under applicable legal provisions.</p>																								

**BHARAT HEAVY ELECTRICALS LIMITED**  
**BHOPAL (INDIA) - 462022**  
**MATERIAL MANAGEMENT DEPARTMENT**  
**GENERAL TERMS & CONDITIONS FOR OVERSEAS PURCHASE ORDER**

shipment has been arranged in accordance with instructions of the Ministry of Shipping & Transport, NEW DELHI.)

The BHEL Purchases Order subject to the following terms & conditions unless otherwise specified and directed.

**1. DOCUMENTATION :**

**1.1 NON-NEGOTIABLE SET :**

Comprising following

- (i) Copy of non negotiable Bill of lading / AWB or HAWB with a mention of AWB No.
- (ii) 2 copies of Signed Commercial Invoice
- (iii) 2 copies of advice Note/detailed packing list in English covering each item and quantity
- (iv) Certificate of Origin
- (v) Inspection/Material Certificate
- (vi) Catalogue/drg. for components (including casting & forging) and for finished Goods

OR

Composition certificate for ferrous/non-ferrous metals/insulating & other raw material, casting & forging and other metallic components.

**1.1.1 DOCUMENTATION CLAUSE :**

\*Advance set of documents are to be forwarded to the following within three days of obtaining Bill of Lading/AWB through any international courier service so as to reach us within 10 days from the date of despatch of material. Failure to do so will make the supplier responsible for making good any loss. Please note that the insurance by BHEL does not absolve the supplier from the responsibility of defective/bad packing, short/wrong supply. Details like BL/AWB with date PO No. and value should be furnished by TLX/FAX/E-MAIL to the concerned Purchase officer of BHEL and to our underwriters.

- (i) **Sr. Manager (M.S.) ROD,** Bharat Heavy Electricals Ltd. World Trader Centre, Centre 1, 14th/15th Floor Cuffe Parade, COLABA, Mumbai 400 005, INDIA Tel: 2180740 FAX : 0091-22-2187850
- (ii) **Branch Manager,** M/s. National Insurance Co. Ltd. First Floor, B-8, Indrapuri, Bhopal (INDIA) Pin - 462021 Tel: 0705-335-NICL-IN, CABLE : NIC DIV.-BHOPAL
- (iii) **Dy. General Manager (CRX)** BHEL, BHOPAL (INDIA) PIN-462022 Tel: 0705-7264, 7265 FAX : 0755-201823, 500946
- (iv) **Dy. General Manager (MM)** Administrative Building, BHEL, BHOPAL (INDIA) PIN : 462022 TELEX : 0705-7264, 7265 FAX : 0755-500023 (Two sets)

**1.1.2 Fax/E-Mail confirmation** indicating full details of shipment i.e., P.O.No., Vessel Name/Flight No. BL/AWB details, Material, Quantity and consignment value to be sent to other agencies as well at point 1.1.1. above, immediately after shipment/air freight.

**1.2 NEGOTIABLE SET :**

- (i) Supplier should additionally forward documents mentioned at point 1.1 (i) to (vi) alongwith original Bill to Lading through any international courier service/registered airmail or AVWB by captain's mail within three days of obtaining the same, directly to the following :

- (i) **Sr. Manager (MS)** Regional Operation Division BHEL, 14th/15th Floors Centre 1, World Trader Centre, Cuffe Parade, Colaba, Mumbai - 400 005 INDIA Fax : 0051-22-2187850 and confirm forwarding details to Sr. manager (MM) FE, BHEL, Bhopal : 462 022 (INDIA)
- (ii) **Manager (FIN) FP** Administrative Bldg. BHEL BHOPAL, 462022 INDIA Tel: 0705-7264, 7265 Fax : 0755-540425 & 201544

**1.3 INSTRUCTIONS FOR DOCUMENTS :**

- (i) Clean Bill of Lading/Copy of AWB in triplicate to be drawn as below :  
Shipper : Govt of India  
Consignee : BHEL, BHOPAL  
**Note : Bank not to be notified as consignee or joint Consignee.**
- (ii) B/L to be drawn on FOB basis as and freight to pay unless otherwise specified in P.O.
- (iii) In case of HAWB a mention should be made of AWB No. always.
- (iv) Signed Invoice should indicate quantity and value of all items supplied. If item is supplied in sets, the quantity and value of pieces making each set should be indicated. For supply of spares (including spares supplied with main equipment) sale value breakup should be indicated item wise. Split up value is a must together with consolidated value. Also item being supplied should be linked up with purchase order serial No. \*Short shipments, if any, should be indicated clearly with quantity and value in the invoice. At the time of subsequent shipment of short shipped items, reference of original invoice should be indicated.\*

- (v) In case of **Free supply** : It should be indicated if supply is against short shipment or replacement together with earlier shipment details & forward documents as per 1.1 & 1.2 above, invoice should indicate value of material for customs purpose.
- (iv) Packing list should include package-wise details and each item clearly identified with the respective packing list.
- (vii) Any Demurrage/Wharfage paid at the ports because of delay/discrepancy in the above documents will be to the account of supplier or their representative.
- (viii) For correspondence & documentation, language must be ENGLISH or HINDI.
- (ix) **DRG. & Patterns** : All Drgs. and Patterns supplied/paid for by BHEL will remain BHEL property and shall be returned to BHEL as and when demanded by BHEL.

**2. CASE MARKING :**

Following details should be clearly marked on each case :

- (i) Shipper : Govt. of India.
- (ii) Consignee : BHEL (BHOPAL) Via MUMBAI (INDIA)
- (iii) BHELORDERNO. \_\_\_\_\_
- (iv) Port of Entry \_\_\_\_\_
- (v) Port of Destination \_\_\_\_\_
- (vi) Gross Weight \_\_\_\_\_ Kgs.
- (vii) Nett Weight \_\_\_\_\_ Kgs.
- (viii) Brief Description : \_\_\_\_\_
- (ix) Dimension in MM : \_\_\_\_\_
- (x) Supplier : \_\_\_\_\_

**3. PACKING :**

Material should be packed suitably in all for normal transport by SEA/Air (as case may be) to India and subsequently by Rail/Road to destination point in India. It should be suitably protected against the effects of tropical salt laden climate. Timber in packing should be free from bark, insects and fungi. Special packing should be provided wherever required in addition to above. Damage to the consignment of account of poor/inferior packing shall be to the account of supplier or their representative.

**3.1 INSTRUCTION FOR PACKING :**

- (i) A broad red band about 100mm (4") wide all round the case just below top for easy identification of BHEL package at the docks, should be painted.
- (ii) All marking for safety, handling, storage and protection etc. are to be clearly marked on the cases as per international practice.
- (iii) A special care should be taken in packing of hazardous material with all precaution for safety.
- (iv) Proper care should be taken to ensure correct case marking and packing should be in accordance with the details in Advice Note/Packing list. Any delay in clearance because of wrong case marking will be to the account of supplier or their representative. Similarly, if for any reason whatsoever discrepancies are noticed prejudicing our claim with underwriters/carriers with consequential loss will also be to the account of supplier or their representative.

**4. MODE OF DESPTACH :**

By Sea / Air as recified in purchase order.

**4.1 BYSEA :**

Following conditions will apply in case of shipments from different countries.

- (a) **FROM JAPAN** : Shipping arrangements will be made by Secretary, Shipping Co-ordination Committee, Ministry of Shipping & Transport, New Delhi (India) Cable: TRANSCART NEW DELHI. Fax No. 011-3718614, 3352726, Through First Secretary (Commercial) Embassy of India, Tokyo, Japan.
- (b) **FROM USA/Canada/Mexico/South America**, Shipment to be arranged per IPBC conference vessel through M/S OPT OVERSEAS PROJECT TRANSPORT, INC. (A THYSSEN HANIEL LOGISTIC CO.) 46 SELLERS STREET, KEARNY, N.J. 07032, TEL: (201) 998-7771, Tlx : 673-3586, fax : (201) 998-7833.
- (c) **FORM OTHER THAN USA/CANADA/MEXICO/SOUTH AMERICA & JAPAN** : Shipment to be arranged per IPBC vessel through M/s. Schenker & International, Deutschland Gmbh, Beiden Muhren 520457, Hamburg Germany, Fax : 0049-4036135509, their agent in UK ara M/s. Schenker Ltd., Royal London House, 13 Finsbury Square, London E2 OR obtain a certificate from them to the effect that

**4.1.1 INSTRUCTIONS FOR DESPATCH :**

- (i) Despatch per Post Parcel is strictly prohibited.
- (ii) Four weeks' notice to be given to shipping Agents about readiness of cargo to finalising the shipping arrangements. Bank not to be notified as-Consignee or Joint Consignee.
- (iii) Material to be shipped free on board (FOB). Inland freight, packing forwarding etc. to be borne by Supplier other than USA Suppliers who will ship the material on FAS basis.
- (iv) Material will be shipped as break bulk FCL cargo. Specific advice of BHEL, Bhopal shall be necessary for shipping on FCL cargo basis.

**4.2 BY AIR :**

Material to be airfreighted through our authorised agents/air consolidators as indicated in the Purchase Order/Letter of Credit. In countries where no authorised agent/consolidators exists, supplier himself will arrange shipment through AIR INDIA flight. Refer Documentation Clause for other details.

**5. INSURANCE :**

Material insurance will be arranged by us at our cost against open Marine Cover obtained from M/s. National Insurance Co. Ltd., Bhopal (India) and advance set of documents should be airmailed directly to them (See Clause 1.1.1)

**6. GUARANTEE & TEST CERTIFICATE :**

Manufacturer's works test/inspection certificates shall be furnished alongwith the guarantee that material conforms strictly to the specification for general & special conditions as laid down in the purchase order

**7. PENALTY :**

Failure to despatch in time as per the terms of delivery mentioned in our order would be liable for supplier, unconditional penalty of 1/2% (half percent) of the price of the goods offered in arrears per week at the discretion of BHEL subject to a maximum of 10% value of the order.

**8. DEFICIENCIES & DEFECTIVE GOODS :**

Should any deficiency or defect be noticed in the goods same shall be replaced by the supplier without any extra charge under NO CHARGE INVOICE. Any complaint in regard to the material will be notified to the supplier who will replace same promptly. The rejected material will have to be accepted back by the supplier who will bear its return freight also & the supplier will reimburse to BHEL the customs duty paid\*\* on defective supply and/or unnotified short shipments.\*

**9. PAYMENT :**

Generally through Irrevocable letter of credit as per detailed terms and conditions mentioned therein to be established by BHEL.

**10. AGENCY COMMISSION :**

Agency Commission, if any, will be paid out of the FOB value after receipt and acceptance of material on inspection, in Indian Rupees on submission of invoice. Exchange rate considered for calculation will be the rate prevailing on the tender opening date or the letter of intent date or date of purchase order, whichever is the lowest.

**11. LAWS :**

The contract shall be governed by the laws of India

**12. ARBITRATION :**

All cases of dispute arising out of or relating to this purchase order shall be referred to the sole arbitration of the Executive Director/General Manager/Incharge, General Manager of BHEL, Bhopal or any other person (including an employee of BHEL, even though he had to deal with the matters relating to this Purchase order in any Manner) nominated by the said Executive Director/General Manager (I)/General Manager to act as sole Arbitrator. The arbitration shall be under the Indian arbitration act, 1940 and rules made there under. The arbitrator may from time to time with consent of parties enlarge the time for making and publishing the award. Seat of arbitration shall be Bhopal.

**13. JURISDICTION :**

All suits or any matters arising out of this purchase order shall lie in Bhopal Courts only.

**14.**

In line with factories Act, section 41-B and Environment Act schedule 9, Rule 17, and as per the requirement of ISO-14001, please submit the material safety Data sheet (MSDS) of hazardous chemicals being imported. This is required to be kept ready by us for producing as and when asked for by regulating inspecting Government Authorities.



FORM NO. MM 6527

Rev - 03

### B.H.E.L., P.O. TERMS & CONDITIONS (INDIGENOUS)

The purchase order is subject to the following terms & conditions unless otherwise specified and directed :-

**1. ORDER ACKNOWLEDGEMENT :**

Order acknowledgement in the enclosed format must reach the concerned officer of Materials Management Divisions within 4 weeks of issue of purchase order. Failure to do so within stipulated period will be deemed to mean that the order has been accepted by the supplier.

**2. PACKING :**

a) The supplier shall securely protect and pack the goods against loss, damage or corrosion in transit. Packing shall allow for easy removal and checking on site and comply with carrier conditions of packing or established trade practice.

b) Cases and packing materials shall be supplied free of charge unless otherwise agreed to. Wherever specifically agreed to, empties shall be returned at suppliers expense but no liability will be accepted by BHEL in respect thereof.

c) Damage to the consignment resulting out of poor/inferior packing shall be to the account of the supplier.

**3. MARKING :**

The following details to be clearly marked on each case/box/packing/bundle and reel.

i) Consignee ii) BHEL Order No. iii) Gross weight iv) Net weight v) Dimensions in CMS vi) Brief description of item vii) BHEL Destination Code (refer purchase order) viii) Consignor.

b) All markings for safety, proper handling, storage, protection etc. are to be clearly marked on the case as per Indian Standard.

**4. CONSIGNEE :**

Unless otherwise mentioned, all goods shall be consigned as noted below :

a) Rail : Sr. Manager, Central Receiving Section, HESG Central Railway via Bhopal.

Note : Goods must not be consigned to Bhopal Station, HESG via Bhopal as in assigned siding in IRCA Chapter VIII page 373. All goods in small or wagon loads should be booked to this siding.

b) Road : Sr. Manager, Central Receiving Section Block VII, BHEL, Bhopal - 462 022. BHEL Despatches must be arranged through BHEL's approved transporters on door delivery basis.

c) Post/Air parcel : Sr. Manager Central Receiving section Block VII, BHEL, Bhopal - 462 022.

d) Supplier not complying with instructions at (a), (b) & (c) above shall do so at their risk and cost.

**5. PRICE :**

Unless specifically agreed to other wise, all prices shall be treated as FIRM.

**6. TERMS OF PAYMENT :**

The standard payment terms shall be as specified below and specified in the Purchase Order. It is however made clear that BHEL shall not accept any interest liability.

**A. Local ancillary and SSI Units and other local parties.**

100% payment on receipt and acceptance of Materials within 90 days of the date of receipt in BHEL.

**B. Outstation SSI and other Suppliers.**

BHEL prefers 'door delivery' of material in which case payment shall be within 90 days from the date of despatch. In case documents through Bank 100% payments within 90 days from the date of despatch of Material. Delivery at our works.

In case of Payments through other negotiable instrument like Bill of Exchange/Hundies etc. then the Material be delivered on 'door delivery' basis. 100% payment within 90 days from date of acceptance of negotiable Bill, or Exchange/Hundies. Hundies will be accepted by BHEL within 7 days of presentation or otherwise in accordance with contract.

नोट - भुगतान के रूप में बिल/हण्डियों का प्रयोग किया जा सकता है। बिल/हण्डियों का प्रयोग करने से पहले इनके अंगीकार/गोपनीयता का प्रावधान होना चाहिए। यदि भुगतान के लिए कोई भी बिल/हण्डियां प्रस्तुत की जाती हैं तो वे 90 दिनों के भीतर अंगीकार/गोपनीयता के लिए प्रस्तुत की जाननी चाहिए।

NOTE :- The cheque will be sent by Registered post and the Company will in no way be responsible, if loss occurs due to delay by postal authorities or cheque falling into improper hands through forgery of fraud.

**7. DOCUMENTATION :**

The supplier shall forward four sets of the document as detailed below :-

a) 1 set to the concerned Purchase officer, Materials management Deptt. 2nd floor Administrative Building, BHEL Bhopal-462 022, Comprising of

- i) Invoice 1 copy
- ii) Challan/Despatch Advice note 2 copies
- iii) Guarantee Certificate 3 copies
- iv) Test Certificate 4 copies
- v) Proforma for insurance 2 copies
- vi) Photo copy of ED Paying Document 1 copy
- vii) Photo copy of LR/RR 1 copy

b) 1 set to Dy. General Manager, Central Receiving Section, Block-VII, BHEL, Bhopal-462 022 comprising of :-

- i) Original LR/RR (if not negotiated through Bank)
- ii) Invoice 1 copy
- iii) Challan/Despatch advice note 1 copy
- iv) Excise Duty Paying document (Excise challan)

c) 1 set to Dy. Manager Purchase Bills Section, 4th floor Administrative Building BHEL, Bhopal-462022 comprising of :-

- i) Signed invoice 2 copies
- ii) Excise Duty Paying Document (duplicate/photo copy) 1 copy

d) 1 set to the bank in case of documents negotiated through Bank separately to each Purchase order comprising of :-

- i) Original RR/LR
- ii) Signed Invoice 2 copies
- iii) Original Excise duty Paying Document (only in case of rail despatches)
- iv) Test Certificate 1 copy
- v) Guarantee certificate 1 copy

**Note :**

'C' form shall be issued directly to the supplier. No 'C' form shall be exchanged against documents through Bank. This will be issued once in a year against a P.O. In case of materials going to site directly, 'C' form will be issued after suppliers confirmation that he will issue corresponding E1 form.

**8. Excise only :** The original Excise duty paying document or equivalent document indicating tariff Item No. and drawn in favour of BHEL, Bhopal for each consignment shall accompany the transporters in case of road despatches and with R/R in case of rail despatches. In case of any other mode of despatch (such as Regd. Post Parcel /Air Parcel etc.) the same shall be forwarded to Sr. Manager, Central Receiving Section, Block VII, BHEL, Bhopal-462 022 directly by registered post/hand delivery. The Excise duty paying document must not be enclosed inside the packing case. No Excise Duty shall be paid in the absence of the above document.

**9. SALES TAX :**

BHEL Bhopal is registered as a manufacturer under Sales Tax registration No. BPL/HEL/11, MPST No. BPL/HLS, Sales Tax declaration form will be issued as per rules. Supplier is to furnish E-1 form within 15 days after receipt of 'C' form in favour of Sr. Mgr. (Sales Tax) Materials Management Deptt. for the despatches direct to customers i.e. Destination other than BHEL Bhopal Otherwise full CST & Penalty will be paid by Supplier.

**10. INSURANCE :**

supply. Wherever possible despatch particulars like MR with date, PO No. and value should be furnished. TLX. TLG to Sr. Mgr. concerned group and to our underwriters (Gram : National Insurance TLX : cable/NIC Div.

**11. QUALITY :**

All the goods supplied and services rendered must be the best of their kind and conform to the spe mentioned in the order and/ or to be strictly in accordance with approved samples or drawings.

**12. INSPECTION :**

All the goods and works are subject to BHEL's inspection or where stipulated by BHEL's client or his nominees at supplier works. Despatch can be arranged against despatch clearance note issued inspection and/or customer's representative, However final acceptance is subject to inspection and ac at the destination.

**13. TEST CERTIFICATE :**

All certificates called for in the specification or order must be sent by Registered Post with the Adh BHEL may test any goods supplied and their decision is final irrespective of supplier's certificates.

If test certificate and guarantee certificate are not received alongwith the document and stipulated specifications, BHEL reserves the right to get the material tested and recover the expenses from th without awaiting suppliers confirmation.

**14. GUARANTEE :**

All goods shall be free from any defect due to faulty design/material and / or workmanship/erection called for) and will be guaranteed for a period of twelve months from the date of commissioning of the 24 months from the date of despatch whichever is earlier. However, for any "Type defects" Suppl responsible even after 24 months, if failure of the item on a/c of this.

Where the contract stipulates submission of Bank guarantee the Suppliers shall get validity period of extended from the Bank as and when required, failing which it will be treated as Breach of the ten contract and the contract is liable to be cancelled and the loss suffered by BHEL shall be recoverable supplier.

**15. REJECTION :**

If any goods are rejected, BHEL shall be at liberty to take action as per following at the risk and cost a) Allow the supplier, where ever mutually agreed, to rectify the rejected goods at BHEL's work within n time as fixed by BHEL.

b) Allow the supplier to make free replacement within a specified period. Rejected goods can be lift supplier thereafter.

c) Allow supplier to refund the full amount paid to him by BHEL by a demand draft before lifting the reject Fresh replacement shall be regulated as per terms and condition of the original Purchase Order.

d) Take alternate procurement action from elsewhere and recover the difference in cost. If any, incurred in this regard from the supplier. The supplier shall not be entitled to any gain on repurchase.

e) Terminate the contract either in part or in whole at the discretion of BHEL and recover the loss if any supplier.

f) Any goods rejected by BHEL must be removed by the supplier after making payment through Dem within 45 days from the date of intimation of rejection or 30 days after receipt to of the intimation of which ever is earlier. If the goods are not removed within the period stipulated above, the goods shall be sold by BHEL and the proceeds there of shall be adjusted towards storage charge and or the

**16. DRAWINGS, PATTERNS & TOOLS :**

All drawings as also all patterns and tool supplied by BHEL or made at BHEL's expense are BHEL's These cannot be used or referred to any other party and must only be used in the execution of BHEL These should be preserved at the supplier's cost for a period of not less than 5 year.

**17. INDEMNITY :**

Supplier shall indemnify BHEL against the following:

a) Any claim or infringement of letters, patent or registered design by the use or sale of any article or supplied to BHEL and against all costs and damages which may incur in any action for such infrinng which BHEL become liable in any such action.

b) All claims for injury or damages caused by the suppliers negligence or the negligence of supplier's or arising from any defect in the goods supplied or on the work carried out the supplier.

c) All claims for injury to the supplier's employees or agents employees whilst on BHEL premises.

**18. SUB-CONTRACT :**

BHEL's order or part there off, if further to be subcontracted in exceptional circumstances the subcontracting and to whom to be subcontracted shall be furnished to BHEL and written permission obtained from BHEL. However it shall not absolve the supplier of the responsibility of fulfilling Bt requirements.

**19. VARIATION OF ORDERS :**

No variation to this order is permitted unless authorised in writing and signed by or on behalf of executive. BHEL Bhopal.

**20. LIQUIDATION DAMAGE/PENALTY :**

a) Failure to effect supply by the time specified in the order or period of extension granted in writing by make the supplier liable to pay liquidated damage/an unconditional penalty, as the case may be, of Percent) of the price of the goods in arrears per week at the discretion of BHEL, subject to a maximum of the order value.

b) If the material is not supplied within stipulated time BHEL shall be within their right to cancel the co purchase, the material through any other source at the risk and cost of the supplier, in such an event obligatory on the defaulting supplier to make good any loss suffered by BHEL.

**21. ADJUSTMENT OF RECOVERY OF AMOUNT PAYABLE BY THE SUPPLIER :**

Any amount payable by the consignor/supplier under any of the condition of this contract shall be li adjusted against any amount payable to the consignor/supplier under any other works/contract a him. This is without prejudice to any other action as may be deemed fit by BHEL.

**22. JURISDICTION :**

All suits or any matters arising out of this purchase order shall be lie in BHOPAL COURTS ONLY.

**23. ARBITRATION :**

In all cases of disputes emanating from and in reference to this Purchase Order the matter shall be the arbitration of the sole arbitration of the Executive Director/ GM of BHEL, Bhopal or any oth (including an employee of BHEL, even though he had to deal with the matter relating to this P.O. in an nominated by the said Executive Director/ GM to act as sole arbitrator. The arbitration shall be u ARBITRATION AND CONCILIATION ACT OF 1996 and the rules there under. The arbitrator may fro time with the consent of the parties enlarge the time for making and publishing the award.

**24. HAZARDOUS/TOXIC CHEMICALS :**

Supplier to supply the "Material Safety Data Sheet (MSDS)" in the standard prescribed proforma i environment act Schedule-9 Rule 17, Manufacture, Storage And IMPORT of chemicals Rule-1989.

**25. SAFETY CLAUSE FOR PURCHASE ORDERS :**

The vendors shall maintain and ensure sufficient safety measures as required for inspections and to test, Pneumatic test, Hydraulic test, Spring test, Bend test, Material handling and safe working en etc. to enable Inspection Agency for performing inspection.

The vendor shall ensure that all the safety precautions specified in factories Act 1948 Chapter-IV : to 41 are complied with respect to equipments to be inspected.

If any test equipment is found not complying with proper safety requirements, then the inspection a