

ALL DIMENSIONS ARE IN MILLIMETRES. FOR TOLERANCES OF UNTOLERANCED DIMENSIONS DURING MANUFACTURE REFER RELEVANT QCP / QP

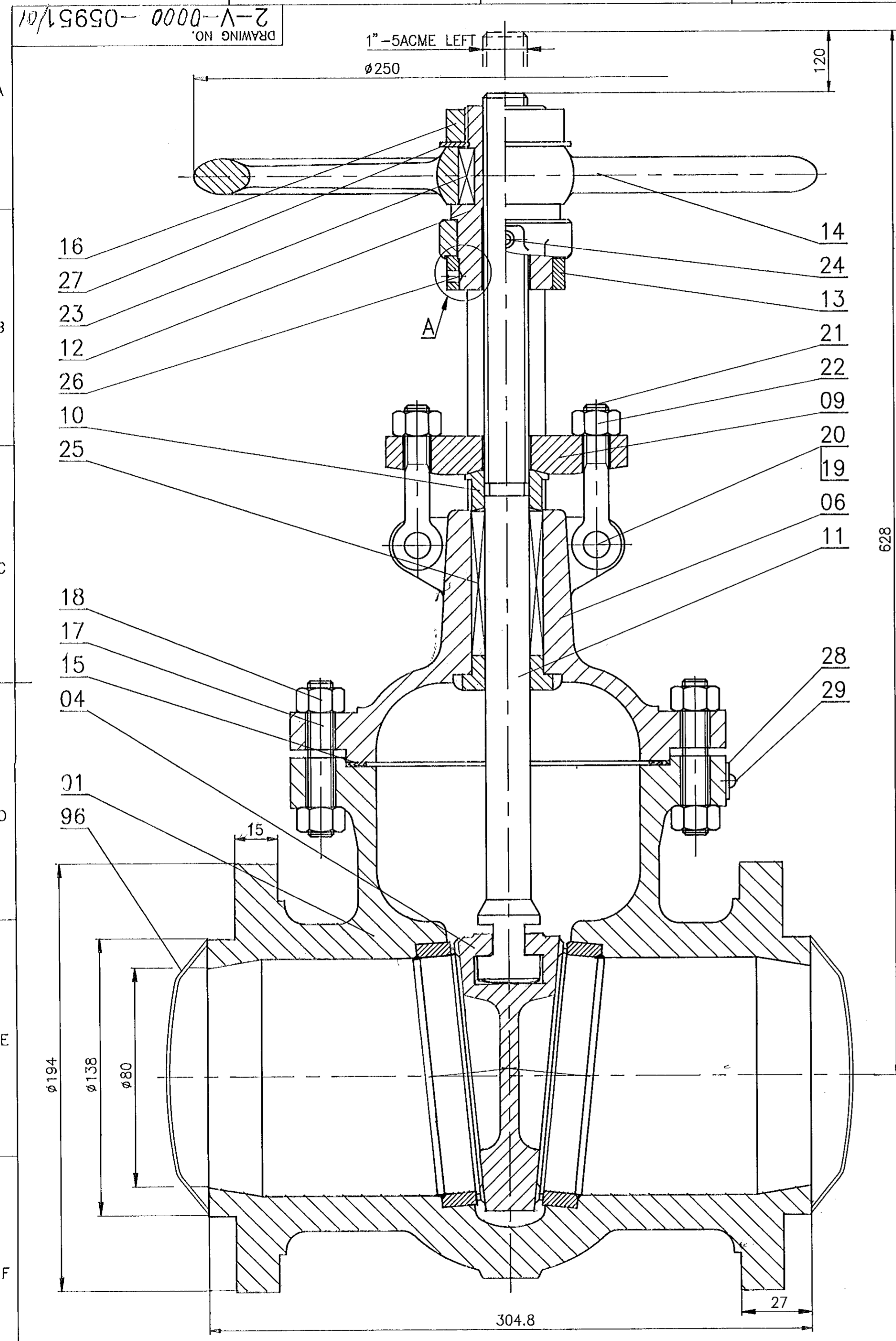

DETAIL-A

DRILL & TAP DURING ASSY.

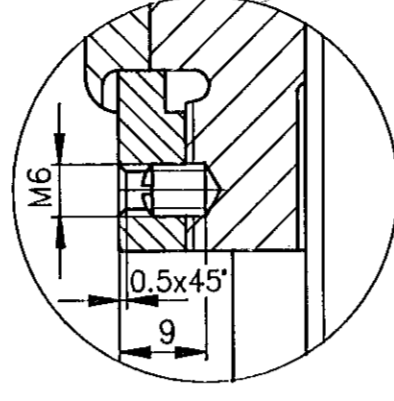

NOTES:

1. THE BUTT WELD END EDGE PREPARATION AS PER PLANT STANDARD AND MAY VARY TO SUIT CUSTOMER'S REQUIREMENT.
2. DIMENSIONALLY IDENTICAL SEAT RING MAY BE EITHER SCREWED OR SCREWED AND SEAL WELD.
3. HYDRAULIC TEST PROCEDURE SHALL BE AS PER PRQE (REFER LATEST REVISION)
4. END COVER SHALL BE TACK WELD AT 3 EQUAL DISTANCED PLACES AFTER EDGE PREPARATION.

SL. No.	TYPE No.	ASSY. DRG No.	MATL. SPECN.	VALVE SPECN.	HYD. TEST PR. IN (Kg/cm ²)		PRESSURE/TEMPERATURE RATINGS															
					SHELL	SEAT	TEMP. IN °C	38	200	300	400	425	-	-	TEMP. IN °C	38	200	300	400	425	-	-
01	N251	2-V-N251-05951	A216 WCB	4"-300C WCB BW GV HW	78	52	TEMP. IN °C	38	200	300	400	425	-	-	TEMP. IN °C	38	200	300	400	425	-	-
02	N252	2-V-N252-05951	A216 WCC	4"-300C WCC BW GV HW	80	53	TEMP. IN °C	38	200	300	400	425	-	-	TEMP. IN °C	38	200	300	400	425	-	-
03	N253	2-V-N253-05951	A217 WC6	4"-300C WC6 BW GV HW	80	53	TEMP. IN °C	38	200	300	400	-	500	550	TEMP. IN °C	38	200	300	400	-	500	550
04	N254	2-V-N254-05951	A217 WC9	4"-300C WC9 BW GV HW	80	53	TEMP. IN °C	38	200	300	400	-	500	550	TEMP. IN °C	38	200	300	400	-	500	550

No OFF	DESCRIPTION	MATL CODE	MATL SPECN	HEAT TREATMENT	SCRAP SORT	NET WT (kg)	GROSS WT (kg)	DRAWING No	ITEM No
TYPE OF PRODUCT OR NAME OF CUSTOMER/PROJECT									
BHARAT HEAVY ELECTRICALS LTD, UNIT: HIGH PRESSURE BOILER PLANT. TIRUCHIRAPALLI - 620014.				DRN	NAME	SIGN	DATE	NO. OF VAR.	
				CHD	N.DHANAPAL	<i>[Signature]</i>	08.10.95		
				APPD	A.VISWANATHAN	<i>[Signature]</i>	13/10/95		
DEPT	VL	SCALE	WEIGHT (KG)	REFERENCE INFORMATIONS			NO. OF ITMS		
CODE	320	NTS.	71.5	CAD:C205951					
TITLE						CARD CODE	DRAWING NO.	REV	
GATE VALVE ASSY.						U 01	2-V-0000-05951	01	

REV 01 DATE 13.10.95 ALTERED T.C. CHD & APPD
 ZONE INCLUDED FOR WCB, WCC & WCG
 S/L Nos REARRANGED

CAUTION: The information on this document is the property of BHARAT HEAVY ELECTRICALS LTD. It must not be used directly or indirectly in any way detrimental to the interest of the company.