

2-V-0000-06194
DRAWING NO.

ALL DIMENSIONS ARE IN MILLIMETRES. FOR TOLERANCES OF UNTOLERANCED DIMENSIONS DURING MANUFACTURE REFER RELEVANT QCP / QP

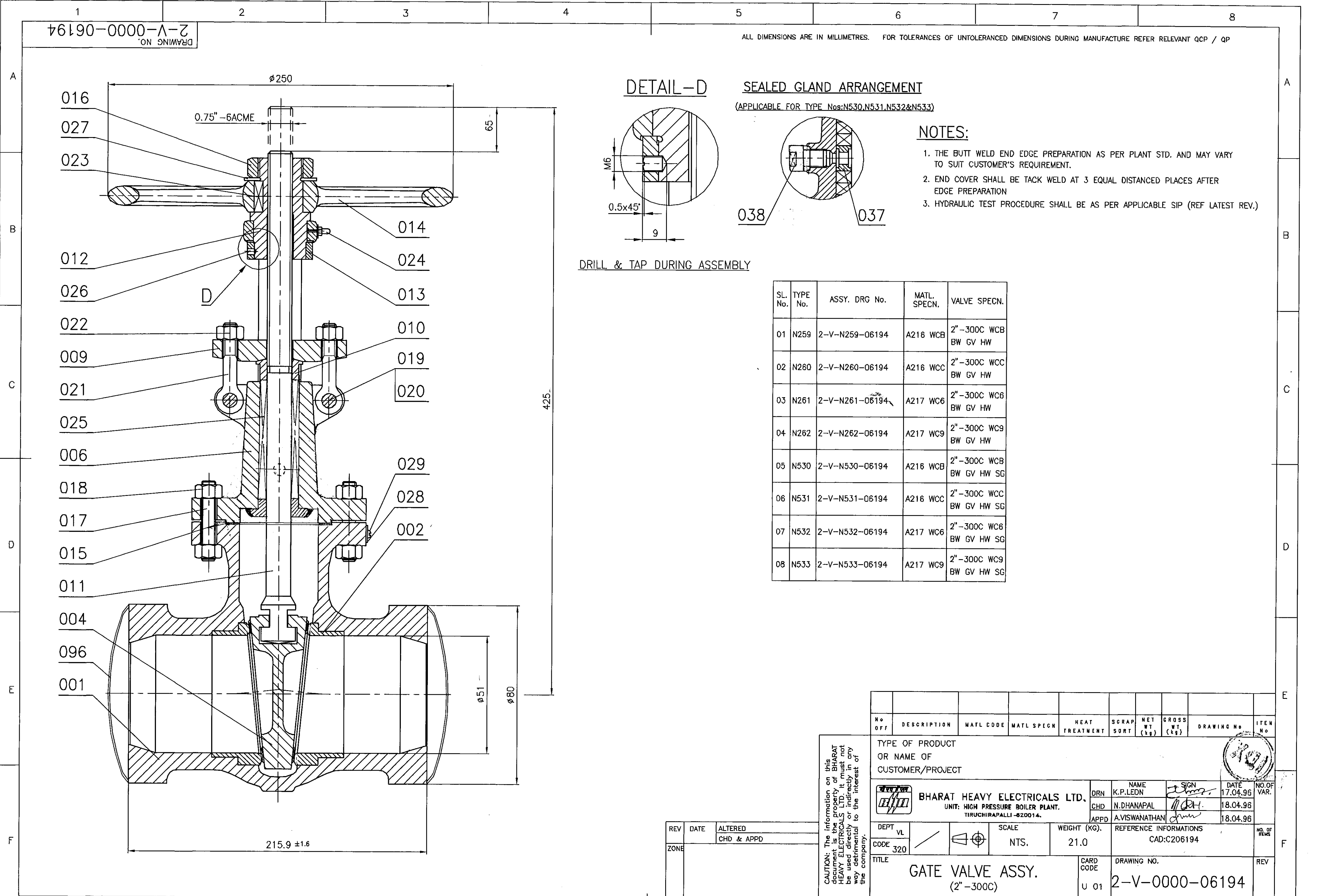

DETAIL-D

SEALED GLAND ARRANGEMENT

(APPLICABLE FOR TYPE Nos: N530, N531, N532 & N533)

NOTES:

1. THE BUTT WELD END EDGE PREPARATION AS PER PLANT STD. AND MAY VARY TO SUIT CUSTOMER'S REQUIREMENT.
2. END COVER SHALL BE TACK WELD AT 3 EQUAL DISTANCED PLACES AFTER EDGE PREPARATION
3. HYDRAULIC TEST PROCEDURE SHALL BE AS PER APPLICABLE SIP (REF LATEST REV.)

DRILL & TAP DURING ASSEMBLY

SL. No.	TYPE No.	ASSY. DRG No.	MATL. SPECN.	VALVE SPECN.
01	N259	2-V-N259-06194	A216 WCB	2"-300C WCB BW GV HW
02	N260	2-V-N260-06194	A216 WCC	2"-300C WCC BW GV HW
03	N261	2-V-N261-06194	A217 WC6	2"-300C WC6 BW GV HW
04	N262	2-V-N262-06194	A217 WC9	2"-300C WC9 BW GV HW
05	N530	2-V-N530-06194	A216 WCB	2"-300C WCB BW GV HW SG
06	N531	2-V-N531-06194	A216 WCC	2"-300C WCC BW GV HW SG
07	N532	2-V-N532-06194	A217 WC6	2"-300C WC6 BW GV HW SG
08	N533	2-V-N533-06194	A217 WC9	2"-300C WC9 BW GV HW SG

No OFF	DESCRIPTION	MATL CODE	MATL SPECN	HEAT TREATMENT	SCRAP SORT	NET WT (kg)	GROSS WT (kg)	DRAWING No	ITEM No
TYPE OF PRODUCT OR NAME OF CUSTOMER/PROJECT									
BHARAT HEAVY ELECTRICALS LTD. UNIT: HIGH PRESSURE BOILER PLANT. TIRUCHIRAPALLI - 620014.				DRN	K.P.LEON	SIGN	DATE	NO. OF	
				CHD	N.DHANAPAL	SIGN	17.04.96	VAR.	
				APPD	A.VISWANATHAN	SIGN	18.04.96		
DEPT	VL	SCALE	WEIGHT (KG).	REFERENCE INFORMATIONS			NO. OF		
CODE	320	NTS.	21.0	CAD:C206194			ITEMS		
TITLE						CARD CODE	DRAWING NO.	REV	
GATE VALVE ASSY. (2"-300C)						U 01	2-V-0000-06194		

REV	DATE	ALTERED
		CHD & APPD
ZONE		