

प्रथम कोण प्रक्षेपण/FIRST ANGLE PROJECTION

सभी विमाएँ मिलीमीटर में हैं।/ALL DIMENSIONS ARE IN mm.

पृष्ठ संख्या 44 (बी)/FORM 44 (B)

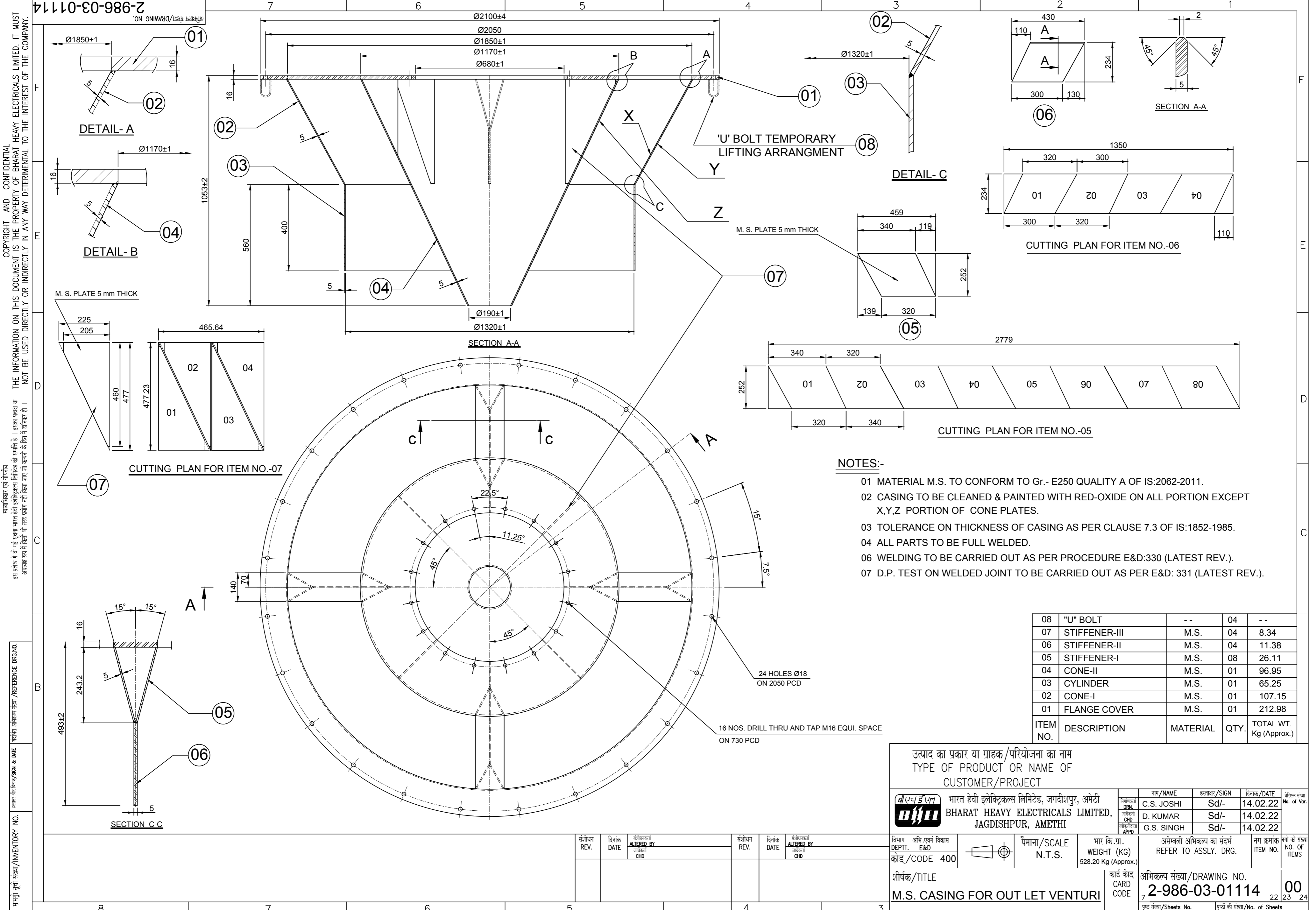

NOTES:-

- 01 MATERIAL M.S. TO CONFORM TO Gr.- E250 QUALITY A OF IS:2062-2011.
- 02 CASING TO BE CLEANED & PAINTED WITH RED-OXIDE ON ALL PORTION EXCEPT X,Y,Z PORTION OF CONE PLATES.
- 03 TOLERANCE ON THICKNESS OF CASING AS PER CLAUSE 7.3 OF IS:1852-1985.
- 04 ALL PARTS TO BE FULL WELDED.
- 06 WELDING TO BE CARRIED OUT AS PER PROCEDURE E&D:330 (LATEST REV.).
- 07 D.P. TEST ON WELDED JOINT TO BE CARRIED OUT AS PER E&D: 331 (LATEST REV.).

ITEM NO.	DESCRIPTION	MATERIAL	QTY.	TOTAL WT. Kg (Approx.)
08	"U" BOLT	--	04	--
07	STIFFENER-III	M.S.	04	8.34
06	STIFFENER-II	M.S.	04	11.38
05	STIFFENER-I	M.S.	08	26.11
04	CONE-II	M.S.	01	96.95
03	CYLINDER	M.S.	01	65.25
02	CONE-I	M.S.	01	107.15
01	FLANGE COVER	M.S.	01	212.98

उत्पाद का प्रकार या ग्राहक/परियोजना का नाम
TYPE OF PRODUCT OR NAME OF CUSTOMER/PROJECT

भारत हेवी इलेक्ट्रिकल्स लिमिटेड, जगदीशपुर, अमेठी
BHARAT HEAVY ELECTRICALS LIMITED, JAGDISHPUR, AMETHI

नाम/NAME	हस्ताक्षर/SIGN	दिनांक/DATE	संशोधन संख्या/No. of Var.
C.S. JOSHI	Sd/-	14.02.22	
D. KUMAR	Sd/-	14.02.22	
G.S. SINGH	Sd/-	14.02.22	

विभाग/DEPTT. E&D
कोड/CODE 400

पैमाना/SCALE N.T.S.

भार कि.गा. WEIGHT (KG) 528.20 Kg (Approx.)

असेम्बली अभिकल्प का संदर्भ REFER TO ASSLY. DRG.

नाम क्रमांक/ITEM NO.

शीर्षक/TITLE
M.S. CASING FOR OUT LET VENTURI

कार्ड कोड/ CARD CODE

अभिकल्प संख्या/DRAWING NO.
2-986-03-01114

पृष्ठ संख्या/Sheets No. 22/23/24

पृष्ठों की संख्या/No. of Sheets

COPYRIGHT AND CONFIDENTIAL
 THE INFORMATION ON THIS DOCUMENT IS THE PROPERTY OF BHARAT HEAVY ELECTRICALS LIMITED. IT MUST NOT BE USED DIRECTLY OR INDIRECTLY IN ANY WAY DETERIMENTAL TO THE INTEREST OF THE COMPANY.
 संपूर्ण सूची संख्या/INVENTORY NO.
 संशोधन और दिनांक/REV. & DATE
 संशोधन और दिनांक/REV. & DATE
 संशोधन और दिनांक/REV. & DATE

प्रथम कोण प्रक्षेपण/FIRST ANGLE PROJECTION

सभी विमाएँ मिलीमीटर में हैं।/ALL DIMENSIONS ARE IN mm.

3-986-03-01113

3-986-03-01113

COPYRIGHT AND CONFIDENTIAL
THE INFORMATION ON THIS DOCUMENT IS THE PROPERTY OF
BHARAT HEAVY ELECTRICALS LIMITED. IT MUST NOT BE USED
DIRECTLY OR INDIRECTLY IN ANY WAY DETERIMENTAL TO THE
INTEREST OF THE COMPANY.

कॉपीराइट एवं गोपनीय
इस प्रलेख में दी गई सूचना भारत हेवी इलेक्ट्रिकल्स लिमिटेड की
संपत्ति है। इसका प्रत्यक्ष या अप्रत्यक्ष रूप में किसी भी तरह
प्रयोग नहीं किया जाए जो कम्पनी के हित में हानिकारक हो।

DIMENSIONS TO BE CONTROLLED
WITHIN LIMITS AS SHOWN
MACHINING TOLERANCE ±0.25 mm
UNLESS OTHERWISE SHOWN
NON-MACHINING TOLERANCE ±0.5 mm

संशोधन अथवा संख्या
REFERENCE DRG. NO.

हस्ताक्षर और दिनांक/SIGN & DATE

सामग्री संख्या
INVENTORY NO.

LOCATION OF "PATTERN NO."

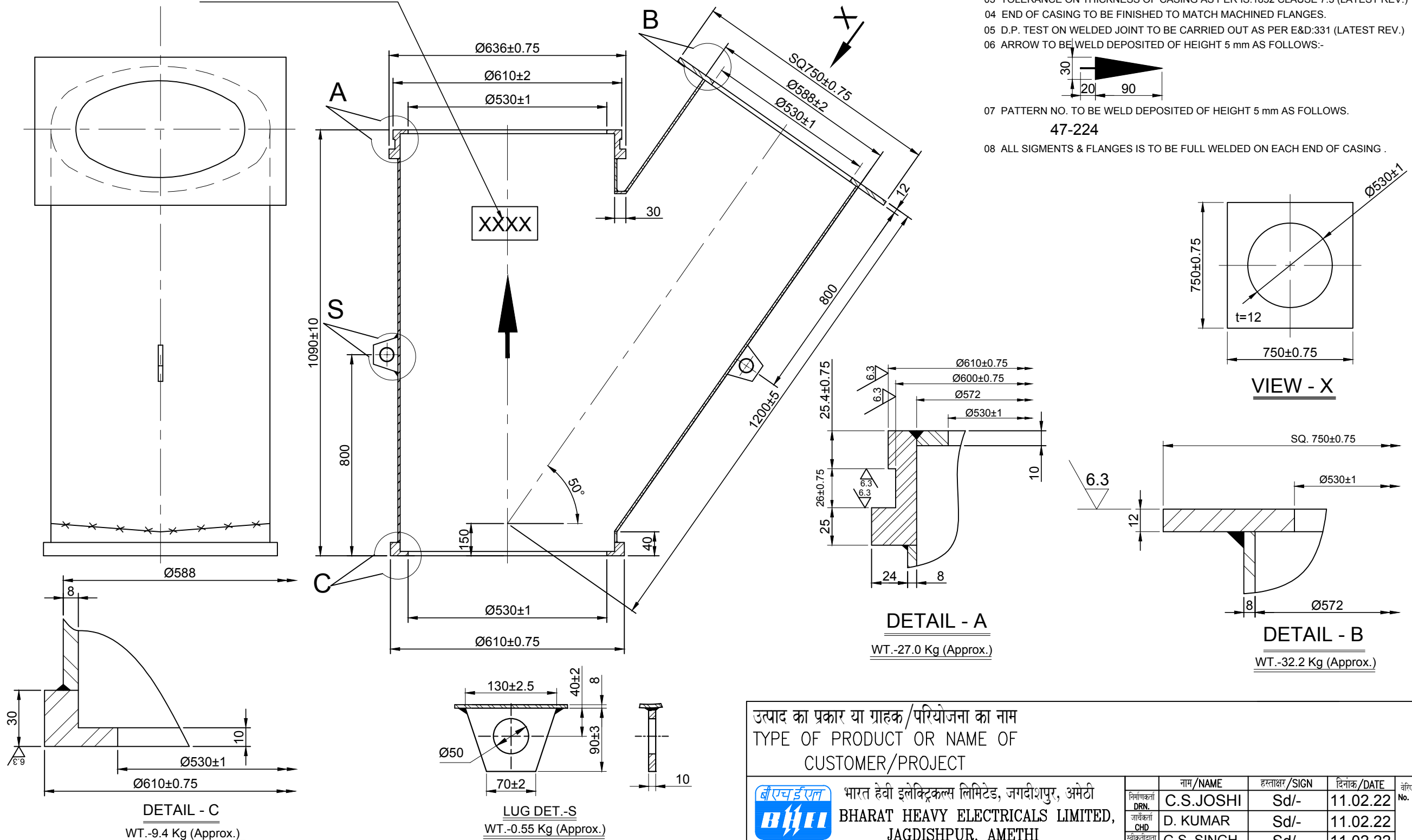

NOTES:-

- 01 MATERIAL M.S. TO CONFORM TO IS:2062 Gr.-E250 QUALITY A (LATEST REV.)
- 02 CASING TO BE CLEANED & PAINTED WITH RED-OXIDE ON OUTSIDE ONLY .
- 03 TOLERANCE ON THICKNESS OF CASING AS PER IS:1852 CLAUSE 7.3 (LATEST REV.)
- 04 END OF CASING TO BE FINISHED TO MATCH MACHINED FLANGES.
- 05 D.P. TEST ON WELDED JOINT TO BE CARRIED OUT AS PER E&D:331 (LATEST REV.)
- 06 ARROW TO BE WELD DEPOSITED OF HEIGHT 5 mm AS FOLLOWS:-

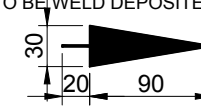

07 PATTERN NO. TO BE WELD DEPOSITED OF HEIGHT 5 mm AS FOLLOWS.

47-224

08 ALL SIGMENTS & FLANGES IS TO BE FULL WELDED ON EACH END OF CASING .

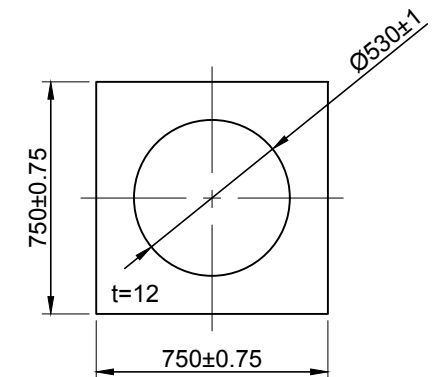

VIEW - X

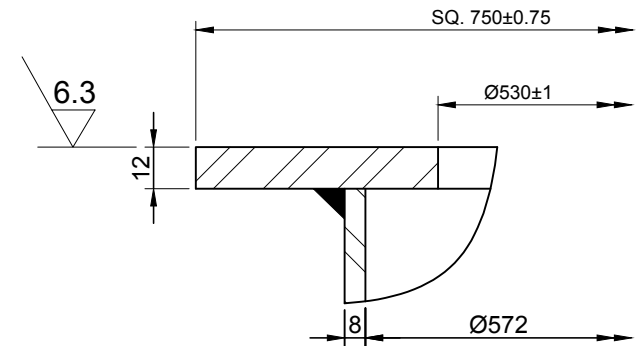

DETAIL - B

WT.-32.2 Kg (Approx.)

DETAIL - A

WT.-27.0 Kg (Approx.)

DETAIL - C

WT.-9.4 Kg (Approx.)

LUG DET.-S

WT.-0.55 Kg (Approx.)

उत्पाद का प्रकार या ग्राहक/परियोजना का नाम
TYPE OF PRODUCT OR NAME OF
CUSTOMER/PROJECT

भारत हेवी इलेक्ट्रिकल्स लिमिटेड, जगदीशपुर, अमेठी
BHARAT HEAVY ELECTRICALS LIMITED,
JAGDISHPUR, AMETHI

नाम/NAME	हस्ताक्षर/SIGN	दिनांक/DATE	वेरिफाई संख्या No. of Ver.
C.S.JOSHI	Sd/-	11.02.22	
D. KUMAR	Sd/-	11.02.22	
G.S. SINGH	Sd/-	11.02.22	

विभाग DEPTT. ENGG.	अभियंत्रिका ENGG.	पैमाना/SCALE N.T.S.	भार.क्रि.गा. WEIGHT (KG) 272.4 Kg (Approx.)	असेम्बली अभिकल्प का संदर्भ REFER TO ASSLY. DRG.	नग क्रमांक ITEM NO.	नगों की संख्या NO. OF ITEMS
-----------------------	----------------------	------------------------	---	--	------------------------	--------------------------------

शीर्षक/TITLE M.S. CASING FOR T-PIECE (I.D-530)	कार्ड कोड CARD CODE	अभिकल्प संख्या/DRAWING NO. 3-986-03-01113	REV. 00
--	------------------------	---	-------------------

पृष्ठ संख्या/Sheets No. 01 पृष्ठों की संख्या/No. of Sheets 01

A3 साइज़/A3 SIZE

प्रथम कोण प्रक्षेपण/FIRST ANGLE PROJECTION

सभी विमाएं मिलीमीटर में हैं।/ALL DIMENSIONS ARE IN mm.

COPYRIGHT AND CONFIDENTIAL
THE INFORMATION ON THIS DOCUMENT IS THE PROPERTY OF
BHARAT HEAVY ELECTRICALS LIMITED. IT MUST NOT BE USED
DIRECTLY OR INDIRECTLY IN ANY WAY DETERIMENTAL TO THE
INTEREST OF THE COMPANY.

स्वाधिकार एवं गोपनीय
इस प्रलेख में दी गई सूचना भारत हेवी इलेक्ट्रिकल्स लिमिटेड की
सम्पत्ति है। इसका प्रयोग या अनुवाद बिना लिखित अनुमति के
प्रयोग नहीं किया जाए जो कम्पनी के हित में होना चाहिए।

DIMENSIONS TO BE CONTROLLED
WITHIN LIMITS AS SHOWN
MACHINING TOLERANCE ±0.25 mm
UNLESS OTHERWISE SHOWN
NON-MACHINING TOLERANCE ±0.5 mm

संदर्भित अभिकल्प संख्या
REFERENCE DRG. NO.

हस्ताक्षर और दिनांक/SIGN & DATE

सामग्री संख्या
INVENTORY NO.

3-986-03-01112
अभिकल्प संख्या/DRAWING NO.

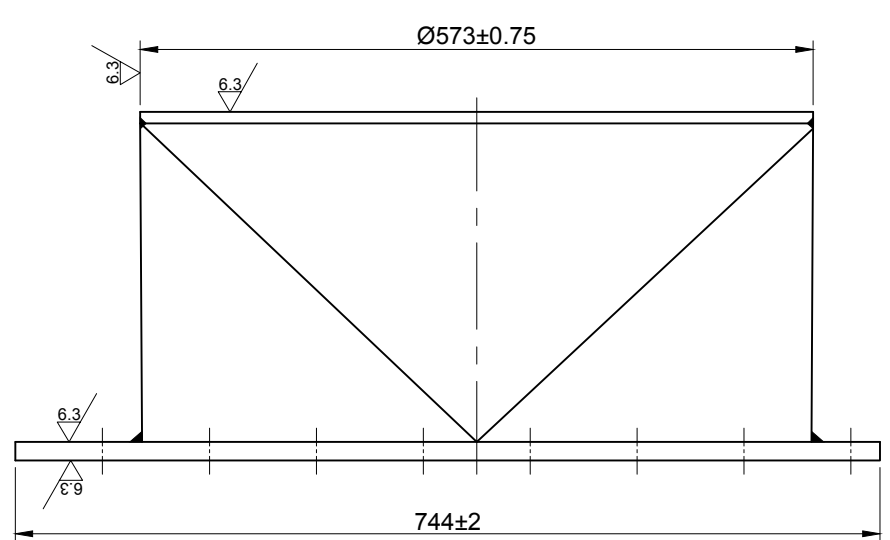
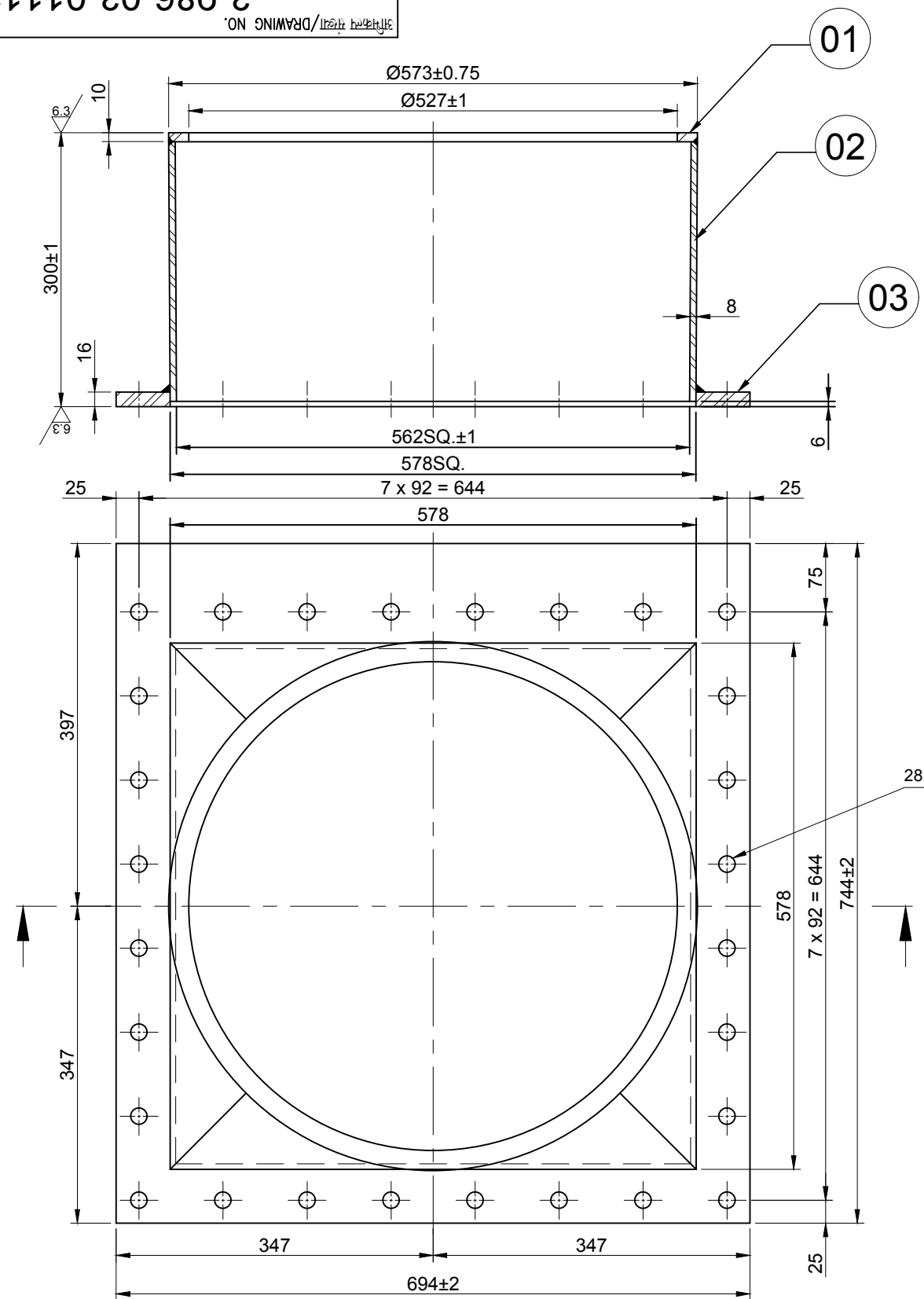

NOTES:-

- 01 MATERIAL M.S. CONFORM TO IS:2062 Gr.-A (LATEST REV.).
- 02 CASING TO BE CLEANED & PAINTED WITH RED-OXIDE ON OUTSIDE ONLY.
- 03 TOLERANCE ON THICKNESS OF CASING AS PER IS:1852 CLAUSE 7.3 (LATEST REV.).
- 04 D.P. TEST ON WELDED JOINT TO BE CARRIED OUT AS PER E&D:331 (LATEST REV.).
- 05 FLANGE IS TO BE FULL WELDED ON EACH END OF CASING .
- 06 MFG. & INSP. SHOULD BE DONE AS PER E&D:306 (LATEST REV.).
- 07 WELDING & PAINTING TO BE DONE AS PER PROCEDURE E&D:330 (LATEST REV.).

ITEM NO.	DESCRIPTION	MATERIAL	QTY.	WT./UNIT Kg (Approx.)
03	BOTTOM FLANGE	M.S.	01	27.0
02	CASING	M.S.	01	28.63
01	TOP RING	M.S.	01	3.12

उत्पाद का प्रकार या ग्राहक/परियोजना का नाम
TYPE OF PRODUCT OR NAME OF
CUSTOMER/PROJECT

नाम/NAME	हस्ताक्षर/SIGN	दिनांक/DATE	वेरिफाई संख्या No. of Ver.
C.S.JOSHI	Sd/-	11.02.22	
D.KUMAR	Sd/-	11.02.22	
G.S.SINGH	Sd/-	11.02.22	

विभाग DEPTT.	अभियंत्रिकी ENGG.	पैमाना/SCALE	भार क्रि.गा. WEIGHT (KG)	असेम्बली अभिकल्प का संदर्भ REFER TO ASSLY. DRG.	नग क्रमांक ITEM NO.	नगों की संख्या NO. OF ITEMS
कोड/400		N.T.S.	58.75 (Approx.)			

शीर्षक/TITLE	कार्ड कोड CARD CODE	अभिकल्प संख्या/DRAWING NO.	REV.
TRANSITION PIECE		3-986-03-01112	00

पृष्ठ संख्या/Sheets No. 01 पृष्ठों की संख्या/No. of Sheets 01

THE INFORMATION ON THIS DOCUMENT IS THE PROPERTY OF BHARAT HEAVY ELECTRICALS LIMITED.
IT MUST NOT BE USED DIRECTLY OR INDIRECTLY IN ANY WAY DETRIMENTAL TO THE INTEREST OF THE COMPANY

INVENTORY NO.	SIGN. AND DATE	REF. DRG. NO.	COMP. FILE NAME
			06250603.DWG

NO. 15
DRG. SHEET

FIRST ANGLE PROJECTION

(ALL DIMENSIONS ARE IN MM)

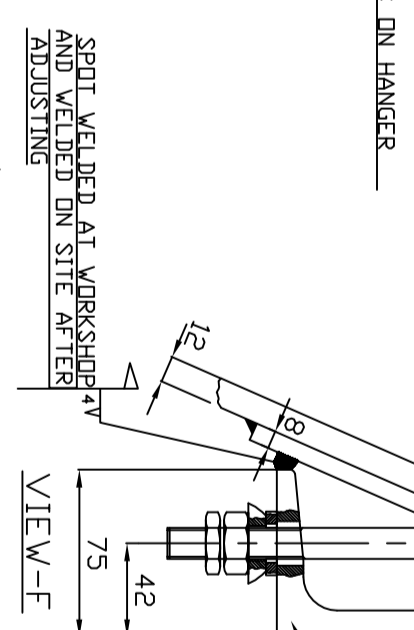
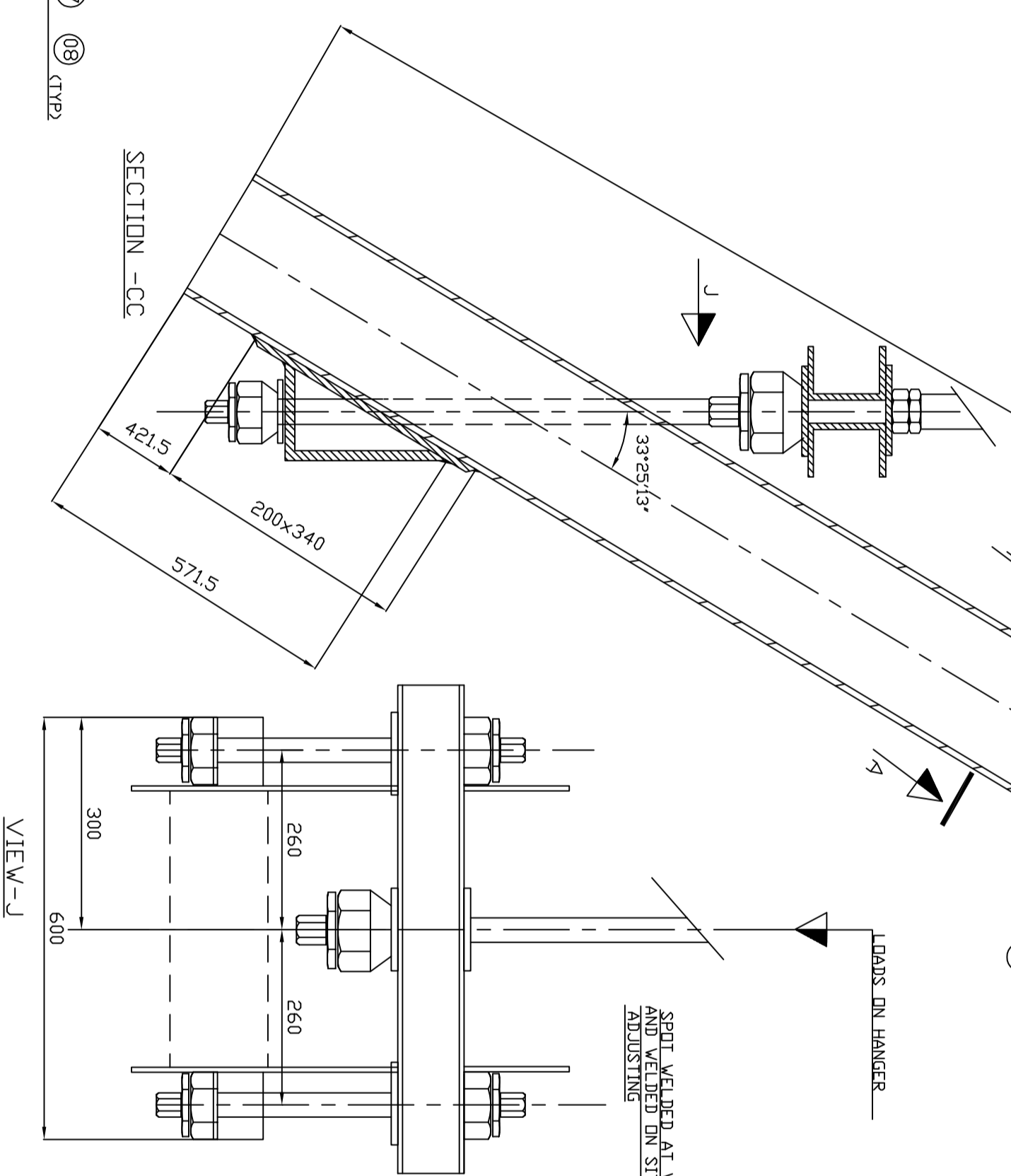
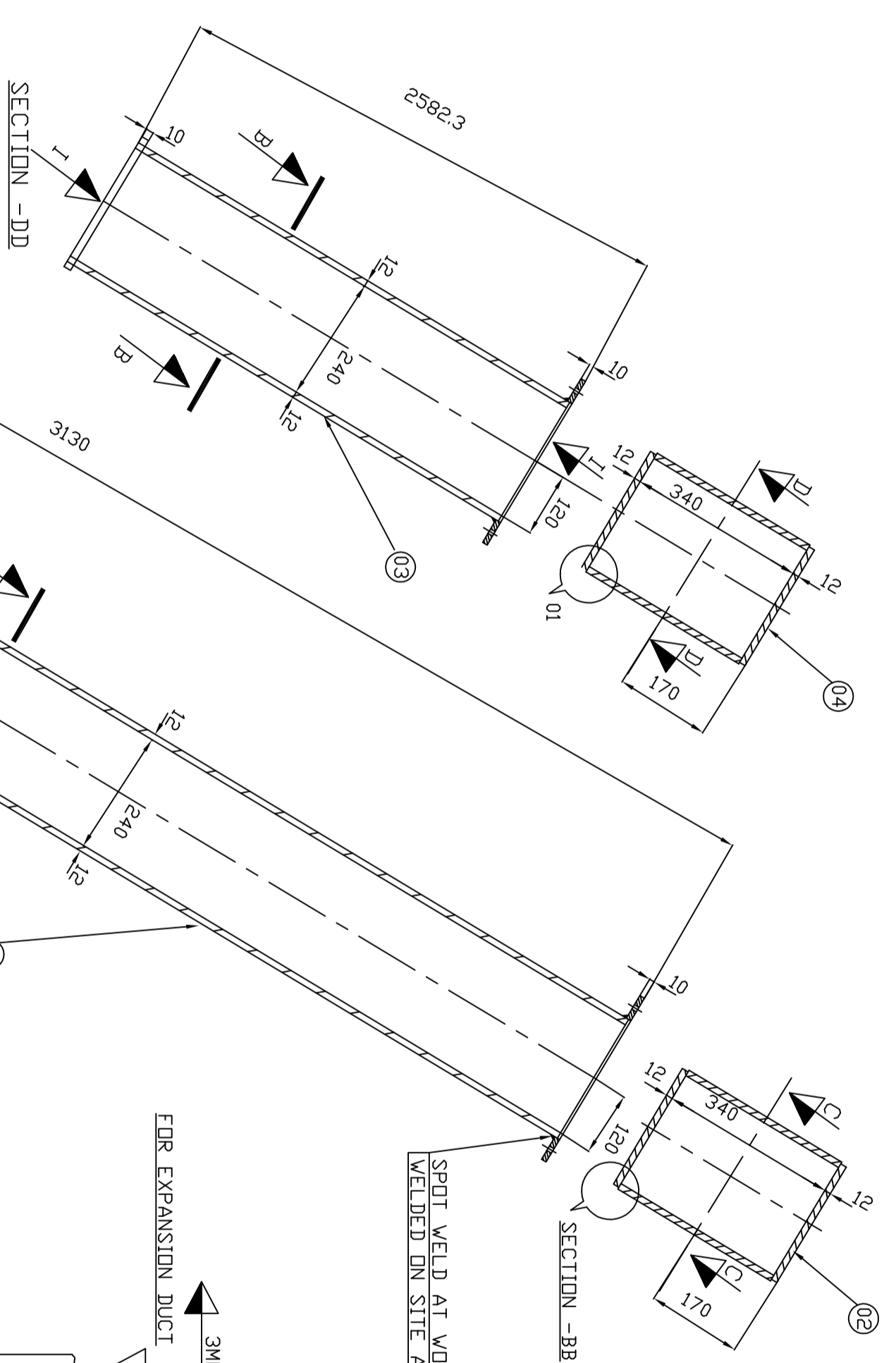
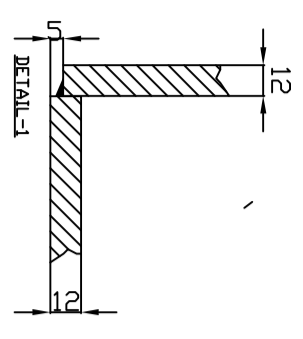
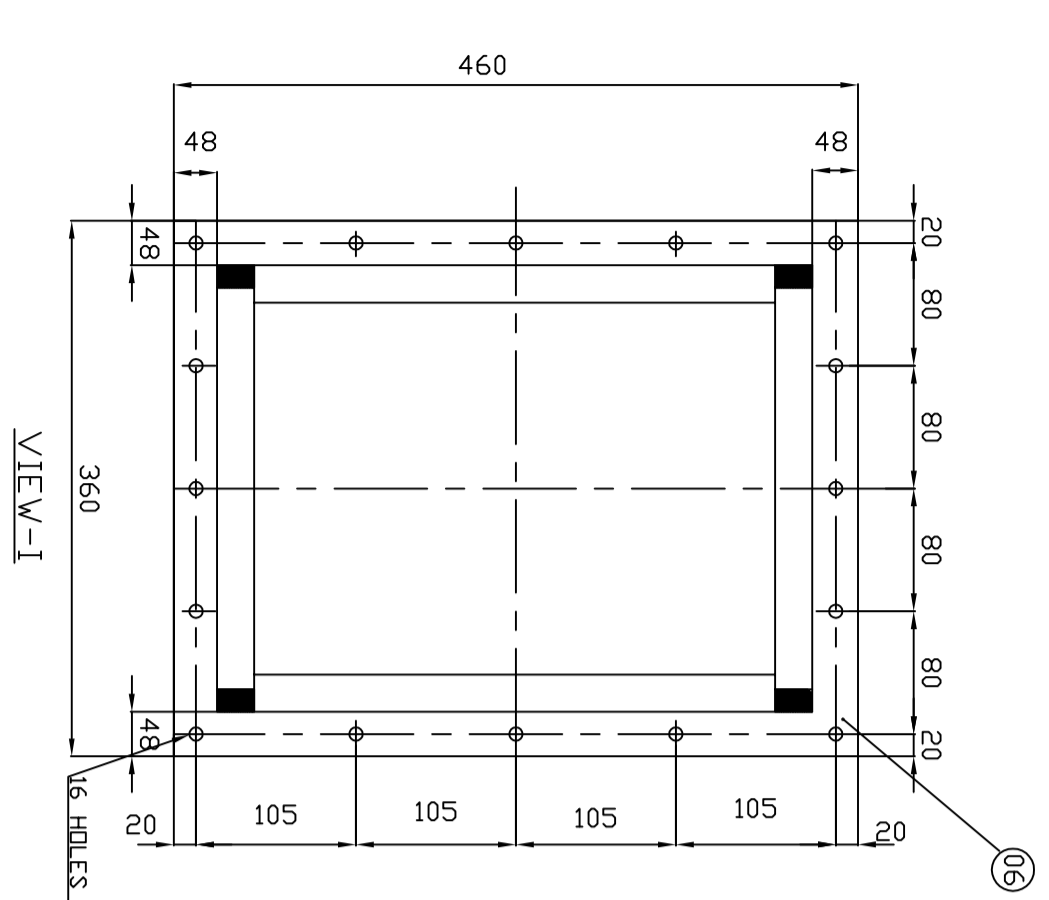
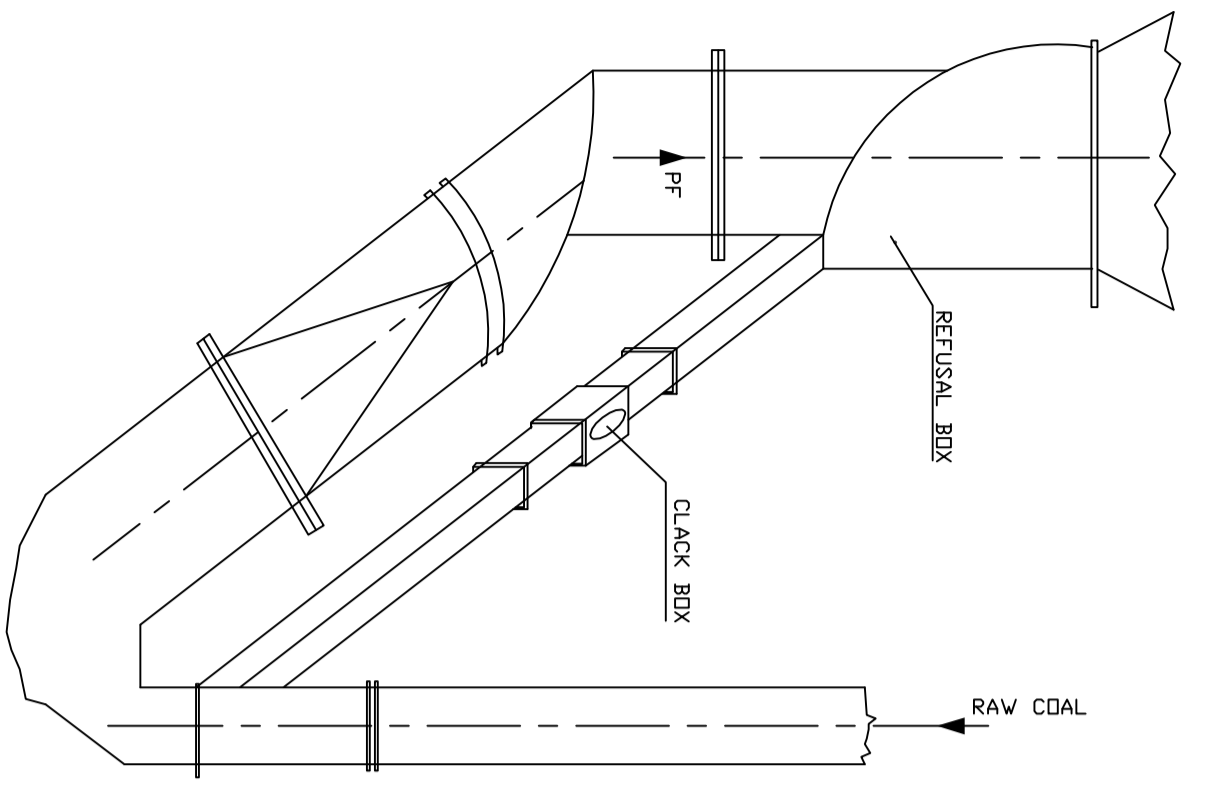

SPOT WELD AT WORKSHOP & WELDED ON SITE AFTER ADJUSTMENT

FDR EXPANSION DUCT

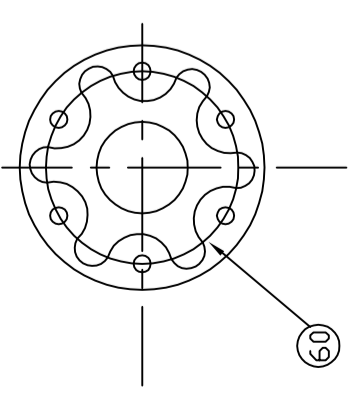

ASSEMBLY OF FLANGE DETAIL

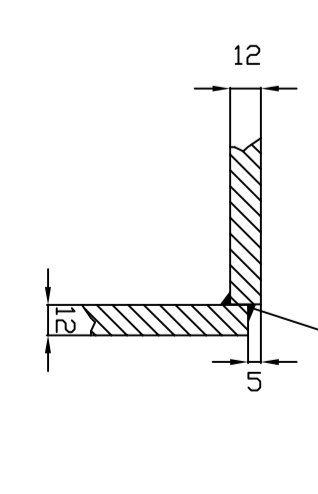

NOTE- 01 INTER FLANGES TIGHTENED INSURED WITH CERAMIC FIBRE CORD
02 DIA8 COMPRESSED TO 5MM
EG MEANS AIR TIGHT WELDED & TO BE ENSURED BY 'DP' TEST

ITEM NO.	DESCRIPTION	DRAWING NO.	QTY	UNIT	GROUP WT.	QUANTITY
10	ANGLE MC 150X75	AA1012708063	10.080			
09	CERAMIC CORD 88-2M LONG	HY5410262061	0.050			
08	HEX NUT M 16-F8	AA715115059	0.024			
07	HEX HD BOLT M 16X50-F8.8	AA711112240	4.8			
06	FLANGE PL 10X350X40	AA101181904	5.500			
05	PL 8X200X340	AA1011808056	4.270			
04	PL 12X254X2572	HY1051876995	61.5			
03	PL 12X340X2572	HY10575	82.3			
02	PL 12X254X3125	HY1051876995	74.770			
01	PL 12X340X3125	HY10575	100.100			

THE FOLLOWING CONDITIONS APPLY EXCEPT OTHERWISE STATED.		TYPE OF PRODUCT	
1. REF TO HORIZONTAL FOR	2. CHANGES W/O. SHOP DROPS 1.2 TO 1.0	BHARAT HEAVY ELECTRICALS LIMITED	
3. MATERIAL W/O. CHANGES FROM 1 TO 07	4. THE DIMENSIONS SHOWN ARE THE DIMENSIONS SHOWN ON THE DRAWING UNLESS OTHERWISE STATED	REFUSAL DUCT	
5. DIMENSIONS ARE IN MM UNLESS OTHERWISE STATED	6. DIMENSIONS ARE IN MM UNLESS OTHERWISE STATED	DRAWING NO. 01	

	CORPORATE PURCHASING SPECIFICATION	AA10108
		Rev No. 11
		PAGE 1 of 2

STRUCTURAL STEEL-STANDARD QUALITY (PLATES, SECTIONS, STRIPS, FLATS & BARS)

(ORDERING DESCRIPTION)

1.0 GENERAL:

This specification governs the quality requirements of structural steel plates, strips, flats, bars and sections such as angles, beams, channels and tees etc. of IS: 2062 – 2011, Gr: E250, Quality A

2.0 APPLICATION:

For general engineering purpose.

3.0 CONDITION OF DELIVERY:

Plates, Bars & Sections: Hot rolled in straight lengths without twists & Bends

4.0 COMPLIANCE WITH NATIONAL STANDARDS:

Material shall comply with the requirements of IS: 2062 – 2011, Gr: E250, Quality A

Material offered to EN 10025-2:2004 Gr. S275JR is also acceptable. The tolerance on dimensions for plates shall comply with EN 10029.

5.0 DIMENSIONS AND TOLERANCES:

5.1 DIMENSIONS:

5.1.1 Sizes

Material shall be supplied to the dimensions specified on BHEL Order.

5.1.2 Length

Unless otherwise specified, hot rolled bars and sections shall be supplied in 3 to 6 metres length.

5.2 Tolerances:

5.2.1 The tolerances on hot rolled material shall comply with IS: 1852. However, no plate shall be under the specified thickness at any point.

Revisions: As per Cl. No. 38.1 of MOM of MRC-S&GPS			APPROVED: INTERPLANT MATERIAL RATIONALISATION COMMITTEE – MRC(S&GPS)		
Rev No.11	Amd No.	Reaffirmed	Prepared	Issued	Dt. of 1 st Issue
Dt:22-02-2014	Dt:	Year:	HPEP, Hyderabad	Corp.R&D	July, 1976

AA10108

Rev No. 11

PAGE 2 of 2

CORPORATE PURCHASING SPECIFICATION



5.2.2 Straight for hot rolled bars:

Unless otherwise specified, the permissible deviation in straightness shall not exceed 5 mm in any 1000 mm length.

6.0 HARDNESS (BRINELL):

When tested in accordance with IS: 1500, the material shall show a brinell hardness in the range of 120-156 HB.

Note: Hardness test shall be conducted only when tensile test cannot be performed.

7.0 TEST CERTIFICATES:

Unless otherwise specified, three copies of test certificates shall be supplied.

In addition, the supplier shall ensure to enclose one copy of the test certificate along with their dispatch documents to facilitate quick clearance of the material.

The test certificate shall bear the following information.

AA10108 Rev.11 / IS:2062 Grade: E250 Quality A / EN 10025-2 Gr. S275JR,

BHEL order no., Melt no. Size, Results of chemical analysis and Mechanical tests, Supplier's name, Identification no. TC no., Signature of competent authority etc.

8.0 PACKING AND MARKING:

Plates shall be transported suitably to avoid damage during transit.

For plates below 10 mm thick, each pile (preferably of 16 plates) and each plate 10 mm thick & over shall be marked with melt no. AA10108, BHEL order no., Supplier's name, Identification no., Size & weight on any one corner and encircled with paint preferably of white colour.

9.0 REFERRED STANDARDS (Latest publications including amendments):

1) IS: 1500

2) IS: 1852

3) EN 10029



CORPORATE PURCHASING SPECIFICATION

AA10119

Rev No. 15

PAGE 1 of 2

STRUCTURAL STEEL - WELDABLE QUALITY (PLATES, SECTIONS, STRIPS, FLATS AND BARS)

ORDERING DESCRIPTION

1.0 GENERAL:

The material shall conform to IS 2062 – 2011, E250-Gr.BR (with mandatory Impact Test) or DIN EN 10025-2:2005, Gr. S275JR and comply with following additional requirements.

2.0 APPLICATION:

For general engineering purposes, suitable for welding.

3.0 CONDITION OF DELIVERY:

3.1 Bars & Sections shall be supplied in Hot rolled in straight lengths without twists and bends.

3.2 The material shall be supplied as per IS: 2062 – 2011, E250 Gr.BR (with mandatory Impact Test) or as per DIN EN 10025-2:2005 Gr. 275JR.

3.3 Any other additional requirement as per BHEL Purchase order.

4.0 DIMENSIONS AND TOLERANCES:

4.1 Sizes:

Material shall be supplied to the dimensions specified in BHEL Order.

4.2 Tolerances:

The tolerances on hot rolled material shall comply with IS: 1852 or any other equivalent national standard.

4.3 Straightness for hot rolled bars:

Unless otherwise specified, the permissible deviation in straightness shall not exceed 5 mm in any 1000 mm length.

5.0 TEST SAMPLES:

The selection of test pieces for all tests like Chemical, Mechanical etc. shall be as per IS: 2062, E250-Gr.BR or DIN EN 10025-2, Gr. S275JR.

Revisions:

Clause No. 1, 3, 5 & 8 revised (as per MOM of 38th MRC meeting), Clause 10 added

APPROVED:

INTERPLANT MATERIAL RATIONALISATION
COMMITTEE – MRC(S&GPS)

Rev No.15

Amd No.

Reaffirmed

Prepared

Issued

Dt. of 1st Issue

Dt:11-03-2014

Dt:

Year:

HPEP, Hyderabad

Corp.R&D

June, 1976

AA10119

Rev No. 15

PAGE 2 of 2

CORPORATE PURCHASING SPECIFICATION



6.0 ULTRASONIC EXAMINATION:

Plates shall be ultrasonically examined in accordance with BHEL standard AA0850120 (or ASTM-A435) as detailed below and shall comply with the acceptance standards specified therein.

6.1 For plates above 40 mm thick:

Shall be ultrasonically examined unless when otherwise specified in order.

7.0 TEST CERTIFICATES:

Unless otherwise specified, three copies of test certificates shall be supplied.

In addition, the supplier shall ensure to enclose one copy of the test certificate along with their dispatch documents to facilitate quick clearance of the material.

The test certificate shall bear the following information:

AA10119 - Rev.No.15/ IS: 2062-Gr: BR (with mandatory Impact test) or DIN EN 10025-2, Gr. S275JR,

BHEL order No.

Melt No, Size & Quantity, Batch No with heat treatment details, Results of Chemical analysis,

Mechanical tests & NDT, Supplier's name, Identification No, TC No, Signature of Competent Authority, etc.

8.0 PACKING AND MARKING:

Plates shall be transported suitably to avoid damage during transit.

Each plate shall be marked with Melt No. Material grade and specification, BHEL Order No, Supplier's Name Identification No, Size & weight, on any one corner and encircled with paint preferably of white colour.

9.0 REJECTION AND REPLACEMENT

If the material does not comply with the requirements of this specification during receipt inspection at BHEL or if any defect is found during further processing of material, BHEL reserves the right to reject the whole consignment and the supplier shall replace the material free of cost. The rejected material shall be taken back by the supplier after fulfilling the commercial terms and conditions.

10.0 REFERRED STANDARDS (Latest publications including amendments):

1) IS: 1852

2) ASTM - A435

3) AA0850120



CORPORATE STANDARD

AA7121123

Rev. No. 09

PAGE 1 of 3

SCREWS, HEXAGON HEAD, PRODUCT GRADE 'A' COARSE PITCH, STEEL, PROPERTY CLASS 8.8 (M6 - M24)

1 DESIGNATION

A product Gr. A hexagon head, steel screws of thread M8, length 50mm, coarse pitch and conforming to property class 8.8 shall be designated as:

1.1 On drawings

- i) Material specification column: AA7121123
- ii) Description column: SCRU HEX A M8X50 - 8.8

1.2 On indents:

Screws Hex A M8 X 50 - 8.8; AA7121123

1.3 For issuing enquiries and on purchase orders:

While issuing enquiries and purchase orders delete BHEL standard number from the above description and add the information given under clause 2.

2 COMPLIANCE WITH STANDARDS

2.1 Dimensions, tolerances and general Requirements

As per IS 1364 : Part 2 : 2018

2.2 Mechanical Properties:

To conform to property class 8.8 as specified in Table - 3 of IS: 1367, Part 3.

Permissible hardness 238-350 HB for sizes M6-M10.

2.3 Threads

Pitch-coarse to IS: 4218, Part 2.

Tolerance quality - Medium.

Tolerance class - 6g.

2.4 Identification Marking:

As stated in clause 10 of IS 1367 : Part 3.

2.5 Surface Discontinuity

As per IS 1367 : Part 9 : Sec 1.

2.6 Finish

Plated as specified in BHEL order

Revisions:

APPROVED:

INTERPLANT MATERIAL RATIONALISATION
COMMITTEE – MRC (Fasteners)

Rev. No. 09

Amd. No.

Reaffirmed

Prepared

Issued

Dt. of 1st Issue

Dt: 20-03-2021

Dt:

Year:

HEEP, Haridwar

Corp. R&D

01-01-1977

AA7121123

Rev. No. 09

PAGE 2 of 3

CORPORATE STANDARD**3 NOTE**

3.1 Length and diameter combination (refer Table 1 on page 3 of 3) between the bold lines should only be used.

3.2 For screw threads, general (Metric) refer to BHEL standard AA0231800.

3.3 For tolerance grade, position and class refer to BHEL standard AA0230201.

3.4 Screws to this standard would be un-plated; divisions wishing to have plated bolts would have to get them plated.

3.5 Weights given in this standard are for general reference only and are not for commercial transactions.

3.6 When fasteners are to be tested with in BHEL, the sampling and acceptance plan shall be as per IS: 1367, Part 17.

4 REFERRED STANDARDS (Latest publications including amendment)

- 1) IS: 1364, Part.2
- 2) IS: 1367 Part.3, 9 : Sec 1 & 17
- 3) IS: 4218, Part.2
- 4) AA0230201
- 5) AA0231800
- 6) AA0231850

EXPLANATORY NOTE

The following changes have been made in the revision:

- In Clause 2.1, year of IS updated to 2018.
- In Clause 2.4, clause 10 in place of clause 9.2.1
- Clause 2.5, updated.

	<h1>CORPORATE STANDARD</h1>	AA7164002
		Rev. No. 06
		PAGE 1 of 3

WASHERS, SPRING LOCK, SINGLE COIL, RECTANGULAR SECTION, TYPE-B (WITH FLAT ENDS), STEEL

1.0 DESIGNATION

A single coil, rectangular section, spring lock washer, Type-B (with flat ends) for right hand threads, of nominal size 5 mm, and made of steel shall be designated as

1.1 On Drawings

- i) Material specification column - AA7164002
- ii) Description column - WASHER SPRING LOCK SC B5 – St

1.2 On Indents

Washer Spring Lock B5; AA7164002

1.3 For issuing enquiries and on purchase orders

While issuing enquiries and purchase orders, delete the BHEL Standard No. from the above description and add the information given under clause 2.0

2.0 COMPLIANCE WITH STANDARDS

2.1 Dimensions, Tolerances and General Requirements

To IS: 3063-1994, Reaffirmed 2010 Type-B (Table – 1A)

2.2 Material

Spring steel Gr.3 to Gr.6, as specified in IS: 4072

2.3 Heat Treatment and Hardness

Spring washer after coiling shall be suitably heat treated, so as to result in the finished washer having hardness in the range of 430-530 HV

2.4 Finish

Unplated.

Revisions:
As per clause 32.2 of MOM of MRC-F

APPROVED:
INTERPLANT MATERIAL RATIONALISATION
COMMITTEE – MRC (F)

Rev. No. 06	Amd. No.	Reaffirmed	Prepared	Issued	Dt. of 1 st Issue
Dt: 06-09-2014	Dt:	Year:	HPEP, Hyderabad	Corp. R&D	01-01-1977

AA7164002

Rev. No. 06

PAGE 2 of 3

CORPORATE STANDARD**3.0 NOTE**

- 3.1** For washers spring lock, Type-A refer BHEL Corporate Standard AA7164001
- 3.2** Lock washers to this standard would be unplated, divisions wishing to have plated washers would have to get them plated.
- 3.3** Weights given in this standard are for general reference only and are not meant for commercial transactions.
- 3.4** When the fasteners are to be tested within BHEL, the following sampling and acceptance plan based on IS: 6821 (Table-1) shall be followed as detailed below for physical properties.

Lot Size	Sample Size	Acceptance No.
Up to 1000	5	0
1001-3000	8	0
3001-10000	13	0
10001-35000	20	0
Over 35000	32	1

4.0 Referred standards (Latest Publications including Amendments)

- 1) IS: 4072
- 2) AA7164001
- 3) IS: 6821



CORPORATE STANDARD

AA7164002

Rev. No. 06

PAGE 3 of 3

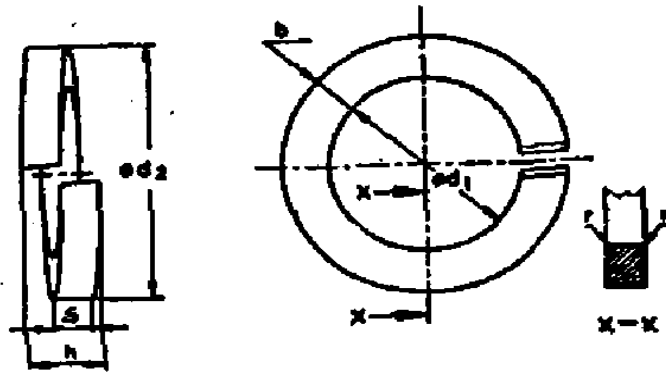

FIG-1

Note:

- 1) Corporate sub code numbers only are shown in Table-1
- 2) Weights have been shown in kg per 1000 Nos.

TABLE-1

All dimensions are in 'mm'

Nom size	Internal Dia. d_1		Outside Dia. d_2	Width b		Thickness s		Radius r	For Bolt, Nut or Screw size	Sub-Code	Weight
	Basic	Tol +		Max.	Basic	Tol \pm	Basic				
2	2.1	0.3	4.4	0.9	0.1	0.5	0.1	0.1	M2		0.033
2.2	2.3	0.3	4.8	1.0	0.1	0.6	0.1	0.1	M2.2		0.050
2.5	2.6	0.3	5.1	1.0	0.1	0.6	0.1	0.1	M2.5		0.053
3.0	3.1	0.3	6.2	1.3	0.1	0.8	0.1	0.2	M3	010	0.11
4.0	4.1	0.3	7.6	1.5	0.1	0.9	0.1	0.2	M4	029	0.18
5.0	5.1	0.3	9.2	1.8	0.1	1.2	0.1	0.2	M5	037	0.36
6.0	6.1	0.4	11.8	2.5	0.15	1.6	0.1	0.3	M6	045	0.83
8.0	8.1	0.4	14.8	3.0	0.15	2.0	0.1	0.5	M8	053	1.60
10.0	10.2	0.5	18.1	3.5	0.2	2.2	0.15	0.5	M10	061	2.53
12.0	12.2	0.5	21.1	4.0	0.2	2.5	0.15	1.0	M12	070	3.82
16.0	16.2	0.8	27.4	5.0	0.2	3.5	0.2	1.0	M16	088	8.91
20.0	20.2	1.0	33.6	6.0	0.2	4.0	0.2	1.0	M20	096	15.2
24.0	24.5	1.0	40.0	7.0	0.25	5.0	0.2	1.6	M24	100	26.2
30.0	30.5	1.2	48.2	8.0	0.25	6.0	0.2	1.6	M30	118	44.3
36.0	36.5	1.2	58.2	10.0	0.25	6.0	0.2	1.6	M36	126	67.3
42.0	42.5	1.2	68.2	12.0	0.25	7.0	0.25	2.0	M42		111
48.0	49.0	1.5	75.0	12.0	0.25	7.0	0.25	2.0	M48		123
52.0	53.0	1.5	83.0	14.0	0.25	8.0	0.25	2.0	M52		182
56.0	57.0	1.5	87.0	14.0	0.25	8.0	0.25	2.0	M56		193
60.0	61.0	1.5	91.0	14.0	0.25	8.0	0.25	2.0	M60		203
64.0	65.0	1.5	95.0	14.0	0.25	8.0	0.25	2.0	M64		218

		TD219 Rev. 00	PLANT PURCHASING SPECIFICATION HYDERABAD			HY 101 99 REV. NO. 03 PAGE 1 OF 4
CARBON STEEL BARS (Gr. 15 C8)						
1.0 GENERAL:						
This specification governs the quality of hot rolled/forged Carbon Steel bars of grade 15 C8.						
2.0 APPLICATION :						
For the manufacture of machined parts for general engineering purposes. Bars of dia 100 mm and above may be used for the manufacture of forged components also.						
3.0 CONDITION OF DELIVERY :						
3.1 Bars upto dia / size 100 mm (inclusive) shall be supplied in hot rolled condition.						
3.2 Bars above 100 mm dia / size can be supplied in hot rolled or forged condition.						
3.3 Bars upto 40 mm dia / size can be supplied in as rolled condition if the mechanical properties specified in this specification are achieved.						
3.4 All the bars above 40 mm dia / size shall be supplied in Normalised condition.						
3.5 The bars shall be supplied with ends square and true. The bars shall be supplied in straight lengths.						
4.0 COMPLIANCE WITH NATIONAL STANDARDS:						
This specification complies with						
(1) IS: 1570 (Part II) – 1979] Schedules for Wrought Steels Gr: 15 C 8] Part II Carbon Steels (unalloyed Steels)						
(2) IS: 1875 – 1992 – Carbon steel bars for forgings.						
Revisions: Revised to include carbon steel bars for reforging also.			Issued : STANDARDS ENGINEERING & IPR COORDINATION DEPARTMENT			
Rev.No. 03	Amd. No.	Reaffirmed	Prepared:	Approved:	Dt.of 1st Issue	
Dt. DEC. 2005	Dt.	Year: 2021	Standards	AGM (G)	FEB. 1981	

HY 101 99	PLANT PURCHASING SPECIFICATION HYDERABAD	TD219 Rev. 00	
REV. NO. 03			
PAGE 2 OF 4			
<p>5.0 DIMENSIONS AND TOLERANCES:</p> <p>5.1 Sizes: The bars shall be supplied to the dimensions specified on the order. Unless otherwise specified, Hot rolled bars / rounds shall be supplied in random lengths of 3 to 5 metres. However, the minimum length for Square bars shall be 4 metres.</p> <p>Forged bars shall be supplied in the length of 1.5 to 3.0 meters.</p> <p>5.2 Tolerances:</p> <p>5.2.1 Hot rolled bars / flats: The dimensional tolerances shall be in accordance with Grade I of IS:3739.</p> <p>5.2.2 Forged Bars: + 8 mm on diameter/side width. - 0</p> <p>5.2.3 Straightness: Unless otherwise agreed to, the permissible deviation in straightness shall not exceed 5 mm in any 1000 mm length.</p> <p>5.2.4 The tolerance as per any other international standard are also acceptable with prior written approval of BHEL.</p> <p>6.0 MANUFACTURE:</p> <p>The steel shall be manufactured by the electric furnace, basic oxygen, duplex process or by a combination of these processes. The bars shall be manufactured from Killed steel.</p> <p>Sufficient reduction and discard shall be made from each ingot to ensure freedom from piping, segregation and other harmful defects.</p> <p>7.0 FREEDOM FROM DEFECTS:</p> <p>The bars shall be sound and free from internal and surface defects like cracks, surface flaws and laminations.</p> <p>8.0 HEAT TREATMENT :</p> <p>The bars shall be normalised at a temperature of 880-910°C. The normalizing operation is optional for bars upto dia / size of 40 mm (inclusive).</p>			

	TD219 Rev.00	PLANT PURCHASING SPECIFICATION HYDERABAD	HY 101 99
			REV. NO. 03
			PAGE 3 OF 4

9.0 CHEMICAL COMPOSITION:

9.1 The melt analysis of the material shall be as follows:

Element		C	Mn	Si	S	P
Ladle Analysis	% Min.	0.10	0.60	0.15	-	-
	% Max.	0.20	0.90	0.35	0.030	0.040
Permissible variation in product analysis		± 0.02	± 0.05	± 0.03	+0.005	+0.005

Note: 1. When the steel is aluminium killed or killed with both aluminium and silicon, the requirement of minimum silicon content is not applicable.

9.2 The following elements shall be tested and reported in the test certificate. The limits are specified below.

Ni = 0.30% max. ; Cr = 0.30% max. ; Cu = 0.25% max.
 Mo = 0.15% max. ; B = 0.0003% max. ; V = 0.05% max.
 Sn = 0.05%

Note: (1) $(Cr + Ni + Mo \leq 0.50\%)$
 (2) $(Cu\% + 10 \times Sn\% \leq 0.5\%)$
 (3) Carbon Equivalent = 0.42% max.

10.0 SELECTION OF TEST SAMPLES:

10.1 One sample of each heat shall be analysed for chemical composition.

10.2 One sample from each melt / heat treatment batch / size shall be taken for mechanical testing. Location of the test sample shall be in line with IS 1875.

11.0 MECHANICAL PROPERTIES:

11.1 **Tensile** : When tested in according with IS : 1608, the test pieces shall show the following properties :

Tensile Strength : 410 N/mm², minimum
 Yield strength : 220 N/mm², minimum
 Elongation on
 5.65 $\sqrt{S_0}$ guage length : 25 percent min.

HY 101 99	PLANT PURCHASING SPECIFICATION HYDERABAD	TD219 Rev. 00	
REV. NO. 03			
PAGE 4 OF 4			
<p>11.2 Hardness: 10% of the bars or minimum 10 bars (whichever is more) shall be tested for hardness in accordance with IS 1500 or any other reputed national standard. The hardness shall not be less than 110 BHN.</p> <p>12.0 ULTRASONIC TEST :</p> <p>Each bar above 100 mm dia / side width shall be ultrasonically tested in accordance with AA 085 01 18 to ensure freedom from internal defects. The norms of acceptance shall be as per category 2 of the same.</p> <p>13.0 TEST CERTIFICATES:</p> <p>Three copies of the test certificate bearing the following information shall be furnished.</p> <p>BHEL Order No :</p> <p>BHEL Specification No : HY 10199 Rev. 03</p> <p>Supplier's Name:</p> <p>Cast No :</p> <p>Results of Chemical analysis and Mechanical tests.</p> <p>Results of ultrasonic test (if applicable)</p> <p>14.0 PACKING AND MARKING:</p> <p>Bars shall be supplied in securely packed bundles and shall be suitably protected from corrosion and damage during transit. Bars over 50 mm diameter shall be stamped at one end with cast number, HY10199, and BHEL P.O. for easy identification.</p> <p>Bars of 50 mm diameter and below shall be bundled and a metal lable shall be securely attached to each bundle bearing the following details:</p> <p>HY 10199 Rev. 03 : Hot rolled Carbon Steel bars, Gr:15 C8</p> <p>BHEL Order No:</p> <p>Consignment or Indentification No:</p> <p>Cast No:</p> <p>Size and Weight:</p> <p>Supplier's name:</p>			

	TD219 Rev. 00	PLANT PURCHASING SPECIFICATION HYDERABAD			HY 105 76	
					REV. NO: 03	
					PAGE 1 OF 2	
HIGH HARDNESS, QUENCHED AND TEMPERED STEEL PLATES SUITABLE FOR WELDING						
1.0 GENERAL:						
This specification governs the quality requirements of high hardness, quenched and tempered, alloy / micro-alloy steel plates having high hardness of minimum 370 BHN suitable for welding.						
2.0 APPLICATION:						
For pulverising mills' components which require high abrasion/ wear resistance.						
3.0 CONDITION OF DELIVERY:						
Plates shall be supplied in hot rolled, quenched and tempered condition with minimum hardness of 370 BHN.						
4.0 COMPLIANCE WITH STANDARDS:						
There is no National or International standard which meets the requirement of this standard.						
4.1 Equivalent grades: Hardox 400, XAR 400, Dillidur 400V etc. are equivalent grades.						
5.0 DIMENSIONS AND TOLERANCES:						
5.1 Dimensions: The dimensions shall be as specified in the order.						
5.2 Tolerances: The tolerance shall be as per ASTM A6 (the latest).						
6.0 MANUFACTURE:						
The steel shall be manufactured in open-hearth or basic electric furnace or by basic oxygen process. Any other method of manufacture of steel is acceptable subject to mutual agreement with the manufacturer.						
The steel shall be fully killed.						
7.0 CHEMICAL COMPOSITION:						
7.1 Chemical composition is left to the discretion of the manufacturer. However, complete chemical composition of the melt shall be reported in the test certificate.						
7.2 Carbon Equivalent, CE (%):						
a. For plates thickness upto 20mm (inclusive) = 0.46max.						
b. For plates above 20 - 32 mm (inclusive) thickness= 0.56max.						
c. For plates above 32mm, CE values shall be mutually agreed with BHEL						
The actual values of CE shall be reported in the test certificate.						
Revisions: Revised Cl. 7.2 & Cl.11.0				Issued : STANDARDS ENGINEERING & IPR COORDINATION DEPARTMENT		
Rev.No. 03	Amd No.	Reaffirmed	Prepared: ENGINEER, MATLS.ENGG.	Approved: Sr. DGM (TS)	Date of 1st Issue: SEP., 1989	
Dt. SEP. 2014	Dt.	Year: 2021				

HY 105 76	PLANT PURCHASING SPECIFICATION HYDERABAD	TD219 Rev. 00	
REV. NO. 03			
PAGE 2 OF 2			

8.0 FREEDOM FROM DEFECTS:

The plates shall be free from cracks, scabs, laminations and other harmful defects.

9.0 HEAT TREATMENT:

Suitable heat treatment (quenching and tempering) cycle shall be selected to achieve the hardness. The same shall be reported in the test certificate.

10.0 MECHANICAL PROPERTIES (Hardness):

The plates shall conform to the minimum hardness of 370 BHN. Each plate shall be tested for hardness and the hardness values shall be reported in the test certificate.

11.0 WELDING CHARACTERISTICS:

11.1 Carbon equivalent (CE) shall be as per Cl. 7.2 of this specification.

11.2 The suppliers shall furnish the bending details and full welding details including electrode composition (Brand & Make) preheating temperature, PWHT (if req.), etc. for each size of the plate offered, along with technical offer. These details will be reviewed by BHEL for its suitability.

12.0 TEST CERTIFICATES:

Five copies of the test certificate with the following details shall be furnished.

- a) BHEL Order No.
- b) HY10576 Rev.03
- c) Name of the Mill
- d) Size & Weight
- e) Heat No.
- f) Heat treatment details
- g) Results of chemical analysis
- h) Results of hardness test on each plate.

13.0 MARKING:

Each plate shall be identified (hard punched/ stenciled) with the following details:

- a) BHEL Order No.
- b) HY10576 Rev. 03
- c) Heat/Melt No.
- d) Supplier's name & trade mark

14.0 REJECTION AND REPLACEMENT:

In the event of any plate proving defective during the course of further processing or testing, such material shall be rejected and the supplier shall make immediate arrangements to replace the same at free of cost.

(For Internal Use Only)
Document No.: E&D: 330
Rev. No.: 00
Date of Revision: 04.07.2019
Issue no: 01

WELDING & PAINTING PROCEDURE

BHARAT HEAVY ELECTRICALS LIMITED
FSIP, JAGDISHPUR
AMETHI -227817

Controlled
Copy No. 01
Copy No.:
Issue to: UNIT INTRANET PORTAL
Date of Issue: 04.07.2019
Issued by: Engineering

Distribution list of **Welding Procedure E&D: 330, Rev. No. 00, Date of Rev. 04.07.2019 Issue No: 01**

Controlled Copy No.

Copy Distributed to

Master Copy

Functional Chief (Engineering)

01

Unit Intranet Portal

BHARAT HEAVY ELECTRICALS LIMITED
FSIP, JAGDISHPUR

WELDING & PAINTING PROCEDURE

Document No.: E&D: 330
Section No.: 01
Section Rev. No.: 00
Section Rev. Date: 04.07.19
Issue No: 01
Page 1 of 1

1.0 TABLE OF CONTENTS

Section No.	Description	Section Rev. No.	Section Rev. Date
01	Table of Contents	00	04.07.19
02	Record of Revisions	00	04.07.19
03	Distribution List	00	04.07.19
04	Welding Procedure	00	04.07.19
05	Painting Procedure	00	04.07.19

Prepared By

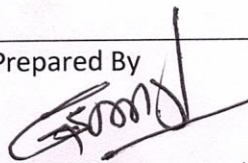

Functional Chief (Engineering)

Approved By



HOD (Engineering)

BHARAT HEAVY ELECTRICALS LIMITED
FSIP, JAGDISHPUR

WELDING & PAINTING PROCEDURE

Document No.: E&D: 330
Section No.: 02
Section Rev. No.: 00
Section Rev. Date: 04.07.19
Issue No: 01
Page 1 of 1

2.0 RECORD OF REVISIONS

Revision Date	Section No.	Revision No.	Clause No.	Nature of Changes
04.07.19	All	00	--	Updation in line with merger of CS-FP & IP

Prepared By

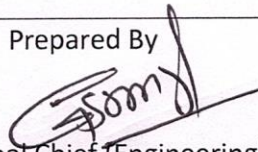

Functional Chief (Engineering)

Approved By



HOD (Engineering)

BHARAT HEAVY ELECTRICALS LIMITED
FSIP, JAGDISHPUR

WELDING & PAINTING PROCEDURE

Document No.: E&D: 330
Section No.: 03
Section Rev. No.: 00
Section Rev. Date: 04.07.19
Issue No: 01
Page 1 of 1

3.0 DISTRIBUTION LIST

MASTER COPY: Functional Chief (Engineering)

COPY 01: Unit Intranet Portal

Prepared By

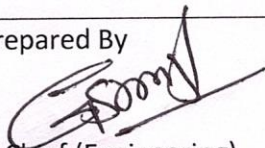

Functional Chief (Engineering)

Approved By



HOD (Engineering)

BHARAT HEAVY ELECTRICALS LIMITED
FSIP, JAGDISHPUR

WELDING & PAINTING PROCEDURE

Document No.: E&D: 330
Section No.: 04
Section Rev. No.: 00
Section Rev. Date: 04.07.19
Issue No: 01
Page 1 of 2

4.1 WELDING PROCEDURE:

4.1.1 The welding procedure outlined will be followed to ensure uniform and good quality welding.

4.1.2 The welding must be Arc / Flux cored after maintaining proper fit up.

4.1.3 The material specification of welding electrodes/Flux core wire to be as below:

A **Electrode: MS** - E 6013

Arc welding (2.5 mm , 3.15 mm or 4.0 mm):- make

Advani- Oerlikon: Overcords	D&H : Medio	Rockwell: V-117	I.O.L/ESAB: Vordian/Ferrospeed plus
--------------------------------	----------------	--------------------	---

Electrode: SS - E 7018

Arc welding (2.5 mm , 3.15 mm or 4.0 mm) : - make

Advani-Oerlikon: Supercito	D & H : Supra Therme	ESAB: Ferro Weld-2 / ESAB 36 H
-------------------------------	-------------------------	-----------------------------------

B MIG WELDING:- (Flux core wire 1.6 mm or 1.8 mm)

Solid wire core for MS -- ER 70S-6

For SS-- ER-308 L /ER309 L

Make- Ador /D&H/Esab/D&H Sechron/Cotmac

4.1.3 Edges to be prepared as per following sketch:

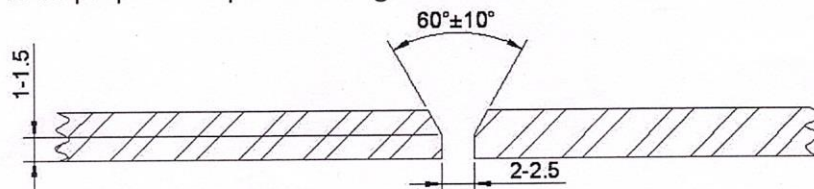

4.1.4 Root pass welding to be carried out buy using 2.5 mm welding electrodes ,further filling may be done either by 3.15 mm or 4.0 mm electrodes/Root pass welding to be carried out by 1.2 mm to 1.8 mm dia flux core wire ,further filling by 1.2 mm to 1.8 mm flux core wire.

4.1.5 Ensure root weld is uniform and penetration is proper.

4.1.6 Between two passes, remove slag and clean weld surfaces.

Prepared By

[Signature]

Functional Chief (Engineering)

Approved By

[Signature]

HOD (Engineering)

BHARAT HEAVY ELECTRICALS LIMITED
FSIP, JAGDISHPUR

WELDING & PAINTING PROCEDURE

Document No.: E&D: 330
Section No.: 04
Section Rev. No.: 00
Section Rev. Date: 04.07.19
Issue No: 01
Page 2 of 2

4.1.7 In case of undercut grind the weld surface smooth and fill up with 2.5 mm welding electrode/wire core.

4.1.8 Employ down hand method for welding.

4.2 CHECK POINTS:

Audit checks are conducted for the quality of welding of every cerialin item. The Die Penetration test is to be carried as per E&D:331 after each root pass.

The visual examination of welding is to be carried out as per detail below:

1. The weld shall be free of cracks.
2. The face of weld shall be flush with the surface of base metal & weld shall merge smoothly with base metal. Undercut shall not exceed 1 mm & welding reinforcement shall not exceed 3 mm.
3. The root of weld shall be inspected & there shall be no evidence of cracks, incomplete fusion or inadequate joint penetration.
4. The weld shall be free from overlap.
5. The weld shall be free from accumulated slag the sum of the greatest dimensions of which shall not exceed 6 mm.
6. Grinding is not allowed on weld bead.
7. Grinding of all gas cut portion to be ensured (including lifting lug)

4.3 Welder Qualification: Welder qualification test to be done strictly for each welder as per AWS D-1.1 by a third party NABL accredited lab once in a year.

Prepared By

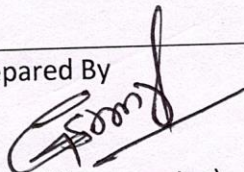

Functional Chief (Engineering)

Approved By



HOD (Engineering)

BHARAT HEAVY ELECTRICALS LIMITED
FSIP, JAGDISHPUR

WELDING & PAINTING PROCEDURE

Document No.: E&D: 330
Section No.: 05
Section Rev. No.: 00
Section Rev. Date: 04.07.19
Issue No: 01
Page 1 of 2

5. PAINTING PROCEDURE:

5.1. This procedure covers the requirements of primer and Final paint for M. S. Casing for in-land applications/costal region/export

5.2. This procedure specifies the painting requirements to provide adequate surface protection.

5.3. SPECIFICATION OF PRIMER/PAINT:-

Type of paint	Specification	Make
Alkyd Red Oxide Zinc Phosphate Primer	As per IS:12744 –DFT 30 Mic /coat	Berger ,Asian Paint , Dulux
General Purpose Aluminium Paint	As per IS:2339-DFT 30 mic/coat	Berger ,Asian Paint , Dulux
For costal region /Export / Special items ,paint type to be specified by the customer	As per specification provided by the customer	Berger ,Asian Paint , Dulux

SURFACE PREPARATION:-

5.3.1. Surface of component shall be thoroughly cleaned before the application of primer paint by either Power Tool cleaning (SSPC-SP3) or Abrasive Blast cleaning. The surface shall be free from dust, rust, weld, slag, spatters, oil, grease etc.

5.4. APPLICATION OF PAINT:-

5.4.1. Surface prepared as mentioned above shall be applied with one coat of Alkyd Red Oxide Zinc Phosphate primer (as per IS:12744) where no special primer is mentioned for M.S. Casing.

Prepared By

Functional Chief (Engineering)

Approved By

D2 Chauhan
HOD (Engineering)

BHARAT HEAVY ELECTRICALS LIMITED
FSIP, JAGDISHPUR

WELDING & PAINTING PROCEDURE

Document No.: E&D: 330
Section No.: 05
Section Rev. No.: 00
Section Rev. Date: 04.07.19
Issue No: 01
Page 2 of 2

5.5. GENERAL:-

- 5.5.1. Paint make Berger /Dulux / Asian shall be used as supplied by the supplier without any addition of thinner.
- 5.5.2. Primer shall be thoroughly stirred before application. Primer can either be applied on surface by brushing or spraying using compressed air uniformly. The thickness of the primer shall not be less than 30 microns/coat (where no other specifications are mentioned).
- 5.5.3. Adequate drying time is to be allowed after each coat before next coat of paint.
- 5.5.4. No painting is required in case of Stainless Steel components, unless otherwise specified.
- 5.5.5. For all machined components, rust preventive fluids shall be used (where no other specifications are mentioned).
- 5.5.6. Rusting of received material at BHEL IP will be treated as use of poor paint / process and the same will be out rightly rejected or repainting will be done on the risk and cost of supplier on the discretion of BHEL.

5.6. Inspection:-

- 5.6.1. Surface preparation, primer coating shall be checked at appropriate stages by executing agency before proceeding to next operation.

Prepared By

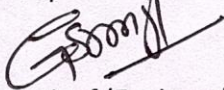

Functional Chief (Engineering)

Approved By

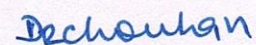

HOD (Engineering)

(For internal use only)

Doc. No. E&D: 331

Rev. No.: 00

Date of revision: 04.07.2019

DYE PENETRATION TEST PROCEDURE

BHEL FSIP JAGDISHPUR

AMETHI-227817

COPY NO:

Controlled

Copy No...01.....

ISSUED TO: UNIT INTRANET PORTAL

DATE OF ISSUE: 04.07.19

ISSUED BY: E&D

BHARAT HEAVY ELECTRICALS LIMITED FSIP, JAGDISHPUR DYE PENETRATION TEST PROCEDURE	Document No. : E&D: 331 Section No. : 01 Section Rev. No.: 00 Section Rev. Date: 04.07.19 Page 1 of 1
--	---

1.0 TABLE OF CONTENTS:

Section No.	Description	Sec. Rev. No.	Sec. Rev. Date	No. of Pages
01	Table of Contents	00	04.07.19	1
02	Record of revision	00	04.07.19	1
03	Distribution List	00	04.07.19	1
04	Dye Penetration Test Procedure	00	04.07.19	3

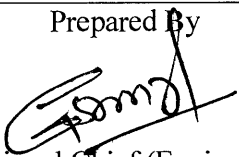
Prepared By  Functional Chief (Engineering)	Approved By D2chouhan HOD (Engineering)
--	---

BHARAT HEAVY ELECTRICALS LIMITED FSIP, JAGDISHPUR DYE PENETRATION TEST PROCEDURE	Document No. : E&D: 331 Section No. : 02 Section Rev. No. : 00 Date of Rev : 04.07.19 Page 1 of 1
--	---

2.0 Record of revision

Date	Revision No.	Section Revised	Revision
04.07.19	00	All	Updated in accordance with the merger of CS-FP & IP

Prepared By

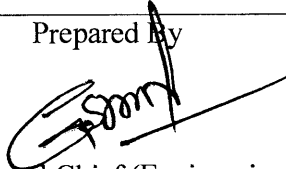
 Functional Chief (Engineering)

Approved By





HOD (Engineering)

BHARAT HEAVY ELECTRICALS LIMITED FSIP, JAGDISHPUR	Document No. : E&D: 331 Section No. : 03 Section Rev. No.: 00 Date of Rev : 04.07.19 Page 1 of 1
DYE PENETRATION TEST PROCEDURE	

3.0 Distribution List:

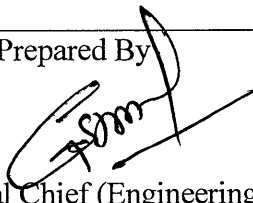
Control Copy No.	Issued To
Master Copy	Functional Chief (Engineering)
01	Unit Intranet Portal

Prepared By	Approved By
 Functional Chief (Engineering)	 HOD (Engineering)

BHARAT HEAVY ELECTRICALS LIMITED FSIP, JAGDISHPUR DYE PENETRATION TEST PROCEDURE	Document No. : E&D: 331 Section No. : 04 Section Rev. No.: 00 Date of Rev. : 04.07.19 Page : 1 of 3
--	---

1.0 Scope:

This procedure shall be used for colour contrast (visible dye) method of liquid penetrant examination of materials for detecting discontinuities in welded joints of MS casings/ rings/ Cones.

2.0 METHOD AND MATERIALS:

A visible dye penetrant which can be easily seen in natural light or in artificial light shall be used (Solvent removable penetrant and Non Aqueous suspended type developer) •

3.0 SURFACE PREPARATION:

3.1 In general, satisfactory results may be obtained in the as welded, as forged, as cast and as rolled condition. Machining and grinding may be required when surface irregularities would otherwise mask the indications of unacceptable discontinuities.

3.2 Prior to penetrant examination the surface shall be carefully examined. Surface shall be free from dirt, grease, lint, scale, welding flux, spatters or any extraneous matter which may be tend to cover. Surface openings or otherwise interfere with proper evaluation of test result.

3.2.1 Adjacent areas to a minimum length of 25mm on either side of the weld shall be prepared as specified in 3.2.

3.2.2 Surfaces shall be thoroughly cleaned using acetone before applying penetrant.

3.2.3 Surface shall be dried at least 3 minutes prior to Application of Penetrant.

4.0 PENETRATION APPLICATION

4.1 The penetrant shall be applied by dipping, brushing or spraying. If the penetrant is applied by spraying, using compressed air. type apparatus, a filter shall be placed at the air inlet to preclude contamination of penetrant by oil, water or dirt that might have collected in the air lines.

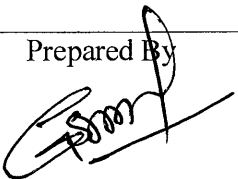
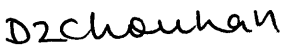
Prepared By  Functional Chief (Engineering)	Approved By  HOD (Engineering)
--	---

BHARAT HEAVY ELECTRICALS LIMITED FSIP, JAGDISHPUR	Document No. : E&D: 331 Section No. : 04 Section Rev. No.: 00 Date of Rev. : 04.07.19 Page : 2 of 3
DYE PENETRATION TEST PROCEDURE	

- 4.2 The temperature of the penetrant and the surface of the part to be processed shall not be below 16°C nor above 52°C throughout the examination period.
- 4.3 Minimum penetration time shall be 15 minutes.

5.0 EXCESS PENETRANT REMOVAL:

- 5.1 After the penetrant time specified above in column 4.3 has elapsed any penetrant remaining on the surface shall be removed, taking care to minimize removal of penetrant from the discontinuities.
- 5.2 Penetrant shall be removed by wiping with a clean lint free dry cloth. The operation should be repeated until most traces of penetrants are removed. A clean dry cloth moist with solvent (cleaner) shall then be used to wipe the surface lightly. Extreme care shall be taken to prevent over cleaning as over cleaning can and does remove penetrant from discontinuities. Under no circumstances cotton waste shall be used for removing penetrant.

6.0 DEVELOPER APPLICATION:

- 6.1 After cleaning, developer shall be applied by spraying, prior to applying the developer it must be thoroughly agitated to ensure adequate dispersion of the suspended particles. A uniform thin coating of developer must be applied. Conversely avoid the formation of parts of developer in the cavities since heavy coatings may mask indication.
- 6.2 Allow 5 minutes for the developer to dry before the start of inspection and a maximum of 30 minutes to complete the interpretation of results of the examination.

7.0 EVALUATION OF INDICATION:

- 7.1 Discontinuities open to the surface will be indicated by the bleeding out of the penetrant. Localized surface imperfection which occur from machining marks, or surface irregularities shall be ignored as non-relevant indication.
- 7.1.1 Non—relevant indication and broad areas of pigmentation, which would mask indication of defects, shall be reprocessed and retested.
- 7.2 Relevant indications are those, which result from discontinuities open to surfaces. Linear indications are those indications in which the length is more than three times the width. Rounded indications are circular or elliptical with length lesser than three times the width.

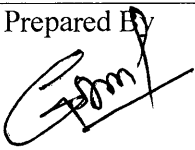
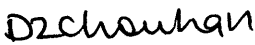
Prepared By 	Approved By 
Functional Chief (Engineering)	HOD (Engineering)

BHARAT HEAVY ELECTRICALS LIMITED FSIP, JAGDISHPUR DYE PENETRATION TEST PROCEDURE	Document No. : E&D: 331 Section No. : 04 Section Rev. No.: 00 Date of Rev. : 04.07.19 Page : 3 of 3
--	---

8.0 ACCEPTANCE CRITERIA:

No cracks are permitted on any surface.



8.1 WELDS :

8.1.1 The following indications are not acceptable:

- a) Only indications with major dimensions greater than 1.6mm shall be considered as relevant.
- b) Unless otherwise specified the following relevant indications are unacceptable:
 1. Any cracks or linear indications.
 2. Rounded indications with dimensions greater than 4.8mm.
 3. Four or more rounded indications in a line separated by 1.6mm or less edge to edge.
 4. Ten or more rounded indications in any 3870 Sq. mm (6 Sq. in) of surface with the major dimension of this area not to exceed 152 Sq. mm with the area taken in the most unfavourable location relative to the indications being evaluated.

9.0 POST EXAMINATION CLEANING:

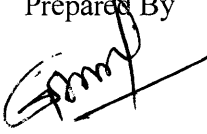
9.1 As soon as practical, after completion of the penetrant examination the completed parts shall be cleaned to remove residual penetrants materials.

Prepared By  Functional Chief (Engineering)	Approved By  HOD (Engineering)
--	---

SL. NO	COMPONENT	CHARACTERISTICS & OPERATIONS	CLASS	TYPE OF CHECK	QUANTUM OF CHECK		REFERENCE DOCUMENT#	ACCEPTANCE NORMS	FORMAT OF RECORD	AGENCY		REMARKS
					M	C				M	C	
1.	2.	3.	4.	5.	6.		7.	8.	9.	10.		11.
1.0	Steel Plates for Casing & Rings	a) Chemical Composition	Maj.	Chemical	1sample/lot	1sample/lot	IS:2062 (Gr.A)	IS:2062 (Gr.A)	MTC / Test Report	P	V	Correlated test certificate and inspection reports to be maintained by Vendor. Mechanical test shall be witnessed by BHEL in case material purchased & used without correlated MTC.
		b) Mechanical Properties	Maj.	Mechanical	-do-	-do-	IS:2062 (Gr.A)	IS:2062 (Gr.A)	MTC / Test Report	P	V	
2.0	Fabricated Casing	a) Suitability of welding procedure Specification	Maj.	Procedure qualification test	Once	Once	E&D:330 Section 04	E&D:330 Section 04	Welding procedure & Qualification record	P	W	Qualification test of welder done at BHEL's/ Vendor's work may be witnessed by BHEL. Records shall be maintained.
		b) Capability of welder in adopting welding procedure	Maj.	Procedure qualification test	Periodically once in one year for each welder	Periodically once in one year for each welder	E&D:330 Section 04	E&D:330 Section 04	Qualification certificate	P	W	

LEGEND:

M: MANUFACTURER C: BHEL, P: PERFORM W: WITNESS AND V: VERIFICATION (AS APPROPRIATE) CHP: BHEL SHALL IDENTIFY IN COLUMN "C" AS "W".

Note:# BHEL Inspection Engineer to check, approval date/ revision no. of reference documents at the time of Inspection

SL. NO	COMPONENT	CHARACTERISTICS & OPERATIONS	CLASS	TYPE OF CHECK	QUANTUM OF CHECK		REFERENCE DOCUMENT#	ACCEPTANCE NORMS	FORMAT OF RECORD	AGENCY		REMARKS
					M	C				M	C	
1.	2.	3.	4.	5.	6.		7.	8.	9.	10.		11.
2.0	Fabricated Casing (Cont.)	c) Welding i) Fit up ii) Root run d) Liquid penetrate inspection for weld joints i) Butt Joint ii) Fillet Joint e) Welding Quality & Finished f) Dimension g) Painting	Maj. Maj. Maj. Maj. Maj.	Visual Visual NDT Visual Physical Physical	100% 100% 100% 10% 100% 100%	10% 10% 10%	Drawing Drawing E&D:331 Section 04 E&D:330 Section 04 Drawing E&D:330 Section 05	Drawing Drawing E&D:331 Section 04 E&D:330 Section 04 Drawing E&D:330 Section 05	Inspection Report QAC 4301 & 4302 Inspection Report Inspection Report Inspection Report QAC 4306 Inspection Report QAC 4307	P P P P P	V V W W W	BHEL shall verify the record at sub-contractor works and carryout the check on min 10% of samples selected at random for the test. If any sample fails, 100% of the lot shall be checked. The evaluation of LPI of welded joints is to be carried out by persons having min ASNT Level-II Qualification. Welder's identification shall be recorded.
3.0	Documentation	Review & Record of Inspection Reports	Maj.	Review of document	100%	100%	As Above	-	As Above	P	V	
4.0	Quality Requirement	Complete quality requirement	Maj.	Review of document	100%	-	QR/20-21 Rev00	-	-	P	-	BHEL inspector may seek records for compliance of its quality requirement document.

LEGEND:

M: MANUFACTURER C: BHEL, P: PERFORM W: WITNESS AND V: VERIFICATION (AS APPROPRIATE) CHP: BHEL SHALL IDENTIFY IN COLUMN "C" AS "W".

Note:# BHEL Inspection Engineer to check, approval date/ revision no. of reference documents at the time of Inspection



FSIP - JAGDISHPUR

INSPECTION REPORT OF CASING FOR P.F. BEND/FIE/MOE

Format No. : QAC: 4301

SUPPLIER _____ DRAWING NO.: _____
 P.O.No.: _____

CONTRACT No. _____ ITEM: _____
 DATE OF INSPECTION: _____

ANGLE	BEND NO.	I.D.		O.D.		AXIAL SHIFT		RADIAL SHIFT							OUT OF SQUARENESS				DP TEST							
		AHS	TES	AHS	TES	1	2	INNER				OUTER			A		B									
								1	2	3	4	5	6	7	1	2	3	4	5	6	7	1	2	1	2	

Dimension of Segment and bend					Type of Flange	
as per drawing		Actual				
X =						
Y =						
OAL =						
IAL =						
C1 =						
C2 =						
C3 =						

Pattern No. : _____
 Plate Thickness : _____
 Welder Name : _____

Radius : _____
 VAR No. : _____
 Style No.: _____
 ITEM No. : _____

Inspected By : _____ **Approved By:** _____
 Inspection Remarks by BHEL Representative : _____



FSIP-JAGDISHPUR

CHECK SHEET FOR FINAL INSPECTION OF
CASING FOR PF BEND/FIE/MOE

Format No: QAC: 4306 Rev.00

ITEM:	DRAWING NO.:
P.O. NO.:	DATE OF INSPECTION:
P.O. DATE:	SUPPLIER:

Sl. No.	Pattern No.	Angle (Θ)	C2	OAL	IAL	Flange O.D.		Flange I.D.		Welding	Lug Position	Painting
						AHS	TES	AHS	TES			
1												
2												
3												
4												
5												
6												
7												
8												
9												
10												

Remarks:

Inspected By:

Approved By:



PAINTING CERTIFICATE

FORMAT NO. QAC :4307

FSIP-JAGDISHPUR

SUPPLIER :-

ITEM :-

DATE OF INSPECTION :-

P.O. NO.:-

DRAWING NO.:-

Painting reference No.:-

SI. No.	PATTERN NO	PARTY IDENTIFICATION MARK	PROPER SURFACE PREPARATION	VISUAL PAINTING	Required Minimum DFT	OBSERVED DFT

This is certified that the above MS casing are painted as per related painting scheme / Zinc Chrome Red oxide Alkyl Primer confirming to IS – 2074 and as per CE -0265.20.

INSPECTED BY:

REVIEWED BY:

INSPECTION REMARK BY BHEL REPRESENTATIVE

QUALITY REQUIREMENTS

Following quality requirement is for the suppliers of M.S. Casings of BHEL FSIP, Jagdishpur. Each supplier participating in Rate Contract shall go through the Terms & Condition of this document thoroughly and participate in RC as per their facilities and 'Process Maturity' in line with this document. Supplier may has to submit documentary proof/present physically of all requirements as and when required by BHEL.

A. RAW Material

1. M.S.Sheet:-

- As per BHEL Drawing
- Receipt and Issue of material used for BHEL supply shall be maintained as per enclosed Annex-A
- Correlated test certificate of material will be required along with each dispatch of M.S Casing.

2. Welding Electrode:-

- As per latest revision of document no. E&D 330 section 04.
- Photocopy of invoices of procurement of welding rod/flux core wire may be asked by BHEL against its PO to ensure type/make & quality of electrode used.

3. Paint:-

- As per latest revision of document no. E&D 330 section 05.
- Any other painting requirement will be indicated in drawing /painting scheme. It will be provided by BHEL separately with PO.
- Photocopy of invoices of procurement of paint may be asked by BHEL against their PO to ensure quality & make of paint used.

B. Fabrication/In-Process

1. Fabrication of M.S.Casing:

- As per BHEL Document E&D 306 (Latest revision) and BHEL Drawing.
- Proper fit-up is to be maintained as below:

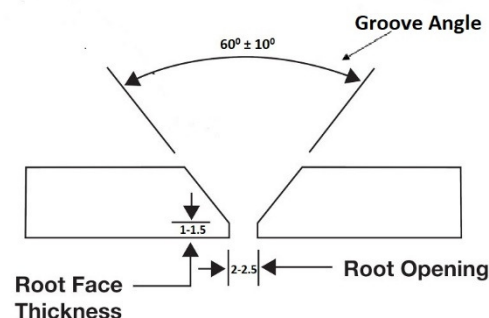

2. Welder Qualification:

- Once in every Year for each welder to be done strictly as per AWS D-1.1 by a third party NABL Accredited Lab. On lack of valid welder qualification certificate Casing manufacturing may be hold by BHEL until submission of the same. BHEL may witness welder qualification.

3. Welding/Hard facing: (Strictly as per E&D: 330)

- Proper Penetration Required
- No Grinding on Weld bead allowed
- Grinding of all gas cut portion to be ensured (including lifting lug)

4. Machining:

- Surface roughness of 6.3 micron or as specified in drawing to be achieved at complete machining portion.
- **Grinding/welding is strictly prohibited on machined portion.**

5. Painting: As per BHEL Document E&D: 330 (Latest revision) & BHEL Drawing

- Power Tool cleaning (SSPC-SP3) or Abrasive Blast cleaning for removal of dust, rust, weld, slag, spatters, oil, grease etc. before painting is must.
- No thinner to be added in paint.
- Rusting of received material at BHEL FSIP will be treated as use of poor paint/process and the same will be out rightly rejected or Repainting will be done on the risk and Cost of supplier on the discretion of BHEL.
- Any other painting requirement will be indicated in drawing / painting scheme. It will be provided by BHEL separately.

C. Instruments for Inspection

1. Duly spirit leveled surface plate
2. One meter Right Angle (Tri square)
3. 01 meter height gauge
4. 02 nos. Vernier Caliper, Range (0-1000 mm & 0-300 mm)
5. 02 nos. Measuring Tape, Range (0-3000mm & 0-5000mm)
6. Ultrasonic wall thickness gauge (i.e. D' meter)
7. Digital Coating thickness gauge for checking thickness of paint
8. Feeler gauge, spirit level, 01 meter scale, Plumb Bob
9. Proper Materials Handling / movement, instrument like as overhead crane/ Hydra etc
10. Digital Surface roughness gauge for checking the roughness of machined parts.
11. Hardness tester for checking the hardness of hard facing
12. Any kind of other instrument as per requirement of BHEL shall be arranged by the supplier

All above Instrument's Calibration should be traceable to NABL/BHEL approved Lab. BHEL reserves the right to stop inspection in case of unavailability of above instruments.

D. BHEL Inspection/Audit

1. Inspection call shall be raised by the vendor at least 1-2 days in advance by email to BHEL QC with a copy to MM having specific call number & details of items offered for inspection i.e. name of item as per PO, drawings number, variant number, stage of inspection, PO number, quantity offered, proposed date of inspection etc.
2. Call will be raised along with its dimension report actually measured and fill by vendor's QC/production at the required format of inspection. Each inspection call will have following disclaimer in the email:
"Material is ready for inspection as per above schedule. However, only positive variation in Quantity may be there. All the calibrated Measuring instruments are available with us for the above inspection. We have ensured that casing is fabricated as per BHEL specifications. [I.e. material conforms IS: 2062 Grade A (Latest Revision). Fabrication is done strictly as per E&D: 306 and welding is carried out as per E&D: 330]. The above lot offered to you is already checked at our end and found acceptable."
3. **No items shall be dispatched without clearance by BHEL.**
4. BHEL Authorized representative/ Inspectors will have right of inspection/Audit/Photography of BHEL product at any supplier's premises without prior notice. Documentary evidence of compliance of above quality requirement shall be maintained by vendor and may be verified by BHEL.
5. In case of violation of quality requirements, BHEL Reserves the right to out rightly reject/ Hold for Rectification/Rectify at risk and cost of Supplier. BHEL also reserves the right to cancel the Purchase order or perform Risk Purchase.
6. **PDI/inspection done by BHEL at vendor's does not absolve vendor of their responsibility to supply a quality product as per specification/drawings etc. Vendor has to rectify / replace the casing if the casing is not manufactured as per drawing & discrepancy observed later after receipt at BHEL's work or at BHEL's customer site.**

Annexure-A

Vendor Name and address

Ref No.....

Date: _ / _ / _

**M/s. BHARAT HEAVY ELECTRICALS LIMITED
 FABRICATION, STAMPING & INSULATOR PLANT
 JAGDISHPUR INDUSTRIAL AREA, DISTT. AMETHI U.P.227817**

Kind Attention-

Invoice No. –

Invoice Date -

Sub: Material used against BHEL Purchase Order No. Dated.....

Dear Sir,

With reference to above order, we are submitting our material test certificate for following material used in manufacturing of M.S. casing.

Sl. No.	Plate Thickness	Test Certificate No.	Opening Balance	Material Consumption	Closing Balance

Authorised Signatory