

प्रथम कोण प्रक्षेपण/FIRST ANGLE PROJECTION

सभी विमाएँ मिलीमीटर में हैं।/ALL DIMENSIONS ARE IN mm.

पृष्ठ संख्या 44 (बी)/FORM 44 (B)

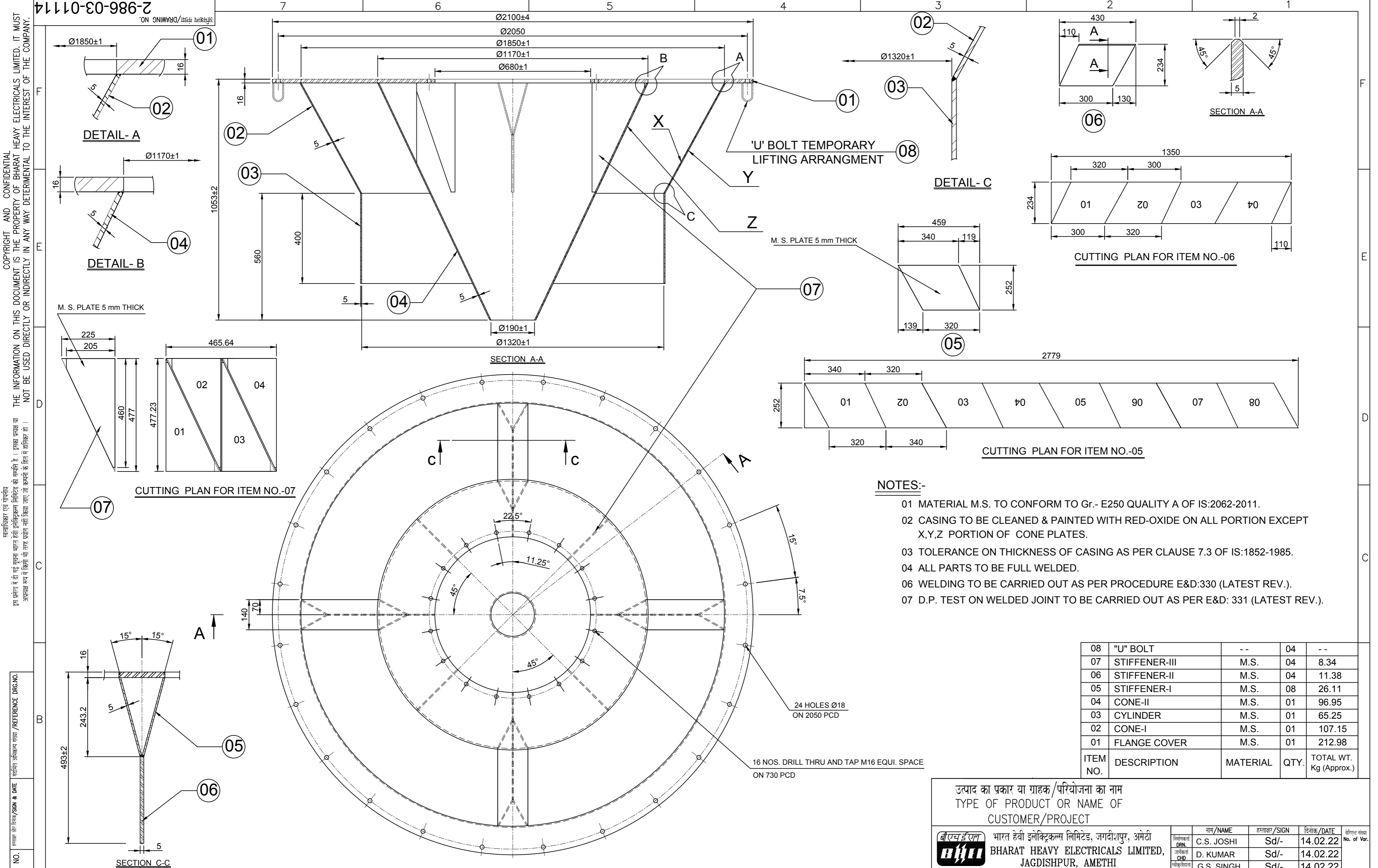

NOTES:-

- 01 MATERIAL M.S. TO CONFORM TO Gr.- E250 QUALITY A OF IS:2062-2011.
- 02 CASING TO BE CLEANED & PAINTED WITH RED-OXIDE ON ALL PORTION EXCEPT X,Y,Z PORTION OF CONE PLATES.
- 03 TOLERANCE ON THICKNESS OF CASING AS PER CLAUSE 7.3 OF IS:1852-1985.
- 04 ALL PARTS TO BE FULL WELDED.
- 06 WELDING TO BE CARRIED OUT AS PER PROCEDURE E&D:330 (LATEST REV.).
- 07 D.P. TEST ON WELDED JOINT TO BE CARRIED OUT AS PER E&D: 331 (LATEST REV.).

ITEM NO.	DESCRIPTION	MATERIAL	QTY.	TOTAL WT. Kg (Approx.)
08	"U" BOLT	--	04	--
07	STIFFENER-III	M.S.	04	8.34
06	STIFFENER-II	M.S.	04	11.38
05	STIFFENER-I	M.S.	08	26.11
04	CONE-II	M.S.	01	96.95
03	CYLINDER	M.S.	01	65.25
02	CONE-I	M.S.	01	107.15
01	FLANGE COVER	M.S.	01	212.98

उत्पाद का प्रकार या ग्राहक/परियोजना का नाम
TYPE OF PRODUCT OR NAME OF CUSTOMER/PROJECT

भारत हेवी इलेक्ट्रिकल्स लिमिटेड, जगदीशपुर, अमेठी
BHARAT HEAVY ELECTRICALS LIMITED, JAGDISHPUR, AMETHI

नाम/NAME	हस्ताक्षर/SIGN	दिनांक/DATE	संशोधन संख्या/No. of Var.
C.S. JOSHI	Sd/-	14.02.22	
D. KUMAR	Sd/-	14.02.22	
G.S. SINGH	Sd/-	14.02.22	

विभाग/DEPTT. E&D
कोड/CODE 400

पैमाना/SCALE N.T.S.

भार कि.गा. WEIGHT (KG) 528.20 Kg (Approx.)

असेम्बली अभिकल्प का संदर्भ REFER TO ASSLY. DRG.

नाम क्रमांक/ITEM NO.

शीर्षक/TITLE
M.S. CASING FOR OUT LET VENTURI

कार्ड कोड/ CARD CODE

अभिकल्प संख्या/DRAWING NO.
2-986-03-01114

पृष्ठ संख्या/Sheets No. 22
पृष्ठों की संख्या/No. of Sheets 23 24

COPYRIGHT AND CONFIDENTIAL
 THE INFORMATION ON THIS DOCUMENT IS THE PROPERTY OF BHARAT HEAVY ELECTRICALS LIMITED. IT MUST NOT BE USED DIRECTLY OR INDIRECTLY IN ANY WAY DETERIMENTAL TO THE INTEREST OF THE COMPANY.
 संपूर्ण सूची संख्या/INVENTORY NO.
 संशोधन और दिनांक/REV. & DATE
 संशोधन और दिनांक/REV. & DATE
 संशोधन और दिनांक/REV. & DATE

INVENTORY NO. SIGN. AND DATE REF. DRG. NO. COMPUTER FILE NAME 26250268 DRG. THE INFORMATION ON THIS DOCUMENT IS THE PROPERTY OF BHARAT HEAVY ELECTRICALS LIMITED. IT MUST NOT BE USED DIRECTLY OR INDIRECTLY IN ANY WAY DETRIMENTAL TO THE INTEREST OF THE COMPANY

DRG. NO. 2-62-309-50268

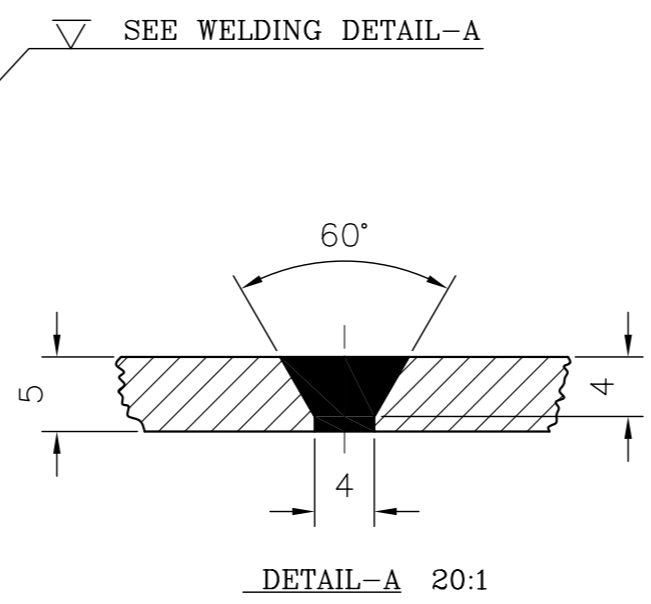
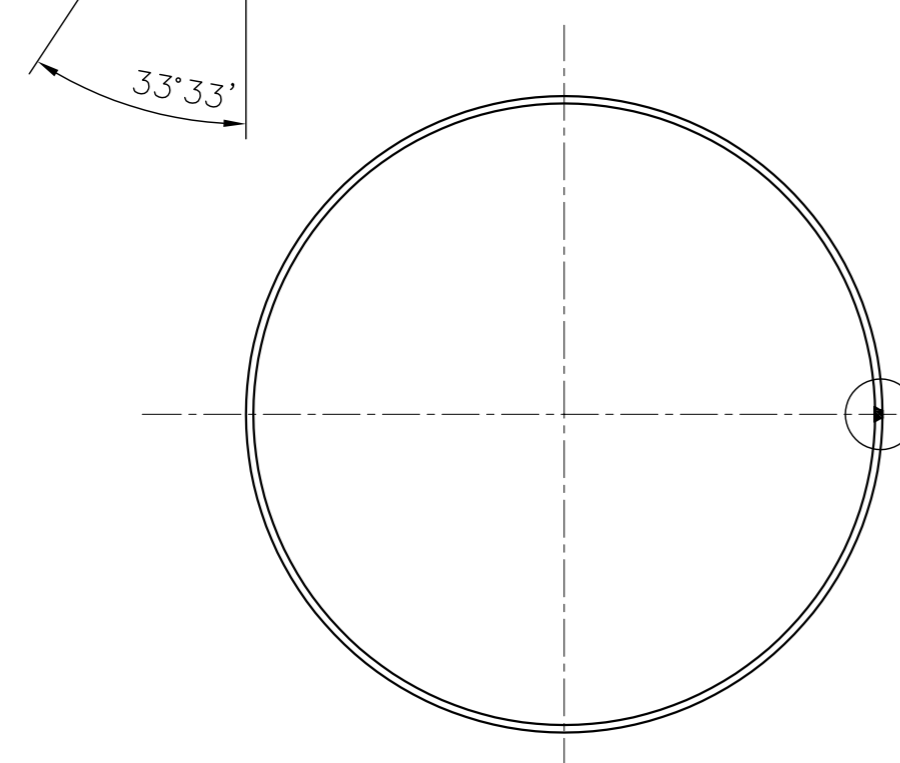
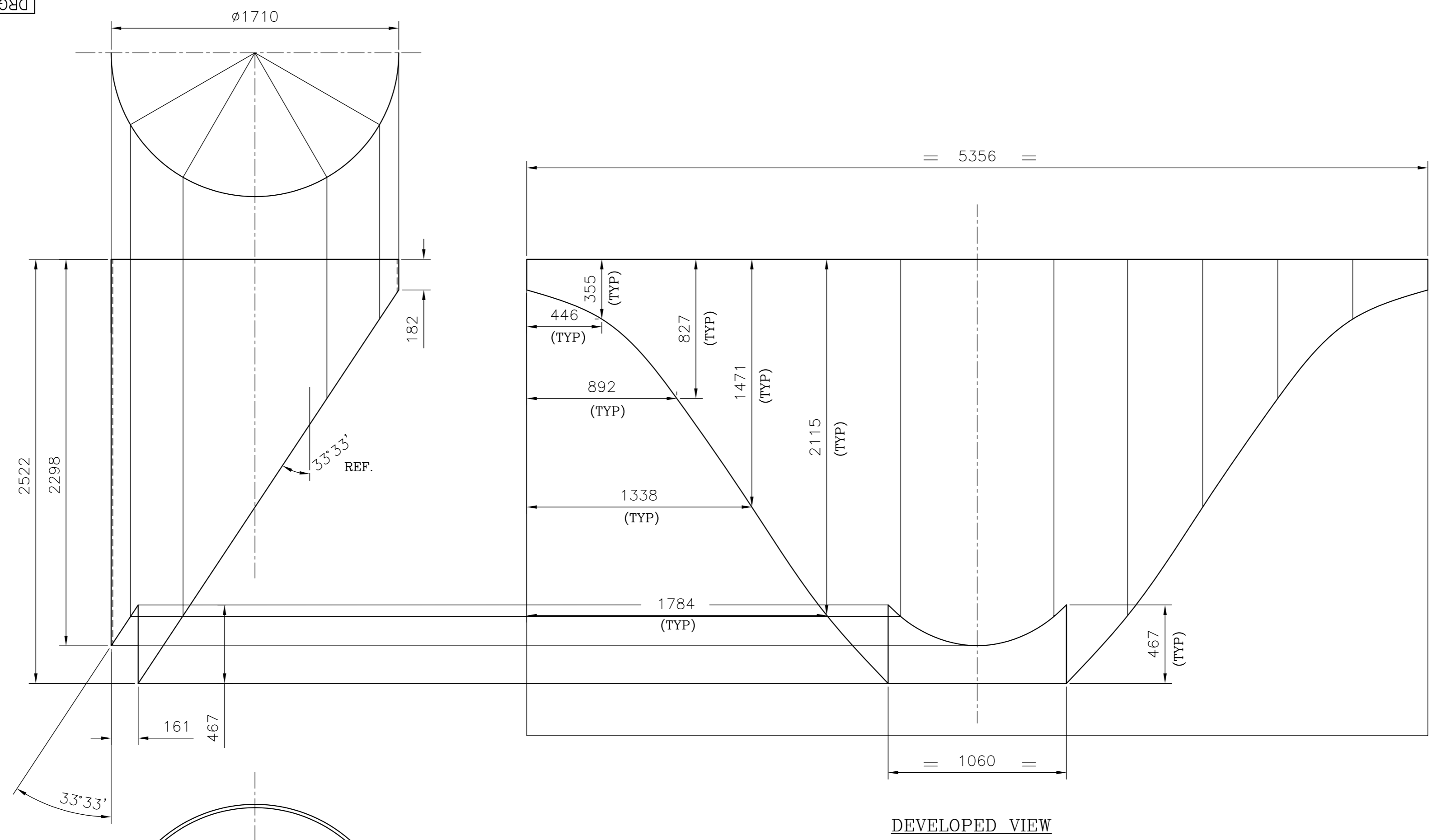

DEVELOPED VIEW

01	PLATE		01	PL 5X5356X2522	AA1011808013 AA10108	260.00	1
ITEM NO.	DESCRIPTION	DRAWING NO.	VAR. NO.	RAW MATERIAL SIZE OR CASTING DRG. NO. OR FORGING DRG. NO.	MATERIAL CODE	NET WT.	GROSS WT.
					MATERIAL SPECN.	QUANTITY	

THE FOLLOWING CONDITIONS APPLY EXCEPT OTHERWISE STATED.

- REF. TO HY0230261 FOR UNSPECIFIED TOLERANCES.
- CHAMFER M/CD. SHARP EDGES AT 45°.
- INTERNAL M/CD. CORNER RADII 1 TO 0.7
- THE SURFACE ROUGHNESS WHERE-EVER NOT SHOWN SHALL BE TAKEN FROM THE SURFACE ROUGHNESS SHOWN OUT SIDE THE BACK SLASH GIVEN OR THE TOP MOST RIGHT CORNER OF THE DRG.

TYPE OF PRODUCT: BBD 4772 TUBE MILLS
 NAME OF CUSTOMER/PROJECT: BHARAT HEAVY ELECTRICALS LIMITED HYDERABAD

DRN.	NAME	DATE	NO.OF VAR.
Y.PHANI		03.10.05	
CHD.	RAZVI	03.10.05	
APPD.	T.M.R	03.10.05	

DEPT. PULV ENGG. CODE 446
 UNTO. DIMS. GR. 4/M/7
 SCALE 1:20
 WEIGHT (KG) 260.00
 REF. TO ASSY DRG. 0-62-309-50581
 ITEM NO. 01
 NO.OF ITEMS 17

TITLE: CYLINDER-I (REFUSAL BOX)
 DRAWING NO. 2-62-309-50268
 SHEET NO. 01 NO OF SHEETS 01

REV.	DATE	ALTERED CHD.	APPD.	REV.	DATE	ALTERED CHD.	APPD.	REV.	DATE	ALTERED Y.PHANI CHD.	APPD.
				02	03.10.05					RAZVI	T.M.R

DRG. REDRAWN INCORPORATED EARLIER CHANGES
 MATL. CODE WAS HY1051876028
 MATL. SPECN. WAS HY10576

INVENTORY NO. SIGN. AND DATE REF. DRG. NO. COMPUTER FILE NAME
 26250269 THE INFORMATION ON THIS DOCUMENT IS THE PROPERTY OF BHARAT HEAVY ELECTRICALS LIMITED. IT MUST NOT BE USED DIRECTLY OR INDIRECTLY IN ANY WAY DETRIMENTAL TO THE INTEREST OF THE COMPANY
 DRG. NO. 2-62-309-50269

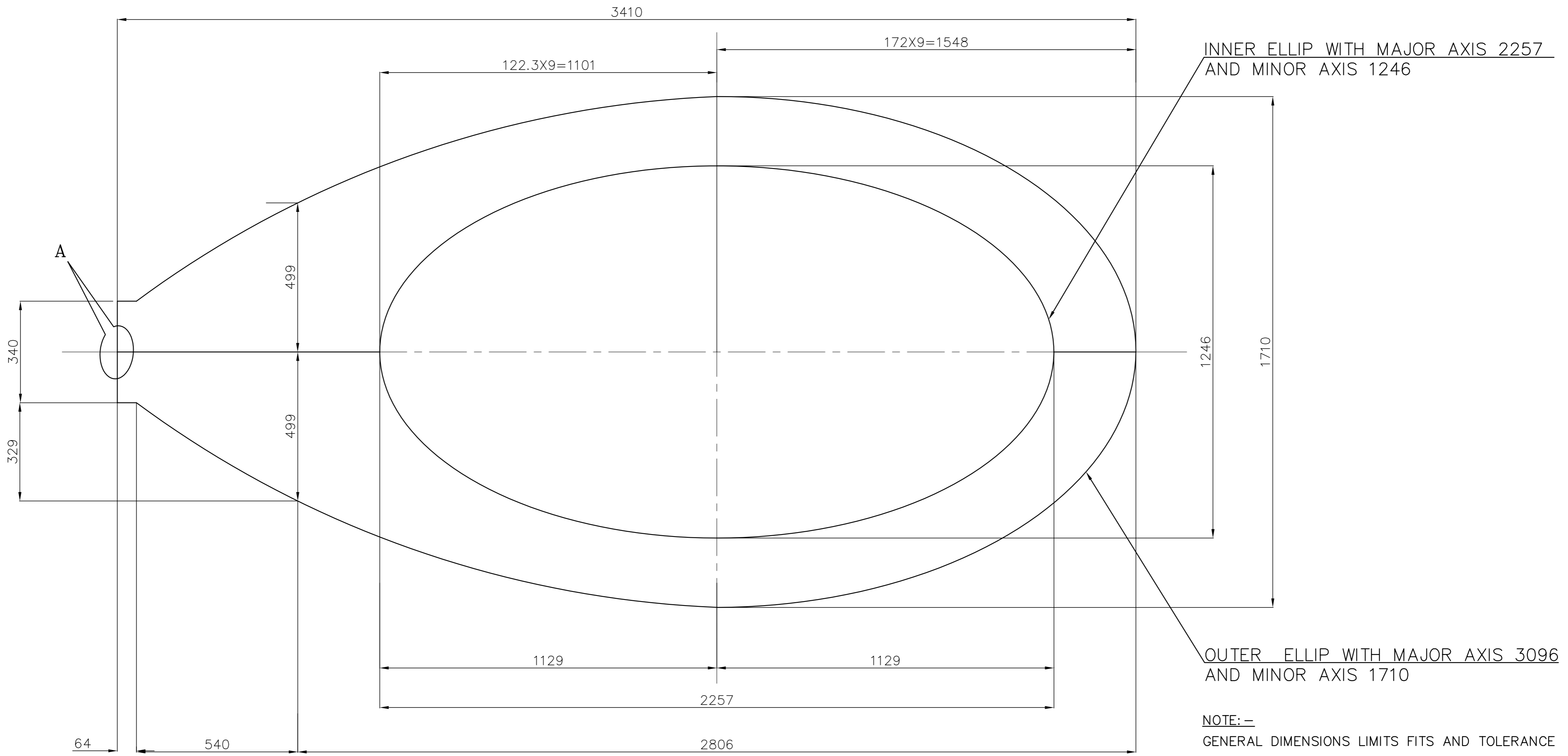

INNER ELLIP WITH MAJOR AXIS 2257 AND MINOR AXIS 1246

OUTER ELLIP WITH MAJOR AXIS 3096 AND MINOR AXIS 1710

NOTE:-
GENERAL DIMENSIONS LIMITS FITS AND TOLERANCE AS PER P.S.HY 0230261

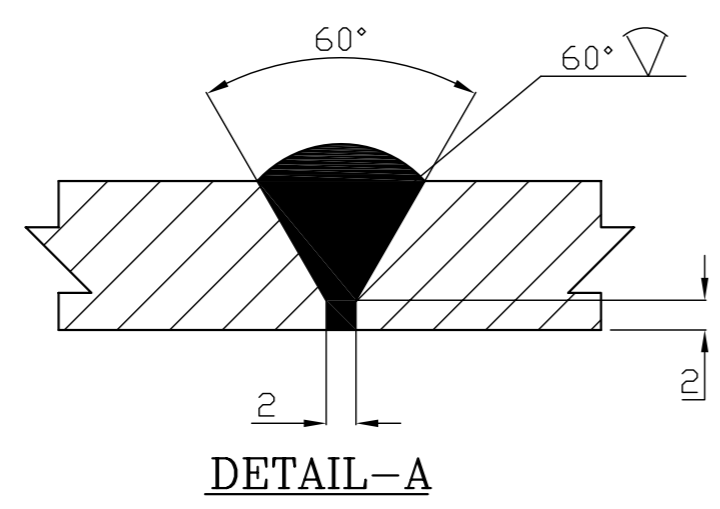

DETAIL-A

01	PLATE			PL.12X855X3410	HY1051876095	131.00	
					HY10576		2
ITEM NO.	DESCRIPTION	DRAWING NO.	VAR. NO.	RAW MATERIAL SIZE OR CASTING DRG. NO. OR FORGING DRG. NO.	MATERIAL CODE	NET WT.	GROSS WT.
							QUANTITY

THE FOLLOWING CONDITIONS APPLY EXCEPT OTHERWISE STATED.				TYPE OF PRODUCT				BBD 4772 TUBE MILL			
1. REF. TO HY0230261 FOR UNSPECIFIED TOLERANCES.				NAME OF CUSTOMER/PROJECT				BHARAT HEAVY ELECTRICALS LIMITED			
2. CHAMFER M/CD. SHARP EDGES AT 45°.				DRN.				RAZVI			
3. INTERNAL M/CD. CORNER RADII 1 TO 0.7				CHD.				N.D.SAMUJ			
4. THE SURFACE ROUGHNESS WHERE-EVER NOT SHOWN SHALL BE TAKEN FROM THE SURFACE ROUGHNESS SHOWN OUT SIDE THE BACK SLASH GIVEN OR THE TOP MOST RIGHT CORNER OF THE DRG.				APPD.				T.M.RAO			
DRAWING REDRAWN				DEPT. PULV ENGG. CODE 446				UNTO. DIMS. GR. 4/M/4			
				SCALE				1:10			
				WEIGHT (KG)				262.00			
				REF. TO ASSY DRG.				0.62.309.50581			
				ITEM NO.				06			
				NO.OF ITEMS				17			
				TITLE				TRANSITION PLATE-IV (REFUSAL BOX)			
				DRAWING NO.				2-62-309-50269			
				REV.				03			
				SHEET NO. 01				NO OF SHEETS 01			

REV.	DATE	ALTERED CHD.	APPD.	REV.	DATE	ALTERED CHD.	APPD.	REV.	DATE	ALTERED CHD.	APPD.
								03	10.3.06	RAZVI N.D.S	T.M.R

(ALL DIMENSIONS ARE IN mm)

FIRST ANGLE PROJECTION

793440/2022/FSIP-R&D_UNIT

DRG.NO. 3-62-309-50345

THE INFORMATION ON THIS DOCUMENT IS THE PROPERTY OF BHARAT HEAVY ELECTRICALS LTD. IT MUST NOT BE USED DIRECTLY OR INDIRECTLY IN ANY WAY DETRIMENTAL TO THE INTEREST OF THE COMPANY.

36250345.DWG FILE NAME

REF.DRG.NO.

INVENTORY NO.

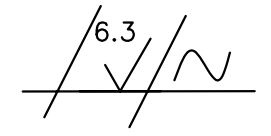

WPS NO=WE006

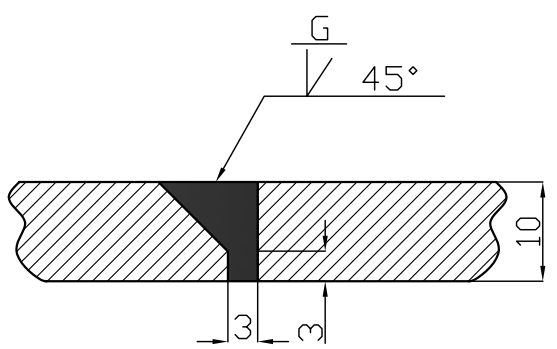
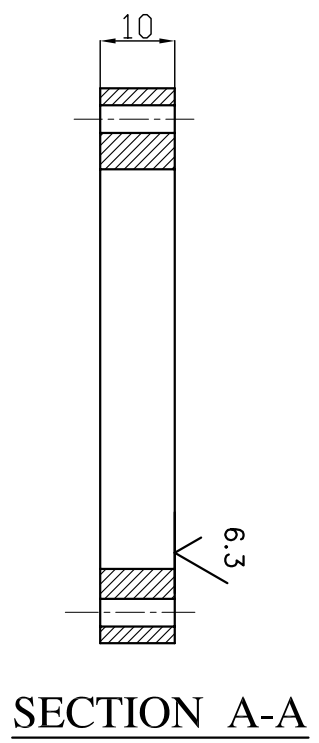
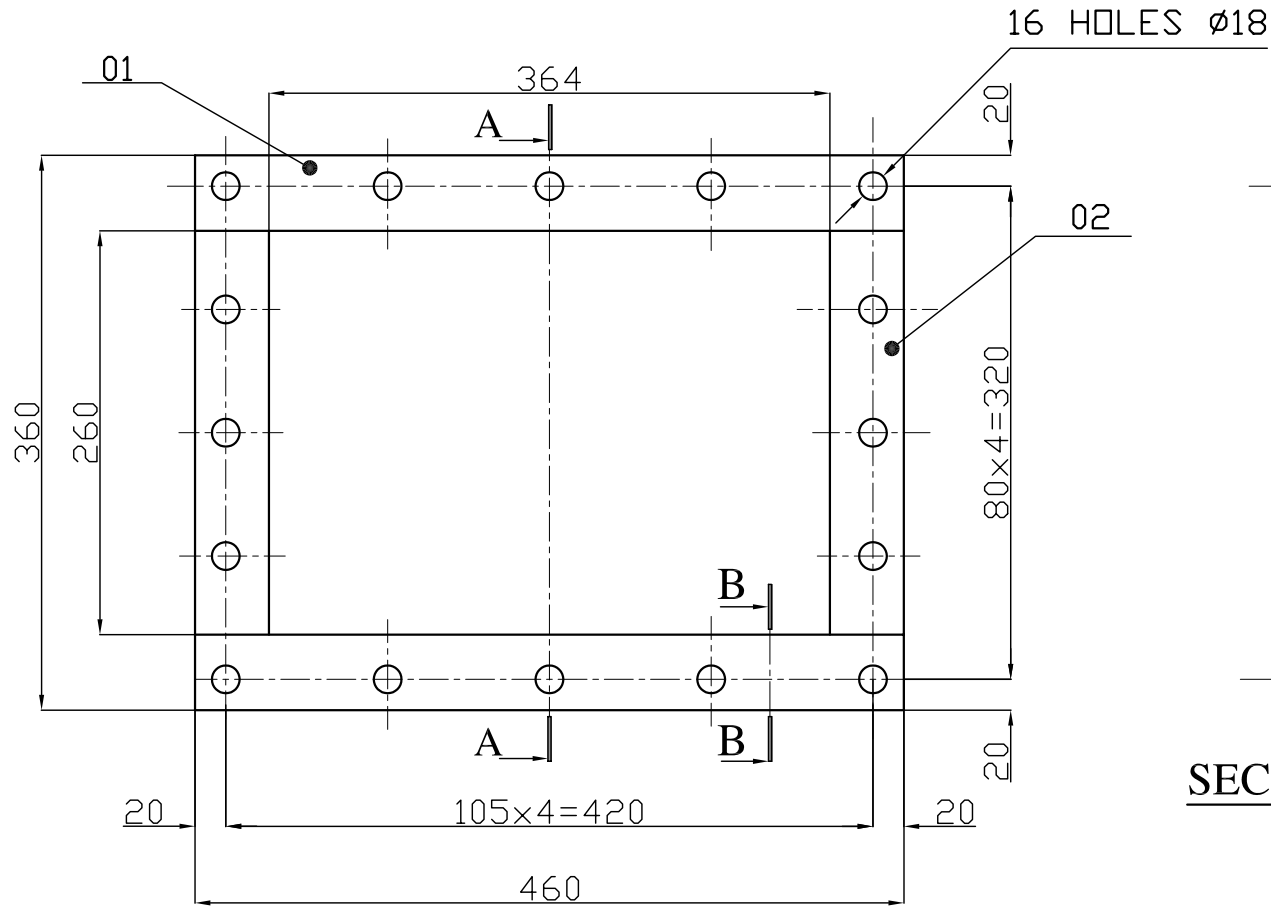

SECTION B-B

ITEM NO	DESCRIPTION	DRAWING NO.	VAR. NO.	RAW MATERIAL SIZE OR CASTING DRG.NO. OR FORGING DRG.NO.	MATERIAL CODE	NET WT.	GROSS WT.
					QUANTITY		
02	PLATE -II			PL12X50X260	AA1011819090		1.020
					AA10119		2
01	PLATE -I			PL12X50X460	AA1011819090		1.810
					AA10119		2

THE FOLLOWING CONDITIONS APPLY EXCEPT OTHERWISE STATED...

- REF.TO HY0230261 FOR UT TOLERANCES.
- CHAMFER M/CD SHARP ED 1.2 TO 1.0 AT 45°.
- INTERNAL M/CD CORNER RADII 1 TO 0.7.
- THE SURFACE ROUGHNESS WHEREVER NOT SHOWN SHALL BE TAKEN FROM THE SURFACE ROUGHNESS SHOWN OUT SIDE BACK SLASHES GIVEN AT THE TOP MOST RIGHT CORNER OF THE DRG.



TYPE OF PRODUCT OR NAME OF CUSTOMER/PROJECT **BBD 4772 TUBE MILL**

DRN.	NAME	SIGN.	DATE	NO.OF VAR.
	VASAVI		27.10.07	
	PAVAN		27.10.07	
	T.M.R		27.10.07	

DEPT. PULVE.ENGG	SCALE 1:1	WEIGHT (KG) 5.660	REF. TO ASSY DRG. 0-62-309-50581	ITEM NO. 11	NO.OF ITEMS 17
------------------	-----------	-------------------	----------------------------------	-------------	----------------

TITLE FLANG III (REFUSAL BOX)	DRAWING NO. 3-62-309-50345	REV. 01
SHEET NO. 01	NO OF SHEETS 01	

25-03-2010 15:54:55

This Drawing is printed from Engineering Digital Archive System (EAS) Therefore signatures are not essentially required.

(ALL DIMENSIONS ARE IN mm)

FIRST ANGLE PROJECTION

793440/2022/FSIP-R&D_UNIT

DRG.NO. 3-62-309-50354

THE INFORMATION ON THIS DOCUMENT IS THE PROPERTY OF BHARAT HEAVY ELECTRICALS LTD. IT MUST NOT BE USED DIRECTLY OR INDIRECTLY IN ANY WAY DETRIMENTAL TO THE INTEREST OF THE COMPANY.

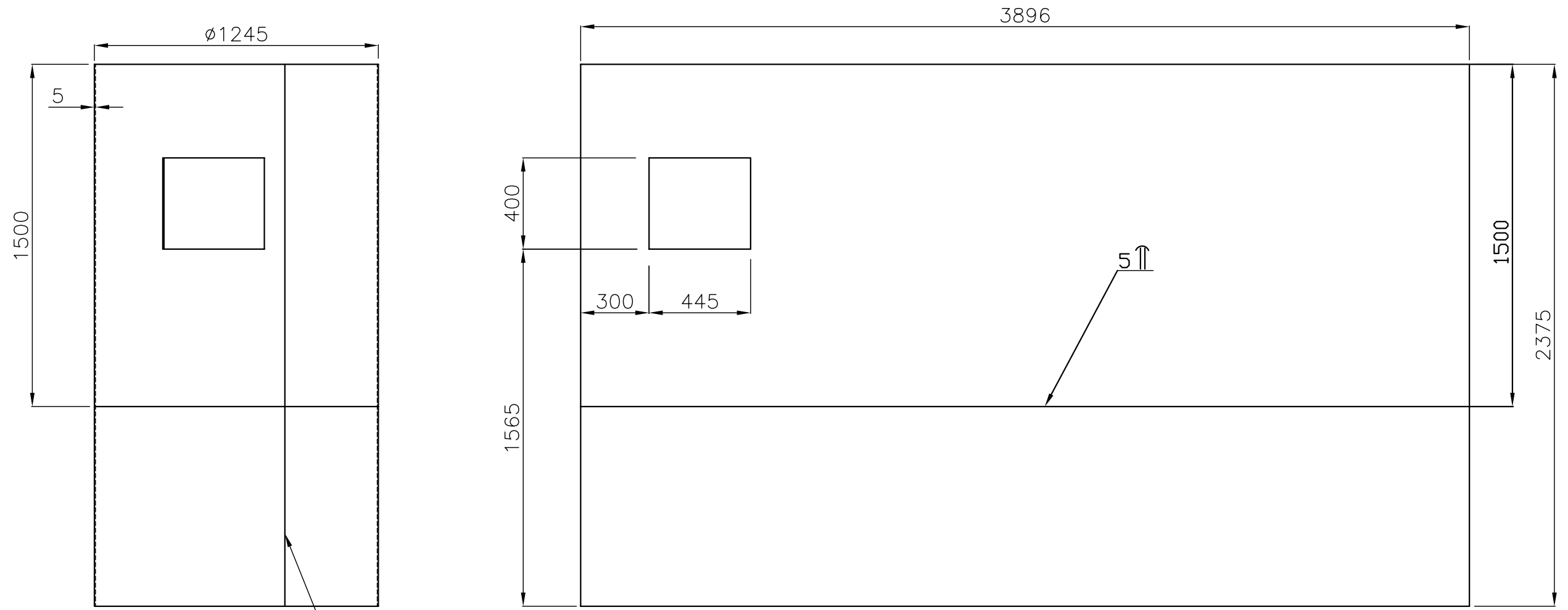

DEVELOPED VIEW

36230950354.S00-R02.dwg FILE NAME

REF.DRG.NO.

INVENTORY NO.

01	PLATE			PL5X2375X3896	AA1011808013	355.80	
					AA10108		1
ITEM NO	DESCRIPTION	DRAWING NO.	VAR. NO.	RAW MATERIAL SIZE OR CASTING DRG.NO. OR FORGING DRG.NO.	MATERIAL CODE	NET WT.	GROSS WT.
					MATERIAL SPECN.	QUANTITY	

THE FOLLOWING CONDITIONS APPLY EXCEPT OTHERWISE STATED...

- REF.TO HY0230261 FOR UT TOLERANCES.
- CHAMFER M/CD SHARP ED 1.2 TO 1.0 AT 45°.
- INTERNAL M/CD CORNER RADII 1 TO 0.7.
- THE SURFACE ROUGHNESS WHEREVER NOT SHOWN SHALL BE TAKEN FROM THE SURFACE ROUGHNESS SHOWN OUT SIDE BACK SLASHES GIVEN AT THE TOP MOST RIGHT CORNER OF THE DRG.

TYPE OF PRODUCT OR NAME OF CUSTOMER/PROJECT: BBD4772 TUBE MILL

DEPT.	PULVE.ENGG	SCALE	1:20	WEIGHT (KG)	355.00	REF. TO ASSY DRG.	0-62-309-50581	ITEM NO.	02	NO.OF ITEMS	17
CODE	446	TITLE		CYLINDER-II (REFUSAL BOX)		DRAWING NO.	3-62-309-50354		REV.	02	
				SHEET NO.	01	NO OF SHEETS		01			



BHARAT HEAVY ELECTRICALS LTD. HYDERABAD

RESTRICTED USE

REV.	DATE	ALTERED	REV.	DATE	ALTERED
		CHD.	02	04.9.09	CHD.C.MOHAN
		APPD.			APPD. TMR
ZONE		DRAWING REDRAWN . MATL.CODE WAS HY1051876028 MATL.SPEC. WAS HY10576			

24-04-2010 10:49:48

This Drawing is printed from Engineering Digital Archive System (EDAS) Therefore signatures are not essentially required.

(ALL DIMENSIONS ARE IN mm)

FIRST ANGLE PROJECTION

793440/2022/ESIP-R&D_UNIT

DRG.NO. 3-62-309-50355

THE INFORMATION ON THIS DOCUMENT IS THE PROPERTY OF BHARAT HEAVY ELECTRICALS LTD. IT MUST NOT BE USED DIRECTLY OR INDIRECTLY IN ANY WAY DETRIMENTAL TO THE INTEREST OF THE COMPANY.

36250355.DWG FILE NAME

REF.DRG.NO.

INVENTORY NO.

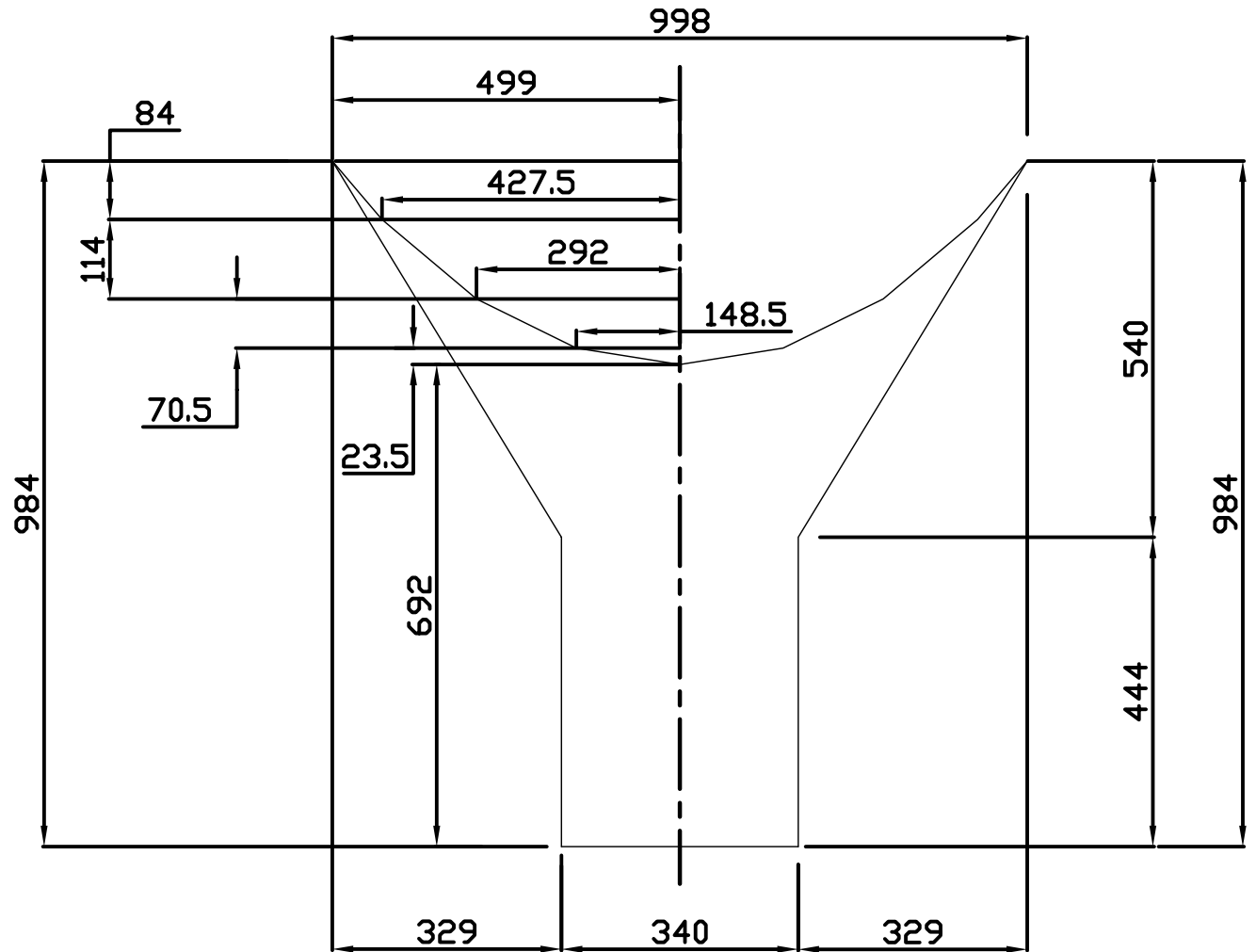

01	PLATE			PL.5X998X984	AA1011808013	14.40	
					AA10108		1
ITEM NO	DESCRIPTION	DRAWING NO.	VAR. NO.	RAW MATERIAL SIZE OR CASTING DRG.NO. OR FORGING DRG.NO.	MATERIAL CODE	NET WT.	GROSS WT.
					MATERIAL SPECN.	QUANTITY	

THE FOLLOWING CONDITIONS APPLY EXCEPT OTHERWISE STATED...

- REF.TO HY0230261 FOR U TOLERANCES.
- CHAMFER M/CD SHARP ED 1.2 TO 1.0 AT 45°.
- INTERNAL M/CD CORNER RADII 1 TO 0.7.
- THE SURFACE ROUGHNESS WHEREVER NOT SHOWN SHALL BE TAKEN FROM THE SURFACE ROUGHNESS SHOWN OUT SIDE BACK SLASHES GIVEN AT THE TOP MOST RIGHT CORNER OF THE DRG.



TYPE OF PRODUCT OR NAME OF CUSTOMER/PROJECT BBD4772 TUBE MILL

	NAME	SIGNATURE	DATE	NO.OF VAR.
DRN.	RAZVI		30.9.05	
CHD.	N.D.SAMUI		30.9.05	
APPD.	TMR		30.9.05	

DEPT. PULVE.ENGG	SCALE	WEIGHT (KG)	REF. TO ASSY DRG.	ITEM NO.	NO.OF ITEMS
CODE 446	1:10	14.40	0.52.309.50581	03	17

TITLE	DRAWING NO.	REV.
TRANSITION PLATE-I (REFUSAL BOX)	3-62-309-50355	02
	SHEET NO. 01	NO OF SHEETS 01

REV.	DATE	ALTERED	REV.	DATE	ALTERED
		CHD.	02	30.9.05	CHD.N.D.S
		APPD.			APPD.T.M.R
ZONE			ZONE		DRAWING REDRAWN
					MATL.CODE WAS HY1051876028
					MATL. SPEC. WAS HY10576

06-05-2008 09:10:36

This Drawing is printed from Engineering Digital Archive System (EDAS) Therefore signatures are not essentially required.

(ALL DIMENSIONS ARE IN mm)

FIRST ANGLE PROJECTION

793440/2022/ESIP-R&D_UNIT

DRG.NO. 3-62-309-50356

THE INFORMATION ON THIS DOCUMENT IS THE PROPERTY OF BHARAT HEAVY ELECTRICALS LTD. IT MUST NOT BE USED DIRECTLY OR INDIRECTLY IN ANY WAY DETRIMENTAL TO THE INTEREST OF THE COMPANY.

36250356.dwg FILE NAME

REF.DRG.NO.

INVENTORY NO.

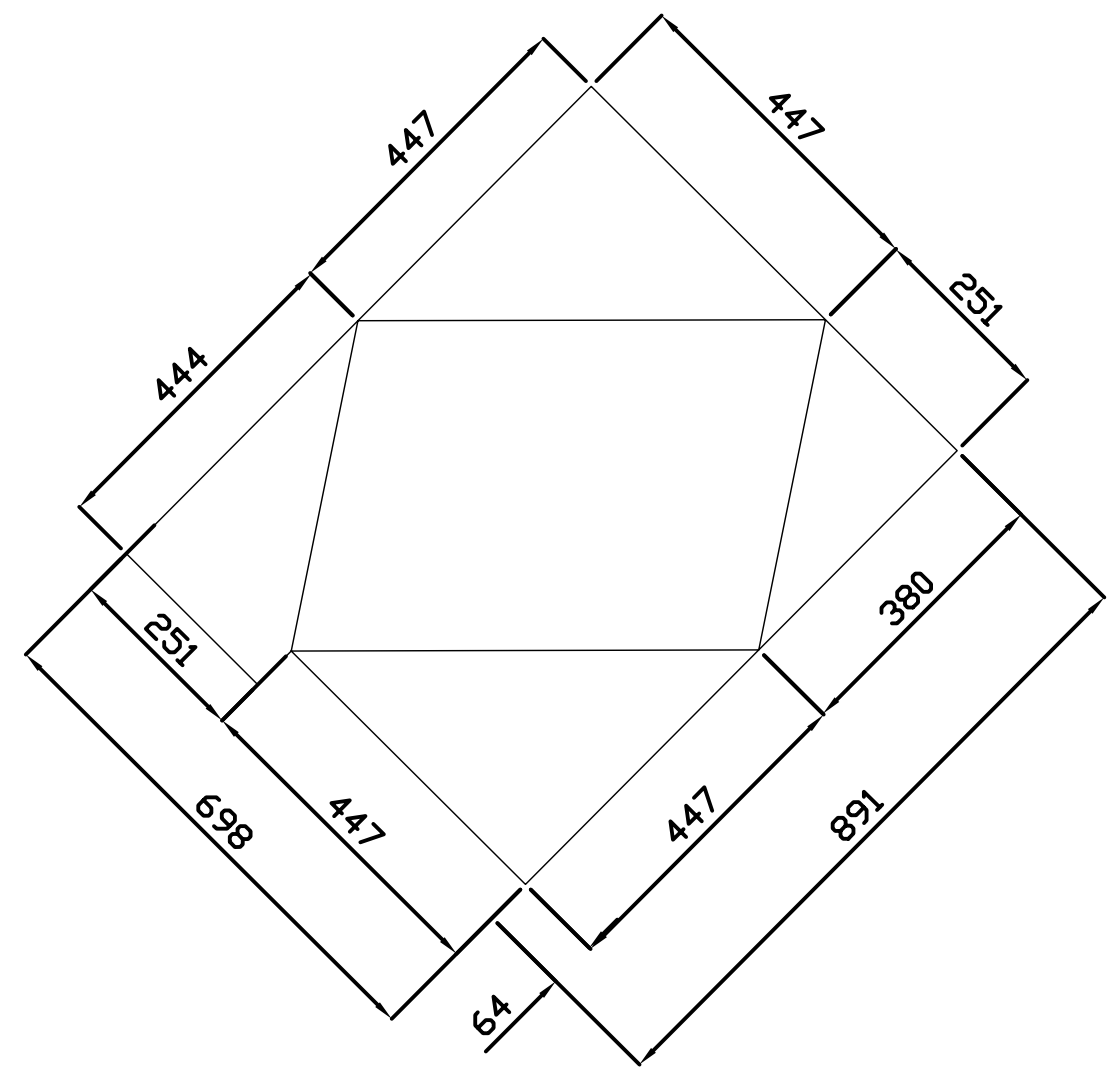
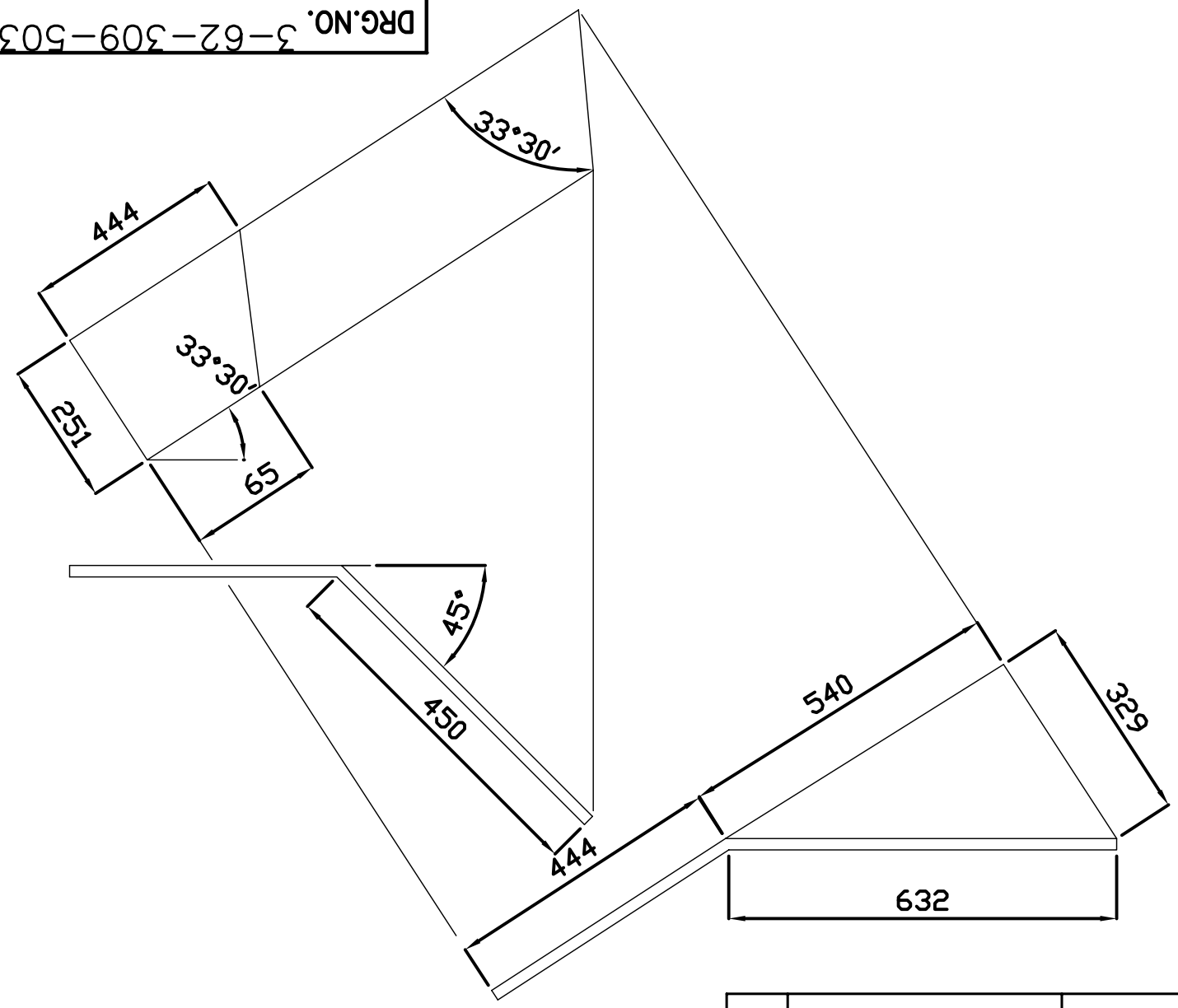

01	TRANSITON PLATE			PL12X698X891	HY1051876095		32.40
					HY10576		1
ITEM NO.	DESCRIPTION	DRAWING NO.	VAR. NO.	RAW MATERIAL SIZE OR CASTING DRG.NO. OR FORGING DRG.NO.	MATERIAL CODE	NET WT.	GROSS WT.
					MATERIAL SPECN.	QUANTITY	

THE FOLLOWING CONDITIONS APPLY EXCEPT OTHERWISE STATED...

- REF.TO HY0230261 FOR UN TOLERANCES.
- CHAMFER M/CD SHARP ED 1.2 TO 1.0 AT 45°.
- INTERNAL M/CD CORNER RADII 1 TO 0.7.
- THE SURFACE ROUGHNESS WHEREVER NOT SHOWN SHALL BE TAKEN FROM THE SURFACE ROUGHNESS SHOWN OUT SIDE BACK SLASHES GIVEN AT THE TOP MOST RIGHT CORNER OF THE DRG.



TYPE OF PRODUCT OR NAME OF CUSTOMER/PROJECT		BBD 4772 TUBE MILL			
 BHARAT HEAVY ELECTRICALS LTD. HYDERABAD	DRN.	NAME	SIGNATURE	DATE	NO.OF VAR.
	CHD.	PAVAN		8.11.07	
	APPD.	T.M.R		8.11.07	
DEPT. PULVE.ENGG	SCALE 1:1	WEIGHT (KG) 32.40	REF. TO ASSY DRG. 0-62-309-50581	ITEM NO. 04	NO.OF ITEMS 17
CODE 446	TITLE TRANSITION PLATE-II (REFUSAL BOX)		DRAWING NO. 3-62-309-50356	REV. 01	
		SHEET NO. 01	NO OF SHEETS 01		

RESTRICTED USE

06-05-2008 09:10:44

This Drawing is printed from Engineering Digital Archive System (EDAS) Therefore signatures are not essentially required.

(ALL DIMENSIONS ARE IN mm)

FIRST ANGLE PROJECTION

793440/2022/ESIP-R&D_UNIT

DRG.NO. 3-62-309-50357

THE INFORMATION ON THIS DOCUMENT IS THE PROPERTY OF BHARAT HEAVY ELECTRICALS LTD. IT MUST NOT BE USED DIRECTLY OR INDIRECTLY IN ANY WAY DETRIMENTAL TO THE INTEREST OF THE COMPANY.

36250357.dwg FILE NAME

REF.DRG.NO.

INVENTORY NO.

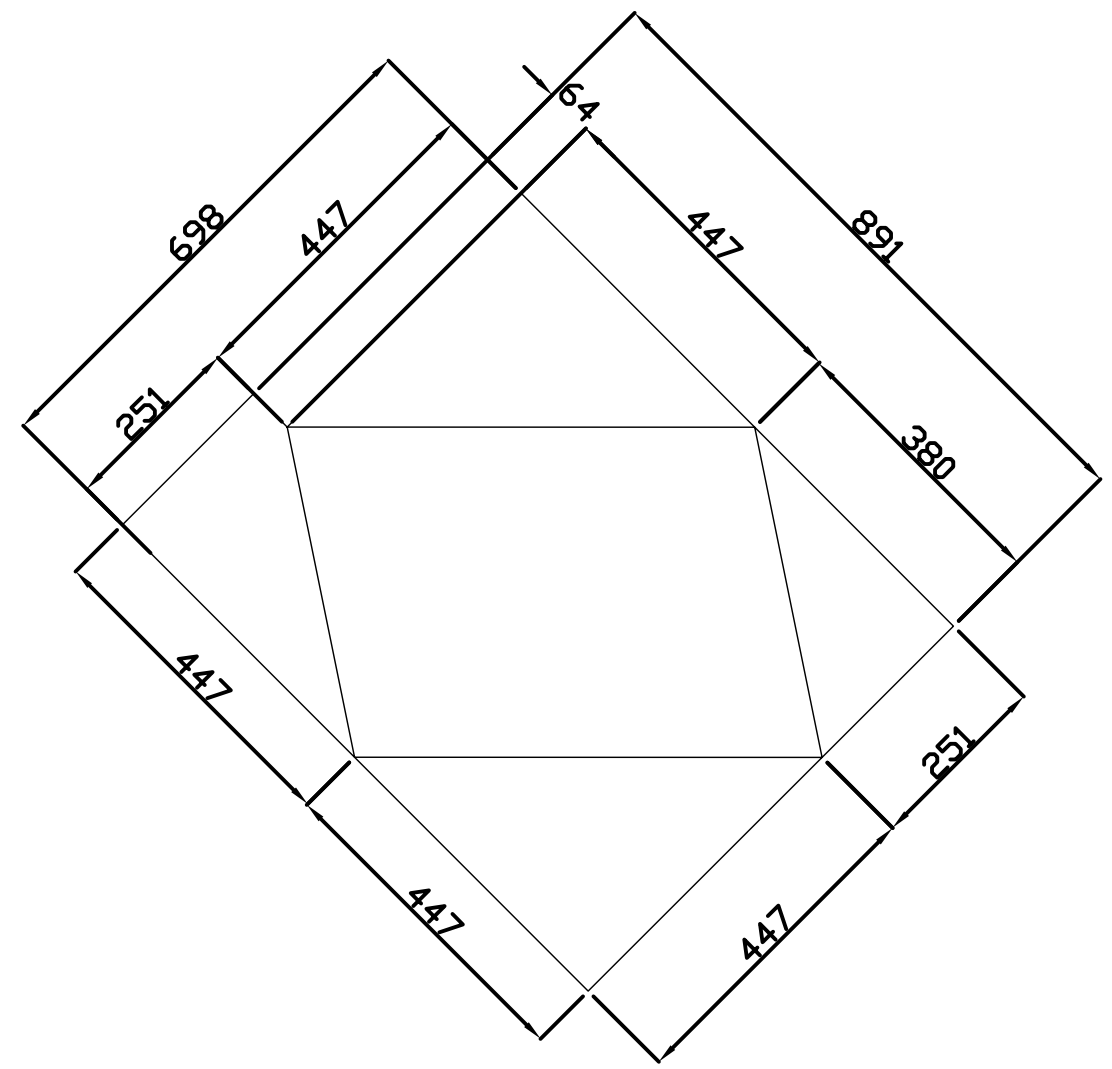
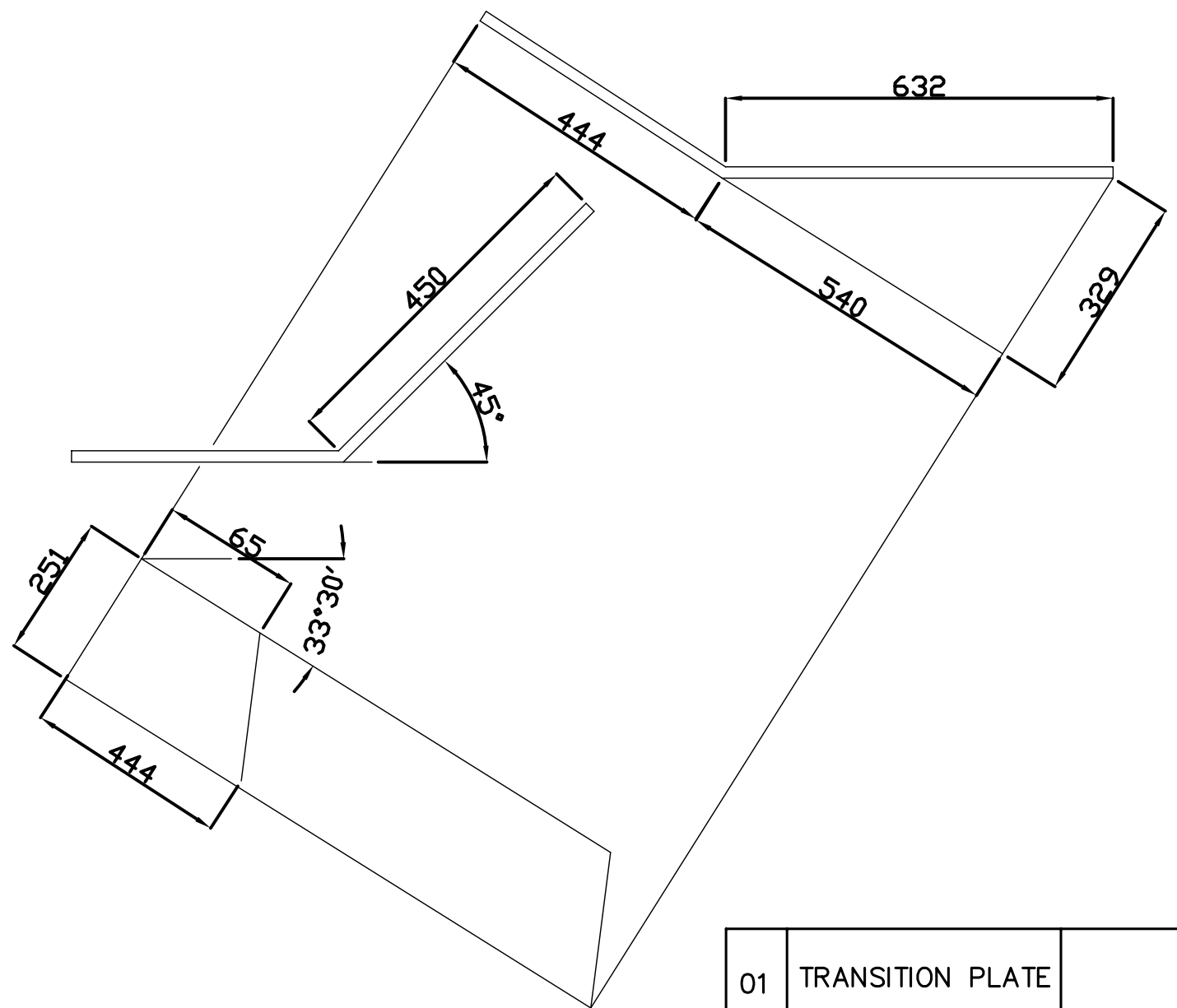

01	TRANSITION PLATE			PL12X698X891	HY1051876095		32.64
					HY10576		1
ITEM NO.	DESCRIPTION	DRAWING NO.	VAR. NO.	RAW MATERIAL SIZE OR CASTING DRG.NO. OR FORGING DRG.NO.	MATERIAL CODE	NET WT.	GROSS WT.
					MATERIAL SPECN.	QUANTITY	

THE FOLLOWING CONDITIONS APPLY EXCEPT OTHERWISE STATED...

- REF.TO HY0230261 FOR U TOLERANCES.
- CHAMFER M/CD SHARP ED 1.2 TO 1.0 AT 45°.
- INTERNAL M/CD CORNER RADII 1 TO 0.7.
- THE SURFACE ROUGHNESS WHEREVER NOT SHOWN SHALL BE TAKEN FROM THE SURFACE ROUGHNESS SHOWN OUT SIDE BACK SLASHES GIVEN AT THE TOP MOST RIGHT CORNER OF THE DRG.



TYPE OF PRODUCT OR NAME OF CUSTOMER/PROJECT **BBD 4772 TUBE MILL**

	NAME	SIGNATURE	DATE	NO.OF VAR.
DRN.	VASAVI		8.11.07	
CHD.	PAVAN		8.11.07	
APPD.	T.M.R		8.11.07	

DEPT.	PULVE.ENGG	SCALE	1:1	WEIGHT (KG)	32.64	REF. TO ASSY DRG.	0-62-309-50581	ITEM NO.	05	NO.OF ITEMS	17
CODE	446	TITLE		TRANSITION PLATE-III (REFUSAL BOX)		DRAWING NO.	3-62-309-50357	REV.	02		
						SHEET NO.	01	NO OF SHEETS		01	



06-05-2008 09:10:51

This Drawing is printed from Engineering Digital Archive System (EDAS) Therefore signatures are not essentially required.

(ALL DIMENSIONS ARE IN mm)

FIRST ANGLE PROJECTION

793440/2022/FSIP-R&D_UNIT

DRG.NO. 3-62-309-50358

THE INFORMATION ON THIS DOCUMENT IS THE PROPERTY OF BHARAT HEAVY ELECTRICALS LTD. IT MUST NOT BE USED DIRECTLY OR INDIRECTLY IN ANY WAY DETRIMENTAL TO THE INTEREST OF THE COMPANY.

36230950358-S00-R00 FILE NAME

REF.DRG.NO.

INVENTORY NO.

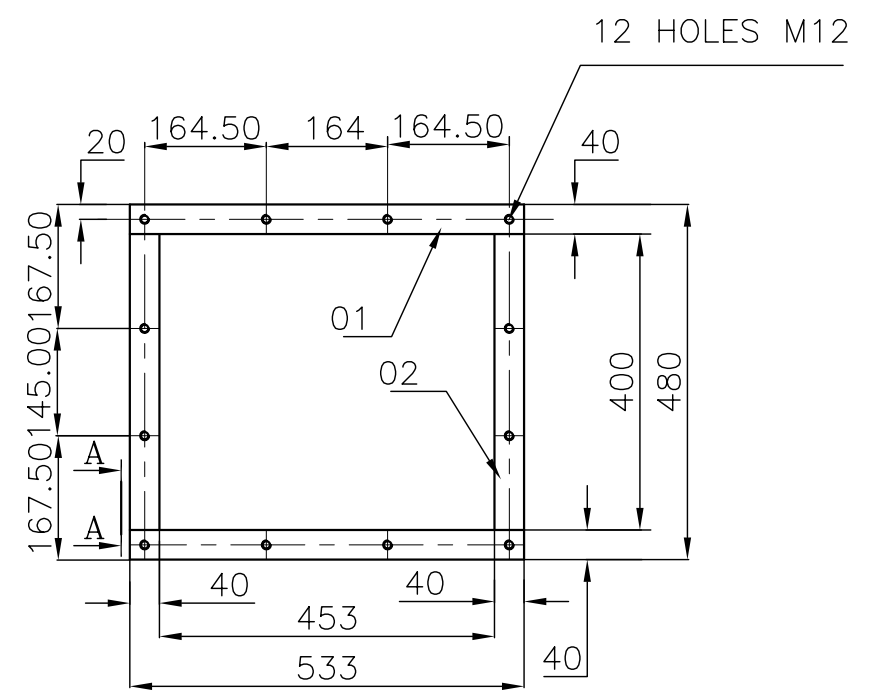
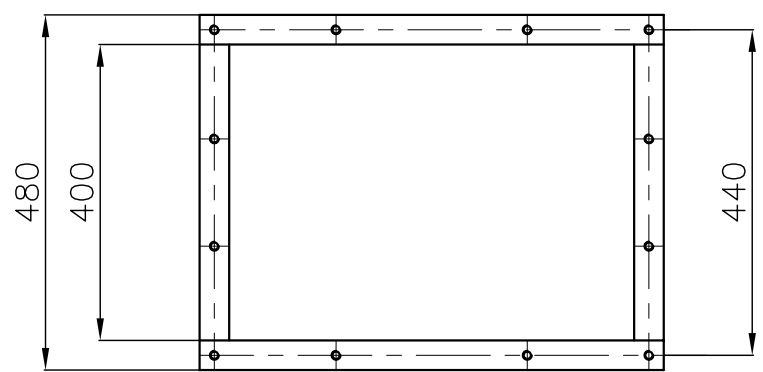
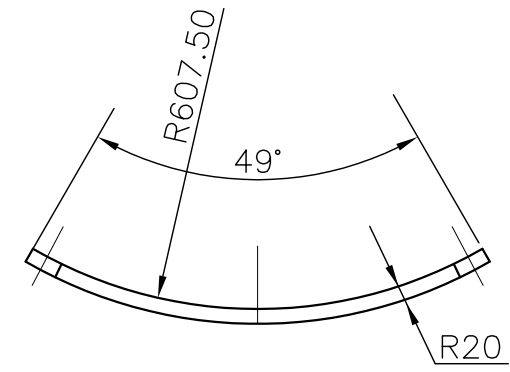
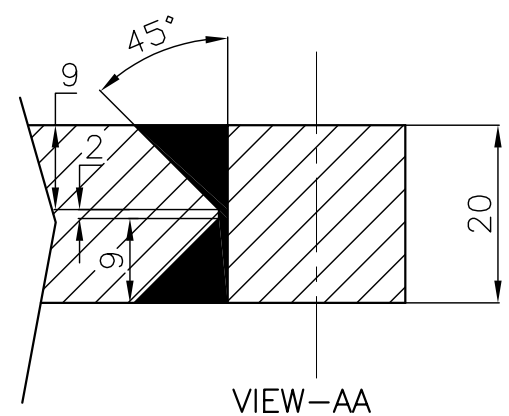

DEVELOPED VIEW

ITEM NO	DESCRIPTION	DRAWING NO.	VAR. NO.	RAW MATERIAL SIZE OR CASTING DRG.NO. OR FORGING DRG.NO.	MATERIAL CODE	NET WT.	GROSS WT.
02	PLATE			PL.20X40X400	AA1011819139	2.50	
					AA10119		2
01	PLATE			PL.20X40X533	AA1011819139	3.40	
					AA10119		2
					MATERIAL SPECN.	QUANTITY	

GENERAL DIMENSION LIMITS FITES AND TOLERANCES AS PER P.S.HY 0230261

THE FOLLOWING CONDITIONS APPLY EXCEPT OTHERWISE STATED...

- REF.TO HY0230261 FOR UT TOLERANCES.
- CHAMFER M/CD SHARP ED 1.2 TO 1.0 AT 45°.
- INTERNAL M/CD CORNER RADII 1 TO 0.7.
- THE SURFACE ROUGHNESS WHEREVER NOT SHOWN SHALL BE TAKEN FROM THE SURFACE ROUGHNESS SHOWN OUT SIDE BACK SLASHES GIVEN AT THE TOP MOST RIGHT CORNER OF THE DRG.



TYPE OF PRODUCT OR NAME OF CUSTOMER/PROJECT: BBD 4772 TUBE MILL

DRN.	NAME	SIGN.	DATE	NO.OF VAR.
	RAZVI		19.4.10	
CHD.	N.D.S		19.4.10	
APPD.	T.M.RAO		19.4.10	

DEPT.	SCALE	WEIGHT (KG)	REF. TO ASSY DRG.	ITEM NO.	NO.OF ITEMS
PULVE.ENGG	1:10	11.80	0.62.309.50581	08	17
CODE	TITLE		DRAWING NO.	REV.	
446	DOOR FLANGE (REFUSAL)		3-62-309-50358	01	
	SHEET NO.	NO OF SHEETS			
	01	01			

REV.	DATE	ALTERED	REV.	DATE	ALTERED
		CHD. APPD.	01	19.4.10	CHD.N.D.S APPD. T.M.R
ZONE	DRAWING REDRAWN				ZONE

20-04-2010 09:47:34

This Drawing is printed from Engineering Digital Archive System (EAS) Therefore signatures are not essentially required.

(ALL DIMENSIONS ARE IN mm)

FIRST ANGLE PROJECTION

793440/2022/FSIP-R&D_UNIT

THE INFORMATION ON THIS DOCUMENT IS THE PROPERTY OF BHARAT HEAVY ELECTRICALS LTD. IT MUST NOT BE USED DIRECTLY OR INDIRECTLY IN ANY WAY DETRIMENTAL TO THE INTEREST OF THE COMPANY.

DRG.NO. 3-62-309-50359

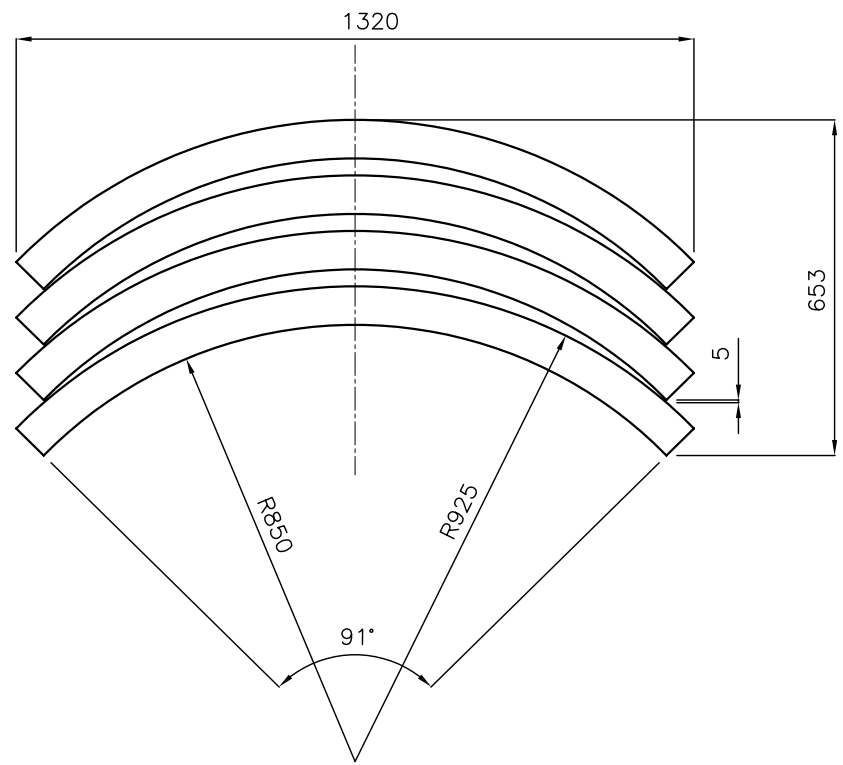
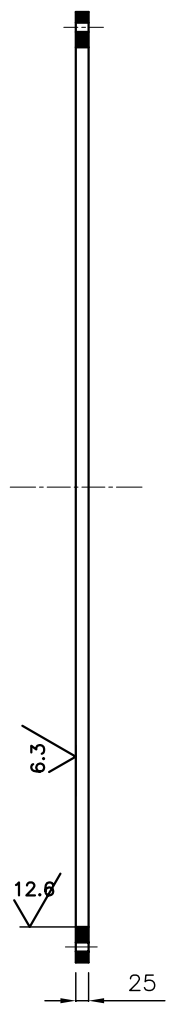
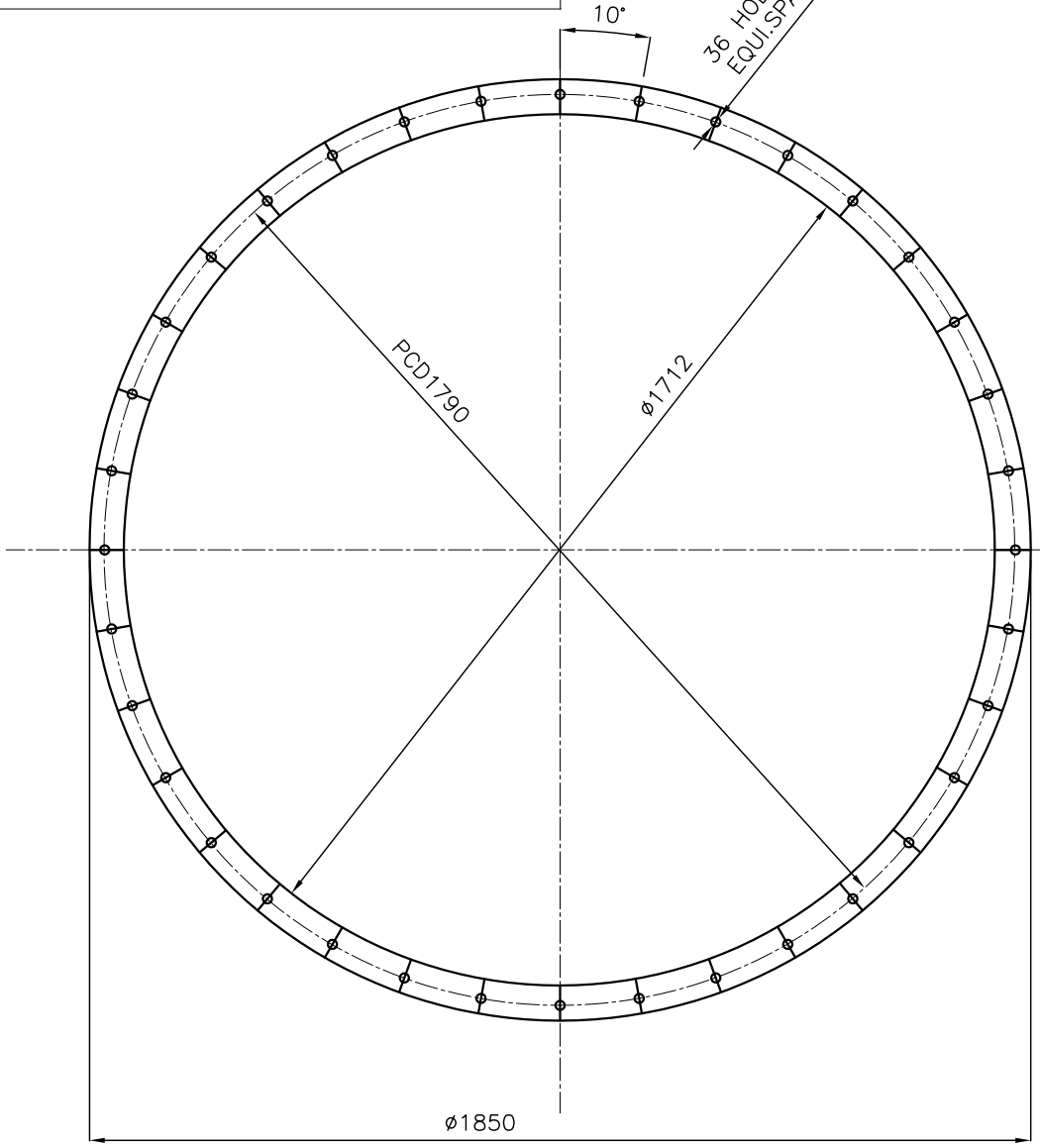

6.3 / 12.6 / ~
 WPS NO=WE001

CUTTING PLAN WITH CUTTING ALLOWANCE

36250359DRG

FILE NAME

REF.DRG.NO.

INVENTORY NO.

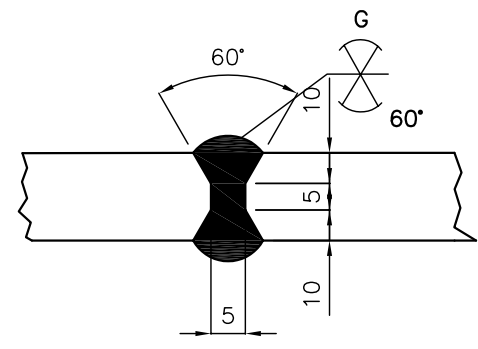

TYP.WELDING DET

01	FLANGE-I			PL32X1320X653	AA1011819171	77.000	
					AA10119		1
ITEM NO	DESCRIPTION	DRAWING NO.	VAR. NO.	RAW MATERIAL SIZE OR CASTING DRG.NO. OR FORGING DRG.NO.	MATERIAL CODE	NET WT.	GROSS WT.
					MATERIAL SPECN.	QUANTITY	

THE FOLLOWING CONDITIONS APPLY EXCEPT OTHERWISE STATED...

- REF.TO HY0230261 FOR UI TOLERANCES.
- CHAMFER M/CD SHARP ED 1.2 TO 1.0 AT 45°.
- INTERNAL M/CD CORNER RADII 1 TO 0.7.
- THE SURFACE ROUGHNESS WHEREVER NOT SHOWN SHALL BE TAKEN FROM THE SURFACE ROUGHNESS SHOWN OUT SIDE BACK SLASHES GIVEN AT THE TOP MOST RIGHT CORNER OF THE DRG.



TYPE OF PRODUCT OR NAME OF CUSTOMER/PROJECT
 BBD 4772 TUBE MILL

DRN.	NAME	SIGN.	DATE	NO.OF VAR.
CHD.	UMADEVI		9.11.07	
APPD.	PAVAN			
	T.M.R			

DEPT.	PULVE.ENGG	SCALE	1:14	WEIGHT (KG)	77.000	REF. TO ASSY DRG.	0-62-309-50581	ITEM NO.	09	NO.OF ITEMS	17
-------	------------	-------	------	-------------	--------	-------------------	----------------	----------	----	-------------	----

TITLE	FLANGE-1 (REFUSAL BOX)	DRAWING NO.	3-62-309-50359	REV.	01
SHEET NO.	01	NO OF SHEETS	01		

REV.	DATE	ALTERED	REV.	DATE	ALTERED
		CHD. PAVAN	01	23.3.10	SATISH
		APPD. TMR			
ZONE			ZONE		RAW MATL CHANGED FROM PL25 TO 32. RAW MATL SIZES CHANGED.

24-03-2010 15:25:58

This Drawing is printed from Engineering Digital Archive System (EAS) Therefore signatures are not essentially required.

(ALL DIMENSIONS ARE IN mm)

FIRST ANGLE PROJECTION

793440/2022/FSIP-R&D_UNIT

DRG.NO. 3-62-309-50382

THE INFORMATION ON THIS DOCUMENT IS THE PROPERTY OF BHARAT HEAVY ELECTRICALS LTD. IT MUST NOT BE USED DIRECTLY OR INDIRECTLY IN ANY WAY DETRIMENTAL TO THE INTEREST OF THE COMPANY.

36250382 FILE NAME

REF.DRG.NO.

INVENTORY NO.

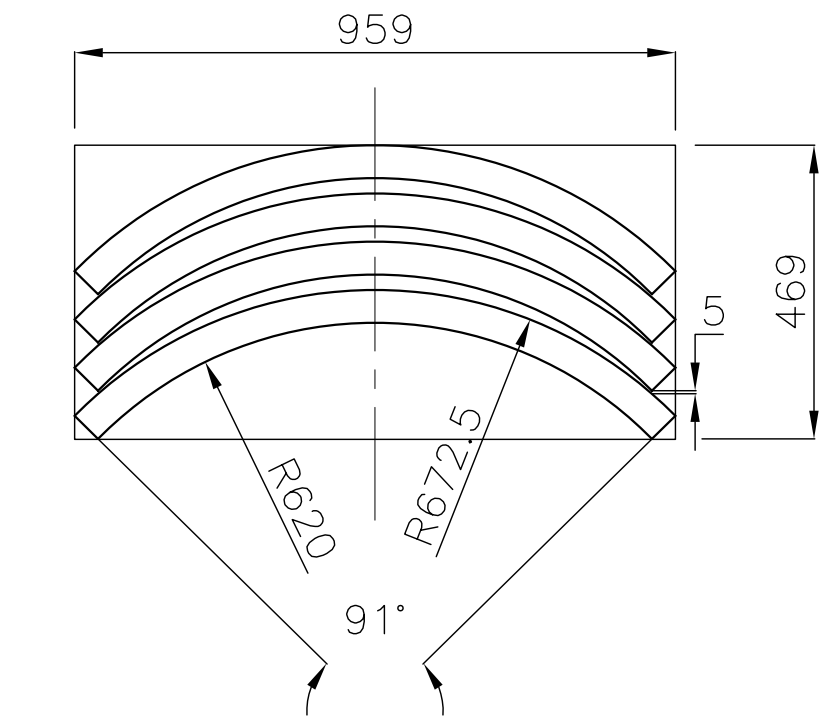
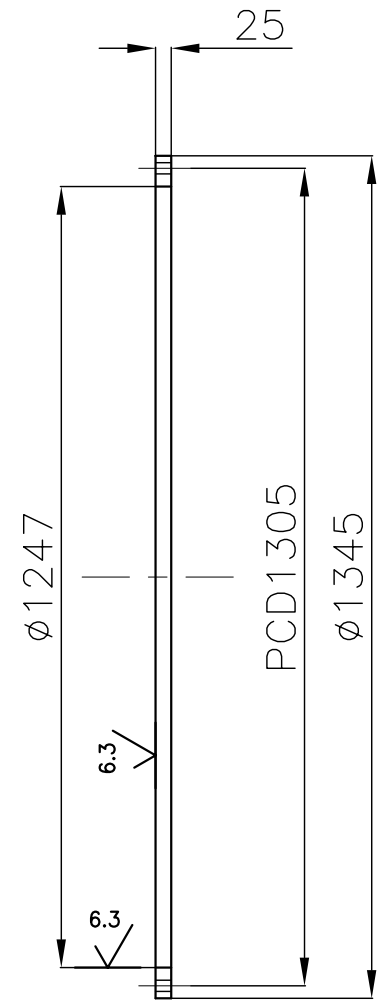
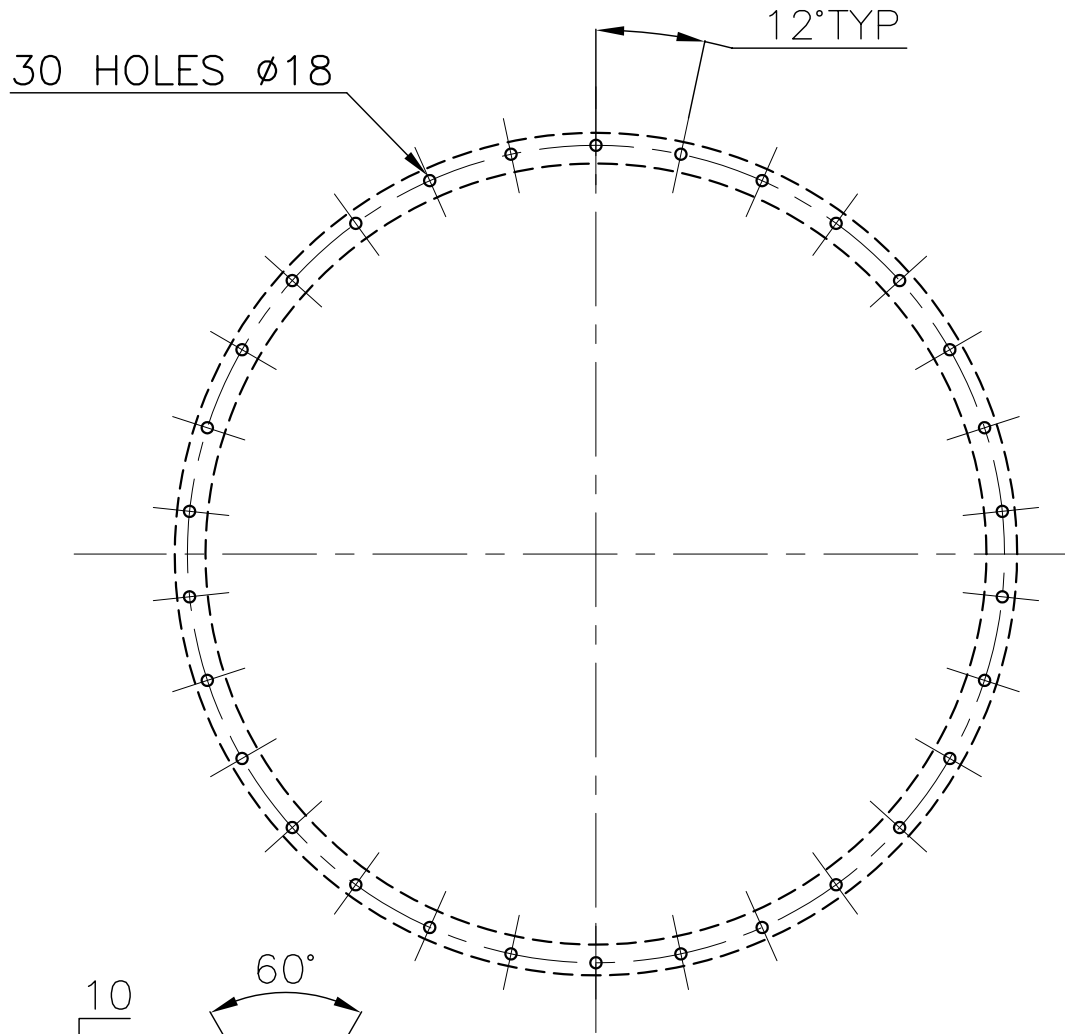

CUTTING PLAN INCLUDING CUTTING ALLOWANCE

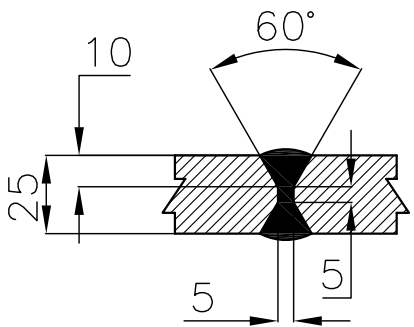

TYP.WELDING DETAIL

1	PLATE			PL.32X960X470	AA1011819171	37.60
					AA10119	1
ITEM NO	DESCRIPTION	DRAWING NO.	VAR. NO.	RAW MATERIAL SIZE OR CASTING DRG.NO. OR FORGING DRG.NO.	MATERIAL CODE	NET WT. GROSS WT.
					MATERIAL SPECN.	QUANTITY

NOTE

GENERAL DIMENSIONS LIMITS FITS AND TOLERANCES AS PER P.S.HY 0230261

THE FOLLOWING CONDITIONS APPLY EXCEPT OTHERWISE STATED...

- REF.TO HY0230261 FOR UI TOLERANCES.
- CHAMFER M/CD SHARP ED 1.2 TO 1.0 AT 45°.
- INTERNAL M/CD CORNER RADII 1 TO 0.7.
- THE SURFACE ROUGHNESS WHEREVER NOT SHOWN SHALL BE TAKEN FROM THE SURFACE ROUGHNESS SHOWN OUT SIDE BACK SLASHES GIVEN AT THE TOP MOST RIGHT CORNER OF THE DRG.



TYPE OF PRODUCT OR NAME OF CUSTOMER/PROJECT **BBD 4772 TUBE MILL**

BHARAT HEAVY ELECTRICALS LTD. HYDERABAD	DRN.	NAME	SIGNATURE	DATE	NO.OF VAR.	
	CHD.	RAZVI		13.2.07		
	APPD.	N.D.SAMUEL		13.2.07		
DEPT.	PULVE.ENGG	SCALE	WEIGHT (KG)	REF. TO ASSY DRG.	ITEM NO.	NO.OF ITEMS
CODE	446	1:15	37.60	0.62.309.50581	10	17
TITLE			DRAWING NO.		REV.	
FLANGE-II (REFUSAL BOX)			3-62-309-50382		03	
			SHEET NO. 01	NO OF SHEETS 01		

REV. 03	DATE 23.3.10	ALTERED CHD. PAVAN	SATISH	APPD. T.M.RAO	REV. 02	DATE 13.2.07	ALTERED CHD. N.D.S	RAZVI	APPD. T.M.RAO
ZONE	RAW MATL SIZE CHANGED				ZONE	DRAWING REDRAWN PL.DIM WAS 1090X630.			

24-03-2010 15:27:52

This Drawing is printed from Engineering Digital Archive System (EAS) Therefore signatures are not essentially required.

(ALL DIMENSIONS ARE IN mm)

FIRST ANGLE PROJECTION

793440/2022/ESIP-R&D_UNIT

DRG.NO. 3-62-309-50532

THE INFORMATION ON THIS DOCUMENT IS THE PROPERTY OF BHARAT HEAVY ELECTRICALS LTD. IT MUST NOT BE USED DIRECTLY OR INDIRECTLY IN ANY WAY DETRIMENTAL TO THE INTEREST OF THE COMPANY.

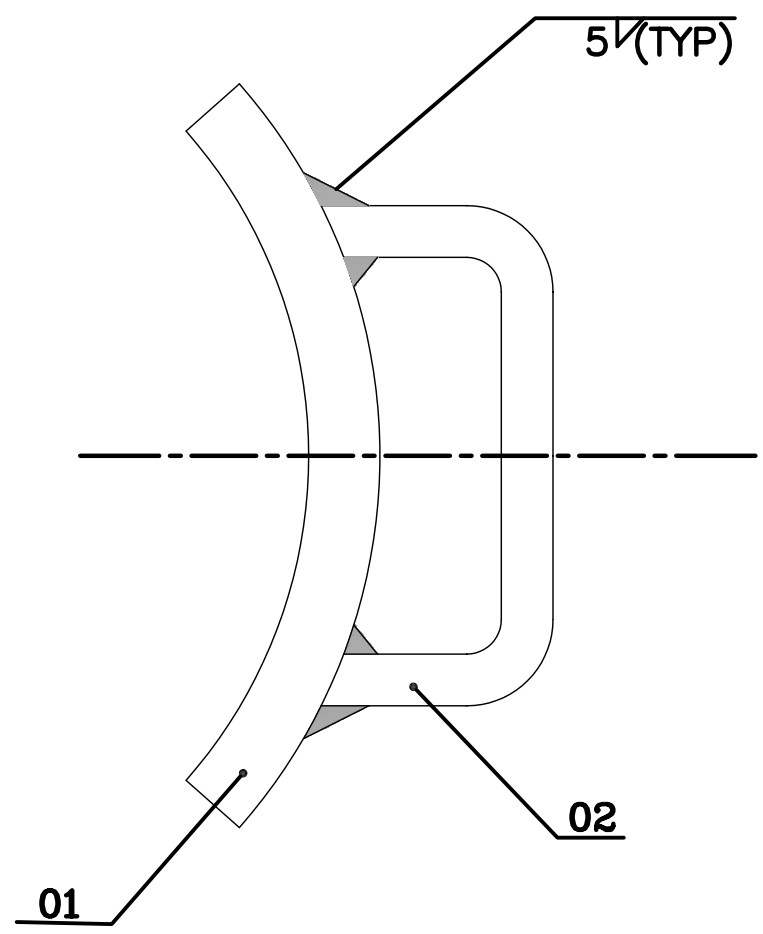

36250532

FILE NAME

REF.DRG.NO.

INVENTORY NO.

ITEM NO	DESCRIPTION	DRAWING NO.	VAR. NO.	RAW MATERIAL SIZE OR CASTING DRG.NO. OR FORGING DRG.NO.	MATERIAL CODE	NET WT.	GROSS WT.
					MATERIAL SPECN.	QUANTITY	
02	HANDLE			4-62-508-50334		0.15	
01	DOOR PLATE			4-62-309-50698		12.0	
							1
							1

THE FOLLOWING CONDITIONS APPLY EXCEPT OTHERWISE STATED...

- REF.TO HY0230261 FOR UNIFORM TOLERANCES.
- CHAMFER M/CD SHARP EDG 1.2 TO 1.0 AT 45°.
- INTERNAL M/CD CORNER RADII 1 TO 0.7.
- THE SURFACE ROUGHNESS WHEREVER NOT SHOWN SHALL BE TAKEN FROM THE SURFACE ROUGHNESS SHOWN OUT SIDE BACK SLASHES GIVEN AT THE TOP MOST RIGHT CORNER OF THE DRG.



TYPE OF PRODUCT OR NAME OF CUSTOMER/PROJECT **BBD 4742 TUBE MILL**

	NAME	SIGNATURE	DATE	NO.OF VAR.
DRN.	JOSEPH		15-10-07	
CHD.	PAVAN		15-10-07	
APPD.	T.M.R		15-10-07	

DEPT. PULVE.ENGG	SCALE N.T.S	WEIGHT (KG) 12.15	REF. TO ASSY DRG. 0-62-309-50581	ITEM NO. 19	NO.OF ITEMS 21
CODE 446	TITLE DOOR COVER ASSY (REFUSAL BOX)		DRAWING NO. 3-62-309-50532	REV. 00	
			SHEET NO. 01	NO OF SHEETS 01	

RESTRICTED USE

09-05-2008 14:34:27

This Drawing is printed from Engineering Digital Archive System (EDAS) Therefore signatures are not essentially required.

REV. DATE	ALTERED	REV. DATE	ALTERED	REV. DATE	ALTERED
01 25.3.10	SATISH				
	CHECKED PAVAN		CHECKED		CHECKED
	APPROVED TMR		APPROVED		APPROVED

DRG REDRAWN

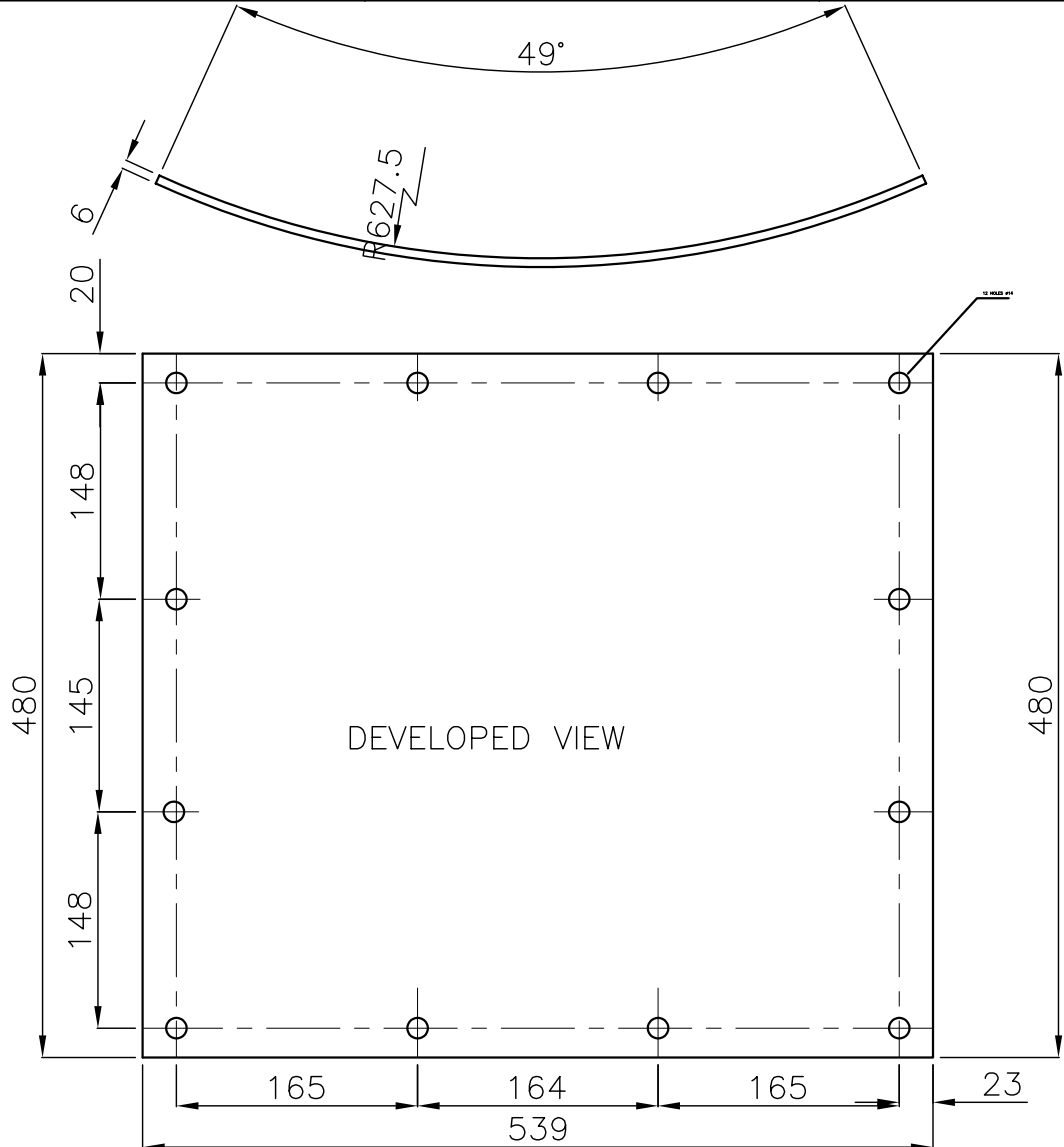

THE INFORMATION ON THIS DOCUMENT IS THE PROPERTY OF BHARAT HEAVY ELECTRICALS LIMITED. IT MUST NOT BE USED DIRECTLY OR INDIRECTLY IN ANY WAY DETRIMENTAL TO THE INTEREST OF THE COMPANY.

DOOR PLATE	PL 8X480X539	AA1011808056	12.00	12.00
		AA10108		1

DESCRIPTION & DRG.NO.	VAR NO.	RAW MATERIAL SIZE OR CASTING DRG.NO. OR FORGING DRG.NO.	MATL. CODE	NET.WT.	GROSS WT
			MATL. SPECN.	QTY.	

TYPE OF PRODUCT OR NAME OF CUSTOMER/PROJECT: BBD 4772 TUBE MILLS



BHARAT HEAVY ELECTRICALS LTD. HYDERABAD	DRN.	Phani	SIGN	DATE	NO.OF VAR.
	CKD.	B.Pavan kumar	RESTRICTED USE	22.2.06	
	APPD.	T.Mohan R		22.6.06	

DEPT. PULV.ENGG	SCALE 1:5	WEIGHT(K.G.)	REF.TO ASSY.DRG.	ITEM NO.	NO.OF ITEM
CODE 446		12.00	3-62-309-50532	01	02
TITLE DOOR PLATE (REFUSAL BOX)			DRAWING NO.	REV.	
			4-62-309-50698	01	
			SHT.NO. 01	NO.OF SHT. 01	

INVENTORY NO. REF. TO HY0230. UNSPECIFIED TOL

THE INFORMATION ON THIS DOCUMENT IS THE PROPERTY OF BHARAT HEAVY ELECTRICALS LIMITED. IT MUST NOT BE USED DIRECTLY OR INDIRECTLY IN ANY WAY DETRIMENTAL TO THE INTEREST OF THE COMPANY.

REV. DATE	ALTERED	Yadagiri	REV. DATE	ALTERED	REV. DATE	ALTERED
02	20.04.00	CHECKED B.Pavan kumar		CHECKED		CHECKED
		APPROVED G.Kistaiah		APPROVED		APPROVED

DRAWN IN AUTOCAD
WITH PREVIOUS CHANGES

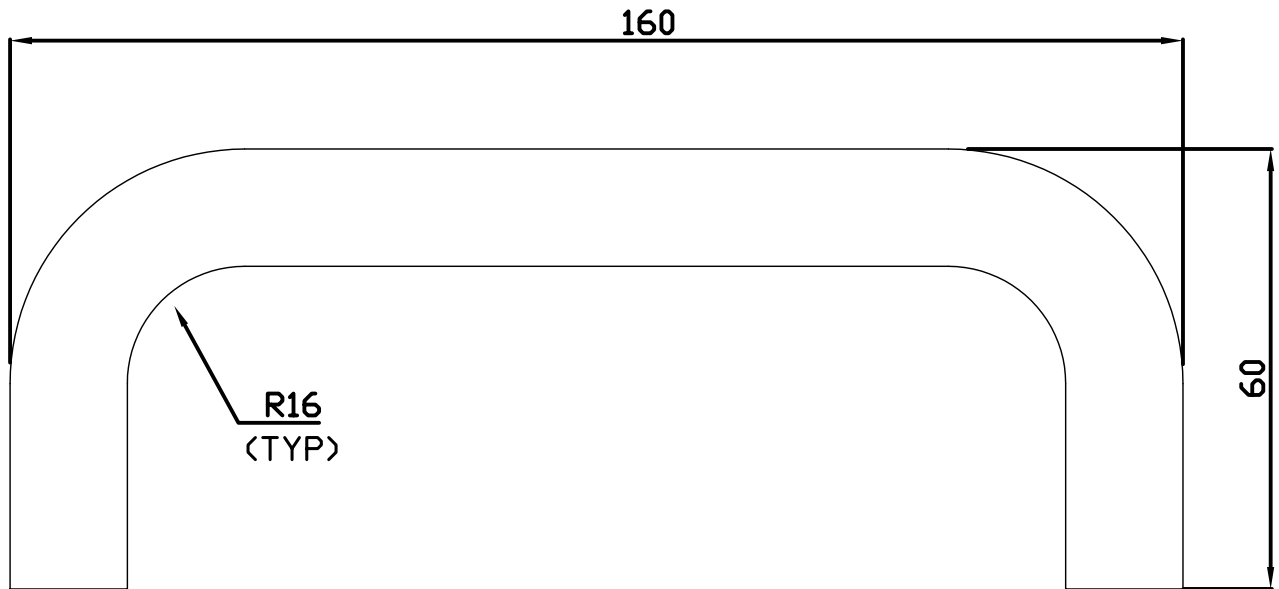

NOTE: DEBURR ALL SHARP EDGES

COMPUTER NO. 46250334.DWG	ROUND		Ø16X238LG	HY1010299085	0.36	
REF. DRG. NO.	DESCRIPTION & DRG.NO.	VAR. NO.	RAW MATERIAL SIZE OR CASTING DRG.NO. OR FORGING DRG.NO.	MATL. CODE	NET.WT.	GROSS WT
				MATL. SPECN.	QTY.	
INVENTORY NO.	REF. TO HY0230 UNSPECIFIED TO	BBD 3448/4760/4772 TUBE MILLS				

		BHARAT HEAVY ELECTRICALS LTD. HYDERABAD		DRN.	Yadagiri	SIGN		DATE	18.04.00	NO.OF VAR.
		CKD.	B.Pavan kumar			18.04.00				
		APPD.	G.Kistaiah			18.04.00				
DEPT. PULV.ENGG	CODE 446		SCALE 1:1	WEIGHT(K.G.) 0.45	REF.TO ASSY.DRG. 3.62.508.50284	ITEM NO. 2	NO.OF ITEM -	DRAWING NO. 4-62-508-50334		REV. 02
TITLE HANDLE					SHT.NO. 01	NO.OF SHT. 01				