

ALL DIMENSIONS ARE IN MM

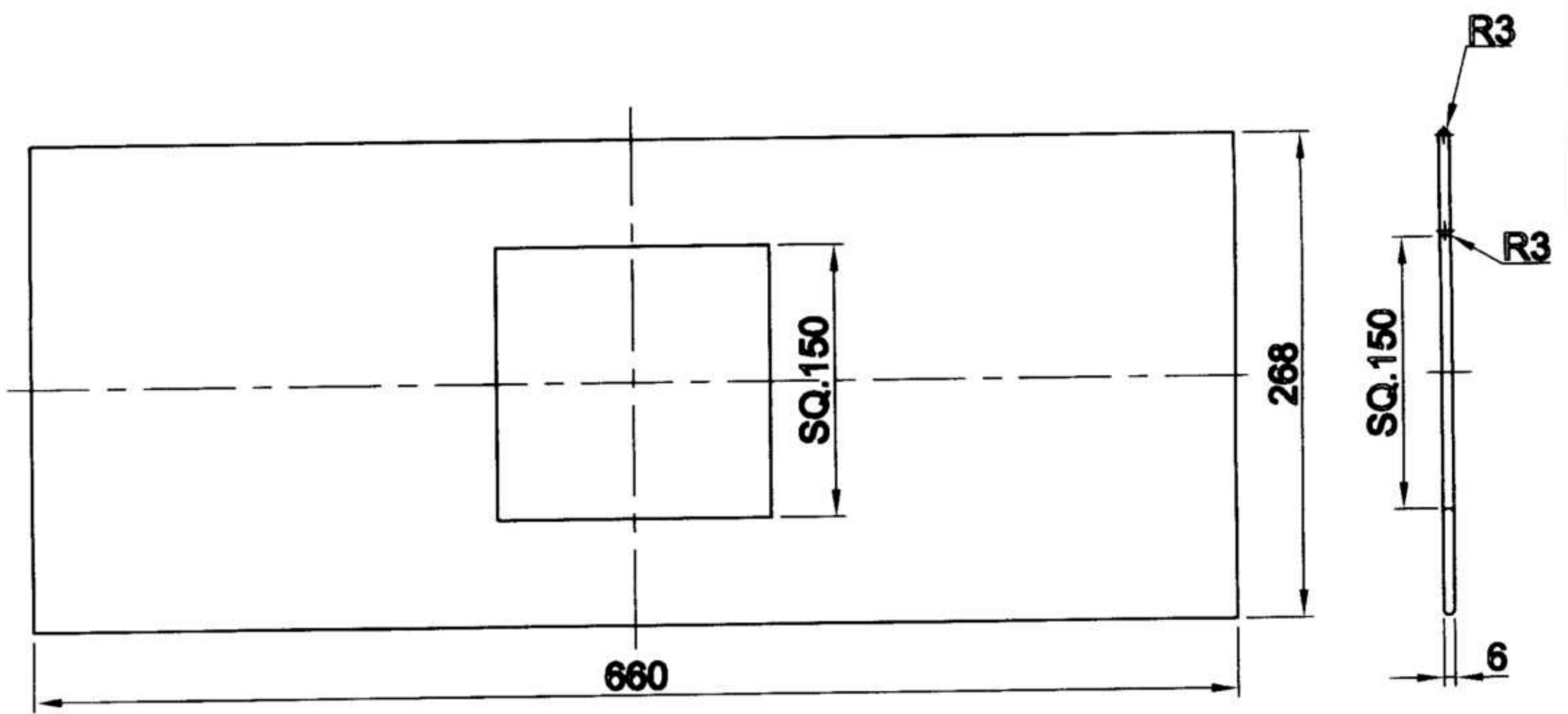

CAUTION: THE INFORMATION ON THIS DOCUMENT IS THE PROPERTY OF BHARAT HEAVY ELECTRICALS LTD
IT MUST NOT BE USED DIRECTLY OR INDIRECTLY IN ANYWAY DETERMINANT TO INTEREST OF THE COMPANY

REV 01	DATE	ALTERED
		CHECKED
		APPROVED

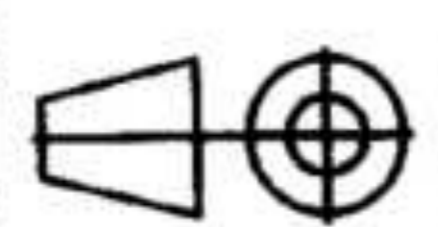

NOTES:-

1. ALL SHARP CORNERS ARE TO BE ROUNDED R3.WHERE NOT SPECIFIED WHERE NOT SPECIFIED
2. WEIGHT VARIATION ±5%
3. WARPAGE NOT TO EXCEED 3 TO 5mm IN ANY DIRECTION.

				HN Alloy (Grade-11 IS-4522)		
ITEM NO	DESCRIPTION	DRAWING NO	MATL CODE		UNIT WT	
			MATL SPEC		QTY	
EQPT: WALKING BEAM FURNACE						
 Bharat Heavy Electricals Ltd SEAMLESS STEEL TUBE PLANT TIRUCHIRAPALLI - 620014		DRN	NAME SSN.KUMAR	SIGNATURE <i>S.S.N. Kumar</i>	DATE 15.12.04	
		CHD				
		APPD	S.SHANMUGASUNDARAM	<i>S. Shanmugasundaram</i>	16/12/06	
DEPT MPG	GRADE OF UNTOL. DIM <i>Q/M/P</i>		SCALE 1:5	WEIGHT (Kg) 8.3	REF TO ASSY DRG	ITEM NO
CODE					REF TO OLD DRG FA-0428-9A	
TITLE HEARTH TOP SEAL CASTING				CARD CODE U 01	DRAWING NO : 4-7-1150-02-06290	REV 00

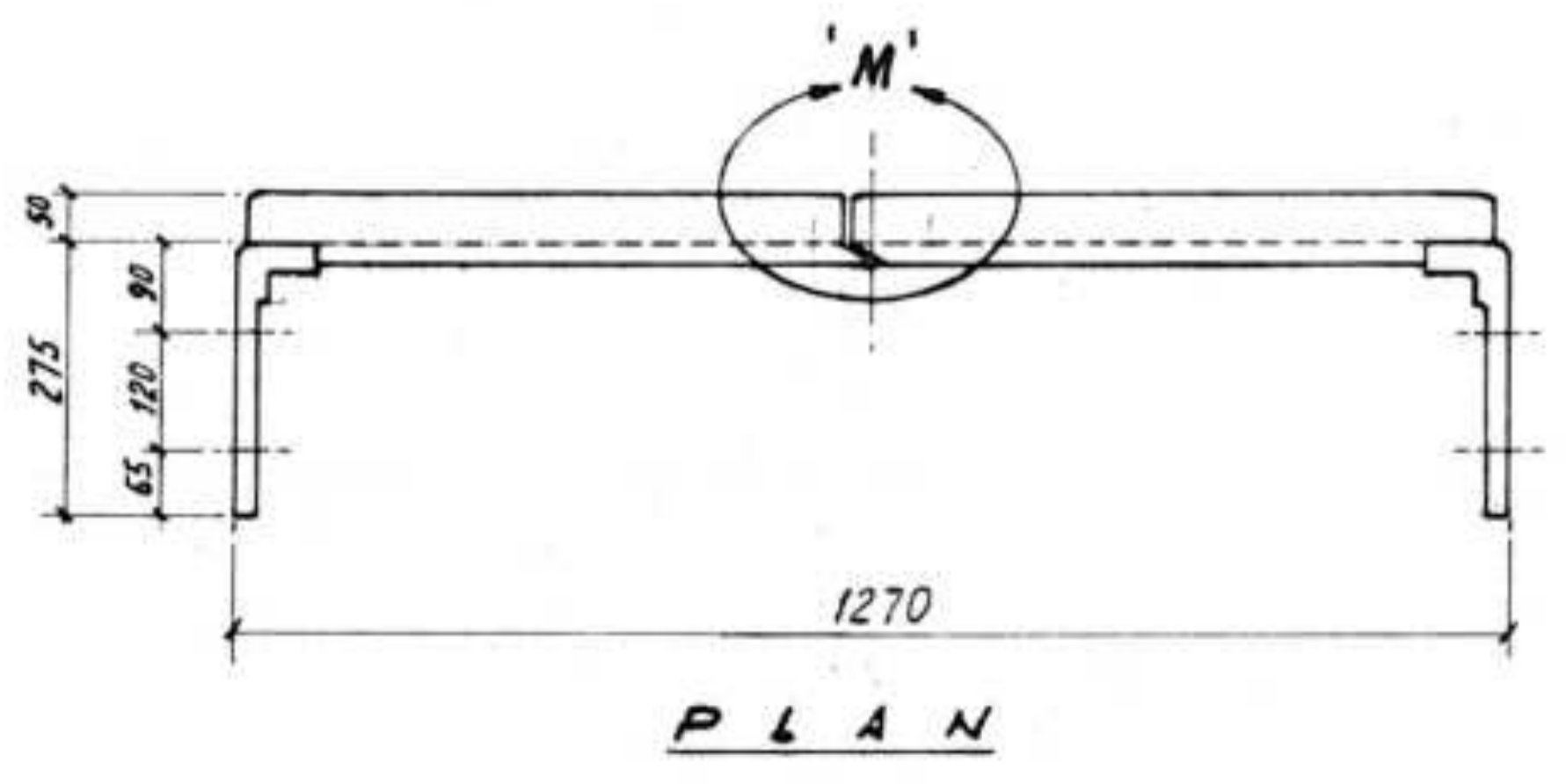
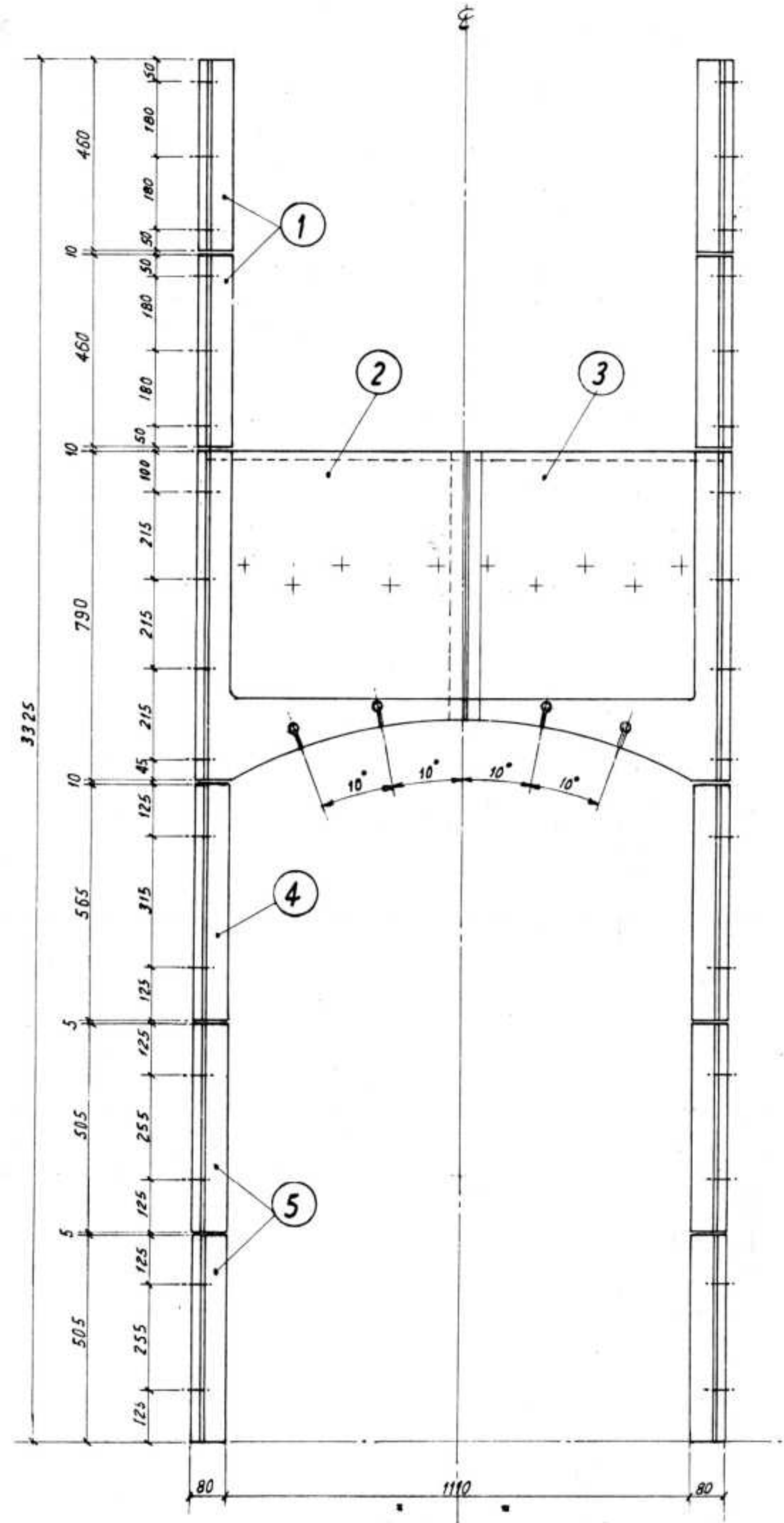

ASSEMBLY FOR CHARGE & DISCH. DOOR FRONT PLATE
2 SETS REQUIRED

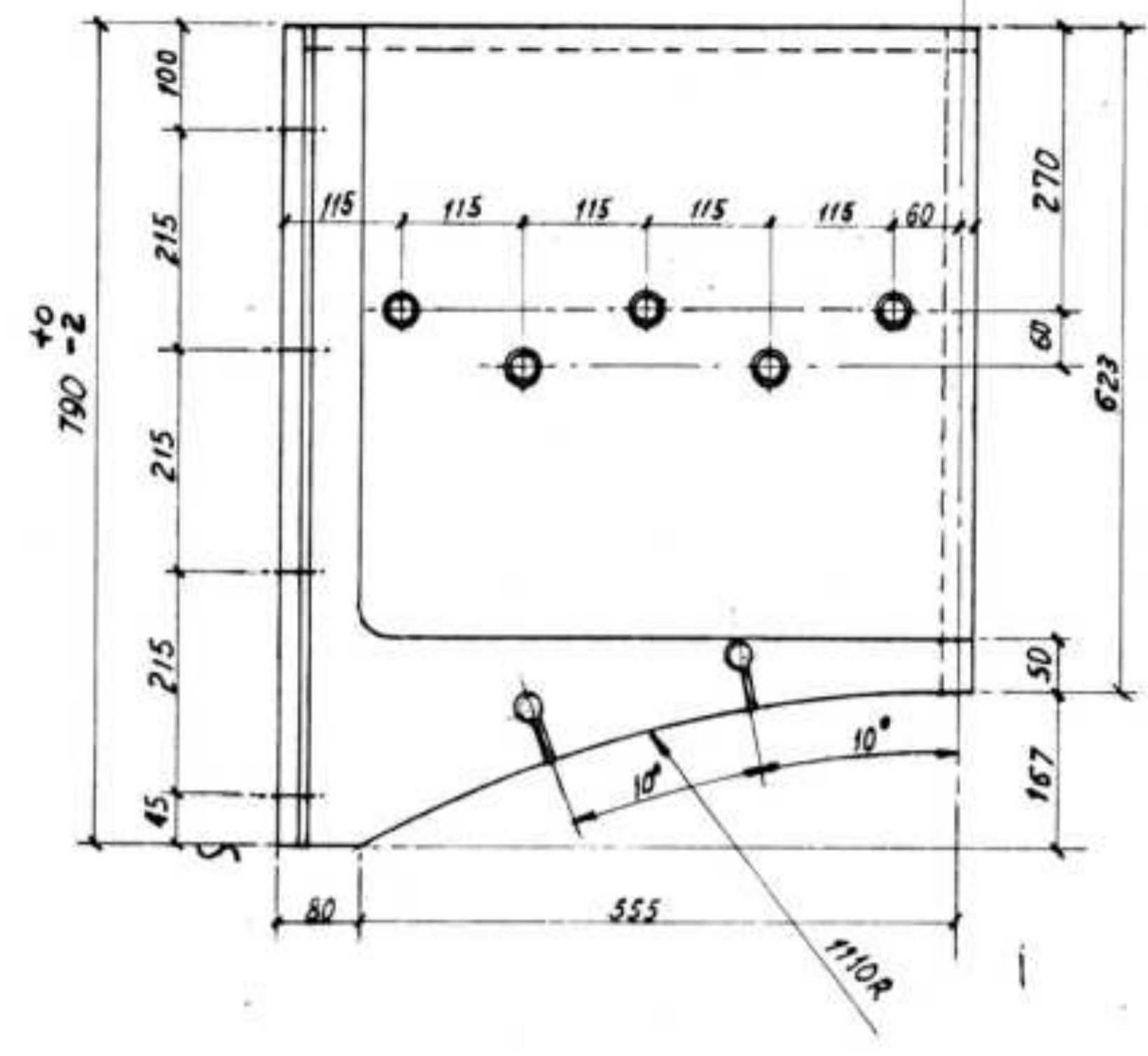

2 DOOR FRONT PLATE CASTING
Matl-HN Alloy(grade-11 IS-4522)
QTY. - 2 Nos.

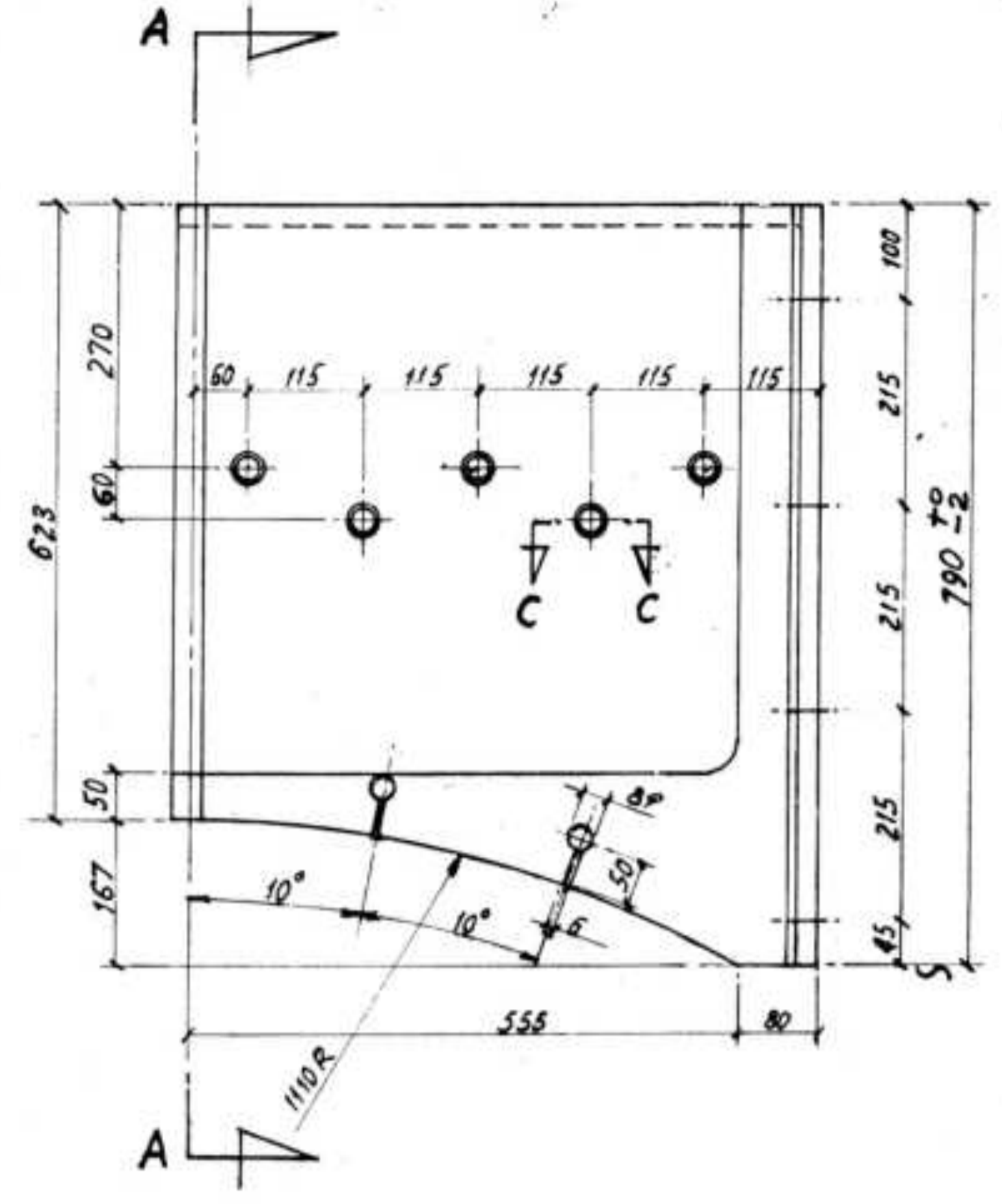

3 DOOR FRONT PLATE CASTING
Matl-HN Alloy(grade-11 IS-4522)
QTY. - 2 Nos.

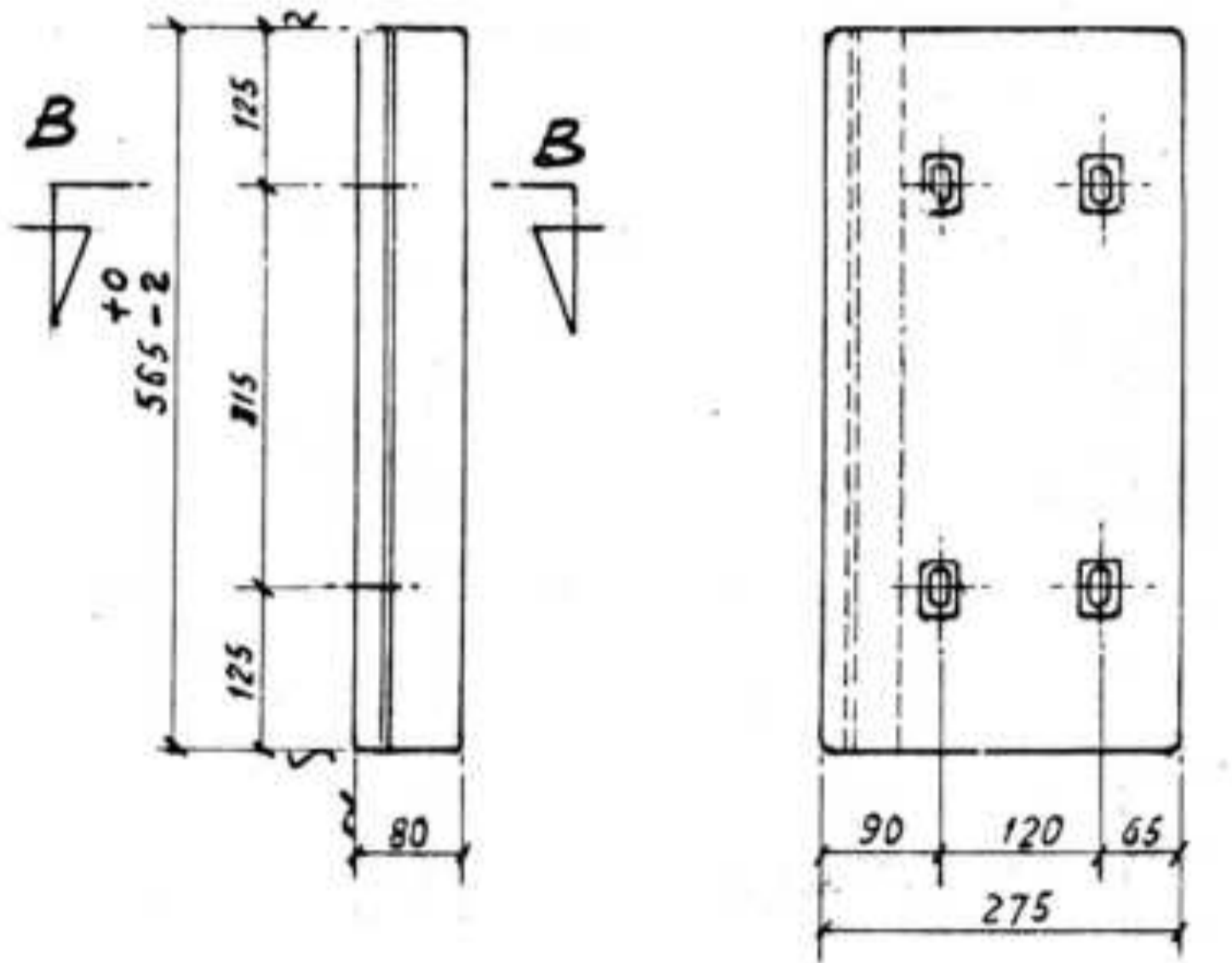

4 DOOR FRONT PLATE CASTING
MATL. - HK ALLOY (25% Cr. 20% Ni)
WT./PIECE = 27.4 KG.
QTY. - 4 Nos.

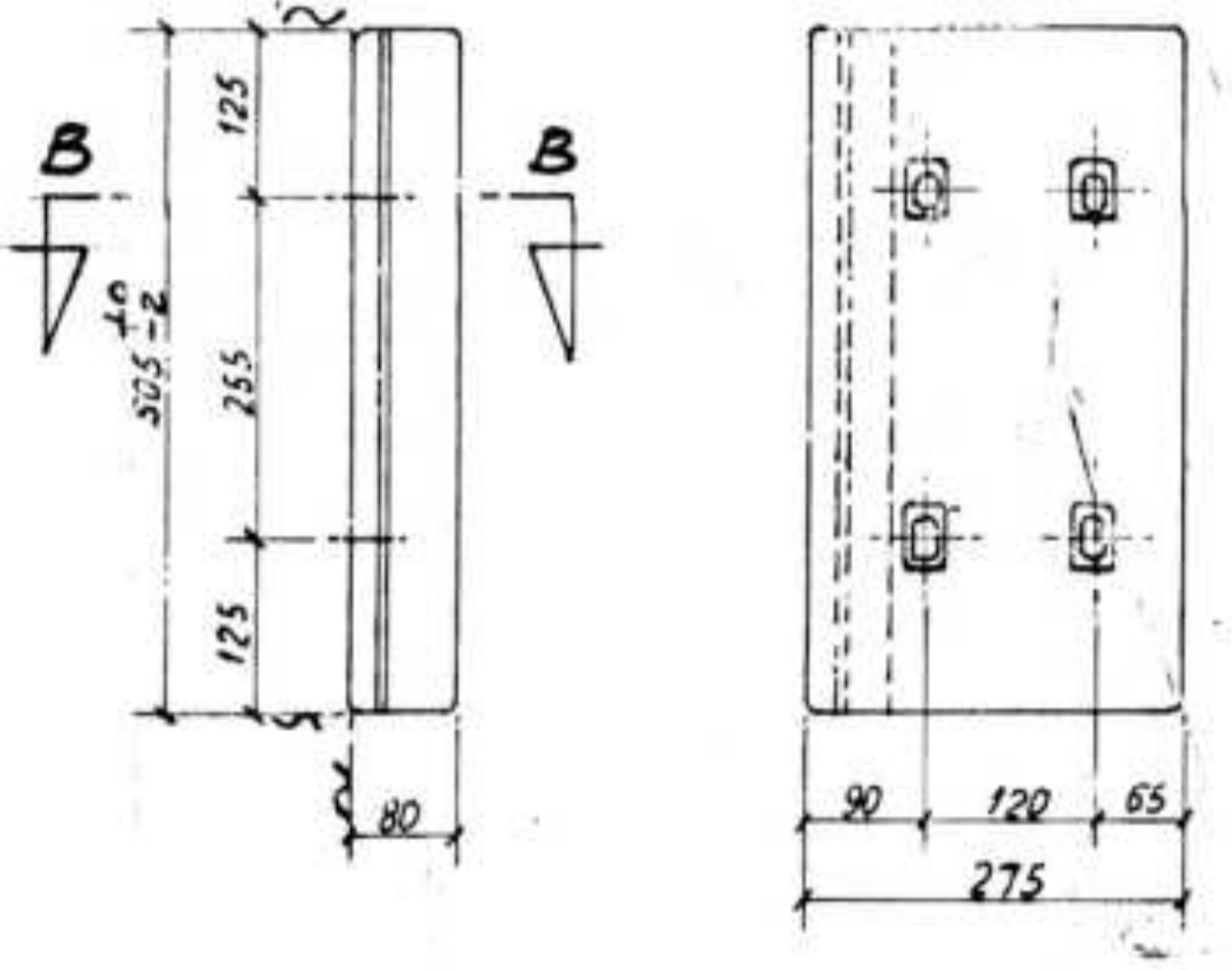

5 DOOR FRONT PLATE CASTING
MATL. - HK ALLOY (25% Cr. 20% Ni)
WT./PIECE = 30.7 KG.
QTY. - 8 Nos.

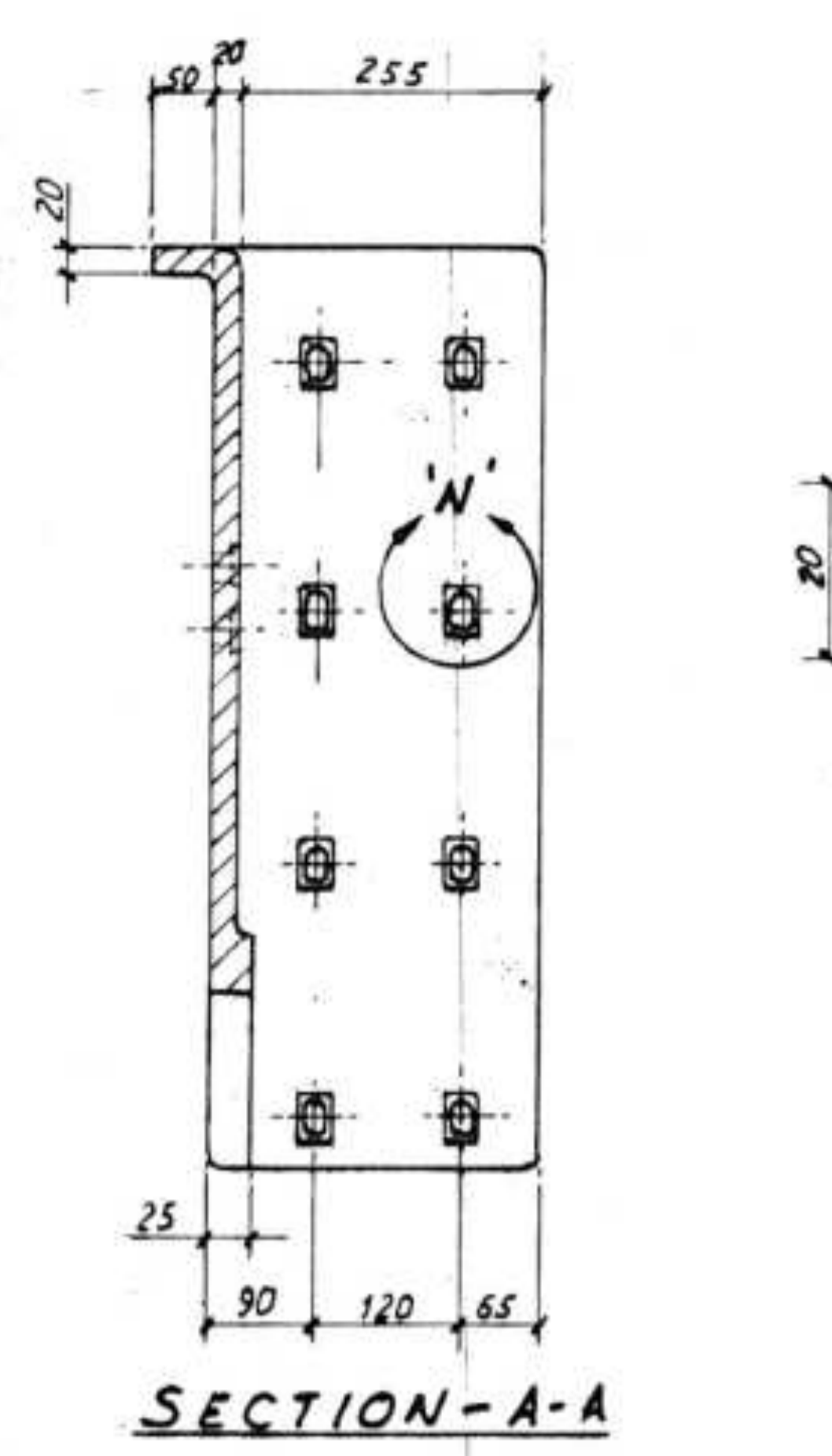

ENLGD. SECTION - C-C
(TYPICAL)

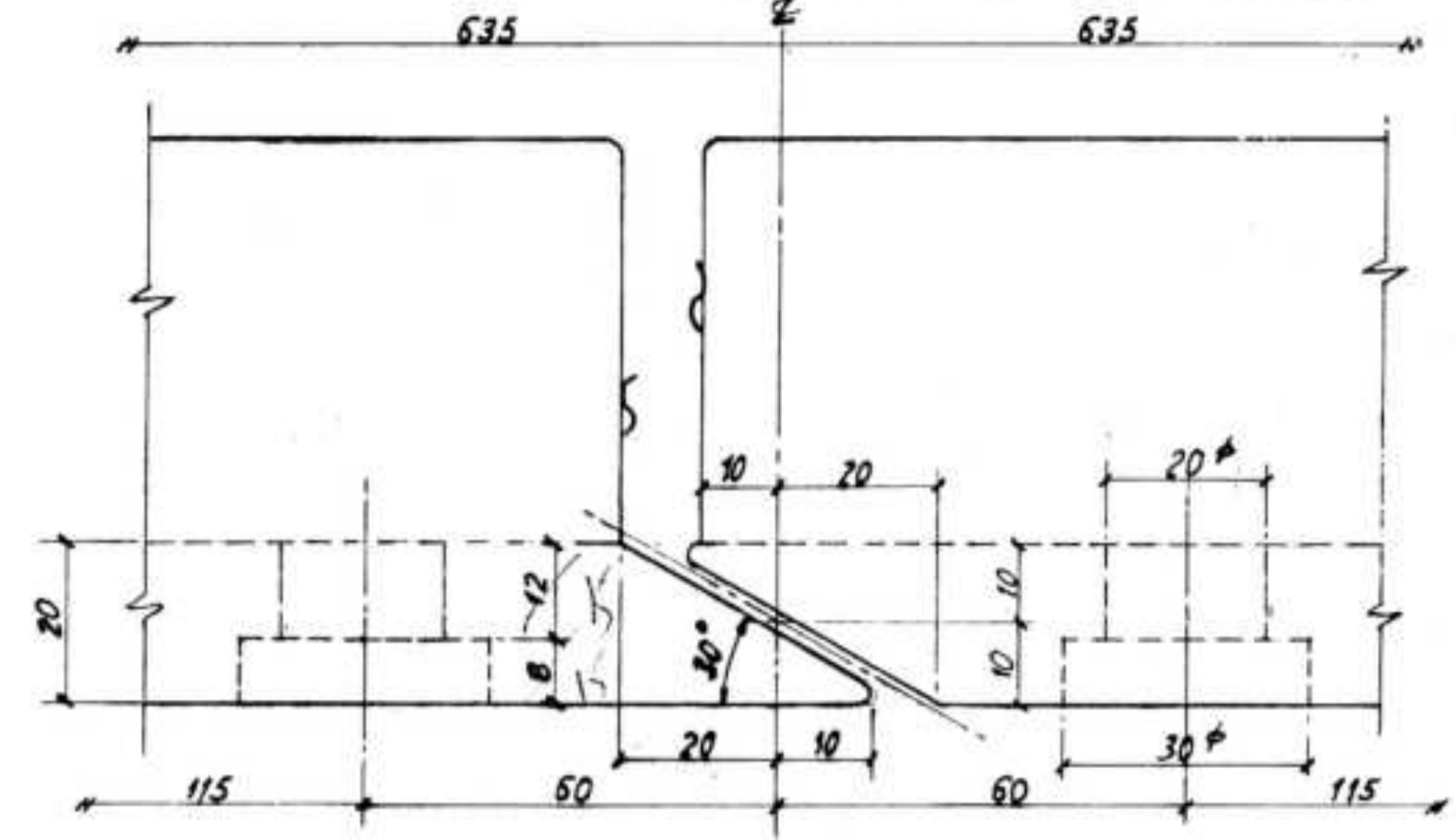

ENLGD. DETAIL - 'M'

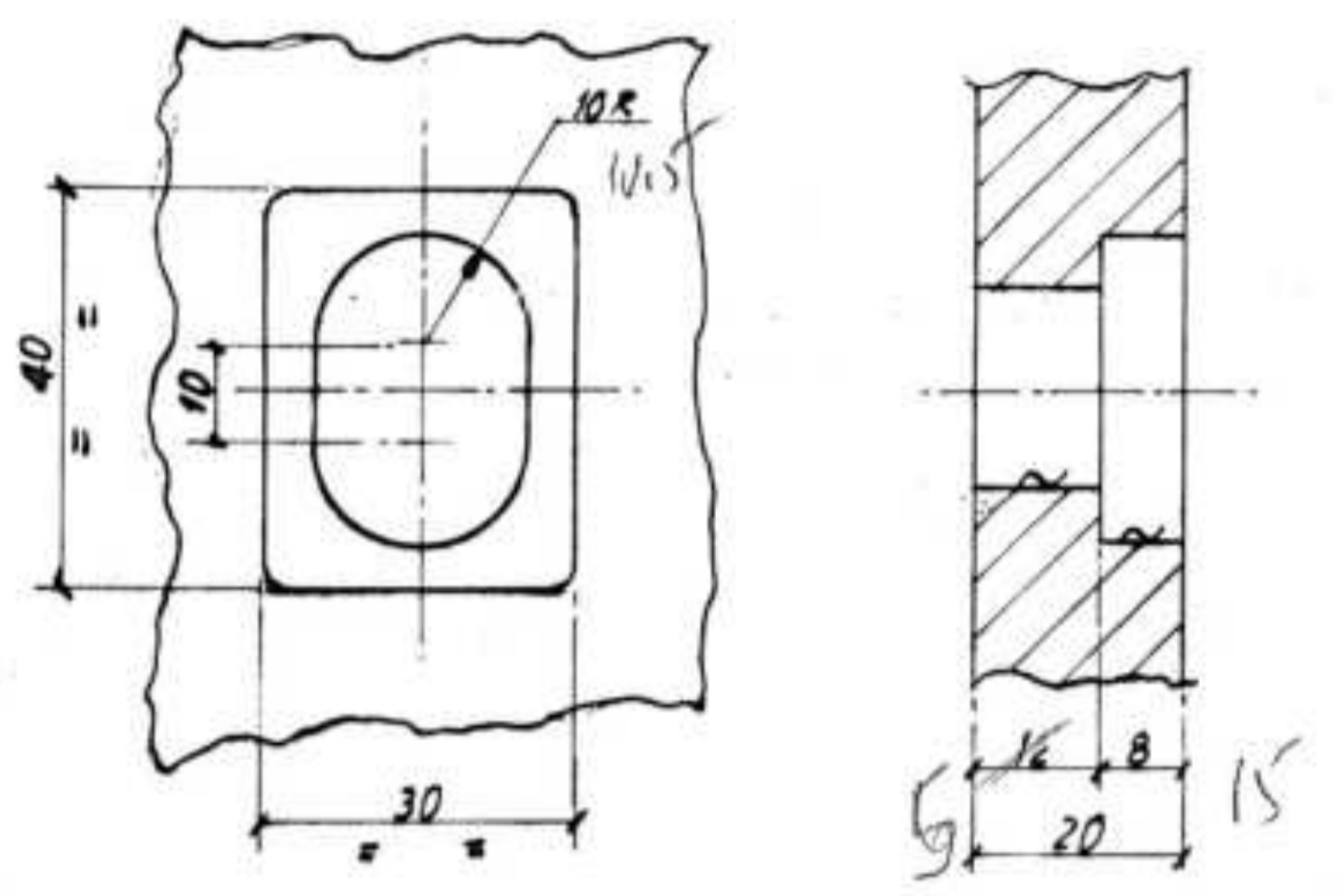

ENLGD. DETAIL - 'N'
(TYPICAL)

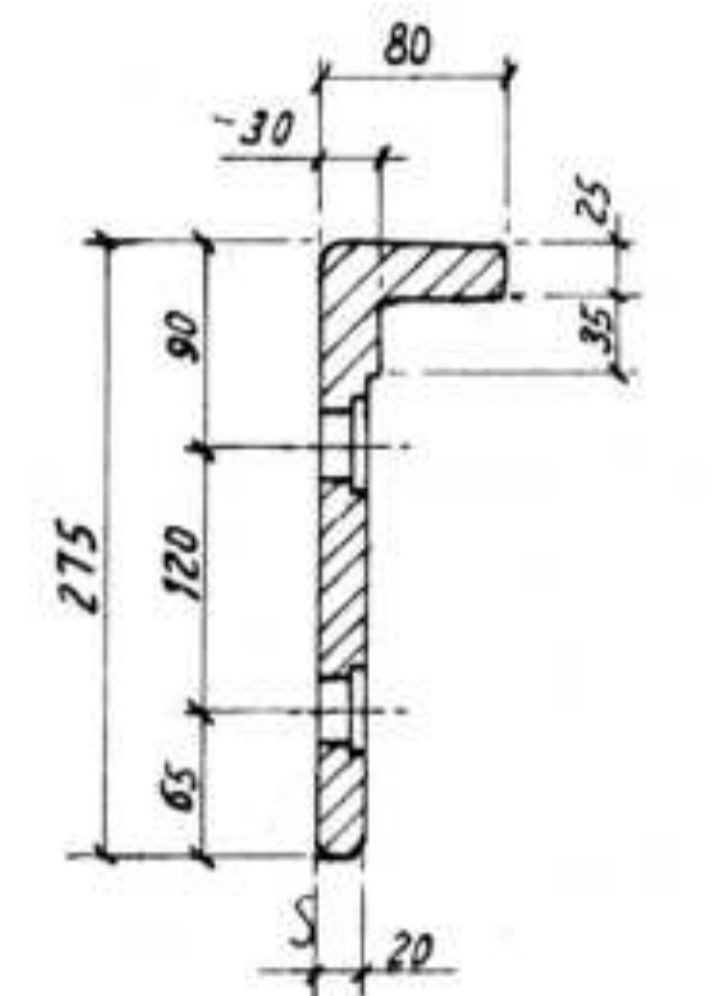

ENLGD. SECTION - B-B

- NOTES:-
- CASTINGS TO BE MADE STRAIGHT, SMOOTH, TRUE TO DIMENSIONS AND FREE FROM FINS, SCABS, BLOWHOLES & COLD SHOTS.
 - SURFACES TO BE FINISHED SMOOTH BY SHOT BLASTING OR GRINDING
 - ALL CORNERS TO BE 5MM RADII UNLESS STATED OTHERWISE.
 - DENOTES GRINDING ~

REV	DATE	ALTY	CHK	ID

EQPT: ROTARY HEARTH FURNACE

SHARAT HEAVY ELECTRICALS LIMITED,
SEAMLESS STEEL TUBE PLANT- TIRUCHIRAPALLI-620 014

DPT. CODE: S5TP 456 SCALE: 1:10 WEIGHT (Kg): REF TO: FA-0427-9

TITLE: CHARGE & DISCHARGE DOOR FRONT PLATE CASTING ARRGT. & DETAILS

DIMENSIONS TO BE CONTROLLED WITHIN LIMITS AS SHOWN. MACHINING TOLERANCE: 0.25MM UNLESS OTHERWISE SHOWN. NON-MACHINING TOLERANCE: 0.5MM

DRAWING No: 1-7-1101-07-01699

SHEET No: 60

APPROVED: R.R. Prabhakar

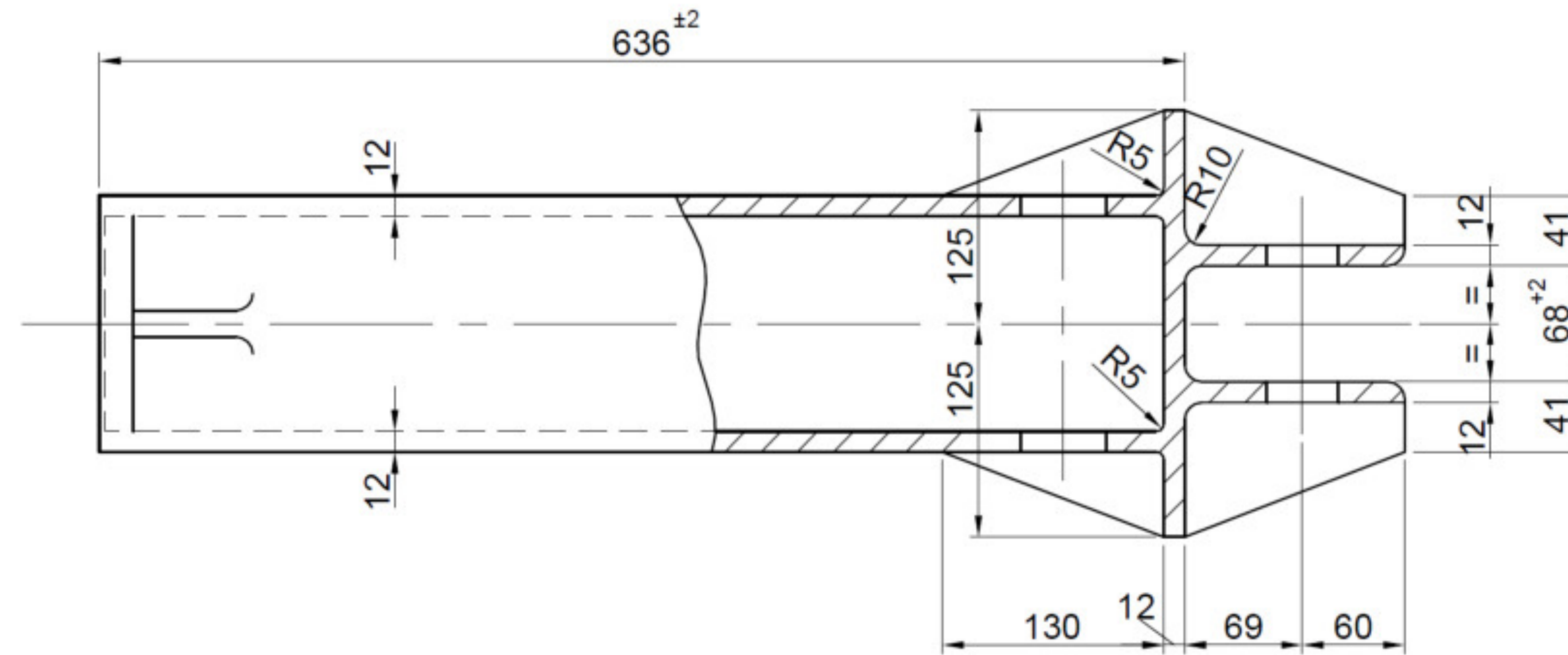
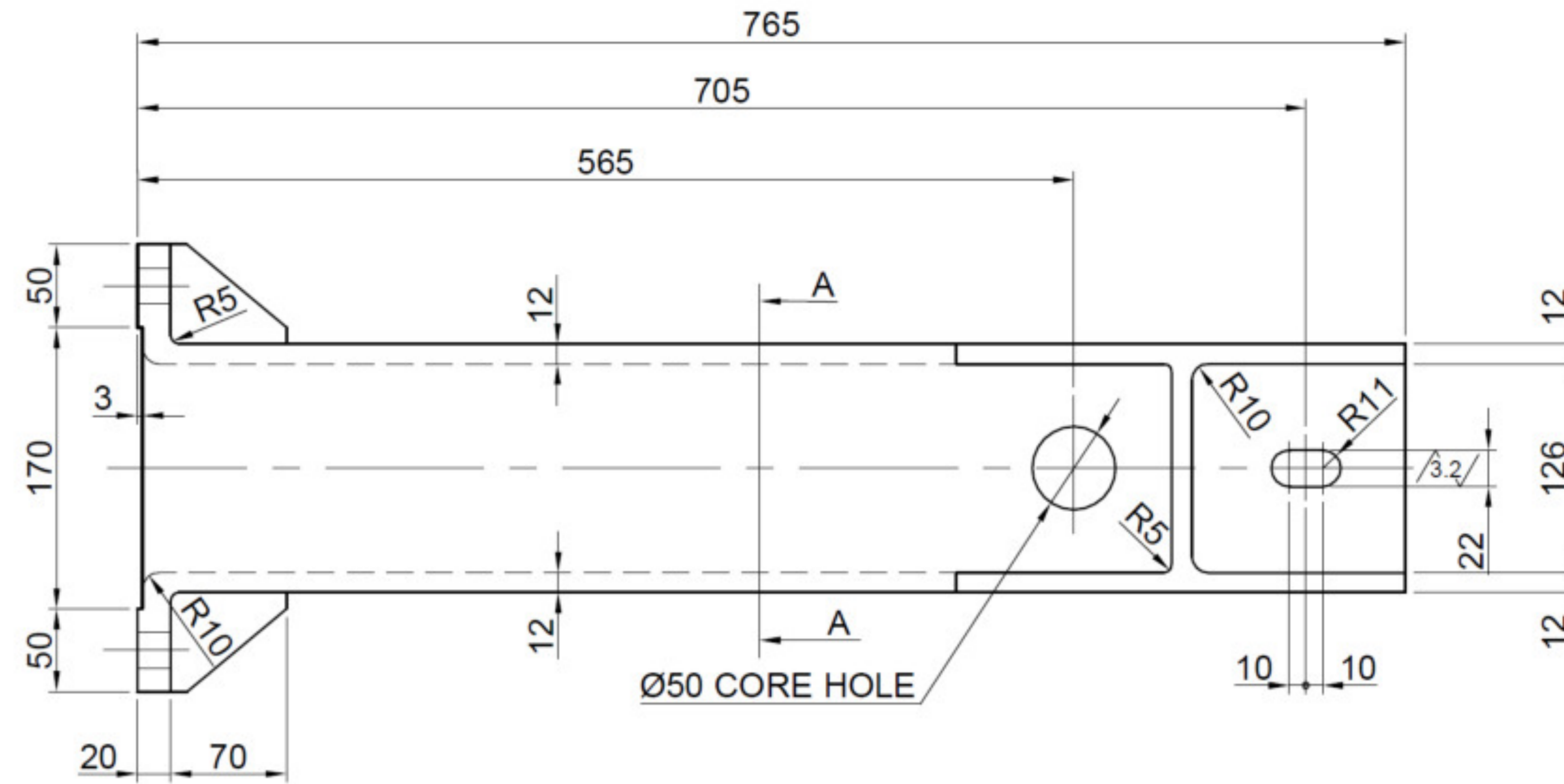
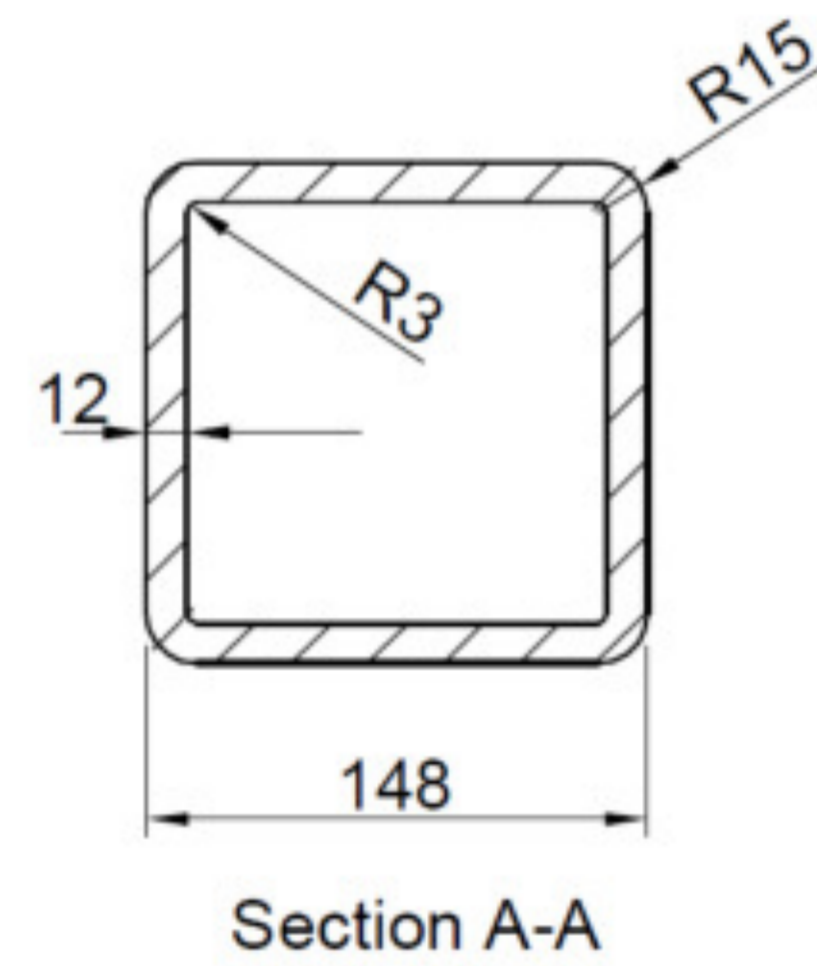
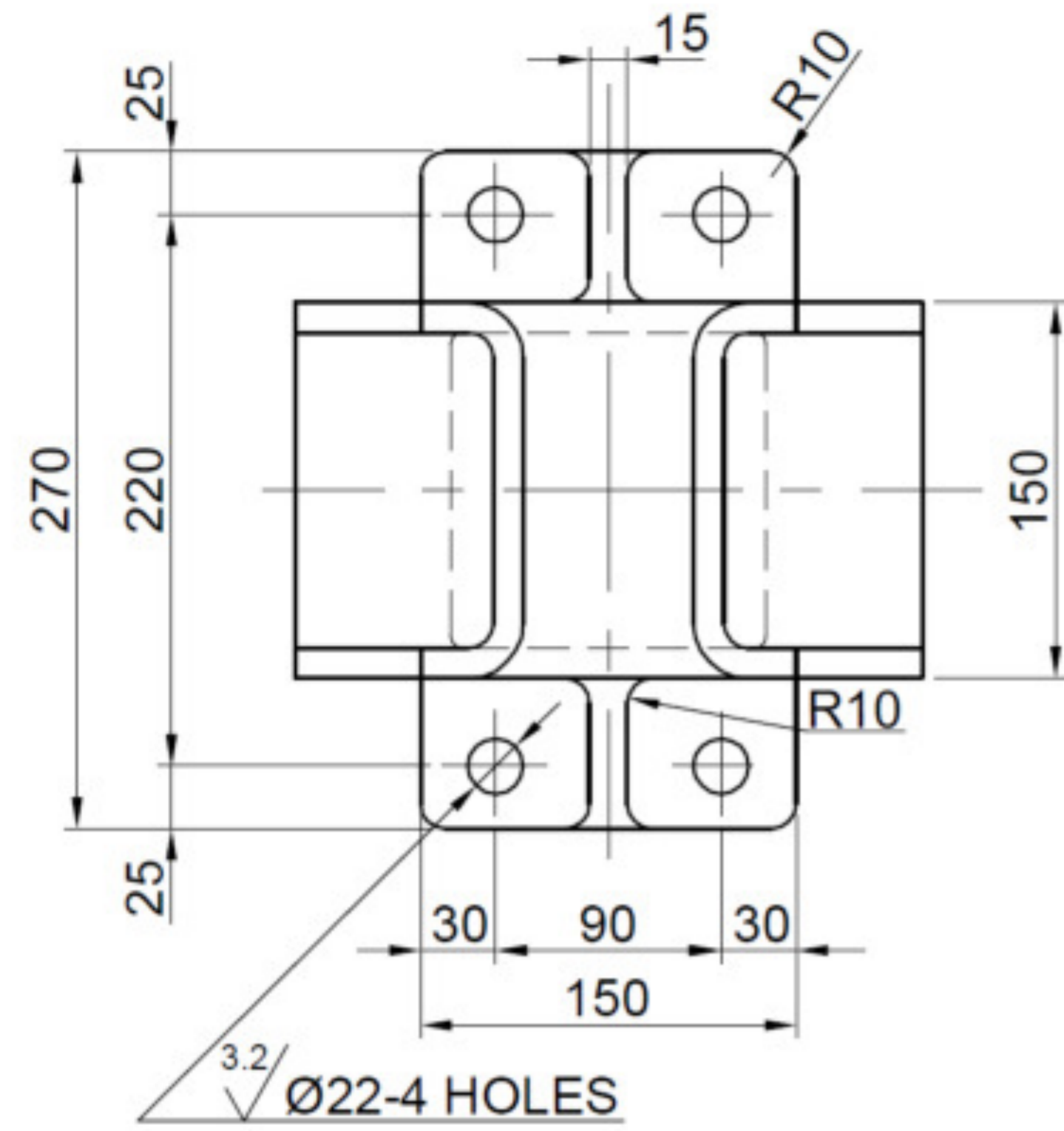

NOTES:

- 1.WEIGHT VARIATION 5%
- 2.WARPAGE NOT TO EXCEED 3mm IN LENGTH
- 3.ALL SHARP CORNERS TO ROUNDED BY R3 UNLESS OTHERWISE STATED
- 4.FOR ORIGINAL DESIGN REF DRG No.3-7-1150-05-01362

REV 02	DATE 01.02.12	ALTERED	<i>P. Mathavan</i>
		CHECKED	<i>S.S.V. Kumar</i>
		APPROVED	<i>R. Raghavver</i>

REV 01	DATE 08.12.89	ALTERED	
		CHECKED	
		APPROVED	

SECTION AA added showing Radius
 125,130 WERE 150 AND 200 RESPECTIVELY IN THE RIB.

CAUTION: THE INFORMATION ON THIS DOCUMENT IS THE PROPERTY OF BHARAT HEAVY ELECTRICALS LIMITED. IT MUST NOT BE USED DIRECTLY OR INDIRECTLY IN ANY WAY DETRIMENTAL TO THE INTEREST OF THE COMPANY.

ITEM NO		DESCRIPTION		DRAWING NO		HN Alloy(Grade-11 IS-4522)	
						ALLOY STEEL CASTING	
						MATL CODE UNIT WT	
						MATL SPEC QTY	
EQPT: WALKING BEAM FURNACE.							
Bharat Heavy Electricals Ltd SEAMLESS STEEL TUBE PLANT TIRUCHIRAPALLI - 620014				DRN	NAME	SIGNATURE	DATE
				CHD	B.ASHOKKUMAR		23.05.02
				APPD	SSN.KUMAR		
				SHANMUGASUNDARAM.S			
DEPT	GRADE OF UNTOL. DIM	SCALE	WEIGHT (Kg)	REF TO ASSY DWG NO		ITEM	
SSTP	Ø/M/F	1:5		REF TO OLD DWG NO			
456	IS: 2102			7621 / 409-3			
TITLE				CARD CODE	DRAWING NO :		REV
WBF - FIXED BEAM SUPPORT				U 01	3-7-1150-05-02845		02

