

ALL DIMENSIONS ARE IN MILLIMETRES

DRAWING NO: 3-7-1150-04-02844

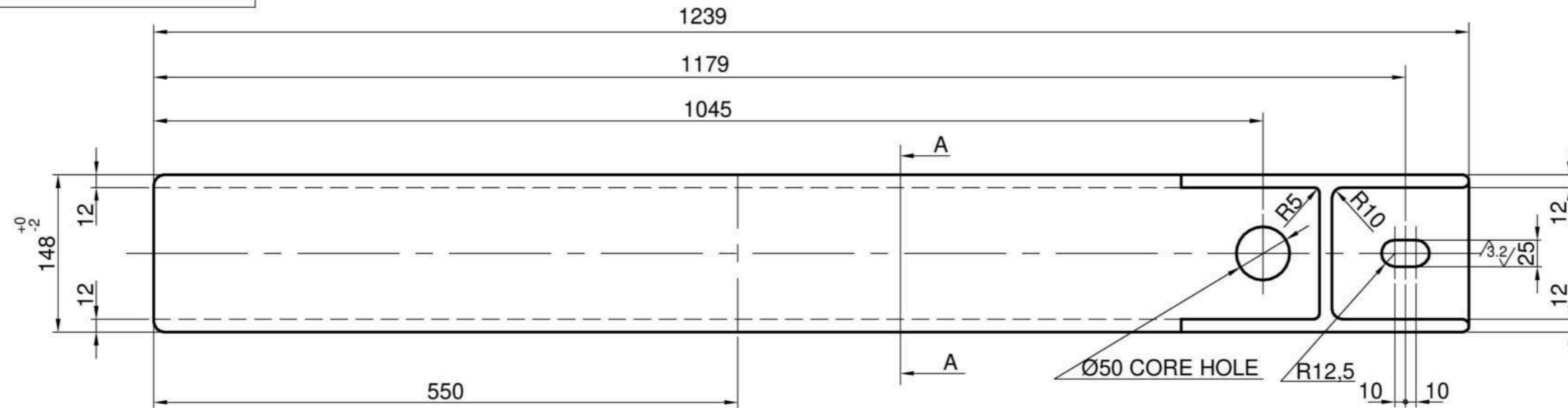

MAINTAIN TOLERANCE-2mm ON 148SQ FOR LENGTH OF 550 mm.

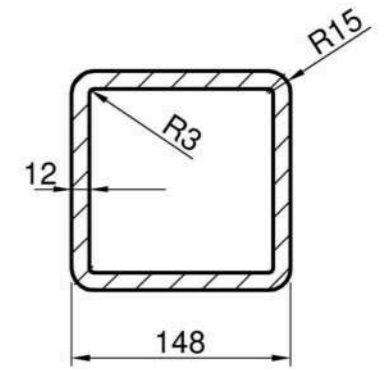

Section A-A

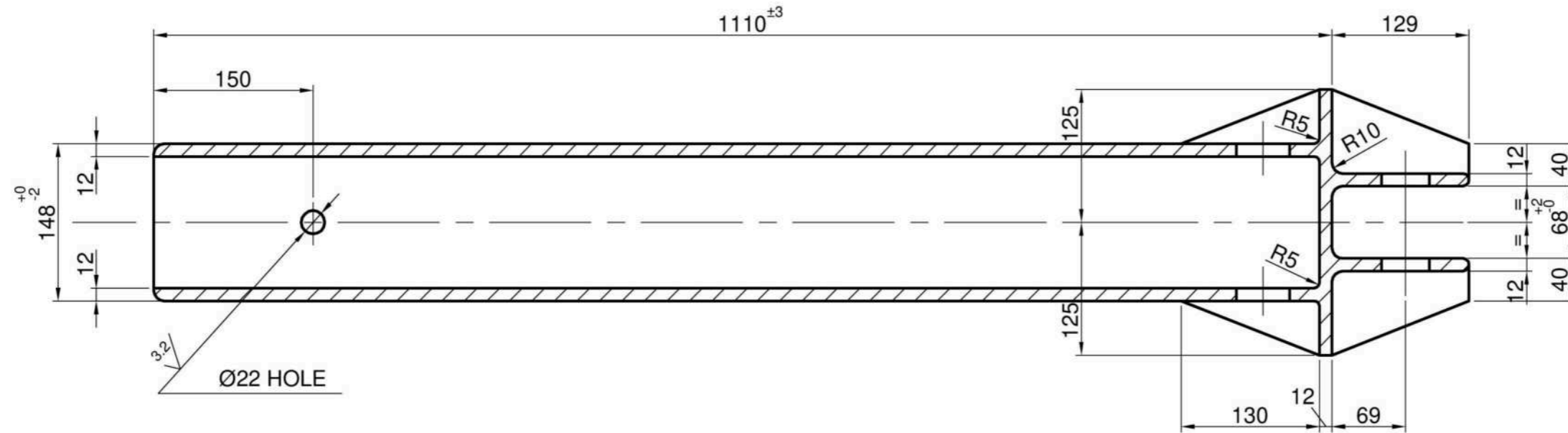

NOTES:

- WEIGHT VARIATION ± 5 %
- WARPAGE NOT TO EXCEED 4mm LENGTH.
- ALL SHARP CORNERS TO BE ROUNDED BY R3.UNLESS OTHERWISE STATED FOR ORIGINAL DESIGN REF DRG No.3-7-1150-04-01361

REV 02	DATE 01.02.12	ALTERED P. Mathavan
		CHECKED SSN Kumar
		APPROVED R. Raghavver

REV 01	DATE 08.12.89	ALTERED
		CHECKED
		APPROVED

Section A introduced showing Radius

125,130 WERE 150 AND 200 RESPECTIVELY,IN THE RIB.

CAUTION: THE INFORMATION ON THIS DOCUMENT IS THE PROPERTY OF BHARAT HEAVY ELECTRICALS LIMITED.IT MUST NOT BE USED DIRECTLY OR INDIRECTLY IN ANY WAY DETRIMENTAL TO THE INTEREST OF THE COMPANY.

ITEM NO		DESCRIPTION		DRAWING NO		AS PER INDENT AND TDC		
						ALLOY STEEL CASTING		
						MATL CODE UNIT WT		
						MATL SPEC QTY		
EQPT: WALKING BEAM FURNACE								
Bharat Heavy Electricals Ltd SEAMLESS STEEL TUBE PLANT TIRUCHIRAPALLI - 620014				DRN	NAME B.ASHOKKUMAR		SIGNATURE	DATE 24.05.02
				CHD	SSN.KUMAR			
				APPD	SHANMUGASUNDARAM.S			
DEPT S5TP	GRADE OF UNTOL. DIM	SCALE	WEIGHT (Kg)	REF TO ASSY DWG NO		ITEM		
CODE 456	φ/M/F IS: 2102	1:5	73.67	REF TO OLD DWG NO 7621 / 408-3				
TITLE				CARD CODE	DRAWING NO :		REV	
WBF - MOVABLE BEAM SUPPORT				U 01	3-7-1150-04-02844		02	

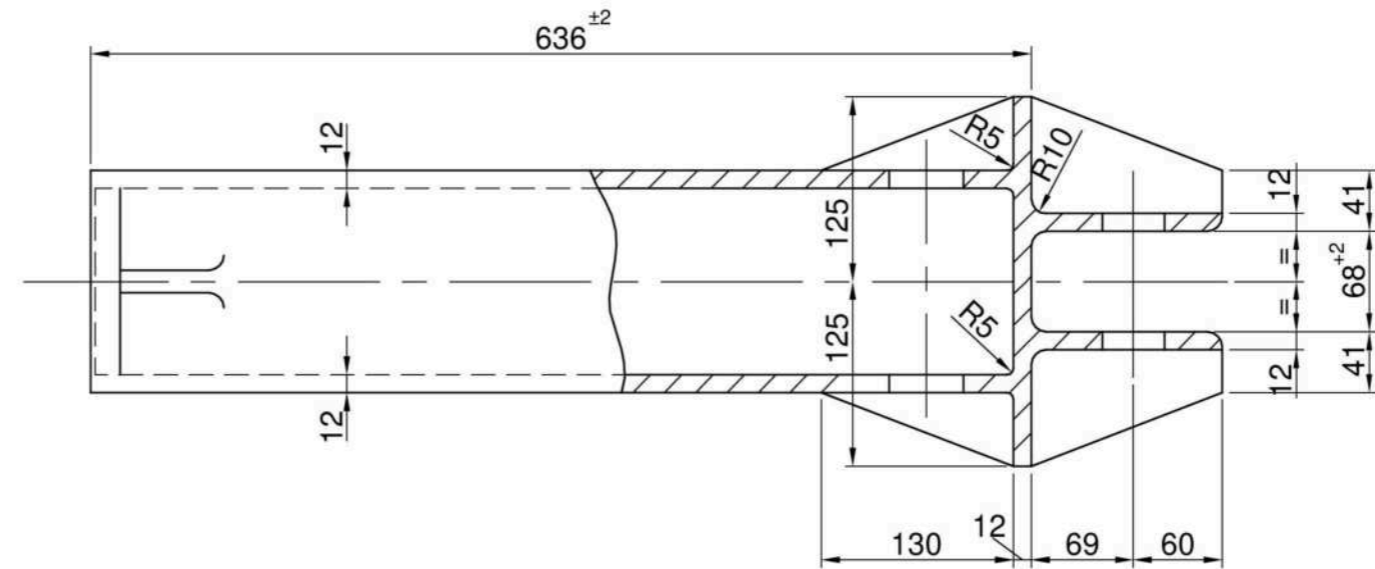
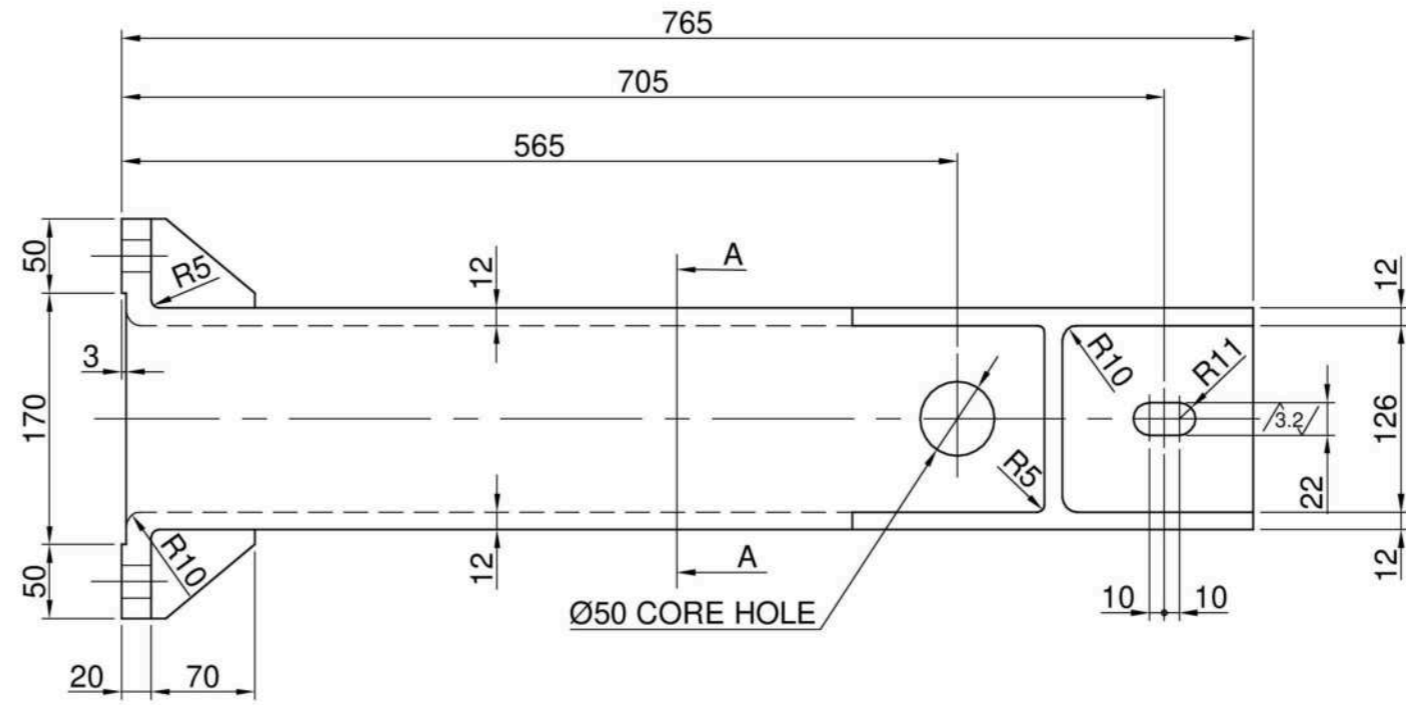
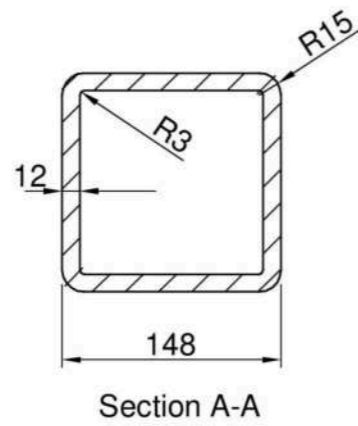
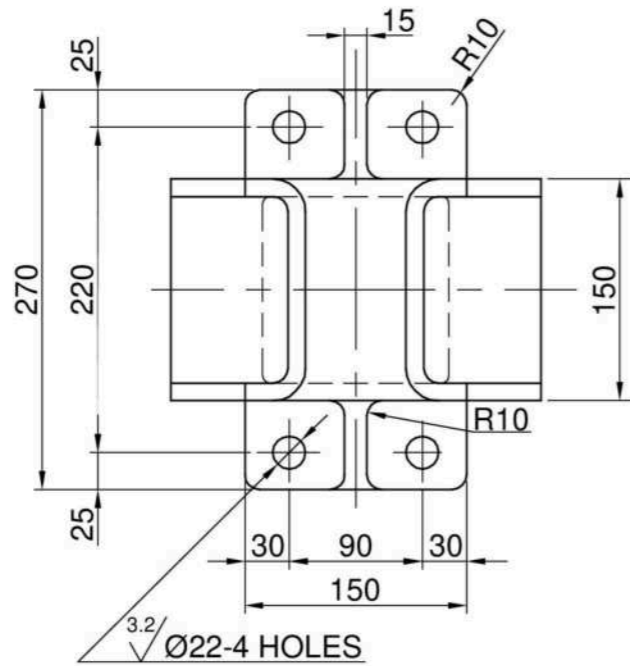

NOTES:

- 1.WEIGHT VARIATION 5%
- 2.WARPAGE NOT TO EXCEED 3mm IN LENGTH
- 3.ALL SHARP CORNERS TO ROUNDED BY R3 UNLESS OTHERWISE STATED
- 4.FOR ORIGINAL DESIGN REF DRG No.3-7-1150-05-01362

REV 02	DATE 01.02.12	ALTERED P. Mathavan
		CHECKED SSN Kumar
		APPROVED R. Raghavveer

REV 01	DATE 08.12.89	ALTERED
		CHECKED
		APPROVED

SECTION AA added showing Radius

125,130 WERE 150 AND 200 RESPECTIVELY IN THE RIB.

CAUTION: THE INFORMATION ON THIS DOCUMENT IS THE PROPERTY OF BHARAT HEAVY ELECTRICALS LIMITED. IT MUST NOT BE USED DIRECTLY OR INDIRECTLY IN ANY WAY DETRIMENTAL TO THE INTEREST OF THE COMPANY.

		AS PER INDENT AND TDC	
		ALLOY STEEL CASTING	
ITEM NO	DESCRIPTION	DRAWING NO	MATL CODE
			UNIT WT
			MATL SPEC
			QTY
EQPT: WALKING BEAM FURNACE.			
Bharat Heavy Electricals Ltd SEAMLESS STEEL TUBE PLANT TIRUCHIRAPALLI - 620014		DRN	NAME B.ASHOKKUMAR
		CHD	SSN.KUMAR
		APPD	SHANMUGASUNDARAM.S
DEPT S5TP	GRADE OF UNTOL. DIM	SCALE	WEIGHT (Kg)
CODE 456	φ/M/F IS: 2102	1:5	51.67
TITLE		CARD CODE	REF TO ASSY DWG NO
WBF - FIXED BEAM SUPPORT		U 01	REF TO OLD DWG NO 7621 / 409-3
		DRAWING NO :	REV
		3-7-1150-05-02845	02

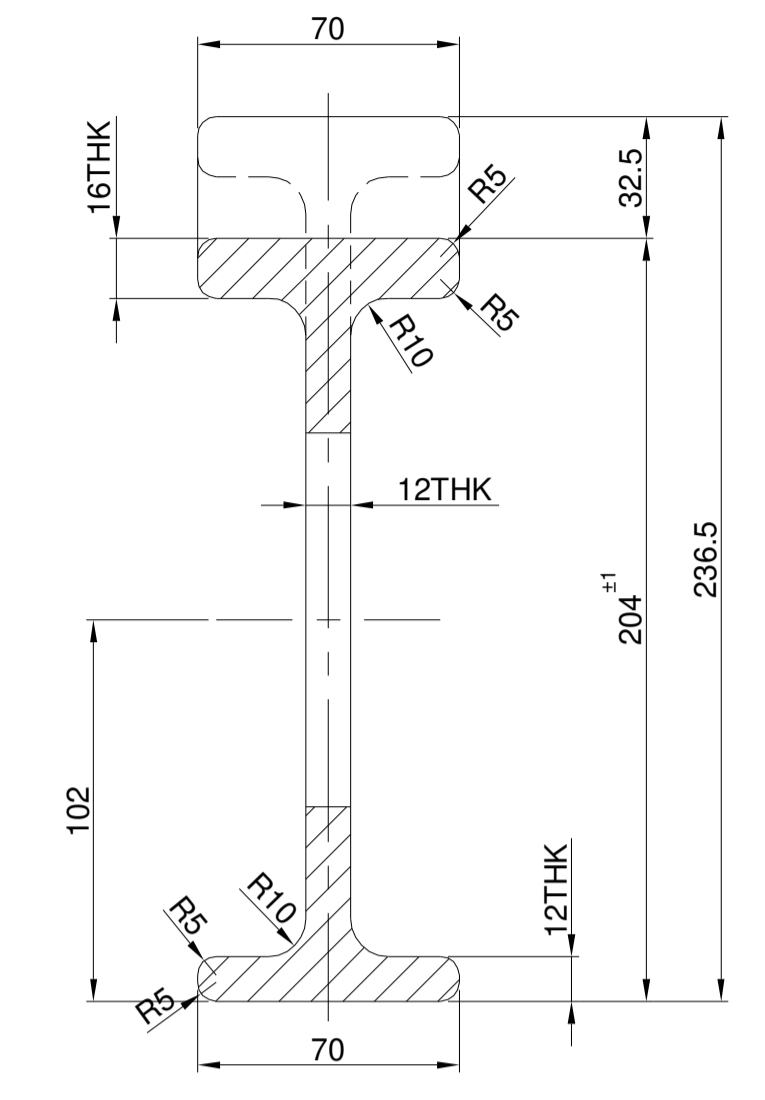
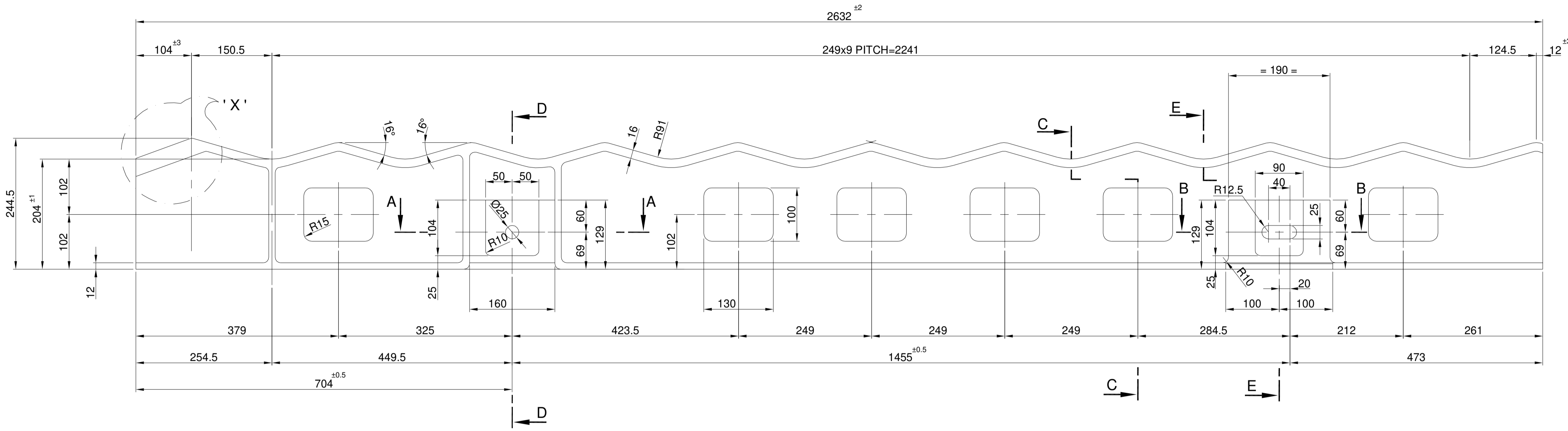

SECTION-CC

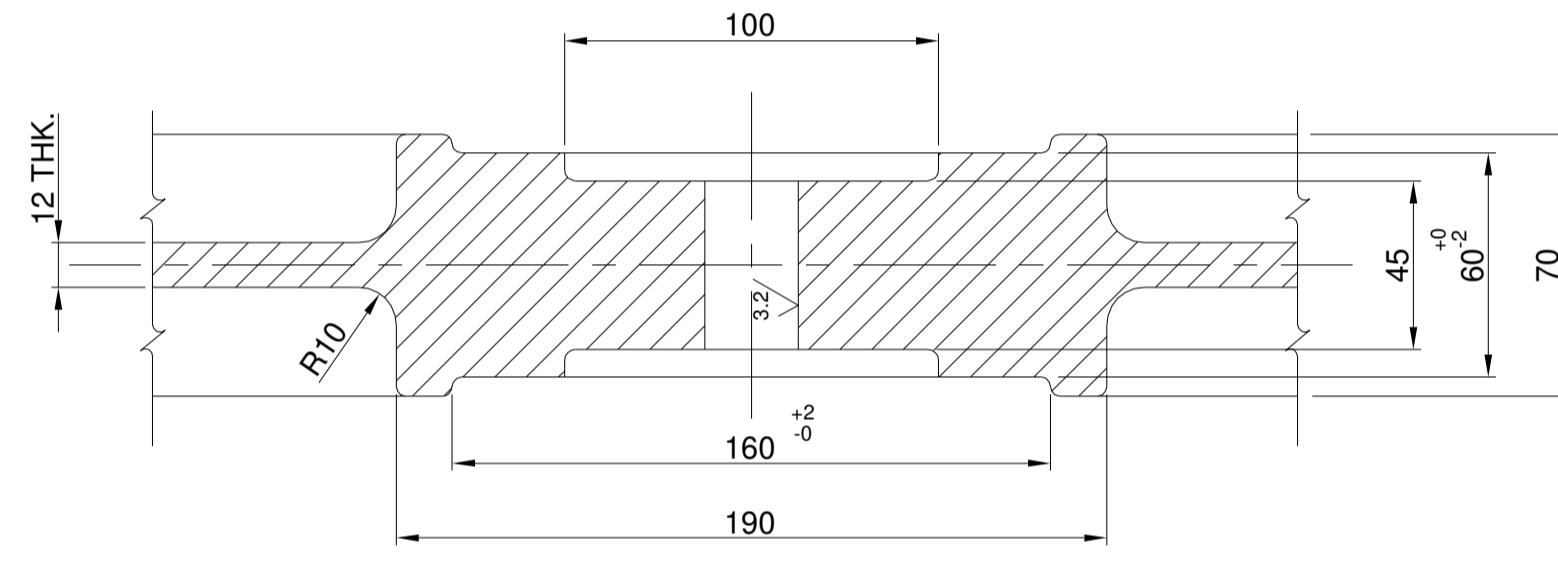

SECTION-AA

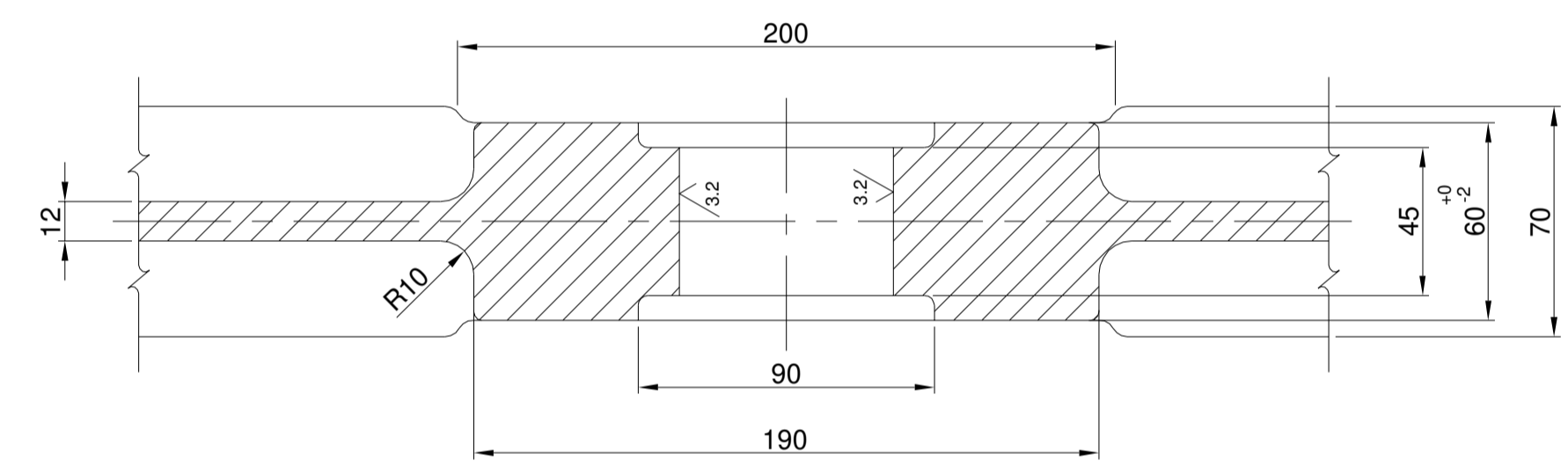

SECTION-BB

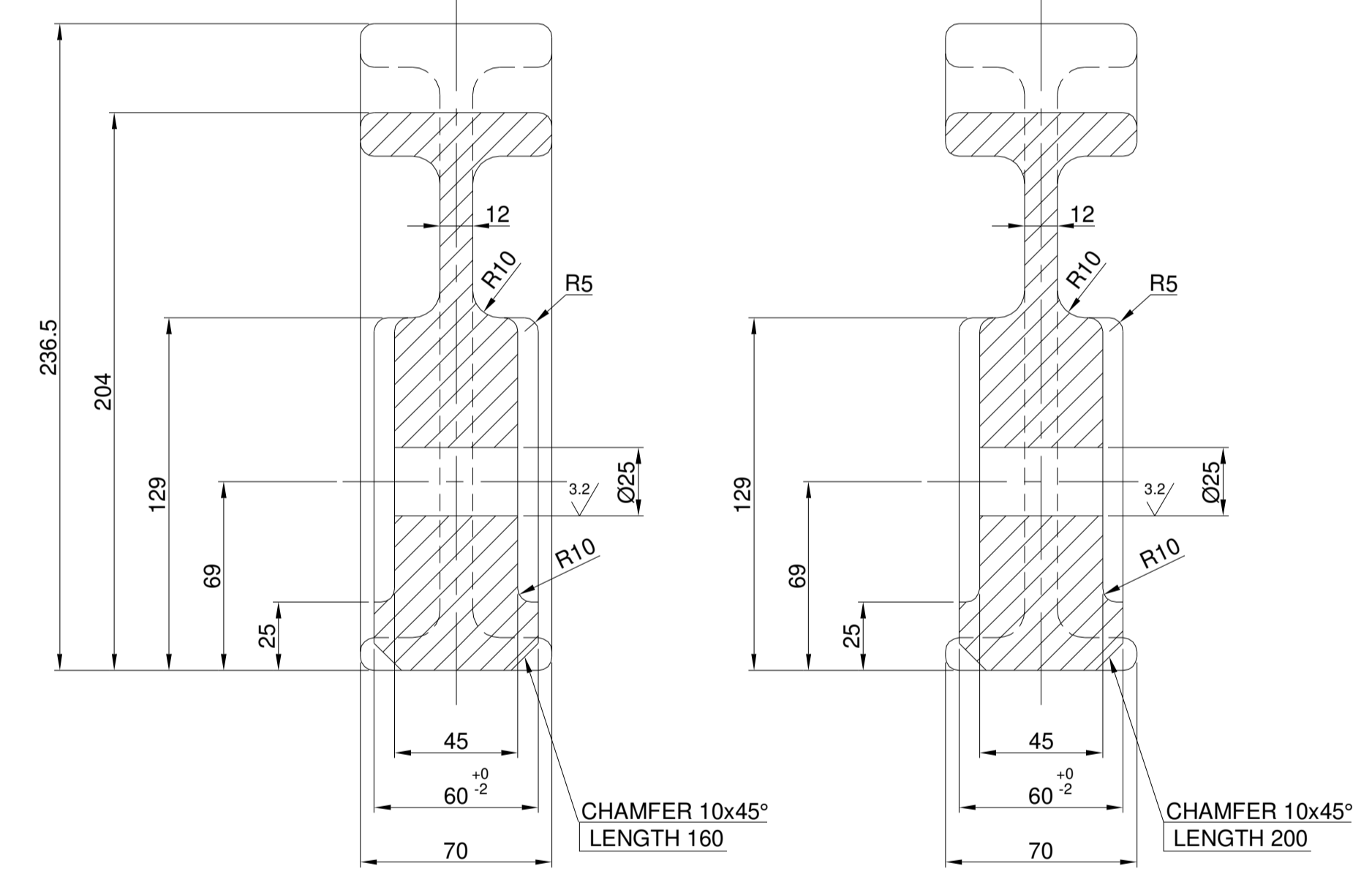

SECTION-DD

SECTION-EE

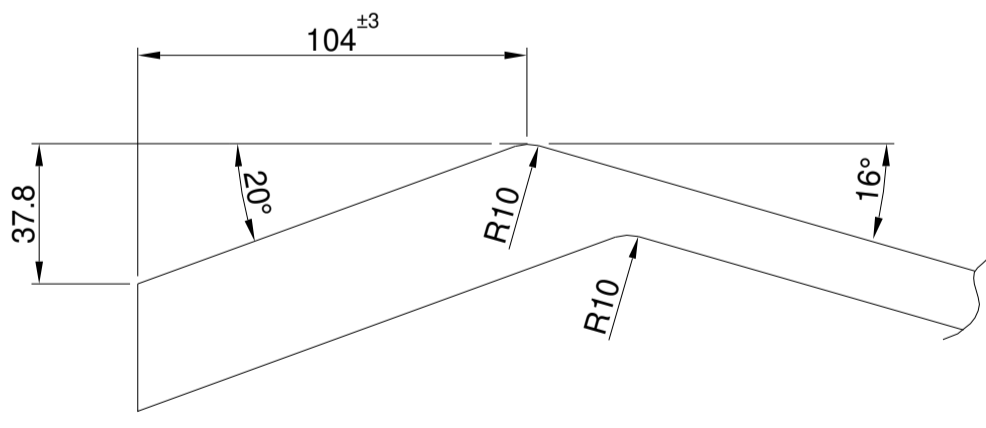

DETAIL-X

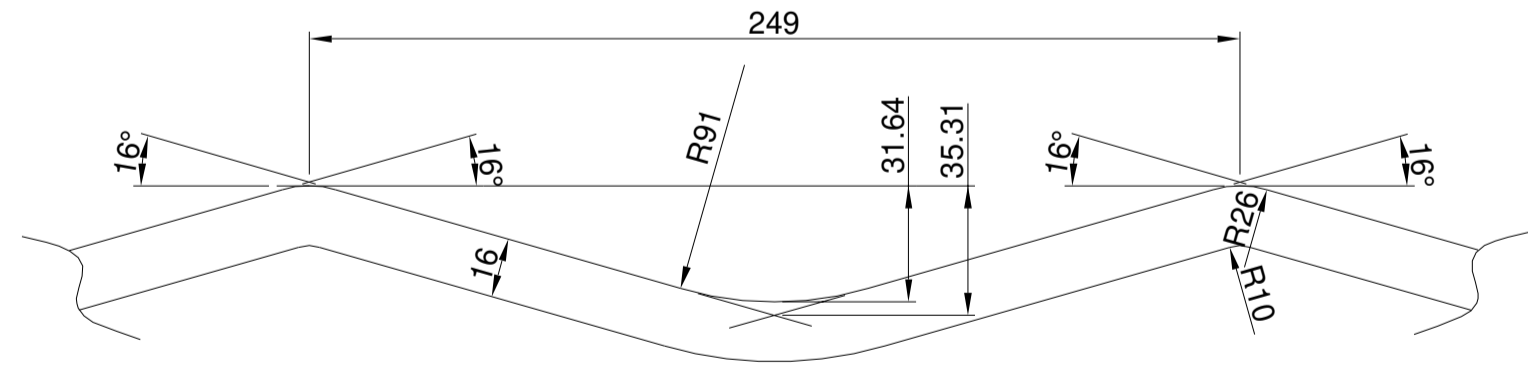

DETAIL-Y

- NOTES:**
1. ALL SHARP CORNERS ARE TO BE ROUNDED R3. WHERE NOT SPECIFIED.
 2. WEIGHT VARIATION ±5%
 3. WARPAGE NOT TO EXCEED 3 TO 5 IN ANY DIRECTION
 4. UNIT WT: 104Kg, REQD. QTY: 8 Nos. MATL: AS PER INDENT AND TDC

REV	DATE	ALTERED :	REV	DATE	ALTERED :	REV	DATE	ALTERED :	REV	DATE	ALTERED :
04		CHECKED :	03	16.12.89	CHECKED :	02	09.01.89	CHECKED :	01	08.05.85	CHECKED :
		APPROVED:			APPROVED:			APPROVED:			APPROVED:

ENTRI SIDE ALTERED TO HAVE FREE TRANSFER OF HOLLOWES DURING REVERSE CYCLE.

DIMENSIONS 9 ALTERED.

DIMENSIONS ALTERED 17 AND TOLARANCE ADDED.

ITEM NO	DESCRIPTION	DRAWING NO	MATL CODE	UNIT WT
EQUIPMENT: WALKING BEAM FURNACE				
Bharat Heavy Electricals Ltd SEAMLESS STEEL TUBE PLANT TIRUCHIRAPALLI - 620014			DRN	NAME
			CHD	BASHOKKUMAR
			APPD	SSN KUMAR
				S.SHANMUGASUNDARAM
DEPT	MPG	SCALE	WEIGHT (Kg)	ITEM NO
		1:5 (1:2)	105.7	
TITLE	CARD CODE	DRAWING NO :	REF TO ASSY DWG NO	REF TO OLD DWG NO
WALKING BEAM CASTING DISCHARGING END	U 01	1-7-1150-05-02073	7821 / 403-1c	

~ / 3.2 /

CAUTION: THE INFORMATION ON THIS DOCUMENT IS THE PROPERTY OF BHARAT HEAVY ELECTRICALS LTD. IT MUST NOT BE USED DIRECTLY OR INDIRECTLY IN ANY MANNER TO INTEREST OF THE COMPANY.

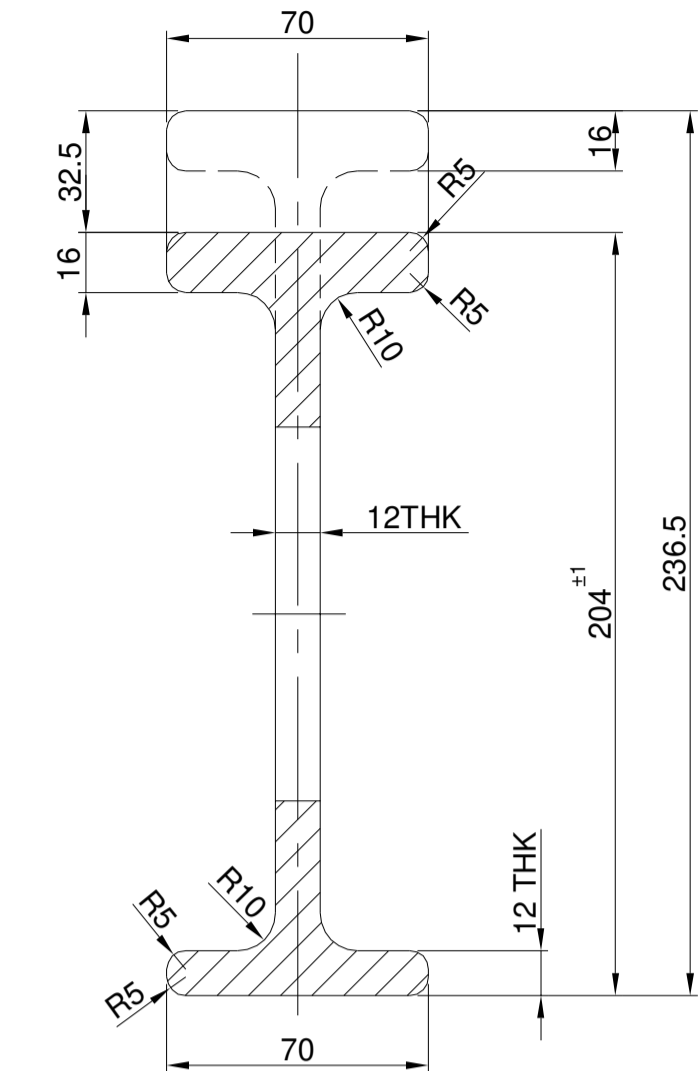
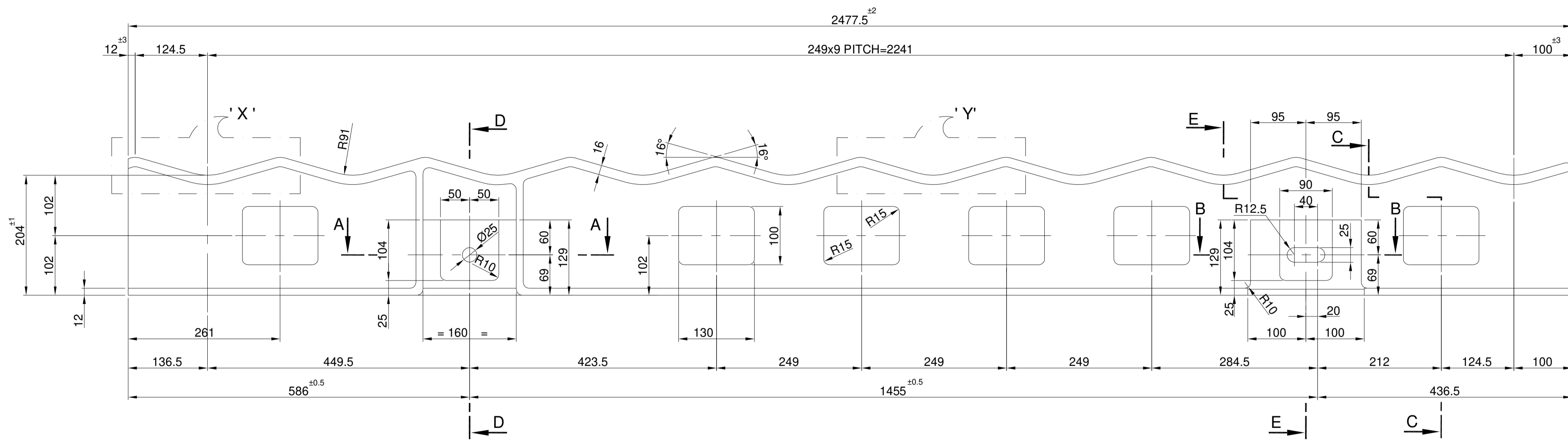

SECTION-CC

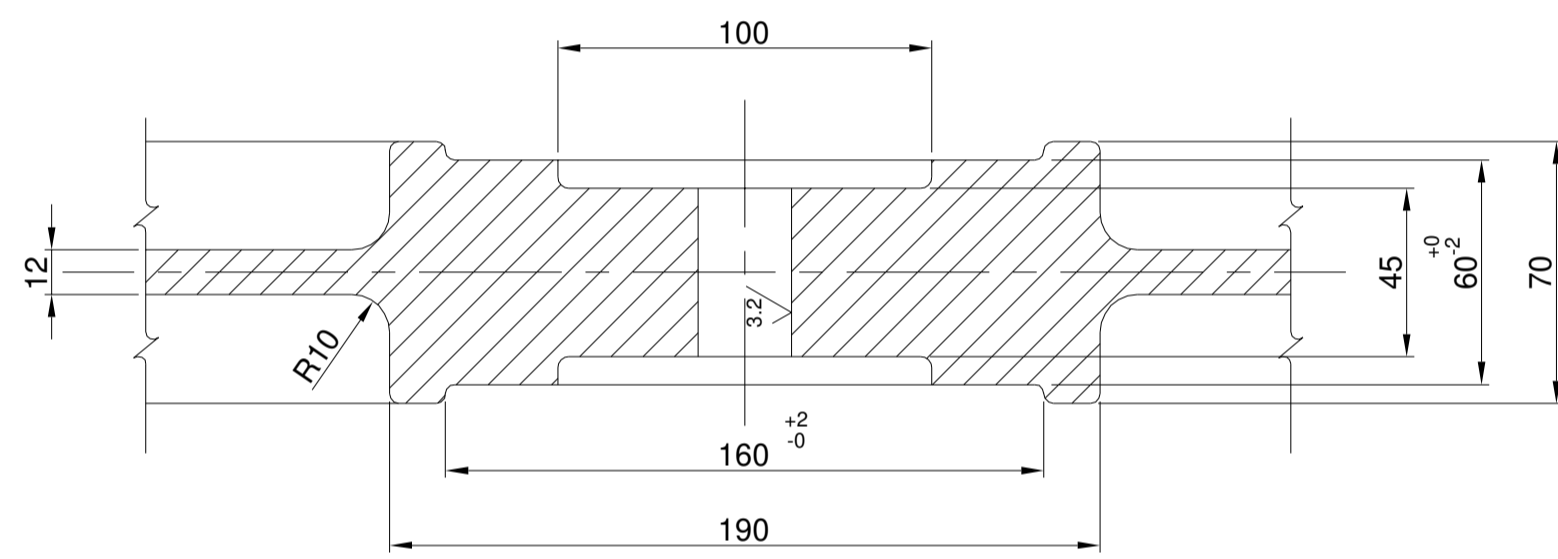

SECTION-AA

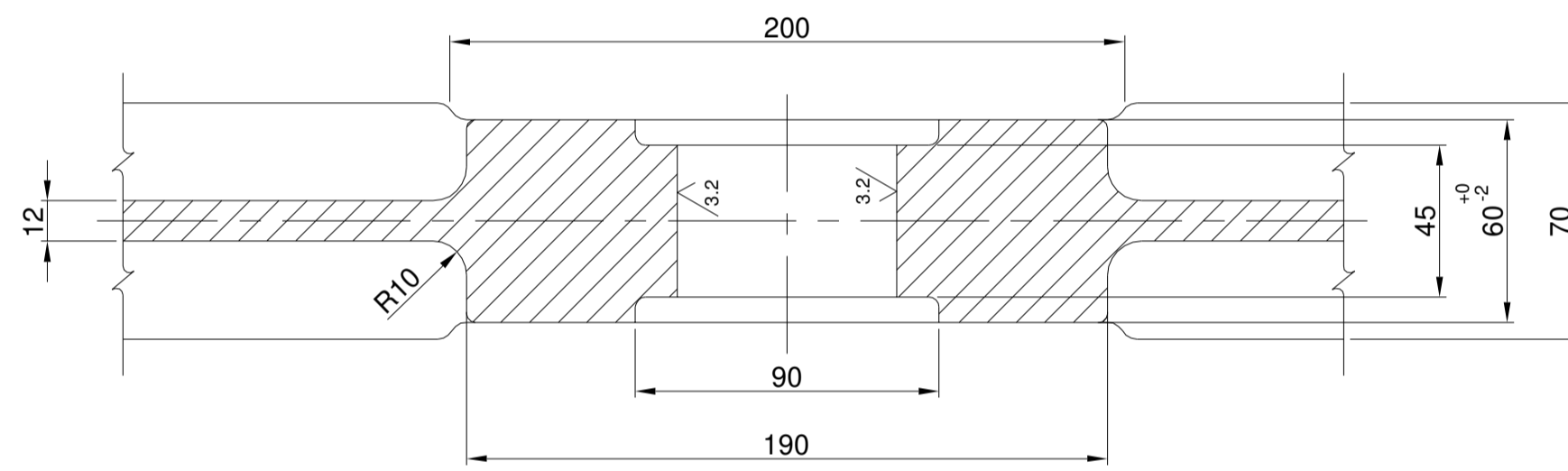

SECTION-BB

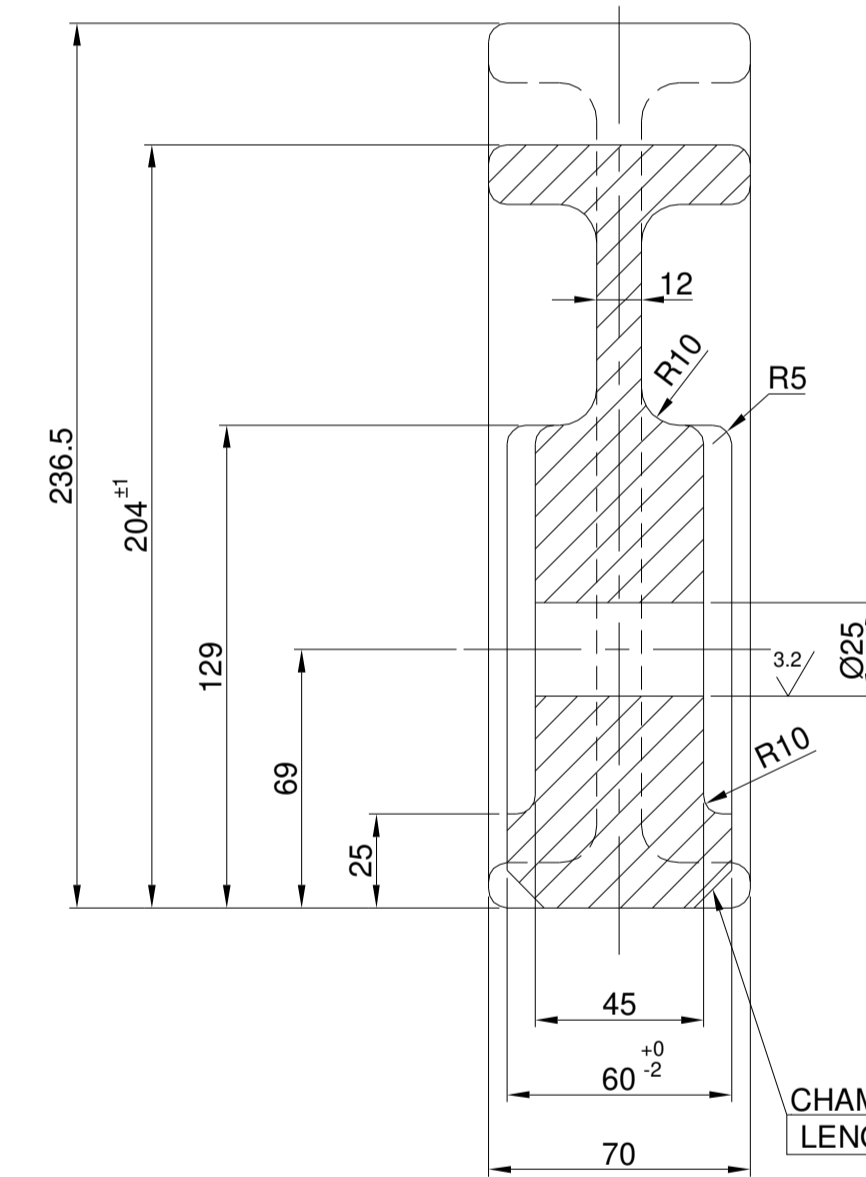

SECTION-DD

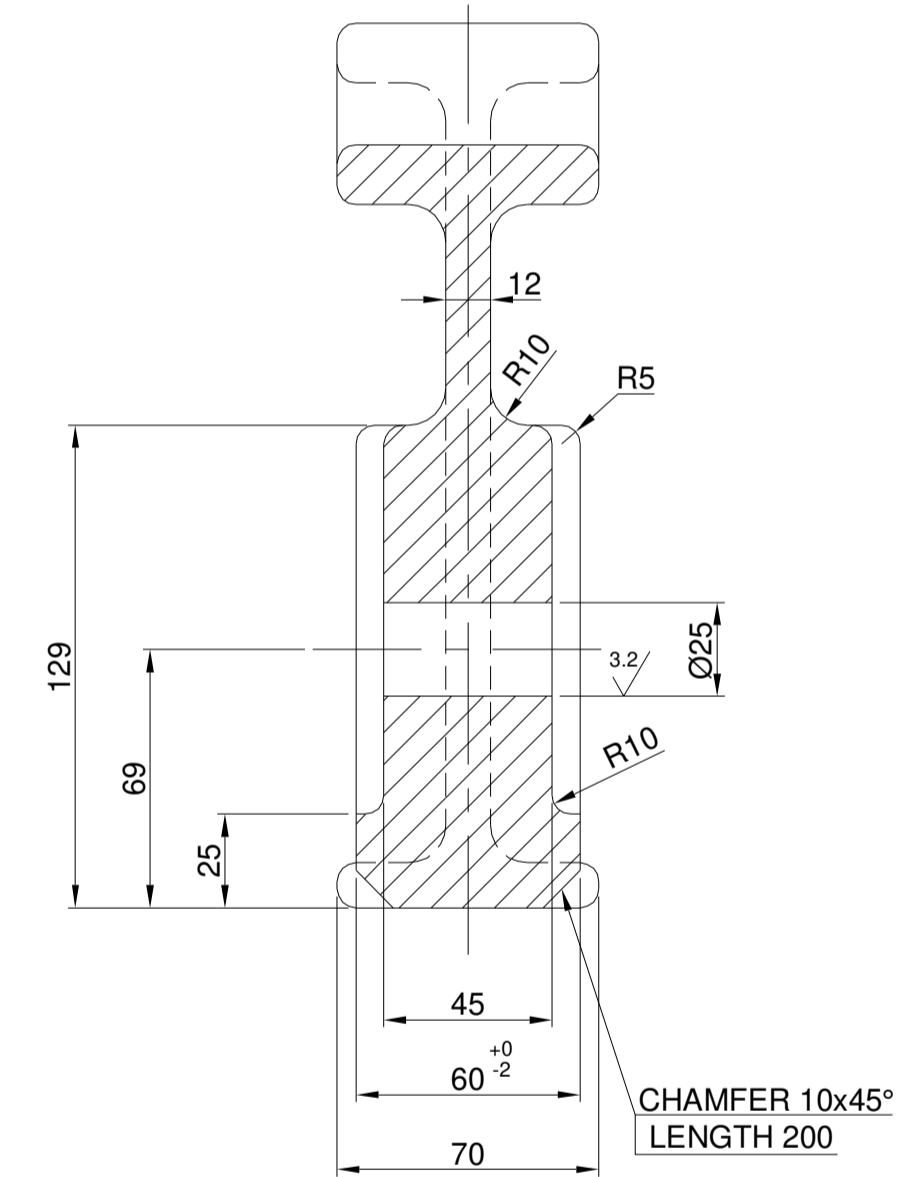

SECTION-EE

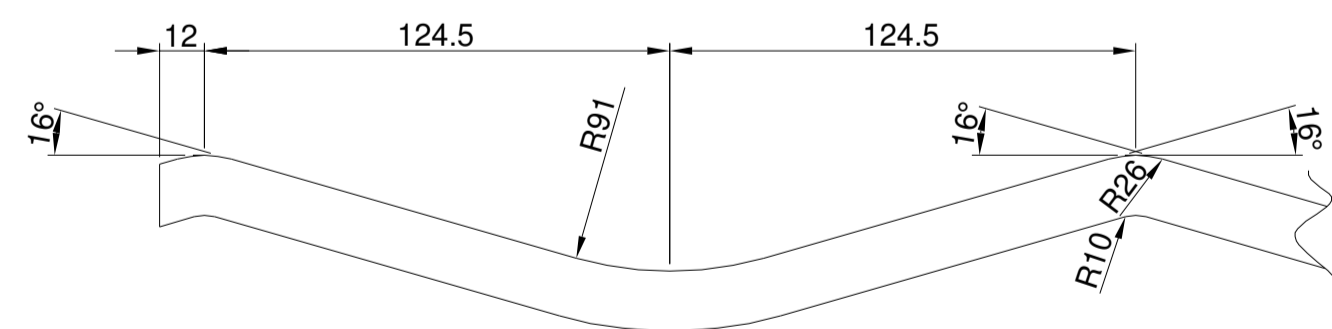

DETAIL-X

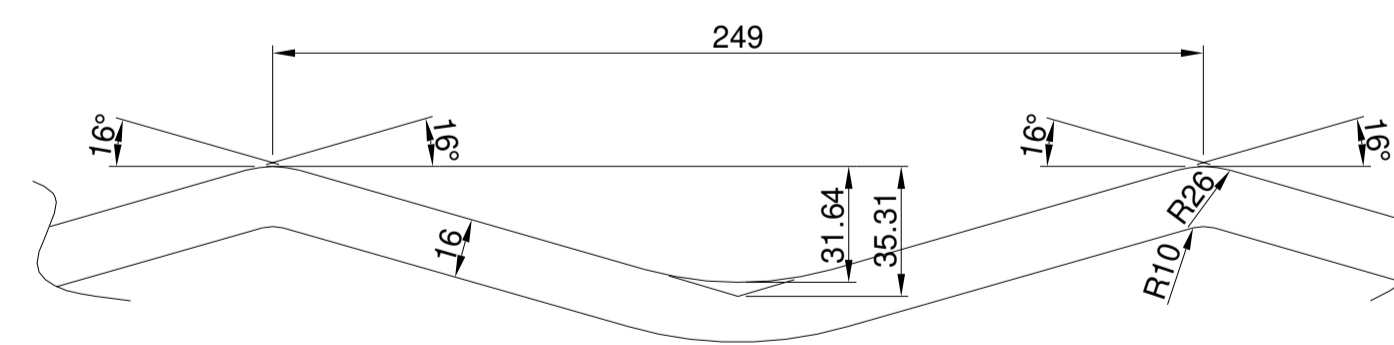

DETAIL-Y

NOTES:

1. ALL SHARP CORNERS ARE TO BE ROUNDED R3. WHERE NOT SPECIFIED.
2. WEIGHT VARIATION ±5%.
3. WARPAGE NOT TO EXCEED 3 TO 5 IN ANY DIRECTION.
4. REQD QTY :8Nos.

REV 06	DATE	ALTERED :	REV 05	DATE	ALTERED :	REV 04	DATE	ALTERED :	REV 03	DATE	ALTERED :	REV 02	DATE	ALTERED :	REV 01	DATE	ALTERED :
ZONE		CHECKED :	ZONE		CHECKED :	ZONE		CHECKED :	ZONE		CHECKED :	ZONE		CHECKED :	ZONE		CHECKED :
		APPROVED:			APPROVED:			APPROVED:			APPROVED:			APPROVED:			APPROVED:

DIMENSIONS ALTERED.

DIMENSIONS ALTERED 16 AND TOL. ADDED.

AS PER INDENT AND TDC		MATERIAL CODE		UNIT WT	
ITEM NO	DESCRIPTION	DRAWING NO	MATERIAL SPEC	QTY	
EQUIPMENT: WALKING BEAM FURNACE					
Bharat Heavy Electricals Ltd SEAMLESS STEEL TUBE PLANT TIRUCHIRAPALLI - 620014			DRN	NAME	SIGNATURE
			CHD	SSN KUMAR	DATE
			APPD	S SHANMUGASUNDARAM	03.06.02
DEPT	MPG	GRADE OF UNIT	SCALE	WEIGHT (Kg)	REF TO ASSY DWG NO
		U 01	1:5 (1:2)	99	7621 / 401-1
DRAWING NO :			CARD CODE	REV	
1-7-1150-04-02074			U 01	02	

MOVABLE HEARTH CASTING CHARGING END

~ 3.2/

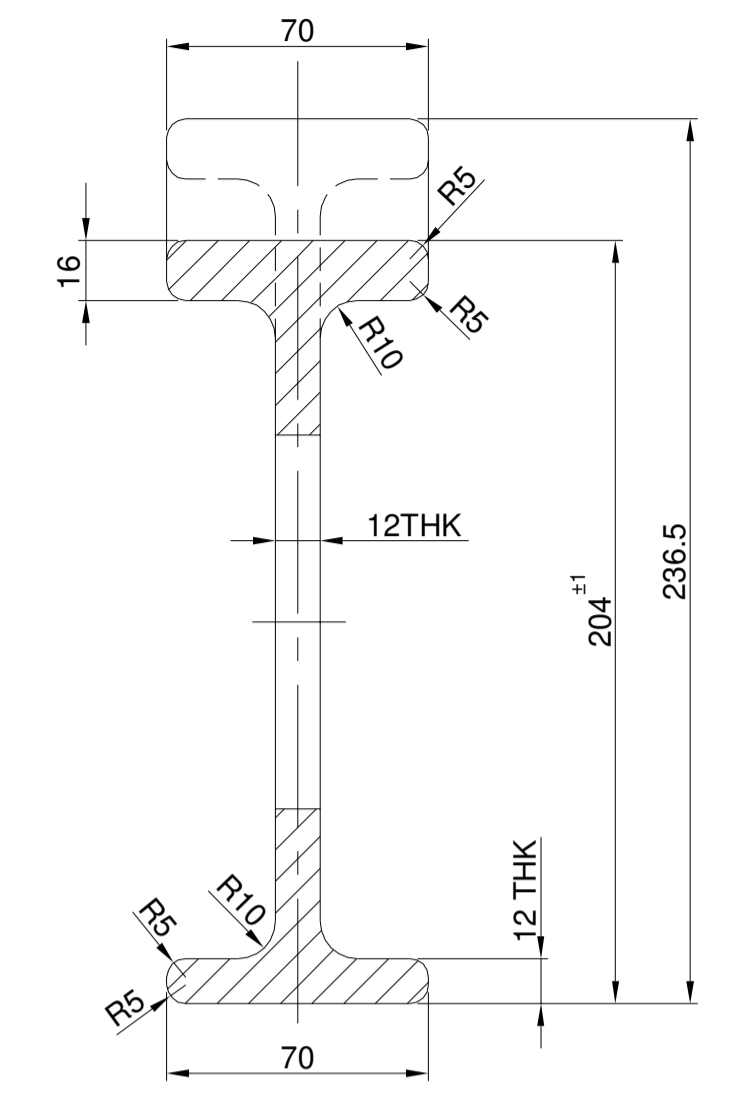
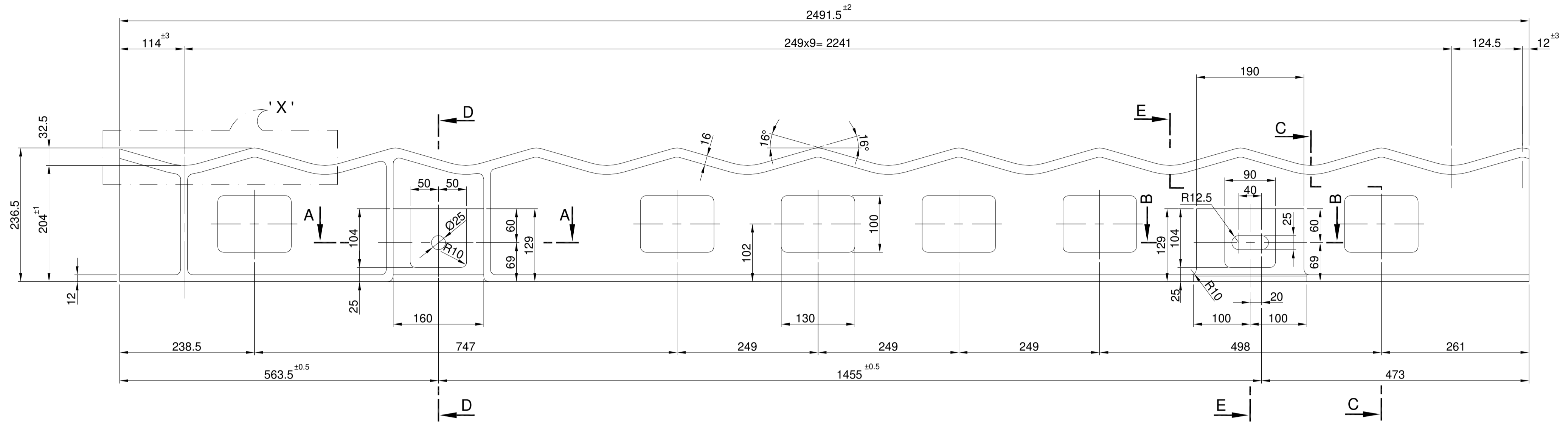

SECTION-CC

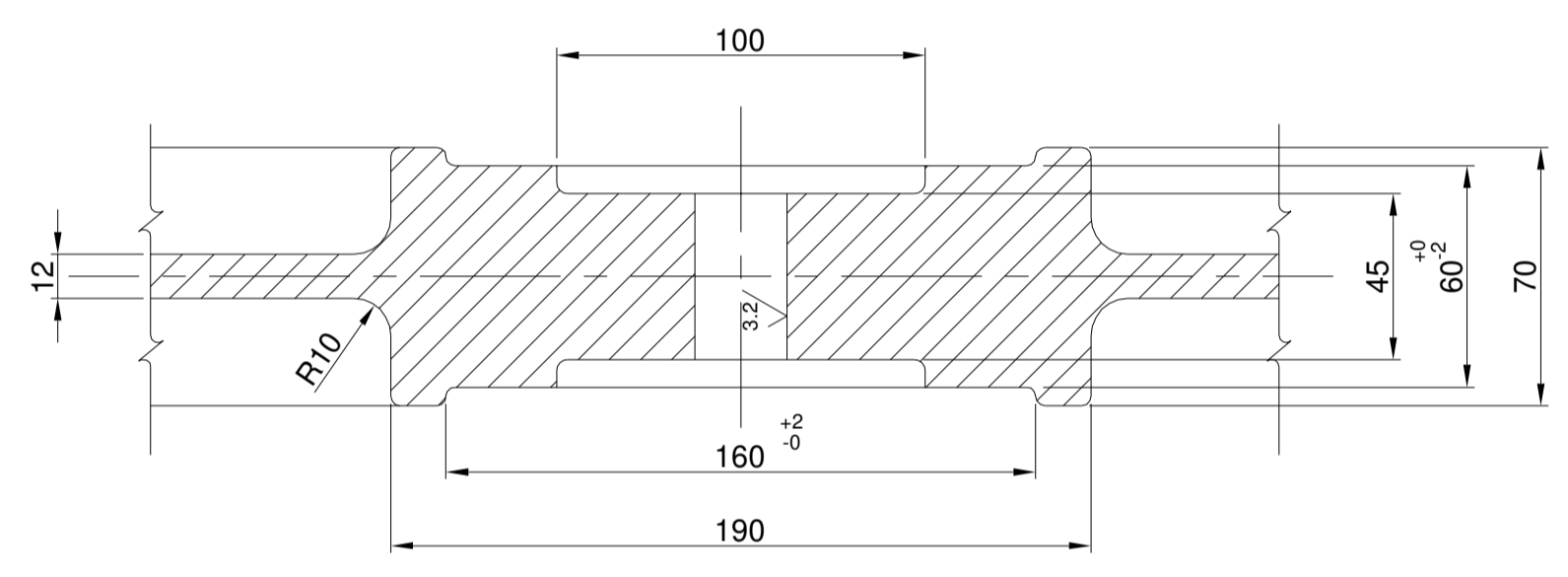

SECTION-AA

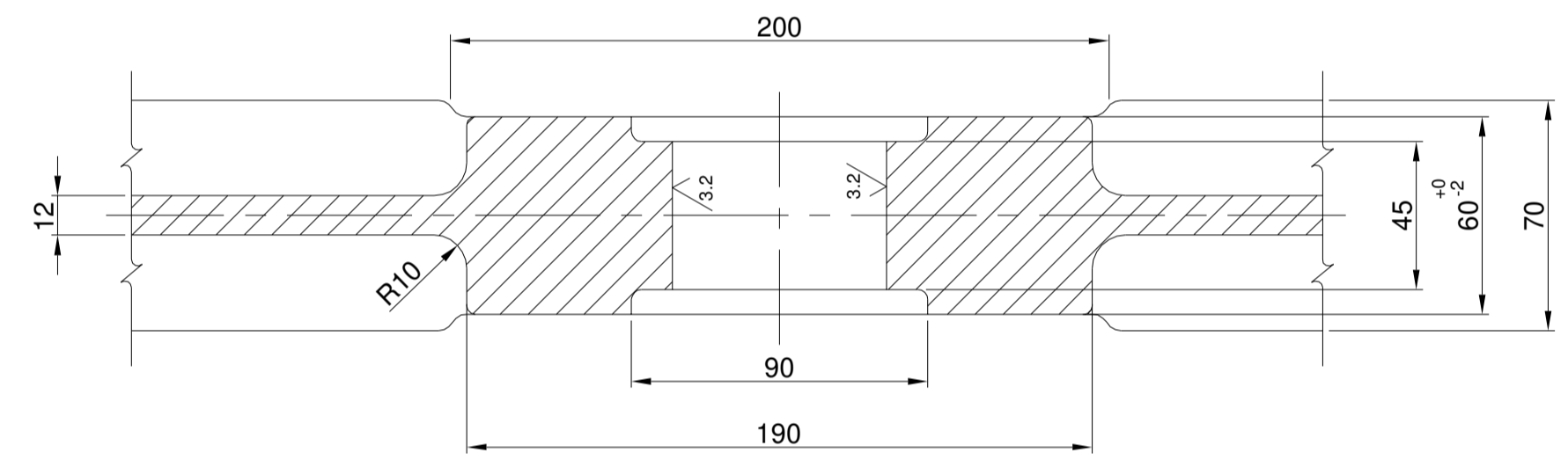

SECTION-BB

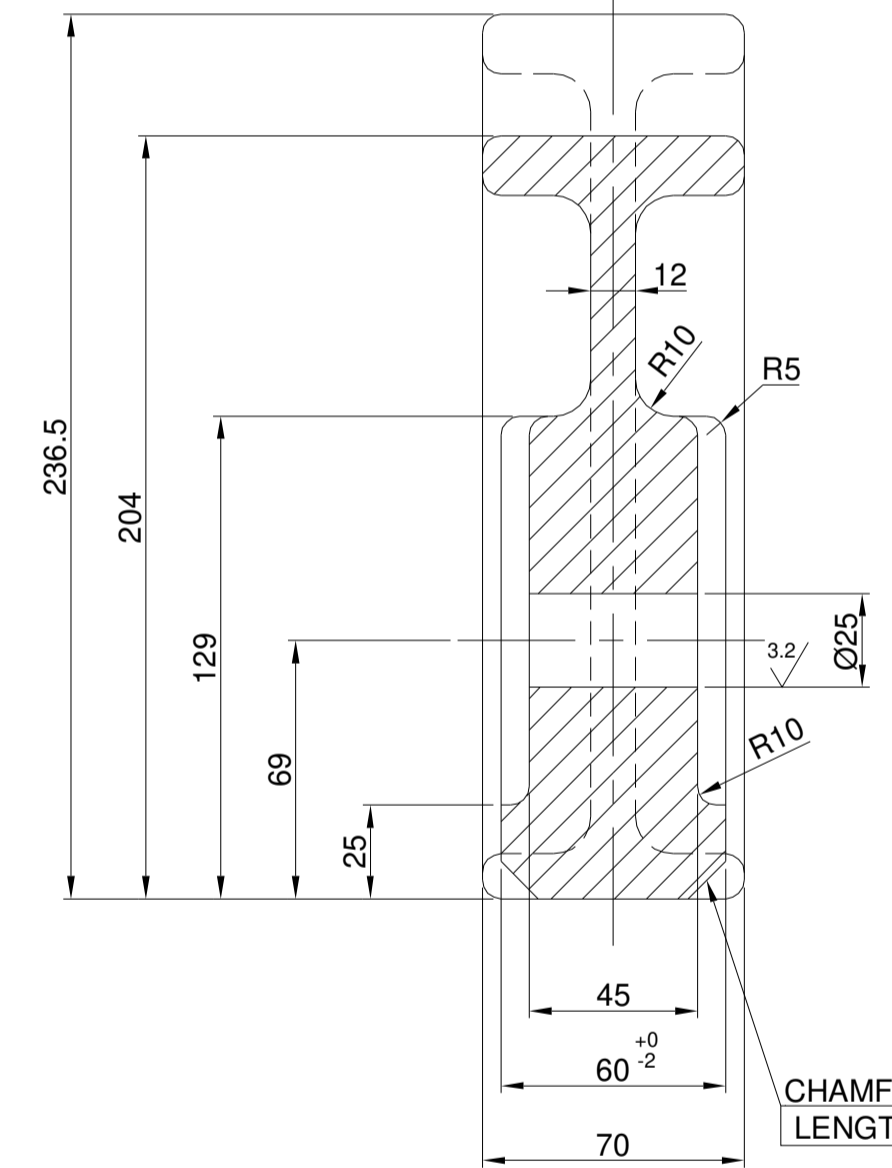

SECTION-DD

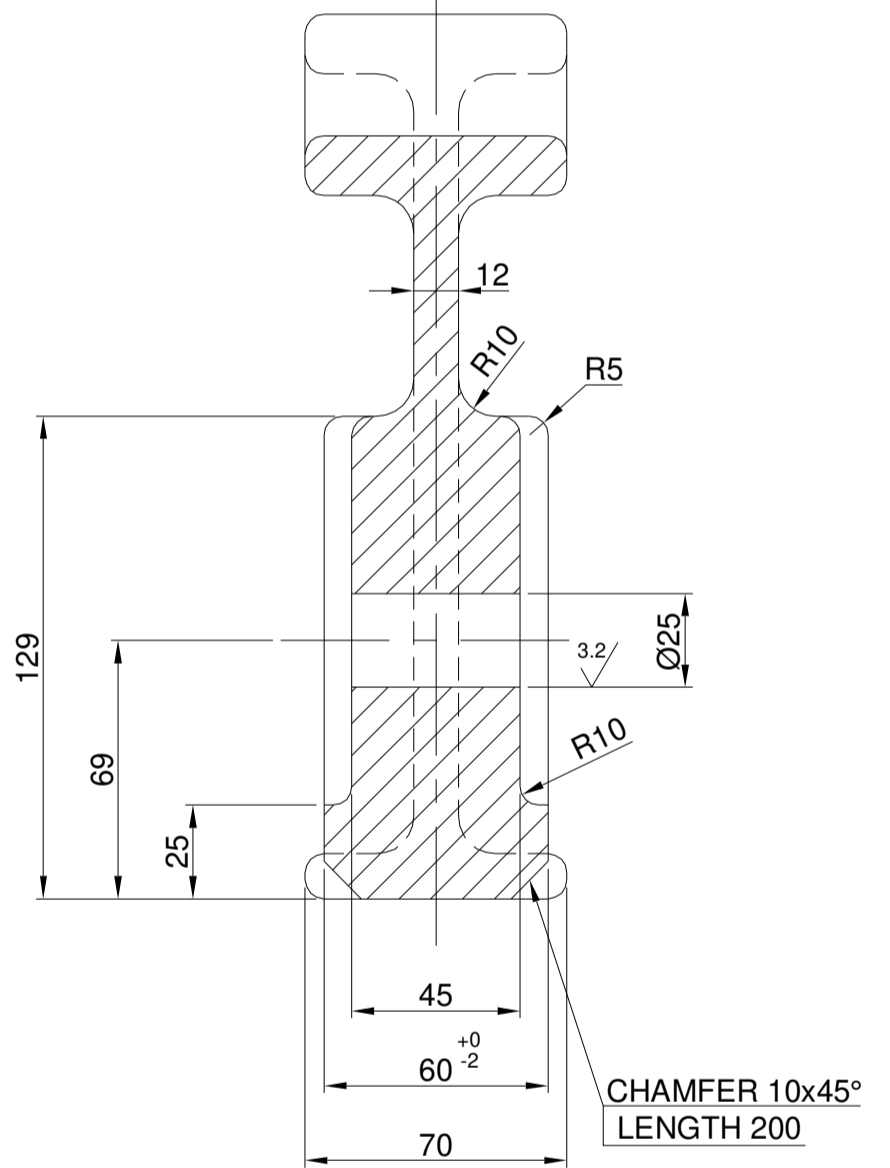

SECTION-EE

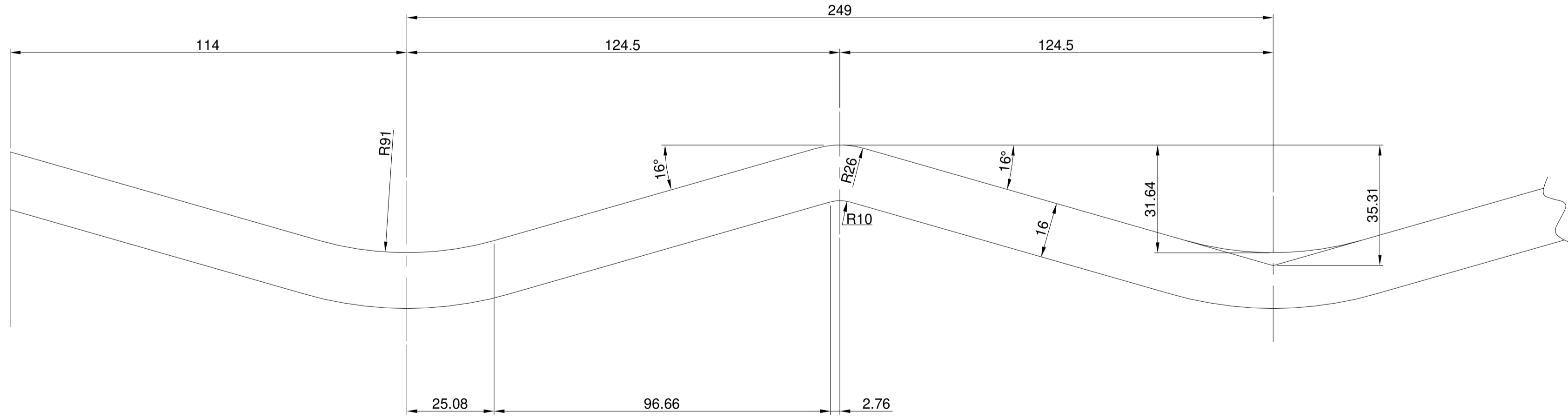

DETAIL-X

NOTES:
 ALL SHARP CORNERS ARE TO BE ROUNDED R3, WHERE NOT SPECIFIED.
 WARPAGE NOT TO EXCEED 3 TO 5 IN ANY DIRECTION.
 WEIGHT VARIATION ±5%.

REV 06	DATE	ALTERED : CHECKED :	REV 05	DATE	ALTERED : CHECKED :	REV 04	DATE	ALTERED : CHECKED :	REV 03	DATE	ALTERED : CHECKED :	REV 02	DATE	ALTERED : CHECKED :	REV 01	DATE	ALTERED : CHECKED :
ZONE		APPROVED:	ZONE		APPROVED:	ZONE		APPROVED:	ZONE		APPROVED:	ZONE		APPROVED:	ZONE		APPROVED:

DIMENSIONS ALTERED AND TOL.ADDED.

AS PER INDENT AND TDC		ITEM NO		DESCRIPTION		DRAWING NO		MATERIAL CODE		UNIT WT	
EQUIPMENT: WALKING BEAM FURNACE		NAME: BASHOKKUMAR		SIGNATURE		DATE: 30.05.02		MATERIAL SPEC		QTY	
Bharat Heavy Electricals Ltd		DRN: SSN KUMAR		CHD: S SHANMUGASUNDARAM		APRD: S SHANMUGASUNDARAM		SCALE: 1:5 (1:2) (1:1)		WEIGHT (Kg): 100	
SEAMLESS STEEL TUBE PLANT		TIRUCHIRAPALLI - 620014		REF TO ASSY DWG NO: 7621/401-1		REF TO OLD DWG NO:		DEPT: MPG		GRADE OF UNIT: S.M.F	
TITLE: HEARTH CASTING CHARGING END		CARD CODE: U 01		DRAWING NO: 1-7-1150-05-02071		REV: 02		MATERIAL SPEC		ITEM NO	

