

10/51190-000-A-2
DRAWING ON

ALL DIMENSIONS ARE IN MILLIMETRES. FOR TOLERANCES OF UNTOLERANCED DIMENSIONS DURING MANUFACTURE REFER RELEVANT QCP / QP

✓/12.5/ 3.2/

∅170-H11	+0.250
	0
∅156-h11	-0.290
	0
∅89-H7	+0.035
	0

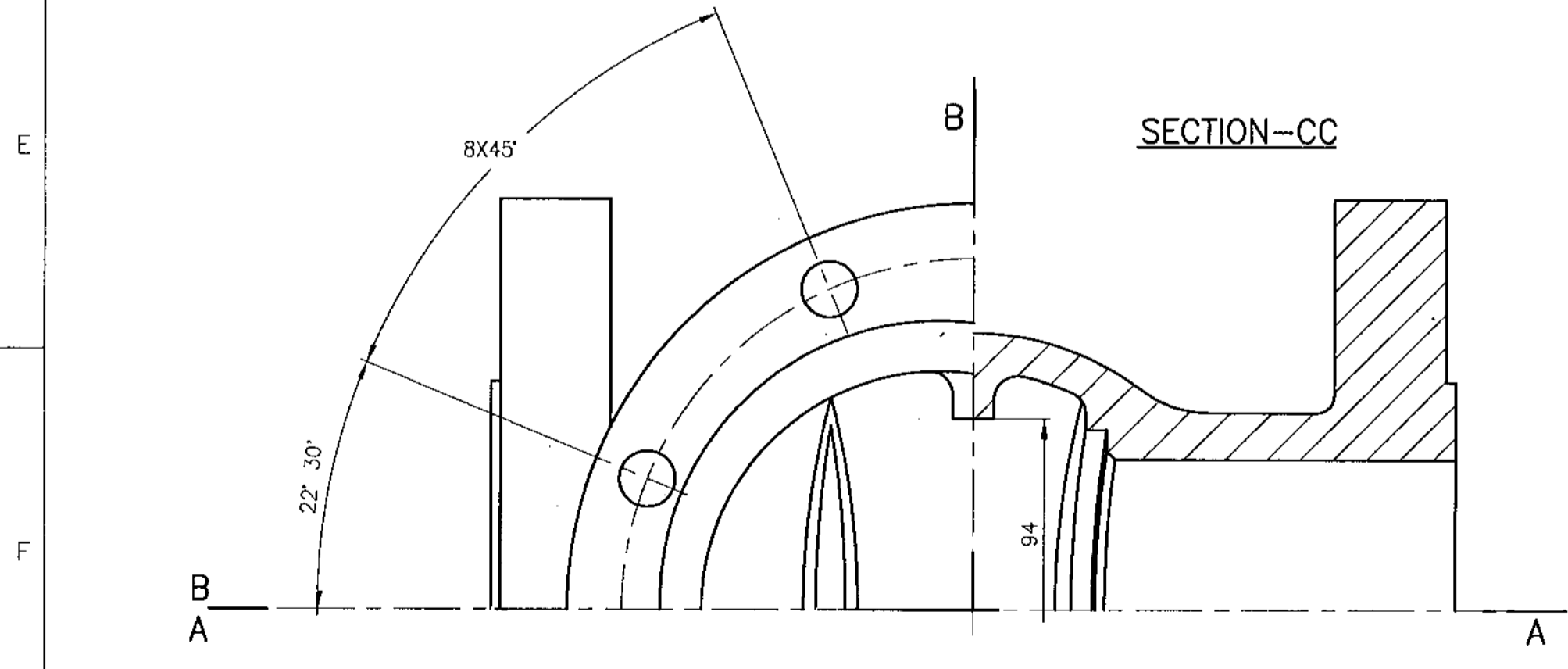
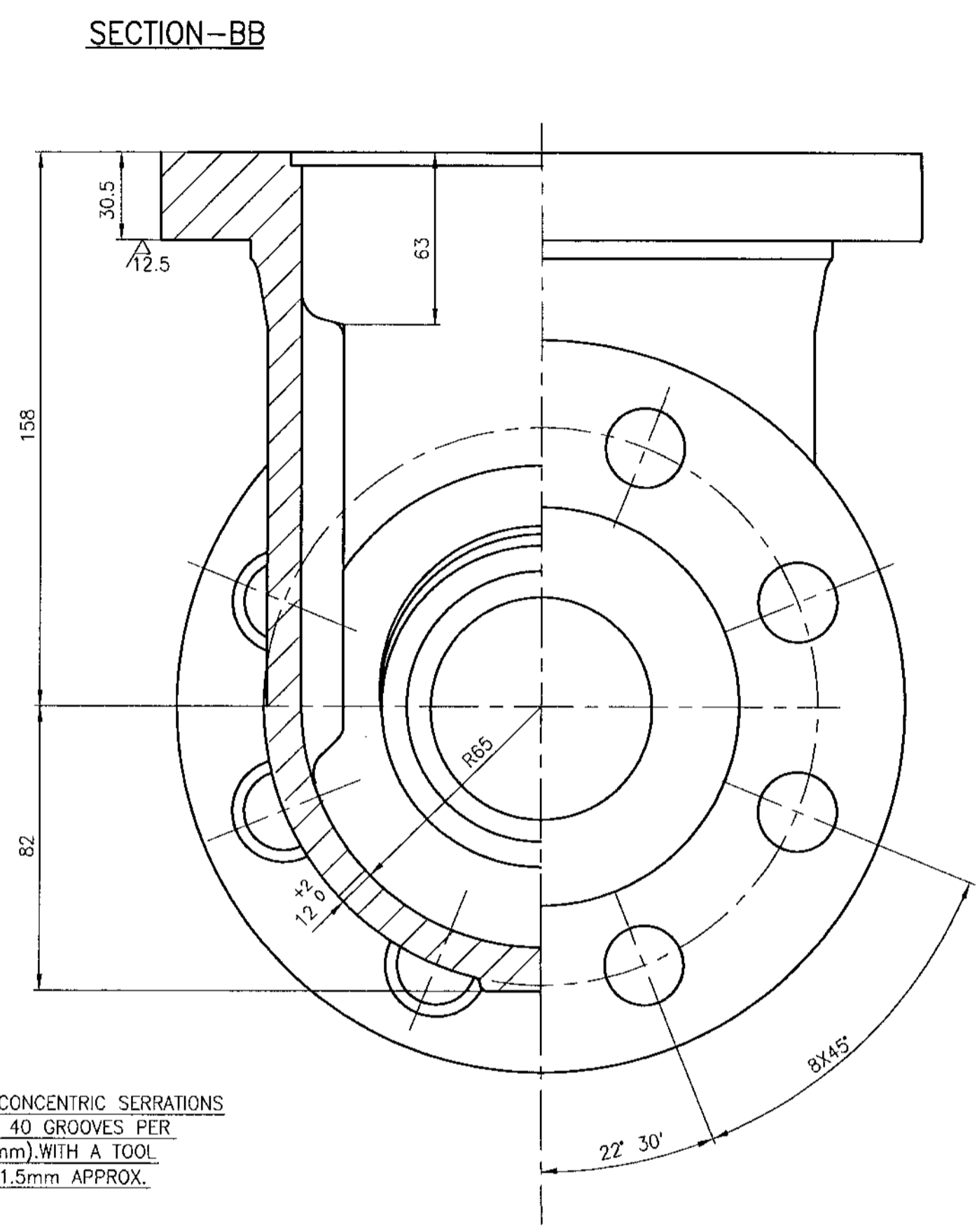
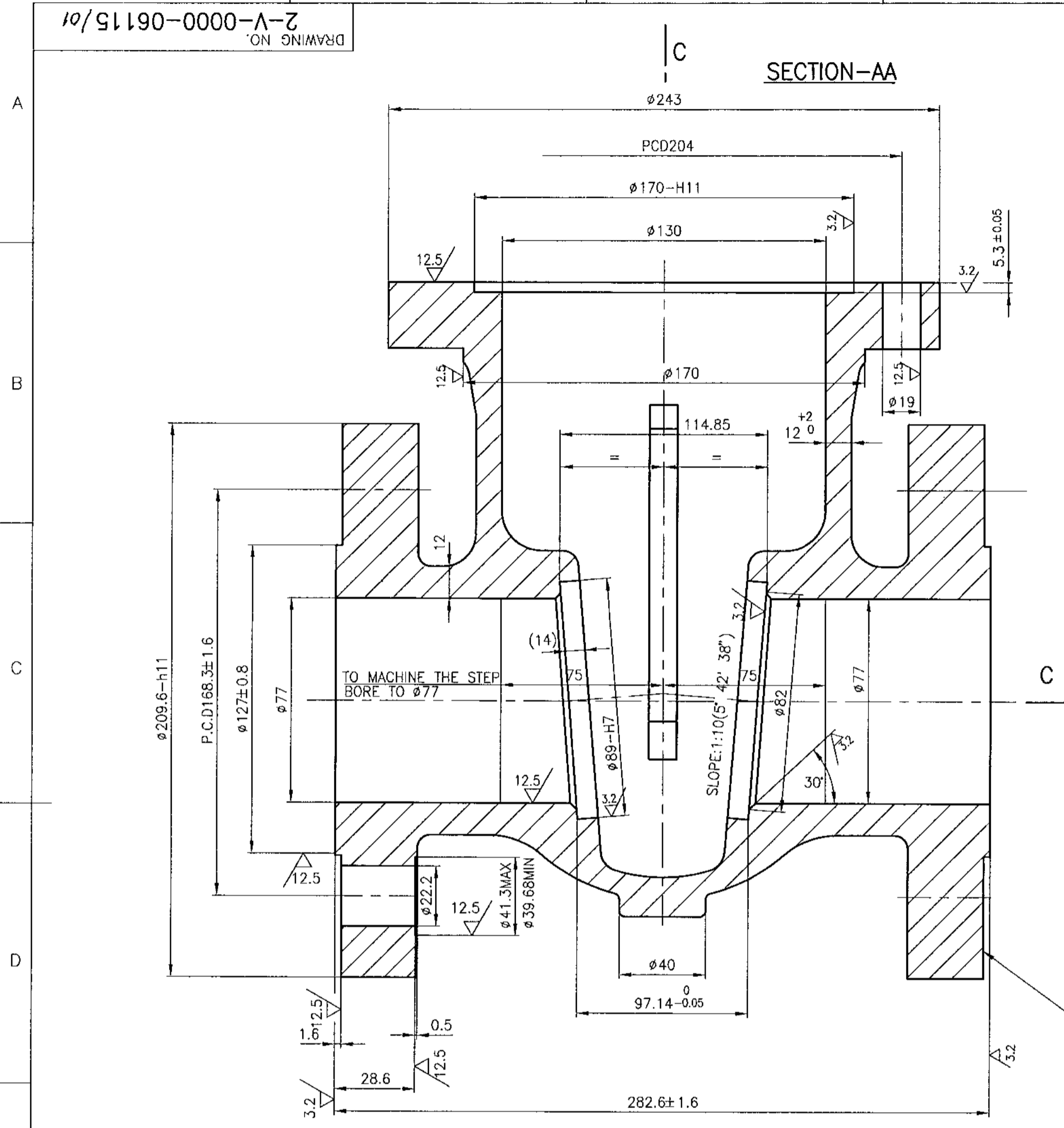

SPIRAL OR CONCENTRIC SERRATIONS WITH 24 TO 40 GROOVES PER INCH (25.4mm). WITH A TOOL RADIUS OF 1.5mm APPROX.

2	CASTING DRG.No. 2.V.N373.06013R	92 200 465	A351-CF8M	SH	46	30.9	40.0	2.V.N373.06115/931063570000	-
1	CASTING DRG.No. 2.V.N364.06013R	92 200 437	A351-CF8	SH	46	30.9	40.0	2.V.N364.06115/931063560000	-
SLNO.	DESCRIPTION	MATL CODE	MATL SPECN	HEAT TREATMENT	SCRAP SORT	NET WT (kg)	GROSS WT (kg)	DRAWING No	ITEM No

TYPE OF PRODUCT OR NAME OF CUSTOMER/PROJECT

	DRN	K.P.LEON	SIGN	DATE	NO. OF VAR.
	CHD	N.DHANAPAL		06.07.96	
	APPD	K.S.RAMAN		09.07.96	

DEPT VL	SCALE	WEIGHT (KG)	REFERENCE INFORMATION	NO. OF ITEMS
CODE 320	NTS		CAD REF:C206115	

TITLE	CARD CODE	DRAWING NO.	REV
BODY (3"-300C FL)	U 01	2-V-0000-06115	01

REV	DATE	ALTERED T.L.L.G
01	15.9.98	CHD & APPD
ZONE	ITEM NO. DELETED	
REFER DCN. CS:0924		

CAUTION: The information on this document is the property of BHARAT HEAVY ELECTRICALS LTD. It must not be used directly or indirectly in any way detrimental to the interest of the company.

