

THE INFORMATION ON THIS DOCUMENT IS THE PROPERTY OF BHARAT HEAVY ELECTRICALS LIMITED. IT MUST NOT BE USED DIRECTLY OR INDIRECTLY IN ANY WAY DETRIMENTAL TO THE INTEREST OF THE COMPANY.

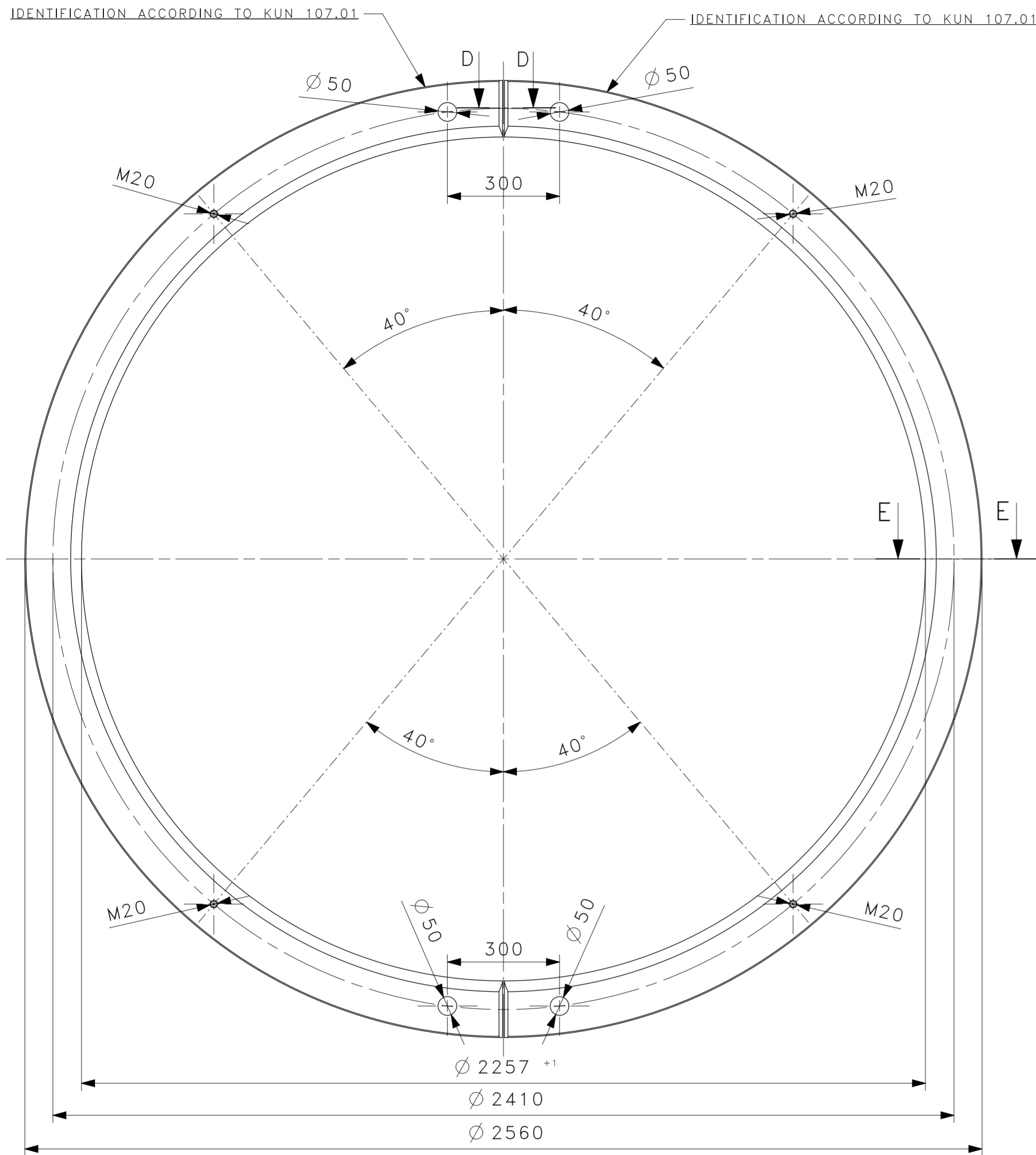

SCALE 1:10

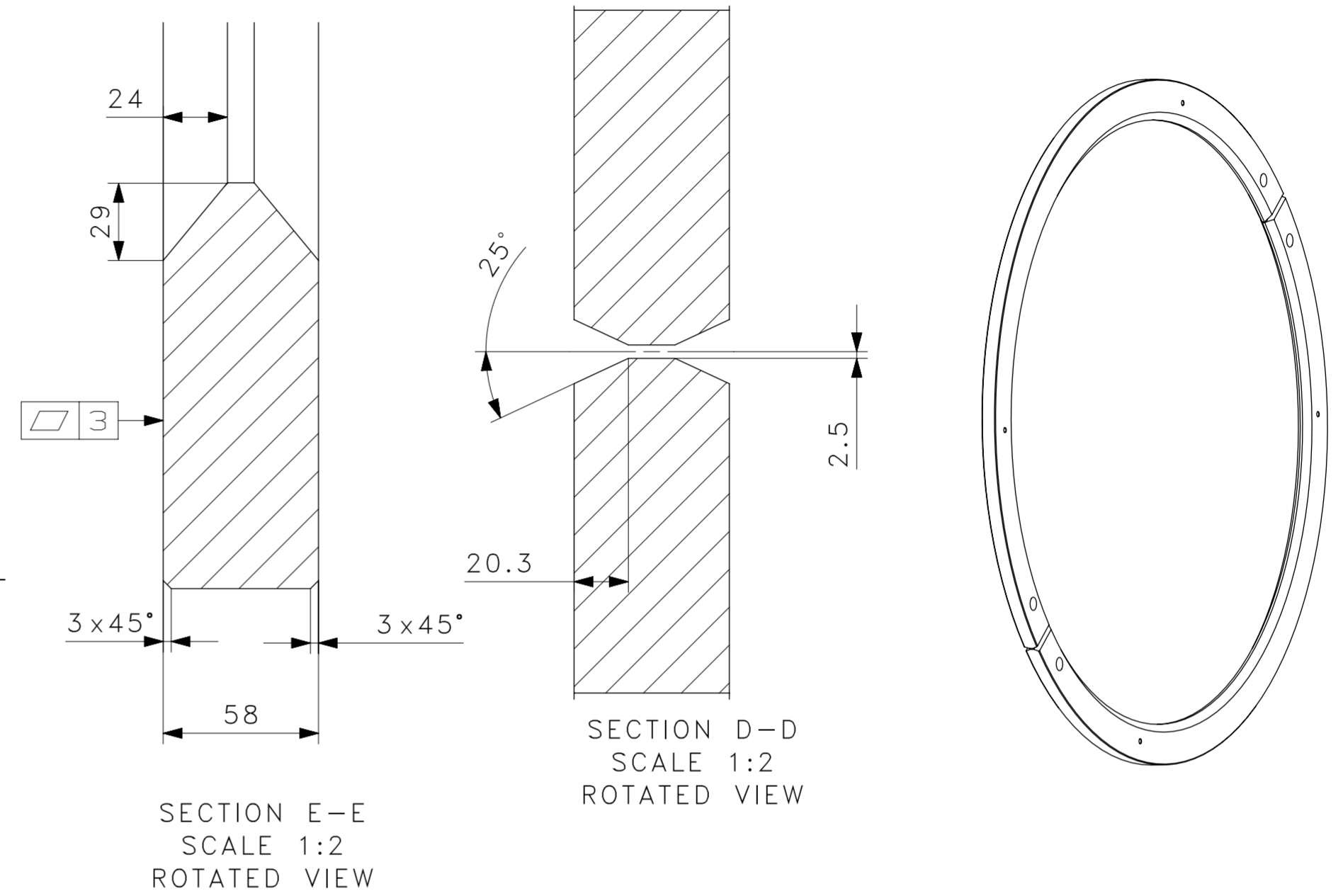

SECTION E-E
SCALE 1:2
ROTATED VIEW

SECTION D-D
SCALE 1:2
ROTATED VIEW

ITEM NO.	DESCRIPTION	DRAWING NO.	VAR. NO.	RAW MATERIAL SIZE OR CASTING DRG. NO. OR FORGING DRG. NO.	MATERIAL CODE	NET WT.	GROSS WT.
							1
					MATERIAL SPECN.	QUANTITY	

THE FOLLOWING CONDITIONS APPLY EXCEPT OTHERWISE STATED...

- REF. TO HY0230261 FOR UNSPECIFIED TOLERANCES.
- CHAMFER M/CD SHARP EDGES 1.2 TO 1.0 AT 45°.
- INTERNAL M/CD CORNER RADI 1 TO 0.7.
- THE SURFACE ROUGHNESS WHEREVER NOT SHOWN SHALL BE TAKEN FROM THE SURFACE ROUGHNESS SHOWN OUT SIDE BACK SLASHES GIVEN AT THE TOP MOST RIGHT CORNER OF THE DRG.

TYPE OF PRODUCT OR NAME OF CUSTOMER/PROJECT: TARI 930-30P

DRN.	A PRAMODH	SIGN.		DATE	11.12.15	NO. OF VAR.	
CHD.	M ASIM				11.12.15		N.A
APPD.	K C PANDA				11.12.15		
DEPT.	EME	SCALE	1:10	WEIGHT (kg)	475.67	REF. TO ASSY. DRG.	ITEM NO. 20
CODE	425					11350431152	
TITLE: CORE BACK RING MIDDLE ASSEMBLY						DRAWING NO. 21350431060	REV. 00
						SHEET NO. 01	NO OF SHEETS 01

REV.	DATE	ALTERED	REV.	DATE	ALTERED	REV.	DATE	ALTERED
		CHECKED			CHECKED			CHECKED
		APPD.			APPD.			APPD.
ZONE			ZONE			ZONE		