

DRG. NO. 14632150038

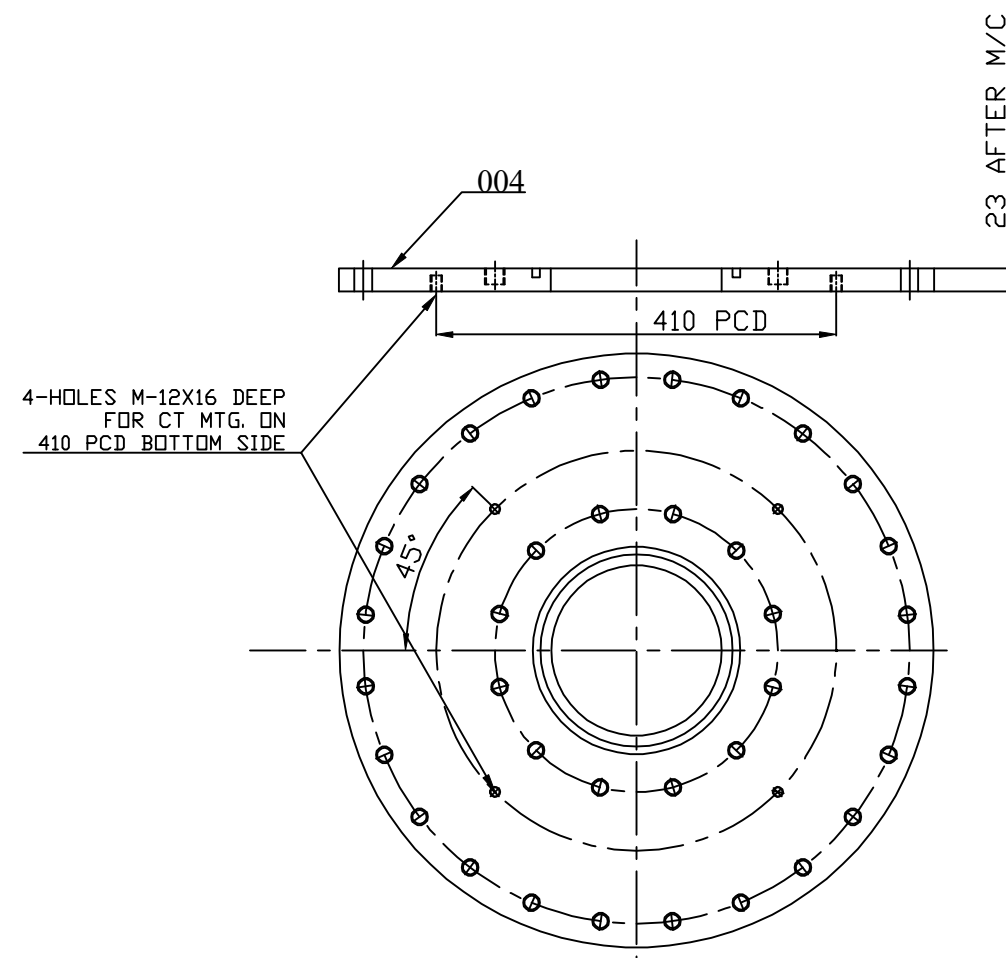

DETAIL-Z

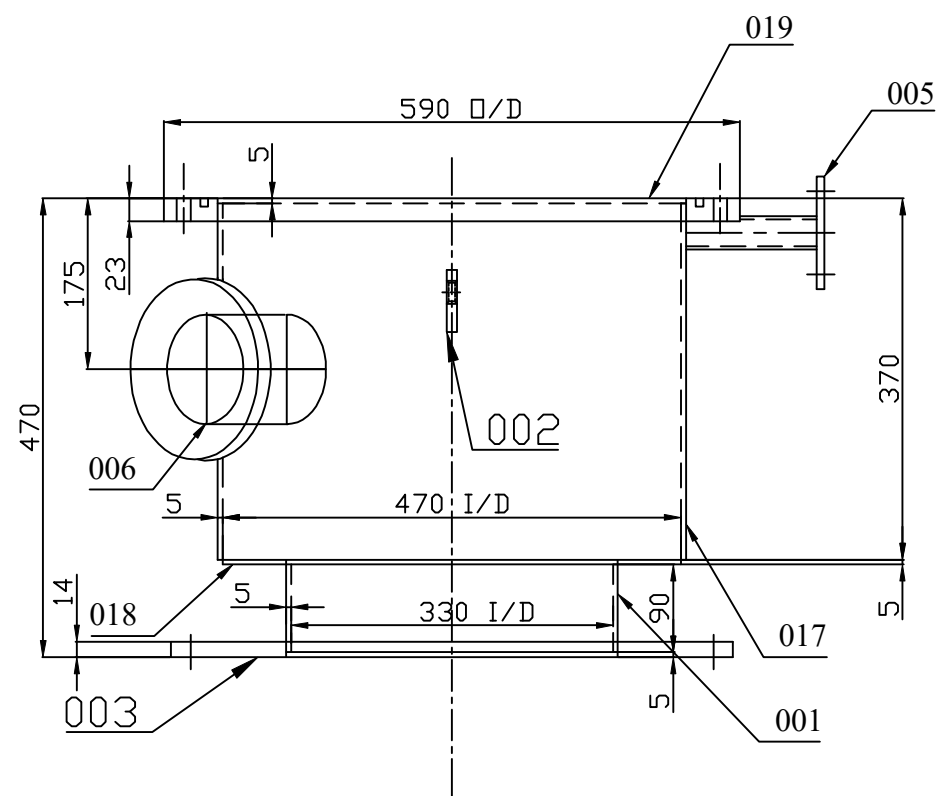
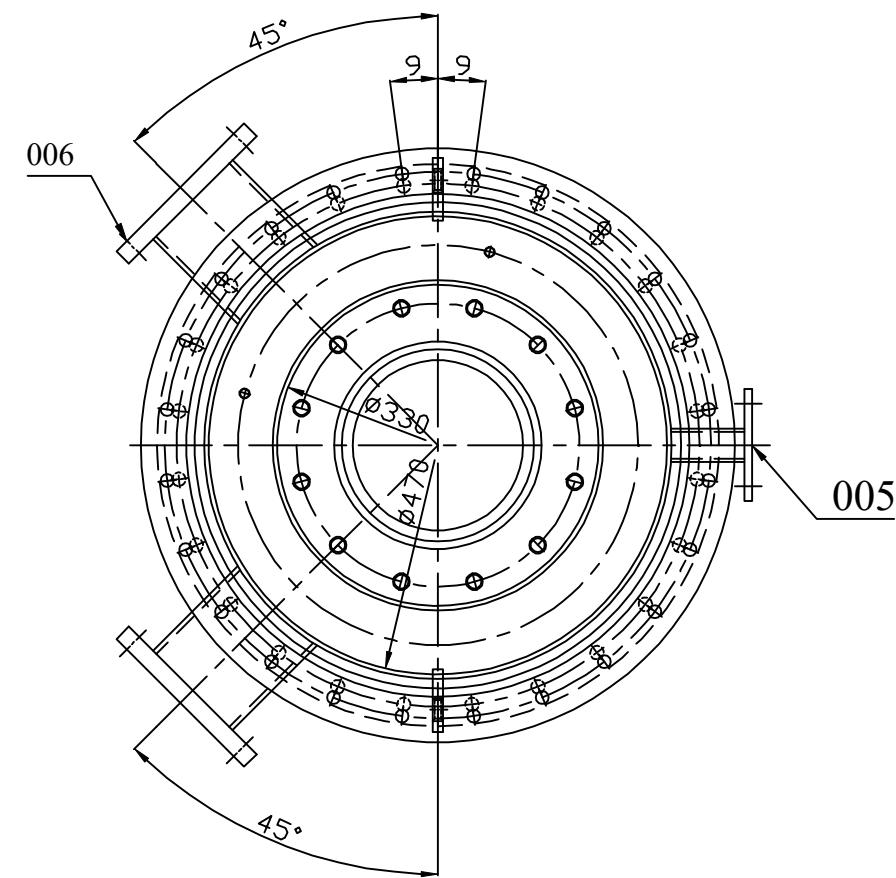

VAR. 00 FOR I.V. PHASE-2U,2V,2W.

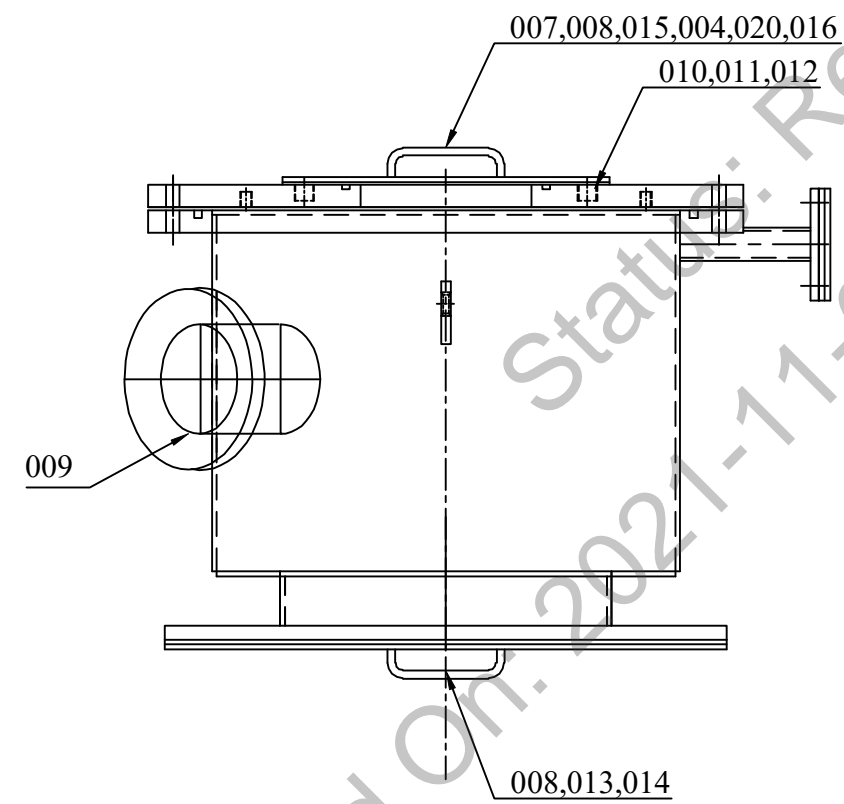

VAR. 01 FOR I.V. PHASE-2U,2V,2W.

NOTES:-

1. ALL WELDS TO BE 5 DELTA UNLESS OTHER WISE STATED.
2. FOR PAINTING INSTRUCTION REFER TOP TANK ASSY. DRG. NO. 04631650032
3. FOR GENERAL NOTES REFER DRG. NO. 14991500007
4. QTY. CALLED IN B.O.M. IS FOR ONE ASSY. ONLY.
5. FLATNESS OF MACHINED SURFACE MUST BE MAINTAINED WITHIN THE TOLERANCE OF  $\pm 0.25$ MM
6. FOLLOWING IS TO PAINTED ON TURRET BEFORE DISPATCH NEW GASKETS AND SEQUENTIAL TIGHTENING SHALL BE ENSURED ON ERECTION.
7. VAR.00 IS I.V. TURRET ASSY. FOR PHASE 2U,2V,2W.
8. VAR.01 IS BLANKING & FITTING OF I.V. TURRET ASSY. FOR PHASE 2U,2V,2W.

DIMNS. TABLE - A

IT. NO.	A	B	C	D	D4	E	G	N	N2	P	P2	S°	T	T1	Q°	M	Z	X	Y
003	344	470	20	14	---	---	---	---	---	420	---	---	16	14	9	---	---	---	---
004	175	590	290	---	---	216	---	12	---	14	---	9	---	---	15	12	550	20	---
013	---	---	---	---	14	---	470	---	20	---	420	9	---	---	---	---	---	---	---
014	470	344	420	14	---	---	---	20	---	---	---	---	6	---	9	---	---	---	---
015	---	---	---	---	14	---	335	---	12	---	290	15	---	---	---	---	---	---	---
019	482	590	---	---	---	516	---	---	---	14	---	9	---	---	---	---	550	20	---

APPROXIMATE WEIGHTS & VOLUME

VAR. NO.	WT. IN KGS.	VOLUME IN LTRS.
VAR.00	72.00	70.00
VAR.01	90.00	---
TOTAL	162.00	70.00

FOR B.O.M REFER E-B.O.M OF DRG.NO- 1 463 21 50 038.

ADDITIONAL INFORMATION 72589A17200		TYPE OF PRODUCT OR 160 MVA,220/132/11 KV AUTO TRFR	
STATUS OF DRAWING		NAME OF CUSTOMER/PROJECT M/S:- UPPTCL	
DISTRIBUTION OF PRINTS		BHARAT HEAVY ELECTRICALS LTD. JHANSI	
REV	DATE	ALTERED	CHECKED
01	20/10/2020	CHECKED	SHJ
DEPT-TRE UN.TOL. DIM. C/M/F		SCALE WEIGHT (KGS) REF. TO ASSY. NO. ITEM NO. OF ITEM	
CODE-406		DRAWING NO. 14632150038	
TITLE I.V.TURRET ASSY.		REV. 01	
SHT NO		NO OF SHT	

INVENTORY NO. ZONE

REV	DATE	ALTERED	CHECKED	APPROVED	REV	DATE	ALTERED	CHECKED	APPROVED	REV	DATE	ALTERED	CHECKED	APPROVED	REV	DATE	ALTERED	CHECKED	APPROVED	REV	DATE	ALTERED	CHECKED	APPROVED	REV	DATE	ALTERED	CHECKED	APPROVED																														
1					2					3					4					5					6					7					8					9					10					11					12				