

DETAIL-C

SECTION-DD

DETAIL-F

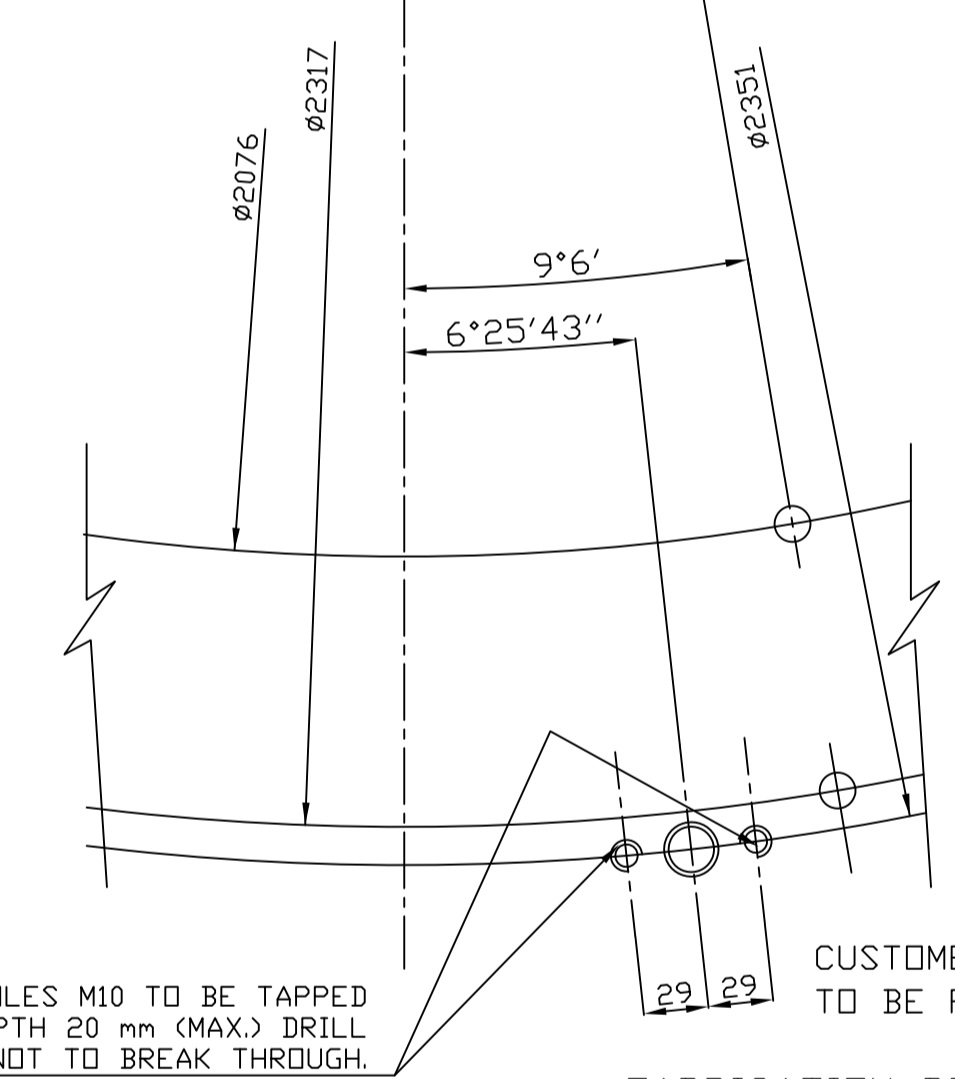
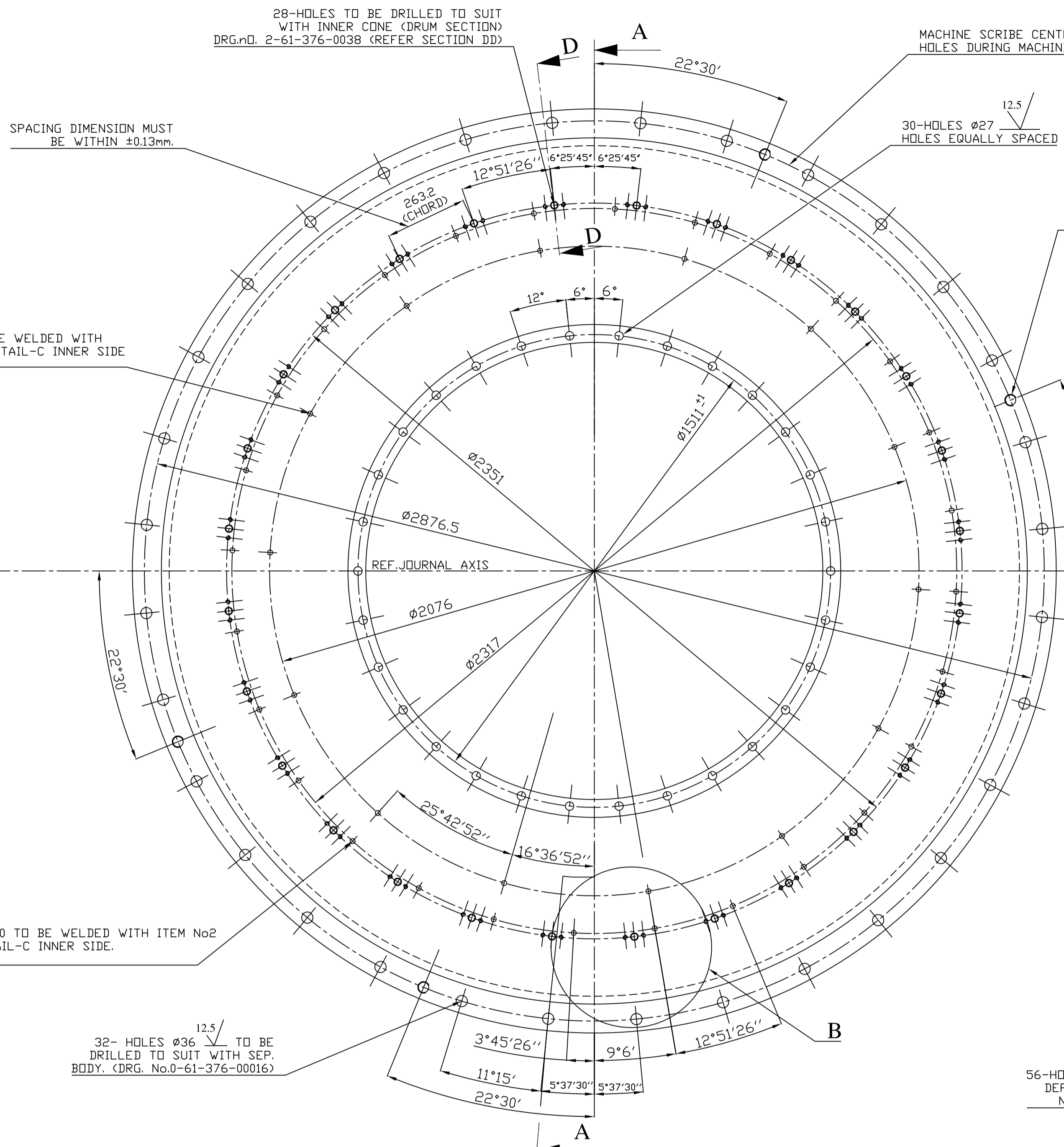

DETAIL-B

FABRICATION DRG. No.1-61-376-01307

ITEM NO.	DESCRIPTION	DRAWING NO.	VAR. NO.	RAW MATERIAL SIZE OR CASTING DRG. NO. OR FORGING DRG. NO.	MATERIAL CODE	NET WT.	GROSS WT.	QUANTITY
03	WELD STUD .M16 X 35				HY7145101661	0.05		
					AA7145101			42
02	PRESSING (FOR SEPARATOR TOP)	4-61-376-00148				1566.00		1
01	FLANGE	4-61-376-00147				250.00		1

THE FOLLOWING CONDITIONS APPLY EXCEPT OTHERWISE STATED.

- REF. TO HY0230261 FOR UNSPECIFIED TOLERANCES.
- CHAMFER M/C.D. SHARP EDGES 1.2 TO 1.0 AT 45°.
- INTERNAL M/C.D. CORNER RADII 1 TO 0.7
- THE SURFACE ROUGHNESS WHERE-EVER NOT SHOWN SHALL BE TAKEN FROM THE SURFACE ROUGHNESS SHOWN OUT SIDE THE BACK SLASH GIVEN OR THE TOP MOST RIGHT CORNER OF THE DRG.

TYPE OF PRODUCT: 803 XRP BOWL MILL
 NAME OF CUSTOMER/PROJECT: BHARAT HEAVY ELECTRICALS LIMITED HYDERABAD

DRN.	E.M.ASHOK	SIGN.		DATE	5-06-01	NO OF VAR.	
CHD.	S.G				5-06-01		
APPD.	K.M.RAD				5-06-01		

DEPT. 446 UNIT. DIMS. GR. 6/M/F SCALE 1:10 WEIGHT (KG) 1758 REF. TO ASSY DRG. ITEM NO. 17

TITLE: **SEPARATOR TOP ASSY**

DRAWING NO. 1-61-376-00023 SHEET NO. 17 NO OF SHEETS 17

REV.	DATE	ALTERED	ZONE	REV.	DATE	ALTERED	ZONE	REV.	DATE	ALTERED	ZONE	REV.	DATE	ALTERED	ZONE
17	15.3.07	CHD./APPD. AS SG		16	8.11.06	CHD./APPD. AS SG		15	12.5.06	CHD./APPD. AS SG		14	5.8.01	CHD./APPD. S.G K.M.R.	
		M/C UPTD Ø2810 ADDED IN SEC AA. DIM 19 WAS 12.				WELD STUD M16X35 WAS M16X30.								DRG. REDRAWN ITEM 03 MAT CODE WAS BA9617684047 FABRICATION DRG No. ADDED.	

INVENTORY NO. SIGN. AND DATE REF. DRG. NO. COMPUTER FILE NAME 16100023 THE INFORMATION ON THIS DOCUMENT IS THE PROPERTY OF BHARAT HEAVY ELECTRICALS LIMITED. IT MUST NOT BE USED DIRECTLY OR INDIRECTLY IN ANY WAY DETERIMENTAL TO THE INTEREST OF THE COMPANY.

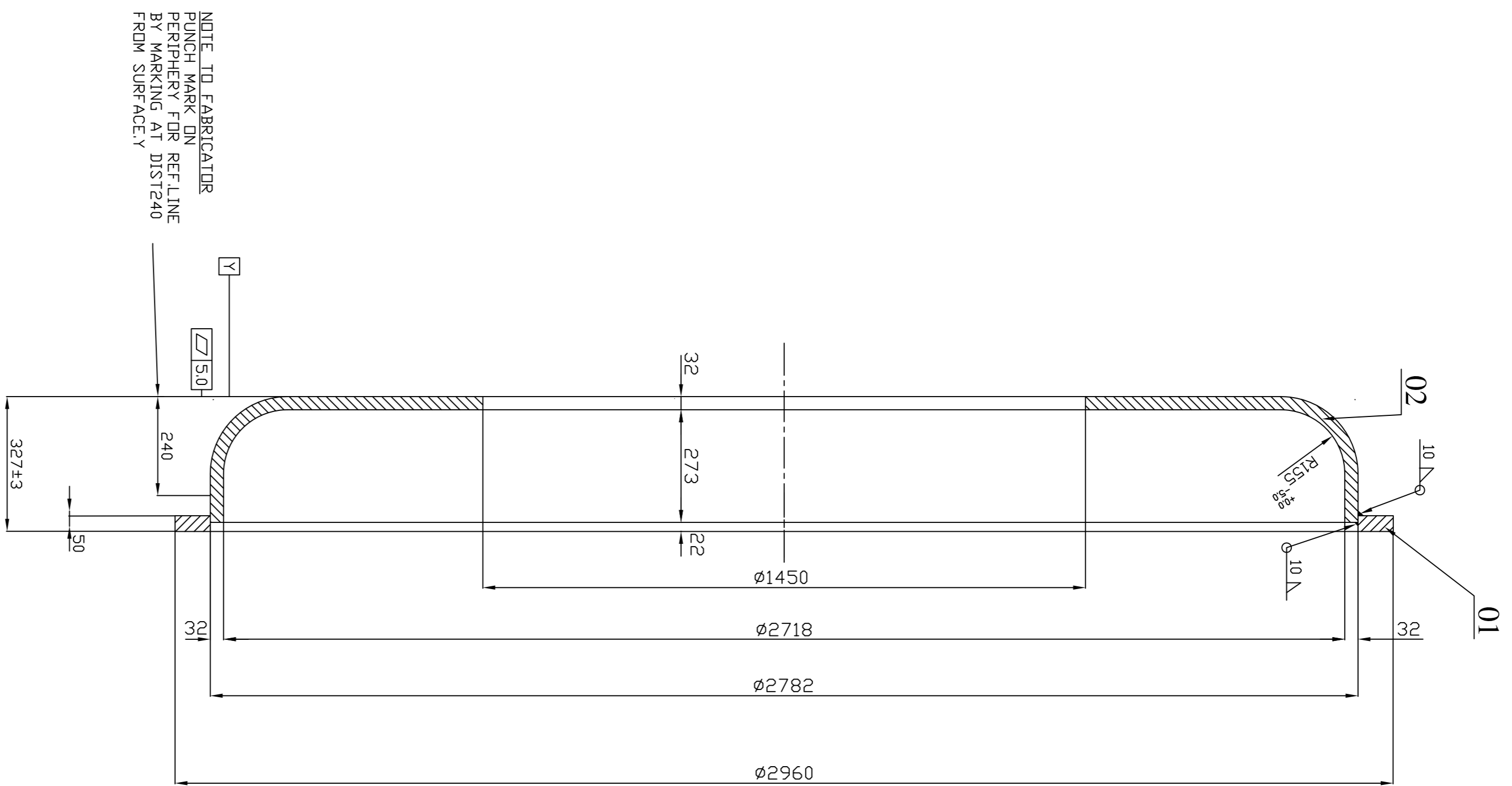

SECTION-AA

NOTE: TO FABRICATOR
PUNCH MARK TO BE TAKEN
PERIPHERY FOR REFERENCE
BY MARKING AT DISTANCE
FROM SURFACE

NOTE:
1. MINIMUM ABSOLUTE THICKNESS OF 32 PLATE
AT ANY POINT AFTER PRESSING SHOULD NOT BE LESS THAN 28.5 mm
2. CUSTOMER APPROVED QUALITY PLAN
TO BE FOLLOWED.
3. FOR MACHINING REF DRG NO: 1-61-376-00023/1-61-380-01447.

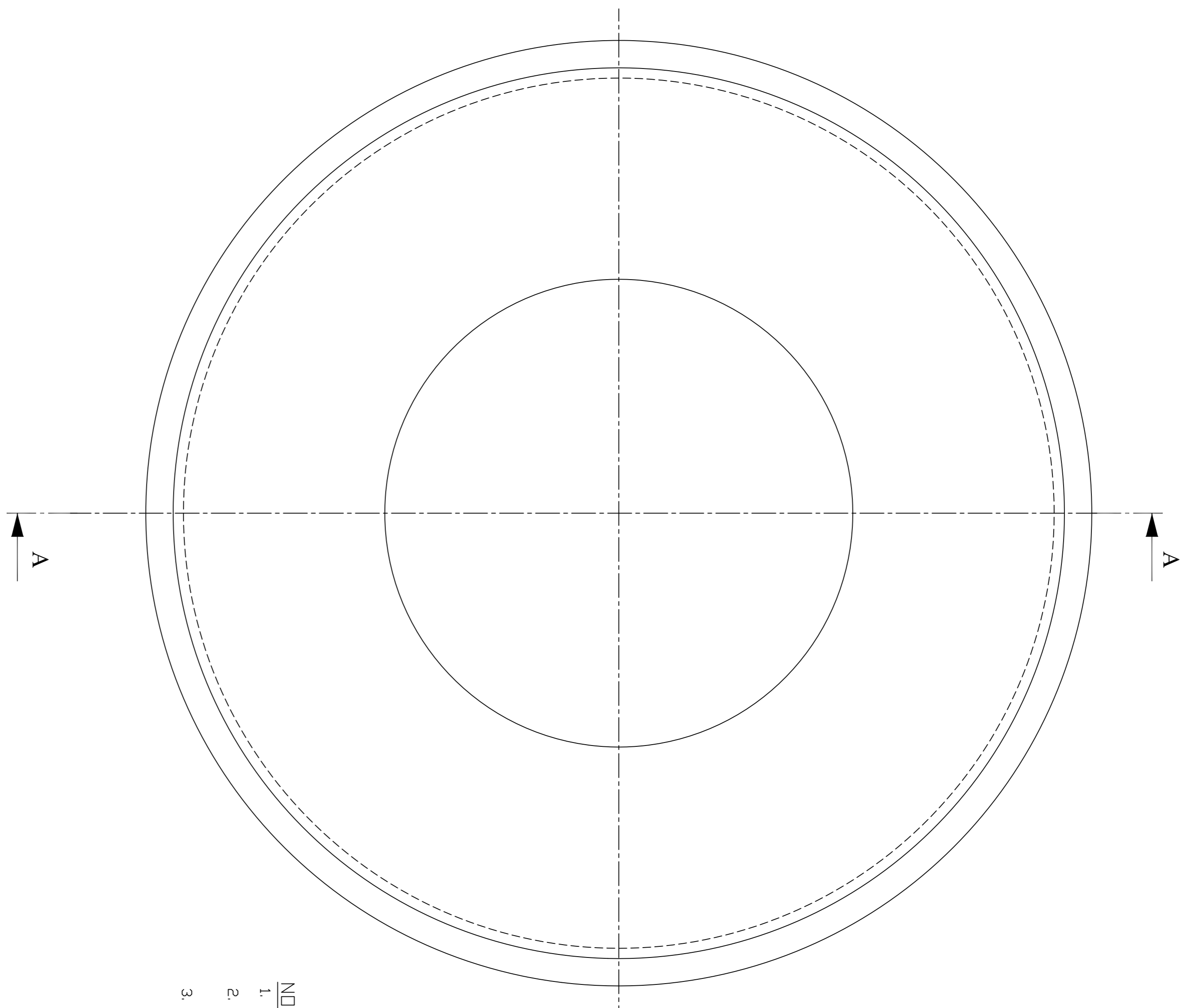

ITEM NO.	DESCRIPTION	DRAWING NO.	VAR. NO.	RAW MATERIAL, SIZE OR CASTING DRG. NO. OR FORGING DRG. NO.	MATERIAL CODE	NET WT.	GROSS WT.	QUANTITY
02	PRESSING (FOR SEPARATOR TOP)	4-61-376-00148				1566.00		1
01	FLANGE	4-61-376-00147				312.00		1

THE FOLLOWING CONDITIONS APPLY EXCEPT OTHERWISE STATED.

- REF. TO HYDROGEN FOR UNSPECIFIED TOLERANCES.
- CHAMFER M/C/D SHARP EDGES 1:2 TO 1:0 AT 45°.
- INTERNAL M/C/D CORNER RADIUS 1 TO 0.7
- THE SURFACE ROUGHNESS WHERE-EVER NOT SHOWN SHALL BE TAKEN FROM THE SURFACE ROUGHNESS SHOWN ON THE BACK SLASH GIVEN OR THE TOP MOST RIGHT CORNER OF THE DRG.

DEPT.	INITL. DRG. OR	SCALE	WEIGHT (KG)	ITEM NO.	DATE
446	4/M/7	1:10	1878.0	5-06-01	5-06-01

TYPE OF PRODUCT: 803 XRP BOWL MILL
NAME OF CUSTOMER/PROJECT: BHARAT HEAVY ELECTRICALS LIMITED HYDERABAD

NAME: E.MASHTIK
SIGN: [Signature]
DATE: 5-06-01

CHD: S/G
APPD: K.M.RAD
REF. TO ASSY DRG. 5-06-01

TITLE: SEPARATOR TOP FABRICATION
GROSS DRAWING NO. 1-61-376-01307
SHEET NO. 01

REV.	DATE	ALTERED	REV.	DATE	ALTERED	REV.	DATE	ALTERED
01	13.6.05	CHD/APPD	01	13.6.05	CHD/APPD	01	13.6.05	CHD/APPD

COMPUTER FILE NAME: 16101307

REV.	DATE	ALTERED	REV.	DATE	ALTERED
01	27.08.2013	327±3 & 32	01	27.08.2013	327±3 & 32

CHANGES: DIMS 2782, 327±3 & 32 WERE 2768, 320±3 & 25 RESPLY. WT WAS 1540.

REV.	DATE	ALTERED	REV.	DATE	ALTERED
01	13.6.05	CHD/APPD	01	13.6.05	CHD/APPD

61410-083-19-1 DR. SHRI

FIRST ANGLE PROJECTION

ALL DIMENSIONS ARE IN MM

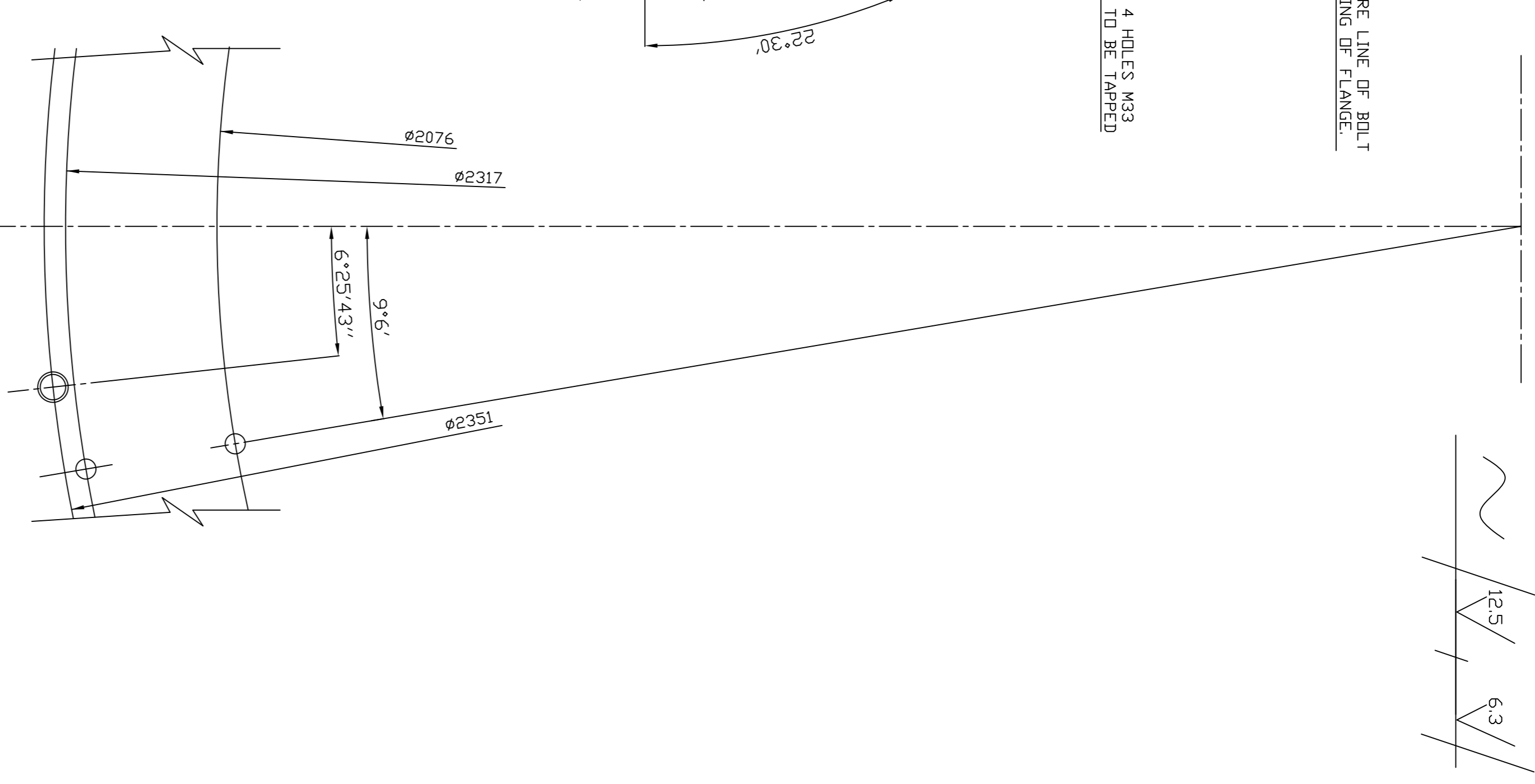
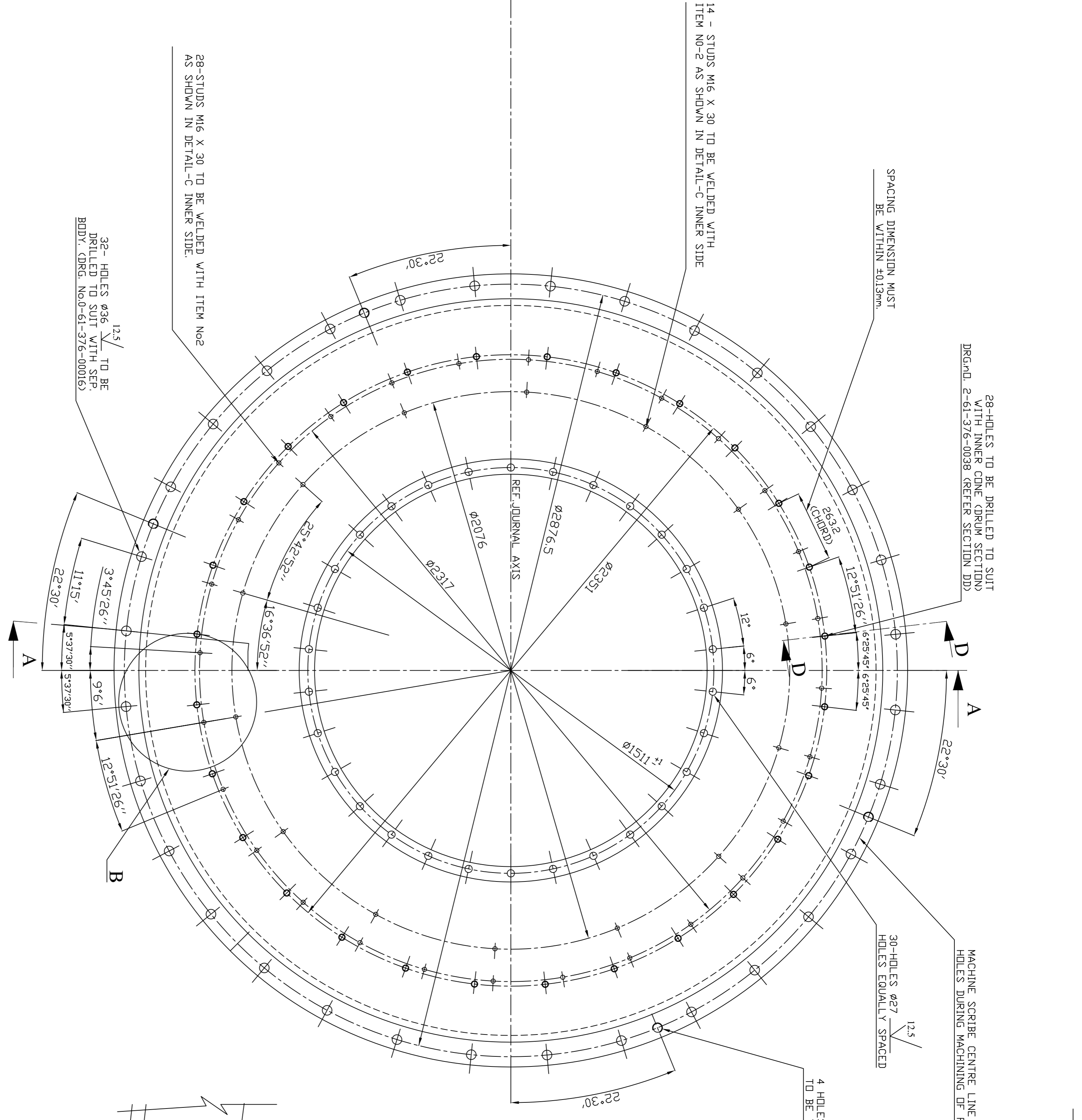
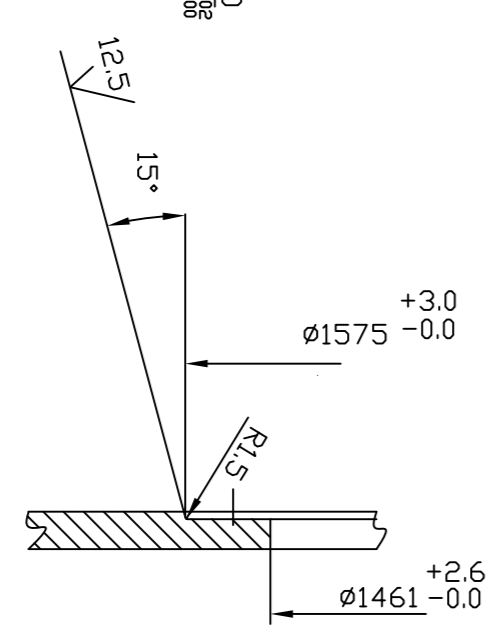
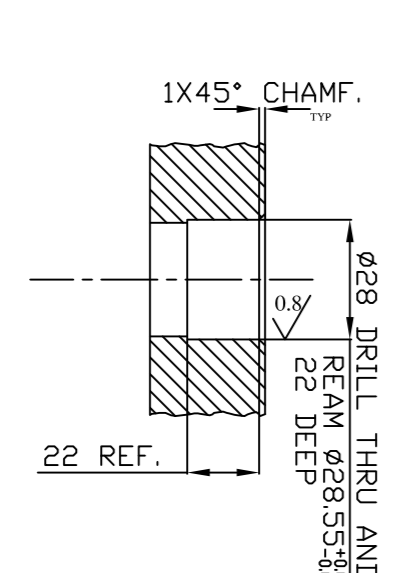
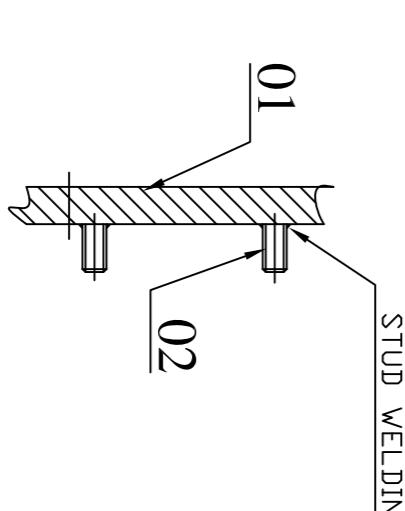
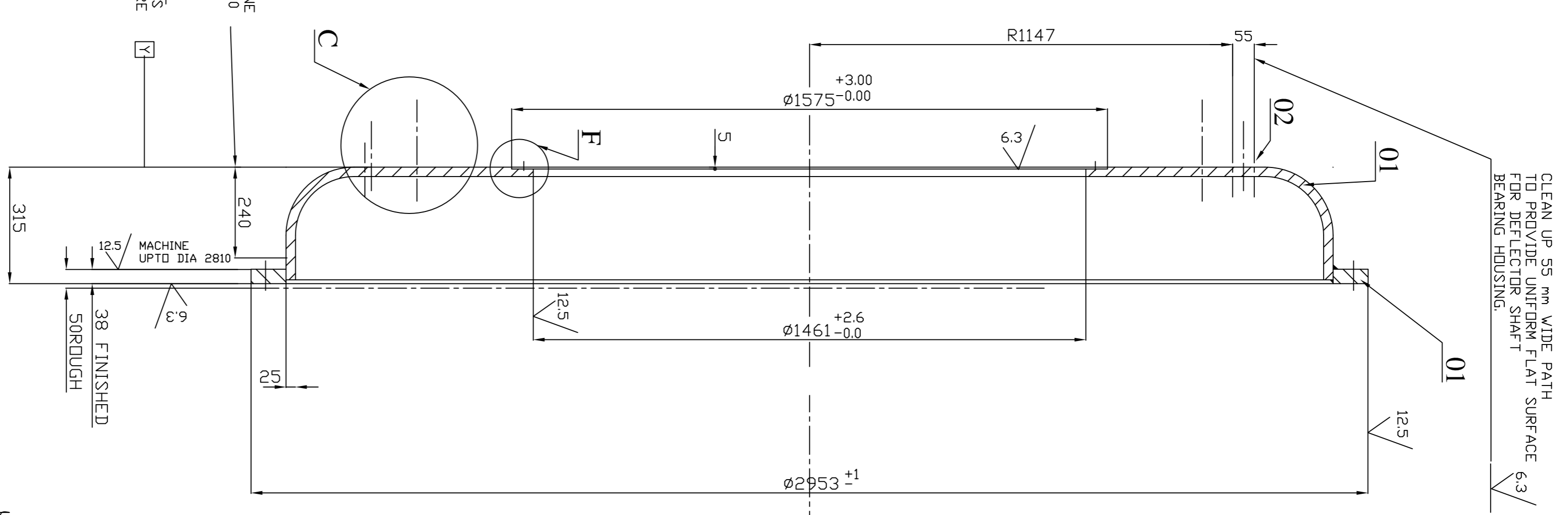

DETAIL-B

FABRICATION DRG. No.1-61-376-01307
CUSTOMER APPROVED QUALITY PLAN TO BE FOLLOWED.

ITEM NO.	DESCRIPTION	DRAWING NO.	VAR. NO.	RAW MATERIAL SIZE OR CASTING DRG. NO. OR FORGING DRG. NO.	MATERIAL CODE	NET WT.	GROSS WT.	QUANTITY
01	FABRICATION DRG	1-61-380-01307						1
02	WELD STUD M16 X 30							42

DETAIL-C

SECTION-DD

DETAIL-F

THE FOLLOWING CONDITIONS APPLY EXCEPT OTHERWISE STATED.
1. REF. TO HYDROBOL FOR UNSPECIFIED TOLERANCES.
2. CHAMFER M/C/D SHARP EDGES 1:2 TO 1:10 AT 45°.
3. INTERNAL M/C/D CORNER RADIUS 1 TO 0.7.
4. THE SURFACE ROUGHNESS WHERE-EVER NOT SHOWN SHALL BE TAKEN FROM THE SURFACE ROUGHNESS SHOWN ON THE BACK SLASH GIVEN OR THE TOP MOST RIGHT CORNER OF THE DRG.

DEPT.	INITIALS	DATE	NAME	SIGN.	DATE	IND. OF
DESIGN			E. MASCHOK		13.05.06	VAR.
CHKD.			A. SORJIN		13.05.06	
APPD.			S. GHATGE		13.05.06	

REV.	DATE	ALTERED	ZONE	REV.	DATE	ALTERED	ZONE	REV.	DATE	ALTERED	ZONE
		CHD/APPD.				CHD/APPD.				CHD/APPD.	

TYPE OF PRODUCT	NAME OF CUSTOMER/PROJECT	803 XRP BOWL MILL
SEPARATOR TOP		

DRG. NO.	SCALE	WEIGHT (KG)	REV.
1-61-380-01419	1:10	1785.0	00

SHEET NO.	TOTAL SHEETS
1	12

L4710-083-19-1 DR. SHRI

FIRST ANGLE PROJECTION

ALL DIMENSIONS ARE IN MM

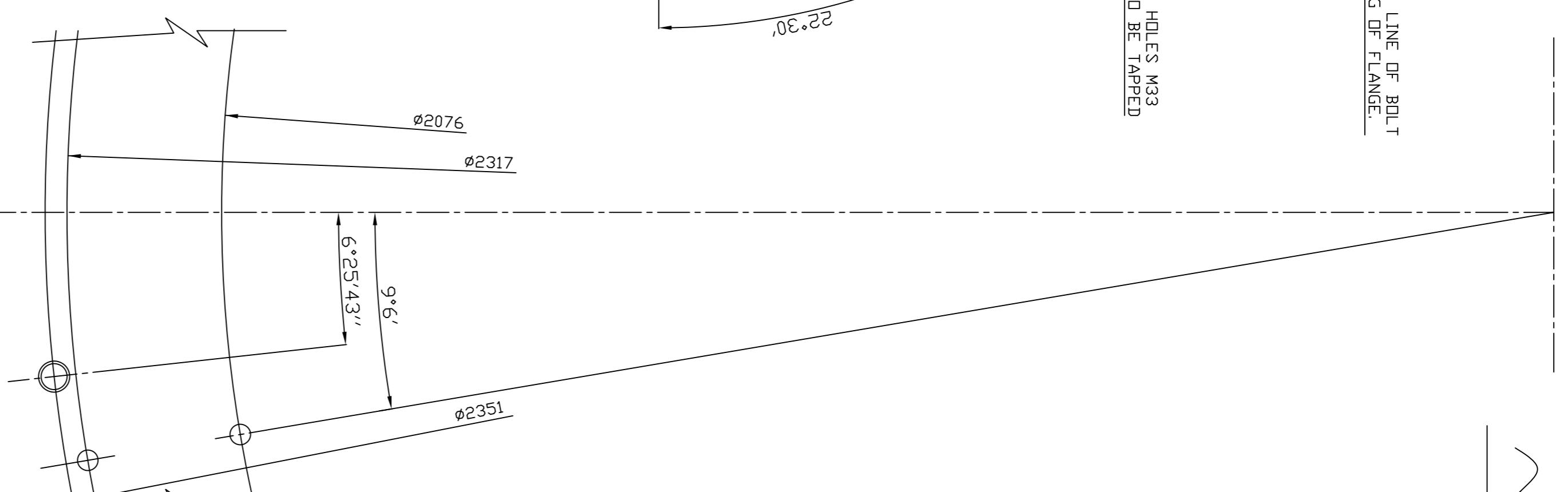
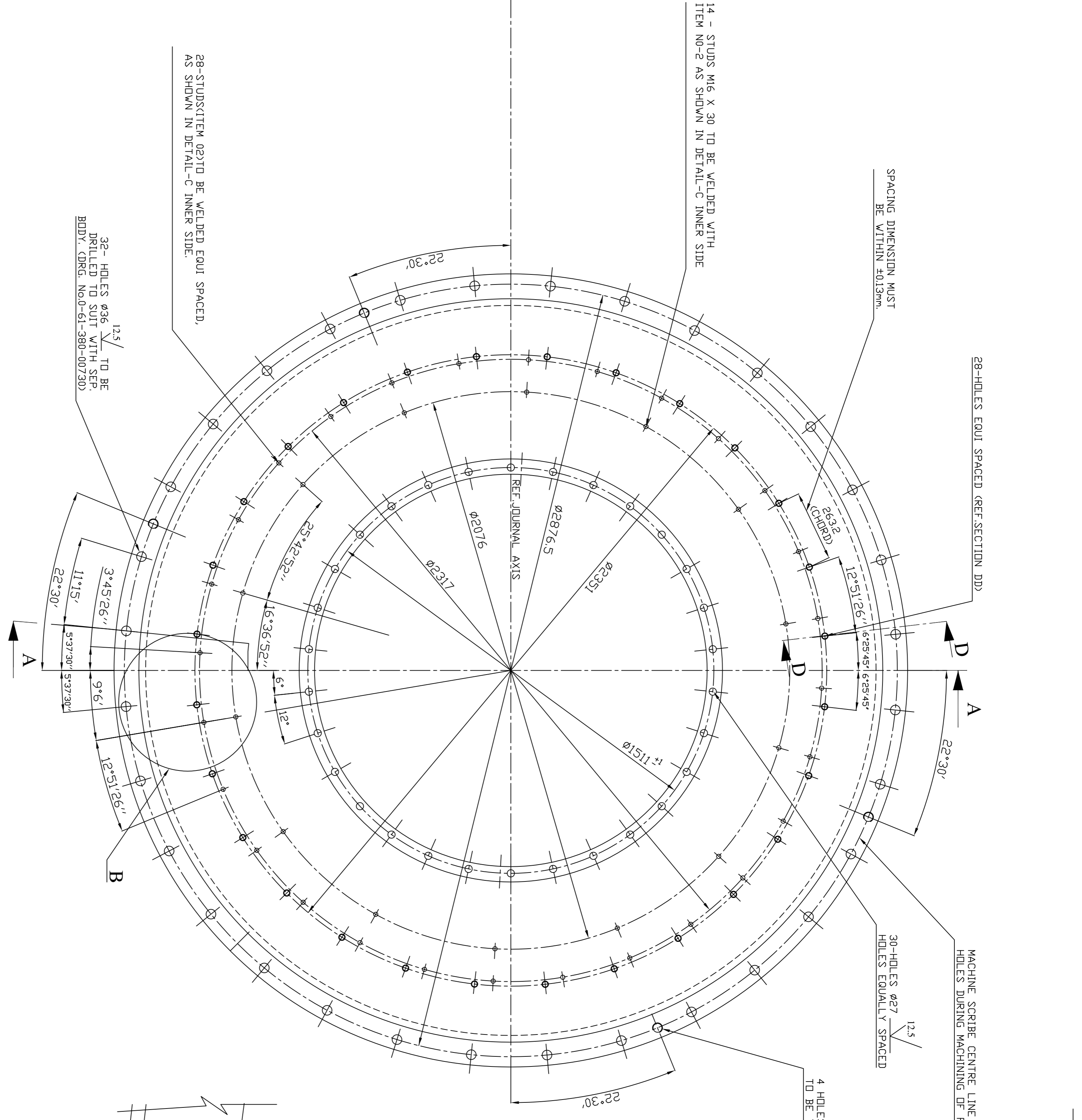
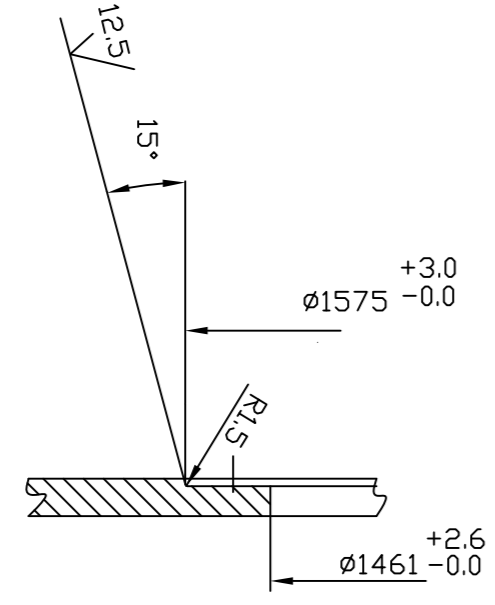
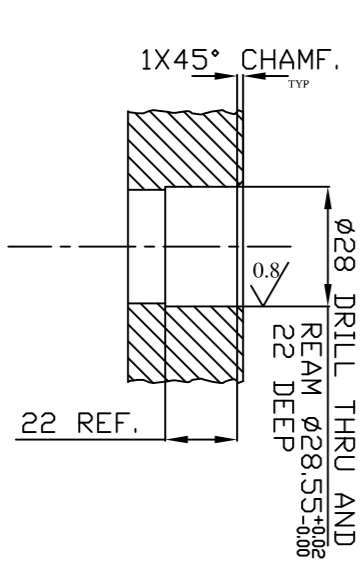
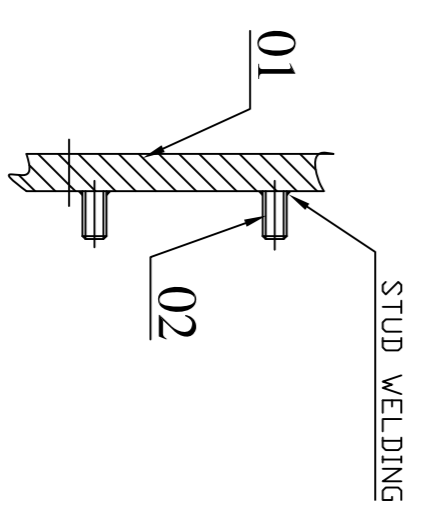
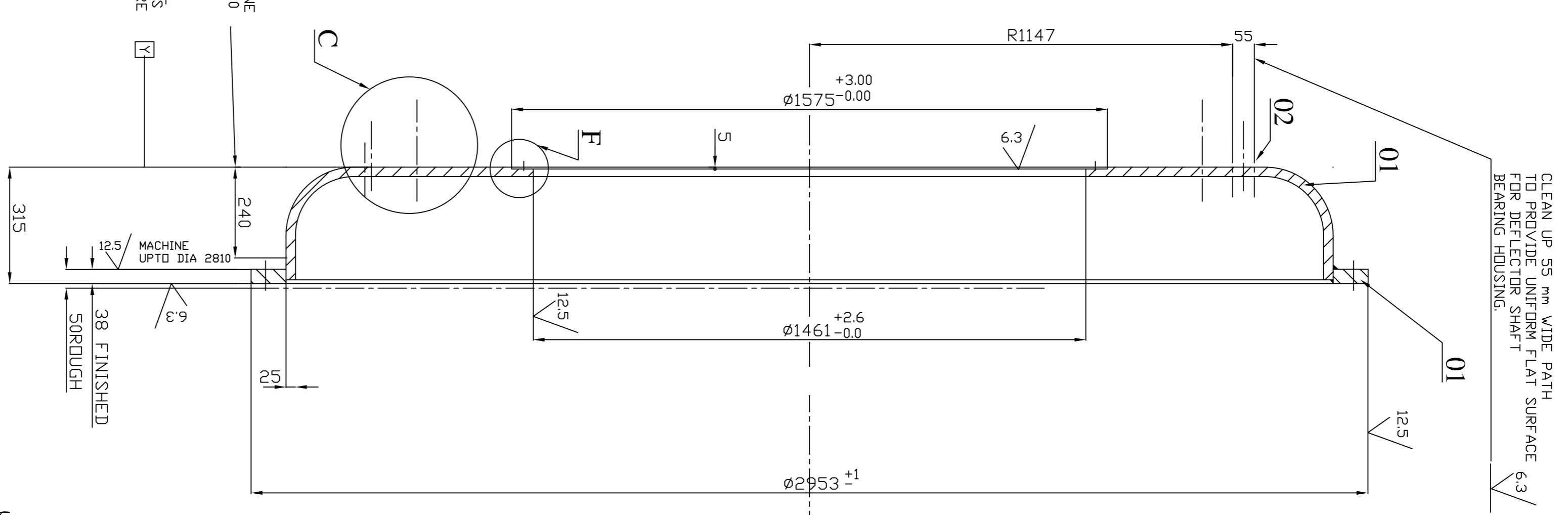

DETAIL-B

FABRICATION DRG. No.1-61-376-01307

ITEM NO.	DESCRIPTION	DRAWING NO.	VAR. NO.	RAW MATERIAL SIZE OR CASTING DRG. NO. OR FORGING DRG. NO.	MATERIAL CODE	NET WT.	GROSS WT.	QUANTITY
01	FABRICATION DRG	1-61-380-01307						1
02	WELD STUD M16 X 30							

DETAIL-C

SECTION-DD

DETAIL-F

THE FOLLOWING CONDITIONS APPLY EXCEPT OTHERWISE STATED.

1. REF. TO HYDRO3861 FOR UNSPECIFIED TOLERANCES.
2. CHAMFER M/C/D SHARP EDGES 1:2 TO 1:0 AT 45°.
3. INTERNAL M/C/D CORNER RADIUS 1 TO 0.7
4. THE SURFACE ROUGHNESS WHERE-EVER NOT SHOWN SHALL BE TAKEN FROM THE SURFACE ROUGHNESS SHOWN ON THE BACK SLASH GIVEN OR THE TOP MOST RIGHT CORNER OF THE DRG.

DEPT.	INITL. DRG. OR SIDE V.	SCALE	WEIGHT (KG)	REF. TO ASSY DRG.	ITEM NO.	INDF. VARS
446		1:10	1785.0			

SEPARATOR TOP

NAME	SIGN.	DATE	INDF. VARS
EMASHDOK		19.4.07	
ASURIN		19.4.07	
SIGHATIE		19.4.07	

CUSTOMER APPROVED QUALITY PLAN TO BE FOLLOWED.

FABRICATION DRG. No.1-61-376-01307

DETAIL-C

SECTION-DD

DETAIL-F

THE FOLLOWING CONDITIONS APPLY EXCEPT OTHERWISE STATED.

1. REF. TO HYDRO3861 FOR UNSPECIFIED TOLERANCES.
2. CHAMFER M/C/D SHARP EDGES 1:2 TO 1:0 AT 45°.
3. INTERNAL M/C/D CORNER RADIUS 1 TO 0.7
4. THE SURFACE ROUGHNESS WHERE-EVER NOT SHOWN SHALL BE TAKEN FROM THE SURFACE ROUGHNESS SHOWN ON THE BACK SLASH GIVEN OR THE TOP MOST RIGHT CORNER OF THE DRG.

DEPT.	INITL. DRG. OR SIDE V.	SCALE	WEIGHT (KG)	REF. TO ASSY DRG.	ITEM NO.	INDF. VARS
446		1:10	1785.0			

SEPARATOR TOP

NAME	SIGN.	DATE	INDF. VARS
EMASHDOK		19.4.07	
ASURIN		19.4.07	
SIGHATIE		19.4.07	

CUSTOMER APPROVED QUALITY PLAN TO BE FOLLOWED.

FABRICATION DRG. No.1-61-376-01307

REV. 03	DATE 12.6.01	ALTERED CHECKED S.G	E.M.ASHOK	REV. 04	DATE 8.12.04	ALTERED CHECKED S.G	REV. 05	DATE 12.5.06	ALTERED CHECKED S.G
		APPROVED K.M.RAO				APPROVED S.G			APPROVED S.G
DRG.REDRAWN IN AUTOCAD.				ø2774 WAS ø2770. ø2964 WAS ø2960			ø2788 WAS ø2774.		

COMPUTER NO. 46100147 THE INFORMATION ON THIS DOCUMENT IS THE PROPERTY OF BHARAT HEAVY ELECTRICALS LIMITED. IT MUST NOT BE USED DIRECTLY OR INDIRECTLY IN ANY WAY DETRIMENTAL TO THE INTEREST OF THE COMPANY.

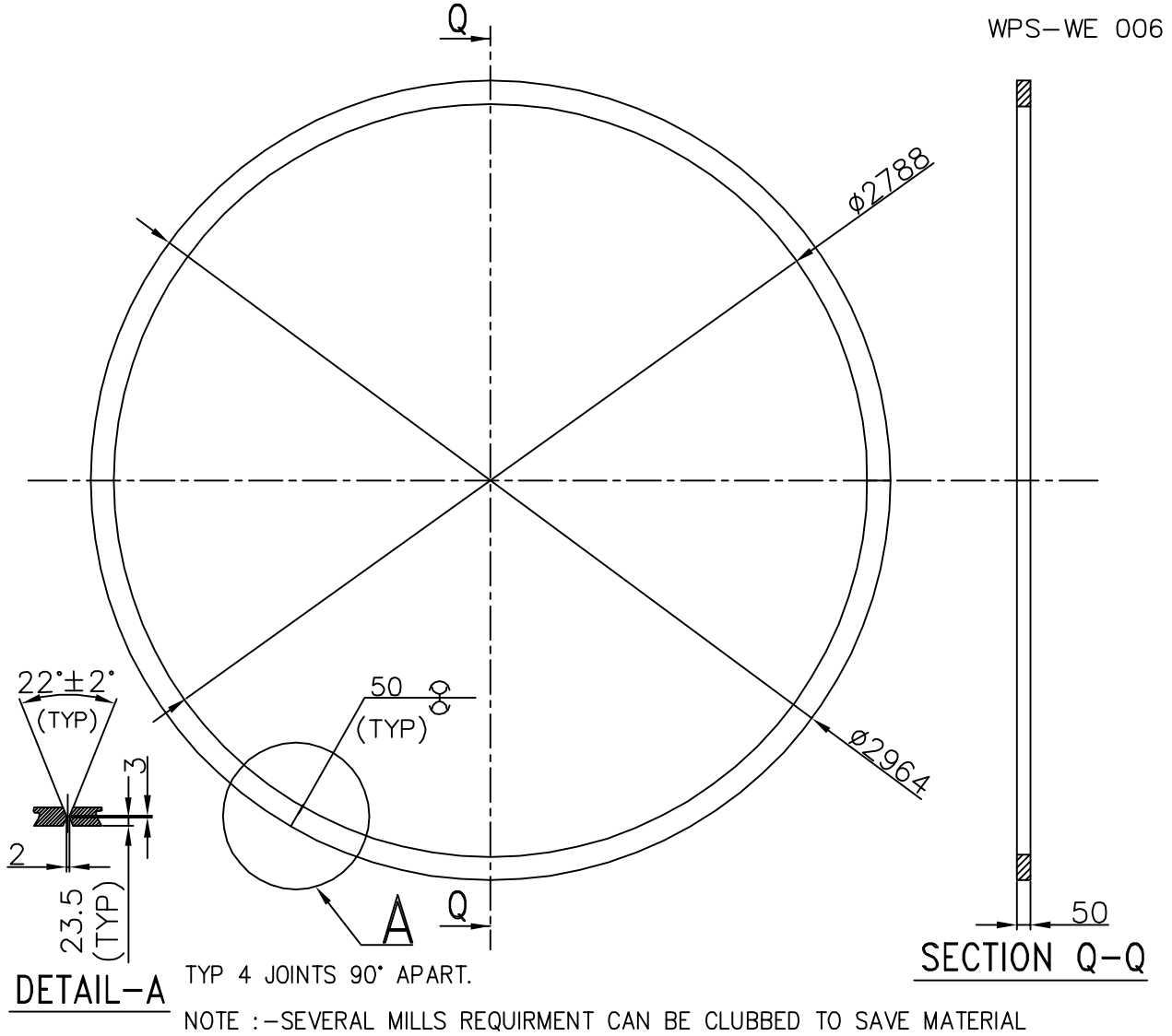

DETAIL-A

TYP 4 JOINTS 90° APART.

NOTE :--SEVERAL MILLS REQUIRMENT CAN BE CLUBBED TO SAVE MATERIAL

PLATE		50 X 880 X 2100 FOR 4 SEGMENTS	HY1018819886	312	725.0
			AA101019	1	
DESCRIPTION & DRG.NO.	VAR NO.	RAW MATERIAL SIZE OR CASTING DRG.NO. OR FORGING DRG.NO.	MATL. CODE	NET.WT.	GROSS WT
			MATL. SPECN.	QTY.	

TYPE OF PRODUCT OR NAME OF CUSTOMER/PROJECT

REF. TO HY0230261 FOR UNSPECIFIED TOLERANCES.	BHARAT HEAVY ELECTRICALS LTD. HYDERABAD	DRN.	E.M.ASHOK	19-06-01	NO.OF VAR.	
		CKD.	AMAN SURIN	19-06-01		
		APPD.	S.GHATGE	19-06-01		NA
	DEPT.	PULVE ENGG	SCALE	WEIGHT(K.G.)	REF.TO ASSY.DRG.	ITEM NO.
CODE	446	1:25	312.0	NA	NA	NA
TITLE				DRAWING NO.		REV.
FLANGE				4-61-376-00147		05
			SHT.NO.	01	NO.OF SHT.	01

COMPUTER NO. 46100148
 REF. DRG. NO.
 SIGN. & DATE
 INVENTORY NO.

THE INFORMATION ON THIS DOCUMENT IS THE PROPERTY OF BHARAT HEAVY ELECTRICALS LIMITED. IT MUST NOT BE USED DIRECTLY OR INDIRECTLY IN ANY WAY DETRIMENTAL TO THE INTEREST OF THE COMPANY.

REV 04	DATE 10-6-01	ALTERED CHECKED S.S APPROVED K.M.RAO	E.M.ASHOK	REV 05	DATE 8.12.04	ALTERED CHECKED AMAN APPROVED S.GHATGE	REV 06	DATE 12.05.06	ALTERED CHECKED AMAN APPROVED S.GHATGE	
DRG. RETRACED				Ø2768 WAS 2718.				Ø2782 WAS Ø2768. PL THK WAS 25. MAT CODE WAS AA1011819155.		

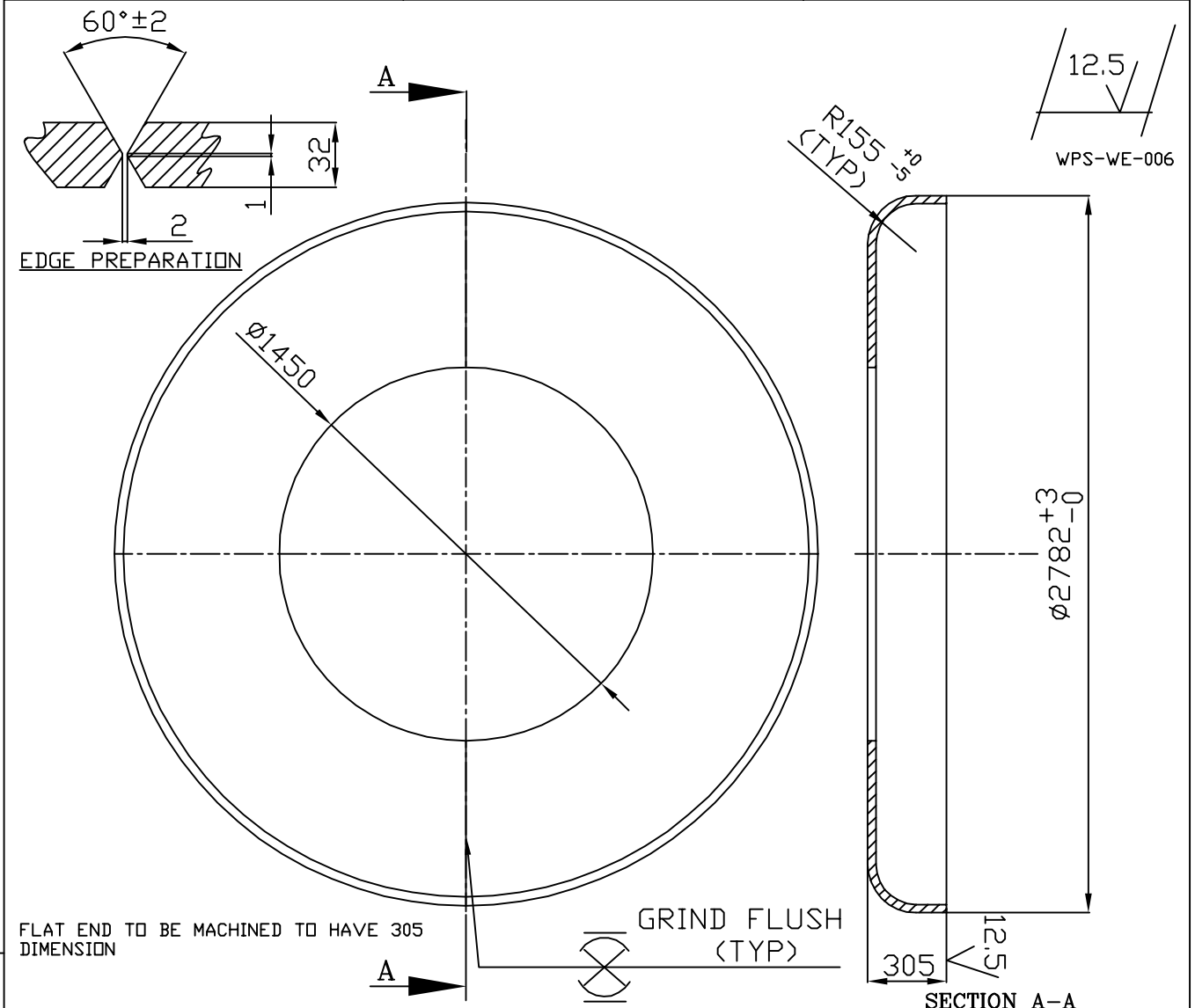

PLATE		32X3300X3300	HY1018819932	1566	2735
			AA10119	1	
DESCRIPTION & DRG.NO.	VAR NO.	RAW MATERIAL SIZE OR CASTING DRG.NO. OR FORGING DRG.NO.	MATL. CODE	NET.WT.	GROSS WT
			MATL. SPECN.	QTY.	

TYPE OF PRODUCT OR NAME OF CUSTOMER/PROJECT

REF. TO HY0230261 FOR UNSPECIFIED TOLERANCES.	BHARAT HEAVY ELECTRICALS LTD. HYDERABAD	DRN.	E.M.ASHOK	SIGN	<i>[Signature]</i>	DATE	7-3-2001	NO. OF VAR.	
		CKD.	S.G	SIGN	<i>[Signature]</i>	DATE	7-3-2001		
		APPD.	K.M.R	SIGN	<i>[Signature]</i>	DATE	7-3-2001		
DEPT. PULV.ENGG		SCALE	1:25	WEIGHT(K.G.)	1566.0	REF.TO ASSY.DRG.	NA	ITEM NO.	NO. OF ITEM
CODE 446									
TITLE						DRAWING NO.		REV.	
PRESSING						4-61-376-00148		06	
						SHT.NO.	01	NO. OF SHT.	01



ACCEPTANCE STANDARDS FOR LIQUID PENETRANT EXAMINATION OF WELDS

1.0 SCOPE:

- 1.1 This standard covers the "Acceptance Standards For Liquid Penetrant Examination Of Welds' .
- 1.2 The procedure for liquid penetrant examination shall be as per Corporate Standard AA 085 01 31: Procedure For Liquid Penetrant Examination.
- 1.3 This standard is based on ASME Section 8, Division 1, Appendix 8.

2. DEFINITION OF INDICATIONS:

Relevant indications are those which result from mechanical discontinuities. Indications with major dimensions greater than 1.6 mm only shall be considered relevant.

- 2.1 Linear indications are those indications in which the length is more than three times the width.
- 2.2 Rounded indications are those indications which are circular or elliptical with the length equal to or less than 3 times the width.
- 2.3 Any questionable or doubtful indications shall be retested to verify whether or not they are relevant.
- 2.4 Localised surface imperfections, such as may occur from machining marks, surface conditions or incomplete bond between base metal and cladding may produce similar indications which are not relevant to the detection of unacceptable discontinuities.

3. ACCEPTANCE STANDARDS:

All surfaces to be examined shall be free from:

- a) relevant linear indications.
- b) relevant rounded indications greater than 4.8 mm.
- c) four or more rounded defects in line separated by 1.6 mm or less (edge to edge) except where the specification for the material establishes different requirements for acceptance so far as defects are concerned.

Revisions:

APPROVED:

**INTERPLANT
STANDARISATION COMMITTEE WG - NDT**

Rev. No.

Rev. Date

Revised:

Prepared
HYDERABAD

Issued
Corp. R&D

Date:
SEP. '87



CORPORATE STANDARD

AA 085 01 31

PAGE 1 OF 8

PROCEDURE FOR LIQUID PENETRANT EXAMINATION

1.0 SCOPE:

1.1 This standard details the procedure for liquid penetrant examination of non-porous ferrous and non-ferrous and non-metallic materials such as ceramics, plastics, glass, etc.

1.2 Typical surface discontinuities detectable by this method are cracks, seams, laps, cold shuts, porosity, laminations, etc.

1.3 This standard conforms substantially with ASTM E 165 — 1980 — (Reapproved 1989) and ASME code section V, Article 6.

2.0 PERSONNEL REQUIREMENT:

Personnel performing non-destructive examination and evaluation shall be qualified to the recommended practice SNT-TC-1A or any other recognised practice.

3.0 DESCRIPTION:

In principle a liquid penetrant is applied to the surface to be examined and allowed to enter discontinuities, excess penetrant removed, the part dried and a developer applied. The developer functions both as a blotter to absorb penetrant that has been trapped in discontinuities and as a contrasting back ground to enhance the visibility of penetrant indications.

4.0 APPROVED METHODS & MATERIALS:

4.1 Either a colour contrast or fluorescent penetrant method may be used. Any one of the following penetrants shall be used:

- (a) Solvent Removable
- (b) Post Emulsifying
- (c) Water Washable

4.2 For nickel base alloys and/or for stainless steel materials used in nuclear components the penetrant materials, cleaner, penetrant developer, etc., used shall not contain sulphur or halogen above 1% by weight.

4.3 Selection of liquid penetrant material shall be from the same family (brand). Inter-mixing of family of liquid penetrant materials is not allowed.

5.0 PROCEDURE:

5.1 Surface Preparation:

COPYRIGHT AND CONFIDENTIAL
The information on this document is the property of BHARAT HEAVY ELECTRICALS LIMITED. It must not be used directly or indirectly in any way detrimental to the interest of the company.

Revisions:

Cl.7.10 of MOM of WG(NDT)

INTERPLANT
STANDARDIZATION COMMITTEE - WG
(NDT)

Rev. No. 02

Amd. No. 01

Reaffirmed

Prepared

Issued

Date

DT. NOV. '92

DT. 19.3.94

year. 1998

CORP. R&D

CORP. R&D

SEP. '79

CS-757



- 5.1.1 Surface preparation by grinding or machining or other method may be employed where surface irregularities may mask indications of unacceptable discontinuities.
- 5.1.2 The surface to be examined and all adjacent areas within at least 25 mm shall be dry and free from any dirt, lint, scale, rust, welding flux, weld spatter, grease, oil or other extraneous matter that could obscure surface openings or otherwise interfere with examination.
- 5.1.3 The surface to be examined shall be cleaned with detergents, organic solvents, descaling solutions or paint removers. Degreasing and ultrasonic cleaning may be employed to increase cleaning efficiency. Cleaning method employed is an important part of the examination procedure. Cleaning solvents shall meet the requirements of C1.4.2.

Caution: Blasting with shot or dull sand, rotofinishing, buffing, wire brushing the soft material or machining with dull tools shall not be used as they maypeen the discontinuities at the surface.

5.2 Drying:

Drying, after cleaning the surface to be examined, shall be accomplished by normal evaporation or with forced hot air, as appropriate. A minimum period of time shall be established to ensure that the cleaning solution has evaporated prior to application of the penetrant.

5.3 Application Of Penetrants:

- 5.3.1 The penetrant shall be applied by dipping, brushing or spraying. If the penetrant is applied by spraying using compressed air type apparatus, filters shall be placed at the air inlet to preclude contamination of penetrant by oil, water or dirt sediment that may have collected in the lines. Spraying should only be performed in a booth equipped with exhaust system.
- 5.3.2 The length of penetration time is critical and depends upon the material being inspected, the process through which it has passed and the type of discontinuities expected. The recommended penetration time is given in Table 1.
- 5.3.3 The temperature of the penetrant and the surface of the part to be examined shall not be below 10°C(50°F) nor above 50°C(125°F) throughout the examination period. Local heating or cooling is permitted provided the temperatures remain in the range of 10 to 50°C during the examination. Where it is not practical to comply with these temperature limitations, other temperatures and times shall be used provided the procedures are qualified as described in Annexure-I.

5.4 Removal Of Excess Penetrant:

After the penetration time specified in the procedure has elapsed, any penetrant remaining on the surface shall be removed, taking care to minimise removal of penetrant from discontinuities.



5.4.1 Postemulsifying Penetrants:

The emulsifier shall be applied by spraying or dipping. The emulsifying time shall not exceed 5 minutes. After emulsification, the mixture shall be removed by water spray.

5.4.2 Solvent Removable Penetrants:

Excess penetrant shall be removed by wiping with a cloth or absorbent paper repeating the operation until most traces of penetrants have been removed. The remaining traces shall be removed by wiping the surface lightly with cloth or absorbent paper moistened with solvent.

Caution: Care shall be taken to avoid excess solvent as this may remove penetrants from discontinuities. Flushing the surface with solvent following the application of the penetrant and prior to developing is prohibited.

5.4.3 Water Washable Penetrants:

Excess water washable penetrant shall be removed with a water spray. The water pressure shall not exceed 0.35 N/mm² (50 Psi) and the water temperature shall not exceed 43.3°C (110°F).

5.5 Drying:

Surface shall be dried before the application of developer.

- 5.5.1 a) If postemulsifying or water washable method is used, the surface shall be dried by blotting with clean materials or by using circulating warm air, provided the temperature of the surface is not raised above 50°C (125°F).
- b) For solvent removable method, the surface may be dried by normal evaporation, blotting, wiping or forced air.

5.6 Application Of Developer:

The developer shall be applied as soon as possible after the removal of the excess penetrant. Two types of developer, dry or wet, shall be used with fluorescent penetrant. With colour contrast penetrants, only wet developer shall be used.

5.6.1 Application Of Dry Developer:

Dry developer shall be applied by a soft brush, a hand operated powder bulb or a powder gun or other means provided the powder is dusted evenly over the entire surface being examined.

5.6.2 Application Of Wet Developer

Prior to applying suspension type wet developer to the surface, the developer must be thoroughly agitated to ensure adequate dispersion of suspended particles.

(a) Aqueous Developer Application:

Aqueous developer may be applied to either a wet or dry surface. It shall be applied by dipping, spraying or other means provided a thin coating is obtained over the entire surface being examined. Drying time may be decreased by using warm air, provided the surface temperature of the part is not raised above 50°C.

(b) Non-aqueous Developer Application:

Non-aqueous developer shall be applied only on a dry surface. It shall be applied by spraying, except where safety or restricted access preclude it. Under such conditions developer may be applied by brushing. Drying shall be by normal evaporation.

6.0 EXAMINATION:

Observe the surface during the application of the developer to detect nature of any indications which tend to bleed out profusely. Final examination shall be done between 7 minutes at the earliest and 30 minutes at the latest after application of the developer. The nature of discontinuities corresponding to the indications shall be defined depending upon the method of setting, appearance, direction, shape and dimensions of the same. If the bleed out does not alter the examination results, longer periods are permitted. If the surface to be examined is large enough to preclude complete examination within the prescribed time the surface shall be examined in increments.

6.1 Colour Contrast Penetrants (Visible Dye Penetrants):

6.1.1 With colour contrast penetrants the developer forms a reasonably uniform coating. Surface discontinuities are indicated by bleeding out of the penetrant which is normally of a deep red colour. Indication with a light pink colour may indicate excessive cleaning. Inadequate cleaning may leave an excessive background making interpretation difficult.

6.1.2 Adequate illumination is required to ensure no loss of the sensitivity in the examination. Examination shall be done under natural or suitable light (illumination level shall be in the order of 500 LUX).

6.2 Fluorescent Penetrants:

Examination of the surface shall be carried out with a high intensity black light in a darkened area or booth. Black light shall have a wave length of 3650 Å°. The bulbs shall be allowed to warm up for not less than 5 minutes prior to use in the examination. The black light intensity shall be at least of 800 uW/cm² on the surface of the part being examined and the light source being kept at a distance of at least 375 mm from the surface being examined. The operator should allow his eyes to become accustomed to the darkness of the inspection booth for at least 5 minutes before inspecting the parts. He should avoid looking directly into the black light and also avoid going from the darkness to



the light and back again **without allowing** sufficient time for his eyes to adjust to the darkness. The intensity shall be measured at least once every 8 hours and whenever the work station is changed.

7.0 EVALUATION OF INDICATIONS & INTERPRETATION:

- 7.1 As the developer dries to a smooth, even white coating, indications will appear at the locations of discontinuities. Depth of surface discontinuities may be correlated with the richness of colour and speed of bleeding out. However, localised surface imperfections such as may occur from machining marks or surface conditions may produce similar indications which are non-relevant.
- 7.2 Usually, a crack or similar opening will show a line and light cracks or partially welded lap will show a broken line. Gross porosity may produce large indications covering an entire area. Very fine porosity is indicated by random dots.
- 7.3 Any non-relevant indication shall be regarded as a defect until the indication is either eliminated by surface conditioning or it is Proved non-relevant by other NDT methods.
- 7.4 Linear indications are those indications in which the length is more than three times the width. Rounded indications are indications which are circular or elliptical with the length less than three times the width.
- 7.5 All indications shall be evaluated in terms of the acceptance standards of the referencing documents.

8.0 ACCEPTANCE STANDARDS:

- 8.1 For castings - Refer Corporate Standard AA 085 01 32.
- 8.2 For Austenitic Forgings - Refer Corporate Standard AA 085 01 30.
- 8.3 For Welds - Refer Corporate Standard AA 085 01 29.

9.0 POST EXAMINATION CLEANING:

Surfaces examined shall be cleaned after evaluation of the test with dry cotton rag with or without water rinse.

TABLE - 1 (Clause 5.3.2)

Suggested Penetration Time For Post-emulsified And Solvent
Removable Penetrants

Material	Form	Type of discontinuity	*Penetration time (min.)
Aluminium	Castings	Porosity	5
		Cold shut	5
	Extrusions & Forgings	Laps	10
		Lack of fusion	5
	Welds	Porosity	5
	All forms	Cracks	10



TABLE - 1 (Clause 5.3.2) Contd.

Material	Form	Type of discontinuity	*Penetration time (min.)
Magnesium	Castings	Porosity	5
		Cold shut	5
	Extrusions & Forgings	Laps	10
		Lack of fusion	10
		Welds	10
All forms	Cracks	10	
Steel	Castings	Porosity	10
		Cold shut	10
	Extrusions & Forgings	Laps	10
		Lack of fusion	20
		Welds	20
All forms	Cracks	20	
Brass & Bronze	Castings	Porosity	5
		Cold shut	5
	Extrusions & Forgings	Laps	10
		Lack of fusion	10
		Brazed parts	Porosity
All forms	Cracks	10	
Plastics	All forms	Cracks	5
Glass	All forms	Cracks	5
Carbide tipped tools	All forms	Lack of fusion	5
		Porosity	5
		Crack	20
Titanium & high temperature alloys	All forms		20 to 30
Ceramic	All forms	Cracks	5
		Porosity	5

* For lower temperatures, penetration time should be increased.

ANNEXURE - 1 (Clause 5.3.3)

PROCEDURE FOR NON-STANDARD TEMPERATURES

A.1 General:

When it is not practical to conduct a liquid penetrant examination within the temperature range of 15.6 to 51.6°C (60 to 125°F), the examination procedure at the proposed lower or higher temperature range requires qualification. This shall require the use of a quenched cracked aluminium block, which is designated as 'Liquid Penetrant Comparator Block'.

COPYRIGHT AND CONFIDENTIAL
The information on this document is the property of BHARAT HEAVY ELECTRICALS LIMITED.
It is not to be used directly or indirectly in any way detrimental to the interest of the company.

CS - 757



A.2 Liquid Penetrant Comparator Block:

The liquid penetrant comparator block shall be **made of aluminum**, ASTM B209, Type 2024 or SB-211. Type 2024, 10 mm (3/8 in.) thick, and shall have approximate face dimensions of 50 mm x 75 mm (2 in. x 3 in.). At the centre of each face, an area approximately 25 mm in diameter shall be marked with a 510°C (950°F) temperature indicating crayon or paint. The marked area shall be heated with a blow torch, a Bunsen burner or similar device to a temperature between 510°C (950°F) and 524°C (975°F). The specimen shall then be immediately quenched in cold water which produces a network of the fine cracks on each face. The block shall then be dried by heating to approximately 149°C (300°F). After cooling, the block shall be cut into two halves. One half of the specimen shall be designated block 'A' and the other block 'B' for identification in subsequent processing. Figure 1 illustrates the comparator blocks "A" and "B". As an alternate to cutting the block in half to make blocks "A" and "B", separate blocks 50 mm x 75 mm (2 in. x 3 in.) can be made using the heating and quenching technique as described above. Two comparator blocks with closely matched crack patterns may be used. The blocks shall be marked "A" and "B".

A.3 Comparator Application:

- (a) If it is desired to qualify a liquid penetrant examination procedure at a temperature of less than 15.6°C (60°F) the proposed procedure shall be applied to block "B" after the block and all materials have been cooled and held at the proposed examination temperature until the comparison is completed. A standard procedure which has previously been demonstrated as suitable for use shall be applied to block "A" in the 15.6 to 51.6°C (60 to 125°F) temperature range. The indications of cracks shall be compared between blocks "A" and "B". If the indications obtained under the proposed condition on block "B" are essentially the same as obtained on block "A" during examination at 15.6 to 51.6°C (60 to 125°F), the proposed procedure shall be considered qualified for use.
- (b) If the proposed temperature for the examination is above 51.6°C (125°F), block "B" shall be held at this temperature throughout the examination. The indication of cracks shall be compared as described in T-647.3(a) while block "B" is at the proposed temperature and block "A" is at the 15.6 to 51.6°C (60 to 125°F) temperature range.
- (c) A procedure qualified at a temperature lower than 15.6°C (60°F) shall be qualified from that temperature to 15.6°C (60°F).
- (d) To qualify a Procedure for temperatures above 51.6°C (125°F), the upper and lower temperature limits shall be established and the procedure qualified at these temperatures.
- (e) As an alternate to the requirements of (a) and (b) when using color contrast penetrants, it is permissible to use a single comparator block for the standard and non-standard temperatures and to make the comparison by photography.



- (f) When the single comparator block and photographic technique is used, the processing details (as applicable) described in (a) and (b) above shall apply. The block shall be thoroughly cleaned between the two processing steps. Photographs shall be taken after processing at the nonstandard temperature and then after processing at the standard temperature. The indication of cracks shall be compared between the two photographs. The same criteria for qualification as (a) above shall apply.
- (g) Identical photographic techniques shall be used to make the comparison photographs.

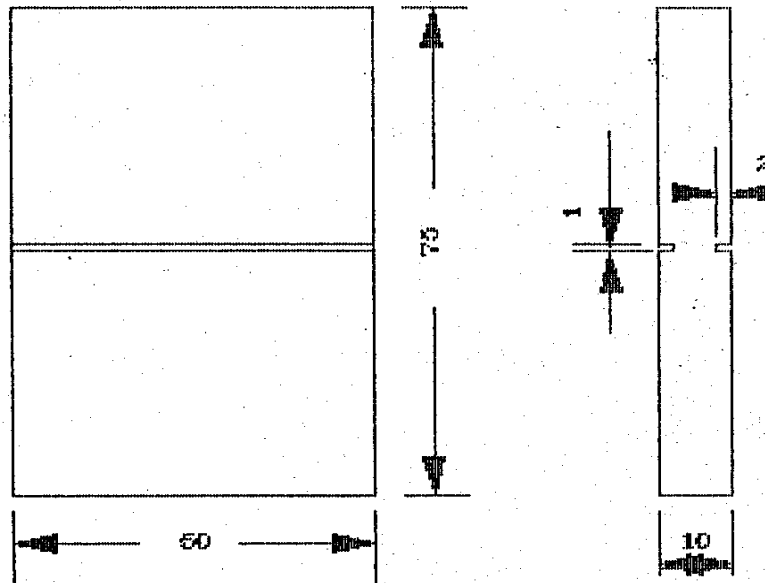

FIGURE: 1-LIQUID PENETRANT COMPARATOR BLOCK

COPYRIGHT AND CONFIDENTIAL
The information on this document is the property of BHARAT HEAVY ELECTRICALS LIMITED.
It must not be used directly or indirectly in any way detrimental to the interest of the company.



CORPORATE PURCHASING SPECIFICATION

AA10119

Rev No. 15

PAGE 1 of 2

STRUCTURAL STEEL - WELDABLE QUALITY (PLATES, SECTIONS, STRIPS, FLATS AND BARS)

ORDERING DESCRIPTION

1.0 GENERAL:

The material shall conform to IS 2062 – 2011, E250-Gr.BR (with mandatory Impact Test) or DIN EN 10025-2:2005, Gr. S275JR and comply with following additional requirements.

2.0 APPLICATION:

For general engineering purposes, suitable for welding.

3.0 CONDITION OF DELIVERY:

3.1 Bars & Sections shall be supplied in Hot rolled in straight lengths without twists and bends.

3.2 The material shall be supplied as per IS: 2062 – 2011, E250 Gr.BR (with mandatory Impact Test) or as per DIN EN 10025-2:2005 Gr. 275JR.

3.3 Any other additional requirement as per BHEL Purchase order.

4.0 DIMENSIONS AND TOLERANCES:

4.1 Sizes:

Material shall be supplied to the dimensions specified in BHEL Order.

4.2 Tolerances:

The tolerances on hot rolled material shall comply with IS: 1852 or any other equivalent national standard.

4.3 Straightness for hot rolled bars:

Unless otherwise specified, the permissible deviation in straightness shall not exceed 5 mm in any 1000 mm length.

5.0 TEST SAMPLES:

The selection of test pieces for all tests like Chemical, Mechanical etc. shall be as per IS: 2062, E250-Gr.BR or DIN EN 10025-2, Gr. S275JR.

Revisions:
Clause No. 1, 3, 5 & 8 revised (as per MOM of 38th MRC meeting), Clause 10 added

APPROVED:
INTERPLANT MATERIAL RATIONALISATION COMMITTEE – MRC(S&GPS)

Rev No.15	Amd No.	Reaffirmed	Prepared	Issued	Dt. of 1 st Issue
Dt:11-03-2014	Dt:	Year:	HPEP, Hyderabad	Corp.R&D	June, 1976

COPYRIGHT AND CONFIDENTIAL
The Information on this document is the property of BHARAT HEAVY ELECTRICALS LIMITED.
It must not be used directly or indirectly in any way detrimental to the Interest of the company.

26/6/14

CS-72

CORPORATE PURCHASING SPECIFICATION



6.0 ULTRASONIC EXAMINATION:

Plates shall be ultrasonically examined in accordance with BHEL standard AA0850120 (or ASTM-A435) as detailed below and shall comply with the acceptance standards specified therein.

6.1 For plates above 40 mm thick:

Shall be ultrasonically examined unless when otherwise specified in order.

7.0 TEST CERTIFICATES:

Unless otherwise specified, three copies of test certificates shall be supplied.

In addition, the supplier shall ensure to enclose one copy of the test certificate along with their dispatch documents to facilitate quick clearance of the material.

The test certificate shall bear the following information:

AA10119 - Rev.No.15/ IS: 2062-Gr: BR (with mandatory Impact test) or DIN EN 10025-2, Gr. S275JR,

BHEL order No.

Melt No, Size & Quantity, Batch No with heat treatment details, Results of Chemical analysis,

Mechanical tests & NDT, Supplier's name, Identification No, TC No, Signature of Competent Authority, etc.

8.0 PACKING AND MARKING:

Plates shall be transported suitably to avoid damage during transit.

Each plate shall be marked with Melt No. Material grade and specification, BHEL Order No, Supplier's Name Identification No, Size & weight, on any one corner and encircled with paint preferably of white colour.

9.0 REJECTION AND REPLACEMENT

If the material does not comply with the requirements of this specification during receipt inspection at BHEL or if any defect is found during further processing of material, BHEL reserves the right to reject the whole consignment and the supplier shall replace the material free of cost. The rejected material shall be taken back by the supplier after fulfilling the commercial terms and conditions.

10.0 REFERRED STANDARDS (Latest publications including amendments):

1) IS: 1852

2) ASTM - A435

3) AA0850120

26/6/14

CS-721

**CORPORATE PURCHASE SPECIFICATION**

AA 551 54

Rev. No. 03

PAGE 1 OF 2

RUST PREVENTIVE HARD FILM, BLACK (TRP)**1.0 GENERAL:**

This specification governs the quality requirements of temporary rust preventive (TRP), coating a hard film on drying. The material consists of film forming ingredients dissolved in solvents to give a low viscous liquid at room temperature. On evaluation of solvents, a thin though abrasion resistant film capable of being handled without damage shall be obtained. Normally this material gives protection upto six months and thereafter requires inspection and reapplication, if necessary.

2.0 APPLICATION:

Depending upon components and their sizes, the rust preventive can be applied by brush, dip or spray. Two liberal coats are desirable for adequate protection. The surface to be coated with anti rust solution should be absolutely clean and free from rust.

3.0 REMOVAL:

This TRP can be removed by cotton cloth soaked in white spirit to BHEL specification AA 56701.

4.0 COLOUR : Steel Black.**5.0 COMPLIANCE WITH NATIONAL STANDARDS:**

The material shall comply with the requirements of the following national standards and also meet the requirements of this specification.

IS: 1153 - 2000:RA-2005 Temporary Corrosion Preventive, Fluid, Hard Film, Solvent deposited,

6.0 COMPOSITION:

The composition shall be based on asphalt, mineral oil and inhibitive pigments with suitable additives.

7.0 TEST SAMPLES:

Half a litre of sample shall be taken for testing and approval.

8.0 PROPERTIES:

When tested in accordance with the relevant clauses of BHEL standard AA 085 00 01, the test sample shall show the following properties:

8.1 Consistency : 90 ± 10 seconds in Ford Cup No.4 at 27± 0.5°C.

8.2 Drying Time : Tack free: Within one hour
Hard dry : 16 hours

8.3 Flash Point : 32°C, min.

Revisions:

As per 40th MOM of MRC-CPO

APPROVED:

INTERPLANT MATERIAL
RATIONALISATION COMMITTEE-MRC (CPO)

Rev. No. 03

Amd.No.

Reaffirmed

Prepared
BHOPALIssued
Corp. R&DDt. of 1st Issue
NOVEMBER, 1982

Dt. 26.05.2012

Dt:

Year:



8.4 Weight : 11 ± 0.5 kg per 10 litres.

8.5 Non-volatile Matter : 58 ± 2% by mass.

8.6 Test for Adhesion : To pass the test

8.7 Spreading Capacity : 8.0 sq.meter/litre, minimum

8.8 Protection against corrosion at high temperature and humidity:

To pass the test for 360 hours, minimum..

9.0 TYPE TESTS:

Whenever specified, the following tests shall be carried out, as per the methods mentioned against each:

i) **Protection against corrosion under conditions of condensation (IS:101, part 6/sec.1):**

No sign of corrosion on the surface after 21 days of exposure.

10.0 TEST CERTIFICATES:

Three copies of test certificates shall be supplied alongwith each consignment, giving the following information:

In addition, the supplier shall ensure to enclose one copy of the test certificate alongwith the despatch documents to facilitate quick clearance of the material.

AA 551 54, Rev. 03 : Rust preventive hard film, black (TRP)

BHEL Order No.

Batch / Lot No.

Supplier's/ Manufacturer's Name and Trade mark, if any

Date of manufacture and expiry

Test results of clause 8.0 & 9.0.

11.0 KEEPING PROPERTY:

When stored in a covered dry place in the original sealed containers under normal temperature conditions, the material shall retain the properties prescribed in this specification for a period of not less than 12 months after the date of manufacture which shall be subsequent to the date of placing the order.

12.0 PACKING & MARKING:

Unless otherwise specified, the material shall be supplied in 4 kg steel containers, which shall be leak free, dry and clean.

Each container shall marked with the following information:

AA 551 54: Rust preventive hard film, black (TRP)

BHEL Order No.

Supplier's / Manufacturer's Name and Trade mark, if any

Batch No./Lot No.

Date of manufacture and expiry

Quantity supplied

8.0 ENVIRONMENTAL REQUIREMENTS:

The supplier shall furnish Material Safety Data Sheet (**MSDS**) covering all information relating to human safety and environmental impacts of the hazardous materials particularly during their transportation, storage, handling and disposal alongwith each supply.

Each container shall be marked with corresponding symbol and minimum worded cautionary notice for flammable / corrosive / toxic / harmful / irritant and oxidizing etc. as applicable

13.0 REFERRED STANDARDS (Latest Publications Including Amendments):

1. AA 085 00 01

2. AA 56701

3. IS: 1153



CORPORATE PURCHASE SPECIFICATION

AA 551 55

Rev. No. 02

PAGE 1 OF 3

RUST PREVENTIVE, DRYING TYPE – PIGMENTED (TRP)

1.0 GENERAL:

This specification governs the quality of pigmented drying temporary hard film TRP coating. The material consists of a film forming synthetic resin, inhibition pigment (zinc chromate/ zinc phosphate) and suitable additives. This bright yellow pigmented preservative gives long term preservation at medium and high ambient upto one year and needs inspection and reapplication, if necessary.

2.0 APPLICATION:

Depending upon the components and their size, the rust preventive can be applied by brush, spray or dip. Two liberal coats are desirable for adequate protection. The surface to be coated with rust solution should be scrupulously clean and devoid of rust.

3.0 COLOUR:

Yellow.

4.0 COMPLIANCE WITH NATIONAL STANDARDS:

There is no Indian standard covering this material.

5.0 CHEMICAL COMPOSITION:

The composition shall be based on synthetic resin inhibitive pigment (zinc chromate/zinc phosphate) with suitable additives.

6.0 TEST SAMPLES:

Half a litre of sample shall be taken from each consignment for testing and approval.

6.1 To draw a representative sample, the contents of the container selected for sampling shall be mixed as thoroughly as possible by shaking or stirring or both or by rolling, so as to bring all portions into uniform distribution.

6.2 The samples shall be taken in a suitable, clean, dry air-tight glass bottle of one liter capacity. It should be almost but not completely filled by the sample.

6.3 In case of failure of first sample, two samples shall be drawn from other two drums of the same consignment at random and failure of the second sample in complying with the specification will lead to the rejection of the whole consignment.

7.0 PROPERTIES:

When tested in accordance with test methods mentioned against each, the test sample shall show the following properties:

7.1 Consistency (AA 085 00 01):

60 – 70 seconds in cup No. 4 to IS: 3944 -1982, RA-2005at 27± 0.5° C.

7.2 Drying Time (AA 085 00 01):

Touch dry : within one hour

Hard dry : 16 hours

Revisions:

As per 40th MOM of MRC-CPO

APPROVED:

INTERPLANT MATERIAL
RATIONALISATION COMMITTEE-MRC (CPO)

Rev. No. 02

Amd.No.

Reaffirmed

Prepared

Issued

Dt. of 1st Issue

Dt. 26.05.2012

Dt :

Year:

BHOPAL

Corp. R&D

JANUARY, 1990

**7.3 Weight in kg per 10 litres (AA 085 00 01):**

14.0 ± 0.5

7.4 Non-volatile Content (AA 085 00 01):

73 ± 2% by mass.

7.5 Test for Adhesion (AA 085 00 01):

To pass the test.

7.6 Protection Against Corrosion at High Temperature and Humidity (AA 085 00 01):

No sign of corrosion under the film.

7.7 Scratch Hardness (IS: 1153):

To pass the test.

8.0 REMOVAL:

This shall be removable by using white spirit to BHEL specification AA 567 01.

9.0 TYPE TESTS:**9.1 Flash Point (AA 085 00 01):**Above 35⁰ C.**9.2 Spreading capacity (AA 085 00 01):**

6.5 sq.m per litre. minimum.

9.3 Salt spray Test for 7 days (IS:2074):

No sign of corrosion underneath the paint film.

10.0 TEST CERTIFICATES

Three copies of test certificates shall be supplied alongwith each consignment, giving the following information:

In addition, the supplier shall ensure to enclose one copy of the test certificate alongwith the despatch documents to facilitate quick clearance of the material.

AA 5551 55, Rev. 02 : Rust preventive, drying type-pigmented (TRP)

BHEL Order No.

Batch / Lot No.

Supplier's/ Manufacturer's Name and Trade mark, if any

Date of manufacture and expiry

Test results of clause 7.0.



CORPORATE PURCHASE SPECIFICATION

AA 551 55

Rev. No. 02

PAGE 3 OF 3

11.0 KEEPING PROPERTY:

When stored in a covered dry place in the original sealed containers under normal temperature conditions, the material shall retain the properties prescribed in this specification for a period of not less than 12 months after the date of manufacture which shall be subsequent to the date of placing the order.

12.0 PACKING & MARKING

Unless otherwise stated, the TRP shall be supplied in 4 kg steel containers.

Each container shall bear the following information:

AA 551 55: Rust preventive, drying type-pigmented (TRP)

BHEL Order NO.

Supplier's / Manufacturer's Name

Trade mark, if any

Date of manufacture and expiry

Batch No.

Quantity supplied

13.0 ENVIRONMENTAL REQUIREMENTS:

The supplier shall furnish Material Safety Data Sheet (**MSDS**) covering all information relating to human safety and environmental impacts of the hazardous materials particularly during their transportation, storage, handling and disposal alongwith each supply.

Each container shall be marked with corresponding symbol and minimum worded cautionary notice for flammable / corrosive / toxic / harmful / irritant and oxidizing etc. as applicable

14.0 REFERRED STANDARDS (Latest Publications Including Amendments)

1. AA 085 00 01

2. AA 567 01

3. IS: 1153

4. IS 2074

5. IS 3944



CORPORATE PURCHASING SPECIFICATIONS

AA56101

Rev. No.07

PAGE 1 of 5

ANTI-CORROSIVE PRIMING PAINT

1.0 GENERAL:

This specification governs the quality requirements of air drying Anti Corrosive ready mixed Red oxide Zinc phosphate priming paint which shall be capable of being brushed, sprayed by conventional methods. The priming paint shall be suitable to be thinned with MTO/white spirit conforming to BHEL specification AA56701.

The paint shall be compatible with high quality full glossy outdoor finishing paint to BHEL specification AA56126 (IS: 2932), when surfaces primed with this paint are coated with 2 coats of finishing paint.

2.0 APPLICATION:

The material shall be intended for use as a primer coat in the painting system for protection of steel surfaces against corrosion for outdoor and indoor application on Electrical equipment. Normally, for best performance the surface to be coated shall be ensured free from oil, loose rust/dust etc., followed by blast cleaning to Sa 2 1/2.

This shall be followed by application of two coats of the priming so as to achieve dft of 30 microns, min.

3.0 COMPLIANCE WITH NATIONAL STANDARDS:

The material shall comply with the requirements of the following national standard and also meet the requirements of this specification.

IS: 12744 - 1989 (Reaffirmed 2004): Ready Mixed Paint, Air Drying, Red Oxide-Zinc Phosphate Priming-Specification.

4.0 COLOUR: The colour of the material shall be that of red oxide.

5.0 FINISH: Smooth and Matt to Egg shell flat

6.0 FREEDOM FROM DEFECTS:

The priming paint shall remain free from defects like hard settling of pigments, thick and hard skinning etc., when kept in closed container and livering (excessive viscosity build up) during its rated shelf life.

The dried surface of the coating shall be smooth, uniform, homogenous appearance and shall be free from physical defects like, pinholes, wrinkles, hard particles, blisters, air bubbles etc.

7.0 CHEMICAL COMPOSITION:

The paint shall be formulated with anti-corrosive pigments like Red oxide of iron, Zinc phosphate, extenders etc., dispersed in unsaponifiable modified alkyd medium in solvent, thinner and drier in suitable proportions so as to satisfy the requirements prescribed in this

Revisions:
As per 40th MOM of MRC-CPO

APPROVED:
INTER PLANT MATERIAL RATIONALISATION
COMMITTEE - MRC(CPO)

Rev. No.07	Amd. No.	Reaffirmed
Dt:26-05-2012	Dt:	Year:

Prepared HEEP, Haridwar	Issued Corp. R&D	Dt. of 1 st Issue Jan 1980
----------------------------	---------------------	--

COPYRIGHT AND CONFIDENTIAL
The Information on this document is the property of BHARAT HEAVY ELECTRICALS LIMITED.
It must not be used directly or indirectly in any way detrimental to the Interest of the company.

CORPORATE PURCHASING SPECIFICATIONS



specification. The raw materials used in the formulation of the priming paint shall be of good quality and conform to following Indian standards.

- | | |
|----------------------------------|-------------|
| a) Zinc Phosphate | : IS: 10897 |
| b) Red Oxide of Iron | : IS: 44 |
| c) Petroleum hydrocarbon solvent | : IS: 1745 |

The supplier of the material has to certify that the paint supplied shall be free from lead or its compounds and also meets the legislative requirements of ISO 14001.

8.0 TEST SAMPLES AND TEST METHODS:

Tender samples will not be required when once the type approval is given and the supplier concerned declared that the material for which the tender is given of the same quality as the type approved sample.

500ml of thoroughly mixed sample representing lot be drawn from randomly selected drum and shall be sent to laboratory for testing. The testing shall be done in accordance with relevant part and section of IS: 101 or as specified in this specification.

9.0 PROPERTIES:

9.1. Drying Time

Surface dry : 2 hours, maximum

Hard dry : 12 hours, maximum

9.2. Consistency

Smooth and uniform and suitable for brushing without appreciable drag on the brush or spraying as required.

Efflux time by Ford cup No. 4, at 27 ± 20°C: 80 - 120 secs.

9.3. Mass per Ten Litres:

13.5 kgs. min.

9.4. Flash Point:

30°C, min

9.5. Scratch Hardness:

When tested on coated panels air dried for 48 hrs and tested at a load of 1500g on steel panels and 1000g on tinned mild steel panels, no such scratch as to show the bare metal shall be produced.

9.6. Flexibility and Adhesion:

When tested on coated panels air dried for 48 hrs, no visible damage or detachment of coating shall take place and passes the test when tested by cylindrical bend test method.

9.7. Resistance to Salt Spray:

When tested as per test method of IS 2074, the test panel prepared from the followed by air drying for 48 hrs, material shall show no sign of corrosion after continuous exposure for 96 hrs, in salt spray cabinet.



CORPORATE PURCHASING SPECIFICATIONS

AA56101

Rev. No. 07

PAGE 3 of 5

9.8. Protection against Corrosion under Conditions of Condensations:

The coated panels air dried for 48 hrs, are subjected to continuous exposure, shall show no sign of deterioration of the coating & metal surface show no sign of corrosion.

9.9. COMPOSITION:

9.9.1. Pigment Content: 50 ± 5% by mass

9.9.2. Zinc Phosphate (IS 10897): 16.0%, min. by mass on pigment

9.9.3. Red Oxide AS Fe₂O₃ (IS 44): 50.0%, min. by mass on pigment

10.0 VOLUME SOLIDS: 40.0% min. (Pigment + Binder) by weight.

11.0 COMPATIBILITY TEST WITH COATS:

The primer paint shall be fully compatible with top coats like, High quality full glossy finishing paint conforming to AA56126 /IS 2932, when tested as per method prescribed in Annexure-1.

12.0 WET OPACITY (FOR INFORMATION ONLY):

Theoretical coverage: 10 sq.m / litre @ Dft: 35 microns.

13.0 TEST CERTIFICATES:

Unless otherwise stated, three copies of test certificates shall be supplied along with each consignment.

In addition, the supplier shall ensure to enclose one copy of the test certificates along with their despatch documents to facilitate quick clearance of the material.

The test certificates shall bear the following information:

AA56101 Rev. No. 07 - ANTI-CORROSIVE PRIMING PAINT

BHEL order:

Supplier's Name and address

Identification/Trade Mark, if any.

Batch No/Lot No.:

Date of Manufacture and Expiry.

Lot Quantity:

Test results of clause 7.0 to 12.0.

Special Instructions, if any.

14.0 KEEPING PROPERTY:

When the material stored in a covered dry place in the original sealed container at under ambient conditions, the same shall retain the properties prescribed in this specification for a period of at least 12 months after the date of manufacture, which shall not be subsequent to the date of placing the order and not earlier than one month of the scheduled delivery date mentioned in BHEL order.

CORPORATE PURCHASING SPECIFICATIONS



15.0 ENVIRONMENTAL REQUIREMENTS:

The supplier shall furnish Material Safety Data Sheet (MSDS) covering all information relating to human safety and environmental impacts of the hazardous materials particularly during their transportation, storage, handling and disposal along with each supply. Each container shall be marked with corresponding symbol and minimum worded cautionary notice for flammable / corrosive / toxic / harmful / irritant and oxidizing etc. as applicable.

16.0 PACKING & MARKING:

Unless otherwise stated, the paint shall be supplied in packing size as specified in BHEL order and shall be packed in air tight leak -proof metal container conforming to IS: 1407 and IS: 2552. Each container shall bear following information neatly written or pasted on the container.

AA56101 - ANTI-CORROSIVE PRIMING PAINT

BHEL order:

Name of supplier and address:

Identification/Trade Mark, if any.

Quantity of material:

Batch No/Lot No.:

Date of Manufacture and Expiry.

Special Instructions, if any:

17.0 REFERRED STANDARDS (Latest Publications Including Amendments):

- 1) IS : 44
- 2) IS : 101
- 3) IS : 1407
- 4) IS : 1745
- 5) IS : 2074
- 6) IS : 2552
- 7) IS : 2932
- 8) IS : 10897
- 9) IS : 12744
- 10) IS : 13262
- 11) ASTM D 3359
- 12) AA56126
- 13) AA56701



CORPORATE PURCHASING SPECIFICATIONS

AA56101

Rev. No. 07

PAGE 5 of 5

ANNEXURE-I

TEST FOR COMPATIBILITY OF ANTI-CORROSION PRIMING PAINT (AA 56101) WITH TOP COATS OF FINISHING PAINT (AA56126/IS: 2932)

The compatibility of anti-corrosive priming paint conforming to AA 56101 with top coat finishing paint to AA 56126/IS: 2932, shall be checked by Cross-cut tape adhesion method prescribed in ASTM D 3359. The adhesion tape used shall conform to IS: 13262 or any other tape bearing ISI mark having sufficient adhesion strength.

A Steel plate of size 150x100mm is taken for testing compatibility. Thoroughly clean the plate with emery to make it free from rust, oil, dust etc. Apply two coats of homogenized anticorrosive priming paint after allowing coating to dry over night before, application of next coat.

Apply two coats of top coat finishing paint evenly covering plate completely. Allow the coatings, to dry for 48 hours at ambient conditions before performing the cross cut adhesion test.

Test method B shall be followed and the acceptance criteria shall be 4 B, i.e., small flakes of the coating material are detached at intersections and less than 5% of the area is affected



CORPORATE STANDARD

AA 714 51 01

Rev. No. 04

PAGE 1 OF 3

STUDS, AUTOWELD, REDUCED BASE (WITHOUT BREAK OFF) COARSE PITCH, STEEL (M4-M16)

1.0 DESIGNATION:

A reduced base, autoweld stud (without break off), thread M10 length 50 mm, coarse pitch and made of steel shall be designated as:

1.1 On drawings:

- i) Material specification column : AA 714 51 01.
- ii) Description column : STUD ATOWLD RWBO M10X50-ST

1.2 On indents:

Stud Auto weld reduced base (without break off), steel M10X50: AA 714 51 01.

1.3 For issuing enquiries and on purchase orders:

While Issuing enquiries and purchase orders, enclose a copy of this BHEL standard.

2.0 COMPLIANCE WITH STANDARDS:

2.1 Dimensions, Tolerances and General requirements:

As per this BHEL standard AA 714 51 01.

2.2 Material:

Low Carbon Steel suitable for welding.

2.3 Threads:

Pitch-coarse to IS:4218, Part 2-1976.
Tolerance quality - Medium.
Tolerance class 6g.

2.4 Heat Treatment:

Case hardened.

2.5 Protective coating:

Studs will have plain anti-rust coating.

2.6 Finish: Plated as specified in BHEL order.

Revisions :

Cl. 24.8.34 of MOM of WG-F

APPROVED :

INTERPLANT
STANDARDIZATION COMMITTEE (WG-F)

Rev. No. 04

Amd.No.

Prepared

Issued

Dt. of 1st Issue

Dt:01.03.2004

Dt :

Year :

HARDWAR

Corp. R&D

January, 1977

**3.0 NOTE:**

3.1 These studs are commercially known as "Cyc-Arc steel studs"

3.2 Ferrule is to be supplied with every stud.

3.3 The coned end is flux metallised, thickness of metal deposit to be 0.15 to 0.20.

3.4 For welding, clearance etc: refer to BHEL standard AA 023 18 60.

3.5 For Autoweld, reduced base (with break off), steel studs refer to BHEL standard AA 714 51 05

3.6 Studs to this standard would be unplated, divisions wishing to have plated studs would have to get them plated.

3.7 Weights given in this standard are for general references only and are not meant for commercial transactions.

3.8 When fasteners are to be tested with in BHEL, sampling and acceptance shall be as per IS:1367 Part.17 instead of IS:2614 which was withdrawn..

4.0 REFERRED STANDARDS (Latest publications including amendments):

- 1) IS:1367 Pt.17 2) IS: 4218, Pt 2 3) AA 0231860 4) AA 7145105

EXPLANATORY NOTE:**This revision issued with the following changes:**

- In Cl: 1., thread size 10mm is modified as thread M10.
- Clause 2.0 'Material'(Rev 02) has been deleted due to duplication and all other clauses are renumbered.
- Sampling & Acceptance plan shall be as per IS:1367, Pt.17 in stead of IS:2614 which was withdrawn.
- Clause 4.0 'Referred standards' has been added.
- Four pages made into three pages.



TD-215
Rev.00

AMENDMENT-NOTIFICATION

HY 064 07 63 REV.NO.03

PAGE 1 OF 1

PROCESS SPECIFICATION FOR POST WELD HEAT TREATMENT OF CARBON STEEL AND LOW ALLOY STEEL PRESSURE VESSELS PARTS & OTHER COMPONENTS

The following clause shall be added in page no. 3 of 11, after clause 3.4.

Clause 3.4.1 Threaded portion of the weldments / components shall be protected or preserved by applying “ERPEDOL” compound

(Material Code no. is HY5510062002).

REF:	AMD.NO.	APPROVED	ISSUED	DATE	CUM. Sl.No.
HY:Tech:001	01	MANAGER, STDS. ENGG.	STDS. ENGG.	29.9.2001	A 0351



T D-218, Rev.00

PLANT STANDARD HYDERABAD

HY 064 07 63

REV.No. 03

PAGE 1 OF 11

PROCESS SPECIFICATION FOR POST WELD HEAT TREATMENT OF CARBON STEEL AND LOW ALLOY STEEL PRESSURE VESSELS PARTS & OTHER COMPONENTS

1.0 GENERAL:

1.1 This procedure outlines precautions/general guide lines to Technologists/Heat treatment personnel to ensure code requirements are fully met with during Post Weld Heat Treatment (PWHT) and is written in line with clauses UW-40, UCS-56 and UCS - 85.

1.2 For complete code requirements, relevant clauses/Tables shall be referred to.

1.3 Code requirements / code cases shall over rule this procedure in case of any discrepancy.

1.4 This procedure is applicable for coded vessels constructed with carbon steel and low alloy steels singularly stress relieved (whole or local) clubbed with other coded/non-coded vessels/weldments.

1.5 This standard stipulates guidelines for applications as per ASME Section VIII div.1. Specific jobs shall be postweld heat treated in consultation with welding engg dept.

1.6 The components/products for which the material specification is in accordance with National/ International codes such as IBR/BS/DIN/ASTM/ANSI/API, the post weld heat treatment requirements stipulated in the relevant codes shall be applicable.

2.0 COMPLIANCE WITH STANDARD:

This standard is based on ASME SECTION VIII, Division 1, Clauses UCS-56, UCS-85 and UW-40.

3.0 EQUIPMENT AND ITS CALIBRATION:

3.1 Heat treatment furnaces operating on electric power or gas or oil are suitable.

3.1.1 In case of thermocouple not placed on component, uniformity of temperature in the working zone shall be maintained within $\pm 14^{\circ}\text{C}$ during the operation.

3.2 Furnace shall be provided with suitable controller/recorder for temperature measurement. All controlling furnace instruments shall be calibrated as per QMI 001.

Revisions:
Brought in line with ASME Sec VIII, Div.1

Issued:
STANDARDS ENGINEERING SECTION

Rev.No. 03	Amd.No.	Reaffirmed	Prepared KLM	Approved AGM (G)	Dt.of Ist Iss. MAR.1985
Dt. DEC .94	Dt.	Year:			

COPYRIGHT AND CONFIDENTIAL
The information on this document is the property of BHARAT HEAVY ELECTRICALS LIMITED.
It must not be used directly or indirectly in any way detrimental to the interest of the company.

PLANT STANDARD

HYDERABAD



3.3 Location of the thermocouple shall be as per the guide lines given below (applicable for ASME coded vessels/ parts) and as per the details given in the technology process sheet of relevant part.

3.3.1 Placement of thermocouples must represent realistic temperature spread expected in the furnace both vertically and axially.

3.3.2 Two thermocouples are required on every single charge upto 5 meters long (zone). An additional thermocouple is required for every additional 5 meter or fraction there of. No two thermocouples may be placed more than 5 meters apart.

3.3.3 When more than one pressure vessel or pressure vessel parts are postweld heat treated in one furnace charge, each such vessel part shall be represented by atleast one thermocouple. Pressure vessels shall be so located such that it satisfies the requirement of clause 3.3.2.

3.3.4 Closure seams of pressure vessels locally or wholly heat treated will have two thermocouples placed 180° apart around the out side of the seam, on top and bottom or on the sides. In case of tube sheet to Hemihead joint (C1 joint) one thermocouple will be placed in tube hole near to center of the tube plate. However, for carbon steel tubed Heat exchanger, thermocouple at the centre is not required.

3.3.5 Fixing of themocouple prior to PWHT on the job shall conform to the procedure for fixing thermocouples as given below:

a) Thermocouple shall be fixed on the equipment with the help of fixing arrangement shown in figure below.

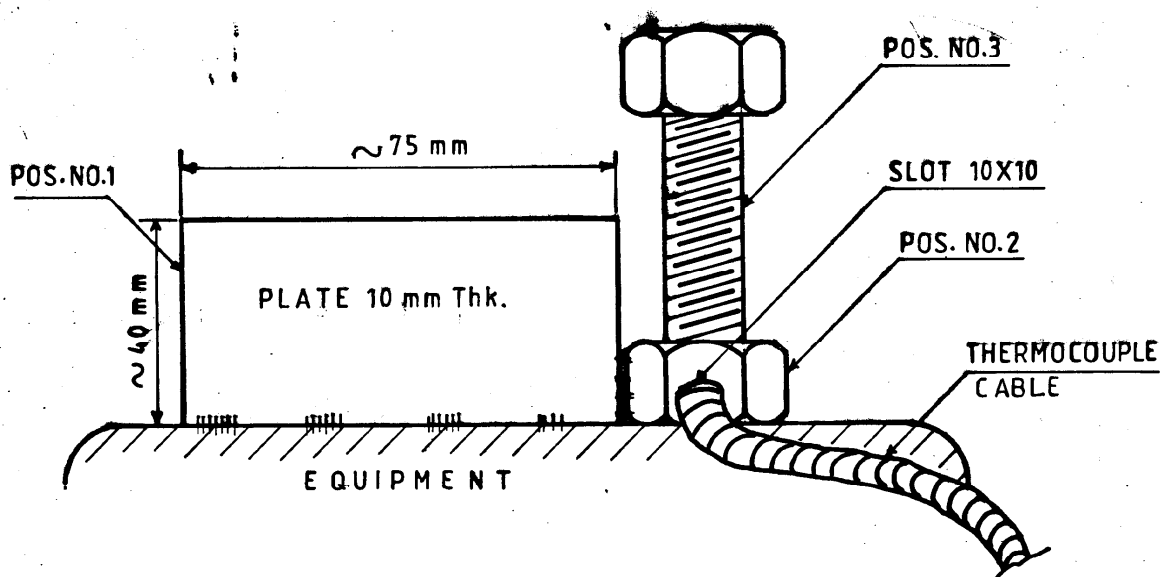

b) Material for Pos. No.1 shall be cut from pressure vessel quality carbon steel plates.



TD218-Rev.00

PLANT STANDARD HYDERABAD

HY 064 07 63

REV.No.

PAGE 3 OF 11

- c) Plate Pos.No.1 shall be tackwelded to the nut Pos.No.2 which is provided with a slot of 10x10 mm to facilitate insertion of thermocouple cable. Ensure the nut (Pos.No.2) bottom surface is flush with the plate (Pos.No.1) before tackwelding.
- d) Pos. No.1 shall be tackwelded to the equipment by qualified welder with approved WPS. The nut shall not be tackwelded to the equipment.
- e) Thermocouple cable shall be secured to the equipment by tightening bolt Pos.No.3 as shown in the fig. above.
- f) After PWHT, plate Pos.No.1 shall be removed from the equipment by grinding the tacks.

Do not hammer to break the tacks. Flush grind the tacks after removing the plate.

- 3.4 Components/pressure vessels shall be protected from the direct impingement of flame.
- 3.5 Quality control shall ensure conformity of the requirement stipulated in clause 3.1 to 3.4.
- 4.0 Simulated test coupons shall be proved wherever necessary for all materials used in the ASME code vessels except as permitted in UCS-85(d), (e), (f) and (g). The total time at temperature during simulation shall be at least 80% of the total time at temperature during actual heat treatment of the product and may be performed in a single cycle. Material of P.No.1, Gr.No.1 & 2 and all carbon steels and low alloy steels used in annealed condition are exempted from this requirement.
- 5.0 POST WELD HEAT TREATMENT (PWHT) CYCLE:
- 5.1 All materials in the PWHT charge shall be categorised as per 'P' number and group no. according to ASME Section IX - Clause QW-422. For weldments involving non ASME materials, P numbers and group no. shall be assigned based on nearest equivalent ASME material specification.
- 5.2 Outline special requirements/instructions if any from drgs/Route cards/material specifications. Necessary information shall be filled in Furnace loading sheet No. PD-316 enclosed.
- 5.3 Clubbing of non ASME material with coded vessels shall be considered only when such requirements are acceptable to code specified PWHT Cycle.
- 5.3.1 For assembly of materials of different P numbers, the postweld heat treatment shall be the lowest range of the material requiring the higher postweld heat treatment temperature after giving due consideration to the mass of the material involved.
- 5.4 The temperature of the furnace shall not exceed 425°C at the time of loading.

PLANT STANDARD HYDERABAD



5.5 Rate of heating:

5.5.1 Rate of heating above 425°C shall not be more than 222°C/hr divided by the maximum metal thickness of the shell or head plate in inches, but in no case more than 222°C/hr. Maximum metal thickness in coded vessel or other weldments in the charges, whichever is maximum shall be used in the calculation. During the heating period there shall not be greater variation in temperature throughout the portion of the vessel being heated than 138°C within any 4.6 M interval of length.

5.5.1.1 The rate of heating and cooling need not be less than 55°C/hr. However, the reduced rates of heating and cooling for closed chambers and complex structures may be considered to avoid distortion due to excessive thermal gradient.

5.6 Soaking Temperature and Time:

5.6.1 Minimum holding time and temperature shall be as per table UCS-56 as given in annexure-1.

A temperature range of 50°C shall be specified starting from code specified minimum normal holding temperature which may be relaxed to 60°C range to facilitate clubbing with vessels constructed to codes other than ASME Sec.viii Div.1.

5.6.2 Wherever impracticable, PWHT at minimum normal holding temperature can be considered as permitted by table UCS 56.1 as given in the annexure-2.

5.6.3 For assessing min. holding time, the nominal thickness shall be the thickness of weld joint as defined in UW-40 (f).

5.6.4 For combined charge the min. holding temperature is the max. of the min. normal holding temperatures of the applicable materials in the charge as per 5.6.1 above. Holding temperatures lower than the min. normal holding temperatures (clause 5.6.2) can be considered only when such temperature is acceptable for all materials in the charge.

5.6.5 For combined charge, the min. holding time is the max. of the min. holding times for various weldments as calculated in applicable clauses 5.6.1, 5.6.2 and 5.6.3 above.

5.6.6 For vessels requiring notch toughness properties (low temp. application, customer requirement etc.) which are post weld heat treated singularly or clubbed with other components/vessels; Soaking time shall be specified in consultation with welding engineering.



TD218 Rev.00

PLANT STANDARD

HYDERABAD

HY 064 07 63

REV.No.03

PAGE 5 OF 11

- 5.7 Rate of Cooling:
- 5.7.1 Above 425°C, cooling shall be done in a closed furnace or cooling chamber at a rate (vide clause 5.5.1.1 also) not greater than 278°C/hr divided by the maximum metal thickness of the shell or head plate in inches, but in no case more than 278"/hr. From 425°C the vessel may be cooled in still air.
- 6.0 LOCAL POSTWELD HEAT TREATMENT:
- 6.1 Wherever not practicable, circumferential joints may be locally post weld heat treated by gas fired split furnace or by electrical heating which shall ensure required uniformity.
- 6.2 The width of the heated band on each side of the greatest width of finished weld shall be not less than two times the shell thickness.
- 6.3 The portion outside the heating device shall be protected so that the temperature gradient is not harmful.
- 7.0 POWER/GAS FAILURE DURING PWHT CYCLE:
- 7.1 Safety precautions on power / gas failure.
- 7.1.1 Ensure isolation of gas line by closing gate valve on gas inlet line.
- 7.1.2 Fully open all dampers.
- 7.1.3 Close all burners.
- 7.2 Safety precautions before recharging.
- 7.2.1 Open main door.
- 7.2.2 Purge residual gases in furnace, by operating air blower.
- 7.3 Record time and date of gas / power failure and restart of the furnace on the chart.
- 7.4 Repeat PWHT cycle as per loading chart. Starting temperature for the cycle shall be the existing job temperature.
- 8.0 INSPECTION AND CERTIFICATION:
- 8.1 Heat treatment chart shall be certified by Shop QC/third party inspection as per Route card/Quality plan requirements.
- 9.0 REFERRED STANDARDS:
ASME Sec.VIII Div.I

COPYRIGHT AND CONFIDENTIAL
The information on this document is the property of BHARAT HEAVY ELECTRICALS LIMITED.
It must not be used directly or indirectly in any way detrimental to the interest of the company.

PLANT STANDARD

HYDERABAD



ANNEXURE - 1

TABLE UCS - 56.1

ALTERNATIVE PWHT REQUIREMENTS FOR CARBON AND LOW ALLOY STEELS

(Applicable only when permitted in table UCS-56)

Decrease in temperature below the min. specified temperature °C	Minimum holding time [Note (1)] at decreased temperature (hrs)	Note
28°C	2	--
56°C	4	--
84°C	10	(2)
112°C	20	(2)

Note: (1) Minimum holding time for 25mm thickness or less, Add 15 minutes per 25mm for thickness greater than 25 mm.

(2) The above lower PWHT temperatures permitted only for P No.1 Gr. No.1 and 2 materials.

COPYRIGHT AND CONFIDENTIAL
 The information on this document is the property of BHARAT HEAVY ELECTRICALS LIMITED.
 It must not be used directly or indirectly in any way detrimental to the interest of the company.



TD218-Rev.00

PLANT STANDARD HYDERABAD

HY 064 07 63

REV.No. 03

PAGE 7 OF 11

ANNEXURE - II

POSTWELD HEAT TREATMENT REQUIREMENTS FOR CARBON AND LOW ALLOY STEELS

Sl. No.	BHEL Specification (Base Standard)	ASME Equivalent	Product Form	Nominal Holding Temperature (°C) Minimum	Minimum Holding Time	Remarks
1.	AA 10108 (IS 2062, Gr. A)	--	Sheet	600	≤ 50 : 2 hr + 15 minutes $> 50 \leq 125$: 1 hr/25mm minimum > 125 : 2 hr + 15 minutes	Refer Notes 1, 2, 3 of table UCS-56 also
2.	AA 10112 (Low Carbon Steels) (IS 9550, Gr. 20)	--	Bars section	600	≤ 50 : 15 minutes minimum $> 50 \leq 125$: 2 hr + 15 minutes > 125 : 2 hr + 15 minutes	Refer Notes 1, 2, 3 of table UCS-56 also
3.	AA 10119 (IS 2062, Gr. B)	--	Pl, Sh, section bars	600	"	"
4.	AA 10122 (IS 961 Gr. Fe 540 W.Hr)	--	Plates	600	"	"
5.	AA 10152 (IS 1239 pt.1 ERW)	--	Tubes	600	"	"
6.	AA 10156 (ASTM A 179)	SA 179	Tubes	600	"	"
7.	AA 10157 (ASTM A 179)	SA 179	Tubes	600	"	"

PLANT STANDARD
HYDERABAD



Sl. No.	BHEL Specification (Base Standard)	ASME Equivalent	Product Form	Nominal Holding Temperature °C (Minimum)	Minimum Holding Time at Normal	Remarks
8.	HY 10192 (DIN:2391) Gr. St35-NBK		Tubes	"	"	"
9.	HY 10193 (DIN:2391) St52-NBK		Tubes	"	"	"
10.	HY 10194 (IS 3601) CDS-430		Tubes	"	"	"
11.	HY 10198 (ASTM A 36)	SA 36	Section	"	"	"
12.	HY 10199 (IS1570 pt. II) Gr. 15C8		Bars	"	"	"
13.	HY 10408 (ASME SA 516) Gr. 70	ASME SA516 Gr. 70	Plates	600	"	"
14.	AA 10455	SA106 Gr. B	Pipes	600	"	"
15.	HY 10470	SA516 Gr. 70	Pipes	600	"	"

COPYRIGHT AND CONFIDENTIAL
 The information on this document is the property of BHARAT HEAVY ELECTRICALS LIMITED.
 It must not be used directly or indirectly in any way detrimental to the interest of the company.



ID-218-REV.00

PLANT STANDARD
HYDERABAD

HY 064 07 63

REV.No. 03

PAGE 9 OF 11

Sl. No.	BHEL Specification (Base Standard)	ASME Equivalent	Product: Form	Nominal: Holding Temp °C (f)	Minimum: Holding Temperature	Remarks
16.	P1 : AA 19931 Gr.1 : IS 2004 Cl.2	-	Forging	600		"
17.	- : AA 19341 (IS4367 20C15)	SA105	Forging	600		"
18.	- : HY 19361	SA105	Forging	600		"
19.	- : HY 19364	SA350 LF2	Forging	600		"
20.	Gr.2 : HY 19366	SA266 Cl.2	Forging	600		"
21.	- : AA 19511 (ASTM A 216 WCC:Gr.WCC)	SA216	Casting	600		"
22.	- : AA 19521 (IS 2708 Gr.1)	--	Casting	600		"
23.	- : HY 19561 (ASTM A 352 LCB)	(SA352 LCB)	Casting	600		"
24.	- : HY 19562 (ASTM A 216 WCA:Gr.WCA)	SA216	Casting	600		"
25.	- : HY 19569 (DIN17245 : GS-C25)	SA216	Casting	580		"

PLANT STANDARD
HYDERABAD



Sl. No.	BHEL Specification (Base Standard)	ASME Equivalent	Product Form	Nominal Holding Temperature °C (Minimum)	Minimum Holding Time at Normal Temperature	Remarks
26.	HY 19570 (DIN 17245 GS-C25)	SA216 Gr. WCA	Casting	580	"	"
27.	P3 (C-Mn Steel) HY 19571 (DIN 17245) GS-22Mo4		Casting	660	1hr/25mm minimum 2h + 15 minutes for each additional 25mm over 50 mm	Refer 1, 2, 3, 4 of table UCS-56
28.	P4 (1Cr 1/2Mo) AA 10632	SA335 P11	Plates	600	1hr/25mm minimum 5hr + 15 min. for each additional 25mm over 125mm	Refer 1, 2 of table UCS-56
29.	P4 (1Cr 1/2Mo) HY 19387	SA182 F11	Forging	600	"	"
30.	P5 (2 1/4Cr 1 Mo) Gr. 1 AA 10630	SA335 P22	Pipes	680	"	Refer notes 1, 2, 3 of table UCS-56
31.	ASME SA387 Gr. 5	SA 387 Gr. 5	Plates	680	"	"

COPYRIGHT AND CONFIDENTIAL
The information on this document is the property of BHARAT HEAVY ELECTRICALS LIMITED. It must not be used directly or indirectly in any way detrimental to the interest of the company.

COPYRIGHT AND CONFIDENTIAL
 The information on this document is the property of BHARAT HEAVY ELECTRICALS LIMITED.
 It must not be used directly or indirectly in any way detrimental to the interest of the company.



TD-218-Rev.00

PLANT STANDARD HYDERABAD

HY 064 07 63

REV.No. 03

PAGE 11 OF 11

Sl. No.	BHEL Specification (Base Standard)	ASME Equivalent	Product Form	Nominal Holding Temperature °C (Minimum)	Minimum Holding Time at Normal	Remarks
32.	P6 (13%Cr Stainless steel)	--	Casting	540-560	"	"
<p style="text-align: center;">Note: Maximum holding temperature shall be 30°C below the actual tempering temperature of the parts/components.</p>						



FURNACE LOADING SHEET

1. HEAT TREATMENT DETAILS:

CYCLE NO: _____

1.1 TYPE OF TREATMENT : STRESS RELIEVING (FURNACE/LOCAL)

DATED:- _____

1.2 RATE OF HEATING ABOVE 425°C:

1.2.1 AS PER CODE : (MAXIMUM) :

1.2.2 RESTRICT TO : (MAXIMUM) :

1.3 SOAKING TEMPERATURE :

1.4 SOAKING TIME (MINIMUM) : ; MAXIMUM :

1.5 RATE OF COOLING UPTO 425°C

1.5.1 AS PER CODE (MAXIMUM) :

1.5.2 RESTRICT TO (MAXIMUM) :

1.6 TYPE OF COOLING : FURNACE COOLING

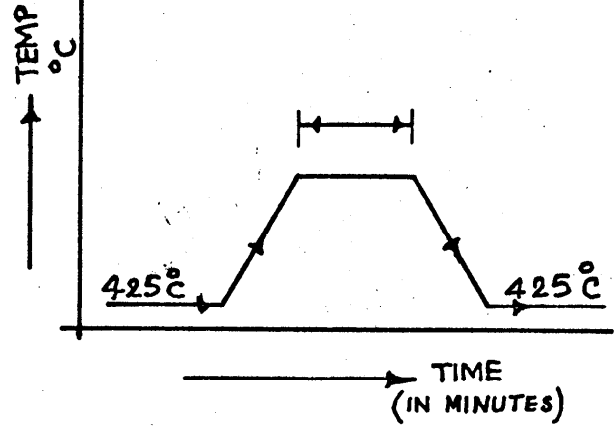

SL. NO.	WORK ORDER	PART NO:	DESCRIPTION	QTY.	TOTAL WEIGHT	P.NO TO P.NO	WPS NO.	GOVERNING THK-FOR	
								HEATING/COOLING RATES	SOAKING

THERMO COUPLE POSITION

REMARKS

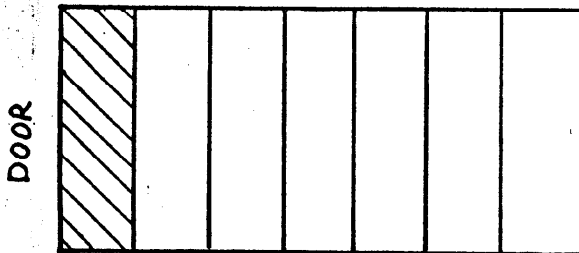

APPROVED

(FABRICATION TECHNOLOGY)

CLEARANCE BEFORE STARTING THE CYCLE

(QUALITY CONTROL)

DATE OF LOADING;

DATE OF CHARGING;

DT. & SHIFT	OPERATION INCHARGE	ACTUAL TIME		REMARKS
		STARTING	COMPLETION	
				HEATING SOAKING COOLING

THERMOCOUPLE INDICATION:

<u>SNO.</u>	<u>CALIBRATION DUE DATE</u>	<u>COLOUR</u>	<u>SNO.</u>	<u>CALIBRATION DUE DATE</u>	<u>COLOUR</u>
-------------	-----------------------------	---------------	-------------	-----------------------------	---------------

1. -----

4. -----

2. -----

5. -----

3. -----

6. -----

RECORDER NO. DUE DATE OF CALIBRATION.

(PRODUCTION INCHARGE)

H.T. CHART REF. NO.

REVIEWED AND ACCEPTED. RELEASED FOR FURTHER OPERATIONS.

(QUALITY CONTROL)



**BHEL HERP VARANASI
QUALITY PLAN**

QUALITY PLAN FOR

FABRICATED & MACHINED COMPONENT (MILD STEEL)

SL.NO.	COMPONENT	CHARACTERISTIC CHECKED	TYPE/METHOD OF CHECK	EXTENT OF CHECK	REFERENCE DOCUMENTS & ACCEPTANCE NORM	FORMAT OF RECORD	AGENCY			REMARKS
							P	W	V	
1.0	Raw Material									
	i. Plate material, Rounds, Pipes (Specns. as applicable)	Verification of supplier's certificates for chem. & mech. Properties	Certificate review	100%	IS2062 FOR MS PL. IS228 FOR MS ROD SA106 GR.B FOR seamless stl. PIPE, En8 /En19 FOR RODs	T.C.	3	-	2	Matl. TC can be waived off if the same is specified in Purchase Order
		Soundness of MS Plates > 40 mm thk.	UST		100%	ASTM A-435	T.C.	3	-	2
	ii. Standard Fasteners (Bolts, Nuts, screws)	Verification of make and class	review of sub supplier's documents	100%	Drawing / purchase order	Inspection Report	3	-	2	All Fasteners of class 8.8 and above should be of reputed make like TVS/LPS/DFL/Bolmaster/CAPARO/Sri Pavitra make
2.0	Fabrication	i. Visual inspection of welds	Visual	100%	Free from defects	Inspection Report	3/2	-	2	Welding shall be done as per WPS mentioned in the drawing. DP test o be witnessed by BHEL if asked in the PO
		ii. Soundness of welded joints	DP Test of welded joints (if required as given in the Drg./PO)	as mentioned in Drg. / Po	AA0850131 & AA0850129	Inspection Report	3	2	-	
		iii. Verification of Dimensions and visual inspection	visual & Measurement	100% by Vendor	Drawing.	Dimension Report	3	-	2	
		iv. Stress relieving after welding (when called in Drg. or PO)	Review of H.T.Chart	100%	HY0640763	H.T.Chart	3	-	2	
3.0	Final Inspection	i. Overall dimensions after final machining	Measurement	100% for machined dimensions and random 10% for other dimensions	Drawing.	Dimension Report	3/2	2	-	Tol. For untol. Dimensions will be governed by IS2102 med. Grade for machined dimensions and Course grade for Fabricated dimensions
		ii. surface finish	Visual	100%	Drawing	Inspection Report	3/2	2	-	
		iii. Painting/preservation	Visual, Paint shade and DFT	Random Sample basis	Drawing / PO		3/2	-	2	Surface preparation shall be done by sand/grit/shot blasting/local grinding (case to case basis) prior to painting. Machined surfaces shall be protected during surface preparation. All unmachined surfaces shall be protected by applying two coats of Zinc phosphate primer (specn. AA56101). All machined surfaces shall be protected by applying Apply 1 Coat of Rust Preventive Hard Film yellow (AA55155) and 1 Coat of Rust Preventive Hard Film Black (AA55154). Very small machined components can be wrapped in polythene sheets after applying liberal amount of grease. Threaded holes shall be protected by applying grease. External threads shall be protected by PV sleeve.
		iv. Identification & Marking	Punching of P.O.No. & Inspector Seal	100% by BHEL		Inspection Report	3/2	2	-	
QP. NO.	RV/FAB & MCD/12 REV-03		APPROVED BY		MANAGER P&D					
DATE	26.08.2017		SIGNATURE & DATE		<i>Virendra Kumar</i>					
PG. NO.	1 OF 1									

विरेंद्र कुमार / Virendra Kumar
 उप महाप्रबंधक (पी.एण्ड.डी.)
 भारत हेवी इलेक्ट्रिकल्स लि.
 Varanasi

T.C. = TEST CERTIFICATE
 P = PERFORM
 W = WITNESS
 V = VERIFY
 1 = VENDOR
 2 = BHEL



BHARAT HEAVY ELECTRICALS LIMITED

RAMACHANDRAPURAM, HYDERABAD-500 032.

PD - 268

QW-482 WELDING PROCEDURE SPECIFICATION (WPS)

Welding Procedure Specification No. WE.Q01. Date 2.4.94. Supporting PQR No. 185 + 21

Revision No 2. Date 15.09.1993

Welding Process (es) SMAW Type (s) Manual

JOINTS (QW 402)

Details

Joint Design AS per manufacturer's Drawing

Backing (Yes) & back strip (No) For double sided joints For single side joints

Backing Material (Type) Weld metal for double side welding and Pi for backing strip joints.

Metals Yes Non fusing metal

BASE METALS (QW-403)

P. No. 1. Group No. 1 & 2 to P. No. 1. Group No. 1 & 2

OR

Specification type and grade

to Specification type and grade

OR

Chem. Analysis and Mech. Prop.

to Chem. Analysis and Mech. Prop.

Thickness Range :

Base Metal : Groove 4.75 - 200mm Fillet All

Pipe Dia. Range : Groove All dia Fillet All

Other Root spacing for backing strip joints : 8-10mm

For others : 2 + 1mm

FILLER METALS (QW-404)

Spec No. (SFA) 5.1

AWS No. (Class) E 7018

F. No. 4

A. No. 1

Size of Filler Metals ϕ 2.5 to 6.3mm

Deposited Weld Metal

Thickness Range : Groove 200mm Max

Fillet All

Electrode Flux (Class) Basic

Flux Trade Name NA

Consumable Insert No : Retainers : no

Bead thickness : 5mm Max.

POSITIONS (QW-405)

Position [s] Groove All

Welding Progression : Up For V Down

Position [s] Fillet All

PREHEAT [QW 406] Upto 30mm 10°C

Preheat Temp Min From 31-100mm 100°C

Interpass Temp. Max Above 100mm 150°C
350°C

Preheat Maintenance Nil

[POSTWELD HEAT TREATMENT QW-407]

Temperature Range 600°C - 650°C

Time Range As per UCS - 56

GAS [QW-408]

Percent Composition NA

Gas [es] [Mixture] Flow Rate

Shielding ---

Trailing ---

Backing ---

ELECTRICAL CHARACTERISTICS [QW-409]

Current AC or DC DC Polarity Reverse (+Ve)

Amps [Range] 60-300 Volts Range 22-26

Tungsten Electrode size, and type NA

Mode of Metal Transfer for GMAW NA

Electrode wire feed speed range NA

TECHNIQUE [QW-410]

String or Weave Bead String & Weave Orifice or Gas Cup Size NA

Initial and Interpass Cleaning Chipping, Brushing, Grinding

Method of Back Gouging By Grinding Oscillation NA

Contact Tube to Work Distance NA Multiple or Single Pass Multi

Multiple or single Electrodes Single Travel Speed [Range] NA

Peening Not Allowed Electrode Spacing NA

Other Clean 20mm width on either side of the weld area prior to weld to remove paint, Oil, Grease etc.

Weld Layer [s]	Process	Filler Metal		Current		Volt Range	Travel Speed Range mm/min	Other
		Class	Dia. mm	Type Polar	Amp. Range			
	SMAW	E7018	2.5	DC +	60-90	---	---	String & Weave Max - 3D
	SMAW	E7018	3.15	DC +	90-140	---	---	
	SMAW	E7018	4.0	DC +	140-180	---	---	
	SMAW	E7018	5.0	DC +	180-240	---	---	
	SMAW	E7018	6.3	DC +	240-300	---	---	

Kfm.

PREPARED BY 

SR. MANAGER 
WELDING ENGG.