

**Enquiry No GEM/2022/B/1973097 dt 22.02.2022**  
**Procurement of Carbon Steel Welded Pipes for Khurja Project**

Date – 16.03.2022

Dear Sir / Madam,

**Sub:** Procurement of Carbon Steel Welded Pipes for Khurja Project as per BHEL Enquiry - GEM/2022/B/1973097 dt 22.02.2022.

With regard to the subject tender for the procurement of “**Carbon Steel Welded Pipes for Khurja Project**” as per BHEL Enquiry No GEM/2022/B/1973097 dt 22.02.2022, Corrigendum #3 is being issued for inclusion of revised production notes, EP drawing, QP and inspection terms in the bid specific ATC.

Prospective bidders are requested to take note and submit / revise their quote before the due date **23.03.2022 (14.00 hrs)**.

For BHEL Piping Centre,

Poongkodi.V  
DM / Purchase  
BHEL Piping Centre

**ANNEXURE-A**

**BID SPECIFIC ADDITIONAL TERMS & CONDITIONS FOR THE  
PROCUREMENT OF CARBON STEEL WELDED PIPES FOR KHURJA PROJECT**

SI No	BHEL requirement	Agree / Disagree																								
1	<p><b>SCOPE OF SUPPLY-</b></p> <p>i) Manufacture / Fabrication &amp; Supply of Rolled and welded pipes made of IS2062 plates / IS 10748 coils meeting BHEL drawing &amp; technical requirements for KHURJA Project.</p> <p>ii) To be delivered at KHURJA project site.</p> <table border="1" data-bbox="126 474 1425 709"> <thead> <tr> <th>ITEM NO.</th> <th>MATERIAL CODE</th> <th>PIPE DESCRIPTION</th> <th>QTY IN METERS</th> <th>WT IN MT</th> <th>F.O.R DESTINATION</th> </tr> </thead> <tbody> <tr> <td>1</td> <td>159387202001</td> <td>PF PIPE OD3632x16thk IS2062 GRADE-E250BR (UG)</td> <td>1430</td> <td>2040.18</td> <td>KHURJA Project Site</td> </tr> <tr> <td>2</td> <td>159387212001</td> <td>PF PIPE OD2628x14thk IS2062 GRADE-E250BR (UG)</td> <td>820</td> <td>740.009</td> <td>KHURJA Project Site</td> </tr> <tr> <td colspan="3"><b>Total Quantity</b></td> <td><b>2250</b></td> <td><b>2780.19</b></td> <td></td> </tr> </tbody> </table>	ITEM NO.	MATERIAL CODE	PIPE DESCRIPTION	QTY IN METERS	WT IN MT	F.O.R DESTINATION	1	159387202001	PF PIPE OD3632x16thk IS2062 GRADE-E250BR (UG)	1430	2040.18	KHURJA Project Site	2	159387212001	PF PIPE OD2628x14thk IS2062 GRADE-E250BR (UG)	820	740.009	KHURJA Project Site	<b>Total Quantity</b>			<b>2250</b>	<b>2780.19</b>		
ITEM NO.	MATERIAL CODE	PIPE DESCRIPTION	QTY IN METERS	WT IN MT	F.O.R DESTINATION																					
1	159387202001	PF PIPE OD3632x16thk IS2062 GRADE-E250BR (UG)	1430	2040.18	KHURJA Project Site																					
2	159387212001	PF PIPE OD2628x14thk IS2062 GRADE-E250BR (UG)	820	740.009	KHURJA Project Site																					
<b>Total Quantity</b>			<b>2250</b>	<b>2780.19</b>																						
2	<p><b>TECHNICAL REQUIREMENT-</b></p> <p><b><u>A) PIPE REQUIREMENT</u></b></p> <p>i) Rolled and welded pipes made of IS2062 plates / IS 10748 coils shall be manufactured / fabricated (as applicable) and supplied meeting BHEL Technical Delivery Condition 7488:TDG:001, Rev 00 dt 08.02.2022.</p> <p>ii) Pipes shall be supplied as per Drawing No. 3-80-468-36924-R01 (Refer production notes). Tolerance on total length of pipe given in Note: 02 is for manufacturing purpose only. Payment shall be made as per length mentioned in enquiry / PO or actual length supplied whichever is less.</p> <p>iii) Edge preparation shall be as per drawing 4-80-468-84546-R00.</p> <p>iv) Spider arrangement shall be as per drawing 4-80-999-93078-R01.</p> <p>v) WPS/PQR available with bidder shall be submitted.</p> <p>vi) Typical Quality plan available with bidder shall be submitted.</p> <p>vii) Bidder shall submit detailed process flow chart from raw material stage including manufacturing of pipe, Edge Preparation, coating &amp; testing.</p> <p>viii) Bidder shall submit valid ISO 9001:2015 certificate or Quality Management system Certificate or written down procedure.</p> <p>ix) Submit duly filled in Unpriced bid enclosed (Annexure-B).</p> <p>x) Submit duly filled in Checklist enclosed along with supporting documents (Annexure-C).</p> <p>xi) Submit duly filled in Pre-Qualification Criteria along with supporting documents (Annexure-D).</p> <p>xii) Bids qualifying the PQR conditions shall be evaluated for techno-commercial soundness. Techno-Commercially qualified bidders will be taken up for Customer approval, if required. Credentials for Customer approval shall be submitted, if required. Additional documents will be sought from the bidders, if necessary. Price bids of only such Techno-Commercially qualified and Customer approved bidders will be considered for further tender processing.</p> <p><b><u>B) COATING REQUIREMENT</u></b></p> <p>Project specific painting scheme ref KHURJA - QP NO: 7488: QPC: 12 Rev. 00 dt.07.02.2022 shall be applicable.</p>																									
3	<p><b>QUALITY PLAN</b></p> <p>After placement of Purchase order vendor shall submit Quality plan for manufacture / fabrication of pipe, meeting the agreed tender requirements in line with BHEL Technical Delivery Condition 7488:TDG:001, Rev 00 dt 08.02.2022 for review/approval immediately within 7 days from date of PO. QP approval shall be provided within 15 days from the date of clear QP.</p> <p>MQP shall be approved by BHEL &amp; Customer. Manufacturing / Fabrication shall commence subjected to approval of above QP by BHEL &amp; Customer.</p>																									
4	<p><b>VALIDITY OF OFFER-</b></p> <p>The quotation shall be valid at least for a period of <b>90 days from the date of technical bid opening / 60 days from the date of price evaluation</b> whichever is later. Offer with lesser validity may not be considered.</p>																									

**ANNEXURE-A**

**BID SPECIFIC ADDITIONAL TERMS & CONDITIONS FOR THE  
PROCUREMENT OF CARBON STEEL WELDED PIPES FOR KHURJA PROJECT**

5	<p><b>DELIVERY PERIOD-</b> <b>Delivery is the essence of the contract.</b> <b>For Item No: 1,</b> PF PIPE OD3632x16thk IS2062 GRADE-E250BR (UG) – delivery of <b>1500MT within 120 DAYS</b> from the date of Purchase order &amp; balance <b>540MT within 150 DAYS</b> from the date of Purchase order.</p> <p><b>For Item No: 2,</b> PF PIPE OD2628x14thk IS2062 GRADE-E250BR (UG) – delivery within <b>120 DAYS</b> from the date of Purchase order.</p> <p>However, early delivery is preferable.</p> <p>Bidders to submit self-declaration for the annual Installed Capacity &amp; monthly production capacity. Self-declaration is mandatory. Only such bidders meeting the production capacity mentioned in the enquiry shall be considered for price evaluation (<b>Minimum capacity per month for Item No. 1 – 400MT, Item No. 2 – 150 MT &amp; if quoting for Item Nos. 1 &amp; 2 – 550 MT</b>).</p>																									
6	<p><b>LIQUIDATED DAMAGES-</b> If the bidder fails to deliver the item within the period specified in the contract the purchaser shall deduct Liquidated Damages, a sum equivalent to 0.5% of the price for each week of delay up to a maximum of 10% of the price of delayed/undelivered portion.</p> <p><b>LD will be reckoned from the date of Lorry way bill / Invoice / E-way bill whichever is later.</b></p>																									
7	<p><b>DELIVERY TERM-</b> 'FOR' KHURJA Project Site (all incl of P&amp;F, F&amp;I, testing, inspection charges etc).</p>																									
8	<p><b>EVALUATION &amp; ORDERING-</b></p> <ol style="list-style-type: none"><li>1. Evaluation of bids and ranking of bidders shall be done item wise.</li><li>2. Quoted rates shall be <b>inclusive of GST.</b></li></ol> <p><b>Successful L1 bidder shall furnish price break-up in the following format:</b></p> <table border="1"><thead><tr><th>SI No</th><th>Pipe Description</th><th>Qty in metres</th><th>Pipe Base price / meter in INR</th><th>External painting / meter</th><th>Freight &amp; Insurance / meter</th><th>All inclusive rate / meter</th><th>Total value T = All inclusive rate / Meter X Qty</th></tr></thead><tbody><tr><td style="text-align: center;">1</td><td></td><td></td><td></td><td></td><td></td><td></td><td></td></tr><tr><td style="text-align: center;">...</td><td></td><td></td><td></td><td></td><td></td><td></td><td></td></tr></tbody></table> <p><b>THIS IS A FIXED PRICE CONTRACT AND PRICES ARE FIRM TROUGHOUT THE EXECUTION OF THE CONTRACT.</b></p>	SI No	Pipe Description	Qty in metres	Pipe Base price / meter in INR	External painting / meter	Freight & Insurance / meter	All inclusive rate / meter	Total value T = All inclusive rate / Meter X Qty	1								...								
SI No	Pipe Description	Qty in metres	Pipe Base price / meter in INR	External painting / meter	Freight & Insurance / meter	All inclusive rate / meter	Total value T = All inclusive rate / Meter X Qty																			
1																										
...																										
9	<p><b>PREFERENCE TO MAKE IN INDIA PRODUCTS (FOR BIDS &lt; 200 CRORE)-</b> Preference shall be given to Class 1 local supplier as defined in public procurement (Preference to Make in India), Order 2017 as amended from time to time and its subsequent Orders/Notifications issued by concerned Nodal Ministry for specific Goods/Products. The minimum local content to qualify as a Class 1 local supplier is denote in the bid document. If the bidder (manufacturer) wants to avail the Purchase preference, the bidder must upload a certificate (<b>as per Annexure-E</b>) regarding the percentage of the local content and the details of locations at which the local value addition is made along with their bid, failing which no purchase preference shall be granted. In case the bid value is more than Rs 10 Crore, the declaration relating to percentage of local content shall be certified by the statutory auditor or cost auditor, if the OEM is a company and by a practicing cost accountant or a chartered accountant for OEMs other than companies as per the Public Procurement (preference to Make-in -India) order 2017 dated 04.06.2020.</p> <p>Only <b>Class-I and Class-II Local suppliers</b> as per MII order dated 4.6.2020 <b>will be eligible to bid</b>. Non - Local suppliers as per MII order dated 04.06.2020 are not eligible to participate. However, eligible micro and small enterprises will be allowed to participate. In case Buyer has selected Purchase preference to Micro and Small Enterprises clause in the bid, the same will get precedence over this clause.</p> <p><b>Class-I and Class-II Local suppliers meeting the production capacity requirements as mentioned under Point 5 – Delivery shall be given Purchase Preference for MII.</b></p>																									

**ANNEXURE-A**

**BID SPECIFIC ADDITIONAL TERMS & CONDITIONS FOR THE  
PROCUREMENT OF CARBON STEEL WELDED PIPES FOR KHURJA PROJECT**

10	<p><b>PURCHASE PREFERENCE TO MICRO AND SMALL ENTERPRISES (MSES)-</b> Purchase preference will be given to MSEs as defined in Public Procurement Policy for Micro and Small Enterprises (MSEs) Order, 2012 dated 23.03.2012 issued by Ministry of Micro, Small and Medium Enterprises and its subsequent Orders / Notifications issued by concerned Ministry. If the bidder wants to avail the Purchase preference, the bidder must be the manufacturer of the offered product in case of bid for supply of goods. Traders are excluded from the purview of Public Procurement Policy for Micro and Small Enterprises. <b>Udyam Registration certification shall be submitted.</b></p> <p>If L-1 is not an MSE and MSE Seller (s) has/have quoted price within L-1+ 15% (Selected by Buyer) of margin of purchase preference / price band defined in relevant policy, such Seller shall be given opportunity to match L-1 price and contract will be awarded for 25% (selected by Buyer-rounded up to the nearest whole number) percentage of total QUANTITY.</p> <p><b>MSE suppliers meeting the production capacity requirements as mentioned under Point 5 – Delivery shall be given Purchase Preference for MSE.</b></p>	
11	<p><b>GUARANTEE-</b> The materials are to be guaranteed for satisfactory performance for a period of 24 months from the date of dispatch or 18 months from the date of commissioning / putting into use whichever is earlier. Pipe suppliers shall guarantee for the coating on the pipes also.</p> <p>Any defect noticed during the above period, the same shall be rectified / replaced free of cost on FOR destination basis within a reasonable time, maximum limited to the agreed delivery period, to the satisfaction of BHEL and the End User.</p> <p>To this effect a guarantee certificate should be sent along with the dispatch documents in the event of an order. No deviation in this regard shall be accepted.</p>	
12	<p><b>INSPECTION-</b> <b>Customer witness shall be applicable for all stages of manufacturing. Quantum of Customer Witness shall be decided during approval of Manufacturing QP.</b></p> <p><b>Inspection shall be as per BHEL &amp; Customer approved QAP.</b></p> <p><b>Inspection will be done by BHEL / Authorized agency (Bureau Veritas India Pvt Ltd / TUV SUD) &amp; Customer (wherever applicable as per Customer approved QAP).</b> Inspection charges of BHEL / Their representative are to BHEL A/c. Any other testing charges should be included in the quoted prices.</p> <p>Inspection requirements and documents / certification shall be as per CI 11 of 7488:TDG:001, Rev 00 dt 08.02.2022.</p> <ul style="list-style-type: none"><li>➤ All facilities, equipment and instruments required for inspection shall be provided by the contractor free of cost. BHEL's Representatives will have free access to contractor's works during the currency of the contract.</li><li>➤ BHEL shall have general supervision and direction over the work. BHEL has the authority to stop the work, whenever such stoppage may be necessary to ensure the proper execution of the contract. BHEL shall also have the authority to reject all the work which does not conform to the specification.</li></ul> <p>BHEL if required may test the finished sample per lot/size at NABL approved Lab at the bidder's cost.</p> <p><b>MDCC-</b> <b>MDCC from Customer shall be obtained upon completion of final inspection and this process shall be completed within 7 (SEVEN) days from the date of submission of MDCC request from the vendor along with supporting documents.</b></p>	
13	<p><b>QUALITY DOCUMENTS</b> One original + two copies of Quality Documents, as called for in the quality plan/Purchase order shall be sent to Purchase / Piping centre BHEL Chennai immediately after the shipment / despatch of Items. All the quality documents are to be submitted in soft copy (in CD format) apart from the hard copy.</p>	

**ANNEXURE-A**

**BID SPECIFIC ADDITIONAL TERMS & CONDITIONS FOR THE  
PROCUREMENT OF CARBON STEEL WELDED PIPES FOR KHURJA PROJECT**

14	<p><b><u>TERMS OF PAYMENT:</u></b> Payment terms shall be as per Clause “Payment Timelines” of the GeM bid.</p> <p>However preference in payment shall be given to MSE bidders as per MSMED Act 2006 subject to submission of relevant documents (100% payment within 45 days of issue of CRAC).</p> <p><b><u>No other payment terms will be accepted. If bidders propose for any other payment term other than indicated above, such bids will be rejected.</u></b></p> <p><b><u>PAYMENT DOCUMENTS -</u></b> Payment shall be made against presentation of following documents to Finance Department by Purchase department:</p> <ul style="list-style-type: none"><li>a) Tax Invoice in triplicate</li><li>b) Delivery Challan in triplicate whichever is applicable</li><li>c) Guarantee certificate</li><li>d) Lorry Way Bill &amp; E-way bill (Original + Two copies)</li><li>e) CRAC (Consignee Receipt &amp; Acceptance Certificate) in GeM</li><li>f) Quality documents (as per approved QP/PO)</li></ul> <p>Hence,</p> <ul style="list-style-type: none"><li>1. Soft copy of Invoice and LR should be sent immediately after dispatch by e-mail to Purchase.</li><li>2. Hard copy should be sent subsequently within 1 week.</li></ul> <p>Payment shall be processed only after receipt of CRAC in GeM.</p>												
15	<p><b><u>INTEGRITY PACT</u></b> – Format being sent (<b><u>Annexure-G</u></b>). Your bid will be considered only after signing and submitting the Integrity pact.</p> <p>a) IP is a tool to ensure that activities and transactions between the Company and its Bidders / Contractors are handled in a fair, transparent and corruption free manner. Following Independent External Monitors (IEMs) on the present panel have been appointed by BHEL with the approval of CVC to oversee implementation of IP in BHEL.</p> <table border="0" style="width: 100%;"><thead><tr><th style="text-align: left;">Sl No</th><th style="text-align: left;">IEM</th><th style="text-align: left;">Email</th></tr></thead><tbody><tr><td>1</td><td>Shri Arun Chandra Verma, IPS (Retd.)</td><td>acverma1@gmail.com</td></tr><tr><td>2</td><td>Shri Virendra Bahadur Singh, IPS (Retd.),</td><td>vbsinghips@gmail.com</td></tr></tbody></table> <p>b) The IP as enclosed with the tender is to be submitted (duly signed by authorized signatory) along with Techno-Commercial bid (Part-I, in case of two / three part bid). Only those bidders who have entered into such an IP with BHEL would be competent to participate in the bidding. In other words, entering into this Pact would be a preliminary qualification.</p> <p>c) Please refer Section-8 of IP for Role and Responsibilities of IEMs. In case of any complaint arising out of the tendering process, the matter may be referred to any of the above IEM(s). All correspondence with the IEMs shall be done through email only.</p> <p>Note: No routine correspondence shall be addressed to the IEM (phone / post / email) regarding the clarifications, time extensions or any other administrative queries, etc on the tender issued. All such clarification / issues shall be addressed directly to the tender issuing (procurement) department's officials whose contact details are provided below.</p> <table border="0" style="width: 100%;"><tbody><tr><td style="width: 50%;">Ms. Poongkodi.V Deputy Manager / Purchase Phone – 9488451450 Email: poongkodi@bhel.in</td><td style="width: 50%;">Mr. Venkataraman E DGM / Purchase Phone – 8754666021 Email: vram@bhel.in</td></tr></tbody></table>	Sl No	IEM	Email	1	Shri Arun Chandra Verma, IPS (Retd.)	acverma1@gmail.com	2	Shri Virendra Bahadur Singh, IPS (Retd.),	vbsinghips@gmail.com	Ms. Poongkodi.V Deputy Manager / Purchase Phone – 9488451450 Email: poongkodi@bhel.in	Mr. Venkataraman E DGM / Purchase Phone – 8754666021 Email: vram@bhel.in	
Sl No	IEM	Email											
1	Shri Arun Chandra Verma, IPS (Retd.)	acverma1@gmail.com											
2	Shri Virendra Bahadur Singh, IPS (Retd.),	vbsinghips@gmail.com											
Ms. Poongkodi.V Deputy Manager / Purchase Phone – 9488451450 Email: poongkodi@bhel.in	Mr. Venkataraman E DGM / Purchase Phone – 8754666021 Email: vram@bhel.in												
16	<p><b><u>CANCELLATION / TERMINATION OF CONTRACT, DEFAULT / BREACH OF CONTRACT AND RISK PURCHASE:</u></b> In case of abnormal delays (beyond the maximum late delivery period as per Penalty clause) in supplies / defective supplies or non-fulfilment of any other terms and conditions given in Purchase Order as enumerated subsequently in this clause, Purchaser shall be entitled to cancel the Order / Contract either in whole or portion thereof without</p>												

## ANNEXURE-A

### BID SPECIFIC ADDITIONAL TERMS & CONDITIONS FOR THE PROCUREMENT OF CARBON STEEL WELDED PIPES FOR KHURJA PROJECT

compensation to Seller / Contractor and if the Purchaser so desires, may procure upon such terms and in such manner as deemed appropriate, stores not so delivered or others of similar description where stores exactly complying with particulars are not, in the opinion of the Purchaser, which shall be final, readily procurable, at the risk and cost of the Seller / Contractor and the Seller / Contractor shall be liable to the Purchaser for any excess costs provided that the Seller / Contractor shall continue the performance of the Order / Contract to the extent not cancelled under the provisions of this clause. The Seller / Contractor shall on no account be entitled to any gain on such repurchases. If bidder does not agree to the above Risk Purchase Clause, BHEL reserves the right to reject the offer.

Risk & Cost Clause, in line with Conditions of Contract may be invoked in any of the following cases:

- i. Contractor / supplier's poor progress of the work vis-à-vis execution timeline as stipulated in the Contract, backlog attributable to contractor/ supplier including unexecuted portion of work / supply does not appear to be executable within balance available period (#) considering its performance of execution.
- ii. Withdrawal from or abandonment of the work by contractor before completion of the work as per contract.
- iii. Non completion of work / Non-supply by the Contractor / supplier within scheduled completion / delivery period as per Contract or as extended from time to time, for the reasons attributable to the contractor / supplier.
- iv. Termination of Contract on account of any other reason (s) attributable to Contractor / Supplier.
- v. Assignment, transfer, subletting of Contract without BHEL's written permission resulting in termination of Contract or part thereof by BHEL.
- vi. Non-compliance to any contractual condition or any other default attributable to Contractor / Supplier.

Risk and Cost amount against Balance Work:

Risk & Cost Amount= [(A-B) + (A x H/100)]

Where,

A= Value of Balance scope of Work / Supply (\*) as per rates of new contract

B= Value of Balance scope of Work / Supply (\*) as per rates of old contract being paid to the contractor / supplier at the time of termination of contract i.e. inclusive of PVC & ORC, if any.

H= Overhead Factor to be taken as 5

In case (A-B) is less than 0 (zero), value of (A-B) shall be taken as 0 (zero).

\*(Balance scope of work / supply)

Difference of Contract Quantities and Executed Quantities as on the date of issue of Letter for 'Termination of Contract', shall be taken as balance scope of Work / Supply for calculating risk & cost amount.

Contract quantities are the quantities as per original contract. If, Contract has been amended, quantities as per amended Contract shall be considered as Contract Quantities.

Items for which total quantities to be executed have exceeded the Contract Quantities based on drawings issued to contractor from time to time till issue of Termination letter, then for these items total Quantities as per issued drawings would be deemed to be contract quantities.

Substitute / extra items whose rates have already been approved would form part of contract quantities for this purpose. Substitute / extra items which have been executed but rates have not been approved, would also form part of contract quantities for this purpose and rates of such items shall be determined in line with contractual provisions.

However, increase in quantities on account of additional scope in new tender shall not be considered for this purpose. Note: In case portion of work is being withdrawn, contract quantities pertaining to portion of work withdrawn shall be considered as 'Balance scope of work / supply' for calculating Risk & Cost amount.

#### **LD against delay in executed work / supply in case of Termination of Contract in case of Risk and Cost Option**

LD against delay in executed work / supply shall be calculated in line with LD clause of the contract for the delay attributable to contractor / supplier. For limiting maximum LD value, contract value shall be taken as Executed Value of work / supply.

Method for calculation of "LD against delay in executed work / supply" is given below.

**ANNEXURE-A**

**BID SPECIFIC ADDITIONAL TERMS & CONDITIONS FOR THE  
PROCUREMENT OF CARBON STEEL WELDED PIPES FOR KHURJA PROJECT**

	<p>i. Let the time period from scheduled date of start of work till termination of contract excluding the period of Hold (if any) not attributable to contractor / supplier= T1</p> <p>ii. Let the value of executed work / supply till the time of termination of contract= X</p> <p>iii. Let the Total Executable Value of work / supply for which inputs / fronts were made available to contractor / supplier and were planned for execution till termination of contract= Y</p> <p>iv. Delay in executed work / supply attributable to contractor/supplier i.e. <math>T2 = (1 - X/Y) * T1</math></p> <p>v. LD shall be calculated in line with LD clause of the Contract for the delay attributable to contractor / supplier taking "X" as Contract Value and "T2" as delay attributable to contractor / supplier.</p> <p>Note: In case portion of work / supply is withdrawn, no LD shall be applicable for portion of work / supply withdrawn.</p> <p>Recovery from Supplier Recoveries from contractor / supplier on whom risk &amp; cost has been invoked shall be made from the following:</p> <p>i. Dues available in the form of Bills payable to contractor / supplier, SD, BG's against the same contract.</p> <p>ii. Dues payable to contractor / supplier against other contracts in the same Region / Unit / Division of BHEL.</p> <p>iii. Dues payable to contractor / supplier against other contracts in the different Region / Unit / division of BHEL.</p> <p>Legal Options for recovery of dues payable by the supplier / contractor.</p> <p><b>Bids deviating from the above BHEL's standard condition will be rejected.</b></p>	
17	<p><b><u>NON-DISCLOSURE AGREEMENT (NDA):</u></b> The bidders shall enter into the Non-disclosure agreement totally voluntarily, with full knowledge of its meaning and without duress. <b>(Format attached – as per Annexure-F).</b></p>	
18	<p><b><u>FRAUD PREVENTION POLICY:</u></b> The Bidder along with its associate/ collaborators/ sub-contractors/ sub-Bidders/ consultants/ service providers shall strictly adhere to BHEL Fraud Prevention Policy displayed on BHEL website <a href="http://www.bhel.com">http://www.bhel.com</a> and shall immediately bring to the notice of BHEL Management about any fraud or suspected fraud as soon as it comes to their notice.</p>	
19	<p><b><u>SUSPENSION OF BUSINESS DEALINGS WITH SUPPLIERS / CONTRACTORS:</u></b> The offers of the bidders who are under suspension as also the offers of the bidders, who engage the services of the banned firms /principal/agents, shall be rejected. The list of banned firms is available on BHEL web site <a href="http://www.bhel.com">www.bhel.com</a>.</p> <p><b>Integrity commitment, performance of the contract and punitive action thereof:</b></p> <p><b>Commitment by BHEL</b> BHEL commits to take all measures necessary to prevent corruption in connection with the tender process and execution of the contract. BHEL will during the tender process treat all Bidder(s) in a transparent and fair manner, and with equity.</p> <p><b>Commitment by Bidder/ Supplier/ Contractor</b></p> <ul style="list-style-type: none"><li>• The bidder/ supplier/ contractor commit to take all measures to prevent corruption and will not directly or indirectly influence any decision or benefit which he is not legally entitled to nor will act or omit in any manner which tantamount to an offence punishable under any provision of the Indian Penal Code, 1860 or any other law in force in India.</li><li>• The bidder/ supplier/ contractor will, when presenting his bid, disclose any and all payments he has made, and is committed to or intends to make to agents, brokers or any other intermediaries in connection with the award of the contract and shall adhere to relevant guidelines issued from time to time by Govt. of India/ BHEL.</li><li>• The bidder/ supplier/ contractor will perform/ execute the contract as per the contract terms &amp; conditions and will not default without any reasonable cause, which causes loss of business/ money/ reputation, to BHEL.</li></ul> <p>If any bidder/ supplier/ contractor during pre-tendering/ tendering/ post tendering/ award/ execution/ post execution stage indulges in any act, including but not limited to, mal-practices, cheating, bribery, fraud or and other misconduct or formation of cartel so as to influence the bidding process or influence the price or tampers the tendering process or acts or omits in any manner which tantamount to an offence punishable under any provision of the Indian Penal Code, 1860 or any other law in force in India, then, action may be taken against such bidder/ supplier/ contractor as per extant guidelines of the company available on <a href="http://www.bhel.com">www. bhel.com</a> and/or under applicable legal provisions. Guidelines for suspension of business dealings is available in the webpage: <a href="http://www.bhel.com/vender_registration/vender.php">http://www.bhel.com/vender_registration/vender.php</a>.</p>	

**ANNEXURE-A**

**BID SPECIFIC ADDITIONAL TERMS & CONDITIONS FOR THE  
PROCUREMENT OF CARBON STEEL WELDED PIPES FOR KHURJA PROJECT**

20	<p><b><u>PROHIBITED ACTS UNDER COMPETITION ACT, 2002:</u></b> All the bidders should desist from doing any acts prohibited under Chapter-II of the Competition Act, 2002. If any such instance is observed during this tender will attract disciplinary action as per BHEL policies.</p>	
21	<p><b><u>IN THE EVENT OF FORCE MAJEURE:</u></b></p> <p>a. Notwithstanding the provisions contained in other clauses, the supplier shall not be liable for imposition of any such sanction so long the delay and/or failure of the supplier in fulfilling its obligations under the contract is the result of an event of Force Majeure. For purposes of this clause, Force Majeure means an event beyond the control of the supplier and not involving the supplier's fault or negligence and which is not foreseeable and not brought about at the instance of the party claiming to be affected by such event and which has caused the non – performance or delay in performance. Such events may include, but are not restricted to, wars or revolutions, hostility, acts of public enemy, civil commotion, sabotage, fires, floods, explosions, epidemics, quarantine restrictions, strikes excluding by its employees, lockouts excluding by its management, freight embargoes and Acts of GOD.</p> <p>b. If a Force Majeure situation arises, the supplier shall promptly notify the Purchaser/Consignee in writing of such conditions and the cause thereof within twenty-one days of occurrence of such event. Unless otherwise directed by the Purchaser/Consignee in writing, the supplier shall continue to perform its obligations under the contract as far as reasonably practical, and shall seek all reasonable alternative means for performance not prevented by the Force Majeure event.</p> <p>c. If the performance in whole or in part or any obligation under this contract is prevented or delayed by any reason of Force Majeure for a period exceeding sixty days, either party may at its option terminate the contract without any financial repercussion on either side.</p> <p>In case due to a Force Majeure event the Purchaser/Consignee is unable to fulfil its contractual commitment and responsibility, the Purchaser/Consignee will notify the supplier accordingly and subsequent actions taken on similar lines described in above sub-paragraphs.</p>	
22	<p><b><u>LAWS GOVERNING THE CONTRACT:</u></b></p> <p>a. The contract shall be governed by the Laws of the Government of India in force.</p> <p>b. Irrespective of the place of execution of the contract, place of delivery, place of payment under the contract, the contract shall be deemed to have been made at the place at which the Acceptance of the tender has been issued.</p>	
23	<p><b><u>JURISDICTION OF THE COURT</u></b> The Courts of the place from where the acceptance of the tender has been issued shall alone have jurisdiction to decide any dispute arising out of or in respect of the contract.</p>	
24	<p><b><u>RESOLUTION OF DISPUTES:</u></b> The Parties agree that if at any time (whether before, during or after the arbitral or judicial proceedings), any Disputes (which term shall mean and include any dispute, difference, question or disagreement arising in connection with construction, meaning, operation, effect, interpretation or breach of the contract/tender which the Parties are unable to settle mutually), arise inter-se the Parties, the same may, be referred by either party to Conciliation to be conducted through Independent Experts Committee to be appointed by competent authority of BHEL from the BHEL Panel of Conciliators.</p> <p>The proceedings of Conciliation shall broadly be governed by Part-III of the Arbitration and Conciliation Act 1996 or any statutory modification thereof.</p> <p>Notes:</p> <p>1. No serving or a retired employee of BHEL/Administrative Ministry of BHEL shall be included in the BHEL Panel of Conciliators.</p> <p>2. Any other person(s) can be appointed as Conciliator(s) who is/are mutually agreeable to both the parties from outside the BHEL Panel of Conciliators.</p> <p>The proceedings of Conciliation shall broadly be governed by Part-III of the Arbitration and Conciliation Act 1996 or any statutory modification thereof.</p> <p>Except as provided elsewhere in this Contract, in case amicable settlement is not reached between the parties, in respect of any dispute or difference; arising out of the formation, breach, termination, validity or execution of the Contract; or, the respective rights and liabilities of the Parties; or, in relation to interpretation of any provision of the Contract ; or , in any manner touching upon the Contract, then, either Party may , by a notice in writing to other Party refer such dispute</p>	





**ANNEXURE-A**

**BID SPECIFIC ADDITIONAL TERMS & CONDITIONS FOR THE  
PROCUREMENT OF CARBON STEEL WELDED PIPES FOR KHURJA PROJECT**

	<p>or difference to sole arbitration of an arbitrator appointed as per the Arbitration and Conciliation Act, 1996 (India) or statutory modification or re-enactment thereof and the rules made thereunder and for the time being in force.</p> <p>The Arbitrator shall pass a reasoned award and the award of the Arbitrator shall be final and binding upon the parties. Subject as aforesaid, the provision of Arbitration &amp; Conciliation Act 1996 (India) or statutory modification or re-enactment thereof and the rules made thereunder and for the time being in force shall apply to the arbitration proceeding under this clause.</p> <p>The seat of arbitration shall be Chennai, Tamil Nadu, India. The cost of arbitration shall be borne as per the award of the Arbitrator. Subject to arbitration in terms of clause above, the Courts at Chennai, Tamil Nadu, India shall have exclusive jurisdiction over any matter arising out of or in connection with this Contract.</p> <p>Notwithstanding the existence or any dispute or difference and/or reference for the arbitration, the vendor shall proceed with and continue without hindrance the performance of its obligation under this Contract with due diligence and expedition in a professional manner except where the Contract has been terminated by either Party in terms of this Contract.</p> <p><b><u>In Case of Contract with Public Sector Enterprise (PSE) or a Government Department, the following shall be applicable:</u></b> In the event of any dispute or difference relating to the interpretation and application of the provisions of commercial contract(s) between Central Public Sector Enterprises (CPSEs)/Port Trusts inter se and also between CPSEs and Government Departments/Organizations (Excluding disputes concerning Railways, Income Tax, Customs &amp; Excise Departments, such dispute or difference shall be taken up by either party for resolution through AMRCD as mentioned in DPE OM No. 4(1)/2013 –DPE (GM)/FTS-1835 dated 22-05-2018.</p>	
25	<p><b><u>SET-OFF CLAUSE:</u></b> BHEL, Piping Centre, Chennai shall have the right to recover any money which in the sole opinion of BHEL is due from the Contractor from any money due to the Contractor like Payment of bills, payment of any amounts due, release of Security Deposit or return of Bank Guarantees furnished</p> <ul style="list-style-type: none"><li>a. Under this tender/contract <b>(OR)</b></li><li>b. Any other contract placed on the contractor by BHEL, Piping centre, Chennai <b>(OR)</b></li><li>c. Any other contract placed on the contractor by any Unit/s of BHEL</li></ul> <p>BHEL, Piping Centre, Chennai also reserves the right to set off the amount of the contractor available in any form, against any claims of any other contract with BHEL.</p>	
26	<p><b><u>CAUTION:</u></b></p> <p>a) The suppliers are severely cautioned to note that the price bid document accepts the price in figures only. It does not allow the supplier to write the value by words. Therefore, all care shall be exercised by the supplier while filling in the figures. Once the price bid is opened no option is available for the supplier to retract the offer under any grounds. If a supplier, for any reason whatsoever approaches BHEL with a request for change in the price, it would be treated as going back on the offer submitted. In such cases, action would be initiated by BHEL for suspending further business dealings with such suppliers as per policy of BHEL which prevails at that point of time.</p> <p>b) The language in the tender documents downloaded by the Bidders shall at no point of time be changed, altered or modified in any manner by the Tenderer. If such changes are made by any tenderer, it shall be considered as tampering with BHEL's terms and the offer shall be summarily rejected, whenever it is noticed by BHEL. Such Bidders would be disqualified from the Bidding Process and their offers would be forfeited / Bank Guarantees invoked. They would also not be allowed to participate in future tenders of BHEL.</p>	

**ANNEXURE-A**

**BID SPECIFIC ADDITIONAL TERMS & CONDITIONS FOR THE  
PROCUREMENT OF CARBON STEEL WELDED PIPES FOR KHURJA PROJECT**

27	<p><b><u>GENERAL:</u></b></p> <p>i. The PO copy with all details will be given to successful bidders in soft mode only.</p> <p>ii. Acknowledgement for receipt of PO shall be sent within one week from the date of receipt.</p> <p>iii. BHEL reserves the right to cancel this tender without assigning any reasons what so ever.</p> <p>iv. Deviation taken after placement of order will not be accepted (Both technical as well as on delivery).</p> <p>v. Suppliers to analyze in detail, at the time of submission of offer with reference to our “delivery” requirement of item and confirm compliance.</p> <p>vi. BHEL reserves the right to negotiate or re-float the tender opened, if L1 price / other details are not acceptable to them.</p> <p>vii. Any other terms or conditions mentioned in your offer other than the above mentioned formats will not be evaluated and will be considered null &amp; void. Hence your offer shall contain ONLY the above mentioned formats.</p> <p>viii. Bids not accepting to above conditions will be liable for rejection.</p> <p>ix. For verification of data submitted towards evaluation of bidder's capability, BHEL may decide to visit the bidder(s) works. Any fact found deviating from submitted data shall make the bidder liable to be disqualified.</p>	
28	<p><b><u>ENCLOSURES:</u></b></p> <div style="display: flex; justify-content: space-around; align-items: center;"><div style="text-align: center;"> Annexures to Bid Specific ATC.pdf</div><div style="text-align: center;"> Production Notes_3-80-468-369</div><div style="text-align: center;"> Edge Preparation drawing_4-80-468-8</div></div>	

CAUTION: The information on this document is the property of BHARAT HEAVY ELECTRICALS LTD. It must not be used directly or indirectly in any way detrimental to the interest of the company.

REV	DATE	ALTERED
		APPROVED

ALL DIMENSIONS ARE IN MILLIMETRES

NOTE: INSIDE BEVEL IS REQUIRED, ONLY IF D1 VALUE IS HIGHER THAN INSIDE DIAMETER.

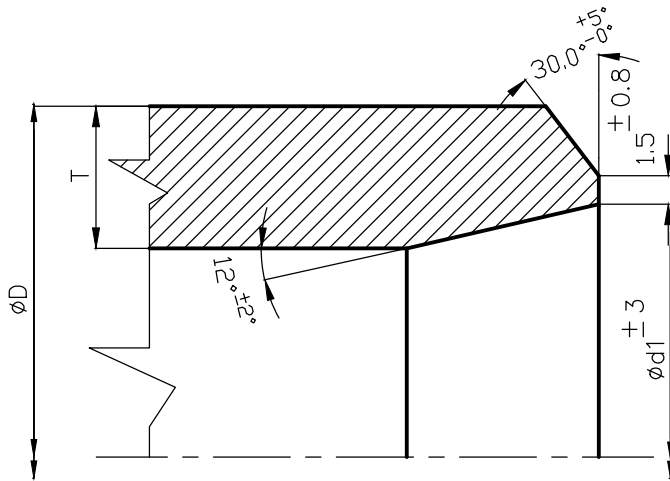

**STYLE-D**

PIPE SIZE	ød1
øD X T	D-2T

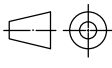
	<b>BHARAT HEAVY ELECTRICALS LIMITED</b> PIPING CENTRE CHENNAI 600 017		DRN	TRINADHA RAO	SIGN	DATE	NO. OF VAR	
			CHD	TRINADHA RAO		16.03.22		
			APPD	SARAVANAN.C		16.03.22		
DEPT	GRADE OF UNTOL. DIM		SCALE	WEIGHT (KG).	REF. TO ASSY./OLD DRG.		ITEM NO.	NO. OF ITEMS
CODE	C / M / F		N.T.S					
TITLE				CARD CODE	DRAWING NO.		REV	
<b>EDGE PREPARATION DETAIL</b>				U 01	<b>4-80-468-84546</b>		<b>00</b>	

DRAWING NO. 3-80-468-36924

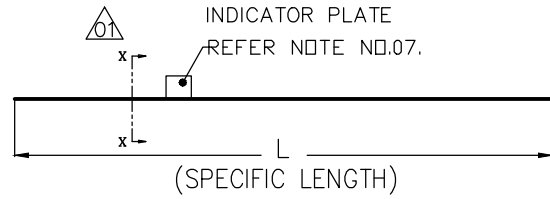

**NOTES: -**

- 01 ALL PIPES ARE TO BE SUPPLIED WITH EDGE PREPARATION AS PER DRG NO. 4-80-468-84546. FOR EP STYLE & WELD END DIA ( $\phi d1$ ), REFER THE TABLE. INSIDE BEVEL IS REQUIRED, ONLY IF D1 VALUE IS HIGHER THAN INSIDE DIAMETER.
- 02 TOLERANCE ON TOTAL LENGTH OF PIPE IS  $\pm 2$  METERS, IF TOTAL LENGTH IS  $>350M$ . OTHERWISE TOLERANCE ON TOTAL LENGTH OF PIPE IS  $\pm 0.5M$ .
- 03 FOR SHOP PAINTING/COATING DETAILS , REFER CUSTOMER APPROVED PAINTING SCHEDULE & QUALITY PLAN FOR THE PROJECT.
- 04 FOR PIPE DIAMETER  $> 1000mm$  , SPIDER ARRANGEMENT HAS TO BE PROVIDED AT THE ENDS AFTER EDGE PREPARATION , AS PER DRG. NO. 4-80-999-93078. FOR PIPE DIAMETER  $< 1000mm$  , SPIDER ARRANGEMENT IS NOT REQUIRED.
- 05 FOLLOW APPLICABLE TDG OF THE PROJECT.
- 06 PIPES SHALL BE OF CARBON STEEL (IS2062 Gr.E250 BR), ROLLED & WELDED CONFIRMING TO IS3589 Fe410MPa.
- 07 LUG PLATE (50X50X10THK) TO BE PROVIDED AT SUITABLE LOCATION ON OUTSIDE SURFACE OF PIPE AS PER DETAIL-P (WHEREVER APPLICABLE) TO IDENTIFY 100% RT PORTION OF PIPE DURING ERECTION.



SL. No.	DU NO.	PGMA	PIPE DESCRIPTION	QTY (in Meters)	SPECIFIC LENGTH	MATL. CODE	EDGE PREPARATION AS PER DRG NO. 4-80-468-84546		CUST NO.	SYSTEM DESCRIPTION
						MATL. SPEC.	STYLE	$\phi d1$		
01	001	80-468	PIPE OD3632x16 (UNDER GROUND PIPING)	1430	10 m TO 12 m	15 938 720 2001 IS2062 GR-E250 BR	STYLE-D	3600.0	7488	CW SYSTEM PIPING
02	002	80-468	PIPE OD2628x14 (UNDER GROUND PIPING)	820	10 m TO 12 m	15 938 721 2001 IS2062 GR-E250 BR	STYLE-D	2600.0	7488	CW SYSTEM PIPING

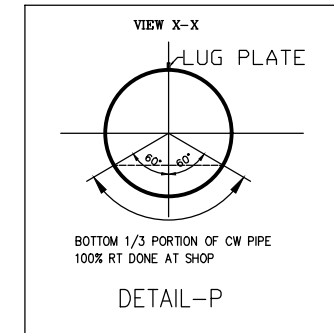

CUSTOMER NO. : 7488									
NAME OF PROJECT : KHURJA STPP 2x660MW									
NAME OF CUSTOMER : THDC INDIA LIMITED									
NAME OF CONSULTANT : NTPC LIMITED									
BHARAT HEAVY ELECTRICALS LTD., PIPING CENTRE, MADRAS	DRN	NAME	SIGN	DATE	NO OF ITEMS				
	CHD	TRINADHA RAO		02.02.22					
	APPD	TRINADHA RAO		02.02.22					
APPD	SARAVANAN		02.02.22						
REV 01	DATE 16.03.22	ALTERED APPROVED	TRINADHA RAO	DEPT.	GRADE OF UN TOL DIM	SCALE	WEIGHT (Kg).	NAME OF ORIGINAL ORGANISATION	ITEM No.
ZONE	NOTE NO.05 TO 07 ADDED. EP DRG MODIFIED. DETAIL-P ADDED. ALL REV MARKED AS		SARAVANAN		C/M/F	N.T.S			
TITLE							CARD CODE	DRAWING No.	REV
PRODUCTION NOTES FOR CW SYSTEM PIPING							U 01	3-80-468-36924	01

CAUTION: The information on this document is the property of BHARAT HEAVY ELECTRICALS LTD. It must not be used directly or indirectly in any way detrimental to the interest of the company