



Bid Number/बोली क्रमांक (बिड संख्या):
GEM/2023/B/3211994
Dated/दिनांक : 02-03-2023

Bid Document/ बिड दस्तावेज़

Bid Details/बिड विवरण	
Bid End Date/Time/बिड बंद होने की तारीख/समय	13-03-2023 16:00:00
Bid Opening Date/Time/बिड खुलने की तारीख/समय	13-03-2023 16:30:00
Bid Offer Validity (From End Date)/बिड पेशकश वैधता (बंद होने की तारीख से)	80 (Days)
Ministry/State Name/मंत्रालय/राज्य का नाम	Ministry Of Heavy Industries And Public Enterprises
Department Name/विभाग का नाम	Department Of Heavy Industry
Organisation Name/संगठन का नाम	Bharat Heavy Electricals Limited (bhel)
Office Name/कार्यालय का नाम	10250020-pem, Noida
Total Quantity/कुल मात्रा	61347
Item Category/मद केटेगरी	GS FLAT 25X3 MM , GS FLAT 35X 6 MM , GS FLAT 50 X 6 MM , GS FLAT 65 X 8 MM , GS ROD 20 MM DIA 1000MM LONG , TEST LINK 150 X 50 X 6 MM GS FLAT WITH BOX , FLEXIBLE COPPER BRAID FOR GATE EARTHING , GI WIRE 8 SWG , GI WIRE 16 SWG , 100 ID, 13 MM THICK CI PIPE PERFORATED 3 M LONG
BOQ Title/बीओक्यू शीर्षक	Above Ground Earthing Material for Panki Project
Years of Past Experience Required for same/similar service/उन्हीं/समान सेवाओं के लिए अपेक्षित विगत अनुभव के वर्ष	1 Year (s)
MSE Exemption for Years of Experience/अनुभव के वर्षों से एमएसई छूट/ and Turnover	No
Startup Exemption for Years of Experience/अनुभव के वर्षों से स्टार्टअप छूट/ and Turnover	No
Document required from seller/विक्रेता से मांगे गए दस्तावेज़	Experience Criteria,Past Performance,Additional Doc 1 (Requested in ATC),Compliance of BoQ specification and supporting document *In case any bidder is seeking exemption from Experience / Turnover Criteria, the supporting documents to prove his eligibility for exemption must be uploaded for evaluation by the buyer
Past Performance/विगत प्रदर्शन	10 %

Bid Details/बिड विवरण	
Bid to RA enabled/बिड से रिवर्स नीलामी सक्रिय किया	Yes
RA Qualification Rule	H1-Highest Priced Bid Elimination
Type of Bid/बिड का प्रकार	Two Packet Bid
Primary product category	GS FLAT 50 X 6 MM
Time allowed for Technical Clarifications during technical evaluation/तकनीकी मूल्यांकन के दौरान तकनीकी स्पष्टीकरण हेतु अनुमत समय	7 Days
Payment Timelines	Payments shall be made to the Seller within 90 days of issue of consignee receipt-cum-acceptance certificate (CRAC) and on-line submission of bills (This is in supersession of 10 days time as provided in clause 12 of GeM GTC)
Evaluation Method/मूल्यांकन पद्धति	Total value wise evaluation

EMD Detail/ईएमडी विवरण

Required	No
----------	----

ePBG Detail/ईपीबीजी विवरण

Advisory Bank	State Bank of India
ePBG Percentage(%) / ईपीबीजी प्रतिशत (%)	5.00
Duration of ePBG required (Months) / ईपीबीजी की अपेक्षित अवधि (महीने).	26

(a). EMD & Performance security should be in favour of Beneficiary, wherever it is applicable./ईएमडी और संपादन जमानत राशि, जहां यह लागू होती है, लाभार्थी के पक्ष में होनी चाहिए।

Beneficiary/लाभार्थी :

Branch CAG II New Delhi
10250020-PEM, Noida, Department of Heavy Industry, Bharat Heavy Electricals Limited (BHEL), Ministry of Heavy Industries and Public Enterprises
(A/c No. 39922687394 Ifsc Sbin0017313)

Splitting/विभाजन

Bid splitting not applied.

Reserved for Make In India products

Reserved for Make In India products	Yes
-------------------------------------	-----

MSE Purchase Preference/एमएसई खरीद वरीयता

1. Experience Criteria: In respect of the filter applied for experience criteria, the Bidder or its OEM {themselves or through reseller(s)} should have regularly, manufactured and supplied same or similar Category Products to any Central / State Govt Organization / PSU / Public Listed Company for number of Financial years as indicated above in the bid document before the bid opening date. Copies of relevant contracts to be submitted along with bid in support of having supplied some quantity during each of the Financial year. In case of bunch bids, the category of primary product having highest value should meet this criterion.

2. Bid reserved for Make In India products: : Procurement under this bid is reserved for purchase from Class 1 local supplier as defined in public procurement (Preference to Make in India), Order 2017 as amended from time to time and its subsequent Orders/Notifications issued by concerned Nodal Ministry for specific Goods/Products. However, eligible micro and small enterprises will be allowed to participate. The minimum local content to qualify as a class 1 local supplier is denoted in the bid document. All bidders must upload a certificate from the OEM regarding the percentage of the local content and the details of locations at which the local value addition is made along with their bid, failing which the bid is liable to be rejected. In case the bid value is more than Rs 10 Crore, the declaration relating to percentage of local content shall be certified by the statutory auditor or cost auditor, if the OEM is a company and by a practicing cost accountant or a chartered accountant for OEMs other than companies as per the Public Procurement (preference to Make-in -India) order 2017 dated 04.06.2020 . In case Buyer has selected Purchase preference to Micro and Small Enterprises clause in the bid, the same will get precedence over this clause.

3. Purchase preference to Micro and Small Enterprises (MSEs): Purchase preference will be given to MSEs as defined in Public Procurement Policy for Micro and Small Enterprises (MSEs) Order, 2012 dated 23.03.2012 issued by Ministry of Micro, Small and Medium Enterprises and its subsequent Orders/Notifications issued by concerned Ministry. If the bidder wants to avail the Purchase preference, the bidder must be the manufacturer of the offered product in case of bid for supply of goods. Traders are excluded from the purview of Public Procurement Policy for Micro and Small Enterprises. In respect of bid for Services, the bidder must be the Service provider of the offered Service. Relevant documentary evidence in this regard shall be uploaded along with the bid in respect of the offered product or service. If L-1 is not an MSE and MSE Seller (s) has/have quoted price within L-1+ 15% (Selected by Buyer) of margin of purchase preference /price band defined in relevant policy, such Seller shall be given opportunity to match L-1 price and contract will be awarded for 25%(selected by Buyer) percentage of total QUANTITY.

4. Estimated Bid Value indicated above is being declared solely for the purpose of guidance on EMD amount and for determining the Eligibility Criteria related to Turn Over, Past Performance and Project / Past Experience etc. This has no relevance or bearing on the price to be quoted by the bidders and is also not going to have any impact on bid participation. Also this is not going to be used as a criteria in determining reasonableness of quoted prices which would be determined by the buyer based on its own assessment of reasonableness and based on competitive prices received in Bid / RA process.

5. Past Performance: The Bidder or its OEM {themselves or through re-seller(s)} should have supplied same or similar Category Products for 10% of bid quantity, in at least one of the last three Financial years before the bid opening date to any Central / State Govt Organization / PSU / Public Listed Company. Copies of relevant contracts (proving supply of cumulative order quantity in any one financial year) to be submitted along with bid in support of quantity supplied in the relevant Financial year. In case of bunch bids, the category related to primary product having highest bid value should meet this criterion.

6. Reverse Auction would be conducted amongst all the technically qualified bidders except the Highest quoting bidder. The technically qualified Highest Quoting bidder will not be allowed to participate in RA. However, H-1 will also be allowed to participate in RA in following cases:

- i. If number of technically qualified bidders are only 2 or 3.
- ii. If Buyer has chosen to split the bid amongst N sellers, and H1 bid is coming within N.
- iii. In case Primary product of only one OEM is left in contention for participation in RA on elimination of H-1.
- iv. If L-1 is non-MSE and H-1 is eligible MSE and H-1 price is coming within price band of 15% of Non-MSE L-1
- v. If L-1 is non-MII and H-1 is eligible MII and H-1 price is coming within price band of 20% of Non-MII L-1

GS FLAT 25X3 MM

(Minimum 60% Local Content required for qualifying as Class 1 Local Supplier)

Brand Type/ब्रांड का प्रकार	Unbranded
-----------------------------	-----------

Technical Specifications/तकनीकी विशिष्टियाँ

Specification Document	View File
BOQ Detail Document	View File

Advisory-Please refer attached BOQ document for detailed consignee list and delivery period.

Consignees/Reporting Officer/परेषिती/रिपोर्टिंग अधिकारी and/ तथा Quantity/मात्र

S.No./क्र. सं.	Consignee Reporting/Officer/ परेषिती/रिपोर्टिंग अधिकारी	Address/पता	Quantity/मात्र	Delivery Days/डिलीवरी के दिन
1	Dinesh Kumar Vaishy	208020,Construction Manager, Bharat Heavy Electricals Limited c/o Chief Engineer (Projects), UPRVUNL PANKI TPS EXTENSION Panki , Dist. Kanpur (U.P) Pin-208020 (Uttar Prades)h	1	999

GS FLAT 35X 6 MM

(Minimum 60% Local Content required for qualifying as Class 1 Local Supplier)

Brand Type/ब्रांड का प्रकार	Unbranded
-----------------------------	-----------

Technical Specifications/तकनीकी विशिष्टियाँ

Specification Document	View File
BOQ Detail Document	View File

Advisory-Please refer attached BOQ document for detailed consignee list and delivery period.

Consignees/Reporting Officer/परेषिती/रिपोर्टिंग अधिकारी and/ तथा Quantity/मात्र

S.No./क्र. सं.	Consignee Reporting/Officer/ परेषिती/रिपोर्टिंग अधिकारी	Address/पता	Quantity/मात्र	Delivery Days/डिलीवरी के दिन
1	Dinesh Kumar Vaishy	208020,Construction Manager, Bharat Heavy Electricals Limited c/o Chief Engineer (Projects), UPRVUNL PANKI TPS EXTENSION Panki , Dist. Kanpur (U.P) Pin-208020 (Uttar Prades)h	1	999

GS FLAT 50 X 6 MM**(Minimum 60% Local Content required for qualifying as Class 1 Local Supplier)**

Brand Type/ब्रांड का प्रकार	Unbranded
-----------------------------	-----------

Technical Specifications/तकनीकी विशिष्टियाँ

Specification Document	View File
BOQ Detail Document	View File

Advisory-Please refer attached BOQ document for detailed consignee list and delivery period.

Consignees/Reporting Officer/परेषिती/रिपोर्टिंग अधिकारी and/ तथा Quantity/मात्र

S.No./क्र. सं.	Consignee Reporting/Officer/ परेषिती/रिपोर्टिंग अधिकारी	Address/पता	Quantity/मात्र	Delivery Days/डिलीवरी के दिन
1	Dinesh Kumar Vaishy	208020,Construction Manager, Bharat Heavy Electricals Limited c/o Chief Engineer (Projects), UPRVUNL PANKI TPS EXTENSION Panki , Dist. Kanpur (U.P) Pin-208020 (Uttar Prades)h	40	999

GS FLAT 65 X 8 MM

(Minimum 60% Local Content required for qualifying as Class 1 Local Supplier)

Brand Type/ब्रांड का प्रकार	Unbranded
-----------------------------	-----------

Technical Specifications/तकनीकी विशिष्टियाँ

Specification Document	View File
BOQ Detail Document	View File

Advisory-Please refer attached BOQ document for detailed consignee list and delivery period.

Consignees/Reporting Officer/परेषिती/रिपोर्टिंग अधिकारी and/ तथा Quantity/मात्रा

S.No./क्र. सं.	Consignee Reporting/Officer/ परेषिती/रिपोर्टिंग अधिकारी	Address/पता	Quantity/मात्रा	Delivery Days/डिलीवरी के दिन
1	Dinesh Kumar Vaishy	208020,Construction Manager, Bharat Heavy Electricals Limited c/o Chief Engineer (Projects), UPRVUNL PANKI TPS EXTENSION Panki , Dist. Kanpur (U.P) Pin-208020 (Uttar Prades)h	2	999

GS ROD 20 MM DIA 1000MM LONG

(Minimum 60% Local Content required for qualifying as Class 1 Local Supplier)

Brand Type/ब्रांड का प्रकार	Unbranded
-----------------------------	-----------

Technical Specifications/तकनीकी विशिष्टियाँ

Specification Document	View File
BOQ Detail Document	View File

Advisory-Please refer attached BOQ document for detailed consignee list and delivery period.

Consignees/Reporting Officer/परेषिती/रिपोर्टिंग अधिकारी and/ तथा Quantity/मात्र

S.No./क्र. सं.	Consignee Reporting/Officer/ परेषिती/रिपोर्टिंग अधिकारी	Address/पता	Quantity/मात्र	Delivery Days/डिलीवरी के दिन
1	Dinesh Kumar Vaishy	208020,Construction Manager, Bharat Heavy Electricals Limited c/o Chief Engineer (Projects), UPRVUNL PANKI TPS EXTENSION Panki , Dist. Kanpur (U.P) Pin-208020 (Uttar Prades)h	81	999

TEST LINK 150 X 50 X 6 MM GS FLAT WITH BOX**(Minimum 60% Local Content required for qualifying as Class 1 Local Supplier)**

Brand Type/ब्रांड का प्रकार	Unbranded
-----------------------------	-----------

Technical Specifications/तकनीकी विशिष्टियाँ

Specification Document	View File
BOQ Detail Document	View File

Advisory-Please refer attached BOQ document for detailed consignee list and delivery period.

Consignees/Reporting Officer/परेषिती/रिपोर्टिंग अधिकारी and/ तथा Quantity/मात्र

S.No./क्र. सं.	Consignee Reporting/Officer/ परेषिती/रिपोर्टिंग अधिकारी	Address/पता	Quantity/मात्र	Delivery Days/डिलीवरी के दिन
1	Dinesh Kumar Vaishy	208020,Construction Manager, Bharat Heavy Electricals Limited c/o Chief Engineer (Projects), UPRVUNL PANKI TPS EXTENSION Panki , Dist. Kanpur (U.P) Pin-208020 (Uttar Prades)h	81	999

FLEXIBLE COPPER BRAID FOR GATE EARTHING

(Minimum 60% Local Content required for qualifying as Class 1 Local Supplier)

Brand Type/ब्रांड का प्रकार	Unbranded
-----------------------------	-----------

Technical Specifications/तकनीकी विशिष्टियाँ

Specification Document	View File
BOQ Detail Document	View File

Advisory-Please refer attached BOQ document for detailed consignee list and delivery period.

Consignees/Reporting Officer/परेषिती/रिपोर्टिंग अधिकारी and/ तथा Quantity/मात्रा

S.No./क्र. सं.	Consignee Reporting/Officer/ परेषिती/रिपोर्टिंग अधिकारी	Address/पता	Quantity/मात्रा	Delivery Days/डिलीवरी के दिन
1	Dinesh Kumar Vaishy	208020,Construction Manager, Bharat Heavy Electricals Limited c/o Chief Engineer (Projects), UPRVUNL PANKI TPS EXTENSION Panki , Dist. Kanpur (U.P) Pin-208020 (Uttar Prades)h	5	999

GI WIRE 8 SWG

(Minimum 60% Local Content required for qualifying as Class 1 Local Supplier)

Brand Type/ब्रांड का प्रकार	Unbranded
-----------------------------	-----------

Technical Specifications/तकनीकी विशिष्टियाँ

Specification Document	View File
BOQ Detail Document	View File

Advisory-Please refer attached BOQ document for detailed consignee list and delivery period.

Consignees/Reporting Officer/परेषिती/रिपोर्टिंग अधिकारी and/ तथा Quantity/मात्र

S.No./क्र. सं.	Consignee Reporting/Officer/ परेषिती/रिपोर्टिंग अधिकारी	Address/पता	Quantity/मात्र	Delivery Days/डिलीवरी के दिन
1	Dinesh Kumar Vaishy	208020,Construction Manager, Bharat Heavy Electricals Limited c/o Chief Engineer (Projects), UPRVUNL PANKI TPS EXTENSION Panki , Dist. Kanpur (U.P) Pin-208020 (Uttar Prades)h	1100	999

GI WIRE 16 SWG**(Minimum 60% Local Content required for qualifying as Class 1 Local Supplier)**

Brand Type/ब्रांड का प्रकार	Unbranded
-----------------------------	-----------

Technical Specifications/तकनीकी विशिष्टियाँ

Specification Document	View File
BOQ Detail Document	View File

Advisory-Please refer attached BOQ document for detailed consignee list and delivery period.

Consignees/Reporting Officer/परेषिती/रिपोर्टिंग अधिकारी and/ तथा Quantity/मात्र

S.No./क्र. सं.	Consignee Reporting/Officer/ परेषिती/रिपोर्टिंग अधिकारी	Address/पता	Quantity/मात्र	Delivery Days/डिलीवरी के दिन
1	Dinesh Kumar Vaishy	208020,Construction Manager, Bharat Heavy Electricals Limited c/o Chief Engineer (Projects), UPRVUNL PANKI TPS EXTENSION Panki , Dist. Kanpur (U.P) Pin-208020 (Uttar Prades)h	60000	999

100 ID, 13 MM THICK CI PIPE PERFORATED 3 M LONG

(Minimum 60% Local Content required for qualifying as Class 1 Local Supplier)

Brand Type/ब्रांड का प्रकार	Unbranded
-----------------------------	-----------

Technical Specifications/तकनीकी विशिष्टियाँ

Specification Document	View File
BOQ Detail Document	View File

Advisory-Please refer attached BOQ document for detailed consignee list and delivery period.

Consignees/Reporting Officer/परेषिती/रिपोर्टिंग अधिकारी and/ तथा Quantity/मात्रा

S.No./क्र. सं.	Consignee Reporting/Officer/ परेषिती/रिपोर्टिंग अधिकारी	Address/पता	Quantity/मात्रा	Delivery Days/डिलीवरी के दिन
1	Dinesh Kumar Vaishy	208020,Construction Manager, Bharat Heavy Electricals Limited c/o Chief Engineer (Projects), UPRVUNL PANKI TPS EXTENSION Panki , Dist. Kanpur (U.P) Pin-208020 (Uttar Prades)h	36	999

Buyer Added Bid Specific Terms and Conditions/क्रेता द्वारा जोड़ी गई बिड की विशेष शर्तें

1. Generic

OPTION CLAUSE: The Purchaser reserves the right to increase or decrease the quantity to be ordered up to 25 percent of bid quantity at the time of placement of contract. The purchaser also reserves the right to increase the ordered quantity by up to 25% of the contracted quantity during the currency of the contract at the contracted rates. Bidders are bound to accept the orders accordingly.

2. Inspection

Nominated Inspection Agency: On behalf of the Buyer organization, any one of the following Inspection Agency would be conducting inspection of stores before acceptance:

Pre-dispatch Inspection at Seller Premises (applicable only if pre-dispatch inspection clause has been selected in ATC):

At vendor's works

Post Receipt Inspection at consignee site before acceptance of stores:
NA

3. **Buyer Added Bid Specific ATC**

Buyer uploaded ATC document [Click here to view the file.](#)

4. **Generic**

Bidders are advised to check applicable GST on their own before quoting. Buyer will not take any responsibility in this regards. GST reimbursement will be as per actuals or as per applicable rates (whichever is lower), subject to the maximum of quoted GST %.

5. **Generic**

Data Sheet of the product(s) offered in the bid, are to be uploaded along with the bid documents. Buyers can match and verify the Data Sheet with the product specifications offered. In case of any unexplained mismatch of technical parameters, the bid is liable for rejection.

6. **Generic**

Supplier shall ensure that the Invoice is raised in the name of Consignee with GSTIN of Consignee only.

7. **Generic**

While generating invoice in GeM portal, the seller must upload scanned copy of GST invoice and the screenshot of GST portal confirming payment of GST.

Disclaimer/अस्वीकरण

The additional terms and conditions have been incorporated by the Buyer after approval of the Competent Authority in Buyer Organization, whereby Buyer organization is solely responsible for the impact of these clauses on the bidding process, its outcome, and consequences thereof including any eccentricity / restriction arising in the bidding process due to these ATCs and due to modification of technical specifications and / or terms and conditions governing the bid. Any clause(s) incorporated by the Buyer regarding following shall be treated as null and void and would not be considered as part of bid:-

1. Definition of Class I and Class II suppliers in the bid not in line with the extant Order / Office Memorandum issued by DPIIT in this regard.
2. Seeking EMD submission from bidder(s), including via Additional Terms & Conditions, in contravention to exemption provided to such sellers under GeM GTC.
3. Publishing Custom / BOQ bids for items for which regular GeM categories are available without any Category item bunched with it.
4. Creating BoQ bid for single item.
5. Mentioning specific Brand or Make or Model or Manufacturer or Dealer name.
6. Mandating submission of documents in physical form as a pre-requisite to qualify bidders.
7. Floating / creation of work contracts as Custom Bids in Services.
8. Seeking sample with bid or approval of samples during bid evaluation process.
9. Mandating foreign / international certifications even in case of existence of Indian Standards without specifying equivalent Indian Certification / standards.
10. Seeking experience from specific organization / department / institute only or from foreign / export experience.
11. Creating bid for items from irrelevant categories.
12. Incorporating any clause against the MSME policy and Preference to Make in India Policy.
13. Reference of conditions published on any external site or reference to external documents/clauses.
14. Asking for any Tender fee / Bid Participation fee / Auction fee in case of Bids / Forward Auction, as the case may be.

Further, if any seller has any objection/grievance against these additional clauses or otherwise on any aspect of this bid, they can raise their representation against the same by using the Representation window provided in the bid details field in Seller dashboard after logging in as a seller within 4 days of bid publication on GeM. Buyer is duty bound to reply to all such representations and would not be allowed to open bids if he fails to reply to such representations.

[This Bid is also governed by the General Terms and Conditions/ यह बिड सामान्य शर्तों के अंतर्गत भी शासित है](#)

In terms of GeM GTC clause 26 regarding Restrictions on procurement from a bidder of a country which shares a land border with India, any bidder from a country which shares a land border with India will be eligible to bid in this tender only if the bidder is registered with the Competent Authority. While participating in bid, Bidder has to undertake compliance of this and any false declaration and non-compliance of this would be a ground for immediate termination of the contract and further legal action in accordance with the laws./जेम की सामान्य शर्तों के खंड 26 के संदर्भ में भारत के साथ भूमि सीमा साझा करने वाले देश के बिडर से खरीद पर प्रतिबंध के संबंध में भारत के साथ भूमि सीमा साझा करने वाले देश का कोई भी बिडर इस निविदा में बिड देने के लिए तभी पात्र होगा जब वह बिड देने वाला सक्षम प्राधिकारी के पास पंजीकृत हो।बिड में भाग लेते समय बिडर को इसका अनुपालन करना होगा और कोई भी गलत घोषणा किए जाने व इसका अनुपालन न करने पर अनुबंध को तत्काल समाप्त करने और कानून के अनुसार आगे की कानूनी कार्रवाई का आधार होगा।

---Thank You/धन्यवाद---

Index of Annexures

GeM Tender Enquiry for Above Ground Earthing Material for 1x 660 MW Panki Project

Sl. No.	Description	Annexures
1.	Additional terms and conditions (ATC)	Annexure I
2.	BOQ	Annexure II
3.	Delivery Schedule	Annexure III
4.	Land border certificate	Annexure IV
5.	Certificate for local Content	Annexure V
6.	Technical PQR	-
7.	Technical Specification	-
8.	Price Variation Clause (PVC)	Annexure B (part of technical specification)

ANNEXURE –I (Above Ground Earthing Material)

Additional Terms and Conditions (ATC)

Additional Terms and Conditions for subject Tender Enquiry to be complied by Bidders for Consideration in this tender:

1. Dispatch Markings: -

Each box shall be marked with Capital Letters in “Red” indicating the PEM supply (Main Supply/ Commissioning spare/ Mandatory Spare) for 1x 660 MW Panki Thermal Power Station Project. Each package delivered under the Contract shall be marked by Supplier and such marking must be distinct and in English Language (all previous irrelevant markings being carefully obliterated). Such marking shall show the description and quantity of contents, the name and address of consignee, the Gross weight and Net weight of the package, the name of the Supplier, PEM P.O. reference number, with a distinctive number of mark sufficient for purposes of identification. Besides above necessary, packing shall bear a special marking `TOP`, `BOTTOM`, `DO NOT TURN OVER`, “KEEP DRY”, “HANDLE WITH CARE”, etc.

IMPORTANT

- Two copies of respective standard manufacturer’s erection instruction/operation instruction manual shall be kept in each package / container for immediate reference by BHEL site and same shall be reflected in packing slip also
- The Packing list details for the consignment must be put inside the Box/Boxes.

Commissioning Spares: - The commissioning spares shall be properly packed separately in separate box and each spare shall be properly tagged giving details i.e. dispatch (to match the description given in the packing slip) to facilitate their proper identification. One Copy of Packing list must be put inside the Box.

Note:- Main Supply items and items for comm. spares must be packed separately.

2. Liquidated Damages: -

a) **Main Supply:-** Purchaser reserves the right to recover from the Seller/ Contractor, as agreed liquidated damages and not by way of penalty, a sum equivalent to half (½) percent and applicable GST thereon, of the total main supply & commissioning spares contract price excluding GST per week or part thereof, subject to a maximum of ten(10) percent of the total main supply & commissioning Spares contract price excluding GST, if the Seller/ Contractor fails to deliver any part of the ordered goods/stores within the period stipulated in the Order/ Contract.

NOTE:

i. LR/RR date for indigenous supplies (Bill of Lading/AWB for Foreign supplies) shall be treated as the date of dispatch for levying LD. However, if receipted LR date for indigenous supply is beyond 30 days for FTL/ 45 days for PTL from the date of LR (PTL to be clearly mentioned in LR), such excess period shall be considered for LD purpose irrespective of dispatch date. Import General Manifest (IGM)/Bill of entry date (whichever is earlier), for foreign supplies, is beyond 90 days from the date of Bill of Lading/AWB, such excess period shall be considered for LD purpose irrespective of dispatch date.

ii. In case of any amendment/ revision, LD shall be linked to the amended/ revised contract value and delivery date(s).

ANNEXURE –I (Above Ground Earthing Material)

Additional Terms and Conditions (ATC)

iii. If Order/ Contract involves two or more Units/ Sets/ Lots/ Stages, then Liquidated Damages shall be levied on order/ contract value excluding GST of the delayed Unit/ Set/ Lot/ Stage, provided delivery stipulated in the Order/ Contract is Unit/ Set/ Lot/Stage wise, however total LD amount shall be limited to 10% of total order/ amended order value excluding GST of delayed Unit/ Set/ Lot/Stage. Any subsequent lot released (not envisaged in original contract) due to increase in quantity within permissible quantity variation shall be treated as separate lot for the purpose of LD.

iv. The sum specified above is not a penalty but a genuine pre-estimate of the loss/ damage which will be suffered by purchaser on account of delay on the part of the Contractor/Seller and the said amount will be deductible without proof of actual loss or damage caused by such delay.

3. Risk & Cost Purchase

BHEL reserves the right to terminate the contract or withdraw portion of work and get it done through other agency, at the risk and cost of the contractor after due notice of a period of 14 days' by BHEL in any of the following cases:

i) If the Seller/Contractor fails to deliver the goods or materials or any instalment thereof within the period(s) fixed for such delivery or the Seller's poor progress of the supply/ services vis-à-vis delivery/execution timeline as stipulated in the Contract, backlog attributable to seller including unexecuted portion of supply does not appear to be executable within balance available period;

ii) Delivers goods or materials not of the contracted quality and failing to adhere to the contract specifications;

iii) Withdrawal from or repudiation/ abandonment of the supply/ services by Seller before completion as per contract or if the Seller refuses or is unable to supply goods or materials covered by the Order/Contract either in whole or in part or otherwise fails to perform the Order/Contract;

iv) Non-supply by the Seller within scheduled completion/delivery period as per Contract or as extended from time to time, for the reasons attributable to the Seller;

v) Termination of Contract on account of any other reason (s) attributable to Seller.

vi) Assignment, transfer, subletting of Contract without BHEL's written permission resulting in termination of Contract or part thereof by BHEL.

vii) If the Seller be an individual or a sole proprietorship Firm, in the event of the death or insanity of the Seller;

viii) If the Seller/Contractor being an individual or if a firm on a partnership thereof, shall at any time, be adjudged insolvent or shall have a receiving order for administration of his estate made against him or shall take any proceeding for composition under any Insolvency Act for the time being in force or make any assignment of the Order/Contract or enter into any arrangement or composition with his creditors or suspend payment or if the firm dissolved under the Partnership Act;

ix) If the Seller/Contractor being a company is wound up voluntarily or by order of a Court or a Receiver, Liquidator or Manager on behalf of the debenture holders and creditors is appointed or circumstances

ANNEXURE –I (Above Ground Earthing Material)

Additional Terms and Conditions (ATC)

shall have arisen which entitles the Court of debenture holder and creditors to appoint a receiver, liquidator or manager;

x) Non-compliance to any contractual condition or any other default attributable to Seller.

Such defaulting vendor/Seller shall not be eligible to participate in re-tendering conducted on account of risk purchase made due to fault of such vendor/Seller.

3.1 Risk & Cost Amount against Balance Work:

Risk & Cost amount against balance work shall be calculated as follows:

$$\text{Risk \& Cost Amount} = [(A-B) + (A \times H/100)]$$

Where,

A= Value of Balance scope of Work (*) as per rates of new contract

B= Value of Balance scope of Work (*) as per rates of old contract being paid to the contractor at the time of termination of contract i.e. inclusive of PVC & ORC, if any.

H = Overhead Factor to be taken as 5

In case (A-B) is less than 0 (zero), value of (A-B) shall be taken as 0 (zero).

3.2 * Balance scope of work (in case of termination of contract):

Difference of Contract Quantities and Executed Quantities as on the date of issue of Letter for 'Termination of Contract', shall be taken as balance scope of Work for calculating risk & cost amount.

Contract quantities are the quantities as per original contract. If, Contract has been amended, quantities as per amended Contract shall be considered as Contract Quantities.

Items for which total quantities to be executed have exceeded the Contract Quantities based on drawings issued to contractor from time to time till issue of Termination letter, then for these items total Quantities as per issued drawings would be deemed to be contract quantities.

Substitute/ extra items whose rates have already been approved would form part of contract quantities for this purpose.

Substitute/ extra items which have been executed but rates have not been approved, would also form part of contract quantities for this purpose and rates of such items shall be determined in line with contractual provisions.

However, increase in quantities on account of additional scope in new tender shall not be considered for this purpose.

NOTE: In case portion of work is being withdrawn at risk & cost of contractor instead of termination of contract, contract

quantities pertaining to portion of work withdrawn shall be considered as 'Balance scope of work' for calculating Risk & Cost amount.

ANNEXURE –I (Above Ground Earthing Material)

Additional Terms and Conditions (ATC)

3.3 LD against delay in executed work in case of Termination of Contract:

LD against delay in executed work shall be calculated in line with above LD clause, for the delay attributable to contractor. For limiting the maximum value of LD, contract value shall be taken as Executed Value of work till termination of contract.

Method for calculation of LD against delay in executed work in case of termination of contract” is given below.

i. Let the time period from scheduled date of start of work till termination of contract excluding the period of

Hold (if any) not attributable to contractor = T1

ii. Let the value of executed work till the time of termination of contract = X

iii. Let the Total Executable Value of work for which inputs/fronts were made available to contractor and were

planned for execution till termination of contract = Y

iv. Delay in executed work attributable to contractor i.e. T2 = $[1-(X/Y)] \times T1$

v. LD shall be calculated in line with LD clause (clause 16) of the Contract for the delay attributable to contractor taking “X” as Contract Value and “T2” as period of delay attributable to contractor.

3.4 Recoveries arising out of Risk & Cost and LD or any other recoveries due from Contractor

Without prejudice to the other means of recovery of such dues from the Seller recoveries from the Seller on whom risk & cost has been invoked shall be made from the following:

a) Dues available in the form of Bills payable to seller, SD, BGs against the same contract.

b) Dues payable to seller against other contracts in the same Region/Unit/ Division of BHEL.

c) Dues payable to seller against other contracts in the different Region/Unit/ division of BHEL.

In-case recoveries are not possible with any of the above available options, Legal action shall be initiated for recovery against contractor.

4. For recognition of dispatch, vendor to submit following documents to BHEL by e-mail/ fax immediately on dispatch: - GST compliant invoice, LR (indicating Invoice No., no. of boxes, PTL (if applicable) etc.), Packing List (Must be indicating No. of boxes, Packing size, Gross weight and net weight of each package, Contents of the package with cross reference to BoM item code no. or item serial no. and Quantity of each item separately), Insurance Intimation to underwriter through email/fax, Dispatch Clearance.

B. Following ATC available in GEM shall also be made part of NIT: -

i. Bidder's offer is liable to be rejected if they don't upload any of the certificates / documents sought in the Bid document, ATC and Corrigendum if any.

ANNEXURE –I (Above Ground Earthing Material)

Additional Terms and Conditions (ATC)

- ii.** Bidders are advised to check applicable GST on their own before quoting. Buyer will not take any responsibility in this regards. GST reimbursement will be as per actuals or as per applicable rates (whichever is lower), subject to the maximum of quoted GST %.
- iii.** Data Sheet of the product(s) offered in the bid, are to be uploaded along with the bid documents. Buyers can match and verify the Data Sheet with the product specifications offered. In case of any unexplained mismatch of technical parameters, the bid is liable for rejection.
- iv.** The bidder is required to upload, along with the bid, all relevant certificates such as BIS license, type test certificate, approval certificates and other certificates as prescribed in the Product Specification given in the bid document.
- v.** While generating invoice in GeM portal, the seller must upload scanned copy of GST invoice and the screenshot of GST portal confirming payment of GST.

ANNEXURE –I (Above Ground Earthing Material)

Additional Terms and Conditions (ATC)

Additional Terms and Conditions for subject Tender Enquiry to be complied by bidders for consideration in this tender:

- A. Bidders to ensure that Third party/Customer issued certificates being submitted as proof of PQR qualification should have verifiable details of document/certificate issuing authority such as name & designation of Issuing Authority and its organization contact number and E-mail Id. In case the same is found not available, BHEL has the right to reject such document from evaluation.
- B. "This item /package/system falls under the list of items defined in para 3 of ministry of finance guideline date 20.09.16 (procurement of items related to public safety, health, critical security operations and Equipment's etc.) & hence criteria of prior experience /turnover shall be same for all bidders including start up /MSME".
- C. **Guarantee & Warrantee** shall be as per Cl. No. 10 of GTC on GeM for the bid. However, Guarantee & Warrantee time period shall be 18 months from the date of last supply in the contract.
- D. Evaluation shall be on the basis of total all inclusive, landed price at consignee destination (Refer Cl. No. 6 of GTC on GEM).
- E. **Terms of Delivery:** FOR Dispatch Station Basis. However, Transit insurance shall be in the scope of seller and unloading of items (at delivery point) shall be in buyer scope. Further, w.r.t. Transit Insurance supplier has to inform the details of dispatches (such as Policy No., Consignee Name, Consignment Packing details, Project Name, Purchase Order No., LR No. & date, Invoice No. & date, Dispatch Origin & destination details etc.) to policy underwriter under intimation to BHEL.
- F. PQR criteria uploaded with Buyer uploaded Bid Specific document shall prevail value of Experience criteria and Past performance parameter mentioned in GeM bid.
- G. "Due to COVID-19 pandemic condition prevailing in the country BHEL/PEM may go for Remote Inspection of Offered items if required. Vendors are requested to be equipped with the facilities/gadgets as indicated in the guidelines available at : <https://pem.bhel.com/Documents/VendorSection/Vendor/Guidelines.pdf> to take up the inspection remotely.
- H. **Inspection call to be raised by bidder on BHEL CQIR portal** (details shall be shared at the of execution of order) and Inspection agency shall attend at the inspection within seven (07) days of the date on which the material is notified as being ready. In case of delay in witnessing of inspection beyond stipulated time (i.e. 7 days from the date on which the material is notified as being ready), by BHEL arising due to reasons not attributable to vendor, BHEL will extend the delivery period for such delay in carrying out inspection. If BHEL is not able to witness inspection up to 15 days then in addition to delay beyond stipulated period, extension in delivery time of 07 days for arranging fresh inspection will be given.

When the tests have been satisfactorily completed at Seller/ Contractor's works, the Inspection Agency shall issue an inspection report that effect within seven (07) days after completion of the tests, but if the tests were not witnessed by the Inspection Agency or his representative, the material acceptance report would be issued within seven (07) days after receipt of the test certificates by the Purchaser.

Purchaser will issue MDCC to the Seller/ Contractor within 7 days based on inspection report/ test certificates/Certificate of Conformance as applicable. In case of delay in issuance of MDCC beyond 7 days stipulated time (i.e. from the date of successful inspection report), by BHEL arising due to reasons not attributable to vendor, BHEL will extend the delivery period for such delay in issuing

ANNEXURE –I (Above Ground Earthing Material)

Additional Terms and Conditions (ATC)

MDCC. If BHEL is not able to issue MDCC up to 15 days then in addition to delay beyond stipulated period, 7 days' additional time shall be given to vendor to facilitate the vendor for arranging logistics arrangements.

- I. All Bidders shall be required to submit applicable Freight % & GST % included in their prices during clarification stage of Tender.
- J. Performance Bank Guarantee: shall be as per Cl. No. 7 of GTC of GeM. Performance Security amount shall be @5% of the value of contract value.
- K. **Payment Terms:** As per clause no. 12 (i) of GTC on GeM. Payments shall be made to the Seller within 90 days (45 days for seller qualified and registered as Micro or small and 60 days for Medium enterprises as per MSMED Act.) of issue of consignee receipt-cum-acceptance certificate (CRAC) and on-line submission of bills (This is in supersession of 10 days' time as provided in clause 12 of GeM GTC).

Supplier has to provide Original Tax Invoice + 1 copy of Tax invoice, Packing List, LR/RR or AWB, CRAC, Insurance intimation, Guarantee Certificate, E-way bill (as applicable) for payment.

Further bidder to submit the final documents (Final drgs & Inspection document) in 12 no.s of hard copies and 04 no.s of CD along with Invoice.

Provision of offline payment in GeM shall be utilized.

- L. **Bid reserved for Make in India products:** - Procurement under this bid is reserved for purchase from Class 1 local suppliers as defined in public procurement (Preference to Make in India), Order 2017 as amended from time to time and its subsequent Orders/Notifications issued by concerned Nodal Ministry for specific Goods/Products. The minimum local content to qualify as a class 1 local supplier is denoted in the bid document as 60%. All bidders must upload a certificate from the OEM regarding the percentage of the local content and the details of locations at which the local value addition is made along with their bid, failing which the bid is liable to be rejected.

Regarding verification of local content, the local supplier at the time of tender, bidding or solicitation shall be required to provide certification (as per enclosed **Annexure-V**) as per para 9 of PP-MII order revision dated 16.09.2020.

- M. **This is conditional tender enquiry. Financial bid opening (Part-II) of a bidder shall be subjected to following:** -

- (i) Techno-Commercial evaluation/recommendation by BHEL.
- (ii) Qualification of Technical PQR
- (iii) Offered item should mandatorily conform to PP-MII order provisions.

- N. **Consignee Details** (for PRC - Provisional Receipt Certificate & CRAC - Consignee's Receipt cum Acceptance Certificate, as applicable) shall be as per Project Site official details.

- O. The Bidder has to declares that they will not enter into any illegal or undisclosed agreement or understanding, whether formal or informal with other Bidder(s). This applies in particular to prices, specifications, certifications, subsidiary contracts, submission or non-submission of bids or any other actions to restrict competitiveness or to introduce cartelization in the bidding process. In case, the bidder is found having indulged in above activities, suitable action shall be taken by BHEL as per extant policies/guidelines.

- P. **Bidders to ensure the following:** -

- Ensure compliance to Ministry of Power (MoP) Order No. 11/05/2018-Coord. dt. 28/07/2020, if applicable.

ANNEXURE –I (Above Ground Earthing Material)

Additional Terms and Conditions (ATC)

- Ensure compliance of Ministry of Finance (MoF) Order (Public Procurement No. 1 & 2) F. No. 6/18/2019/PPD dt. 23/07/2020.
 - to submit “Model Certificate for Tenders” as per **Annexure-IV** of Ministry of Finance (MoF) Order (Public Procurement No. 1 & 2) F. No. 6/18/2019/PPD dt. 23/07/2020, 08/02/21, 06/09/22 & 23/02/23. Bidder to submit the following undertaking on their letter head duly signed from the highest competent authority at your end (i.e Owner, partner, CMD, Director etc.)
- Q. Delivery Period:** As per attached Annexure-III. Delivery period for sake of GeM bid shall be chosen as 999 days from PO date. However, this period shall not be considered for Delivery and Delay analysis purpose.
- R.** For registration in BHEL PEM- Online registration portal is operational, Non-registered Vendors who wish to apply for registration in BHEL-PEM can apply through Online Registration Portal available at www.pem.bhel.com - vendor section - Online Supplier Registration. All credentials and/or documents duly signed and stamped related to registration can be uploaded on the website and submit the application for registration. However, registration of suppliers is not mandatory in case of open tender.
- S.** Quantity Variation clause of +/- 25% of GeM ATC shall be utilized using option clause.
- T.** CIF is not applicable for subject tender.
- U.** PVC is applicable for Flats and Wires as per Annexure B to Tech. Specification. For the rest of the items of the BOQ except GS Flats and GS wires, unit price shall remain firm for entire contract. Price variation shall be limited to +20% of total Exworks prices actually supplied and no limit on -ve price variation with base month of February 2023 for the items where PVC is applicable. PVC shall be payable only for contractual delivery period (including delivery extensions if any) i.e no PVC shall be payable for delay in delivery attributed to vendor & in delayed delivery cases, PVC for contractual delivery date & actual delivery date shall be compared and whichever is found lower side shall be payable to vendor.
- V.** Integrity pact not applicable.
- W.** MSE Preference: - Being subject package is divisible and MSE preference (maximum 25%) shall be given. Purchase preference to Micro and Small Enterprises (MSEs): Purchase preference will be given to MSEs as defined in Public Procurement Policy for Micro and Small Enterprises (MSEs) Order, 2012 dated 23.03.2012 issued by Ministry of Micro, Small and Medium Enterprises and its subsequent Orders/Notifications issued by concerned Ministry. If the bidder wants to avail the Purchase preference, the bidder must be the manufacturer of the offered product in case of bid for supply of goods. Traders are excluded from the purview of Public Procurement Policy for Micro and Small Enterprises. In respect of bid for Services, the bidder must be the Service provider of the offered Service. Relevant documentary evidence in this regard shall be uploaded along with the bid in respect of the offered product or service. If L-1 is not an MSE and MSE Seller (s) has/have quoted price within L 1 + 15% of margin of purchase preference /price band defined in relevant policy, such Seller(s) shall be given opportunity to match L-1 price and contract will be awarded for 25% percentage of total quantity.
- a) If L1 bidder is MSE bidder, entire quantity will be given to such MSE bidder only.
- b) In case of more than one such MSE, within the price band of L1 +15%, the supply shall be shared proportionately, provided the available quantum can be split.

ANNEXURE –I (Above Ground Earthing Material)

Additional Terms and Conditions (ATC)

X. Bidder to note the following: -

A bidder shall not have conflict of interest with other bidders. Such conflict of interest can lead to anti-competitive practices to the detriment of Procuring Entity's interests. The bidder found to have a conflict of interest shall be disqualified. A bidder may be considered to have a conflict of interest with one or more parties in this bidding process, if:

- they have controlling partner (s) in common;' or
- they receive or have received any direct or indirect subsidy/ financial stake from any of them; or
- they have the same legal representative/agent for purposes of this bid; or
- they have relationship with each other, directly or through common third parties, that puts them in a position to have access to information about or influence on the bid of another Bidder; or
- Bidder participates in more than one bid in this bidding process. Participation by a Bidder in more than one Bid will result in the disqualification of all bids in which the parties are involved. However, this does not limit the inclusion of the components/ sub-assembly/ Assemblies from one bidding manufacturer in more than one bid, or
- In cases of agents quoting in offshore procurements, on behalf of their principal manufacturers, one agent cannot represent two manufacturers or quote on their behalf in a particular tender enquiry. One manufacturer can also authorize only one agent/dealer. There can be only one bid from the following:
 1. The principal manufacturer directly or through one Indian agent on his behalf; and
 2. Indian/foreign agent on behalf of only one principal,'or
- A Bidder or any of its affiliates participated as a consultant in the preparation of the design or technical specifications of the contract that is the subject of the Bid, or
- In case of a holding company having more than one independently manufacturing units, or more than one unit having common business ownership/management, only one unit should quote. Similar restrictions would apply to closely related sister companies. Bidders must proactively declare such sister/ common business/ management units in same/ similar line of business. "

Y. All other terms & conditions shall be as per GeM bid, selected Additional Terms & Conditions from GeM library and GTC on GeM 4.0 (version 1.18) available on GeM Portal on enquiry floating date shall be applicable.



1 X 660 MW PANKI PROJECT

ANNEXURE -II TO BOQ CUM PRICE SCHEDULE FOR ABOVE GROUND EARTHING AND LIGHTNING PROTECTION MATERIAL

SL NO	Item Code	ITEM DESCRIPTION	UOM	TOTAL QTY
1	507-23014-A	GS FLAT 25X3 MM	MT	1
2	507-23016-A	GS FLAT 35X 6 MM	MT	1
3	507-23017-A	GS FLAT 50 X 6 MM	MT	40
4	507-23020-A	GS FLAT 65 X 8 MM	MT	2
5	507-23023-A	GS ROD 20 MM DIA 1000MM LONG	NOS	81
6	507-23030-A	TEST LINK 150 X 50 X 6 MM GS FLAT WITH BOX	NOS	81
7	507-23008-A	FLEXIBLE COPPER BRAID FOR GATE EARTHING	NOS	5
8	507-23013-A	GI WIRE 8 SWG	MTR	1100
9	507-23011-A	GI WIRE 16 SWG	MTR	60000
10	507-23001-A	100 ID, 13 MM THICK CI PIPE PERFORATED 3 M LONG	NOS	36
11		TOTAL LUMPSUM PRICE (1 to 10)		

Annexure III to Delivery Schedule

Sl. No.	Package Code	Package name	DEPTT	BHEL Drawing No	Drawing Title	Primary/Secondary	BHEL Inputs	Drg Sch for Vendors	Standard Delivery Terms for Supply Portion
1	507-23000-A	ABOVE GROUND EARTHING MATERIAL	ELECT	PE-V0-426-507-E903	Standard Quality Plan	Primary		R-0 within 14 days from PO & subsequent revisions within 10 days of comments received from BHEL. BHEL shall furnish comments / approval on each submission within 18 days from receipt.	For Lot-1: Within Four (04) months from date of CAT-1 approval of Primary drawing/documents or BHEL manufacturing clearance whichever is later subjected to drawing/document submission/re-submission schedule as stipulated, in case of any delay in submission/re-submission of Primary drawing/documents, then same shall be reduced from the given delivery period. For Subsequent Lots: Within 3 months from Lot clearance by BHEL.

Notes:-

- (i) The end period specified is for completion of the deliveries. Deliveries to start progressively so as to meet the completion schedule.
- (ii) The delivery conditions specified are for contractual LD purposes, however BHEL may ask for early deliveries without any compensation thereof.
- (iii) Non-applicable drawings shall be decided during bid evaluation of the package.
- (iv) Wherever schedule of drawings/documents submission / re-submission is stipulated in the Technical Specifications, same shall be superseded by delivery specified in NIT.
- (v) Vendor to start manufacturing activities only after obtaining specific manufacturing clearance from BHEL Purchase group.
- (vi) In case BHEL manufacturing clearance date is later than the date of Cat-1 approval of Primary drawing/documents, then the contractual delivery period will be calculated by setting off the time gap between Cat-1 approval date of Primary drawing/documents and the manufacturing clearance date, from any delay by vendor in submission/re-submission of Primary drawing/documents
- (vii) In case -ve qty. variation not utilised till PO placement, Lot- I qty. shall be treated as PO qty.

Annexure IV

An undertaking regarding Model Clauses on company letter head only

(To be provided along with bid)

Reference: NIT No.-

Package: - Above Ground Earthing Material

Project: 1x 660 MW Panki TPS

TO WHOM SO IT MAY CONCERN

This is with reference to Ministry of Finance circular dated 23.07.20, 08.02.21,06.09.22 & 23.02.23 reg. restriction under rule 144 (xi) of GFR.

"I have read the clause regarding restrictions on procurement from a bidder of a country which shares a land border with India. I hereby certify that M/s (bidder name) is not from such a country and is eligible to be considered/participate in tender enquiry for against aforesaid tender enquiry.

Sign & Signature (Not below Director/owner of the company)

Date:

Place:

ANNEXURE V
1x 660 MW Panki TPS
Above Ground Earthing Material
Letter head of Company

Ref.....

Date.....

To,
Bharat Heavy Electricals Limited
PEM, PPEI Building, Plot No 25,
Sector -16A, Noida (U.P) -201301

Subject: - Certification regarding local content

Reference: Tender Enquiry No.....

Name of Package: Above Ground Earthing Material

Dear Sir,

We hereby certify that items offered by us of Above Ground Earthing Material for 1x 660 MW Panki TPS(minimum % of local content) meets the requirement of minimum local content in line with applicable clause of Make In India and the Public Procurement (Preference to Make in India), Order 2017 dated-15.06.2017, 28.05.2018 & 29.05.2019, 04.06.20, 16.09.20 and subsequent order dated 16.11.21.

We further confirm that details of location at which the local value addition is made will be our registered works at(address of the works)

Yours very truly

..... (authorized signatory of company)

..... (firm name)

authorized signatory
of company

	1X660 MW PANKI TPS PRE-QUALIFICATION REQUIREMENTS FOR ABOVE GROUND EARTHING MATERIALS	PE-PQ-426-509-E002
		REVISION NO. 0 DATE 08.02.2023
		SHEET NO. 1 OF 1



ITEMS: GS flats, GS rods, perforated pipe,

SCOPE: Supply: YES; Erection & Commissioning: NO;

1	Supplied GS flats/GS rods/perforated pipe.
2	Vendor should have capability of supplying galvanized flats / channels/angles/structure of 25 MT per month.
3	Vendor has his own galvanization plant. Vendor to furnish details of galvanizing process zinc bath details, type of furnace, details of temperature monitoring, details of ETP etc. OR Vendor should get galvanization of earthing material from any of BHEL-PEM approved galvanizers.
4	Supplied at least 40 MT of galvanized flats/channels/angles/structure in one or more orders and at least 25 MT in a single order.
5	Minimum two (2) nos. purchase orders for galvanized flats/channels/angles/structure shall be submitted which should not be more than five (5) years old from the date of techno-commercial bid opening for establishing continuity in business.

Notes (General points of PQR):

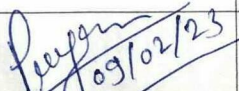
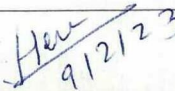
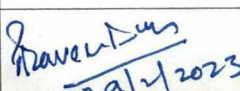
1. Consideration of offer shall be subject to customer's approval of bidders, if applicable
2. Bidder to submit all supporting documents in English. If documents submitted by bidder are in language other than English, a self- attested English translated document should also be submitted.
3. Notwithstanding anything stated above, BHEL reserves the right to assess the capabilities and capacity of the bidder to perform the contract, should the circumstances warrant such assessment in the overall interest of BHEL.
4. After satisfactory fulfilment of the above criteria/ requirement, offer shall be considered for further evaluation as per NIT and all the other terms of tender.

PARTICULARS	PREPARED BY	REVIEWED BY	CHECKED BY	APPROVED BY
SIGNATURE & DATE:	 09/02/23	 9/2/23	 29/2/2023	 09/2/23
NAME:	PRIYANKA GUPTA	HEMA KUSHWAHA	PRAVEEN DUTTA	DEBASISA RATH
DESIGNATION	MGR	SR. MGR.	ADDL GEN MGR	ADDL GEN MGR (DH-ELECTRICAL)

1X660 MW UPRVUNL PANKI TPS

TECHNICAL SPECIFICATION

FOR

***ABOVE GROUND EARTHING
&
LIGHTNING PROTECTION MATERIALS***

SPECIFICATION NO.: *PE - TS - 426 - 509 - E003*

REVISION: 00



**BHARAT HEAVY ELECTRICALS LIMITED
POWER SECTOR
PROJECT ENGINEERING MANAGEMENT
NOIDA, UP (INDIA) – 201301**

	TECHNICAL SPECIFICATION FOR ABOVE GROUND EARTHING & LIGHTNING PROTECTION MATERIALS	SPECIFICATION NO. PE-TS-426-509-E003
		VOLUME NO.: II-B
		SECTION: I
		REV NO.: 00 DATE: 02.02.2023
		SHEET : 1 OF 1

CONTENTS

S. NO	DESCRIPTION	NO. OF SHEETS
1	COMPLIANCE SHEET	01
2	SECTION - 'I' (SCOPE OF ENQUIRY)	02
3	SECTION - 'II' (STANDARD TECHNICAL REQUIREMENTS)	03
	ANNEXURE – A (APPLICABLE STANDARDS & CODES)	01
	TECHNICAL DATA SHEET	02
	(QUALITY PLAN) + ANNEXURE 1	04
4	DRAWINGS	
	TYPICAL DETAILS OF TEST LINK WITH PROTECTIVE BOX	01
	TYPICAL DETAILS OF FLEXIBLE BRAIDED COPPER CONDUCTOR, 20MM DIA GS ROD & PERFORATED PIPE	01
5	ANNEXURE-B (PRICE VARIATION FORMULAE)	01

	TECHNICAL SPECIFICATION FOR ABOVE GROUND EARTHING & LIGHTNING PROTECTION MATERIALS	SPECIFICATION NO. PE-TS-426-509-E003
		VOLUME NO.: II-B
		SECTION: I
		REV NO.: 00 DATE: 02.02.2023
		SHEET : 1 OF 1

COMPLIANCE CERTIFICATE

The bidder shall confirm compliance to the following by signing/ stamping this compliance certificate and furnishing same with the offer.

1. The scope of supply, technical details, construction features, design parameters etc. shall be as per technical specification & there are no exclusion/ deviation with regard to same
2. There are no deviations with respect to specification other than those furnished in the 'schedule of deviations'
3. Only those technical submittals which are specifically asked for in NIT to be submitted at tender stage shall be considered as part of offer. Any other submission, even if made, shall not be considered as part of offer.
4. Any comments/ clarifications on technical/ inspection requirements furnished as part of bidder's covering letter shall not be considered by BHEL, and bidder's offer shall be construed to be in conformance with the specification.
5. Any changes made by the bidder in the price schedule with respect to the description/ quantities from those given in 'BOQ-Cum-Price schedule' of the specification shall not be considered (i.e., technical description & quantities as per the specification shall prevail).
6. Price variation formulae provided on Sheet 20 of 20 of this specification.

BIDDER'S STAMP & SIGNATURE

1315293/2023/PS-PEM-EL



**TECHNICAL SPECIFICATION FOR
ABOVE GROUND EARTHING &
LIGHTNING PROTECTION MATERIALS**

SPECIFICATION NO. PE-TS-426-509-E003

VOLUME NO.: II-B

SECTION: I

REV NO.: 00 DATE: 02.02.2023

SHEET : 1 OF 1

**SECTION – I
SPECIFIC TECHNICAL REQUIREMENTS**

	TECHNICAL SPECIFICATION FOR ABOVE GROUND EARTHING & LIGHTNING PROTECTION MATERIALS	SPECIFICATION NO. PE-TS-426-509-E003
		VOLUME NO.: II-B
		SECTION: I
		REV NO.: 00 DATE: 02.02.2023
SHEET : 1 OF 1		

SCOPE OF ENQUIRY

1. SCOPE OF ENQUIRY

- 1.1. Design, Manufacture, Inspection and Testing at Manufacturer's works, proper packing and delivery to site of Above Ground Earthing & Lightning Protection Material conforming to this specification.
- 1.2. General technical requirements of the Above Ground Earthing & Lightning Protection Material are indicated in Section-II . Project specific technical/ quality requirements / changes are listed in Section-I.
- 1.3. The stipulations of Technical Data Sheet shall prevail in case of any conflict between the stipulations of Technical Data Sheet & Section-II.
- 1.4. The documents shall be in English Language and MKS system of units.

2. BILL OF QUANTITIES:

The bidder to quote for items as per price schedule attached with NIT.

3. DRAWINGS & DOCUMENTS TO BE SUBMITTED

- 3.1 Documents shall be submitted after placement of order for BHEL & customer's approval as specified in NIT.
- 3.2 Documents shall be furnished through BHEL's document management system(wrench) portal.

Notes:

- Vendor shall submit the drawing/document submission/resubmission schedule after approval of documents.

	TECHNICAL SPECIFICATION FOR ABOVE GROUND EARTHING & LIGHTNING PROTECTION MATERIALS	SPECIFICATION NO. PE-TS-426-509-E003
		VOLUME NO.: II-B
		SECTION: I
		REV NO.: 00 DATE: 02.02.2023
		SHEET : 1 OF 1

STANDARD TECHNICAL REQUIREMENTS

1.0 INTENT OF SPECIFICATION

- 1.1 This specification covers the design, manufacture, inspection & testing, packing at manufacturer's works and delivery to site of **Above Ground Earthing & Lightning Protection materials**.
- 1.2 The intent of specification is not to specify all details of design & construction of material. The material shall, however, conform in all aspects to high standard of design, engineering and workmanship and be capable of performing in continuous operation up to & after bidder's guarantee period in manner acceptable to purchaser who will interpret the drawings & specification and shall have power to reject any work or material which in his judgement is not in full accordance with this specification.

2.0 CODES AND STANDARDS

- 2.1 The material shall comply with all currently applicable safety codes and statutory regulations of India as well as of the locality where the material is to be installed.
- 2.2 The design, material, construction, manufacture, inspection, testing and performance of **Above Ground Earthing & Lightning Protection materials** shall conform to the latest revision of relevant standards and codes of practices as per Annexure-A.
- 2.3 **In case of conflict between the applicable reference standard and this specification, this specification shall govern.**

3.0 SCOPE OF ENQUIRY

- 3.1 Bidder shall quote for **Above Ground Earthing & Lightning Protection materials** in accordance with various sections of this specification. The system shall be complete in all aspects, for satisfactory operation, in accordance with this specification & technical particular.

4.0 TECHNICAL REQUIREMENTS

- 4.1 Technical particulars of Above Ground Earthing & Lightning Protection materials are specified in Technical Datasheet.
- 4.2 Straight lengths of hot dip galvanised MS materials as per project specific requirement shall be supplied in standard lengths as below:
- a) MS Flats of all sizes : 4-7 metres
- b) SWG wires of different sizes : 100 metres (minimum)

	TECHNICAL SPECIFICATION FOR ABOVE GROUND EARTHING & LIGHTNING PROTECTION MATERIALS	SPECIFICATION NO. PE-TS-426-509-E003
		VOLUME NO.: II-B
		SECTION: I
		REV NO.: 00 DATE: 02.02.2023
		SHEET : 1 OF 1

- 4.3 All finished galvanized MS material shall be free from sharp edges, corners, burs & unevenness.
- 4.4 Test link with box shall be as per enclosed drawing no. PE-DG-426-509-E003.
- 4.5 Flexible braided Copper Conductor of 600 mm length (cross section equivalent to 300 sq.mm) with tinned copper clamp connected by U-bolt for fence gate earthing shall be as per enclosed drawing no. PE-DG-426-509-E003.
- 4.6 Necessary fixing hardware shall be provided along with each accessory as specified in drawings enclosed.

5.0 QUALITY ASSURANCE, TESTING & INSPECTION

- 5.1 BHEL's Standard QP (PE-QP-999-509-E001) enclosed forms the minimum requirement but not limited to be adhered by the bidder. After issuance of purchase order for specific project, the successful bidder shall submit the QP for BHEL/ end customer's approval. In case bidder has reference QP agreed with end customer, same can be submitted for specific project after issuance of purchase order for BHEL/ end customer's approval. There shall be no commercial implication to BHEL on account of QP approval. Inspection shall be carried out in line with QP approved for specific project.
- 5.2 All materials shall be procured, manufactured, inspected and tested by vendor/ sub-vendor as per quality plan approved for specific project.
- 5.3 The supplier shall perform all tests necessary to ensure that the material and workmanship conform to the relevant standards and comply with the requirements of the specification. Charges for all these tests for all the equipment & components shall be deemed to be included in the bid price.

6.0 PACKING

- 6.1 The material shall be packed to ensure protection against damage during transit, storage for prolonged periods and handling.

7.0 DRAWINGS & DOCUMENTS TO BE SUBMITTED

- 7.1 Bidders shall furnish following documents as the part of their technical offer for 'Rate Contract': -
- Complete signed & stamped copy of this specification.
 - "No Technical Deviation" certificate w.r.t. this specification.
 - Unpriced 'Price Schedule' after mentioning "Quoted" against the items quoted.
- 7.2 After rate contract, after issuance of purchase order against specific project requirement following information shall be furnished by BHEL: -
- Title Sheet
 - Updated list of BHEL-PEM approved Galvanizers (Refer Annexure-2 to Quality Plan)

	TECHNICAL SPECIFICATION FOR ABOVE GROUND EARTHING & LIGHTNING PROTECTION MATERIALS	SPECIFICATION NO. PE-TS-426-509-E003
		VOLUME NO.: II-B
		SECTION: I
		REV NO.: 00 DATE: 02.02.2023
		SHEET : 1 OF 1

7.3 Following documents/drawings shall be submitted after placement of order for BHEL/customer's approval: -

Sl. No.	Drawings/Document Description	Drawings / Document Number
1.	QUALITY PLAN FOR ABOVE GROUND EARTHING & LIGHTNING PROTECTION MATERIAL.	PE-V1-426-509-E903
2	TECHNICAL DATA SHEET FOR ABOVE GROUND EARTHING & LIGHTNING PROTECTION MATERIALS	PE-V1-426-509-E002
3	GA DRAWINGS FOR ABOVE GROUND EARTHING & LIGHTNING PROTECTION MATERIALS	PE-V1-426-509-E003

7.4 Document indicated at clause no. 7.3 above, shall be submitted through document management system (DMS).

	TECHNICAL SPECIFICATION FOR ABOVE GROUND EARTHING & LIGHTNING PROTECTION MATERIALS	SPECIFICATION NO. PE-TS-426-509-E003
		VOLUME NO.: II-B
		SECTION: I
		REV NO.: 00 DATE: 02.02.2023
SHEET : 1 OF 1		

ANNEXURE - A

APPLICABLE STANDARDS & CODES

For Hot rolled carbon sheets & strips.	IS: 2062
For Mild Steel Wire	IS: 280
For Surface pre treatment	IS: 2629
For Hot dip galvanising of steel	IS: 2629
For Hot dipped galvanised coating on round steel wires	IS: 4826
For Testing of zinc coating	IS: 2633
For Determining of mass of zinc coating	IS: 6745
For Rolling & cutting tolerances of hot rolled steel products	IS: 1852
For Hot dip zinc coating on structural steel & other allied products	IS: 4759
For Tubes, Tubulars and other Wrought Steel Fittings	IS: 1239

	TECHNICAL SPECIFICATION FOR ABOVE GROUND EARTHING & LIGHTNING PROTECTION MATERIALS	SPECIFICATION NO. PE-TS-426-509-E003
		VOLUME NO.: II-B
		SECTION: I
		REV NO.: 00 DATE: 02.02.2023
		SHEET : 1 OF 1

TECHNICAL DATASHEET

1.0 GALVANIZED MS MATERIALS FOR ABOVE GROUND EARTHING AND LIGHTNING PROTECTION SYSTEMS

- a) Material: Hot Rolled Mild Steel
- b) Type: Hot-dip galvanized

3.0 SURFACE TREATMENT

Galvanising:

- a) Pre-treatment As per IS 2629 prior to galvanization
- b) Type Hot dip galvanization.
- c) Applicable Standard IS 2629
- d) Minimum thickness:

- | | |
|--|----------------------------|
| i) MS flats 5mm thick & over | 75 microns (minimum) |
| ii) MS flats under 5mm thickness | 60 microns (minimum) |
| iii) Pipes/ conduits with thickness 5 mm & over. | 75 microns (minimum) |
| iv) Pipes/ conduits with thickness under 5mm | 60 microns (minimum) |
| v) GI Wire | 20 Microns (Medium coated) |

e) Min. weight:

- | | |
|--|---------------------|
| i) MS flats 5mm thick & over | 610 gms. / sq. mtr. |
| ii) MS flats under 5mm thickness | 460 gms. / sq. mtr. |
| iii) Pipes/ conduits with thickness 5 mm & over. | 610 gms. / sq. mtr |
| iv) Pipes/ conduits with thickness under 5mm. | 460 gms. / sq. mtr |
| v) GI Wire | 150 gms. / sq. mtr. |



**TECHNICAL SPECIFICATION FOR
ABOVE GROUND EARTHING &
LIGHTNING PROTECTION MATERIALS**

SPECIFICATION NO. PE-TS-426-509-E003

VOLUME NO.: II-B

SECTION: I

REV NO.: 00 DATE: 02.02.2023

SHEET : 1 OF 1

f) Thickness of Pipes:

Sl. No.	Material	Size	Thickness (in mm.)
1	Cast Iron (CI)	100 ID	13.0
2	Mild Steel (MS)	25 NB, Heavy duty	4.0
3	Mild Steel (MS)	40 NB, Heavy duty	4.0
4	Mild Steel (MS)	50 NB, Heavy duty	4.5
5	Mild Steel (MS)	65 NB, Heavy duty	4.5
6	Mild Steel (MS)	100 NB, Heavy duty	5.4

		STANDARD QUALITY PLAN											
		MANUFACTURER/ BIDDER/ SUPPLIER NAME & ADDRESS					CUSTOMER :					SPEC. NO :	DATE: 02.11.2020
		PROJECT:					PO NO.:					QP NO.: PE-QP-999-509-E001, R2.	
		ITEM: ABOVE GROUND EARTHING MATERIALS					SYSTEM: EARTHING					SECTION: II	SHEET 1 OF 5
Sl. No.	COMPONENT S & OPERATIONS	CHARACTERISTICS	CLASS	TYPE OF CHECK	QUANTUM OF CHECK	REFERENCE DOCUMENT	ACCEPTANCE NORMS	FORMAT OF RECORD	AGENCY			REMARKS	
1	2	3	4	5	M 6 C/N	7	8	9	D	M	C	N	

1.0	RAW MATERIAL:												
1.1	MILD STEEL (FLATS & RODS) AS PER SPECIFICATION	1. CHEMICAL & PHYSICAL PROPERTIES 2. DIMENSIONS 3. SURFACE FINISH	MA	VERIFICATION OF TCS	100%	IS 2062	IS 2062	MILL TC	✓	P	V	-	REFER REMARKS AT SL. NO. 3
1.2	ZINC	1. CHEMICAL COMP.	MA	CHEM. TEST	SAMPLE	IS 209	IS 209	QC RECO RD	✓	P	V	-	
2.0	IN PROCESS:												
2.1	CUTTING, DRILLING	1. DIMENSIONS 2. SURFACE FINISH	MA	MEASUREMENT VISUAL	100%	APPROVED DATA SHEET / DRAWING	APPROVED DATA SHEET / DRAWING	QC RECO RD TEST/ INSPN. REPO RT	✓	P	V	-	

BHEL				BIDDER/ SUPPLIER				FOR CUSTOMER REVIEW & APPROVAL							
ENGINEERING		QUALITY		Sign & Date		Sign & Date		Doc No:		Sign & Date		Name		Seal	
Prepared by:	MANISH SINGH	Name	VIKAS KUMAR SINGH	Checked by:	RITESH KUMAR	Name	KUNAL GANDHI	Reviewed by:	MANISH SINGH	Name		Seal			
Reviewed by:	MANISH SINGH	Reviewed by:	MANISH SINGH	Reviewed by:	RITESH KUMAR	Reviewed by:	RITESH KUMAR	Approved by:	MANISH SINGH	Approved by:	RITESH KUMAR				

		MANUFACTURER/ BIDDER/ SUPPLIER NAME & ADDRESS				STANDARD QUALITY PLAN				SPEC. NO : QP NO.: PE-QP-999-509-E001, R2.		DATE: 02.11.2020		
		PROJECT: ITEM: ABOVE GROUND EARTHING MATERIALS				SYSTEM: EARTHING				PO NO.:		SECTION: II		SHEET 2 OF 5
Sl. No.	COMPONENT S & OPERATIONS	CHARACTERISTICS	CLASS	TYPE OF CHECK	QUANTUM OF CHECK	REFERENCE DOCUMENT	ACCEPTANCE NORMS	FORMAT OF RECORD	AGENCY			REMARKS		
1	2	3	4	5	M 6 C/N	7	8	9	*	D	M	C	N	

2.2	SURFACE PREPARATION	1. CLEANING, PICKLING, RINSING & FLUXING 2. SURFACE FINISH	MA	VISUAL	100%	IS 2629	IS 2629	QC RECO RD	✓	P	-	-		
2.3	GALVANISING	1. TEMPERATURE OF BATH 2. DROSS	MA	MEASUREMENT VISUAL	CONTINUOUS PERIODIC	IS 2629	IS 2629	QC RECO RD	✓	P	-	-		Galvanization is to be done at galvanization plant listed in annexure-1 to quality plan.
		3. RATE OF IMMERSION	MA	VISUAL / MEASUREMENT	100%	IS 2629	IS 2629	QC RECO RD	✓	P	-	-		
		4. SURFACE FINISH	MA	VISUAL	100%	IS 2629	FREE FROM BURRS, ROUGHNESS, SLAG, FLUX, STAIN	QC RECO RD	✓	P	-	-		Note: sample for chemical test shall be
3.0	FINISHED ITEMS:													

BHEL				QUALITY			
ENGINEERING		SIGNATURE		SIGNATURE		SIGNATURE	
Prepared by:	VIKAS KUMAR SINGH	Name:	VIKAS KUMAR SINGH	Checked by:	RITESH KUMAR	Name:	KUNAL GANDHI
Reviewed by:	MANISH SHUKLA	Reviewed by:	MANISH SHUKLA	Reviewed by:	RITESH KUMAR	Reviewed by:	RITESH KUMAR
							JAI SWAL

BIDDER/ SUPPLIER	
Sign & Date	Sign & Date
Seal	Seal

FOR CUSTOMER REVIEW & APPROVAL			
Doc No:	Sign & Date	Name	Seal
Reviewed by:			
Approved by:			

	STANDARD QUALITY PLAN			SPEC. NO.: QP NO.: PE-QP-999-509-E001, R2.		DATE: 02.11.2020
	CUSTOMER: PROJECT:			PO NO.:		
	ITEM: ABOVE GROUND EARTHING MATERIALS			SYSTEM: EARTHING		SECTION: II
						SHEET 4 OF 5





Sl. No.	COMPONENT S & OPERATIONS	CHARACTERISTICS	CLASS	TYPE OF CHECK	QUANTUM OF CHECK		REFERENCE DOCUMENT	ACCEPTANCE NORMS	FORMAT OF RECORD	AGENCY				REMARKS
					M	C/N				M	C	N		
1	2	3	4	5	6	7	8	9	*	D	**			

Sl. No.	COMPONENT S & OPERATIONS	CHARACTERISTICS	CLASS	TYPE OF CHECK	QUANTUM OF CHECK		REFERENCE DOCUMENT	ACCEPTANCE NORMS	FORMAT OF RECORD	AGENCY				REMARKS	
					M	C/N				M	C	N			
	4. MASS OF ZINC COATING		MA	CHEM. TEST	REFER REMARKS	IS-6745 / APP. DATA SHEET	APP. DATA SHEET	INSPEC. REPO RT	✓	P	W	-	10001 and above	50	5
	5. UNIFORMITY OF ZINC COATING		MA	CHEM. TEST	IS-4759	IS-2633	IS-2633	INSPEC. REPO RT	✓	P	W	-			
	6. THICKNESS OF ZINC COATING		MA	MEASUREMENT	IS-4759	APP. DATA SHEET	APP. DATA SHEET	INSPEC. REPO RT	✓	P	W	-			
	7. ADHESION		MA	MECH. TEST	IS-4759	IS 2629	IS 2629	INSPEC. REPO RT	✓	P	W	-			

Note: Items like Pipes/ Flexible Copper Braid/ GI wire/ GS Rod/ Shielding Mast/ Test link will be cleared based on COC (certificate of Compliance)

4.0	PACKING	SURFACE FINISH & COMPLETENESS	MA	VISUAL	100%	AS PER MFG. STANDARD / (#)	AS PER MFG. STANDARD / (#)	INSPEC. REPO RT	✓	P	W	-			(#) REFER NOTE-5
-----	---------	-------------------------------	----	--------	------	----------------------------	----------------------------	-----------------	---	---	---	---	--	--	------------------

NOTES:
 1. BHEL reserves the right to perform repeat test, if required.
 2. In case of foreign supplier, all test certificates shall be furnished by the supplier, duly witnessed/ verified by supplier's TPI.

ENGINEERING				QUALITY			
Sign & Date	Name	Sign & Date	Name	Sign & Date	Name	Sign & Date	Name
 VIKAS KUMAR SINGH	VIKAS KUMAR SINGH	 RITESH KUMAR	KUNAL GANDHI	 RITESH KUMAR	RITESH KUMAR	 RITESH KUMAR	JAIJSWAL
Prepared by:	MANISH SINGH	Checked by:	VIKAS KUMAR SINGH	Reviewed by:	MANISH SHUKLA	Approved by:	JAIJSWAL

BIDDER/ SUPPLIER	
Sign & Date	Seal
Doc No:	Reviewed by:
	Approved by:

FOR CUSTOMER REVIEW & APPROVAL			
Doc No:	Sign & Date	Name	Seal

STANDARD QUALITY PLAN		SPEC. NO. : QP NO.: PE-QP-999-509-E001, R2.		DATE: 02.11.2020	
MANUFACTURER/ BIDDER/ SUPPLIER NAME & ADDRESS		CUSTOMER :			
PROJECT:		PO NO.:			
ITEM: ABOVE GROUND EARTHING MATERIALS		SYSTEM: EARTHING		SECTION: II	
				SHEET 5 OF 5	

Sl. No.	COMPONENT S & OPERATIONS	CHARACTERISTICS	CLASS	TYPE OF CHECK	QUANTUM OF CHECK	REFERENCE DOCUMENT	ACCEPTANCE NORMS	FORMAT OF RECORD	AGENCY	REMARKS	
1	2	3	4	5	6	7	8	9	D		
					M	C/N		*	M	C	N

3. Photographs of items duly placed inside the box just before the final packing and Photographs of the box just before dispatch to be sent to BHEL purchase group for review before issuing MDCC.

4. In case of any changes in QP commented by customer at contract stage, same shall be carried out by bidder without any implication to BHEL/ Customer.

5. Project specific QP to be developed based on customer requirement.

6. For export job, BHEL technical specification for seaworthy packing for export job to be followed.

7. Material shall be packed suitably in order to avoid damage during transit and also during storage at site in tropical climate conditions. Packing shall be suitable for storage at site in tropical climate conditions.

8. Latest revision/ year of issue of all the standards (IS/ASME/IEC etc.) indicated in QP shall be referred.

LEGENDS:

*RECORDS, IDENTIFIED WITH "TICK"(✓) SHALL BE ESSENTIALLY INCLUDED BY SUPPLIER IN QA DOCUMENTATION,
 ** M: SUPPLIER/ MANUFACTURER/ SUB-SUPPLIER, C: MAIN SUPPLIER/ BHEL/ THIRD PARTY INSPECTION AGENCY, N: CUSTOMER,
 P: PERFORM, W: WITNESS, V: VERIFICATION, AS APPROPRIATE
 MA: MAJOR, MI: MINOR, CR: CRITICAL
 D: DOCUMENTATION

BHEL				FOR CUSTOMER REVIEW & APPROVAL			
ENGINEERING		QUALITY		BIDDER/ SUPPLIER		Doc No:	
Sign & Date	Name	Sign & Date	Name	Sign & Date	Name	Sign & Date	Name
Prepared by: VIKAS KUMAR SINGH	VIKAS KUMAR SINGH	Checked by: 	KUNAL GANDHI	Reviewed by: MANISH SHUKLA	MANISH SHUKLA	Approved by: RITESH KUMAR	RITESH KUMAR

ANNEXURE-1 to Quality Plan

(LIST OF BHEL- PEM APPROVED GALVANIZERS)

SL. NO.	ITEM	VENDOR NAME	ADDRESS
1	Galvanising	Jenco Industrial Corporation	Chincholi Bunder Khkar Road Near Link Road Devruwadi Malad (W) Mumbai 400064
2	Galvanising	National Galvanizing Company	66, Barrackpore Kamarhatt Trunck Road Calcutta-700058
3	Galvanising	Sigma Galvanising Pvt. Ltd.	Plot No.C-169, TTC, MIDC Ind Area Navin Mumbai-400705
4	Galvanising	B.P. Projects PVT LTD	167A, Vivekananda Road Kolkata-700006
5	Galvanising	Standard Galvanisers	Makardah Road, Kabar Para, Bankra, Howarah -711403
6	Galvanising	Steel Products	National Highway No. 6, Chamrail, Kona, Howrah-711114
7	Galvanising	Unitech Fabricators & Engineers Pvt. Ltd.	Village- Ajab Nagar, P.O. -Molla Simlla, P.S. - Singur, Dist - Hoogly, Pin-712223
8	Galvanising	Shivam Engineers & Fabricators	A0-282-284, Industrial Area, South Side of G.T. Road, Ghaziabad, U.P.
9	Galvanising	B.G. Shirke Construction Technology Pvt. Ltd	72-76, Mundhawa, Pune - 401 036
10	Galvanising	Galbro Ispat Galvanizers Pvt. Ltd.	GUT 11 AND 12, OPP. Kudus Steel,Rolling Mill, Wada, Thane , Mumbai
11	Galvanising	Eros Metals	G-97, MIDC, Bhutibori , Nagpur
12	Galvanising	Industrial Perforation (India) Pvt. Ltd.	Ganganagr, Katakhal, Kolkata-700132
13	Galvanising	Indmark Formtech Pvt. Ltd.	Phase - 3, E - 11 / 1, M. I. D. C., Chakan, Pune - 410 501, Maharashtra, India.
14	Galvanising	Namdhari Industrial Traders Pvt. Ltd.	Village Latton Dana, Chandigarh Road, Ludhiana
15	Galvanising	Neha Galvaniser	Jalan Industrial Estate, Gate No-1, 1st Right Choise Lane, Near N.G-6, Jangalpur, PO Domjur Howrah - 700071, West Bengal, India
16	Galvanising	Patny Systems (P) Ltd.	Unit-IV, Sy No. -228/9, Plot No. 6, IP Kuchavaram, Toopran(M) Dist.- Medak, Telegana - 502336
17	Galvanising	Parmar Metal Company	Survey No.207,Veraval (Shapar) Dist. Rajkot, India.
18	Galvanising	Passive Infra Projects Pvt. Ltd	8th KM Stone, Sampla Kharkhoda Road, Hassangarh, Rohtak, Haryana
19	Galvanising	Rukmani Electrical & Fabricators Pvt, Ltd.	Urla Industrial Area, Urla Sarora Road, Raipur- 493 221 (Chhattisgarh) Shankharidaha Baniyarah, Jalan Industrial Complex, Gate no.3, Lane no. 4, Domjur, Howrah , W.B .- 71141
20	Galvanising	DMP Projects Pvt.Ltd.	Dulagarh Industrial Park , PS-Sankrail , Howrah -711302
21	Galvanising	Vinfab Engineers India Private Limited	Gut no. 224/1 &2 Bhiwandi Wada State Highway, Village khupri, Dist. Thane, Maharashtra -421303
22	Galvanising	Saral Projects & Processors	B-1, Industrial Area, Site-II, Amawan Road Rae Bareli
23	Galvanising	Jamna Metal Company	D - 1513, DSIDC, Narela Industrial Area Delhi - 110040, India
24	Galvanising	Brahampuri Steels Limited	172 (F) Industrial Area, Jhotwara, Jaipur-302013
25	Galvanising	Indiana Gratings PVT. LTD	F-5, MIDC Jejuri, Pune-412 303

NOTES:

1. ANY CHANGE IN THE ABOVE LIST SHALL BE INFORMED AT THE TIME OF SPECIFIC PROJECT REQUIREMENT AND NO COMMERCIAL IMPLICATION SHALL BE ALLOWED ON THIS ACCOUNT.

2. IT SHALL BE THE RESPONSIBILITY OF THE VENDOR TO GET THE MATERIAL GALVANIZED FROM THE ABOVE LIST WITHOUT ANY COMMERCIAL IMPLICATION TO BHEL.

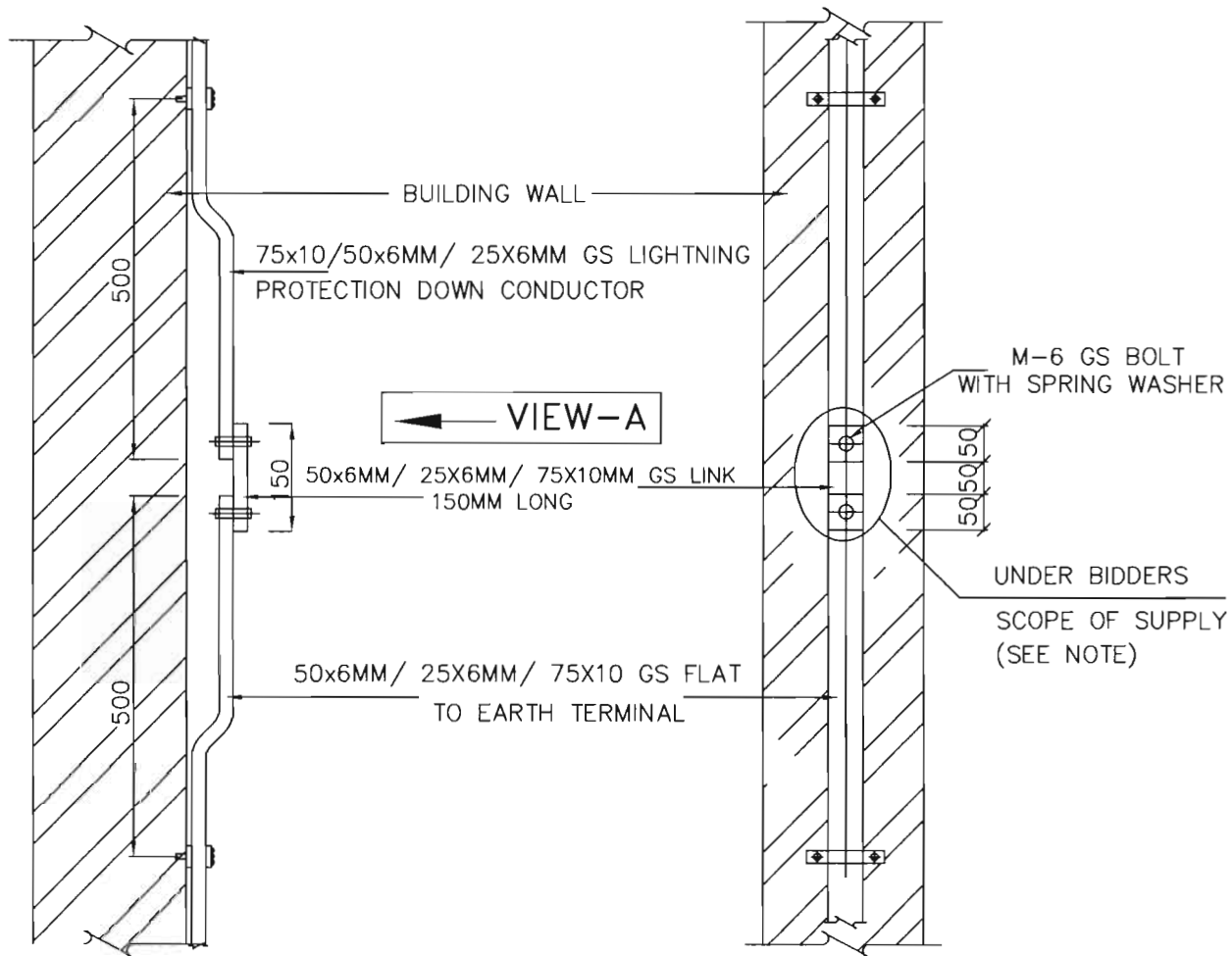

TEST LINK DETAILS

VIEW-A

NOTE: BIDDER'S SCOPE INCLUDES THE 150 MM LONG 50X6MM/ 25X6MM/ 75X10MM GS LINK ALONG WITH HARDWARES (2 NOS. M-6 GS NUTS & BOLTS & 4 NOS. SPRING WASHERS)



TITLE

TYPICAL DETAILS OF TEST LINK

PE-DG-999-509-E003

SH 1 OF 4

REV 02

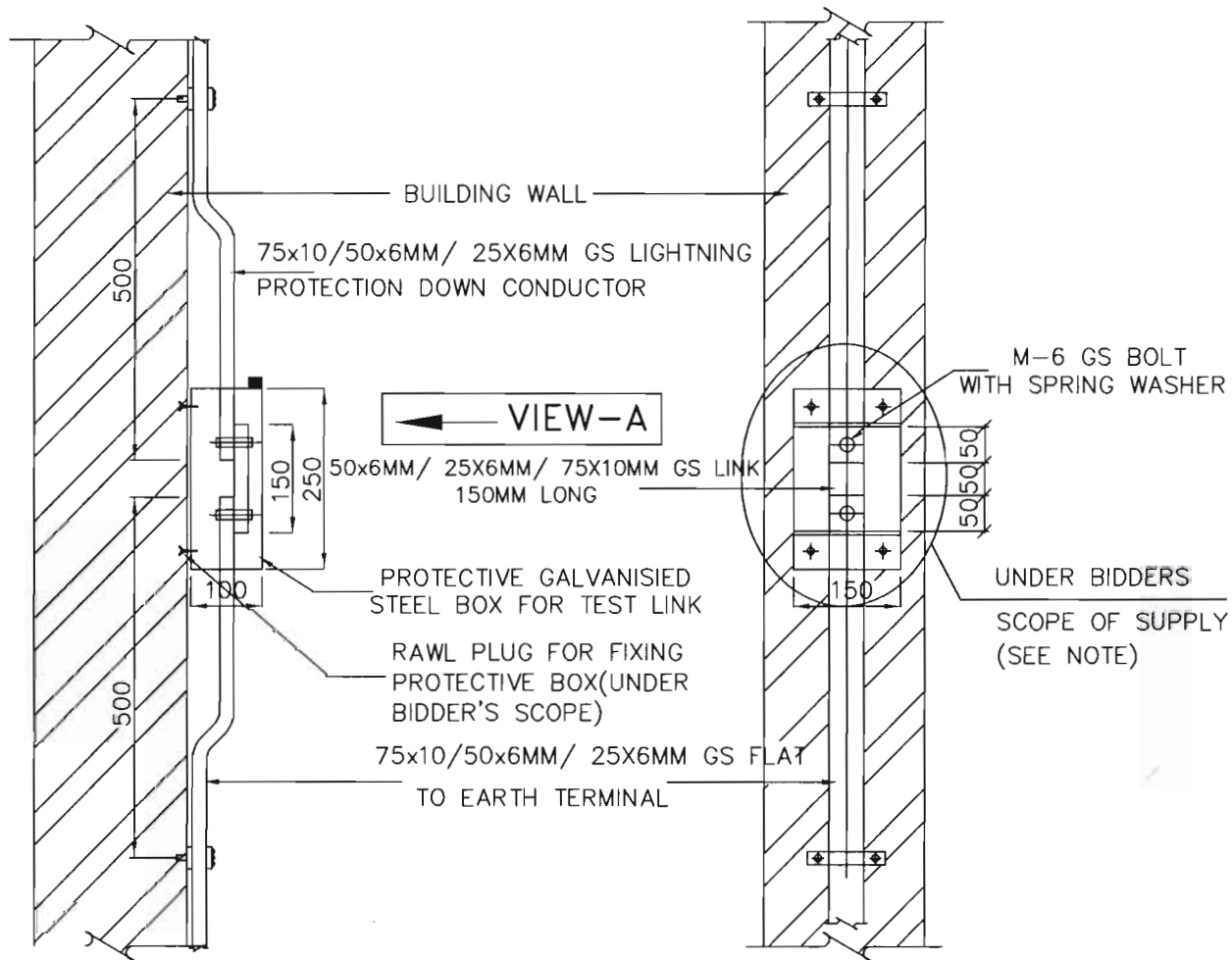

TEST LINK WITH BOX DETAILS VIEW-A

NOTE: BIDDER'S SCOPE INCLUDES THE 150 MM LONG 50X6MM/ 25X6MM GS LINK ALONG WITH HARDWARES (2 NOS. OF M-6 GS NUTS & BOLTS & 4 NOS. SPRING WASHERS) & 250X150X100 MM GALVANISED MS COVERING BOX (1.6 MM THICK) WITH 4 NOS. M12 SCREWS & RAWL PLUGS FOR FIXING OF THE SAME.



TITLE

**TYPICAL DETAILS OF TEST LINK
WITH PROTECTIVE BOX**

PE-DG-999-509-E003

SH 2 OF 4

REV 02

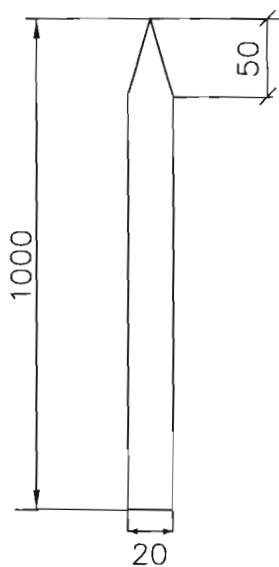

20MM DIA GS ROD

FOR LIGHTNING PROTECTION

REMOVABLE CAP WITH WIRE MESH

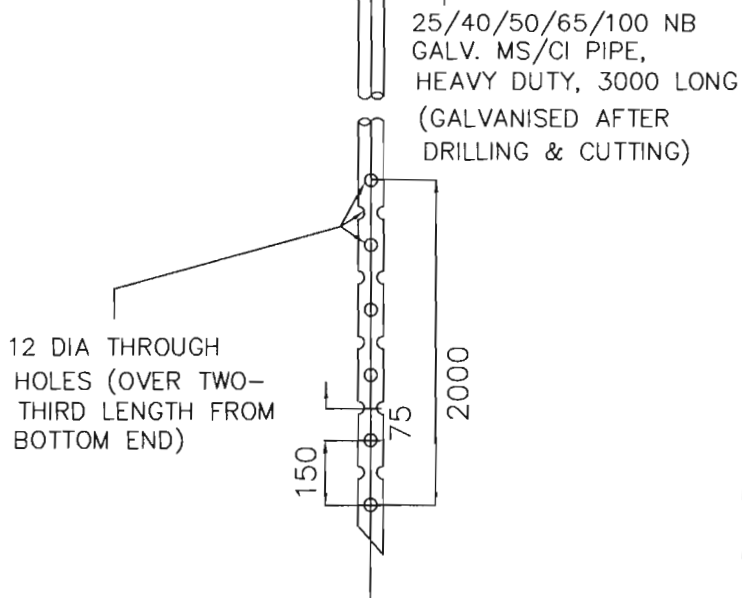

PERFORATED PIPE

600MM Length (Cross section equivalent to 300 Sq.MM)

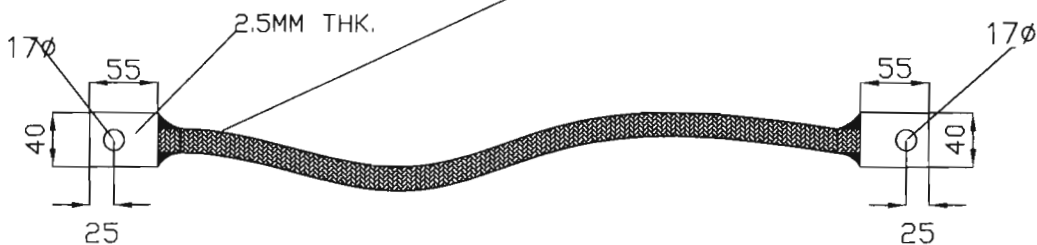

FLEXIBLE BRAIDED COPPER CONDUCTOR

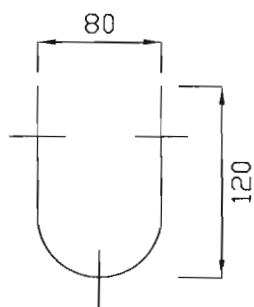

PLAN

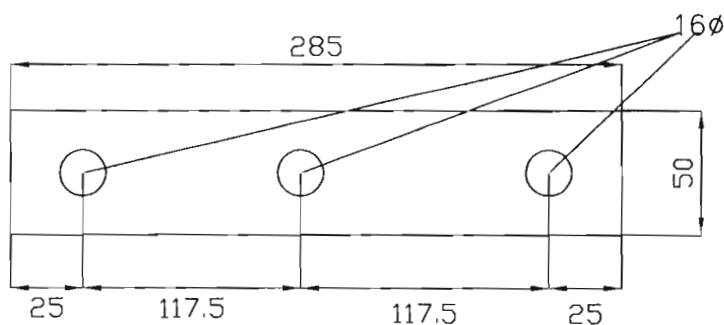

TINNED COPPER 'U' CLAMP (2.5 MM THICK)

TITLE



TYPICAL DETAILS OF FLEXIBLE
BRAIDED COPPER, 20 MM DIA.
GS ROD & PERFORATED PIPE

PE-DG-999-509-E003

SH 3 OF 4

REV 02

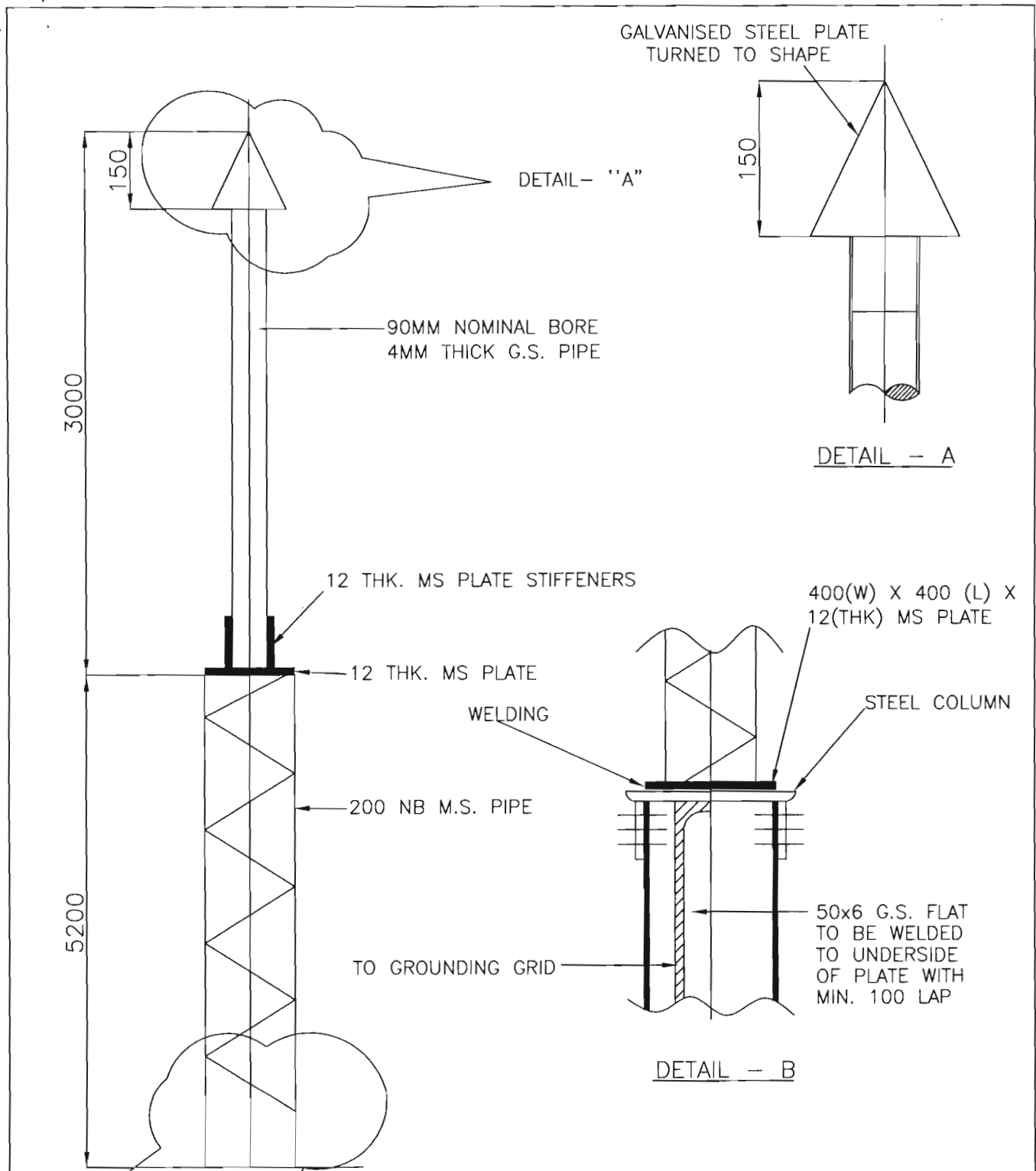

FIXING DETAILS OF SHIELDING MAST ON TOP
STEEL COLUMNS OF POWER HOUSE BUILDING
(FOR LIGHTNING PROTECTION)

NOTES:

1. THE ABOVE SHIELDING MAST SHALL BE PROVIDED ON TOP OF "A" ROW STEEL COLUMNS OF POWER HOUSE BUILDING
2. ALL DIMENSIONS ARE IN MM.



TITLE

TYPICAL DETAILS OF
SHIELDING MAST

PE-DG-999-509-E003

SH 4 OF 4

REV 02

	<u>Price Variation Formulae</u>	ANNEXURE-B
---	---------------------------------	-------------------

Prices shall be variable as per following PVC formulae:-

ABOVE GROUND EARTHING & LIGHTNING PROTECTION MATERIALS	
$P = P_o/100 (20 + 70 (Fe/Fe_o) + 10 (W/ W_o))$	Indices to be taken from IEEMA Circular (PVC/LA conductor-LME) for the applicable month.

Wherein,

P = Ex-works price payable as adjusted in accordance with the price variation clause.

P_o = Ex-works price quoted/confirmed.

FE_o = Price of High Tensile Galvanized Steel Wire in Rs./MT of appropriate size. This price is applicable prevailing as on 1st working day of the month **one** month prior to date of tender enquiry.

W_o = All India average consumer price index number for industrial workers, as published by the Labour Bureau, Ministry of Labour, Govt. of India (Base: 2016 = 100). This index number is as applicable on the first working day of the month, **one** month prior to date of tender enquiry.

FE = Price of High Tensile Galvanized Steel Wire in Rs./MT of appropriate size. This price is applicable prevailing as on first working day of the month **one** month prior to the date of inspection call.

W = All India average consumer price index number for industrial workers, as published by the Labour Bureau, Ministry of Labour, Govt. of India (Base: 2016 = 100). This index number is as applicable on the first working day of the month, **one** month prior to the date of inspection call.

NOTE: PVC shall be applicable for 'GS FLATS & GI WIRES' only.

Price of FE & FE_o shall be of 3.00 to 4.09 mm High Tensile Galvanized Steel Wire.

Price variation shall be limited to +20% of total Ex-works price actually supplied and no limit on -ve price variation with base month of one month prior to date of tender enquiry for the items where PVC is applicable.