

भारत हेवी इलेक्ट्रिकल्स लिमिटेड
(भारत सरकार का उपक्रम)



Bharat Heavy Electricals Limited

(A Govt. of India Undertaking)
Power Sector - Southern Region
New No.690 (Old No.474), Anna Salai,
Nandanam, Chennai-600 035.
Phone : 2433 0015 (10 Lines)
Grams : BHELPOWER

BHEL PSSR SCT 1375

DATE: 03.02.2010

CORRIGENDUM TO TENDER NOTICE SCT 1375

TENDER SPECIFICATION NO BHEL: PSSR: SCT: 1375

Sub: Construction of 2 nos of 120Mtr RCC Chimney-civil, structural, electricals, C&I and allied works at Phase III Refinery Project for MRPL-CPP, Mangalore

1. DUE DATE EXTENDED

TENDER SALE CLOSURES ON : 06.02.2010
DUE DATE & TIME FOR TENDER SUBMISSION : 08.02.2010 15.00hrs
DUE DATE & TIME FOR OPENING OF TECHNICAL BIDS : 08.02.2010 15.30hrs

2. CLARIFICATIONS TO SCT 1375

SUB: SCT 1375 Construction of 2 nos of 120Mtr RCC Chimney-civil, structural, electricals, C&I and allied works at Phase III Refinery Project for MRPL-CPP, Mangalore

Some of the bidders sought clarifications in the above tender and our clarifications are furnished below for your information

Q1: Since the drawings have not been made available to the tenderer, we request you to kindly confirm whether the proposed 120m height chimney will be uniform or tapered chimney of varying diameter. Also kindly provide us detailed drawing showing detailed components of chimney.

Reply: Drawings cannot be provided at this stage. However this chimney is outside tapered and flushed inside.

Q2: Kindly confirm to whether the cost of materials to be included in our quote rates for item No.6.40 and 6.50 of BOQ?

Reply: As per Item specification only.

Q3: BOQ No: 11.2a to g refers to Mounting of Aviation lamps and accessories shall be as per typical installation standard No.7-51-0220Rev 02(attached).But this standard drawing is not attached with technical specifications. Hence we request you to make this standard available to us at the earliest please.

Reply: The required drawing is enclosed for your reference.

ALL OTHER CONDITIONS REMAIN UNCHANGED.

AGM / CONTRACTS

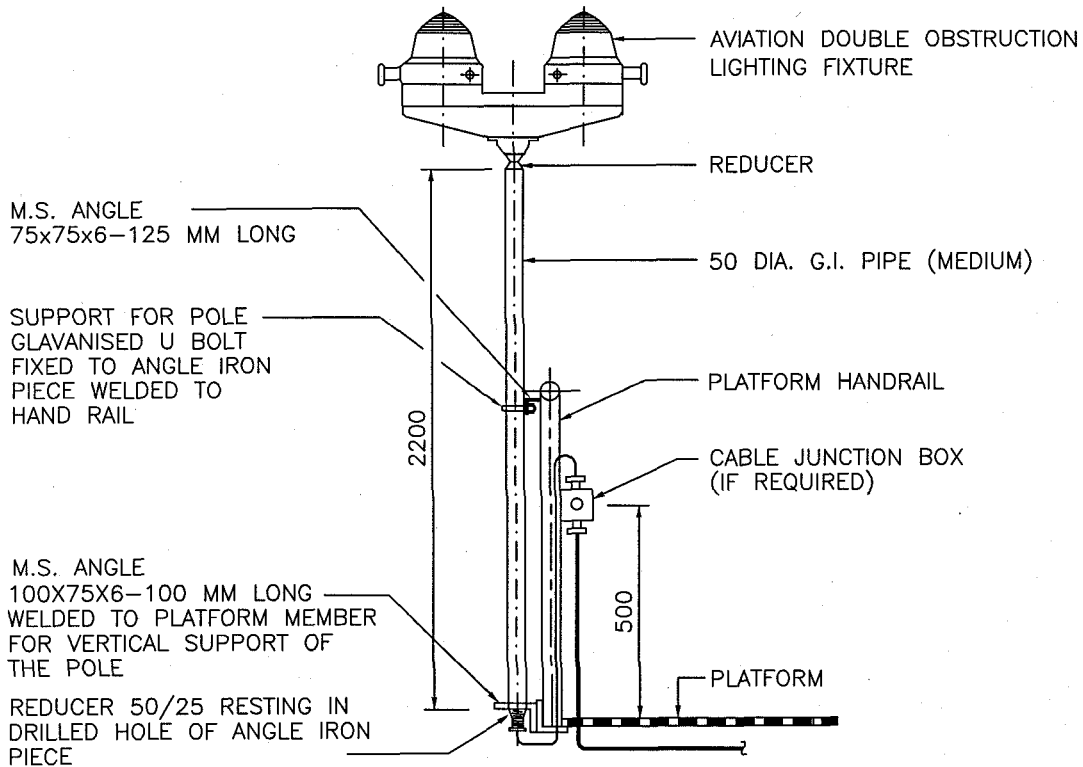

MOUNTED ON TOP OF STRUCTURE PLATFORM
DETAIL-1

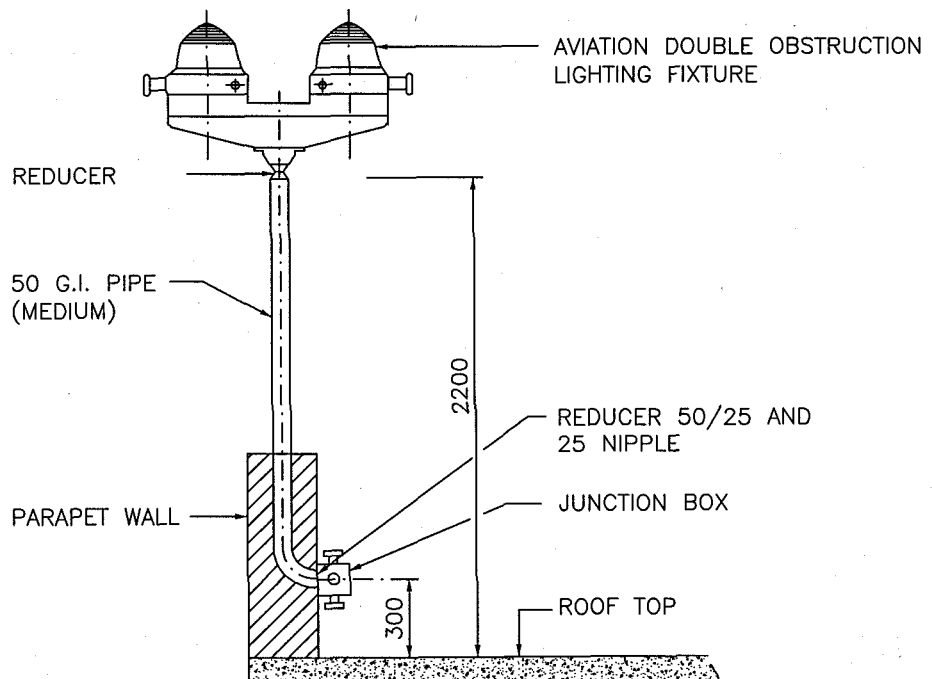

MOUNTED ON TOP OF BUILDING PARAPET WALL
DETAIL-2

NOTES:—

1. ALL DIMENSIONS ARE IN MM.

2	10.06.03	REVISED AND ISSUED AS STANDARD	<i>Arjun</i>	<i>De</i>	<i>Sh</i>	<i>Arjun</i>
1	31.03.98	UPDATED AND ISSUED AS STANDARD	PC	BLC/RR	VPS	ASONI
Rev. No.	Date	Purpose	Prepared by	Checked by	Stds. Committee Convenor	Stds. Bureau Chairman
						Approved by