



Tender Enquiry No. B/4011/2023/0672/V1 for the requirement of HPSU WITH SPARES for Talcher project ON GeM Portal

LIST OF ENCLOSURES

	<u>Document</u>	<u>Number of pages</u>
1.	PRE-QUALIFICATION REQUIREMENT	02
2.	WRITE UP ON HYDRAULIC POWER SUPPLY UNIT FOR 660/800 MW STEAM TURBINE SET	03
3.	NTPC SUB-VENDOR QUESTIONNAIRE	03
4.	BUYER SPECIFIC TERMS & COND SPECIAL CONDITIONS OF TENDER	09
5.	MADE IN INDIA DECLARATION FORMAT	01
6.	BHEL STANDARD PBG FORMAT	02
7.	FCA FORMAT	07
8.	BHEL QP FORMAT	01
	TOTAL PAGES	28

Sachin Gupta (Engineer/PPX-BOI)
Email: gupta.sachin@bhel.in
Ph. 01334-281690

Pankaj Kumar (Manager/ PPX-BOI)
Email: ssbgpankaj@bhel.in
Ph. 01334- 281690

Pre-qualification requirements for "Hydraulic Power Supply unit for main turbine valves"

Cl. No.	Pre-qualification requirements	Vendor response
1	<p>The vendor should have the experience of Design, Manufacturing, Testing & Supply of Hydraulic Power Supply Unit (HPSU) used for operation of main turbine valves of steam turbine having name plate rating 660 MW or above, with technical parameters listed below. The vendor to confirm.</p> <p>i) Operating pressure of Control Fluid: ≥ 160 bar ii) Operating Control Fluid: Fire Resistant Fluid (FRF)- HFDR Type (ISO 6743/4) iii) Main Control Fluid Pump Flow: ≥ 43 LPM iv) Main Control Fluid Pump Type: 2X100% Axial Piston Pump v) Main line filter: ≤ 10 microns vi) Cooling cum Recirculation Pump Type: 2X100% vii) Return filter: ≤ 3 microns viii) Regeneration circuit: Applicable ix) Bladder Accumulator: Applicable x) Tank Capacity: ≥ 800 Liter xi) Material of Tank shall be Stainless Steel.</p> <p>In support of experience, vendor to submit details of their past supply in the experience list format as per Annexure-1 (copy enclosed).</p>	
2	<p>The vendor to confirm that they must have previously supplied & commissioned the required instrumentation i.e. Transmitters, switches, RTDs, DPS and gauges compatible with HPSU of main turbine valves for steam turbine applications.</p>	
3	<p>The vendor to confirm that they must have experience of satisfactory operation of Hydraulic Power Supply Unit for main turbine valves (referred at Cl. No.-1 above) for at least one steam turbine unit having name plate rating 660 MW or above, for minimum one year as on date of issuance of enquiry.</p>	
4	<p>The vendor to furnish the following documents of supplied HPSU (complying Cl. No.-1 & 3 above) for our review.</p> <p>A. GA drawing, datasheet, schematic drawing & BOM of HPSU. B. Copy of Purchase order, Test reports of the project and Commissioning protocols at project site. The date of Purchase order (P.O.) shall not be prior to 01.01.2015. OR Certificates of satisfactory operation from their customer/End user. The date of issue of experience certificate shall not be prior to 01.01.2015. For vendors who have supplied HPSU (complying Cl. No.-1 & 3 above) earlier to BHEL, Haridwar may inform P.O. nos. only.</p>	

Note:
 1- Against vendor's replies, BHEL reserves the right to ask for more information/documents/clarifications. Vendor's offer shall not be considered if vendor fails to furnish the document/information/clarifications as mentioned above or vendor doesn't meet the acceptance criteria (mentioned above from Cl. No.-1 to 4).
 2- A brief write up on **Hydraulic Power Supply unit for main turbine valves** is also enclosed as **Annexure-2**.

Dy. Manager/CIE

Sr. Manager/CIE

AGM/CIE

Sr. Manager/STE-TG

AGM/STE-TG & TM

AGM (STE)

On leave
For joint no. - 2 only
21/06/2022

Saswati
22/6/2022

22/06/22

21/06/2022

22/6/22

Annexure – 1 (Experience list format)

Sl. No.		Parameters	Steam Turbine unit 1
1.	Name of the station and it's Location		*
2.	Customer name and its address, Fax no. & Tel. No.		*
3.	Name, designation, e-mail ID & Mobile no. of the responsible person in customer's organization		*
4.	Purchase Order No. & Date		*
5.	Name plate rating in MW of individual Steam turbine unit	≥ 660 MW	*
6.	Date of Commissioning of HPSU		*
7.	Years of successful operation as on date of issuance of enquiry	1 years (Min.)	*
8.	Brief Scope of work		*
9.	Designed by		*
10.	Manufactured by		*
11.	Operating Pressure of Control Fluid	≥160 bar	*
12.	Operating Control Fluid	Fire Resistant Fluid (FRF)- HFDR Type (ISO 6743/4)	*
13.	Main Control Fluid Pump Flow	≥ 43 LPM	*
14.	Main Control Fluid Pump Type	2X100% Axial Piston Pump	*
15.	Main line filter	≤ 10 microns	*
16.	Cooling cum Recirculation Pump Type	2X100%	*
17.	Return filter	≤ 3 microns	*
18.	Regeneration circuit	Applicable	*
19.	Bladder Accumulator	Applicable	*
20.	Tank Capacity	≥ 800 Liter	*
21.	Material of Tank	Stainless Steel	*
22.	HPSU for turbine valves :		
a	Main Control Fluid Pump		
i	Type		
ii	make		
iii	Flow		
v	Quantity		
b	Cooling cum Recirculation pump type & make		
i	Type		
ii	Make		
iii	Flow		
v	Quantity		
c	Regeneration circuit type		
d	Main line filter type, size & flow capacity		
e	Return line filter type, size & flow capacity		
f	Regeneration circuit filter type, size & flow capacity		
g	Dehumidifier/ air ventilation filter detail		
h	Bladder Accumulator details (no., size, material & make)		
i	Cooler details (like Type, size, Material etc.)		
j	Heater details (like Type, size, Material etc.)		

Note:

(i)- Vendor to fill the applicable data in the format given above.

(ii)- Further the data against Sl. No.- 1, 2, 3, 4, 5, 6, 7, 8, 9, 10, 11, 12, 13, 14, 15, 16, 17, 18, 19, 20, 21 (marked as *) are to be **mandatorily** filled by the vendor.

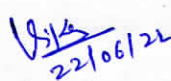
 22/06/22
 (Vikas Mathotra)
 Sr. Manager (STE-TG)



WRITE UP ON HYDRAULIC POWER SUPPLY UNIT FOR 660/800 MW STEAM TURBINE SETS

HYDRAULIC POWER SUPPLY UNIT

The main function of Hydraulic power supply unit (HPSU, MAX01) is to supply Control Fluid at 160 bar pressure with a predetermined flow rate to operate respective Electro-Hydraulic Actuators (EHAs), coupled with main turbine valves (HP, IP & Overload Valve).

HPSU (MAX01) comprises of major components i.e. control fluid pumps (Axial Piston Pump, MAX01 AP001/AP002), filters (MAX01 AT011/AT012/AT013/AT014/AT016), control fluid regeneration unit (MAX01 AT015), control fluid cooler (MAX01 AC010/AC020), control fluid heater (MAX01 AH001), Hydraulic pressure Accumulators (MAX01 BB011/BB012/BB013/BB014), Temperature regulator (MAX01 AA151 AA152) etc. These components are mounted on the control fluid tank of HPSU. All the piping/component coming in contact with FRF are made of stainless steel.

For the redundancy and to prolong the service life of the unit, 2X100% control fluid pumps (MAX01 AP001/AP002) are provided for control fluid supply. In case of an on-line pump failure, operation is automatically switched over to the stand by pump. The pump function in pressure controlled mode i.e. they charge the accumulator system to 160 bar and then limit the displacement volume so that the system pressure of 160 bar is maintained constant. The electric motors and pressure relief valves (MAX01 AA061/AA062) for system pressure adjustment are mounted on the control fluid tank cover. Simplex filter (MAX01 AT011/AT012) at downstream of each control fluid pump (MAX01 AP001/AP002) have been provided having mesh size 10 μ . The filters (MAX01 AT011/AT012) are equipped with clogging indicator (MAX01 CP011/CP012) for alarm, in case of choke.

The accumulators system (MAX01 BB011/BB012/BB013/BB014), which is to supply the fluid quantity required for control movements of power piston, comprises a group of bladder-type accumulators with isolating valves and safety valves. The bladder accumulators (40 MAX01 BBO11/BB012/BB013/BB014) are fixed at the rear side.

The supply unit is of compact design. It comprises a tank made of stainless steel with fluid level monitoring devices (MAX01 CL501) as well as breather filter (MAX01 AT001). Moreover, a drip tray is provided at the bottom, which is at the lowest point. All electric devices are wired to a terminal strip in the terminal box (MAX01 GF001). There are total 5 nos. pressure connections (X1, X2, X3, X4 & X5) and 5 nos. return connections (T1, T2, T3, T4 & T5) have been provided in the HPSU for further connecting the control fluid pipe to various actuators.

Separate cooling-cum-filtration circuit is provided in order to maintain the cleanliness of the system and to ensure proper cooling. Separate 2X100% capacity AC driven circulation pumps (MAX01 AP011/AP012) supply fluid to this circuit. On the tank cover a console is mounted which contains the local pressure gauges, pressure switches and

**WRITE UP ON HYDRAULIC POWER SUPPLY UNIT FOR 660/800 MW STEAM TURBINE SETS**

nipples for commissioning measurements. The recirculation pumps (MAX01 AP011/AP012) supply the control fluid to the cooler (MAX01 AC010/AC020) through temperature regulator (MAX01 AA151/AA152). The temperature regulator (MAX01 AA151/ AA152) is set on 45 deg C. Only in case the control fluid temperature is greater than 45 deg C, the temperature regulator allows the control fluid to be passed through the cooler (MAX01 AC010/AC020), else it supplies the control fluid directly to the tank via fine filter (MAX01 AT013/AT014).

A separate regeneration circuit is provided in the HPSU with 2X100% capacity AC driven regeneration pump (MAX01 AP011/AP012). The regeneration unit pumps (MAX01 AP011/AP012) supply the control fluid from tank to control fluid regeneration unit (MAX01 AT015). In control fluid regeneration unit (MAX01 AT015), control fluid gets reconditioned and return back to tank via a filter (MAX01 AT016). The regeneration circuit is designed to purify at least 2% of the total fluid charge in the system per hour on continuous basis.



WRITE UP ON HYDRAULIC POWER SUPPLY UNIT FOR 660/800 MW STEAM TURBINE SETS

The typical schematic diagram of Hydraulic Power Supply Unit is shown below:

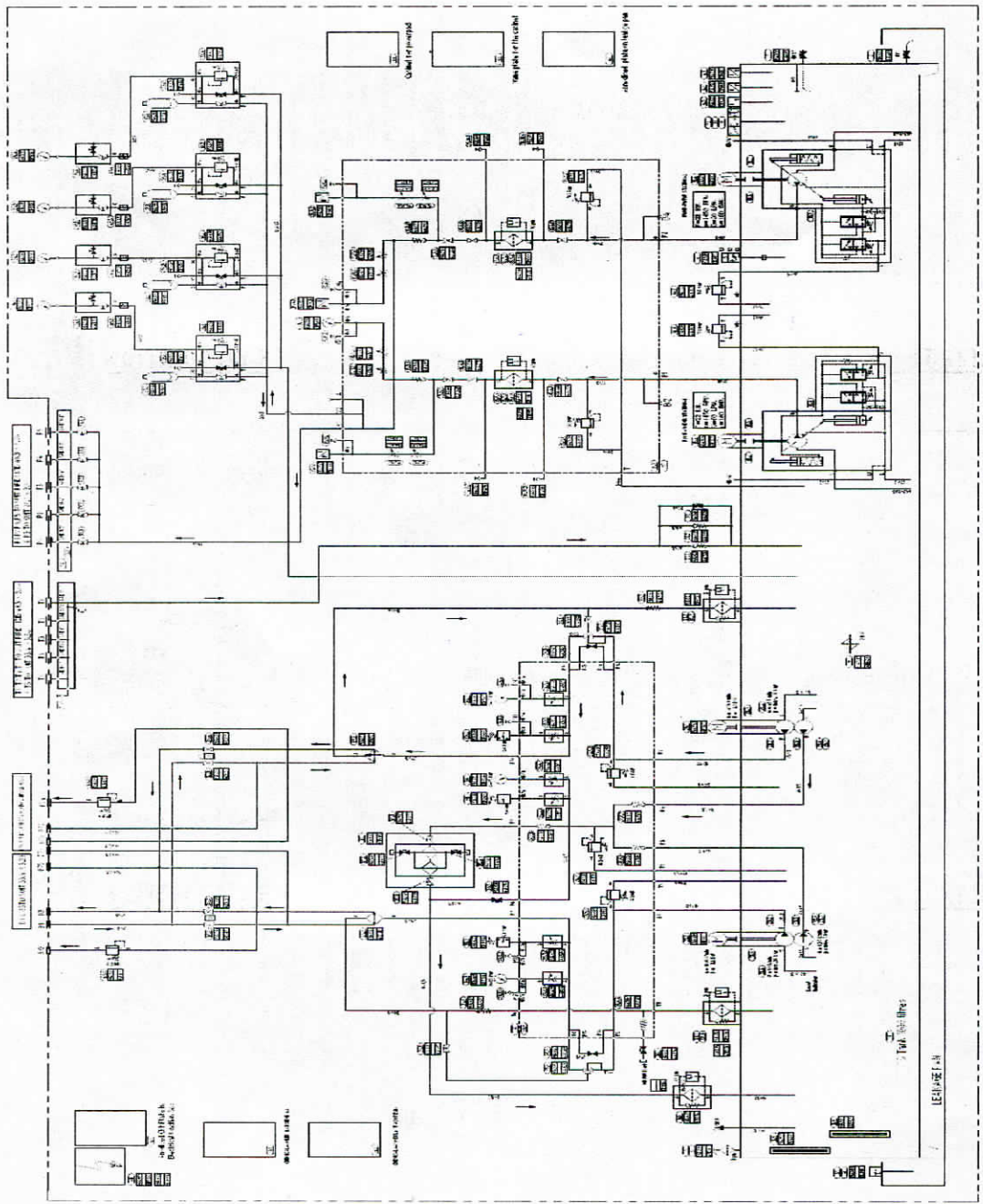

BHEL HARIDWAR

Transmittal, reproduction, dissemination and/or editing of this document as well as utilization of its contents and communication thereof to others without express authorization are prohibited. Offenders will be held liable for payment of damages. All rights created by patent grant or registration of a utility model or design patent are reserved.

i.	Item/Scope of Sub-contracting उप-संविदा(अनुबंध) का मद/ दायरा	
ii.	Address of the registered office पंजीकृत कार्यालय का पता	Details of Contact Person संपर्क व्यक्ति का विवरण <i>(Name, Designation, Mobile, Email)</i> (नाम, पदनाम, मोबाइल, ईमेल)
iii.	Name and Address of the proposed Sub-vendor's works where item is being manufactured प्रस्तावित उप-विक्रेता के कार्यों का नाम और पता, जहां मद का निर्माण किया जा रहा है	Details of Contact Person: संपर्क व्यक्ति का विवरण <i>(Name, Designation, Mobile, Email)</i> (नाम, पदनाम, मोबाइल, ईमेल)
iv.	Annual Production Capacity for proposed item/scope of sub-contracting उप-संविदा(अनुबंध) के प्रस्तावित मद / दायरे के लिए वार्षिक उत्पादन क्षमता	
v.	Annual production for last 3 years for proposed item/scope of sub-contracting उप-संविदा(अनुबंध) के प्रस्तावित मद / दायरे के लिए पिछले 3 वर्षों का वार्षिक उत्पादन	
vi.	Details of proposed works प्रस्तावित कार्यों का विवरण	
1.	Year of establishment of present works वर्तमान फैक्टरी की स्थापना का वर्ष	
2.	Year of commencement of manufacturing at above works उपरोक्त फैक्टरी में निर्माण कार्य शुरू होने का वर्ष	
3.	Details of change in Works address in past (if any पूर्व में फैक्टरी स्थल में परिवर्तन का विवरण (यदि कोई हो))	
4.	Total Area कुल क्षेत्र Covered Area शामिल क्षेत्र	
5.	Factory Registration Certificate फैक्टरी पंजीकरण प्रमाण पत्र	Details attached at Annexure – F2.1 विवरण अनुलग्नक- एफ 2.1 पर संलग्न है
6.	Design/ Research & development set-up डिजाइन / अनुसंधान और विकास सेटअप <i>(No. of manpower, their qualification, machines & tools employed etc.)</i> (श्रमिकों की संख्या, उनकी योग्यता, मशीन और उपलब्ध उपकरण आदि)	Applicable / Not applicable if manufacturing is as per Main Contractor/purchaser design Details attached at Annexure – F2.2 <i>(if applicable)</i> लागू / लागू नहीं, अगर विनिर्माण मुख्य संविदाकार / खरीददार के डिजाइन के अनुसार है)

		विवरण अनुलग्नक -एफ 2.2 पर संलग्न है । (यदि लागू हो)
7.	Overall organization Chart with Manpower Details (Design/Manufacturing/Quality etc) मैनपावर विवरण के साथ समग्र संगठन का चार्ट(डिजाइन / विनिर्माण / गुणवत्ता आदि)	<i>Details attached at Annexure – F2.3</i> विवरण अनुलग्नक – F2.3 में संलग्न है ।
8.	After sales service set up in India, in case of foreign sub-vendor(Location, Contact Person, Contact details etc.) भारत में बिक्री सेवा की स्थापना के बाद, विदेशी उप-विक्रेता के मामले में(स्थल , संपर्क व्यक्ति, संपर्क विवरण आदि)	<i>Applicable / Not applicable</i> लागू / लागू नहीं <i>Details attached at Annexure – F2.4</i> विवरण अनुलग्नक -2.4 पर संलग्न है ।
9.	Manufacturing process execution plan with flow chart indicating various stages of manufacturing from raw material to finished product including outsourced process, if any फ्लोचार्ट सहित विनिर्माण प्रक्रिया निष्पादन योजना , जिसमें आउटसोर्स प्रक्रिया, यदि कोई हो, सहित कच्चे माल से तैयार उत्पाद तक विनिर्माण के विभिन्न चरणों को दर्शाया गया हो,	<i>Details attached at Annexure – F2.5</i> विवरण अनुलग्नक - F2.5में संलग्न है ।
10.	Sources of Raw Material/Major Bought Out Item कच्चे माल के स्रोत / खरीदे हुए मुख्य मद	<i>Details attached at Annexure – F2.6</i> विवरण अनुलग्नक - F2.6में संलग्न है।
11.	Quality Control exercised during receipt of raw material/BOI, in-process , Final Testing, packing कच्चे माल / खरीदे हुए मद, प्रक्रियाबद्ध, अंतिम परीक्षण, पैकिंग करते समय गुणवत्ता नियंत्रण	<i>Details attached at Annexure – F2.7</i> विवरण अनुलग्नक - F2.7 पर संलग्न है
12.	Manufacturing facilities (List of machines, special process facilities, material handling etc.) विनिर्माण सुविधा(मशीनों की सूची , विशेष प्रक्रिया सुविधाएं, सामग्री रख-रखाव आदि)	<i>Details attached at Annexure – F2.8</i> विवरण अनुलग्नक - F2.8में संलग्न है ।
13.	Testing facilities (List of testing equipment) परीक्षण सुविधाएं(परीक्षण उपकरण की सूची)	<i>Details attached at Annexure – F2.9</i> विवरण अनुलग्नक – F2. 9 में संलग्न है ।
14.	If manufacturing process involves fabrication then- यदि निर्माण प्रक्रिया में फेब्रिकेशन की गई है तो- List of qualified Welders पात्र वेल्डर की सूची List of qualified NDT personnel with area of specialization विशेषज्ञता के क्षेत्र सहित पात्र एनडीटी कार्मिकों की सूची	<i>Applicable / Not applicable</i> लागू / लागू नहीं <i>Details attached at Annexure – F2.10</i> विवरण अनुलग्नक - F2.10में संलग्न है। (if applicable) लागू / लागू नहीं
15.	List of out-sourced manufacturing processes with Sub-Vendors' names & addresses सब-वेंडर द्वारा बाह्य स्रोतों	<i>Applicable / Not applicable</i> लागू / लागू नहीं



CORPORATE QUALITY ASSURANCE/ कॉर्पोरेट गुणवत्ता आश्वासन

SUB-VENDOR QUESTIONNAIRE/ सब-वेंडर प्रश्नावली

	(उनके नाम और पते सहित)से करवाएं गए निर्माण प्रक्रियाओं की सूची	<i>Details attached at Annexure. –F2.11</i> विवरण अनुलग्नक - F2.10में संलग्न है। (if applicable) (यदि लागू हो)			
16.	<i>Supply reference list including recent supplies</i> नवीनतम आपूर्ति सहित आपूर्ति संदर्भ सूची	<i>Details attached at Annexure – F2.12</i> विवरण अनुलग्नक - F2.12 में संलग्न है। (as per format given below) (नीचे दिए गए प्रारूप के अनुसार)			
<i>Project/ package</i> परियोजना /पैकेज	<i>Customer Name</i> ग्राहक का नाम	<i>Supplied Item (Type/Rating/Model /Capacity/Size etc)</i> आपूर्ति की गई वस्तु (प्रकार / रेटिंग / मॉडल / क्षमता / आकार आदि)	<i>PO ref no/date</i> पीओ संदर्भ सं. / तिथि	<i>Supplied Quantity</i> आपूर्ति की मात्रा	<i>Date of Supply</i> आपूर्ति की तारीख
17.	<i>Product satisfactory performance feedback letter/certificates/End User Feedback</i> उत्पाद के संतोषजनक प्रदर्शन संबंधी फीडबैक पत्र / प्रमाण पत्र / अंतिम उपयोगकर्ता फीडबैक		<i>Attached at annexure - F2.13</i> अनुलग्नक F2. 3पर संलग्न है		
18.	<i>Summary of Type Test Report (Type Test Details, Report No, Agency, Date of testing) for the proposed product (similar or higher rating)</i> प्रस्तावित उत्पाद (एक समान या उच्च रेटिंग वाले) के लिए टाइप टेस्ट रिपोर्ट (टाइप टेस्ट विवरण, रिपोर्ट संख्या, एजेंसी, जांच की तारीख) का सारांश नोट:- रिपोर्ट प्रस्तुत करने की आवश्यकता नहीं है <i>Note:- Reports need not to be submitted</i>		<i>Applicable / Not applicable</i> लागू / लागू नहीं <i>Details attached at Annexure – F2.14</i> विवरण अनुलग्नक - F2.1 4में संलग्न है (if applicable) (यदि लागू हो)		
19.	<i>Statutory / mandatory certification for the proposed product</i> प्रस्तावित उत्पाद के लिए वैधानिक / अनिवार्य प्रमाणीकरण		<i>Applicable / Not applicable</i> लागू / लागू नहीं <i>Details attached at Annexure – F2.15</i> (if applicable) (यदि लागू हो)		
20.	<i>Copy of ISO 9001 certificate</i> आईएसओ 9001 प्रमाण पत्र की प्रति (if available)(यदि उपलब्ध हो)		<i>Attached at Annexure – F2.16</i> अनुलग्नक में संलग्न - F2.1 6 है		
21.	<i>Product technical catalogues for proposed item (if available)</i> प्रस्तावित मद के लिए उत्पाद तकनीकी कैटलॉग (यदि उपलब्ध हो)		<i>Details attached at Annexure – F2.17</i> विवरण अनुलग्नक - F2.1 7 में संलग्न है		
<i>Name:</i> नाम:		<i>Desig:</i> पद:		<i>Sign:</i> हस्ता क्षर:	<i>Date:</i> तिथि:

Company's Seal/Stamp:- कंपनी की मुहर/ मोहर: -

Buyer Specific Special Terms and conditions (In addition to GTC & ATC of GeM)**Item name: HPSU WITH SPARES, Project: 2X660 MW Talcher project****A. SCOPE OF ENQUIRY**

E-bids on GeM are invited from bidders for the supply of **HPSU WITH SPARES** for Talcher project as per requirement mentioned below:

Sl. No.	Project	Material Code	Item Description	Total Quantity	Delivery Schedule
1.	Talchar Unit-1 Project	W90311400299 DRG: 11140030500 REV: 00	HPSU WITH FLUSHING DEVICE, COMMISSIONING SPARES AND ACCESSORIES-MAIN TURBINE VALVES	01 Set	27.02.2025
2.	Talchar Unit-2 Project	W90311400299 DRG: 11140030500 REV: 00	HPSU WITH FLUSHING DEVICE, COMMISSIONING SPARES AND ACCESSORIES-MAIN TURBINE VALVES	01 Set	27.06.2025
3.	Talchar Project	W99311400483 DRG: 21140056020 VAR.01 REV: 01	MAIN CONTROL FLUID PUMP ALONG WITH MOTOR & COUPLING COMPLETE ASSEMBLY)	01 No	27.11.2025
4.	Talchar Project	W99311400580 DRG: 21140056020 VAR.11 REV: 01	FILTER ELEMENT ALONG WITH O-RINGS/GASKETS ETC. FOR FILTER IN REGENERATION CIRCUIT	02 ST	27.11.2025
5.	Talchar Project	W99311400890 DRG: 21140056020 VAR.42 REV: 01	MOLECULAR SIEVE AND ION EXCHANGER AMBERLYIST FOR REGENERATION VESSEL (COMPLETE REPLACEMENT IN HPSU)	02 ST	27.11.2025
6.	Talchar Project	W99311400564 DRG: 21140056020 VAR.09 REV: 01	FILTER ELEMENT ALONG WITH O-RINGS/GASKETS ETC. FOR FILTER IN MAIN LINE (160 BAR)	01 ST	27.11.2025
7.	Talchar Project	W99311400602 DRG: 21140056020 VAR.13 REV: 01	FILTER ELEMENT ALONG WITH O-RINGS/GASKETS ETC. FOR FILTER IN COOLING CUM FILTRATION CIRCUIT	01 ST	27.11.2025
8.	Talchar Project	W99318146205 DRG: 418000C8052 REV:00	PRESSURE TRANSMITTER FOR MAIN HPSU	01 NO	27.11.2025
9.	Talchar Project	W99318146191 DRG: 418000C8052 REV:00	LEVEL TRANSMITTER FOR MAIN HPSU	01 NO	27.11.2025
10.	Talchar Project	W99318146213 DRG: 418000C8052 REV:00	RTD FOR MAIN HPSU	01 NO	27.11.2025
11.	Talchar Project	W99318146140 DRG: 418000C8052 REV:00	PRESSURE SWITCH FOR MAIN HPSU	2 NOS	27.11.2025
12.	Talchar Project	W99318146159 DRG: 418000C8052 REV:00	DIFFERENTIAL PRESSURE SWITCH TYPE-1 FOR MAIN HPSU	02 NOS	27.11.2025
13.	Talchar Project	W99318146167 DRG: 418000C8052 REV00	DIFFERENTIAL PRESSURE SWITCH TYPE-2 FOR MAIN HPSU	02 NOS	27.11.2025
14.	Talchar Project	W99318146175 DRG: 418000C8052 REV:00	DIFFERENTIAL PRESSURE SWITCH TYPE-3 FOR MAIN HPSU	02 NOS	27.11.2025
15.	Talchar Project	W99318146132 DRG: 418000C8052 REV:00	LEVEL GAUGE FOR MAIN HPSU	02 NOS	27.11.2025
16.	Talchar Project	W99318146094 DRG: 418000C8052 REV:00	PRESSURE GAUGE TYPE-1 FOR MAIN HPSU	02 NOS	27.11.2025
17.	Talchar Project	W99318146108 DRG: 418000C8052 REV:00	PRESSURE GAUGE TYPE-2 FOR MAIN HPSU	02 NOS	27.11.2025

Buyer Specific Special Terms and conditions (In addition to GTC & ATC of GeM)**Item name: HPSU WITH SPARES, Project: 2X660 MW Talcher project**

18.	Talchar Project	W99318146116 DRG: 418000C8052 REV:00	PRESSURE GAUGE TYPE-3 FOR MAIN HPSU	02 NOS	27.11.2025
19.	Talchar Project	W99318146124 DRG: 418000C8052 REV:00	PRESSURE GAUGE TYPE-4 FOR MAIN HPSU	02 NOS	27.11.2025

. B. Buyer Specific Special Terms and Conditions:

Sl. No.	Terms	Description	Bidder's confirmation
1.	Compliance of GTC on GeM	In addition to the terms & conditions mentioned in below table, General Terms and Conditions on GeM 4.0 (Version 1.10) Dt. dt 31 st March 2023 or it's latest revision (if revised prior to issuance of enquiry) shall be applicable against this enquiry. Kindly confirm same is acceptable to you.	
2.	Documents Checklist:	<p>Please submit signed and stamped copy of your offer on each page along with following documents;</p> <ul style="list-style-type: none"> • Buyer Specific T&C. • Technical PQR & its supportive document. • Technical drawing & purchase specification. • Quality plan. • Certificate/self-certification for minimum local content as per PPP-MII order. • EMD submission proof (if, applicable) <p>Please note that technical documents shall be shared against submission of FCA (FCA copy enclosed) .</p>	
3.	Pre-Qualification Requirements	The Pre-Qualification Requirements have been compiled. All the bidders should ensure submission of complete details and documents as called for in these requirements. The Offers submitted by the bidders would be scrutinized with respect to Pre-Qualification Requirements first. Techno-Commercial offer of only those bidders shall be evaluated who meet the Pre-Qualification Requirements.	
4.	EMD submission clause/ exemption condition of EMD	<p>EMD of Rs 200000 is applicable. Proof of EMD submission details must be uploaded on the e-procurement (GeM) portal. Please confirm.</p> <p>The EMD should be submitted in the form of demand draft / Pay Order. The Drafts shall be drawn in favor of "BHEL Hardwar". & the same may be sent to following address</p> <p>To, The Head of Material Management, Heavy Electrical Equipment Plant, Bharat Heavy Electricals Limited, Haridwar-249403 (Uttarakhand), India.</p> <p>EMD in form of e- payment is also acceptable. For E-Payment, the RTGS details are as mentioned below: STATE BANK OF INDIA RANIPUR BRANCH, OPP: BHEL MAIN GATE, SECTOR-5, RANIPUR, HARIDWAR, UTTRAKHAND, INDIA PIN CODE: 249403 SWIFT NO : SBININBB225 CC ACCOUNT NO : 10667995458 IFSC CODE : SBIN0000586</p> <p>Bidders already registered at BHEL Hardwar (i.e. PMD Vendors) for this</p>	

Buyer Specific Special Terms and conditions (In addition to GTC & ATC of GeM)

Item name: HPSU WITH SPARES, Project: 2X660 MW Talcher project

		<p>package are exempted from submission of EMD. MSE suppliers /State Government PSU/Central Government PSU are exempted for submission of EMD. Micro and Small Enterprises (Registered under SSI, NSIC, Khadi Board, DIC etc.) are also exempted from submission of EMD.</p>	
5.	Customer approval requirement	<p>The Kindly note that proneness criteria required by the end-user (NTPC) are mentioned in PQR. Accordingly, the supplier has to submit the filled-Sub-Vendor Questionnaire along with required documents as referred therein to forward the same to the customer for their approval. The supplier approval by the end-user (NTPC) is mandatory for consideration of their offer.</p> <p>Price bid of the offer of only those bidders who meet pre-qualification requirement, proneness criteria , technical requirement and approved by the NTPC will be considered for price bid opening.</p>	
6.	Evaluation criteria	<p>Evaluation shall be done on total landed cost upto respective BHEL Project Site considering all material codes and services together.</p> <p>Services Include: Supervision during Erection & Commissioning and Training.</p>	
7.	Sharing of Drawing:	<p>Bid bidders shall submit endorsed copy of attached FCA to get soft copy of drawings @ gupta.sachin@bhel.in & ssbgapankaj@bhel.in</p>	
8.	Make in India & MSE Purchase Preference guidelines:	<p>Make in India circular Ref. No. P-45021/2/2017-PP (BE-II) dtd. 04/06/2020 and subsequent orders shall be applicable for this procurement and only Class-I local supplier & Class-II local suppliers shall be eligible to bid in procurement. Purchase preference shall be given as per applicable Make in India guidelines and as per functionalities enabled on GeM portal.</p>	
9.	Consignee details	<p>Talchar project consignee details is as follows;</p> <p>NTPC LIMITED, TALCHER TPP, STAGE-III 2X660MW PO TALCHER, DISTT- ANGUL STATE OF ODISHA, PIN 759101</p>	
10.	Bid validity/ Validity of offer	<p>Please note that validity of the offer shall be 180 days from the date opening of Techno-Commercial bid (Part-I bid) on NIC portal. Offer of bidder's having validity less than 180 days shall liable to reject. BHEL reserve the right to reject the offer in case validity of offer less than 180 days. Please confirm.</p>	
11.	Technical Requirement for Talchar Project:	<p>THE VENDOR TO ENSURE COMPLETENESS OF THEIR OFFER AS PER CLAUSE-6 OF BHEL SPECIFICATION DRAWING 11140030500, PRIOR TO SUBMISSION OF THEIR OFFER.</p> <p>ALL THE VENDORS TO ENSURE TO SUBMIT DULY FILLED CHECKLIST AS PER ANNEXURE-C</p> <p>The Vendor to provide 3D models for the supplied equipment assemblies (having all the components included) complete with all connection points/interfaces for the purpose of 3D power plant layout to be done by BHEL as per Customer specification requirements. The file formats of 3D models shall be informed by BHEL and the same shall be subject to Customer approval."</p>	

Buyer Specific Special Terms and conditions (In addition to GTC & ATC of GeM)

Item name: HPSU WITH SPARES, Project: 2X660 MW Talcher project

12.	Basis of quotation:	Prices are to be quoted on FOR destination basis. Kindly confirm that price has been quoted on FOR destination basis i.e. including all taxes, duties, local levies/ transportation / packing & forwarding charges Freight & GST etc. (except insurance charges)	
		Bidder to Confirm that the prices will remain firm during the entire validity and execution of the Project	
		Transit insurance would be arranged by BHEL. Please send your offer keeping this in view.	
13.	GST Rate	Please mention here the applicable GST % rate included in the prices quoted by you.	
14.	SPECIAL INSTRUCTION	<p>Please note that as per BHEL's Policy, we cannot allow Price impact for the requirement / scope of supply, which is a part of specifications of our tender enquiry. Hence please read all specification / documents thoroughly and submit your offer as per specifications of tender enquiry.</p> <p>In case of any confusion / un-clarity on any of the clause / requirement of specification, please clarify the same from BHEL before submission of offer.</p> <p>No deviation & request regarding un-clarity / contradictory conditions / ambiguity of specifications would be entertained after opening of techno-commercial offers. Further no price impact would be allowed for the requirement which is already part of the specifications of the tender enquiry, after opening of techno-commercial offers.</p> <p>Please note and confirm.</p>	
15.	Engineering Document/ Document approval	Please quote your valuable offer as per BHEL documents, drawings, specifications etc. as per the tender enquiry.	
		<p>Technical documents/ drawings required with the offer</p> <p>Please ensure completeness of your offer as per Annexure–IIA & IIB (copy enclosed). Checklist (i.e. Annexure - IIA & IIB) duly filled in, shall be submitted along with the offer.</p>	
		THE DOC. "CIE-HPSU-G3 REV00" IS PART OF THE PURCHASE SPECIFICATIONS AND SHALL BE COMPLIED BY THE VENDORS.	
		<p>Documents required after order placement:</p> <p>IN THE EVENT OF ORDERING THE VENDOR SHALL FURNISH ALL THE DOCUMENTS AS PER DRG. NO. 41140056014 (MASTER DOCUMENTS LIST) COMPLYING TIME SCHEDULE REFERRED THERE IN.</p>	
		Drawings/Data sheets/documents & Quality plan as called for in the specifications/Drawings/Documents shall be submitted for approval to BHEL for BHEL/customer approval within 30 days of purchase order. Any delay in delivery on account of late submission of drawings shall be to vendors account. BHEL will arrange the approval of the drawings/data sheets/ documents within 30 days of their receipt provided those are complete in all respect. Any delay in documents submission/approval shall be on either side.	
		HPSU documents submitted by vendor for BHEL's approval shall also be subject to customer's approval. Therefore timely submission of the complete set of LPBP system documents must be ensured by the vendor.	

Buyer Specific Special Terms and conditions (In addition to GTC & ATC of GeM)

Item name: HPSU WITH SPARES, Project: 2X660 MW Talcher project

16.	Recommended Spares	Please submit item wise price list of each item referred in BHEL Drawing no 2-11400-56015 REV.01 (Recommended Spare Parts) for Talcher Project .These prices shall be used for our reference and future ordering (if required) and not to be considered for Evaluation.	
17.	Supervision during Erection & Commissioning and Training	<p>Confirm that following charges have been quoted separately in your offer (As per the price schedule):</p> <ol style="list-style-type: none"> 1. Per ManDay Charges for Training, Supervision during Erection & Commissioning (lump sum & inclusive of everything i.e. lodging, fooding, boarding etc.) 2. Per Visit Charges (to & fro to our site) for Training regarding design/construction features, operation & maintenance of the supplied equipments (Including C&I) to customer's/BHEL Engineers, Supervision during Erection & Commissioning. <p>A total period of 14 mandays (Inclusive of 02 days training) and 04 Visits will be taken for evaluation purpose for 02 TG Set. However payment will be made on actual number of man days and visits involved in supervision of erection/ commissioning and training.</p> <p>Please ensure that "Per Man Day" & "Per Visit" charges for Supervision during Erection & Commissioning and Training including every expense are quoted.</p>	
		Kindly note that you have to make a visit of 02-03 days to project site at a suitable point of time during erection, to streamline all the erection & commissioning activities of your supplied equipments and to ensure completeness of all equipments/tools etc., which are required for commissioning of the equipments. This visit is included in the above mentioned 02 visits to be taken for evaluation.	
		Kindly confirm that the quoted Erection, Commissioning & Training charges are inclusive of applicable GST .	
		Please note that the vendor should send a checklist to BHEL prior to deputation of Site Engineer for Commissioning. BHEL will confirm the checklist prior to issuing Commissioning Call to the vendor. After receipt of checklist from BHEL, the vendor should send the commissioning Engineer within 15 days of confirmation of site readiness. In case, any additional work is required which is beyond the scope / warranty, the work should be commenced only after signed agreements with site representative & the vendor.	
18.	Penalty / LD Clause	Liquidated Damages for late delivery w.r.t to contractual delivery shall be applicable @ 0.5% of the "Basic Material Value of each lot" per week of delay or part thereof subject to a maximum of 10% of the "BASIC Material Value of each lot" . LD is applicable lotwise.	
		The date of LR (Lorry Receipt) would be treated as the date of delivery for penalty purposes	
19.	Risk Purchase:	In case of abnormal delays (beyond the maximum late delivery period as per LD clause) in supplies / defective supplies or non-fulfillment of any other terms and conditions given in Purchase Order, BHEL may cancel the Purchase Order in full or part thereof, and may also make the purchase of such material from elsewhere / alternative source at the risk and cost of the supplier. BHEL will take all reasonable steps to get the material from	

Buyer Specific Special Terms and conditions (In addition to GTC & ATC of GeM)

Item name: HPSU WITH SPARES, Project: 2X660 MW Talcher project

		alternate source at optimum cost. If bidder does not agree to the above Risk Purchase Clause, BHEL reserves the right to reject the offer. In case for compelling reasons BHEL accepts the offer without acceptance of this clause by the bidder and in the eventuality of Risk Purchase, appropriate action will be taken as per BHEL extant rules. This will be without prejudice to any other right of BHEL under the contract or under General Law.									
20.	Action against Bidders / vendor / supplier / contractor in case of default	<p>In order to protect the commercial interests of BHEL, BHEL shall take action against supplies / contractors by way of suspension of business dealings, who either fail to perform or are in default without any reasonable cause, cause loss of business/ money/ reputation, indulge in malpractices, cheating, bribery, fraud or any other misconduct or formation of cartels so as to influence the bidding process or influence the price etc.</p> <p>Suspension of Business Dealings could be in the form of “Hold” or “Banning” a supplier/ contractor or a bidder and shall be as per “Guidelines for Suspension of Business Dealings with Suppliers/ Contractors” available at BHEL’s website “https://www.bhel.com/guidelines-suspension-business-dealings-supplierscontractors”</p>									
21.	Compliance of 144 (xi) of GFRs-2017	RESTRICTIONS UNDER RULE No. 144 (xi) of GFRs-2017.: ALL PROVISIONS OF ORDER NO. F. NO. 6/18/2019-PPD DTD. 23/07/2020 OF DEPARTMENT OF EXPENDITURE (DOE) SHALL BE APPLICABLE FOR THIS TENDER ENQUIRY (ORDER COPY IS AVAILABLE AT https://doe.gov.in/procurement-policy-divisions).									
22.	Payment Terms	<p>For Material portion :</p> <p>The payment shall be done after issue of consignee receipt-cum acceptance certificate (CRAC) or confirmation of receipt of material at site as per the below details:</p> <table border="1"> <thead> <tr> <th>Type of Bidder</th> <th>Payment Terms (Number of Days)</th> </tr> </thead> <tbody> <tr> <td>Micro & Small Enterprises (MSEs)</td> <td>45 days</td> </tr> <tr> <td>Medium Enterprises</td> <td>60 days</td> </tr> <tr> <td>Non MSME</td> <td>90 days</td> </tr> </tbody> </table> <p>Supervision during Erection, Commissioning and training: 100% Payment against submission of successful Erection/ commissioning/ training certificate (as applicable) from Project Site and invoice thru Bank / direct to BHEL. Payment will be made on actual number of days and visits involved in supervision of commissioning as certified by the project site.</p> <p>Please note that in case of any deviation in the payment terms, BHEL shall evaluate your offer after loading on account of deviation in payment terms as per BHEL practice / policy.</p> <p>Requirement of PBG for Guarantee/ Warranty period is mandatory and non-acceptance of the PBG may lead to rejection of your offer.</p>	Type of Bidder	Payment Terms (Number of Days)	Micro & Small Enterprises (MSEs)	45 days	Medium Enterprises	60 days	Non MSME	90 days	
Type of Bidder	Payment Terms (Number of Days)										
Micro & Small Enterprises (MSEs)	45 days										
Medium Enterprises	60 days										
Non MSME	90 days										
23.	Performance Bank Guarantee	PBG (performance bank guarantee) shall be submitted for 5% of the order value material portion) lotwise. PBG should be valid for entire Guarantee/ Warranty period. PBG shall be submitted for processing of									

Buyer Specific Special Terms and conditions (In addition to GTC & ATC of GeM)

Item name: HPSU WITH SPARES, Project: 2X660 MW Talcher project

		<p>invoices.</p> <p>This should be read and complied in conjunction with Bank Guarantee clause in General Instructions and Standard Term and Conditions for bidding against Tender Enquiry (herein called as GISTC).</p> <p>Lot wise PBG will be acceptable in line with shipment of items</p>	
24.	Quantity Variation	<p>BHEL reserves the right to cancel tender or reject any or all the quotations without assigning any reasons thereof.</p> <p>BHEL also reserves the right to Increase or decrease the tendered quantities or quantity of individual material code may be dropped as a whole also.</p> <p>Vendors should be prepared to accept order for reduced Quantity without any extra charges. Vendor should also be prepared for giving discount in case of Increase in Quantity.</p> <p>Vendor has to take manufacturing clearance from BHEL before starting manufacturing of material. In case ordered quantity is reduced at the time of manufacturing clearance, then payment shall be made accordingly as per decreased quantity. Kindly confirm.</p>	
25.	Arbitration Clause	<p>In case of any dispute arising out of as in connection with this contract, the same shall be referred to arbitration under Arbitration & Conciliation Act 1996 of a sole arbitrator who shall be appointed by mutual consent of the parties. The seat & venue of arbitration shall be Haridwar.</p> <p>The proceedings shall be conducted in English. The Governing law of contract shall be the substantive law of India.</p>	
26.	Force Majeure	<p>Notwithstanding any other thing contained anywhere else in the contract or PO (Purchase Order), In case the discharge of obligation under the contract by either party is impeded or made unreasonably onerous, neither party shall be considered in breach of the contract to the extent that performance of their respective obligation is prevented by an event of Force Majeure that arises after the effective date (PO date).</p>	
27.	Quality Requirement	<ul style="list-style-type: none">• Kindly confirm to submit quality plan in attached format for BHEL & NTPC approval.• QP of the successful vendor shall be forwarded to NTPC for their approval.• Kindly confirm that Inspection shall be done by Third Party Inspection agency INTERTEK & NTPC as per NTPC approved quality plan.• For spares items, inspection shall be done as main customer approved QP. For the items not appearing in customer approved QP, TC/COC to be submitted. <p>Inspection charges will be borne by BHEL. All coordination with third party inspection agency shall be done by the supplier only. Inspection call to third party inspection agency may be raised directly by the supplier; however 15 days are to be provided for deputation of representative of third party inspection agency for inspection.</p>	
28.	Material verification	<p>The supplier shall depute their representative to site after receipt of material at a suitable point of time to carrying out material verification in</p>	

Buyer Specific Special Terms and conditions (In addition to GTC & ATC of GeM)

Item name: HPSU WITH SPARES, Project: 2X660 MW Talcher project

		presence of BHEL site re-representative , in order to check completeness of supplied equipment. The boxes/ consignment received from supplier will be opened in front of supplier’s representative and the content of the packages would be inspected jointly w.r.t. detailed packing list. Any shortage or physical damage shall be identified and recorded in the minutes to be signed with Site/ BHEL Hardwar's representative. Supplier shall depute their representative for this activity within 10 days of receipt of intimation from BHEL without any additional cost.	
29.	MDCC Clause	Please confirm that material shall be dispatched only after issue of MDCC from BHEL. The Test Certificates/Inspection reports/COC/Interchangeability Certificate as per approved quality plan shall be submitted to BHEL for review and acceptance before dispatch of Material. The Material Dispatch Clearance (MDCC) will be provided by BHEL within 07 days of receipt of documents, provided those are complete in all respects. Material shall be dispatched within one week of issue of MDCC (material dispatch clearance certificate) by BHEL.	
30.	Guarantee/Warranty	Kindly confirm the following Guarantee/Warranty clause; <ul style="list-style-type: none"> • Standard Guarantee/Warranty period shall be provided for a period of 36 months from the date of supply or 18 months from commissioning, whichever is earlier. In case of any failure or trouble reported from site, the supplier should depute their representative immediately to attend the problem and replace the defective component/part if required, without any additional cost to BHEL. • Minimum acceptable criteria of Guarantee/Warranty shall be 30 months from the date of supply or 12 months from the date of commissioning. • The supplier to provide technical support/services or alternative solutions against any issues; reported in the equipment supplied by the vendor for up to at least 10 years from the supply date. • Offers with guarantee/Warranty period lesser than above mentioned guarantee period will result in rejection of the offer. 	
31.	O&M Manuals	Kindly confirm that in the event of ordering O&M manuals will be provided in 22 nos. of Hard Copies and 07 CD ROMs as per AT BHEL HARDWAR AS PER CLAUSE 2.4.1 OF BHEL DRG. NO. 1-11400-56012 . 03 NOS of hard copies & 01 CD ROM of O&M Manuals shall be supplied along with the equipment and description of the same should be mentioned in packing list.	
		THE VENDOR TO NOTE THAT VENDOR'S DOCUMENTS INCLUDING O&M MANUAL SHALL BEAR THE DETAILS AS PER COVER PAGE (ANNEXURE-IV). FURTHER THE COVER PAGE OF THE O&M MANUAL SHALL BE BILINGUAL IN HINDI AND ENGLISH LANGUAGE	
32.	Packing and Storage	Kindly confirm the following packing & storage requirements; <ul style="list-style-type: none"> • All the equipments/items shall be supplied in closed steel boxes/closed wooden boxes with steel cover sheet. packing boxes should be rain proof. Kindly confirm. • Packaging of item should be done in such a way that it should not require any internal package inspection for at least one year. • Packing box of mandatory spares shall be painted with green 	

Buyer Specific Special Terms and conditions (In addition to GTC & ATC of GeM)

Item name: HPSU WITH SPARES, Project: 2X660 MW Talcher project

		<p>color for easy identification at project site.</p> <ul style="list-style-type: none">• All the equipments /items shall be dispatched in seaworthy packing as per packing instruction document no. HW0232898.• STORAGE & HANDLING INSTRUCTIONS OF THE EQUIPMENTS SHALL BE FURNISHED BY THE VENDOR SEPARATELY AND 2 COPIES OF THE SAME SHALL BE SUPPLIED TO SITE ALONG WITH MAIN EQUIPMENTS.	
33.	Special Instructions:-	For Talchar Projects: - <ol style="list-style-type: none">1. Before shipment of material, vendor has to obtain QR code from BHEL and these QR codes (properly laminated) shall be affixed on package/boxes/crates/bundles of material to be supplied. while packing the material following is to be ensured.2. Material of Unit-1, Unit-2 and Mandatory Spares need to be packed in separate boxes.3. Loos items (if any) need to be packed in boxes/crates or bundled together. For loose items one marker board needs to be send for each bundle for affixing RFID tag at Site.4. QR code will be issued "Box wise/ bundle wise" vendor to ensure correct QR box are affixed on the boxes/bundles.	
34.	Order Acceptance :	Ink signed order acceptance shall be furnished within 15 days of order placement. In case, order acceptance do not received within 15 days of order placement, PO deemed to be accepted by you.	
35.	Beneficiary of PO	Kindly confirm on whom the PO will be placed in the event of ordering.	
36.	Delivery	Bidders are requested to offer best possible delivery (project/Lotwise) from PO placement. Early delivery wrt enquiry deliveries shall not be accepted. In such cases PO will be placed with enquiry delivery. Please confirm	
37.	Technical Requirements	Please confirm technical requirement of product as per BHEL drawing , purchase specifications & PQR enclosed.	
38.	Additional Conditions for Assessment	BHEL reserves the right to consider / Not-consider the offers based on the evaluation of documents submitted for the Pre-Qualification Criteria (PQR). BHEL also reserves the right to have on-site assessment of the facilities at supplier's works during the bid evaluation.	

SPECIAL NOTE FOR BIDDERS:

Following documents are an integral part of this tender enquiry and endorsed copies of these documents (duly signed and stamped on each page, as a consider of acceptance) are to be uploaded along with offer on e-procurement portal.

1. Please submit replica of Price schedule (without prices) showing "quoted" in place of price along with techno-commercial bid (Part-I).
2. Please submit signed & Stamped copy (each page) of duly filled of confirmation column of "Buyers Specific Additional Terms & Conditions in addition to GTC (Annexure-A)" and its clause wise supporting documents where required.
3. Please submit signed & stamped copy (each page) of General terms and conditions on GeM 4.0 (Version 1.10) along with Tender documents.

Format for Self Certification under preference to Make in India order

Certificate

In line with Government Public Procurement Order No. P-45021/2/2017-PP (BE-II) dated 04.06.2020, we hereby certify that we M/s _____ (supplier name) are local supplier. The percentage of local content in the items _____ offered by us against Enquiry No. _____ is _____% (percentage).

Details of location at which local value addition will be made is as follows:

We also understand, false declarations will be in breach of the Code of Integrity under Rule 175(1)(i)(h) of the General Financial Rules for which a bidder or its successors can be debarred for up to two years as per Rule 151 (iii) of the General Financial Rules along with such other actions as may be permissible under law.

Sign & Stamped of the supplier

BANK GUARANTEE FOR PERFORMANCE SECURITY

Bank Guarantee No:

Date:

To
NAME
& ADDRESSES OF THE BENEFICIARY

Dear Sirs,

In consideration of Bharat Heavy Electricals Limited (hereinafter referred to as the 'Employer' which expression shall unless repugnant to the context or meaning thereof, include its successors and permitted assigns) incorporated under the Companies Act, 1956 and having its registered office at _____¹ through its Unit at.....(name of the Unit) having awarded to (Name of the Vendor / Contractor / Supplier) with its registered office at _____² hereinafter referred to as the 'Vendor / Contractor / Supplier ', which expression shall unless repugnant to the context or meaning thereof, include its successors and permitted assigns), a contract Ref No.....dated³ valued at Rs.....⁴ (Rupees -----)/FC.....(in words.....) for⁵ (hereinafter called the 'Contract') and the Vendor / Contractor / Supplier having agreed to provide a Contract Performance Bank Guarantee, equivalent to% (.... Percent) of the said value of the Contract to the Employer for the faithful performance of the Contract,

we,, (hereinafter referred to as the Bank), having registered/Head office at and inter alia a branch at being the Guarantor under this Guarantee, hereby, irrevocably and unconditionally undertake to forthwith and immediately pay to the Employer any sum or sums upto a maximum amount of Rs -- -----⁶ (Rupees -----) without any demur, immediately on first demand from the Employer and without any reservation, protest, and recourse and without the Employer needing to prove or demonstrate reasons for its such demand.

Any such demand made on the Bank shall be conclusive as regards the amount due and payable by the Bank under this guarantee. However, our liability under this guarantee shall be restricted to an amount not exceeding Rs. _____.

We undertake to pay to the Employer any money so demanded notwithstanding any dispute or disputes raised by the Vendor / Contractor / Supplier in any suit or proceeding pending before any Court or Tribunal, Arbitrator or any other authority, our liability under this present being absolute and unequivocal.

The payment so made by us under this Guarantee shall be a valid discharge of our liability for payment thereunder and the Vendor / Contractor / Supplier shall have no claim against us for making such payment.

We thebank further agree that the guarantee herein contained shall remain in full force and effect during the period that would be taken for the performance of the said Contract/satisfactory completion of the performance guarantee period as per the terms of the Contract and that it shall continue to be enforceable till

all the dues of the Employer under or by virtue of the said Contract have been fully paid and its claims satisfied or discharged.

WeBANK further agree with the Employer that the Employer shall have the fullest liberty without our consent and without affecting in any manner our obligations hereunder to vary any of the terms and conditions of the said Contract or to extend time of performance by the said Vendor / Contractor / Supplier from time to time or to postpone for any time or from time to time any of the powers exercisable by the Employer against the said Vendor / Contractor / Supplier and to forbear or enforce any of the terms and conditions relating to the said Contract and we shall not be relieved from our liability by reason of any such variation, or extension being granted to the said Vendor / Contractor / Supplier or for any forbearance, act or omission on the part of the Employer or any indulgence by the Employer to the said Vendor / Contractor / Supplier or by any such matter or thing whatsoever which under the law relating to sureties would but for this provision have effect of so relieving us.

The Bank also agrees that the Employer at its option shall be entitled to enforce this Guarantee against the Bank as a principal debtor, in the first instance without proceeding against the Vendor / Contractor / Supplier and notwithstanding any security or other guarantee that the Employer may have in relation to the Vendor / Contractor / Supplier 's liabilities.

This Guarantee shall remain in force upto and including.....⁷ and shall be extended from time to time for such period as may be desired by Employer.

This Guarantee shall not be determined or affected by liquidation or winding up, dissolution or change of constitution or insolvency of the Vendor / Contractor / Supplier but shall in all respects and for all purposes be binding and operative until payment of all money payable to the Employer in terms thereof.

Unless a demand or claim under this guarantee is made on us in writing on or before the⁸we shall be discharged from all liabilities under this guarantee thereafter.

We, BANK lastly undertake not to revoke this guarantee during its currency except with the previous consent of the Employer in writing.

Notwithstanding anything to the contrary contained hereinabove:

- a) The liability of the Bank under this Guarantee shall not exceed.....⁶
- b) This Guarantee shall be valid up to⁷
- c) Unless the Bank is served a written claim or demand on or before _____⁸ all rights under this guarantee shall be forfeited and the Bank shall be relieved and discharged from all liabilities under this guarantee irrespective of whether or not the original bank guarantee is returned to the Bank.

We, _____ Bank, have power to issue this Guarantee under law and the undersigned as a duly authorized person has full powers to sign this Guarantee on behalf of the Bank.

For and on behalf of
(Name of the Bank)

Dated.....

Place of Issue.....

Framework Confidentiality Agreement cum Undertaking

This Agreement made on this the _____ day of (month) _____ 20____ (“Effective Date”) by and between
M/s BHARAT HEAVY ELECTRICALS LIMITED, having registered office at “BHEL House”, Siri Fort, New Delhi – 110049 (India), acting through its _____ Unit (hereinafter may be referred to as “BHEL” or “the Company”).

And

M/s _____ (address) _____
represented by authorized representative Sri _____ (herein after referred to as the “Supplier”).

The Supplier and the Company may, unless the context otherwise requires, hereinafter be collectively referred to as “Parties” or singly as the “Party”.

RECITALS

Whereas, BHEL is engaged in the design, engineering, manufacturing, construction, testing, commissioning and servicing of a wide range of products, systems and services for the core sectors of the economy, viz. Power, Transmission, Industry, Transportation, Renewable energy, Oil & Gas and Defence and providing associated services to varied customers in relation to which BHEL/its affiliates own valuable information of a secret and confidential nature.

Whereas the Company may, in connection with Contract(s) (as defined hereunder) placed or to be placed upon the Supplier, or otherwise, from time to time, make available, Technical Information as is defined hereunder.

And Whereas BHEL is willing to provide such Technical Information to the Supplier from time to time and the Supplier understands and acknowledges that such Technical Information is valuable for the Company and as such is willing to protect confidentiality of such information, subject to the terms and conditions set out hereunder.

Now therefore, in view of the foregoing premises and in consideration of the mutual covenants and agreements hereinafter set forth, the Parties agree as under:

1. Definitions:

Unless the context so requires, in this Agreement, the following terms will bear the meaning ascribed to the said term in this clause.

- A. **“Contract”** means the Contract entered into with a Supplier and includes a Purchase Order, or a Work Order for procurement of any goods or for provision of any services.
- B. **“Effective Date”** means the date of this Agreement as mentioned in the preamble of this Agreement.

- C. **“Supplier”** includes a Contractor or a Vendor of the Company whether for supplying of goods or for providing any services under a Contract or both.
 - D. **“Technical Information”** includes Drawings, and/or Product Standards and/or Specifications and/or Corporate / Plant Specifications and/or Technological Process Sheets and/or Technical Data Sheets and/or Jigs & Fixtures and/or Pattern & Dies and/or Special Gauges and/or Tools etc. belonging to or wherein the Company has acquired from a third party a right of user and includes any improvement thereto from time to time whether carried out by the Company or by the Supplier.
 - E. **“Intended Purpose”** means the purpose for which the Technical Information is provided to the Supplier under or in connection with a Contract.
 - F. **“Improvement”** includes any modification made to, or adaptation of, the Technical Information which enhances or is calculated to enhance the performance (whether in terms of effectiveness or in terms of efficiency or both) of the product and/or the service to be provided by the Supplier under a Contract.
2. This Agreement shall come into force/deemed to have come into force, as the case may be, on the Effective Date; or, on the first date when the Technical Information or any part thereof is provided by BHEL to the Supplier; whichever is earlier.
3. **Agreement deemed to be incorporated in each Contract:** Unless and to the extent otherwise stipulated in the Contract, the conditions of this Agreement are deemed to be incorporated in all Contracts which may be entered into between the Company and the Supplier. Further, unless otherwise stipulated, the obligations under this Agreement are and will be independent of the obligations under the Contracts and such obligations of the Supplier hereunder will remain of full effect and validity notwithstanding that the period of validity of the Contracts has expired by efflux of time stipulated therein; or, the contract has been discharged by performance or breach; or, the termination of the Contracts for any reason whatsoever.
4. **Ownership:**
- 4.1 The Company may, from time to time, make available to the Supplier, Technical Information on a non-exclusive basis by way of loan.
 - 4.2 The Supplier acknowledges and agrees that all Technical Information and copies thereof that are or may be provided by the Company to the Supplier, are and shall remain the property of BHEL or that of the concerned entity from whom BHEL has obtained the Technical Information and such Technical Information are and shall constitute trade secrets of the BHEL. Nothing in this Agreement or in any disclosures made hereunder by or on behalf of the Company shall be construed as granting upon the Supplier any patent, copyright or design or any other intellectual property rights of whatsoever description that subsists or may hereinafter exist in the Technical Information. Furthermore, nothing in this Agreement or in any disclosures made hereunder by or on behalf of the Company shall be construed as granting upon the Supplier any license or rights of use of such patent, copyright or design or any other

intellectual property rights of whatsoever description which may now or hereafter exist in the Technical Information except for use of the Technical Information strictly in accordance with this Agreement and the Contract and/or as directed in writing by the Company, solely for the Intended Purpose under the Contract.

- 4.3 Neither Party is obligated by or under this Agreement to purchase from or provide to the other Party any service or product and that any such purchase/sale of any product and/or service by one Party to the other Party will be governed by the Contract if any, that may be entered into by and between the Company and the Supplier.
- 4.4 The Supplier is/has been made well aware and acknowledges that the Technical Information being/which may be shared with it by the Company has been either generated by the Company by incurring huge investment and cost or obtained from foreign collaborators under Technical Collaboration Agreement (TCA) with stringent confidentiality conditions.
- 4.5 The Supplier agrees and undertakes to adhere to confidentiality requirements as applicable to BHEL under a TCA and also ensure that the confidentiality requirements are adhered to by all its concerned employees or sub-contractors/suppliers (where permitted to be engaged by BHEL). Any damages, losses, expenses of any description whatsoever, arising out of or in connection with a breach of the confidentiality requirements under a TCA owing to any act or omission on the part of the Supplier or its employees or sub-contractors/suppliers that is claimed by a foreign collaborator from the Company shall be wholly borne by the Supplier and it shall keep BHEL fully indemnified in this behalf. The demand by the Company shall be conclusive upon the Supplier who shall thereupon forthwith pay to the Company without demur, dispute or delay the amount as demanded without demanding any further proof thereof.
- 4.6 The Supplier agrees and undertakes that unless so decided and advised by the Company in writing all rights/title to any Improvement to the Technical Information shall vest in the Company. The Supplier undertakes and agrees to inform forthwith to the Company of any such Improvement made to the Technical Information and transfer all drawings/documents or other materials connected with such Improvement to the Company and also agrees to fully cooperate with the Company for protecting the Company's interests in such Improvement in the Technical Information including but not limited to obtaining necessary protection for the intellectual property rights in such improvement, if so desired by the Company. If a question arises whether a modification amounts to Improvement to the Technical Information, the same shall be decided by the Company and such decision shall be final and binding upon the Supplier.

5. Use and Non-Disclosure:

- 5.1 Unless otherwise stipulated by the Company, all Technical Information made available to the Supplier, by the Company shall be treated as Confidential irrespective of whether the same is marked or otherwise denoted to be Confidential or not.

- 5.2 The Supplier undertakes and agrees that the Technical Information in its possession shall be held in strict confidence and will be used strictly in accordance with this Agreement and solely for the Intended Purpose under the Contract. Use of the Technical Information for any other purpose other than Intended Purpose is prohibited.
- 5.3 In particular, the Supplier shall not use Technical Information or any Improvement in its possession for the manufacture or procurement of the Product(s) or components or parts thereof or use the Technical Information or any portion thereof or any modification or adaptation thereof in any form to provide any product and/or service to any third party, without the prior written consent of the Company.
- 5.4 The Supplier shall not disclose any of such Technical Information to any third party without the prior written consent of the Company. The Supplier agrees that without prior written consent of the Company, the Supplier shall not disclose to a third party about the existence of this Agreement, or of the fact that it is/was in possession of or has experience in the use of any Technical Information nor shall the Supplier share in any manner whatsoever, with a third party, the name or details of any Contract(s) awarded by the Company to it or performed by the Supplier or the scope of work thereof or share any document or correspondence by and between the Company and the Supplier in or in connection with this Agreement or such Contract(s). Notwithstanding what is stated elsewhere, the overall responsibility of any breach of the confidentiality provisions under this Agreement shall rest with the Supplier.
- 5.5 The Supplier undertakes and agrees not to make copies or extracts of and not to disclose to others any or all of the Technical Information in its possession, except as follows:
- (a) The Supplier may disclose the Technical Information to such of its officers and employees strictly to the extent as is necessary for such officer or employee for the Intended Purpose, provided that the Confidential Information (or copies thereof) disclosed shall be marked clearly as the confidential and proprietary information of Company and that such officers and employees shall similarly be bound by undertakings of confidence, restricted use and non-disclosure in respect of the Technical Information. The Supplier shall be responsible for any breach of such confidentiality provisions by such officers and employees.
 - (b) With the prior written consent of Company, the Supplier may disclose for the Intended Purpose such Technical Information as is provided for in such consent to such of its professional advisers: consultants, insurers and subcontractors who shall be similarly bound by undertakings of confidence, restricted use and non-disclosure in respect of such Technical Information.
 - (c) The Supplier shall not be prevented to make any disclosure required by (i) order of a court of competent jurisdiction or (ii) any competent regulatory authority or agency where such disclosure is required by law, provided that where the Supplier

intends to make such disclosure, it shall first consult Company and take all reasonable steps requested by it to minimize the extent of the Technical Information disclosed and to make such disclosure in confidence and also shall cooperate with the Company in seeking any protective order or any other remedy from proper authority in this matter.

6. Exceptions:

The obligations of the Supplier pursuant to the provisions of this agreement shall not apply to any Confidential Information that:

- a) was/is known to, or in the possession of the Supplier prior to disclosure thereof by the Company;
- b) is or becomes publicly known, otherwise than as a result of a breach of this agreement by the Supplier.
- c) is developed independently of the Disclosing Party by the Supplier in circumstances that do not amount to a breach of the provisions of this Agreement or the Contract;
- d) is received from a third party in circumstances that do not result in a breach of the provisions of this Agreement.

7. The obligation of maintaining confidentiality of the Technical Information on each occasion, shall subsist for the entire duration during which the Technical Information / equipment is in possession of the Supplier and shall thereafter subsist for a further period of --- years from the date when the complete Technical Information has been returned to the Company and if Technical Information has been returned in portions on different dates then, the period of ---- years will be reckoned from the date when the last portion of the Technical Information has been returned. Notwithstanding the expiry of the confidentiality obligation, the obligation of the Supplier under clause 5.4 shall continue to subsist for a further period of ----- years.

8. Warranties & Undertakings:

a) The Supplier undertakes to ensure the due observance of the undertakings of confidence, restricted use and non-disclosure by its persons to whom it discloses or releases copies or extracts of the Technical Information.

b) The Supplier shall keep the Technical Information or improvement made therein properly segregated and not mix up the same with any other material/documents belonging to him/it or to any other third party.

c) The Supplier further undertakes that he/it shall not hypothecate or give on lease or otherwise alienate or do away with any of the Technical Information and/or equipment of the Company, made available to him/it, and undertakes that he/it shall hold the same as a trustee, in capacity of custodian thereof and use/utilise the same solely for the purpose of executing the Contract awarded by the Company.

d) The Supplier further undertakes that he/it shall return all the equipment and/or Technical Information as far as practicable in the same condition in which the same was made available to him/it by the Company together with any Improvement thereon and the documents connected with such Improvement, to the Company forthwith upon completion of the scope

of work or Contract for which such Technical Information was provided by the Company to it or as directed by the Company together with a confirmation by way of an affidavit or in such manner as directed by the Company that it has not retained any equipment and/or Technical Information/Improvement thereof. In case any such equipment and/or Technical Information or Improvement thereof shall remain in his possession or is not capable of being returned, the retention and use of such Technical Information or Improvement thereto shall continue to be governed by this Agreement.

e) The Supplier undertakes to indemnify the Company for all the direct, indirect and/or consequential losses, damages, expenses whatsoever including any consequential loss of business, profits suffered by the Company owing to breach by the Supplier of its obligations under this Agreement and/or the confidentiality requirements, if any, contained in the Contract and that the Supplier hereby agrees that the decision of the Company in all such or any such matter/s shall be final and binding on the Supplier. On mere written demand of the Company, the Supplier shall forthwith and without demur or delay pay to the Company any such sum as determined by the Company as the amount of loss or damage or expense which has been suffered by the Company. The Supplier agrees that the Company shall be entitled to withhold and appropriate any amount payable to the Supplier under any Contract then existing between the Company and the Supplier, in case the Supplier fails to make payment, in terms of the written demand, within 7 days thereof. Without prejudice to the foregoing actions, in respect to any breach of this Agreement, the Company shall be entitled to take any other action against the Supplier as per applicable laws, the Contract, Company's applicable policies, guidelines rules, procedures, etc.

9. Without prejudice to any other mode of recovery as may be available to the Company for recovery of the amount determined as due as per Clause 8(e) hereinabove, the Company shall have a right to withhold, recover and appropriate the amount due towards such losses, damages, expenses, from any amount due to the Supplier in respect of any other Contract (s) placed on him/it by any department/office/Unit/Division of the said Company.

10. Arbitration & Conciliation:

a) In case amicable settlement is not reached between the Parties, in respect of any dispute
or

difference or claim or controversy arising out of the formation, breach, termination, validity or execution of the Contract(or Agreement) or the respective rights and liabilities of the parties or in relation to interpretation of any provision of the Contract or in any manner touching upon the Contract, then, either Party may, by a notice in writing to the other Party refer such dispute or difference or controversy or claim, (except as to any matters, the decision of which is specifically provided for therein) to the sole arbitration by the arbitrator appointed by Head/In-Charge of the Unit/Division/Region.

b) The Arbitrator shall pass a reasoned award and the award of the Arbitrator shall be final and binding upon the parties to the dispute.

c) Subject as aforesaid, the provisions of Arbitration and Conciliation Act 1996 (India), or other statutory modifications or re enactments thereof and the rules made thereunder and for

the time being in force shall apply to the arbitration proceedings under this clause. The seat of arbitration shall be at ----- **(Insert the name of the city/town of the concerned BHEL Unit/Division).**

d) In case of Contract with Public Sector Enterprise (PSE) or a Government Department, the following shall be applicable:

In the event of any dispute or difference relating to the interpretation and application of the provisions of the Contract, such dispute or difference shall be referred to by either party to the arbitration of one of the arbitrators in the department of public enterprises to be nominated by the Secretary to the Government of India in-charge of the Department of Public Enterprises. The Arbitration and Conciliation Act, 1996 shall not be applicable to arbitration under this clause. The award of the arbitrator shall be binding upon the parties to the dispute, provided, however, any party aggrieved by such award may make further reference for setting aside or revision of the award to the Law Secretary, Department of Legal Affairs, Ministry of Law and Justice, Government of India. Upon such reference the dispute shall be decided by the Law Secretary or the Special Secretary or Additional Secretary when so authorized by the Law Secretary, whose decision shall bind the parties hereto finally and conclusively.

e) Notwithstanding the existence or any dispute or differences and/or reference for the arbitration, the Supplier shall proceed with and continue without hindrance the performance of its obligations under this Contract with due diligence and expedition in a professional manner.

11. Governing Law & Jurisdiction:

This Agreement shall be governed by and be construed as per applicable Indian Laws in force at the relevant time.

Subject to clauses 10(a) and 10(d) hereinabove, all matters in connection with the subject agreement shall be subject to exclusive jurisdiction of Courts situated at -----**(insert the name of the place where the BHEL Unit/Division is located)**

SIGNATURE

WITNESSES

1.

Name

Address:

2.

Name:

Address:

