

समशी सूची संख्या को अधिकारित	SUPERSEDES INVENTORY NO.	<u>AIR EXHAUSTER WITH MOTOR (RADIAL VENTILATOR)</u>	BASED ON BHEL'S OWN EXPERIENCE
------------------------------------	--------------------------------	------------------------------------------------------------	-----------------------------------

1.0 SCOPE :

This specification covers the design, manufacture, performance requirements, testing and supply conditions of Air Exhauster with motor for sucking air steam mixture from gland steam condenser in a thermal power station.

1.1 DESIGNATION :

While raising purchase indent, mention the type (see Table-1, Page-6) e.g. Air Exhauster with Motor - Type A to HE 57008.

2.0 TECHNICAL DATA :

2.1 EXHAUSTER DATA :

2.1.1 Medium to be handled : Air steam mixture

2.1.2 Suction temperature : See Table - 1.

2.1.3 Maximum Temperature : 100 °C

2.1.4 Total pressure : See Table - 1

2.1.5 Flow volume : See Table - 1

2.1.6 Density of air steam mixture : See Table - 1

2.1.7 Housing position : See Figure - 1

2.2 MOTOR DATA:

2.2.1 Rated output : To be indicated by the supplier.

2.2.2 Ambient Temperature : 50 °C

2.2.3 Supply : 415 Volts, 3Phase, 50C /s.

2.2.4 Type of enclosure : Totally enclosed fan cooled

2.2.5 Type of protection : IP 54 (IS:4691)

2.2.6 Mounting : As per figure 1

2.2.7 Starting : Direct on line

2.2.8 Voltage Variation : +/- 10%

Frequency Variation : +/- 5%

Combined voltage & frequency variation : +/- 10%

2.2.9 Insulation Class : B

2.2.10 Efficiency Class of motor : Premium Efficiency Class IE3 conforming to IS 12615 or IEC:60034-30

हस्ताक्षर एवं दिनांक SIGN & DATE									
				नाम NAME	दिनांक एवं हस्ताक्षर SIGNATURE & DATE				
	TSX	D.K. Mandar	<i>peepal</i> 11/02/16	अनुवादक TRANSLATED BY					
				निर्माणकर्ता WORKED BY	TARUN BANSAL	<i>TB</i> 12/10/16			
	QAX	VIBHUTI SHAH	<i>Vibhuti</i> 22/11/16	जांचकर्ता CHECKED BY	ROHIT BANSAL	<i>R.B.</i> 22/11/16			
	सहमत विभाग AGREED DEPTT.	नाम NAME	दिनांक एवं हस्ताक्षर DATE & SIGNATURE	पर्यवेक्षणकर्ता SUPERVISED BY	SHASHI KANT	<i>skant</i> 22/10/2016			
				स्वीकृति APPROVED	S.K. BAVEJA, AGM (HXE & PED)	<i>S.K. Baveja</i> 24/11/16			G.P. No. 267
	REV. NO.	11	SUPERCEDES	निर्माण PREPARED :	HXE	जारी ISSUED :	TSX	दिनांक DATE :	6/3/88
	Dt.								
	CA:HXE-1603		12/10/16						

COPYRIGHT AND CONFIDENTIAL
 The information on this documents is the property of Bharat Heavy Electrical Limited. It must not be used directly or indirectly in any way detrimental to the interest of the company.

स्वत्वाधिकार एवं गोपनीय
 इस प्रलेख में दी गई सूचना भारत हेवी इलेक्ट्रिकल्स की सम्पत्ति है इसका प्रत्यक्ष एवं अप्रत्यक्ष रूप से किसी भी तरह प्रयोग, जो कि कंपनी के हित में हानिकारक हो न किया जाए।

P-5718

दिनांक एवं हस्ताक्षर
SIGN & DATE



उत्पाद मानक (हीप - हरिद्वार)

HE 57008

पृष्ठ का

PRODUCT STANDARD (HEEP - HARIDWAR)

Page 2 of 11

SUPERSEDES
INVENTORY
NO

सामग्री सूची
संख्या को
अधिकृतित करता

COPYRIGHT AND CONFIDENTIAL
The information on this documents is the property of Bharat Heavy Electrical Limited. It must not be used directly or indirectly in any way detrimental to the interest of the company

स्वत्वाधिकार एवं गोपनीय
इस प्रलेख में दी गई सूचना भारत हेवी इलेक्ट्रिकल्स की सम्पत्ति है इसका प्रयुक्त एवं अप्रयुक्त रूप से किसी भी तरह प्रयोग, जो कि कम्पनी के हित में हानिकारक हो न किया जाए।

हस्ताक्षर एवं दिनांक
SIGN & DATE

सामग्री सूची संख्या
INVENTORY NO.

2.3 GENERAL REQUIREMENT :

2.3.1 The exhausters shall be supplied in pairs for each set , such that when two units (per set) are installed with motor fan axis coinciding in one line (horizontal), one unit shall be a mirror image of the other. (Refer Figure - 2).

2.3.2 Vibration of the equipment shall be limited to the maximum displacement of 50 microns. The measurement procedure shall be broadly as per IS: 12075.

2.3.3 Noise level shall not be more than 85 dB at a distance of 1 meter. Noise level test shall carried out generally as per IS: 12065.

2.3.4 Dynamic balancing of the impeller shall be done generally as per ISO: 1940 of the balance quality grade G6.3.

2.3.5 The impeller shall be zinc sprayed. (Minimum thickness 60 micron).

2.3.6 All the parts of the exhauster and motor shall be of corrosion resisting material or shall suitably and durably protected against corrosion.

2.3.7 Suitable foundation on bolts (M16 x110) along with nut (M16), lock nut (M16) Spring washer 4 nos. (each) shall be supplied by the vendor for mounting of the equipment on foundation.

2.3.8 Dimensional details shall be as per Figure -1

2.3.9 Each fan exhauster shall be performance test at supplier's works as per IS: 4894.

2.3.10 In the event of placement of order, General Arrangement drawing of the exhauster unit shall be got approved before starting manufacturing of Air Exhauster.

3.0 DESIGN, MANUFACTURE & WORKMANSHIP :

3.1 The protective measure of exhauster shall be as per of IS 4894. In assembled condition, live parts shall not be accessible with the standard test finger (see IS: 1401).

3.2 The welding of the equipment shall be carried out by a qualified welder as per ASME Sec-IX.

3.3 The motor shall have delta type stator winding connection.

3.4 Minimum voltage required under starting up conditions to bring exhauster up to rated speed shall be 85% of rated voltage.

3.5 Before starting manufacturing of Air Exhauster , the vendor shall get its detailed drawing approved by BHEL, which shall include detailed dimensions and bill of material.

3.6 Permissible variation in dimensions mentioned in Table-II shall be as follows:

- i) Nominal dimension : From 30 mm – 120 mm : +/- 2 mm
- ii) - do - : From 121 mm – 315 mm : +/- 2 mm
- iii) - do - : From 316 mm - 1000 mm : +/- 3 mm

3.7 To cater for continuous operational requirement at the power station, the air exhauster and motor shall be of proven design.

3.8 All flanged connections (inlet and outlet) shall be supplied with matching counter flanges in bolted condition along with fasteners to permit trouble free assembly of inter connecting pipelines.

4.0 MATERIAL :



The material of construction used should satisfy the operational stresses, i.e. mechanical, thermal and chemical. It should be certified by the supplier that the material quoted by them in the part list has been used and is suitable for intended service requirements.



REV.NO. 11	SUPERSEDES	निर्माणकर्ता WORKED BY	TARUN BANSAL	SD/-	14/10/16
		जांचकर्ता CHECKED BY	ROHIT BANSAL	SD/-	14/10/16

P-5718

14/10/14

दिनांक एवं हस्ताक्षर SIGN & DATE		उत्पाद मानक (हीप - हरिद्वार)		HE 57008	
		PRODUCT STANDARD (HEEP - HARIDWAR)		पृष्ठ	का
				Page	3 of 11
सामग्री सूची संख्या को अधिकृत किया जाएगा	SUPERSEDES INVENTORY NO.	5.0 DATA REQUIRED WITH THE BID / OFFER:			
		Supplier to furnish the following data / documents in duplicate along with the offer :			
		5.1	The general arrangement drawing & catalogue / literature relevant to the product.		
		5.2	Part lists		
		5.3	Data sheets duly filled in formats attached with this specification. Foundation drawing along with embossment details of the foundation bolts etc.		
		5.4	The list of recommended spares required for a period of 5 years.		
		6.0	IDENTIFICATION :		
		6.1	The fan exhauster with motor assembly should have name plate of corrosion resistant material and must include the following information :		
		6.1.1	Name of equipment.		
		6.1.2	Model No.		
		6.1.3	Motor rating.		
		6.1.4	Name of supplier		
		6.1.5	BHEL specification No He 57008.		
		6.1.6	Identification Sl No. 1 or 2, as shown in Figure-2		
		6.1.7	Power factor.		
		6.1.8	Weight of the equipment.		
		6.2	The direction of rotation should be embossed on the equipment at an easily locating position.		
		7.0	INSPECTION AND TESTING:		
		7.1	The final inspection shall be carried out by BHEL'S representative. A notice of minimum 4 weeks shall be given by supplier for witnessing tests / checks for each lot of air-exhauster with motor. Representative shall have free access to the supplier's works for the purpose of inspection and testing of the air exhauster with motor, and vendor shall provide him all necessary help in carrying out the inspection.		
			Approval of tests / inspection and there by issue of test certificates, or waiver of inspection by the purchaser shall not relieve the vendor of his responsibilities and obligations under contract for safe and satisfactory performance of the fans.		
		7.2	Tests listed under clause 7.3 shall be carried out as per procedures laid down in IS : 4894. If facilities for any of the tests mentioned below does not exist with the supplier, then relevant test certificates issued by approved test laboratories / institutes shall be supplied in original. Supplier shall supply all test certificates as listed in clause no 7.3.		
		7.3	Minimum tests / checks to be carried out on air exhauster, are given below.		
सामग्री सूची संख्या	REV.NO.		निर्माणकर्ता WORKED BY	TARUN BANSAL	SD/-
P-5718	11		जांचकर्ता CHECKED BY	ROHIT BANSAL	SD/-
अस्ताक्षर एवं दिनांक SIGN & DATE					

दिनांक एवं हस्ताक्षर SIGN & DATE		उत्पाद मानक (हीप - हरिद्वार)		HE 57008	
		PRODUCT STANDARD (HEEP - HARIDWAR)		पृष्ठ का	Page 4 of 11
SUPERSEDES INVENTORY NO.	<p>7.3.1 AIR EXHAUSTER:</p> <ul style="list-style-type: none"> i. Air delivery test to meet the requirement of clause 2.3.9. ii. Vibration test, to meet the requirement of clause 2.3.2. iii. Noise level test, to meet the requirement of clause 2.3.3. iv. Dimensional Check v. Material check: Material certificate shall be as per approved drg. / material list by BHEL. vi. Fan speed (Acceptance test). vii. Balancing of rotating parts to meet the requirements of clause 2.3.4 viii. 100% soap bubble test shall be carried out for no leakage of Casing & Gasket joints at design pressure. <p>7.3.2 : MOTOR:</p> <ul style="list-style-type: none"> (a) TYPE TESTS: <ul style="list-style-type: none"> i. Temp. rise test. ii. Full load test. (b) ROUTINE TESTS <ul style="list-style-type: none"> i. High voltage test. ii. Insulation resistance test. iii. Earthing continuity test iv. Electrical input test. <p>7.4 TOLERANCE ON RATINGS :</p> <p>The difference between the observed test results and the ratings assigned by the manufacturer shall not exceed the tolerances given below :</p> <ul style="list-style-type: none"> a) Air delivery (-) 10 % b) Electrical input (+) 10% c) Speed (+/-) 10 % d) Deficiency (-) 15%. <p>8.0 DOCUMENTS REQUIRED ALONG WITH SUPPLY OF EXHAUSTER UNIT SET :</p> <ul style="list-style-type: none"> 8.1 Certified copies of test results of tests listed under paragraph 7.2.& 7.3 in 5 copies. 8.2 Dimensional drawings showing erection details in 5 nos. 8.3 Operating and maintenance manual in 5 nos. 8.4 Packing lists. 8.5 Final data sheets on the format enclosed with this specification in 5 nos.. 8.6 Guarantee certificate: The supplier shall guarantee trouble free operation of the equipment for a minimum period of one year after installation and undertake to replace / repair the damaged components free of cost with in the guarantee period. 8.7 A copy each of the above-referred documents, along with one reproducible of item at clause 8.2 shall be dispatched separately to BHEL, Hardwar before dispatch of consignment. 				
<p>स्वत्वाधिकार एवं गोपनीय</p> <p>इस प्रलेख में ली गई सूचना भारत की इलेक्ट्रिकल्स की सम्पत्ति है इसका प्रत्यक्ष एवं अप्रत्यक्ष रूप से किसी भी तरह प्रयोग, जो कि कंपनी के हित में हानिकारक ही न किया जाए ।</p>					
संशोधन सूची संख्या INVENTORY NO.	REV.NO.	निर्माणकर्ता WORKED BY	TARUN BANSAL	SD/-	
7-5718		जांचकर्ता CHECKED BY	ROHIT BANSAL	SD/-	

दिनांक एवं हस्ताक्षर SIGN & DATE		उत्पाद मानक (हीप - हरिद्वार)		HE 57008			
		PRODUCT STANDARD (HEEP - HARIDWAR)		पृष्ठ	का		
सामग्री सूची संख्या को अतिरिक्त करना	SUPERSEDES INVENTORY NO.	9.0 INTER CHANGEABILITY : The motor of the exhauster of a particular size and model and set of blades shall be Changeable such that the performance of the equipment remains within specified limits.		Page	5 of 11		
सामग्री सूची संख्या को अतिरिक्त करना	COPYRIGHT AND CONFIDENTIAL The information on this document is the property of Bharat Heavy Electrical Limited. It must not be used directly or indirectly in any way detrimental to the interest of the company	10.0 QUALITY PLAN : Quality Plan shall be submitted along with the offer for approval. Prior approval of Quality Plan is necessary before manufacturing.					
		11.0 PAINTING : The equipment is to be painted with the paints given below after cleaning the surfaces by shot blasting etc., giving a clean dry and metallic finish.					
स्वत्वाधिकार एवं गोपनीय इस परीक्षण में ही गई सूचना भारत हेवी इलेक्ट्रिकल्स की सम्पत्ति है इसका प्रयोग एवं अपर्याप्त रूप से किसी भी तरह प्रयोग, जो कि कंपनी के हित में हानिकारक हो न किया जाए।		11.1 INTERNAL SURFACES : Inner chamber of the exhauster are to be preserved with steam Washable preservation oil/ paint having viscosity of 38 centistokes at 40° c.					
		11.2 OUTER SURFACES : Outer surfaces of exhauster shall be painted as per following details : I. Inland conditions: Process a) and c) as per details below to be used for inland application with final DFT as 100 microns. II. Sea Condition : Process a),b) and c) as per details below to be used with final DFT as 100 microns. a) Priming : Epoxy resin based 2 pack Zinc Phosphate with DFT 50 microns. b) Intermediate : TiO ₂ pigmented epoxy resin intermediate paint. c) Finish : Epoxy resin based finish paint.					
दिनांक एवं हस्ताक्षर SIGN & DATE	REV.NO.	12.0 DESPATCH :					
		12.1 The exhauster units shall be directly dispatched to the site as described in the Purchase Order.					
सामग्री सूची संख्या	INVENTORY NO.	12.2 All openings to be suitably blanked with blanking plates/counter flanges as specified in Cl. 3.8.					
		12.3 All loose items to be packed separately in a small box and kept inside the main packing box for the exhauster units.					
दिनांक एवं हस्ताक्षर SIGN & DATE	REV.NO.	12.4 Packing should be sea worthy and must be able to protect the equipment in tropical climate.					
		12.5 Following information should be painted on the packing box : a) Name of the equipment. b) BHEL Purchase Order No. c) BHEL Specification No. HE-57008.					
सामग्री सूची संख्या	INVENTORY NO.	13.0 LIST OF CROSS REFERRED STANDARDS AND SPECIFICATIONS :					
		a) ASME - IX	b) ISO - 1940	c) IS - 1401			
दिनांक एवं हस्ताक्षर SIGN & DATE	REV.NO.	d) IS - 4691	e) IS - 4894	f) IS - 12065			
		g) IS - 12075	h) IS- 12615	i) IEC:60034-30			
सामग्री सूची संख्या	INVENTORY NO.	निर्माणकर्ता		WORKED BY	TARUN BANSAL	SD/-	
		जांचकर्ता		CHECKED BY	ROHIT BANSAL	SD/-	

दिनांक एवं हस्ताक्षर SIGN & DATE
 सामग्री सूची संख्या INVENTORY NO. **R-5918**
 SUPERSEDES INVENTORY NO.

स्वत्वाधिकार एवं गोपनीय
 इस प्रलेख में दी गई सूचना भारत हेतु इलेक्ट्रिकल्स की सम्पत्ति है इसका प्रयोग एवं अनुकूलन बिना लिखित अनुमति के बिना न किया जाए।
Copyright and Confidential
 The information on this documents is the property of Bharat Heavy Electrical Limited. It must not be used directly or indirectly in any way detrimental to the interest of the company.

TABLE-1

PARAMETERS	UNIT S	TYPE							
		A	B	C	A1	B1	C1	D	E
SUCTION TEMPERATURE	°C	70	80	84	70	80	84	80	80
HEAD DEVELOPED	mmW C	310	306	410	310	306	410	306	500
FLOW VOLUME	M ³ /se C.	0.3	0.4	0.3	0.3	0.4	0.3	0.7	0.7
DENSITY OF AIR STEAM MIXTURE AT SUCTION TEMPERATURE AND 85% RH	Kg/M ³	0.923	0.846	0.780	0.923	0.846	0.780	0.846	0.846

कर्ताहर एवं दिनांक SIGN & DATE **11/2/16**
 सामग्री सूची संख्या INVENTORY NO. **R-5918**
 REV.NO. **11**

निर्माणकर्ता WORKED BY	TARUN BANSAL	
जांचकर्ता CHECKED BY	ROHIT BANSAL	

दिनांक एवं हस्ताक्षर SIGN & DATE



उत्पाद मानक (हीप - हरिद्वार)

HE 57008

PRODUCT STANDARD (HEEP - HARIDWAR)

पृष्ठ का
Page 7 of 11

SUPERSEDES INVENTORY NO.

सामग्री सूची संख्या को अतिरिक्त करना

COPYRIGHT AND CONFIDENTIAL

The information on this documents is the property of Bharat Heavy Electrical Limited. It must not be used directly or indirectly in any way detrimental to the interest of the company

स्वत्वधिकार एवं गोपनीय

इस प्रलेख में दी गई सूचना भारत हेवी इलेक्ट्रिकल्स की सम्पत्ति है। इसका प्रत्यक्ष एवं अप्रत्यक्ष रूप से किसी भी तरह प्रयोग, जो कि कंपनी के हित में हानिकारक हो न किया जाए।

हस्ताक्षर एवं दिनांक SIGN & DATE

17/5/16

सामग्री सूची संख्या INVENTORY NO.

P-57-18

REV.NO.

11

निर्माणकर्ता
WORKED BY

TARUN BANSAL

SD/-

Tarun Bansal

जांचकर्ता
CHECKED BY

ROHIT BANSAL

SD/-

Rohit Bansal

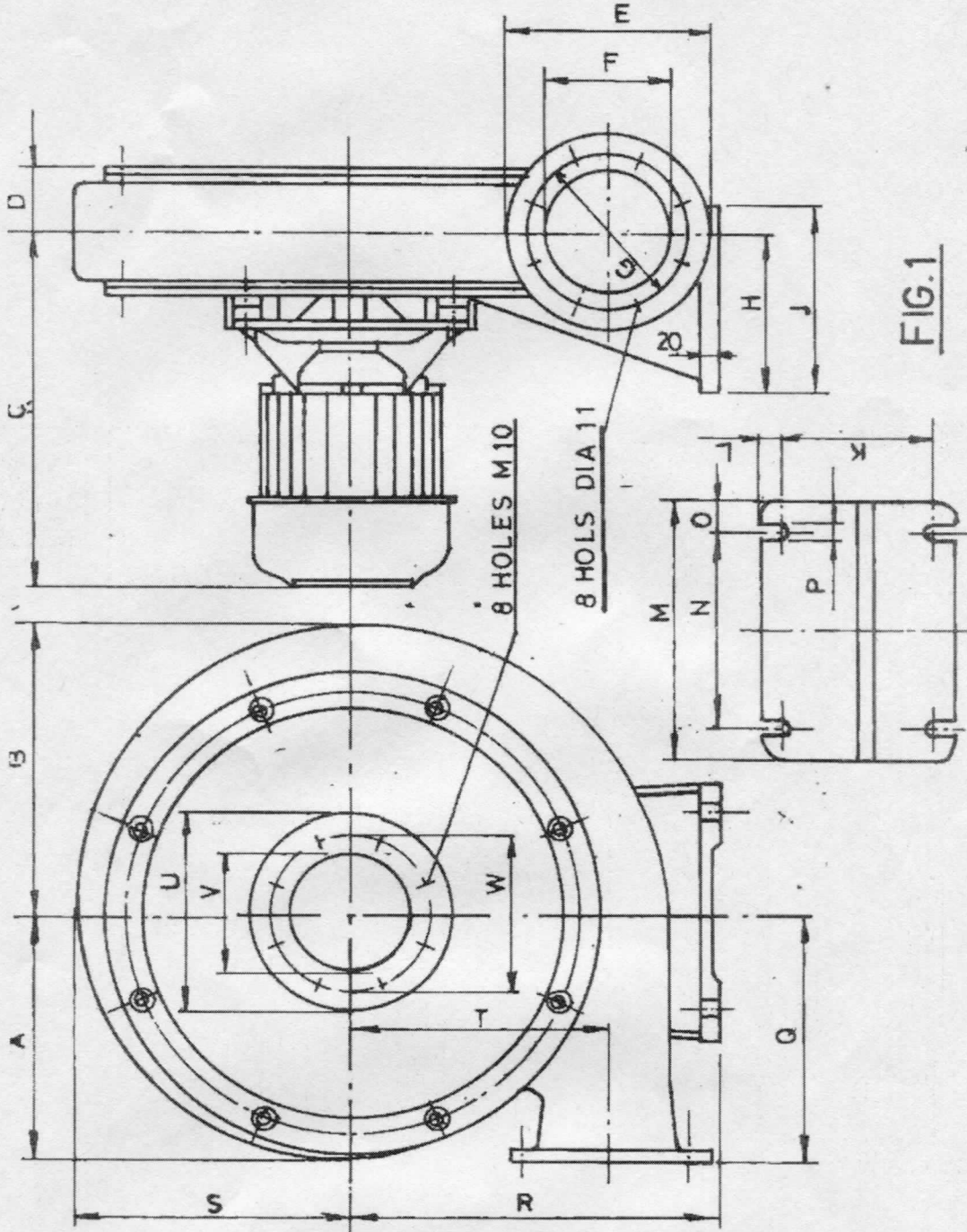

SUPERSEDES INVENTORY NO.
 सामग्री सूची संख्या की अधिकतम संख्या



DIMENSIONAL DETAIL OF FIGURE-1
DIMENSIONAL DETAIL OF FIGURE-1

COPYRIGHT AND CONFIDENTIAL
 The information on this documents is the property of Bharat Heavy Electrical Limited. It must not be used directly or indirectly in any way detrimental to the interest of the company.

SL NO	TYPE DIMENSION	A	B	C	A1	B1	C1	D	E
01	A	≈212	≈263	≈263	≈300	≈300	≈360	≈360	≈360
02	B	≈268	≈318	≈318	≈350	≈350	≈425	≈425	≈425
03	C	≈445	≈450	≈425	≈540	≈540	≈560	≈540	≈540
04	D	72	80	80	115	115	135	135	135
05	E	φ 216	φ234	φ234	φ234	φ234	φ274	φ280	φ280
06	F	φ140	φ160	φ160	φ160	φ160	φ200	φ200	φ200
07	G (PCD)	φ182	φ200	φ200	φ200	φ200	φ240	φ240	φ240
08	H	172	180	180	180	180	210	243	243
09	J	200	200	200	243	243	243	343	343
10	K	164	164	164	207	207	207	307	307
11	L	18	18	18	18	18	18	18	18
12	M	250	280	280	364	364	364	464	464
13	N	190	220	220	304	304	304	404	404
14	O	30	30	30	30	30	30	30	30
15	P	18	18	18	18	18	18	18	18
16	Q	215	270	270	320	320	380	400	400
17	R	330	390	390	440	440	530	530	530
18	S	≈240	≈284	≈284	≈325	≈325	≈390	≈390	≈390
19	T	220	267	267	310	310	370	370	370
20	U	φ216	φ234	φ234	φ234	φ234	φ274	φ280	φ280
21	V	φ140	φ160	φ160	φ160	φ160	φ200	φ200	φ200
22	W (PCD)	φ182	φ200	φ200	φ200	φ200	φ240	φ240	φ240

स्वत्वाधिकार एवं गोपनीय
 इस प्रलेख में दी गई सूचना भारत हेवी इलेक्ट्रिकल्स की सम्पत्ति है इसका प्रयोग एवं आयाजक रूप से किसी भी तरह प्रयोग, जो कि कंपनी के हित में हानिकारक हो न किया जाए।

अंश/दिनांक एवं दिनांक
 SIGN & DATE
 11/12/16

सामग्री सूची संख्या INVENTORY NO. P-5718	REV.NO. 11		निर्माणकर्ता WORKED BY TARUN BANSAL	
			जांचकर्ता CHECKED BY ROHIT BANSAL	

सामग्री सूची संख्या का अधिकारित क्रमांक
 SUPERSEDES INVENTORY NO.



COPYRIGHT AND CONFIDENTIAL
 The information on this documents is the property of Bharat Heavy Electrical Limited. It must not be used directly or indirectly in any way detrimental to the interest of the company

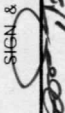

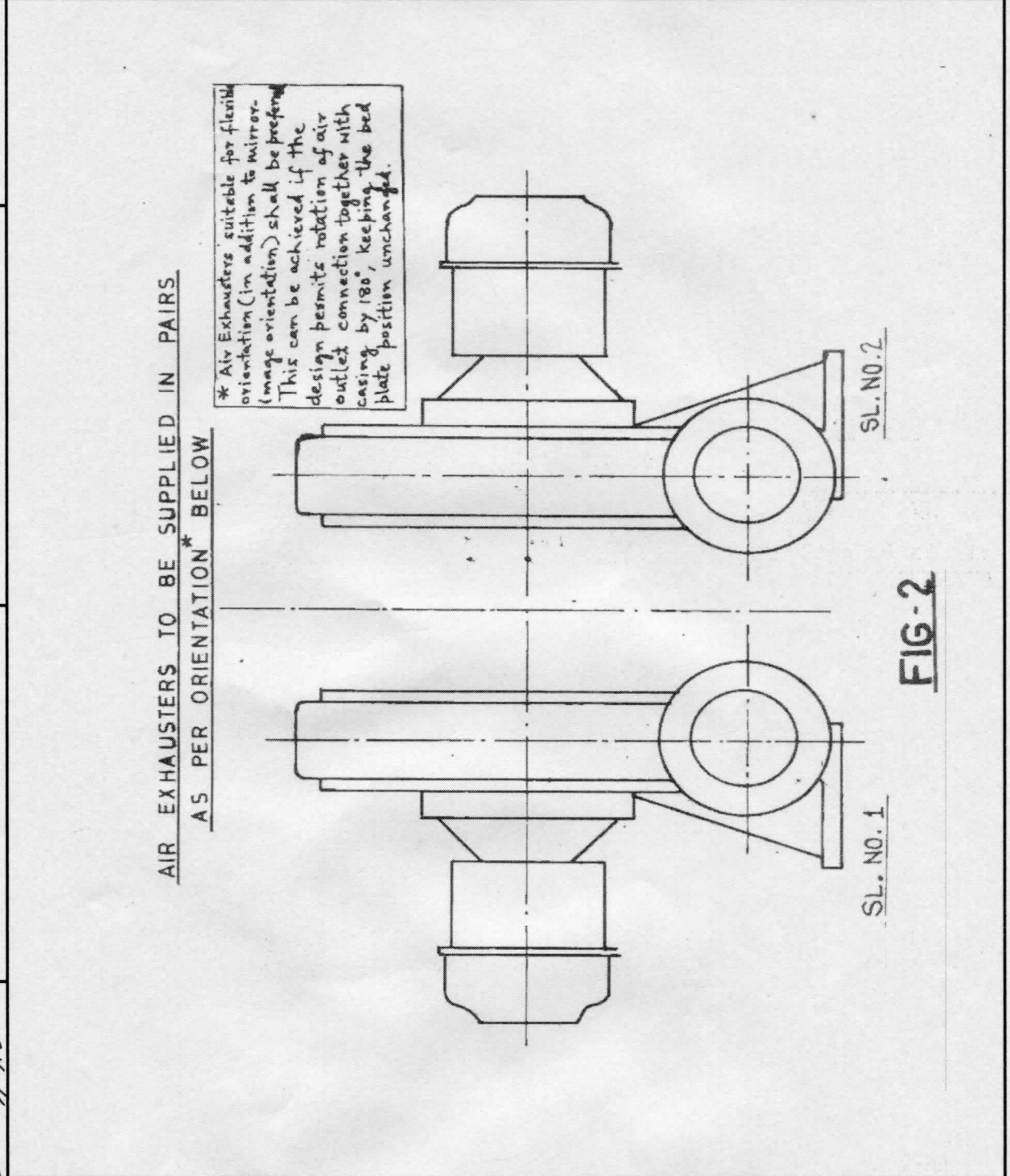

स्वत्वाधिकार एवं गोपनीय
 इस प्रलेख में दी गई सूचना भारत हेवी इलेक्ट्रिकल्स की सम्पत्ति है इसका प्रत्यक्ष एवं अप्रत्यक्ष रूप से किसी भी तरह प्रयोग जो कि कम्पनी के हित में हानिकारक हो न किया जाए।





हस्ताक्षर एवं दिनांक
 SIGN & DATE

 11/2/16

सामग्री सूची संख्या
 INVENTORY NO.
P-5718



REV.NO. 11		निर्माणकर्ता WORKED BY	TARUN BANSAL	SD/-	
		जांचकर्ता CHECKED BY	ROHIT BANSAL	SD/-	

दिनांक एवं हस्ताक्षर SIGN & DATE		उत्पाद मानक (हीप - हरिद्वार)		HE 57008	
		PRODUCT STANDARD (HEEP - HARIDWAR)		पृष्ठ	का
SUPERSEDES INVENTORY NO.	DATA SHEET				
सामग्री सूची संख्या की अधिकतम संख्या	<p>A. FAN</p> <ol style="list-style-type: none"> 1. Name of manufacturer 2. Model No. 3. Position 4. Flow dry air M³ / sec 5. Pressure difference k p a 6. Flow steam mixture m³ / sec 7. Mixture temp 8. Pressure difference k p a (with air steam mixture) 9. Density of mixture kg / m³ 10. Density of medium during test kg / m³ 11. Power absorbed K W 12. Speed RIM 13. Weight of rotating part kg 14. Weight of fan exhaustor kg 15. Moment of inertia kg m² 16. Standard and degree of rotor balancing 17. Static or Total Efficiency <p>B. MOTOR:</p> <ol style="list-style-type: none"> 1. Model No. 2. Rating K W 3. Rated voltage 4. Frequency 50 Hz 5. Speed R P M 6. Degree of protection 7. Rated current amp 				
<p>स्वत्वाधिकार एवं गोपनीय</p> <p>इस प्रलेख में दी गई सूचना भारत हेवी इलेक्ट्रिकल्स की सम्पत्ति है इसका प्रयोग एवं आरक्षण काय से किसी भी तरह प्रयोग, जो कि कंपनी के हित में हानिकारक हो न किया जाए।</p>					
<p>COPYRIGHT AND CONFIDENTIAL</p> <p>The information on this documents is the property of Bharat Heavy Electrical Limited. It must not be used directly or indirectly in any way detrimental to the interest of the company</p>					
सामग्री सूची संख्या	REV.NO.	निर्माणकर्ता	TARUN BANSAL	SD/-	
INVENTORY NO.	11	WORKED BY			
P-57/18		जांचकर्ता	ROHIT BANSAL	SD/-	
दिनांक एवं हस्ताक्षर SIGN & DATE		CHECKED BY			
					

दिनांक एवं हस्ताक्षर SIGN & DATE		उत्पाद मानक (हीप - हरिद्वार)		HE 57008	
		PRODUCT STANDARD (HEEP - HARIDWAR)		पृष्ठ	का
समूची सूची संख्या को अधिकारित करता	SUPERSEDES INVENTORY NO.		Page	11	of 11
COPYRIGHT AND CONFIDENTIAL The information on this documents is the property of Bharat Heavy Electrical Limited. It must not be used directly or indirectly in any way detrimental to the interest of the company.		8. Power factor 9. Starting current Amp 10. Temp. Rise over 50 °C ambient, °C 11. Class of insulation 12. Rated torque - NM 13. Starting torque -NM 14. Weight of rotating part, Kg 15. Weight of motor - Kg 16. Moment of inertia Kg-m ² . 17. Efficiency Class of motor C. ASSEMBLY: 1. Weight, Kg 2. Foundation bolts & nut - Yes 3. Drawing No.			
स्वत्वाधिकार एवं गोपनीय इस प्रलेख में दी गई सूचना भारत हेवी इलेक्ट्रिकल्स की सम्पत्ति है इसका प्रत्यक्ष एवं अप्रत्यक्ष रूप से किसी भी तरह प्रयोग, जो कि आपकी कतिपय में हानिकारक हो न किया जाए।					
करताक्षर एवं दिनांक SIGN & DATE					
समूची सूची संख्या INVENTORY NO.	REV.NO.	निर्माणकर्ता WORKED BY		TARUN BANSAL	SD/- 
P53718	11	जांचकर्ता CHECKED BY		ROHIT BANSAL	SD/- 



ANNEXURE-1: DETAILS OF EQUIPMENT

Bidder's Name and Address :
XXXXXXX

To
BHEL, HEEP, RANIPUR,
Haridwar-249403

Details of manufacture of proven equipments.

S. No.	Item Description
A.	CENTRIFUGAL EXHAUSTER/BLOWER DIRECTLY COUPLED WITH MOTOR
1.00.00	Name, Address & Telephone No. of the manufacturer
1.01.00	Name and location of the Plant where the exhauster is installed
1.02.00	Client Name and its Address, Fax No. & Tel.Nos.
1.03.00	Name and Designation of the responsible person in Client's Organisation
1.03.00	PO No. and Date
1.04.00	Date of Commissioning of System/Package

Signature of authorized signatory...

- | | | | |
|---------|--------|------------------------------------------------------------------------------------------------------------------------------|--------|
| 1.05.00 | (a) | Whether the System/Equipments are in Successful Operation for a minimum period of two (2) years prior to the date of enquiry | Yes/No |
| | (b) | Whether the system/equipments are in successful operation as prior to date of enquiry | Yes/No |
| 1.06.00 | | Brief Technical Particulars of the System/Package/Equipments : | |
| | (i) | Designed by | |
| | (ii) | Manufactured by | |
| | (iii) | Fan Type | |
| | (iv) | Design Standard | |
| | (v) | Whether Directly coupled with motor | Yes/No |
| | (vi) | Working medium being handled by Exhauster | |
| | (vii) | Operating Temperature of working medium | |
| | (viii) | Density of working medium (kg/m ³) | |
| | (ix) | Head developed by exhauster at above density(mmWC) | |
| | (x) | Flow rate of working medium (m ³ /sec) | |
| | (xi) | Diameter of impeller after machining (mm) | |
| | (xii) | HP rating of Exhauster motor | |
| | (xiii) | Make of Motor | |
| | (xiv) | Power absorbed by motor | |
| | (xv) | Profile of blades of impeller (Straight/ Backward curved/ Forward curved) | |
| | (xvi) | Whether Counter Flanges supplied with Exhauster | Yes/No |

QUALITY PLAN											Page 1 of 2		
BHEL	QP NO.	QA/BE/QP/307		REV.	05		DESCRIPTION				LEGENDS		
	SPEC. NO.	HE57008		REV.	AS PER PO		AIR EXHAUSTER WITH MOTOR (GSC AIR EXHAUSTER)				P- PERFORMED BY		1- BHEL REP
	DRG. NO.	APPROVED DRAWING /DATA SHEET		REV.	AS PER PO						W- WITNESSED BY		2- VENDOR
											V- VERIFIED BY		3- SUBVENDOR
SL. NO.	CHARACTERISTICS		CLASS	TYPE OF CHECK	QUANTUM OF CHECK	REFERENCE DOCUMENT	ACCEPTANCE NORMS	FORMAT OF RECORDS		AGENCY			REMARKS
1	2	3	4	5	6	7	8	9	D	10		11	

1. RAW MATERIAL													
1.1	CASING, IMPELLER, BLADES & BASE FRAME/ PLATE	CHEMICAL COMPOSITION MECHANICAL PROPERTIES SIZE	MAJOR	CHEMICAL MECHANICAL MEASUREMENT	1 / HEAT 100%	ORDERING SPEC. / BHEL APPD. DRG. & DATA SHEET	ORDERING SPEC. / BHEL APPD. DRG. & DATA SHEET	MTC	✓ ✓ ✓	P P P	V V V	V V V	
1.2	NUTS & BOLTS	TRADE MARK & PROPERTY CLASS	MAJOR	VISUAL	100%	As per vendor's Procedure	As per vendor's Procedure	IR	✓	P	V	-	
1.3	AC INDUCTION MOTOR	ROUTINE & TYPE TESTS CERTIFICATE INCLUDING DEGREE OF PROTECTION	MAJOR	REVIEW	100%	IS 325/ IS 4722/ BHEL Spec.	IS 325/ IS 4722 & BHEL SPEC.	TC	✓	P	V	V	
2. INPROCESS INSPECTION													
2.1	CASING, MOTOR BRACKET, BASE FRAME & INLET CASING	QUALITY OF WELD	MAJOR	DPT	100%	ORDERING SPEC. / BHEL APPD. DRG. & DATA SHEET	ORDERING SPEC. / BHEL APPD. DRG. & DATA SHEET	IR	✓	P	V		NOTE:1
2.2	IMPELLER	DIMENSIONS DIMENSIONS AFTER MACHINING DYNAMIC BALANCING	MAJOR	MEASUREMENT	100%	BHEL APPD. DRG	BHEL APPD. DRG	IR IR	- -	P P	- -		
2.3	ASSEMBLY OF FAN	INTERNAL CLEARANCES BETWEEN IMPELLER & CASING	MAJOR	MEASUREMENT	100%	BHEL APPD. DRG	BHEL APPD. DRG	IR	✓	P	V		
3.0 FINAL INSPECTION													
3.1	COUNTER FLANGE	PHYSICAL VERIFICATION	MAJOR	VISUAL	100%	BHEL APPD. DRG	BHEL APPD. DRG	COC	✓	P	W	-	

		LEGEND: ! RECORDS IDENTIFIED WITH 'TICK' SHALL BE ESSENTIALLY INCLUDED BY CONTRACTOR IN QA DOCUMENTATION. M: MANUFACTURER / SUBCONTRACTOR B: BHEL / NOM. INSPECTION AGENCY N: CUSTOMER INDICATE 'P' PERFORM 'W' WITNESS AND 'V' VERIFICATION ALL 'W' INDICATED IN COLUMN 'N' SHALL BE 'CHP' OF CUSTOMER	FOR CUSTOMER USE	
MANUFACTURER/ SUBCONTRACTOR				APPROVED BY

QUALITY PLAN											Page 2 of 2			
BHEL	QP NO.	QA/BE/QP/307		REV.	05		DESCRIPTION				LEGENDS			
	SPEC. NO.	HE57008		REV.	AS PER PO		AIR EXHAUSTER WITH MOTOR (GSC AIR EXHAUSTER)				P- PERFORMED BY		1- BHEL REP	
	DRG. NO.	APPROVED DRAWING /DATA SHEET		REV.	AS PER PO						W- WITNESSED BY		2- VENDOR	
								V- VERIFIED BY		3- SUBVENDOR				
SL. NO.	CHARACTERISTICS		CLASS	TYPE OF CHECK	QUANTUM OF CHECK	REFERENCE DOCUMENT	ACCEPTANCE NORMS	FORMAT OF RECORDS		AGENCY			REMARKS	
1	2	3	4	5	6	7	8	9	D	10			11	

3.2	COMPLETE ASSEMBLY	OVERALL DIMENSIONS	MAJOR	MEASUREMENT	100%	BHEL SPEC/APPD DRG	BHEL SPEC/APPD DRG	Dim. Report	✓	P	W	V	
3.3		THICKNESS OF ZINC COATING OF IMPELLER	MAJOR	MEASUREMENT	100%	BHEL SPEC/APPD DRG	BHEL SPEC/ APPD DRG	IR	✓	P	V	-	
3.4		LEAKAGE TEST OF CASING & GASKET JOINTS AT DESIGN PRESURRE	MAJOR	LEAK TEST (SOAP SOLUTION)	100%	BHEL SPEC/APPD DRG	NO LEAKAGE (NO BUBBLE)	TC	✓	P	W	V	
3.5		PERFORMACE TEST (INCLUDING AIR DELIVERY, PRESSURE & POWER CONSUMPTION)	MAJOR	PERFORMANCE	100%	IS 4894/ BHEL APPD. DRG/DATASHEET/ SPEC	IS 4894/ BHEL APPD. DRG	TC	✓	P	W	V	
3.6		FAN SPEED AT 85 % OF RATED VOLTAGE	MAJOR	ELECTRICAL	100%	BHEL SPEC/APPD DRG	RATED SPEED	TC	✓	P	W	V	
3.7		FAN SPEED, SMOOTH RUNNING & DIRECTION OF ROTATION	MAJOR	VISUAL	100%	BHEL SPEC/APPD DRG	BHEL SPEC/ BHEL APPD DRG.	IR	✓	P	W	-	
3.8		NOISE LEVEL	MAJOR	MEASUREMENT	100%	BHEL SPEC/APPD DRG	BHEL SPEC/ BHEL APPD DRG.	TC	✓	P	W	V	
3.9		VIBRATION	MAJOR	MEASUREMENT	100%	BHEL SPEC/APPD DRG	BHEL SPEC/ BHEL APPD DRG.	TC	✓	P	W	V	
3.10		APPEARANCE INCLUDING PAINT THICKNESS (DFT)	MAJOR	VISUAL & MEASUREMENT	100%	BHEL SPEC/APPD DRG	BHEL SPEC	TC	✓	P	V	V	
3.11		COMPLIANCE OF TECHNICAL REQUIREMENT	MAJOR	--	100%	BHEL SPEC/APPD DRG	BHEL SPEC/ BHEL APPD DRG	COC	✓	P	V	-	
3.12		COMPLETION OF DOCUMENTS	MAJOR	PHYSICAL	100%	BHEL SPEC/ BHEL APPD DRG/ QP/ PO	BHEL SPEC/ BHEL APPD DRG/ QP/ PO	DOCUMENTS		P	-		
4.0 PACKING													
4.1		SOUNDNESS OF PACKING AGAINST TRANSIT DAMAGE	MAJOR	PHYSICAL	100%	BHEL SPEC/ VENDOR'S STD	BHEL SPEC/ VENDOR'S STD	IR		P	-		

NOTE: 1 Welding to be done by qualified welder as per ASME IX WPS and PQR to be checked by inspecting Agency.

MANUFACTURER/ SUBCONTRACTOR	LEGEND:	FOR CUSTOMER USE	APPROVED BY
	! RECORDS IDENTIFIED WITH 'TICK' SHALL BE ESSENTIALLY INCLUDED BY CONTRACTOR IN QA DOCUMENTATION.		
	M: MANUFACTURER / SUBCONTRACTOR B: BHEL / NOM. INSPECTION AGENCY N: CUSTOMER INDICATE 'P' PERFORM 'W' WITNESS AND 'V' VERIFICATION ALL 'W' INDICATED IN COLUMN 'N' SHALL BE 'CHP' OF CUSTOMER		

PRE QUALIFICATION REQUIREMENTS (PQR) for Air Exhauster with Motor (Type-E)
(Mat Code: W90716121050) ; Indent No: 20240202

Pre-Qualification Requirements for the procurement of Air Exhauster with Motor (Type-E) are as below:

1. Bidder/ Vendor should have designed, manufactured and supplied equipment of the type and minimum equipment rating as stipulated below:

Type of equipment	Equipment Rating
Centrifugal Exhauster/ Blower directly coupled with motor	Flow 0.4 m ³ /sec (minimum) with head 250 mmWC (minimum) for dry air and motor rating 3 HP (minimum)

2. In support of the above Clause 1, bidder/vendor to submit following documents:
 - i. Un-priced copy of Purchase Order for exhauster coupled with motor stipulated in the Table of clause 1.
 - ii. Duly filled "DETAILS OF EQUIPMENT" for which purchase order copy as per clause 2.i is furnished (Format as per Annexure-1).
 - iii. Any suitable dispatch document.

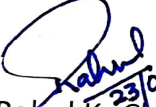
(Rahul Kr Chandra)
Dy. Mgr/HXE

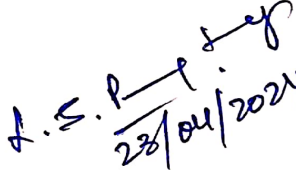
(Lokesh Singh Pangtey)
Manager/ HXE

Buyers Specific Additional Terms & Conditions in addition to GTC

Item Name: GSC Air Exhauster with Motor

Projects: 2X800 MW Mahan Supercritical TPP, Bandhaura project

A. SCOPE OF ENQUIRY

E-bids on GeM are invited from bidders for the supply of **GSC Air Exhauster with Motor** for MAHAN, 2 x 800MW Project, as per requirement mentioned below:

Sl. No.	Project	Material Code & Item Description	Total Quantity	LOT Quantity	Date for Supply Completion
1	MAHAN SUPERCRITICAL 2 x 800MW	Material Code W90716121050 Air Exhauster with Motor	02 Nos.	(Lot-1)	05.07.2025
2		SPEC: HE 57008 REV: 11, Type-E, Motor type-IE3, Confirming to IS-12615 or IEC:60034-30)	02 Nos	(Lot-2)	05.11.2025
Project Name & Address		Mahan Energen Limited. 2x800 MW (Phase-II) Thermal Power Project Village: Bandhaura, Karsulal, Tehsil: Waidhan District. Singrauli, Pin-486886, Madhya Pradesh			

B. Buyers Specific Additional Terms & Conditions in addition to GTC

Sl. No.	Terms	Description	Your confirmation
1.	Confirmation to compliance of GeM GTC	General terms and conditions on GeM 4.0 (Version 1.14). Please submit signed & stamped copy of the same.	
2.	Prices	Prices should be quoted on F.O.R. Destination basis including of freight, packing & forwarding charges, GST etc. Item to be supplied directly to MAHAN Project site. Bidder to Confirm that the prices will remain firm during the entire validity and execution of the Project.	
		The evaluation currency for this tender shall be INR.	
		Please note that transit insurance of material shall be in BHEL scope only. Please quote your offer accordingly.	
3.	Evaluation criteria	Evaluation will be done on the basis of total landed cost to BHEL, with cost involved for delivery up to BHEL MAHAN project site (considering ITC). Bidders to insure applicability of ITC on Gem portal.	
4.	Pre-Qualification Requirement	Please note that procurement shall be done only from the vendors who full-fill the PQR requirement and accepted by our engineering. Bidders are required to fill the required data along with supporting document for BHEL review and approval. Offers of only those vendors will be considered who qualify the PQR before opening of price-bids.	
5.	Delivery Period	Please quote your lot wise delivery completion period in line with delivery schedule mentioned in bid. In case it is not possible to meet the lot date, you may quote your best possible delivery completion period in number of weeks/months from the date of Manufacturing Clearance. 	
6.	Manufacturing clearance from BHEL/End customer	Lot/ Unit wise manufacturing shall be start only after lot/ unit wise manufacturing clearance from BHEL/ END Customer. PLEASE CONFIRM.	

7.	Payment Terms	Payments shall be made to the Seller within 90 days after issue of consignee receipt-cum-acceptance certificate (CRAC) and on-line submission of bills. For Micro/ small & Medium (covered under MSME Act), payment will be made within 45 days & 60 days respectively from PRC after issue of consignee receipt-cum-acceptance certificate (CRAC) and on-line submission of bills. Bidders to provide MSME / UDYAM certificate for payment schedule finalization.	
8.	Liquidated Damages	LD shall be as per clause no. 15 (iii) of General terms and conditions on GeM 4.0 (Version 1.4).	
		The date of GR/LR shall be treated as the date of delivery for penalty/ all purposes	
9.	MDCC clause	Material shall be dispatched only after issue of material dispatch clearance certificate (MDCC) by BHEL. All test certificates and relevant documents, applicable TCs/reports are to be sent to BHEL before dispatch of material for issue of MDCC/Dispatch clearance by BHEL, which will be issued after review of test certificates etc. MDCC will be issued within 07 days of receipt of these documents once found complete in all respects. In case of any delay on account of BHEL in issuing MDCC, delivery shall be extended by no. of days in excess of 7 days taken by BHEL in issuing MDCC and delays shall be dealt on merit basis. Material is to dispatched within 07 days of receipt of MDCC from BHEL without waiting for PO amendment.	
10.	Reverse Auction	Opening of Price bid & RA shall be conducted for only those bidders who qualifies PQR whose techno-commercial bid is acceptable to BHEL. RA will be done amongst lowest price bid (after H1 elimination) technically qualified bidders as per GeM RA guidelines. (Just for information)	
11.	Technical Requirements	Material specification as per Spec HE57008 rev 11, Type-E only. Motor type-IE3, Confirming to IS-12615 or IEC:60034-30)	
		Anti-Vibrating pads (for all Exhausters) to be provided for limiting the vibration in limit as per clause 2.3.2 of specification HE 57008 rev-11.	
		Kindly confirm that quoted offer by you have been complied all technical requirements as given in tender documents and submit all documents to BHEL as per tender specifications and drawings without any deviations.	
12.	Quality Requirements	1. Bidders to submit endorse copy of BHEL SQP QA/BE/QP/307, Rev-05. 2. BHEL can modify / changes in above QP during QP approval. 3. Bidders to confirm that inspection shall be by done by BHEL Nominated inspection agency (M/s TUV/ QUEST) as per BHEL approved QP. 4. Please note that BHEL will pay directly to BHEL's nominated TPI.	
13.	Engineering Document/ Document approval	Drawings/Data sheets/Documents/ Quality Plan etc. as called for in the specifications shall be submitted for approval to BHEL for BHEL approval within 30 days of purchase order. Any delay in delivery on account of late submission of drawings shall be to vendors account. BHEL will arrange the approval of the drawings/data sheets/ documents within 30 days of their receipt provided those are complete in all respect. Delays in approval shall be dealt on merit basis.	
14.	Guarantee	Guarantee/ Warranty Period: 12 months from the date of commissioning or 18 months from dispatch, whichever is earlier. Guarantee certificate is to be provided along with shipping / dispatch documents. Please confirm. Note:- Offers with guarantee period lesser than above mentioned guarantee period may result in rejection of the offer.	

		Supplier shall be responsible for free replacement of the defective part/ material, defect due to any other causes pertain to manufacturing / material) on our site without any extra cost to BHEL	
		In case of damage in transit due to inadequacy in packing / loading on truck/trailer, it will be vendor's responsibility to replace defective / damaged material on F.O.R. site basis, without any additional charges to BHEL.	
15.	HSN Code & Other Instructions	8 DIGIT GST HSN CODE OF ITEM MAY PLEASE BE FREEZED WITH VENDOR BEFORE PO PLACEMENT. PLEASE PROVIDE.....	
		1. INVOICE, GR/LR, MDCC, PKG LIST ALONG WITH E-WAY BILL IS REQUIRED FOR BILLING. 2. DOCUMENTS (GR/LR, PACKING LIST, TEST CERTIFICATES) ARE REQUIRED IN ORIGINAL.	
16.	Risk Purchase	In case of abnormal delays (beyond the maximum late delivery period as per LD clause) in supplies / defective supplies or non-fulfillment of any other terms and conditions given in Purchase Order, BHEL may cancel the Purchase Order in full or part thereof, and may also make the purchase of such material from elsewhere / alternative source at the risk and cost of the supplier. BHEL will take all reasonable steps to get the material from alternate source at optimum cost. If bidder does not agree to the above Risk Purchase Clause, BHEL reserves the right to reject the offer. In case for compelling reasons BHEL accepts the offer without acceptance of this clause by the bidder and in the eventuality of Risk Purchase, appropriate action will be taken as per BHEL extant rules. This will be without prejudice to any other right of BHEL under the contract or under General Law. Kindly confirm.	
17.	Action against Bidders	In order to protect the commercial interests of BHEL, BHEL shall take action against supplies / contractors by way of suspension of business dealings, who either fail to perform or are in default without any reasonable cause, cause loss of business/ money/ reputation, indulge in malpractices, cheating, bribery, fraud or any other misconduct or formation of cartels so as to influence the bidding process or influence the price etc. Suspension of Business Dealings could be in the form of "Hold" or "Banning" a supplier/ contractor or a bidder and shall be as per "Guidelines for Suspension of Business Dealings with Suppliers/ Contractors" available at BHEL's website " https://www.bhel.com/guidelines-suspension-business-dealings-supplierscontractors "	
18.	Arbitration:	In case of any dispute arising out of as in connection with this contract, the same shall be referred to arbitration under Arbitration & Conciliation Act 1996 of a sole arbitrator who shall be appointed by mutual consent of the parties. The seat & venue of arbitration shall be Haridwar. The proceedings shall be conducted in English. The Governing law of contract shall be the substantive law of India.	
19.	Breach of contract, Remedies and Termination	Please note that in case of breach of contract, at least 10% of the contract value shall be recovered from financial remedies (i.e. available bills of the contractor, retention amount, etc. with BHEL) or legal remedies be pursued. The balance scope shall be got done independently without Risk & Cost of the failed supplier/ contractor. Further, levy of liquidated damages, debarment, termination, de-scoping, short-closure, etc., shall be applied as per provisions of the contract. Please confirm.	
20.	Right to reserve	BHEL reserves the right to cancel tender or reject any or all the quotations without assigning any reasons thereof. BHEL also reserves the right to Increase or decrease the tendered quantities. Kindly confirm.	
21.	Bidder Contact details	Contact details of your representative: Mobile no. & Email id (minimum 2 person) 1. 2.	