

**R&M OF STEAM TURBINE OF UKAI THERMAL POWER STATION,
U# 3 (1 x 200 MW) & U#5 (1 x 210 MW)**

BOQ-CUM-PRICE SCHEDULE FOR LT PVC CONTROL CABLE

Sr. No.	Item code	Item description	Unit	Order Quantity	Standard drum length	UNIT PRICE in Rs	TOTAL PRICE in Rs	REMARKS
1.0		MAIN SUPPLY						
		1.1 KV CU. CONDUCTOR, PVC INSULATED, INNER & OUTER SHEATH FRLSH (PVC-ST1) AND ARMoured CONTROL CABLE.						
(i)	507-37021-A	5C-2.5 ARMoured	MTR	4,000	1000 mtr			
(ii)	507-37031-A	7C-2.5 ARMoured	MTR	16,000	1000 mtr			
(iii)	507-37061-A	9C-2.5 ARMoured	MTR	2,000	1000 mtr			
(iv)	507-37003-A	12C-2.5 ARMoured	MTR	16,000	1000 mtr			

NOTES:-

1	The standard drum length shall be 1000 metres as indicated above. Tolerance on individual drum shall be $\pm 5\%$.
2	Overall tolerance on total dispatched quantity of each size shall be (-) 2% and (+) 0% except where the total ordered quantity is one single drum length of 1000m, in which case it shall be -5% to 0%. Cables consumed for testing and inspection shall be to bidder's account.
3	For each individual cable size, one short length of not less than 200m may be accepted only in final drum length to complete the supply (except where the total ordered quantity is one single drum length of 1000m). The overall tolerance limits stipulated above shall continue to apply (in case short lengths are accepted).
4	In case of the quantities cleared by BHEL for manufacturing are manufactured and offered for inspection by successful bidder in more than one batch, BHEL reserves the right to witness type testing on all batches without any price implications.
5	Unit price of cables quoted by bidder shall be inclusive of all tests (i.e routine, acceptance, type test) except UV Radiation test & Hydrolytic Stability test. No separate charges shall be payable for any test except as mentioned at S.no-6.
6	The charges of UV Radiation & Hydraulic stability test, shall be reimbursed extra at actual against Original money receipt of Govt. Lab. (CPRI / ERDA).

**R&M OF STEAM TURBINE OF UKAI THERMAL POWER STATION,
U# 3 (1 x 200 MW) & U#5 (1 x 210 MW)
ANNEXURE-1**

BOQ-CUM-PRICE SCHEDULE FOR LT PVC CONTROL CABLE- MANDATORY SPARES

Sr. No.	Item code	Item description	Unit	Order Quantity	Standard drum length	UNIT PRICE in Rs	TOTAL PRICE in Rs	REMARKS
2.0	507-30000-B	MANDATORY SPARES						
		1.1 KV CU. CONDUCTOR, PVC INSULATED, INNER & OUTER SHEATH FRLSH (PVC-ST1) AND ARMOURED CONTROL CABLE.						
(i)		5C-2.5 ARMOURED	MTR	500	500 mtr			
(ii)		7C-2.5 ARMOURED	MTR	1,000	1000 mtr			
(iii)		12C-2.5 ARMOURED	MTR	1,000	1000 mtr			

NOTES:-

1	The standard drum length shall be 500/1000 metres as indicated above. Tolerance on individual drum shall be $\pm 5\%$.
2	Overall tolerance on total dispatched quantity of each size shall be (-) 2% and (+) 0% except where the total ordered quantity is one single drum length of 1000m, in which case it shall be -5% to 0%. Cables consumed for testing and inspection shall be to bidder's account.
3	For each individual cable size, one short length of not less than 200m may be accepted only in final drum length to complete the supply (except where the total ordered quantity is one single drum length of 1000m). The overall tolerance limits stipulated above shall continue to apply (in case short lengths are accepted).
4	In case of the quantities cleared by BHEL for manufacturing are manufactured and offered for inspection by successful bidder in more than one batch, BHEL reserves the right to witness type testing on all batches without any price implications.
5	Unit price of cables quoted by bidder shall be inclusive of all tests (i.e routine, acceptance, type test) except UV Radiation test & Hydrolytic Stability test. No separate charges shall be payable for any test except as mentioned at S.no-6.
6	The charges of UV Radiation & Hydraulic stability test, shall be reimbursed extra at actual against Original money receipt of Govt. Lab. (CPRI / ERDA).
7	Quantity of mandatory spares indicated above shall be released alongwith ordered quantity (indicated in Main supply) after approval of technical and quality documentation. Mandatory spares shall be clearly identified.



1780509/2023/PS-PEM-EL

	PRE-QUALIFICATION REQUIRMENTS OF LT PVC CONTROL CABLE FOR R&M OF STEAM TURBINE OF UKAI THERMAL POWER STATION, U# 3 (1 x 200 MW) & U#5 (1 x 210 MW)	PE-PQ-499-507-E003
		REVISION NO.0 DATE 07/11/2023
		SHEET NO. 1 OF 1

ITEMS : LT PVC CONTROL CABLE	
SCOPE : Supply : YES; Erection & Commissioning : NO;	
1.0	Vendor should be a manufacturer of LT control cables.
2.0	Availability of test reports of tests on LT PVC/HRPVC FRLS control cables to establish in- house capability to carry out all routine, type & acceptance tests as per relevant IS/international standards (except UV radiation & hydrolytic stability test which can be conducted at Govt. lab/ Govt. approved independent lab).
3.0	Capacity of manufacturing 10 km of LT control cable per month.
4.0	Manufactured and supplied at least one (1) km of FRLS cables.
5.0	Manufactured and supplied LT control cables upto 12 cores.
6.0	Manufactured and supplied at least 30 km of LT control cables of min. 2.5 sq. mm. in one or more orders and at least 10 km in one single order.
7.0	Minimum two (2) nos. purchase orders for LT PVC/ HRPVC control cable shall be submitted which should not be more than five (5) years old from the date of techno- commercial bid opening for establishing continuity in business.

NOTES:

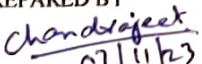
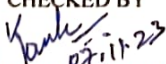
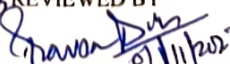
1. Consideration of bidder's offer is subject to customer approval.
2. Bidder to submit all supporting documents in English. If documents submitted by bidder are in language other than English, a self-attested English translated document should also be submitted.
3. Notwithstanding anything stated above, BHEL reserves the right to assess the capabilities and capacity of the bidder/collaborators to perform the contract, should the circumstances warrant such assessment in the overall interest of BHEL.
4. After satisfactory fulfillment of all the above criteria requirement, offer shall be considered for further evaluation as per NIT and all the other terms of the tender.

PREPARED BY  NAME: CHANDRAJEET RATHAUR DESIGNATION: MANAGER	CHECKED BY  NAME: KANHAIYA KUMAR / HEMA KUSHWAHA DESIGNATION: SR.MGR/ DGM	REVIEWED BY  NAME: PRAVEEN DUTTA DESIGNATION: AGM	APPROVED BY  NAME: DEBASISA RATH DESIGNATION: DH-ELECT (AGM)
--	--	--	---

	TECHNICAL SPECIFICATION & DATA SHEET FOR LT PVC CONTROL CABLE	Specification No.: PE-TS-499-507-E003
		Rev. No. 00
		Date : 07.11.2023

**RENOVATION & MODERNISATION OF STEAM TURBINES
OF UKAI TPS U# 3 (1 x 200 MW) & U#5 (1 x 210 MW)**

**TECHNICAL SPECIFICATION
FOR
LT PVC CONTROL CABLE**

SPECIFICATION No. **PE-TS-499-507-E003**



**BHARAT HEAVY ELECTRICALS LIMITED
POWER SECTOR
PROJECT ENGINEERING MANAGEMENT DIVISION
NOIDA, INDIA**

	TECHNICAL SPECIFICATION & DATA SHEET FOR LT PVC CONTROL CABLE	Specification No.: PE-TS-499-507-E003
		Rev. No. 00
		Date : 07.11.2023
INDEX		
SL NO.	DESCRIPTION	SHEET NO.
1	SCOPE	3
2	SPECIFICATION & DATA SHEET FOR LT PVC CONTROL CABLE	4 TO 7
3	IMPORTANT INSTRUCTIONS	8
4	BILL OF QUANTITY (BOQ) (INCLUDING SPARES)	6
5	PAINTING REQUIREMENT	10
6	PACKING REQUIREMENT	10
7	DOCUMENTATION REQUIREMENT	12
8	QUALITY PLAN	13 TO 32

	TECHNICAL SPECIFICATION & DATA SHEET FOR LT PVC CONTROL CABLE	Specification No.: PE-TS-499-507-E003
		Rev. No. 00
		Date : 07.11.2023
SCOPE		
SCOPE OF THIS PACKAGE COVERS THE FOLLOWING:		
	SUPPLY (INCLUDING DESIGN, ENGINEERING, MANUFACTURING, CALIBRATION, INSPECTION, TESTING, PAINTING, PACKING, TRANSPORTATION & DELIVERY TO SITE)	YES
	ERECTION & COMMISSIONING	NO
	SUPERVISION OF ERECTION & COMMISSIONING	NO
	COMMISSIONING SPARE	NO
	MANDATORY SPARE	YES
	O & M SPARE	NO

		TECHNICAL SPECIFICATION & DATA SHEET FOR LT PVC CONTROL CABLE	Specification No.: PE-TS-499-507-E003 Rev. No. 00 Date : 07.11.2023
A. SPECIFICATION & DATA SHEET FOR LT PVC CONTROL CABLE			
S.No.	Particulars	Description	
1	Type of Cable	Flame Retardant-Low Smoke (FR-LSH) LT CABLE	
1.1	Voltage Grade	1.1 KV	
2	STANDARDS APPLICABLE		
2.1	Standard applicable in general (Latest amendment to be referred if any)	IS:1554 (Part-1)	
2.2	Current rating of cables conforms to	As per IS:3961 (P-2)	
2.3	Short circuit rating conforms to	IEC 60949	
3	INSTALLATION CONDITIONS AT SITE		
3.1	Ambient air temperature (deg. C)	50 ▼	
3.2	Ground temperature (deg. C)	30	
3.3	Depth of laying of cables buried in ground (cm)	90	
3.4	Thermal resistivity of soil (K.m/W)	1.5	
5	CONDUCTOR		
5.1	Applicable standard	IS: 8130	
5.2	Material type	Electrolytic annealed tinned copper (ATC) ▼	
5.3	Grade	Annealed high conductivity	
5.4	Class	Class 2 (Stranded) ▼	
5.5	Shape	Circular	
5.6	Compaction	Non-Compacted ▼	
5.7	Cable Size (sq.mm)	Refer BOQ as per NIT ▼	
6	PVC INSULATION		
6.1	Material	Extruded PVC Type-A	
6.2	Standard Applicable	IS: 5831	
6.3	Continuous withstand temperature	70°C	
6.4	Short-circuit withstand temperature	160°C	
6.5	Method of application	By extrusion; sleeve extrusion not permitted.	
6.6	Nominal thickness of insulation (mm)	As per Table-2 of IS: 1554 (Part-1)	
7	CORE IDENTIFICATION		
7.1	Control Cables up to 5 core	Colour coding as per IS 1554 (Part-1)	
7.2	Control Cables above 5 cores	By numbering as per IS 1554 (Part-1). Insulation to have black colour.	
8	INNERSHEATH		
8.1	Standard Applicable	IS: 5831	
8.2	Material	Extruded PVC Type ST-1	
8.3	Colour	Black	
8.4	Whether FR-LSH	YES ▼	
8.6	Fillers acceptable	Acceptable	
8.7	Material of fillers (if permitted)	Same as inner sheath (Material of filler to be compatible with that of inner sheath)	
8.8	Method of application	Extrusion	
(1)	Multi-core cables:		
(i)	With fillers	Pressure/ Vacuum ▼	
(ii)	Without fillers	Pressure extruded	
8.9	Thickness of inner sheath	As per IS 1554 (Part-1)	

9	ARMOUR	
9.1	Standard Applicable	Galvanised Steel Round Wire/ Galvanised Steel Formed Wire Conforming to : (i) Type 'a' / 'b' as per Table-5 of IS 1554-I and (ii) IS 3975; as per project requirements.
9.2	Material (Multi core)	Galvanised Steel Round Wire/ Galvanised Steel Formed Wire ▼
9.3	Minimum Coverage	90%
9.4	Tolerance on formed wire dimension	±10 %
9.5	Gap between armour wire	Shall not exceed one armour wire space (No cross over / Over riding)
9.6	Breaking load of Joint	95% of normal armour
9.7	Paint on joint	Zinc rich paint shall be applied on armour joint surface of G.S.wire / formed wire
9.8	Maximum resistivity of GS Round wire (Ohm-cm)	14.5×10^{-6}
10	OUTERSHEATH	
10.1	Standard Applicable	IS: 5831
10.2	Material	Extruded PVC Type ST1 as per IS: 5831.
10.3	Colour	Black ▼
10.4	Whether FR-LSH	YES
10.5	Method of application	Extruded
10.6	Thickness of outer sheath	As per Table-7 of IS: 1554 (Part-1)
10.7	Marking/ Embossing on Outersheath	(i) Owner's name (i.e GSECL) (ii) Manufacturer's name and trade mark, (iii) Year of manufacture, (iv) Type of cable and voltage class, (v) Nominal cross section area of conductor and no. of cores, (vi) 'BHEL-PEM'. (vii) Progressive Sequential length marking, @ 1M (by printing) BHEL-PEM & CUSTOMER NAME (i.e GSECL), MANUFACTURER'S NAME AND/OR TRADE MARK, VOLTAGE GRADE, YEAR OF MANUFACTURE, TYPE OF INSULATION, NO. OF CORE AND SIZE OF CABLE, FRLSH, IS NUMBER, - AT EVERY 5M (BY EMBOSSING)
11	FR-LSH CHARACTERISTICS	
11.1	Oxygen index	Minimum 29 as per ASTM D 2863 ▼
11.2	Temperature index	Minimum 250°C as per ASTM D 2863 ▼
11.3	Acid gas generation	Maximum 20% by weight as per IEC-60754-1 ▼
11.4	Smoke density rating	Maximum 60% as per ASTM D 2843 ▼
12	TYPE TEST CONDUCTION REQUIRED	YES ▼
13	FLAMMABILITY	
13.1	Flammability test for single cable	As per IS 7098 Part 1 (IS 10810 Part 53) ▼
13.2	Flammability test for bunched cables	IEC-332-1
13.3	Flammability test as per IEEE: 60383	YES ▼
13.4	As per Swedish Chimney test SEN-SS-424-1475-F3	YES ▼
14	Anti-rodent and Termite repulsion Test	YES ▼
15 (a)	Anti-Fungal Test (self certification by supplier for Anti-fungal properties)	YES ▼
15 (b)	Insulation & Inner Sheath Material resistant to oil acid and alkali (self certification by supplier)	YES

16	Special Tests	
16.1	Hydrolytic Stability as per ASTM D 3137 :81 (Duration:- 14 days)	YES
16.2	UV Radiation Test as per BS EN ISO 4892-2 (Duration:- 14 days)	YES
16.3	UV Radiation Test as per ASTM G 154 (Duration:- 14 days)	NO
17	DIAMETERS	
17.1	Tolerance on overall diameter ((±) mm)	(±) 2 mm. over the declared value
18	Minimum bending radius (x O.D.)	
18.1	Multi core cables	12 x O.D.
19	Safe pulling force (kg)	
19.1	Copper conductor cable	50 N/ sq. mm.
21	CABLE DRUM DETAILS	
21.1	Type of Drum	Wooden (as per IS 10418)
21.2	Outermost Layer	To be covered with water-proof polyethylene
21.3	Construction Details	All wooden parts from seasoned wood and ferrous parts shall be treated with suitable rust preventive finish or coating. Wooden drum shall be treated by immersing in copper nitrate solution. Both the end of cables shall be properly sealed with heat shrinkable seal secured by 'U' nails so as to eliminate ingress of water during transportation, storage & erection.
21.4	Standard drum length	1000 Metres
21.5	Tolerance on drum length	(±) 5%
21.6	Details of marking on Drum	Refer Markiing details under 'Instructions'.
B. DATA TO BE FURNISHED BY SUCCESSFUL BIDDER AFTER AWARD OF CONTRACT		
0	NAME & ADDRESS OF MANUFACTURER	
4	TECHNICAL PARAMETER (SIZE WISE INFORMATION TO BE FURNISHED)	
4.1	Base current ratings (*) based on Clause No. 3.0	
	(a) In air (Amp)	
	(b) In ground (Amp)	
	(c) ducts (Amp)	
4.2	Properties	
	(a) D.C. resistance of conductor at 20 deg. C (ohm/km)	
	(b) A.C. resistance of conductor at 90 deg. C (ohm/km)	
	(c) Calculated star reactance of cable at normal frequency (ohm/km)	
	(d) Electrostatic capacitance of cable at normal frequency (mF/km)	
	(e) Charging current (A/km)	
	(f) Loss tangent (for reference only)	
5	CONDUCTOR	
5.8	No & dia of wires in each core before stranding (no x mm)	
6	PVC INSULATION	
6.7	Nominal thickness of insulation (mm)	
6.8	Dielectric strength (kv/mm)	
6.9	Volume resistivity at 27° C (ohm-cm)	
6.10	Volume resistivity at 70° C (ohm-cm)	
6.11	Insulation resistance constant at 27° C (M ohm km)	
6.12	Insulation resistance constant at 70° C (M ohm km)	
6.13	Min. Tensile strength (N/mm ²)	
6.14	Min. Elongation at break (%)	
6.15	Negative tolerance on thickness (mm)	
6.16	Fictitious dia over insulation (mm)	

8	INNER SHEATH	
8.10	Minimum thickness of inner sheath	
9	ARMOUR	
9.9	Size/ dimensions	
9.10	Minimum no. of wires/ formed wires	
10	OUTERSHEATH	
10.8	Nominal thickness of outer sheath (mm)	
10.9	Minimum thickness of outer sheath (Unarmored & Armoured cable)	
17	DIAMETERS	
17.2	Nominal Diameter of insulated conductor (mm)	
17.3	Nominal Cable diameter under armour (mm)	
17.4	Nominal Cable diameter over armour (mm)	
17.5	Nominal Overall diameter of cable (mm)	
20	WEIGHTS	
20.1	Weight of cable (kg /km)	
20.2	Weight of conductor (MT/km)	
20.3	Weight of PVC insulation (MT/km)	
20.4	Weight of PVC (Inner Sheath & Fillers) (kg /km)	
20.5	Weight of GS Round Wire / GS formed Wire (kg /km)	
20.6	Weight of PVC (Outer Sheath) (kg /km)	
21	CABLE DRUM DETAILS	
21.7	Dimension of drum (F X B X T) (Approx) (mm)	
21.8	Shipping weight (Approx) (kg)	

Note: As part of document submissions, after award of contract; vendor to furnish consolidated datasheet (A+B) by re-arranging the sl. nos. in logical flow sequence.

	TECHNICAL SPECIFICATION & DATA SHEET FOR LT PVC CONTROL CABLE	Specification No.: PE-TS-499-507-E003
		Rev. No. 00
		Date : 07.11.2023

IMPORTANT INSTRUCTIONS

1. Manufacture, Inspection and Testing at Manufacturer's works, proper packing and delivery to site of LT PVC CONTROL CABLE conforming to this specification.
2. The bidder to quote for items as per price schedule attached with NIT.
3. Documents shall be submitted after placement of order for BHEL & customer's approval as per the schedule specified below:
4. Vendor shall submit the dates for drawing/document submission/BHEL comments/ resubmission after approval of documents.
5. In BOM each of the item to be uniquely identified with item code no. or item Sl. No. Supplier to ensure that all the items which will find separate mention in the packing list are covered in detailed BOM. Supplier to give following undertaking in BOM: " The BOM provided here completes the scope (in content and intent) of material supply under PO no. ---- dtd ----- Any additional material which may become necessary for the intended application of supplied item/package will be supplied free of cost in most reasonable time."
6. Vendor shall submit the dates for drawing/document submission/BHEL comments/ resubmission after approval of documents.

MARKING

Details of marking on Drum:

- a) Manufacturer's name or trade make.
- b) Type of cable & voltage grade.
- c) Year of manufacture.
- d) Type of insulation.
- e) No. of core and sizes of cables.
- f) Cable code - FRLS.
- g) Single length of cable on drum.
- h) Direction of rotation, by arrow.
- i) Approx gross mass.
- k) IS Number

A tag containing same information shall be attached to the leading end of the cable.

TESTING & INSPECTION

1. Bidder shall confirm compliance with the BHEL's Standard Quality Plan (PE-QP-999-507-E003); as attached with the specification, without any deviations. At contract stage, the successful bidder shall submit the Quality Plan for BHEL/ ultimate customer's approval. In case bidder has reference, Quality Plan agreed with ultimate customer, same can be submitted for specific project after award of contract for BHEL/ ultimate customer's approval. There shall be no commercial implication to BHEL on account of Quality plan approval.
2. The bidder shall carry out the type tests (if applicable) as listed in this specification on the equipment to be supplied under this contract. All types and sizes of cables being supplied shall be subjected to type tests (if applicable), routine tests and acceptance tests as specified in specification.
In case the bidder has conducted such specified type test(s) within last ____ years from ____ (zero date/ techno-commercial bid opening date), he may submit during detailed engineering the type test reports to the owner for waiver of conductance of such type test(s). These reports should be for the tests conducted on the equipment similar to those proposed to be supplied under this contract and test(s) should have been either conducted at an independent laboratory or should have been witnessed by a client. The owner reserves the right to waive conducting of any or all the specified type test(s) under this contract. In case this type test report is not acceptable, the bidder has to conduct type test as specified in specification free of cost.
3. The charges of Special tests (i.e. UV Radiation test & Hydrolytic Stability test) if applicable, shall be reimbursed extra at actual against original money receipt of Govt. Lab. (CPRI/ ERDA etc).

1780509/2023/PS-PEM-EL

	TECHNICAL SPECIFICATION & DATA SHEET FOR LT PVC CONTROL CABLE	Specification No.: PE-TS-499-507-E003
		Rev. No. 00
		Date : 07.11.2023
BILL OF QUANTITY		
The bidder to quote for items as per price schedule attached with NIT.		

	TECHNICAL SPECIFICATION & DATA SHEET FOR LT PVC CONTROL CABLE	Specification No.: PE-TS-499-507-E003
		Rev. No. 00
		Date : 07.11.2023

PAINTING

Entire surface to be painted. All ferrous parts used shall be treated with suitable rust preventive finish or coating to avoid rusting during transit or storage. Wooden cable drums shall be treated with copper naphthenates or zinc naphthenates for preserving the wood. Drum number shall be indicated on each drum.

PACKING

1. Normal Packing for Domestic Project
2. Seaworthy Packing for Export Project

Note: The outer most cable layer shall be covered with water proof cover polythene followed by complete drum covering with wooden plank of suitable thickness across flanges.

STEEL DRUM DRAWING (TYPICAL)

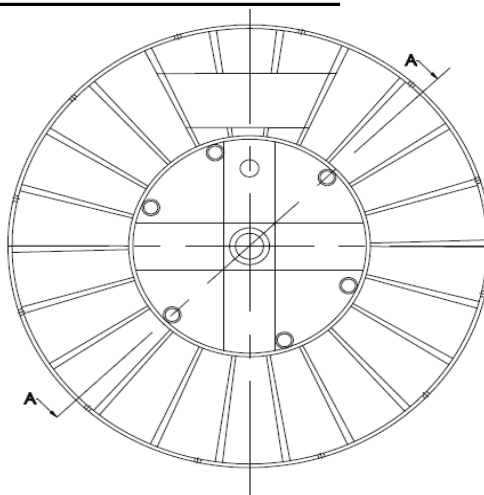
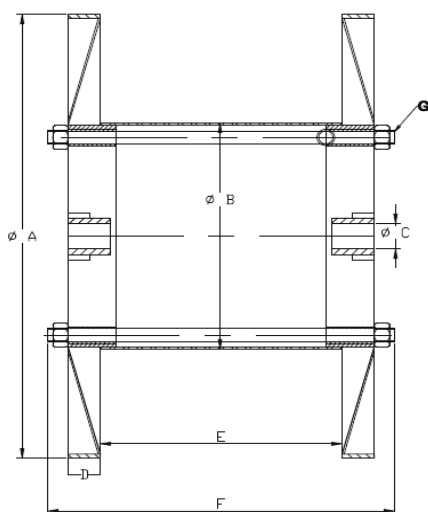

APPROXIMATE DRUM DIMENSIONS IN MM
ALL DIMENSIONS AND VALUES ARE
TYPICAL AND ARE DEPENDENT ON
CABLE WEIGHT.

A	FLANGE	2200
B	BARREL	1200
C	CENTRAL HOLE	100
D	FLANGE	50
E	TRAVERSE	1400
F	GROSS WIDTH	1600
G	STUD SIZE	16 MM.

- Drg. not to scale.
- ALL DIMENSIONS ARE IN MM.

WOODEN PLANKS ACROSS FLANGES FOR STEEL/WOODEN DRUMS (TYPICAL)



	TECHNICAL SPECIFICATION & DATA SHEET FOR LT PVC CONTROL CABLE				Specification No.: PE-TS-499-507-E003
					Rev. No. 00
					Date : 07.11.2023
DOCUMENTATION REQUIREMENT					
DRAWINGS & DOCUMENTS TO BE SUBMITTED AFTER AWARD OF CONTRACT:					
BHEL Drawing No.	Drawing Title	Vendor submission (Days)*	BHEL Comment (Days)	Vendor submission (Days)#	BHEL & Customer comment/ approval (Days)
Primary Documents					
PE-V0-499-507-E131	Datasheet and Cross Section Drawings for LT PVC Control Cables	7	3	2	18
PE-V0-499-507-E216	QAP for LT PVC Control Cables	7	3	2	18
Secondary Documents					
PE-V0-499-507-E133	Type Test Report for LT PVC Control Cables	7	3	2	18
NOTES:					
a) * 1st submission within indicated days from date of purchase order.					
b) # Submission (within indicated days) after incorporating all BHEL comments.					
c) Primary documents shall be considered for Delay analysis					
DRAWINGS & DOCUMENTS TO BE SUBMITTED AS FINAL/AS-BUILT DOCUMENT					
Sl. No.	DOCUMENT TITLE				
1	APPROVED TECHNICAL DATASHEET & GA DRAWING.				
2	APPROVED QUALITY PLAN.				
3	ALL TEST CERTIFICATES				

	MANUFACTURER/ BIDDER/ SUPPLIER NAME & ADDRESS	STANDARD QUALITY PLAN			SPEC. NO.: PE-TS-499-507-E003	DATE:
		CUSTOMER :			QP NO.: PE-QP-999-507-E003, R-1	DATE:
		PROJECT:			PO NO.:	DATE:
		ITEM: 1.LT PVC CONTROL CABLE 2.LT HR PVC CONTRL CABLE 3. LT PVC POWER CABLE 4. LT HRPVC POWER CABLE	SYSTEM:		SECTION: II	SHEET 1 OF 17

SI. No.	COMPONENTS & OPERATIONS	CHARACTERISTICS	CLASS	TYPE OF CHECK	QUANTUM OF CHECK		REFERENCE DOCUMENT	ACCEPTANCE NORMS	FORMAT OF RECORD		AGENCY			REMARKS
					M	C/N			9	D	M	C	N	
1	2	3	4	5	6		7	8	9	*	**			

RAW MATERIAL

Copper Rods	GENERAL:												
	1. Physical properties	MA	Physical Tests	Sample/Batch	Sample /Batch	IS 613	IS 613	Test Certificate	√	P/V	V	-	
	2. Elec. Properties	MA	Electrical Tests	Sample/Batch	Sample /Batch	-do-	-do-	-do-	√	P/V	V	-	
	SPECIFIC CHECKS:												
	a) Make	MA	Verify	100%	100%	Manufacturer approved source	Manufacturer approved source	COC	√	P	V	-	
	b) Grade	MA	-do-	-do-	-do-	IS 613	IS 613	Test Certificate	√	P	V	-	

BHEL				
ENGINEERING		QUALITY		
Prepared by:	Sign & Date <i>Devendra Singh</i> 28-02-2022	Name DEVENDRA SINGH	Checked by:	Sign & Date <i>Kunal Gandhi</i> 28/2/2022
Reviewed by:	Sign & Date <i>Manish Shukla</i> 28/2/2022	Name MANISH SHUKLA	Reviewed by:	Sign & Date <i>R.K. Jaiswal</i> 28/2/2022

BIDDER/ SUPPLIER	
Sign & Date	
Seal	

FOR CUSTOMER REVIEW & APPROVAL			
Doc No:			
Reviewed by:	Sign & Date	Name	Seal
Approved by:			

	MANUFACTURER/ BIDDER/ SUPPLIER NAME & ADDRESS	STANDARD QUALITY PLAN			SPEC. NO.: PE-TS-499-507-E003	DATE:
		CUSTOMER :			QP NO.: PE-QP-999-507-E003, R-1	DATE:
		PROJECT:			PO NO.:	DATE:
		ITEM: LT PVC CONTROL CABLE 2.LT HR PVC CONTRL CABLE 3. LT PVC POWER CABLE 4. LT HRPVC POWER CABLE	SYSTEM:		SECTION: II	SHEET 2 OF 17

Sl. No.	COMPONENTS & OPERATIONS	CHARACTERISTICS	CLASS	TYPE OF CHECK	QUANTUM OF CHECK		REFERENCE DOCUMENT	ACCEPTANCE NORMS	FORMAT OF RECORD		AGENCY			REMARKS
					M	C/N				*	**	M	C	

		c) Resistivity	MA	Electrical Tests	Manufacturer std.	Manufacturer std.	IS 613	IS 613	Test Certificate	√	P	V	-	
	PVC Compound (for insulation)	GENERAL :												
		1. Physical properties	MA	Physical Tests	Sample/Batch	Sample /Batch	IS 5831	IS 5831	Test Certificate	√	P/V	V	-	
		2. Elec.Properties	MA	Electrical Tests	Sample/Batch	Sample /Batch	-do-	-do-	-do-	√	P/V	V	-	
		SPECIFIC CHECKS:												

BHEL					
ENGINEERING			QUALITY		
Prepared by:	Sign & Date	Name	Checked by:	Sign & Date	Name
	<i>Devendra Singh</i>	DEVENDRA SINGH		<i>Kunal Gandhi</i>	KUNAL GANDHI
Reviewed by:	<i>Manish Shukla</i>	MANISH SHUKLA	Reviewed by:	<i>R.K. Jaiswal</i>	R.K. JAISWAL

BIDDER/ SUPPLIER	
Sign & Date	Seal

FOR CUSTOMER REVIEW & APPROVAL			
Doc No:	Sign & Date	Name	Seal
Reviewed by:			
Approved by:			

	MANUFACTURER/ BIDDER/ SUPPLIER NAME & ADDRESS	STANDARD QUALITY PLAN				SPEC. NO.: PE-TS-499-507-E003	DATE:
	CUSTOMER :					QP NO.: PE-QP-999-507-E003, R-1	DATE:
	PROJECT:					PO NO.:	DATE:
	ITEM: LLT PVC CONTROL CABLE 2.LT HR PVC CONTRL CABLE 3. LT PVC POWER CABLE 4. LT HRPVC POWER CABLE	SYSTEM:					SECTION: II

Sl. No.	COMPONENTS & OPERATIONS	CHARACTERISTICS	CLASS	TYPE OF CHECK	QUANTUM OF CHECK		REFERENCE DOCUMENT	ACCEPTANCE NORMS	FORMAT OF RECORD		AGENCY			REMARKS
					M	C/N			9	D	M	C	N	

		a) Make	MA	Verify	100%	100%	Manufacturer approved source	Manufacturer approved source	COC	√	P	V	-	
		b) Type/ Grade	MA	-do-	-do-	-do-	Approved datasheet	Approved datasheet	-do-	√	P	V	-	
		c) Shelf life/ Storage condition	MA	-do-	-do-	-do-	Compound Manufacturer std.	Compound Manufacturer std.	-do-	√	P	V	-	
	Fillers (as applicable)	1. Make	MA	Verify	100%	100%	Manufacturer approved source	Manufacturer approved source	COC	√	P	V	-	Fillers material chosen shall be compatible with the temperature rating of the cable and shall have no deleterious effect on any other component of cable)
		2. Flame retardant & moisture resistant. (as applicable)	CR	Chemical/ Environ.	-do-	-	Appd. Data Sheet	Appd. Data Sheet	-do-	√	P/V	-	-	

BHEL					
ENGINEERING			QUALITY		
Prepared by:	Sign & Date	Name	Checked by:	Sign & Date	Name
	<i>Devendra Singh</i>	DEVENDRA SINGH	<i>Kunal Gandhi</i>		KUNAL GANDHI
Reviewed by:	<i>Manish Shukla</i>	MANISH SHUKLA	<i>R.K. Jaiswal</i>		R.K. JAISWAL

BIDDER/ SUPPLIER	
Sign & Date	Seal

FOR CUSTOMER REVIEW & APPROVAL			
Doc No:	Sign & Date	Name	Seal
Reviewed by:			
Approved by:			

28/02/2020

21/2/2020

	MANUFACTURER/ BIDDER/ SUPPLIER NAME & ADDRESS	STANDARD QUALITY PLAN				SPEC. NO.: PE-TS-499-507-E003		DATE:	
		CUSTOMER :				QP NO.: PE-QP-999-507-E003, R-1		DATE:	
		PROJECT:				PO NO.:		DATE:	
		ITEM: LLT PVC CONTROL CABLE		SYSTEM:		SECTION: II		SHEET 4 OF 17	
2.LT HR PVC CONTRL CABLE		3. LT PVC POWER CABLE		4. LT HRPVC POWER CABLE					

Sl. No.	COMPONENTS & OPERATIONS	CHARACTERISTICS	CLASS	TYPE OF CHECK	QUANTUM OF CHECK		REFERENCE DOCUMENT	ACCEPTANCE NORMS	FORMAT OF RECORD		AGENCY			REMARKS
					M	C/N				*	**	M	C	

	Galvanised steel wire/strip for Armour (if applicable)	GENERAL :												
		1. Make	MA	Verify	Manufacturer std.	Manufacturer std.	Manufacturer approved source	Manufacturer approved source	Inspection report/ Test Certificate	√	P	V	-	
		2. Dimension	MA	Measurement	-do-	-	Approved datasheet	Approved datasheet	-do-	√	P/V	-	-	
		3. Phy.and Elec. Properties	MA	Physical & Electrical Tests	Sample*	-	-do-	-do-	-do-	√	P/V	-	-	* Sample from each armour size/Batch/Lot
		4.Galvanization Quality	MA	Galv.Tests	-do-	-	IS 3975	IS 3975	-do-	√	P/V	-	-	

BHEL					
ENGINEERING			QUALITY		
Prepared by:	Sign & Date	Name	Checked by:	Sign & Date	Name
	<i>Devendra Singh</i>	DEVENDRA SINGH		<i>Kunal Gandhi</i>	KUNAL GANDHI
Reviewed by:	Sign & Date	Name	Reviewed by:	Sign & Date	Name
	<i>Manish</i>	MANISH SHUKLA		<i>R.K. Jaishwal</i>	R.K. JAISWAL

BIDDER/ SUPPLIER	
Sign & Date	
Seal	

FOR CUSTOMER REVIEW & APPROVAL			
Doc No:			
Reviewed by:	Sign & Date	Name	Seal
Approved by:			

	MANUFACTURER/ BIDDER/ SUPPLIER NAME & ADDRESS	STANDARD QUALITY PLAN		SPEC. NO. : PE-TS-499-507-E003	DATE:
		CUSTOMER :		QP NO.: PE-QP-999-507-E003, R-1	DATE:
		PROJECT:		PO NO.:	DATE:
		ITEM 1.LT PVC CONTROL CABLE 2.LT HR PVC CONTRL CABLE 3. LT PVC POWER CABLE 4. LT HRPVC POWER CABLE	SYSTEM:	SECTION: II	SHEET 5 OF 17

Sl. No.	COMPONENTS & OPERATIONS	CHARACTERISTICS	CLASS	TYPE OF CHECK	QUANTUM OF CHECK		REFERENCE DOCUMENT	ACCEPTANCE NORMS	FORMAT OF RECORD		AGENCY	REMARKS
					M	C/N			*	**		
1	2	3	4	5	6	7	8	9	D	M	C	N

PVC compound for Sheath	GENERAL :											
	1. Physical properties	MA	Physical Tests	Sample/Batch	Sample /Batch	IS 5831	IS 5831	Inspection report/ Test Certificate	√	P/V	V	-
	2. Elec.Properties	MA	Electrical Tests	Sample/Batch	Sample /Batch	-do-	-do-	-do-	√	P/V	V	-
	3. FRLS Properties (as applicable)	CR	Chemical/ Environ.	Sample/Batch	Sample /Batch	Approved datasheet	Approved datasheet	-do-	√	P/V	V	-
	SPECIFIC CHECKS :											

BHEL					
ENGINEERING			QUALITY		
Prepared by:	Sign & Date	Name	Checked by:	Sign & Date	Name
	<i>Devendra Singh</i>	DEVENDRA SINGH	<i>Kunal Gandhi</i>	<i>28/02/2020</i>	KUNAL GANDHI
Reviewed by:	<i>Manish Shukla</i>	MANISH SHUKLA	<i>R.K. Jaishwal</i>	<i>28/02/2020</i>	R.K. JAISWAL

BIDDER/ SUPPLIER	
Sign & Date	Seal

FOR CUSTOMER REVIEW & APPROVAL			
Doc No:	Sign & Date	Name	Seal
Reviewed by:			
Approved by:			

	MANUFACTURER/ BIDDER/ SUPPLIER NAME & ADDRESS	STANDARD QUALITY PLAN			SPEC. NO. : PE-TS-499-507-E003	DATE:
		CUSTOMER :			QP NO.: PE-QP-999-507-E003, R-1	DATE:
		PROJECT:			PO NO.:	DATE:
		ITEM: LLT PVC CONTROL CABLE 2.LT HR PVC CONTRL CABLE 3. LT PVC POWER CABLE 4. LT HRPVC POWER CABLE	SYSTEM:	SECTION: II	SHEET 6 OF 17	

Sl. No.	COMPONENTS & OPERATIONS	CHARACTERISTICS	CLASS	TYPE OF CHECK	QUANTUM OF CHECK		REFERENCE DOCUMENT	ACCEPTANCE NORMS	FORMAT OF RECORD		AGENCY			REMARKS
					M	C/N			9	D	M	C	N	

		a) Make	MA	Verify	100%	100%	Manufacturer approved source	Manufacturer approved source	COC	√	P	V	-	
		b) Type/ Grade	MA	-do-	-do-	-do-	Approved datasheet	Approved datasheet	-do-	√	P	V	-	
		c) Shelf life/ Storage condition	MA	-do-	-do-	-do-	Compound Manufacturer std.	Compound Manufacturer std.	-do-	√	P	V	-	
	Wooden drums	1. Phy. & Constructional checks	MA	Visual	Mfr's Plant Std.	Mfr's Plant Std.	IS 10418	IS 10418	Inspection report/ Test Certificate	√	P	V	-	
		2. Anti-termite treatment	MA	Chem.	-do-	-do-	Mfr's Plant Std.	Mfr's Plant Std.	COC	√	P	V	-	

BHEL					
ENGINEERING			QUALITY		
Sign & Date	Name	Checked by:	Sign & Date	Name	
<i>Devendra Singh</i> 28/02/2020	DEVENDRA SINGH	<i>Kunal Gandhi</i> 28/2/2020		KUNAL GANDHI	
<i>Manish Shukla</i> 28/02/2020	MANISH SHUKLA	<i>R.K. Jaiswal</i> 28/2/2020		R.K. JAISWAL	

BIDDER/ SUPPLIER	
Sign & Date	Seal

FOR CUSTOMER REVIEW & APPROVAL			
Doc No:	Sign & Date	Name	Seal
Reviewed by:			
Approved by:			

	MANUFACTURER/ BIDDER/ SUPPLIER NAME & ADDRESS	STANDARD QUALITY PLAN				SPEC. NO.: PE-TS-499-507-E003		DATE:	
		CUSTOMER :				QP NO.: PE-QP-999-507-E003, R-1		DATE:	
		PROJECT:				PO NO.:		DATE:	
		ITEM: LLT PVC CONTROL CABLE		SYSTEM:		SECTION: II		SHEET 7 OF 17	
2.LT HR PVC CONTRL CABLE		3. LT PVC POWER CABLE		4. LT HRPVC POWER CABLE					

Sl. No.	COMPONENTS & OPERATIONS	CHARACTERISTICS	CLASS	TYPE OF CHECK	QUANTUM OF CHECK		REFERENCE DOCUMENT	ACCEPTANCE NORMS	FORMAT OF RECORD		AGENCY			REMARKS
					M	C/N				*	**	M	C	
1	2	3	4	5	6		7	8	9	D				

	Steel drums (If applicable)	1. Dimension	MA	Meas.	Mfr's Plant Std.	Mfr's Plant Std.	Approved drawing of steel drum	Approved drawing of steel drum	Inspection report	√	P	V	-	
		2. Surface finish	MA	Visual	-do-	-do-	Surface shall be smooth	Surface shall be smooth	Inspection report	√	P	V	-	
	IN PROCESS													
	Wire Drawing & Annealing	1. Size	MA	Dimensional	Mfr's Plant Std.	Mfr's Plant Std.	Approved Data Sheet	Approved Data Sheet	Inspection report	√	P	V	-	
		2. Surface finish	MA	Visual	-do-	-do-	Surface shall be smooth	Surface shall be smooth	-do-	√	P	V	-	

BHEL				
ENGINEERING		QUALITY		
Sign & Date	Name	Checked by:	Sign & Date	Name
<i>Devendra Singh</i>	DEVENDRA SINGH	<i>Kunal Gandhi</i>	<i>28/2/2020</i>	KUNAL GANDHI
<i>Manish Shukla</i>	MANISH SHUKLA	<i>R.K. Jaishwal</i>	<i>28/2/2020</i>	R.K. JAISWAL

28/02/2020 *28/2/2020*

BIDDER/ SUPPLIER	
Sign & Date	Seal

FOR CUSTOMER REVIEW & APPROVAL			
Doc No:	Sign & Date	Name	Seal
Reviewed by:			
Approved by:			

	MANUFACTURER/ BIDDER/ SUPPLIER NAME & ADDRESS	STANDARD QUALITY PLAN				SPEC. NO.: PE-TS-499-507-E003	DATE:
	CUSTOMER :					QP NO.: PE-QP-999-507-E003, R-1	DATE:
	PROJECT:					PO NO.:	DATE:
	ITEM: LLT PVC CONTROL CABLE 2.LT HR PVC CONTRL CABLE 3. LT PVC POWER CABLE 4. LT HRPVC POWER CABLE	SYSTEM:	SECTION: II		SHEET 8 OF 17		

Sl. No.	COMPONENTS & OPERATIONS	CHARACTERISTICS	CLASS	TYPE OF CHECK	QUANTUM OF CHECK		REFERENCE DOCUMENT	ACCEPTANCE NORMS	FORMAT OF RECORD		AGENCY			REMARKS
					M	C/N				*	**	M	C	

		3. % of Elongation	MA	Mechanical	-do-	-do-	IS 1554 Pt-1./ IS 8130 & Approved Data Sheet	IS 1554 Pt-1./ IS 8130 & Approved Data Sheet	-do-	√	P	V	-	
	Tinning (Conductor)	1. Size	MA	Dimensional	Plant Mfg. Std.	Plant Mfg. Std.	Mfrs Std	Mfrs Std	-do-	√	P	V	-	(Applicable only for tin-coated copper conductor)
		2. Chemical test for tinning	CR	Chemical	-do-	-do-	IS 10810 Pt-4	IS:8130	-do-	√	P	V	-	
	Stranding of wires	1. No.of wires	MA	Counting	Mfr's Plant Std.	Mfr's Plant Std.	Approved Data Sheet	Approved Data Sheet	-do-	√	P	V	-	
		2. Resistance	CR	Electrical	-do-	-	-do-	-do-	-do-	√	P	-	-	

BHEL					
ENGINEERING			QUALITY		
Prepared by:	Sign & Date	Name	Checked by:	Sign & Date	Name
	<i>Devendra Singh</i>	DEVENDRA SINGH		<i>Kunal Gandhi</i>	KUNAL GANDHI
Reviewed by:	<i>Manish Shukla</i>	MANISH SHUKLA	Reviewed by:	<i>R.K. Jaishwal</i>	R.K. JAISWAL
	28/02/2020			24/2/2020	

BIDDER/ SUPPLIER	
Sign & Date	Seal

FOR CUSTOMER REVIEW & APPROVAL			
Doc No:	Sign & Date	Name	Seal
Reviewed by:			
Approved by:			

	MANUFACTURER/ BIDDER/ SUPPLIER NAME & ADDRESS	STANDARD QUALITY PLAN				SPEC. NO.: PE-TS-499-507-E003		DATE:	
		CUSTOMER :				QP NO.: PE-QP-999-507-E003, R-1		DATE:	
		PROJECT:				PO NO.:		DATE:	
		ITEM: 1.LT PVC CONTROL CABLE 2.LT HR PVC CONTRL CABLE 3. LT PVC POWER CABLE 4. LT HRPVC POWER CABLE		SYSTEM:		SECTION: II		SHEET 9 OF 17	

Sl. No.	COMPONENTS & OPERATIONS	CHARACTERISTICS	CLASS	TYPE OF CHECK	QUANTUM OF CHECK		REFERENCE DOCUMENT	ACCEPTANCE NORMS	FORMAT OF RECORD		AGENCY			REMARKS
					M	C/N				*	**			
1	2	3	4	5	6		7	8	9	D	M	C	N	
		3. Sequence, lay length & Direction	MA	Visual, Meas	one Sample of each size/lot	-	Mfrs Std	Mfrs Std.	-do-	√	P	-	-	
		4. Surface Finish	MA	Visual	100%	-	Surface shall be smooth	Surface shall be smooth	-do-	√	P	-	-	
		5.Dimension	MA	Measurement	one Sample of each size/lot	-	Appd. Data Sheet	Appd. Data Sheet	-do-	√	P	-	-	
	Core Insulation (No repair permitted)	1. Surface finish	MA	Visual	100%	100%	Free from bulging	Free from bulging	Inspection report	√	P	V	-	
		2 Insulation thickness	CR	Measurement	one Sample of each	-	Appd.data sheet	Appd.data sheet	-do-	√	P	-	-	

BHEL					
ENGINEERING			QUALITY		
Prepared by:	Sign & Date	Name	Checked by:	Sign & Date	Name
	<i>Devendra Singh</i>	DEVENDRA SINGH		<i>Kunal Gandhi</i>	KUNAL GANDHI
Reviewed by:	Sign & Date	Name	Reviewed by:	Sign & Date	Name
	<i>Manish Shukla</i>	MANISH SHUKLA		<i>R.K. Jaishwal</i>	R.K. JAISWAL
	28/02/2020			28/02/2020	

BIDDER/ SUPPLIER	
Sign & Date	
Seal	

FOR CUSTOMER REVIEW & APPROVAL			
Doc No:			
Reviewed by:	Sign & Date	Name	Seal
Approved by:			

	MANUFACTURER/ BIDDER/ SUPPLIER NAME & ADDRESS	STANDARD QUALITY PLAN			SPEC. NO : PE-TS-499-507-E003	DATE:
		CUSTOMER :			QP NO.: PE-QP-999-507-E003, R-1	DATE:
		PROJECT:			PO NO.:	DATE:
		ITEM: LLT PVC CONTROL CABLE 2.LT HR PVC CONTRL CABLE 3. LT PVC POWER CABLE 4. LT HRPVC POWER CABLE	SYSTEM:		SECTION: II	SHEET 10 OF 17

Sl. No.	COMPONENTS & OPERATIONS	CHARACTERISTICS	CLASS	TYPE OF CHECK	QUANTUM OF CHECK		REFERENCE DOCUMENT	ACCEPTANCE NORMS	FORMAT OF RECORD		AGENCY			REMARKS
					M	C/N			7	8	9	*	**	

					size/lot									
		3. Concentricity #	CR	Measurement	-do-	-do-	Mfrs Std	Mfrs Std	Inspection Report	√	P	V	-	# To be checked at starting & finish end of Extruded Length
		4 Dia over insulation	MA	Measurement	-do-	-	Approved Data Sheet	Approved Data Sheet	-do-	√	P	-	-	
		5. Core identification	MA	Visual	100%	-	Appd. Data Sheet	Appd. Data Sheet	-do-	√	P	-	-	
		6. TS & % Elongation	MA	Mechanical	100%	-	IS 1554 Pt-1/ IS 5831	IS 1554 Pt-1/ IS 5831	-do-	√	P	-	-	

BHEL					
ENGINEERING			QUALITY		
Prepared by:	Sign & Date	Name	Checked by:	Sign & Date	Name
	<i>Devendra Singh</i>	DEVENDRA SINGH		<i>Kunal Gandhi</i>	KUNAL GANDHI
Reviewed by:	<i>Manish</i>	MANISH SHUKLA	Reviewed by:	<i>R.K. Jaishwal</i>	R.K. JAISWAL
	28/02/2020			28/2/2020	

BIDDER/ SUPPLIER	
Sign & Date	Seal

FOR CUSTOMER REVIEW & APPROVAL			
Doc No:	Sign & Date	Name	Seal
Reviewed by:			
Approved by:			

	MANUFACTURER/ BIDDER/ SUPPLIER NAME & ADDRESS	STANDARD QUALITY PLAN			SPEC. NO : PE-TS-499-507-E003	DATE:
		CUSTOMER :			QP NO.: PE-QP-999-507-E003, R-1	DATE:
		PROJECT:			PO NO.:	DATE:
		ITEM: I.LT PVC CONTROL CABLE 2.LT HR PVC CONTRL CABLE 3. LT PVC POWER CABLE 4. LT HRPVC POWER CABLE	SYSTEM:	SECTION: II	SHEET 11 OF 17	

SI. No.	COMPONENTS & OPERATIONS	CHARACTERISTICS	CLASS	TYPE OF CHECK	QUANTUM OF CHECK		REFERENCE DOCUMENT	ACCEPTANCE NORMS	FORMAT OF RECORD		AGENCY			REMARKS
					M	C/N				*	**	M	C	

		7. Spark Test or Water immersion test	CR	Electrical	100%	-	Mfr's Std.	Mfr's Std.	-do-	√	P	-	-	
Core laying		1. Dia over laid up core	MA	Measurement	one Sample of each size/lot	-	Approved Data Sheet	Approved Data Sheet	-do-	√	P	-	-	
		2. Sequence of lay and lay length & direction for laid up core	MA	Visual meas	one Sample of each size/lot	-	IS 1554 Pt-1	IS 1554 Pt-	-do-	√	P	-	-	
		3.Core identification	CR	Visual	one Sample of each size/lot	-	Appd. Data Sheet	Appd. Data Sheet	-do-	√	P	-	-	

BHEL					
ENGINEERING			QUALITY		
	Sign & Date	Name		Sign & Date	Name
Prepared by:	<i>Devendra Singh</i>	DEVENDRA SINGH	Checked by:	<i>Kunal Gandhi</i>	KUNAL GANDHI
Reviewed by:	<i>Manish Shukla</i>	MANISH SHUKLA	Reviewed by:	<i>R.K. Jaishwal</i>	R.K. JAISWAL

BIDDER/ SUPPLIER	
Sign & Date	
Seal	

FOR CUSTOMER REVIEW & APPROVAL			
Doc No:			
	Sign & Date	Name	Seal
Reviewed by:			
Approved by:			

	MANUFACTURER/ BIDDER/ SUPPLIER NAME & ADDRESS	STANDARD QUALITY PLAN				SPEC. NO : PE-TS-499-507-E003	DATE:
	CUSTOMER :					QP NO.: PE-QP-999-507-E003, R-1	DATE:
	PROJECT:					PO NO.:	DATE:
	ITEM: I.LT PVC CONTROL CABLE 2.LT HR PVC CONTRL CABLE 3. LT PVC POWER CABLE 4. LT HRPVC POWER CABLE	SYSTEM:					SECTION: II

SI. No.	COMPONENTS & OPERATIONS	CHARACTERISTICS	CLASS	TYPE OF CHECK	QUANTUM OF CHECK		REFERENCE DOCUMENT	ACCEPTANCE NORMS	FORMAT OF RECORD		AGENCY			REMARKS
					M	C/N			9	*	**	M	C	

Inner Sheath Extrusion (if applicable)	1. Surface finish	MA	Visual	100%	-	Surface shall be smooth	Surface shall be smooth	-do-	√	P	-	-	
	2. Sheath thickness	CR	Measurement	One sample of each size/lot	-	Approved Data Sheet	Approved Data Sheet	-do-	√	P	-	-	
	3. Dia over inner sheath	MA	Measurement	-do-	-	Approved Data Sheet	Approved Data Sheet	-do-	√	P	-	-	
Armouring (if applicable)	1. No. of wires/Strips	MA	Counting	At the start of the process	-	Mfr's Std	Mfr's Std	-do-	√	P	-	-	
	2. Lay Direction	MA	Visual	-do-	-	IS 1554 Pt-1	IS 1554 Pt-1	-do-	√	P	-	-	

BHEL					
ENGINEERING			QUALITY		
Prepared by:	Sign & Date	Name	Checked by:	Sign & Date	Name
Devedra Singh	<i>[Signature]</i>	DEVENDRA SINGH	<i>[Signature]</i>	28/12/20	KUNAL GANDHI
Manish Shukla	<i>[Signature]</i>	MANISH SHUKLA	<i>[Signature]</i>	28/12/20	R.K. JAISWAL

BIDDER/ SUPPLIER	
Sign & Date	Seal

FOR CUSTOMER REVIEW & APPROVAL			
Doc No:	Sign & Date	Name	Seal
Reviewed by:			
Approved by:			

	MANUFACTURER/ BIDDER/ SUPPLIER NAME & ADDRESS	STANDARD QUALITY PLAN			SPEC. NO. : PE-TS-499-507-E003	DATE:
		CUSTOMER :			QP NO.: PE-QP-999-507-E003, R-1	DATE:
		PROJECT:			PO NO.:	DATE:
		ITEM: 1.LT PVC CONTROL CABLE 2.LT HR PVC CONTRL CABLE 3. LT PVC POWER CABLE 4. LT HRPVC POWER CABLE	SYSTEM:	SECTION: II	SHEET 13 OF 17	

SI. No.	COMPONENTS & OPERATIONS	CHARACTERISTICS	CLASS	TYPE OF CHECK	QUANTUM OF CHECK		REFERENCE DOCUMENT	ACCEPTANCE NORMS	FORMAT OF RECORD		AGENCY			REMARKS
					M	C/N			9	*	**	M	C	

		3. Lay Length	MA	Visual, Meas.	At the start of the process	-	IS 1554 Pt-1	IS 1554 Pt-1	-do-	√	P	-	-	
		4. Coverage	MA	Measurement	-do-	-	Approved data sheet	Approved data sheet	-do-	√	P	-	-	
		5. Dia over armouring	MA	Measurement	-do-	-	Appd. Data Sheet	Appd. Data Sheet	-do-	√	P	-	-	
	Outer Sheath Extrusion	1. Surface Finish	MA	Visual	100%	-	Surface shall be smooth	Surface shall be smooth	-do-	√	P	-	-	
		2. Sheath thickness	CR	Measurement	One sample of each size/lot	-	Appd. Data Sheet	Appd. Data Sheet	-do-	√	P	-	-	

BHEL					
ENGINEERING			QUALITY		
	Sign & Date	Name		Sign & Date	Name
Prepared by:	<i>Devendra Singh</i>	DEVENDRA SINGH	Checked by:	<i>Kunal Gandhi</i>	KUNAL GANDHI
Reviewed by:	<i>Manish Shukla</i>	MANISH SHUKLA	Reviewed by:	<i>R.K. Jaiswal</i>	R.K. JAISWAL

29/02/2020

BIDDER/SUPPLIER	
Sign & Date	
Seal	

FOR CUSTOMER REVIEW & APPROVAL			
Doc No:			
	Sign & Date	Name	Seal
Reviewed by:			
Approved by:			

	MANUFACTURER/ BIDDER/ SUPPLIER NAME & ADDRESS	STANDARD QUALITY PLAN			SPEC. NO. : PE-TS-499-507-E003	DATE:
		CUSTOMER :			QP NO.: PE-QP-999-507-E003, R-1	DATE:
		PROJECT:			PO NO.:	DATE:
		ITEM: 1.LT PVC CONTROL CABLE 2.LT HR PVC CONTRL CABLE 3. LT PVC POWER CABLE 4. LT HRPVC POWER CABLE	SYSTEM:		SECTION: II	SHEET 14 OF 17

Sl. No.	COMPONENTS & OPERATIONS	CHARACTERISTICS	CLASS	TYPE OF CHECK	QUANTUM OF CHECK		REFERENCE DOCUMENT	ACCEPTANCE NORMS	FORMAT OF RECORD		AGENCY			REMARKS
					M	C/N			9	*	**	M	C	

		3. Dia over outer sheath	MA	Measurement	One sample of each size/lot	-	Appd. Data Sheet	Appd. Data Sheet	-do-	√	P	-	-	
		4. Marking/ Colour / Embossing	MA	Visual	One sample of each size/lot	-	Appd. Data Sheet	Appd. Data Sheet	-do-	√	P	-	-	
	Final Inspection (Internal)	1.Routine Test (Refer Note-H)	CR	Electrical Test & measurement	100%	100%	IS 1554-I & Appd. Datasheet	IS 1554-I & Appd. Datasheet	Test Report	√	P	V	√	#: Refer Annexure-A to QP
	Final Inspection	1. Finish	MA	Visual, Measurement	See Remark	See Remark	IS 1554 Pt-1/ Appd. Data Sheet	Free from Bulging, Burnt particles, lumps, cuts & scratches/ Approved data sheet	Test Report	√	P	W	W	

BHEL				
ENGINEERING		QUALITY		
Prepared by:	Sign & Date	Name	Checked by:	Name
	<i>Devendra Singh</i>	DEVENDRA SINGH	<i>Kunal Gandhi</i>	KUNAL GANDHI
Reviewed by:	<i>Manish Shukla</i>	MANISH SHUKLA	<i>R.K. Jaiswal</i>	R.K. JAISWAL

BIDDER/ SUPPLIER	
Sign & Date	
Seal	

FOR CUSTOMER REVIEW & APPROVAL			
Doc No:			
Reviewed by:	Sign & Date	Name	Seal
Approved by:			

28/02/2020

28/2/2020

	MANUFACTURER/ BIDDER/ SUPPLIER NAME & ADDRESS	STANDARD QUALITY PLAN				SPEC. NO.: PE-TS-499-507-E003		DATE:	
		CUSTOMER :				QP NO.: PE-QP-999-507-E003, R-1		DATE:	
		PROJECT:				PO NO.:		DATE:	
		ITEM I.LT PVC CONTROL CABLE		SYSTEM:		SECTION: II		SHEET 15 OF 17	
2.LT HR PVC CONTRL CABLE		3. LT PVC POWER CABLE		4. LT HRPVC POWER CABLE					

Sl. No.	COMPONENTS & OPERATIONS	CHARACTERISTICS	CLASS	TYPE OF CHECK	QUANTUM OF CHECK		REFERENCE DOCUMENT	ACCEPTANCE NORMS	FORMAT OF RECORD		AGENCY			REMARKS
					M	C/N			9	*	D	**	M	

2. Length	MA	Visual, Measurement	See Remark	See Remark	IS 1554 Pt-1/ Appd. Data Sheet	BHEL Spec./ Data Sheet	Test Report	√	P	W	W	
2. Dimensions	MA	Measurement	As per IS	As per IS	IS 1554 Pt-1/ Appd. Data Sheet	Appd. Data sheet	Test Report	√	P	W	W	
3. Armouring - Coverage No.of Wires/Strips	MA	Visual & Meas.	-do-	-do-	IS 1554 Pt-1/ Appd. Data Sheet	IS 1554 Pt-1/ Appd. Data Sheet	Test Report	√	P	W	W	'Refer Annexure-I to QP for sampling plan.
4. Marking/Colour Coding	MA	Visual	-do-	-do-	IS 1554 Pt-1/ Appd. Data Sheet	IS 1554 Pt-1/ Appd. Data Sheet	Test Report	√	P	W	W	
6. Acceptance Tests (Refer Note-H)	CR	Phy & Elect. Tests FRLS Test	Sample #	Sample #	#:	#:	Test Report	√	P	W	W	

BHEL					
ENGINEERING			QUALITY		
Prepared by:	Sign & Date	Name	Checked by:	Sign & Date	Name
	<i>Devendra Singh</i>	DEVENDRA SINGH		<i>Kunal Gandhi</i>	KUNAL GANDHI
Reviewed by:	<i>Manish Shukla</i>	MANISH SHUKLA	Reviewed by:	<i>R.K. Jaishwal</i>	R.K. JAISWAL
	28/02/2020			28/02/2020	

BIDDER/ SUPPLIER	
Sign & Date	
Seal	

FOR CUSTOMER REVIEW & APPROVAL			
Doc No:			
Reviewed by:	Sign & Date	Name	Seal
Approved by:			

	MANUFACTURER/ BIDDER/ SUPPLIER NAME & ADDRESS	STANDARD QUALITY PLAN			SPEC. NO. : PE-TS-499-507-E003	DATE:
		CUSTOMER :			QP NO.: PE-QP-999-507-E003, R-1	DATE:
		PROJECT:			PO NO.:	DATE:
		ITEM: LLT PVC CONTROL CABLE 2.LT HR PVC CONTRL CABLE 3. LT PVC POWER CABLE 4. LT HRPVC POWER CABLE	SYSTEM:		SECTION: II	SHEET 16 OF 17

Sl. No.	COMPONENTS & OPERATIONS	CHARACTERISTICS	CLASS	TYPE OF CHECK	QUANTUM OF CHECK		REFERENCE DOCUMENT	ACCEPTANCE NORMS	FORMAT OF RECORD		AGENCY			REMARKS
					M	C/N			9	D	M	C	N	
1	2	3	4	5	6	7	8	9	*	**				
		7. Type & FRLS Tests (Refer Note-H)	CR	Measurement	sample	sample	#:	#:	Test Report	√	P	W	W	
	Packing	Sealing Identification	MA	Visual	100%	100%	As per IS	As per IS	Test Report	√	P	W	-	

- NOTES: -
- (A) JOINTS IN WIRE SHALL BE AS PERMITTED BY MFRS STANDARD. VENDOR TO CERTIFY THE SAME.
 - (B) NO REPAIR OF CORE INSULATION PERMITTED
 - (C) CABLE ENDS SHALL BE SEALED AS PER VENDOR'S SPECIFICATION.
 - (D) RECORD OF RAW MATERIAL, PROCESS & ALL STAGES SHALL BE CERTIFIED BY VENDORS QC. AND ARE LIABLE TO AUDIT CHECK BY PURCHASER.
 - (E) FILLERS/DUMMY CORES ETC. SHALL BE AS PER APPROVED DATA SHEET
 - (F) WHEREVER EXTENT OF CHECK FOR STAGE IS MENTIONED AS 'SAMPLE' & NOT DEFINED IN QP, THE SAME SHALL BE AS PER VENDORS SAMPLING PLAN.
 - (G) VENDOR SHALL FURNISH COMPLIANCE CERTIFICATE TO THE INSPECTION AGENCY CONFIRMING THE PACKING AS PER IS/ BHEL SPECIFICATION.
 - (H) FOR LISTS OF ROUTINE TESTS, ACCEPTANCE TESTS & TYPE TESTS REFER ANNEXURE TO QAP.

BHEL				BIDDER/ SUPPLIER		FOR CUSTOMER REVIEW & APPROVAL			
ENGINEERING		QUALITY		Sign & Date		Doc No:			
Prepared by:	Sign & Date	Name	Checked by:	Sign & Date	Name	Reviewed by:	Sign & Date	Name	Seal
	<i>Devendra Singh</i>	DEVENDRA SINGH		<i>Kunal Gandhi</i>	KUNAL GANDHI				
Reviewed by:	<i>Manish Shukla</i>	MANISH SHUKLA	Reviewed by:	<i>R.K. Jaishwal</i>	R.K. JAISWAL	Approved by:			
	28/02/2020			24/2/2020					

	MANUFACTURER/ BIDDER/ SUPPLIER NAME & ADDRESS	STANDARD QUALITY PLAN		SPEC. NO : PE-TS-499-507-E003	DATE:
		CUSTOMER :		QP NO.: PE-QP-999-507-E003, R-1	DATE:
		PROJECT:		PO NO.:	DATE:
		ITEM: LLT PVC CONTROL CABLE 2.LT HR PVC CONTRL CABLE 3. LT PVC POWER CABLE 4. LT HRPVC POWER CABLE	SYSTEM:	SECTION: II	SHEET 17 OF 17

Sl. No.	COMPONENTS & OPERATIONS	CHARACTERISTICS	CLASS	TYPE OF CHECK	QUANTUM OF CHECK		REFERENCE DOCUMENT	ACCEPTANCE NORMS	FORMAT OF RECORD		AGENCY	REMARKS
					M	C/N			*	**		
1	2	3	4	5	6		7	8	9	D	M C N	

- (I) BHEL RESERVES THE RIGHT FOR CONDUCTING REPEAT TEST, IF REQUIRED.
- (J) AFTER PACKING AND PRIOR TO ISSUE OF MDCC, PHOTOGRAPHS OF COMPLETE CABLE (TO BE DISPATCHED) SHALL BE SENT TO BHEL-PURCHASE GROUP FOR REVIEW.
- (K) PROJECT SPECIFIC QP SHALL BE DEVELOPED BASED ON CUSTOMER REQUIREMENT.

LEGENDS:
 *RECORDS, IDENTIFIED WITH "TICK"(√) SHALL BE ESSENTIALLY INCLUDED BY SUPPLIER IN QA DOCUMENTATION,
 ** M: SUPPLIER/ MANUFACTURER/ SUB-SUPPLIER, C: MAIN SUPPLIER/ BHEL/ THIRD PARTY INSPECTION AGENCY, N: CUSTOMER,
 P: PERFORM, W: WITNESS, V: VERIFICATION, AS APPROPRIATE
 MA: MAJOR, MI: MINOR, CR: CRITICAL, D: DOCUMENTATION

BHEL					BIDDER/ SUPPLIER		FOR CUSTOMER REVIEW & APPROVAL			
ENGINEERING			QUALITY		Sign & Date		Doc No:			
Prepared by:	Sign & Date	Name	Checked by:	Sign & Date	Name	Seal		Sign & Date	Name	Seal
Reviewed by:	<i>Manish</i>	MANISH SHUKLA	Reviewed by:	<i>R.K.</i>	R.K. JAISWAL					
	<i>28/02/2020</i>			<i>28/2/2020</i>						

	ANNEXURE-I TO QP	CUSTOMER:	PROJECT TITLE	SPECIFICATION NUMBER: PE-TS-499-507-E003
		BIDDER/VENDOR:	QUALITY PLAN NUMBER : PE-QP-999-507-E003_R1	SPECIFICATION TITLE:
	SYSTEM	ITEM: 1. LT PVC CONTROL CABLE 2. LT HRPVC CONTROL CABLE 3. LT PVC POWER CABLE 4. LT HRPVC POWER CABLE	DOC. NO.	

TYPE/ ACCEPTANCE/ ROUTINE TEST REQUIREMENTS

A. Type Test Conduction:

1. Tests for which "T" is indicated in the 'Test Conduction Required As' column below shall be conducted as Type Test.
2. Sampling:
 - a) Type test to be conducted on one size of cable for every lot of cable.
 - b) FRLS & Flammability Test to be conducted only on one sample/ lot.

B. Acceptance Test Conduction:

1. Tests for which "A" is indicated in the 'Test Conduction Required As' column below shall be conducted as Acceptance tests.
2. Sampling:
Sampling for acceptance tests shall be as per Appendix-B of IS: 1554 Part-I (control cable).
3. Flammability Test to be conducted only on one sample/ lot.

C. Routine Test Conduction:





1. Tests for which "R" is indicated in the 'Test Conduction Required As' column below shall be conducted as Routine tests.

- D. Tests listed in S. No-7.0 & 8.0 shall be conducted only on one sample / lot.

NOTE

LOT shall be defined as per IS: 1554 Part-I (control cable).

S. No.	TEST	APPLICABLE FOR	TEST CONDUCTION REQUIRED AS	REFERENCE STANDARD	REMARKS
1.0	Tests for Conductor				
I.	Annealing test	For copper conductor	T, A	IS 10810 Pt 1	<i>In process records shall be furnished to inspector at the time of inspection.</i>
II.	Resistance test	For copper conductor	T, A, R	IS 10810 Pt 5	
2.0	Tests for Armour Wires/Strips				
I.	Measurement of dimensions	Applicable for GS wire/Strip	T,A	IS 10810 Pt 36	
II.	Tensile test	Applicable for GS wire/Strip	T, A	IS 10810 Pt 37	

BHEL					
ENGINEERING			QUALITY		
	Sign & Date	Name		Sign & Date	Name
Prepared by:		DEVENDRA SINGH	Checked by:		KUNAL GANDHI
Reviewed by:		MANISH SHUKLA	Reviewed by:		R.K. JAISWAL





BIDDER/ SUPPLIER	
Sign & Date	Seal

FOR CUSTOMER REVIEW & APPROVAL			
Doc No:	Sign & Date	Name	Seal
Reviewed by:			
Approved			

1780509/2023/PS-PEM-EL

	ANNEXURE-I TO QP	CUSTOMER:	PROJECT TITLE	SPECIFICATION NUMBER: PE-TS-499-507-E003
		BIDDER/VENDOR:	QUALITY PLAN NUMBER : PE-QP-999-507-E003_R1	SPECIFICATION TITLE:
	SYSTEM	ITEM: 1. LT PVC CONTROL CABLE 2. LT HRPVC CONTROL CABLE 3. LT PVC POWER CABLE 4. LT HRPVC POWER CABLE	DOC. NO.	

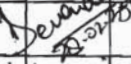
S. No.	TEST	APPLICABLE FOR	TEST CONDUCTION REQUIRED AS	REFERENCE STANDARD	REMARKS
III.	Elongation at break test	Applicable for GS wire/Strip only	T, A	IS 10810 Pt 37	
IV.	Torsion test	For GS round wire only	T, A	IS 10810 Pt 38	
V.	Winding / Adhesion Test	For GS strip only	T, A	IS 10810 Pt 39	
VI.	Resistivity test	Applicable for GS wire/Strip	T, A	IS 10810 Pt 42	
VII.	Uniformity of Zinc coating test	For G. S. wires/Strip only	T, A	IS 10810 Pt 40	
VIII.	Mass of Zinc coating test	For G. S. wires/Strip only	T, A	IS 10810 Pt 41	
IX.	Wrapping Test	For G. S. wires/Strip only	A	IS 10810 Pt 3	
3.0	Physical Tests for PVC Insulation & PVC sheath				
I.	Test for thickness	Applicable for PVC insulation, PVC inner sheath & PVC outer sheath	T, A	IS 10810 Pt 6	
II.	Tensile strength and elongation test at break	Applicable for PVC insulation & PVC outer sheath			
(a)	Before ageing		T, A	IS 10810 Pt 7	
(b)	After ageing		T, A	IS 10810 Pt 7	
III.	Ageing in air oven	Applicable for PVC insulation & PVC outer sheath	T	IS 10810 Pt 11	
IV.	Loss of mass in air oven test	Applicable for PVC insulation & PVC outer sheath	T	IS 10810 Pt 10	
V.	Hot deformation test	Applicable for PVC insulation & PVC outer sheath	T	IS 10810 Pt 15	
VI.	Heat shock test	Applicable for PVC insulation & PVC outer sheath	T	IS 10810 Pt 14	
VII.	Shrinkage test	Applicable for PVC insulation & PVC outer sheath	T	IS 10810 Pt 12	
VIII.	Thermal stability test	Applicable for PVC insulation & PVC outer sheath	T	IS 10810 Pt 60	
4.0	Improved Fire performance (FR-LSH) Tests				
I.	Oxygen index test	For PVC outer sheath only	T, A	IS 10810 Pt 58 / ASTM D 2863	Applicable for Inner Sheath also, if the same is indicated in Datasheet.
II.	Smoke density test	For PVC outer sheath only	T, A	IS 10810 Pt 63 / ASTM D 2843	
III.	Acid gas generation test	For PVC outer sheath only	T, A	IS 10810 Pt 59 / IEC-754-1	
IV.	Temperature Index Test	For PVC outer sheath only	T	IS 10810 Pt 64 / ASTM D 2863	

BHEL				
ENGINEERING			QUALITY	
	Sign & Date	Name	Sign & Date	Name
Prepared by:		DEVENDRA SINGH	Checked by:	 KUNAL GANDHI
Reviewed by:		MANISH	Reviewed by:	 R.K.

BIDDER/ SUPPLIER	
Sign & Date	
Seal	



FOR CUSTOMER REVIEW & APPROVAL			
Doc No:			
	Sign & Date	Name	Seal
Reviewed by:			
Approved			

	ANNEXURE-I TO QP	CUSTOMER:	PROJECT TITLE	SPECIFICATION NUMBER: PE-TS-499-507-E003
		BIDDER/VENDOR:	QUALITY PLAN NUMBER : PE-QP-999-507-E003_R1	SPECIFICATION TITLE:
	SYSTEM	ITEM	1. LT PVC CONTROL CABLE 2. LT HRPVC CONTROL CABLE 3. LT PVC POWER CABLE 4. LT HRPVC POWER CABLE	DOC. NO.

S. No.	TEST	APPLICABLE FOR	TEST CONDUCTION REQUIRED AS	REFERENCE STANDARD	REMARKS
5.0	Flammability Tests				
I.	Flammability test for bunched cables	For complete cable	T	IS 10810 Pt 62/ IEC-60332 (Part-3-23-Cat-B)	Test & Category applicable as indicated in Datasheet
II.	Flammability test for single cable	For complete cable	T,A	IS: 10810 Pt 61 / IEC:60332 Part-1	
III.	Swedish chimney test	For complete cable	A	SEN SS 424 1475 (Class F3)	
IV.	Flammability test	For complete cable	A	IEEE: 60383	
6.0	Electrical Tests				
I.	High Voltage Test (Water immersion test)	On cores	T	IS 10810 Pt 45	
II.	High Voltage Test at room temperature	For complete cable	T, A, R	IS 10810 Pt 45	
III.	Insulation Resistance Test (Volume resistivity method)	For complete cable	T, A	IS 10810 Pt 43	
7.0	Anti-rodent and Termite Repulsion test	For PVC outer sheath only	A	Refer Note	Test applicable if indicated in Datasheet
8.0	Anti-Fungal Test	For PVC outer sheath only	A	--	
9.0	Special Tests				
I.	Hydrolytic Stability Test	For complete cable	**	ASTM D 3137:81	Test applicable if indicated in Datasheet
II.	Ultraviolet Radiation Test	For complete cable	**	BS EN ISO 4892-2	

**** These tests shall be conducted on one sample for the entire contract and duration of these tests shall be 14 days.**

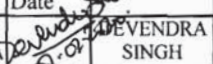
Note: A few chipping of the PVC compound is slowly ignited on a porcelain dish or cubicle in a muffle furnace at about 600 degree C. The resulting ignited ash is boiled with a little ammonium acetate solution (10%). Place a drop of aqueous sodium sulphide solution on a thick filter paper and allow soaking. Touch the spot with a drop of above extract. A black spot indicates the presence of lead, the anti-termite and rodent compound.

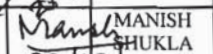
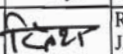
BHEL					
ENGINEERING			QUALITY		
	Sign & Date	Name		Sign & Date	Name
Prepared by:		DEVENDRA SINGH	Checked by:		KUNAL GANDHI
Reviewed by:		MANISH SHUKLA	Reviewed by:		R.K. JAISWAL

BIDDER/ SUPPLIER	
Sign & Date	Seal

FOR CUSTOMER REVIEW & APPROVAL			
Doc No:	Sign & Date	Name	Seal
Reviewed by:			
Approved by:			

Ref: PW/PE/CMM-PVC Cables Packages (Rev-02)

Dated:19/02/2019

Note: Applicable for cable tenders released on or after 14/01/2019.

Price Variation Formulae for cables -Annexure-I

1. Prices shall be variable as per price variation formulae given below (basis IEEMA).
The price variation shall be limited to + 20% of total ex-works price actually supplied (cable size wise) and -ve price variation shall be unlimited. Rates for working out price variation shall be as per rates published by IEEMA for the factors given in Annexure-II

2. Base date for prices:

Initial Price (As per IEEMA) for-Alo, Cuo, CCo, PVCCo & Feo:

Base Date shall be- 1st working day of the previous month to the date of issue of tender enquiry.

Final Price (as per IEEMA) for- Al, Cu, Cc, PVCC & Fe:

1st working day of month, one month prior to the date on which cable is notified as being ready for inspection i.e TPIA inspection call raise date on web portal.

3. Variation factor value for ALF, CuF, CCFAL, CCFCu, XLFAL, XLFCu, FeF & FeW as applicable shall be as per Technical Specification.

4. PVC shall be payable within contractual delivery period (including any extension thereto).

IEEMA table for Price variation cause for various type of cable

1. Aluminium conductor cable

S.No	Cable Type	AIF (Single core unarmoured & Multi core armoured)	AIF (Single core armoured)	CCFAI	XLFAL (Single core)	XLFAL (Multi core)	FeF	FeW	IEEMA Formula
1.	HT XLPE Power cable	ALP	H1	H2	XL3	XL4	H3	H5	$P=Po+AIF(AL-Alo) + XLFAL(CC-CCo) +CCFAI(PVCC-PVCCo) + FeF(Fe-Feo)$
2.	LT XLPE Power Cable	ALP	P1	L2	XL1	XL1	P3	P3 (Additional)	$P=Po+AIF(AL-Alo) + XLFAL(CC-CCo) +CCFAI(PVCC-PVCCo) + FeF(Fe-Feo)$
3.	LT PVC Power Cable	ALP	P1	P2	-	-	P3	P3 (Additional)	$P=Po+AIF(AL-Alo) + CCFAI(PVCC-PVCCo) + FeF(Fe-Feo)$
4.	LT HRPVC Power Cable	ALP	P1	P2	-	-	P3	P3 (Additional)	$P=Po+AIF(AL-Alo) + CCFAI(PVCC-PVCCo) + FeF(Fe-Feo)$

2. Copper conductor cable

S no.	Cable type	CuF	AIF (single core armoured)	CCFCu	XLFCU (Single core)	XLFCU (Multi core)	FeF	FeW	IEEMA Formula
1	HT XLPE Power cable	CUP	H4	H2	XL3	XL4	H3	H5	$P=Po+CuF(Cu-Cuo) + XLFCU(CC-CCo) +CCFCu(PVCC-PVCCo) + FeF(Fe-Feo) + AIF(AL-Alo)$
2	LT XLPE Power Cable	CUP	P4	L2	XL1	XL1	P3	P3 (Additional)	$P=Po+CuF(Cu-Cuo) + XLFCU(CC-CCo) + CCFCu (PVCC-PVCCo) + FeF(Fe-Feo) + AIF(AL-Alo)$

S no.	Cable type	CuF	AIF (single core armou red)	CCFCu	XLFCU (Single core)	XLFCU (Multi core)	FeF	FeW	IEEMA Formula
3	LT PVC Power Cable	CUP	P4	P2	--	--	P3	P3 (Addit ional)	$P=Po+CuF(Cu-Cuo)$ + CCFCu (PVCC- PVCCo) + FeF(Fe- Feo) + AIF(AL-Alo)
4	LT HRPVC Power Cable	CUP	P4	P2	--	--	P3	P3 (Addit ional)	$P=Po+CuF(Cu-Cuo)$ + CCFCu (PVCC- PVCCo) + FeF(Fe- Feo) + AIF(AL-Alo)
5	LT XLPE Control Cable	CUC	--	P5	--	XL2	P6	P6 (Addit ional)	$P=Po+CuF(Cu-Cuo)$ + XLFCU(CC-CCo) + CCFCu (PVCC- PVCCo) + FeF(Fe- Feo)
6	LT PVC Control Cable	CUC	--	P5	--	--	P6	P6 (Addit ional)	$P=Po+CuF(Cu-Cuo)$ + CCFCu (PVCC- PVCCo) + FeF(Fe- Feo)
7	LT HRPVC Control Cable	CUC	--	P5	--	--	P6	P6 (Addit ional)	$P=Po+CuF(Cu-Cuo)$ + CCFCu(PVCC- PVCCo) + FeF(Fe- Feo)
8	LT XLPE Fire Survival Power Cable	CUP	P4	L2	XL1	XL1	P3	P3 (Addit ional)	$P=Po+CuF(Cu-Cuo)$ + XLFCU(CC-CCo) + CCFCu (PVCC- PVCCo) + FeF(Fe- Feo) + AIF(AL-Alo)
9	LT XLPE Fire Survival Control	CUC	--	P5	--	XL2	P6	P6 (Addit ional)	$P=Po+CuF(Cu-Cuo)$ + XLFCU(CC-CCo) + CCFCu (PVCC- PVCCo) + FeF(Fe- Feo)
10	LT EPR Fire Survival Power Cable	CUP	P4	L2	--	--	P3	P3 (Addit ional)	$P=Po+CuF(Cu-Cuo)$ + CCFCu (PVCC- PVCCo) + FeF(Fe- Feo) + AIF(AL-Alo)
11	LT EPR Fire Survival Control cable	CUC	--	P5	--	--	P6	P6 (Addit ional)	$P=Po+CuF(Cu-Cuo)$ + CCFCu (PVCC- PVCCo) + FeF(Fe- Feo)
12	Screened control Cable (Overall screen)	Cu POS	--	--	--	--	Fe POS	Fe POS	$P=Po+CuF(Cu-Cuo)$ + FeF(Fe-Feo)
13	Screened control Cable (Individual	Cu PIS	--	--	--	--	Fe PIS	Fe PIS	$P=Po+CuF(Cu-Cuo)$ + FeF(Fe-Feo)

IEEMA Table for Price Variation Clause for various types of Cables

Notes:-

(i) Cu POS, Cu PIS, Fe POS & Fe PIS tables shall be as per IEEMA circular No. IEEMA (PVC) /Instrumentation Cable/2014 effective from dtd 01.07.2014.

(ii) All other tables shall be as per IEEMA circular No. 35//DIV/CAB/05/ dated 24.04.2018.

Terms used in PVC formulae:

P = Price payable as adjusted in accordance with above appropriate formula (In Rs./Km).

Po= Price quoted/confined (in Rs./km).

1. ALUMINIUM

ALF Variation factor for aluminium.

Al =Price of aluminium.

Alo = Price of aluminium.

2 COPPER

CuF =Variation factor for copper.

Cu = Price of CC copper rods.

Cuo = Price of CC copper rods.

3.PVCC COMPOUND/POLYMER

PVCC = Price of PVC compound.

PVCCo= Price of PVC compound.

CCFAL= Variation factor for PVC compound/Polymer for aluminium conductor cable.

CCFCu =Variation factor for PVC compound/Polymer for copper conductor cable.

4. XLPE COMPOUND

Cc = Price of XLPE compound.

Cco= Price of XLPE compound.

XLFAL= Variation factor for XLPE compound for aluminium conductor cable.

XLFCu =Variation factor for XLPE compound for copper conductor cable.

5.STEEL

Fe= Price of steel strips/steel wire.

Feo= Price of steel strips/steel wire.

FeF =Variation factor for steel.

FeW=Variation factor for round wire steel armouring.



501, Kakad Chambers
132, Dr. Annie Besant Road, Worli
Mumbai 400018
India

P: +91 22 2493 0532
F: +91 22 2493 2705
E: mumbai@ieema.org
www.ieema.org

IEEMA (PVC)/Instrumentation Cable/2014

Effective from: 1st July 2014

Material Price Variation Clause For Instrumentation Cables

The Price quoted/confirmed is based on the input cost of raw materials/components as on the date of quotation, and the same is deemed to be related to the prices of raw materials as specified in the price variation clause given below. In case of any variation in these prices, the price payable shall be subject to adjustment up or down in accordance with the formulae provided in this document.

Terms used in price variation formulae:

P Price payable as adjusted in accordance with above appropriate formula (in Rs/Km)

P₀ Price quoted/confirmed (in Rs/Km)

COPPER

CuF Variation factor for copper

Cu Price of CC copper rods. This price is as applicable on first working day of the month, one month prior to the date of delivery.

Cu₀ Price of CC copper rods. This price is as applicable on first working day of the month, one month prior to the date of tendering.

STEEL

FeF Variation factor for steel

Fe Price of Steel Strips/steel wire. This price is as applicable on the first working day of the month, one month prior to the date of delivery.

Fe₀ Price of steel strips/steel wire. This price is as applicable on first working day of the month, one month prior to the date of tendering.

The above prices and indices are as published by IEEMA vide Circular reference IEEMA(PVC)/CABLE/--/-- prevailing as on 1st working day of the month i.e. one month prior to the date of tendering.

The date of delivery is the date on which the cable is notified as being ready for inspection/dispatch (in the absence of such notification, the date of manufacturer's dispatch note is to be considered as the date of delivery) or the contracted delivery date (including any agreed extension thereto), whichever is earlier.

Page 1 of 2

New Delhi
Rishyamook Building, First Floor
85 A, Panchkuian Road
New Delhi 110001, India
P: +91 11 2336 3013/14
F: +91 11 2336 3015
E: delhi@ieema.org

Bangalore
204, Swiss Complex
33, Race Course Road
Bangalore 560001, India
P: +91 80 2220 1316/18
F: +91 80 2220 1317
E: bangalore@ieema.org

Kolkata
503 A, Oswal Chambers
2, Church Lane
Kolkata 700001, India
P: +91 33 6510 7855
F: +91 33 2213 1326
E: kolkata@ieema.org

Indian Electrical & Electronics Manufacturers' Association

IEEMA (PVC)/Instrumentation Cable/2014

Effective from: 1st July 2014

Notes

- (a) All prices of raw materials are exclusive of modvatable excise/CV duty amount and exclusive of any other central, state or local taxes, octroi, etc.
- (b) All Prices are as on first working day of the month.
- (c) The details of prices are as under:
 - 1. Price of CC copper rods (in Rs/MT) is ex-works price as quoted by the primary producer.
 - 2. Price of galvanized steel strip / steel wire (in Rs/MT) is ex-works price as quoted by the manufacturer for Round steel Wire and Flat steel strip (the relevant price of steel strip or steel wire is to be selected depending upon the type of armouring of the cable).

Price variation formula for 'Instrumentation Cables'

$$P = P_o + CuF (Cu - Cu_o) + FeF (Fe - Fe_o)$$

1. For Pair Instrumentation Over all Screen Cables

Tables References:

Cu POS Copper Factor
Fe POS Steel Factor

2. For Pair Instrumentation Individual and Over all Screen Cables

Tables References:

Cu PIS Copper Factor
Fe PIS Steel Factor

3. For Triad Instrumentation Over all Screen Cables

Tables References:

Cu TOS Copper Factor
Fe TOS Steel Factor

4. For Triad Instrumentation Individual & Overall Screen Cables

Tables References:

Cu TIS Copper Factor
Fe TIS Steel Factor

Deputy Director General
Page 2 of 2

Copper Factors for Instrumentation Cables - CuF

Cu POS

Pair Instrumentation Over all Screen Cables					
No. of Pairs Cable size in sq.mm	0.5 sq.mm	0.75 sq.mm	1.0 sq.mm	1.5 sq.mm	2.5 sq.mm
1	0.0142	0.0185	0.0233	0.0326	0.0500
2	0.0258	0.0345	0.0440	0.0625	0.0978
3	0.0353	0.0484	0.0626	0.0904	0.1433
4	0.0448	0.0623	0.0811	0.1183	0.1888
5	0.0578	0.0800	0.1022	0.1467	0.2356
6	0.0662	0.0926	0.1210	0.1768	0.2829
7	0.0756	0.1067	0.1378	0.2000	0.3245
8	0.0852	0.1204	0.1582	0.2327	0.3741
9	0.0933	0.1334	0.1734	0.2534	0.4134
10	0.1046	0.1485	0.1959	0.2893	0.4665
11	0.1111	0.1600	0.2089	0.3067	0.5023
12	0.1236	0.1764	0.2333	0.3452	0.5580
13	0.1289	0.1867	0.2445	0.3600	0.5912
14	0.1378	0.2000	0.2623	0.3867	0.6356
15	0.1467	0.2134	0.2800	0.4134	0.6801
16	0.1618	0.2322	0.3080	0.4573	0.7409
17	0.1645	0.2400	0.3156	0.4667	0.7690
18	0.1734	0.2534	0.3334	0.4934	0.8134
19	0.1822	0.2667	0.3512	0.5201	0.8579
20	0.1911	0.2800	0.3689	0.5467	0.9023
21	0.2000	0.2934	0.3867	0.5734	0.9468
22	0.2089	0.3067	0.4045	0.6001	0.9912
23	0.2178	0.3200	0.4223	0.6267	1.0357
24	0.2381	0.3437	0.4575	0.6813	1.1068
25	0.2356	0.3467	0.4578	0.6801	1.1246
26	0.2445	0.3600	0.4756	0.7068	1.1690
27	0.2534	0.3734	0.4934	0.7334	1.2135
28	0.2623	0.3867	0.5112	0.7601	1.2579
29	0.2711	0.4001	0.5290	0.7868	1.3024
30	0.2800	0.4134	0.5467	0.8134	1.3468
31	0.2889	0.4267	0.5645	0.8401	1.3913
32	0.2978	0.4401	0.5823	0.8668	1.4357
33	0.3067	0.4534	0.6001	0.8934	1.4802
34	0.3156	0.4667	0.6179	0.9201	1.5246
35	0.3245	0.4801	0.6356	0.9468	1.5691
36	0.3334	0.4934	0.6534	0.9735	1.6135
37	0.3423	0.5067	0.6712	1.0001	1.6580
38	0.3512	0.5201	0.6890	1.0268	1.7024
39	0.3600	0.5334	0.7068	1.0535	1.7469
40	0.3689	0.5467	0.7245	1.0801	1.7913
41	0.3778	0.5601	0.7423	1.1068	1.8358
42	0.3867	0.5734	0.7601	1.1335	1.8802
43	0.3956	0.5867	0.7779	1.1601	1.9247
44	0.4045	0.6001	0.7957	1.1868	1.9691
45	0.4134	0.6134	0.8134	1.2135	2.0136
46	0.4223	0.6267	0.8312	1.2402	2.0580
47	0.4312	0.6401	0.8490	1.2668	2.1025
48	0.4710	0.6759	0.9010	1.3410	2.2009

Copper Factors for Instrumentation Cables - CuF

Cu PIS

Pair Instrumentation Individual and Over all Screen Cables					
No. of Pairs Cable size in sq.mm	0.5 sq.mm	0.75 sq.mm	1.0 sq.mm	1.5 sq.mm	2.5 sq.mm
1	0.0133	0.0178	0.0222	0.0311	0.0489
2	0.0349	0.0437	0.0531	0.0717	0.1069
3	0.0490	0.0621	0.0763	0.1041	0.1570
4	0.0630	0.0806	0.0994	0.1389	0.2071
5	0.0800	0.1022	0.1245	0.1689	0.2578
6	0.0937	0.1200	0.1484	0.2042	0.3103
7	0.1067	0.1378	0.1689	0.2311	0.3556
8	0.1218	0.1569	0.1948	0.2692	0.4107
9	0.1334	0.1734	0.2134	0.2934	0.4534
10	0.1503	0.1943	0.2417	0.3349	0.5122
11	0.1600	0.2089	0.2578	0.3556	0.5512
12	0.1785	0.2313	0.2882	0.4001	0.6128
13	0.1867	0.2445	0.3023	0.4178	0.6490
14	0.2000	0.2623	0.3245	0.4489	0.6979
15	0.2134	0.2800	0.3467	0.4801	0.7468
16	0.2350	0.3053	0.3812	0.5305	0.8141
17	0.2400	0.3156	0.3912	0.5423	0.8446
18	0.2534	0.3334	0.4134	0.5734	0.8934
19	0.2667	0.3512	0.4356	0.6045	0.9423
20	0.2800	0.3689	0.4578	0.6356	0.9912
21	0.2934	0.3867	0.4801	0.6668	1.0401
22	0.3067	0.4045	0.5023	0.6979	1.0890
23	0.3200	0.4223	0.5245	0.7290	1.1379
24	0.3479	0.4535	0.5673	0.7911	1.2165
25	0.3467	0.4578	0.5690	0.7912	1.2357
26	0.3600	0.4756	0.5912	0.8223	1.2846
27	0.3734	0.4934	0.6134	0.8534	1.3335
28	0.3867	0.5112	0.6356	0.8846	1.3824
29	0.4001	0.5290	0.6579	0.9157	1.4313
30	0.4134	0.5467	0.6801	0.9468	1.4802
31	0.4267	0.5645	0.7023	0.9779	1.5291
32	0.4401	0.5823	0.7245	1.0090	1.5780
33	0.4534	0.6001	0.7468	1.0401	1.6269
34	0.4667	0.6179	0.7690	1.0712	1.6758
35	0.4801	0.6356	0.7912	1.1024	1.7247
36	0.4934	0.6534	0.8134	1.1335	1.7736
37	0.5067	0.6712	0.8357	1.1646	1.8225
38	0.5201	0.6890	0.8579	1.1957	1.8713
39	0.5334	0.7068	0.8801	1.2268	1.9202
40	0.5467	0.7245	0.9023	1.2579	1.9691
41	0.5601	0.7423	0.9246	1.2891	2.0180
42	0.5734	0.7601	0.9468	1.3202	2.0669
43	0.5867	0.7779	0.9690	1.3513	2.1158
44	0.6001	0.7957	0.9912	1.3824	2.1647
45	0.6134	0.8134	1.0135	1.4135	2.2136
46	0.6267	0.8312	1.0357	1.4446	2.2625
47	0.6401	0.8490	1.0579	1.4757	2.3114
48	0.6887	0.8936	1.1186	1.5587	2.4186

Steel Factors for Instrumentation Cables - FeF					
Fe POS					
Pair Instrumentation Over all Screen Cables					
No. of Pairs Cable size in sq.mm	0.5 sq.mm	0.75 sq.mm	1.0 sq.mm	1.5 sq.mm	2.5 sq.mm
1	0.1490	0.1565	0.1635	0.1735	0.1930
2	0.2190	0.2335	0.2470	0.2665	0.2595
3	0.2360	0.2545	0.2690	0.2900	0.2680
4	0.2390	0.2580	0.2715	0.2945	0.2830
5	0.2630	0.2820	0.2420	0.2805	0.3155
6	0.2840	0.3160	0.2805	0.2995	0.3430
7	0.2840	0.2595	0.2805	0.2995	0.3430
8	0.3235	0.2930	0.3030	0.3315	0.3780
9	0.2805	0.3180	0.3290	0.3590	0.4205
10	0.2970	0.3215	0.3455	0.3755	0.4385
11	0.3005	0.3255	0.3490	0.3805	0.4435
12	0.3055	0.3440	0.3680	0.3880	0.4520
13	0.3265	0.3530	0.3780	0.4105	0.4785
14	0.3265	0.3530	0.3780	0.4105	0.4785
15	0.3490	0.3765	0.4015	0.4365	0.5195
16	0.3490	0.3765	0.4015	0.4365	0.5195
17	0.3590	0.4005	0.4140	0.4635	0.5470
18	0.3590	0.4005	0.4265	0.4635	0.5470
19	0.3590	0.4005	0.4265	0.4635	0.5470
20	0.3830	0.4240	0.4535	0.4920	0.5760
21	0.3830	0.4240	0.4535	0.4920	0.5760
22	0.4065	0.4520	0.4785	0.5310	0.6190
23	0.4065	0.4520	0.4810	0.5310	0.6190
24	0.4305	0.4770	0.5070	0.5595	0.6475
25	0.4305	0.4770	0.5070	0.5595	0.6475
26	0.4305	0.4770	0.5070	0.5595	0.6475
27	0.4355	0.4820	0.5245	0.5660	0.6700
28	0.4570	0.5045	0.5345	0.5895	0.6950
29	0.4570	0.5045	0.5345	0.5895	0.6950
30	0.4570	0.5045	0.5345	0.5895	0.6950
31	0.4795	0.5285	0.5595	0.6150	0.7225
32	0.4820	0.5285	0.5595	0.6150	0.7225
33	0.4820	0.5285	0.5595	0.6150	0.7225
34	0.4920	0.5520	0.5835	0.6410	0.7500
35	0.4920	0.5520	0.5835	0.6410	0.7500
36	0.4920	0.5520	0.5835	0.6410	0.7500
37	0.4920	0.5520	0.5835	0.6410	0.7500
38	0.5145	0.5760	0.6225	0.6550	0.7805
39	0.5145	0.5760	0.6225	0.6550	0.7805
40	0.5145	0.5760	0.6225	0.6550	0.7805
41	0.5395	0.6025	0.6475	0.6975	0.8230
42	0.5395	0.6025	0.6475	0.6975	0.8230
43	0.5395	0.6025	0.6475	0.6975	0.8230
44	0.5635	0.6265	0.6735	0.7250	0.8540
45	0.5635	0.6265	0.6760	0.7250	0.8540
46	0.5635	0.6265	0.6760	0.7250	0.8540
47	0.5635	0.6265	0.6760	0.7250	0.8540
48	0.5635	0.6265	0.6760	0.7375	0.8665

Steel Factors for Instrumentation Cables - FeF

Fe PIS

Pair Instrumentation Individual and Over all Screen Cables

No. of Pairs Cable size in sq.mm	0.5 sq.mm	0.75 sq.mm	1.0 sq.mm	1.5 sq.mm	2.5 sq.mm
1	0.1880	0.1980	0.2070	0.2220	0.2410
2	0.2315	0.2460	0.2595	0.2815	0.2755
3	0.2505	0.2690	0.2820	0.2495	0.2830
4	0.2645	0.2830	0.2420	0.2805	0.3155
5	0.2895	0.2730	0.2805	0.3005	0.3430
6	0.2755	0.2980	0.3005	0.3280	0.3730
7	0.2755	0.2980	0.3005	0.3280	0.3730
8	0.2980	0.3215	0.3455	0.3740	0.4230
9	0.3230	0.3490	0.3730	0.4040	0.4685
10	0.3405	0.3655	0.3765	0.4215	0.4885
11	0.3430	0.3690	0.3815	0.4265	0.4945
12	0.3490	0.3765	0.4015	0.4470	0.5160
13	0.3715	0.3990	0.4255	0.4720	0.5420
14	0.3715	0.3990	0.4255	0.4720	0.5420
15	0.3955	0.4240	0.4510	0.5020	0.5720
16	0.3955	0.4240	0.4510	0.5020	0.5720
17	0.4190	0.4495	0.4795	0.5295	0.6150
18	0.4190	0.4495	0.4795	0.5295	0.6150
19	0.4190	0.4495	0.4795	0.5295	0.6150
20	0.4445	0.4770	0.5060	0.5570	0.6450
21	0.4445	0.4895	0.5060	0.5695	0.6450
22	0.4695	0.5045	0.5345	0.5870	0.6885
23	0.4695	0.5045	0.5345	0.5870	0.6885
24	0.4970	0.5310	0.5620	0.6285	0.7210
25	0.4970	0.5310	0.5620	0.6285	0.7210
26	0.4970	0.5310	0.5620	0.6285	0.7210
27	0.5035	0.5495	0.5810	0.6360	0.7410
28	0.5135	0.5610	0.6050	0.6610	0.7690
29	0.5135	0.5610	0.6050	0.6610	0.7690
30	0.5260	0.5610	0.6050	0.6610	0.7690
31	0.5495	0.5845	0.6300	0.6885	0.7990
32	0.5495	0.5845	0.6300	0.6885	0.7990
33	0.5495	0.5845	0.6300	0.6885	0.7990
34	0.5735	0.6225	0.6585	0.7285	0.8405
35	0.5735	0.6225	0.6585	0.7285	0.8405
36	0.5735	0.6225	0.6585	0.7285	0.8405
37	0.5735	0.6225	0.6585	0.7285	0.8405
38	0.5990	0.6485	0.6850	0.7575	0.8740
39	0.5990	0.6485	0.6850	0.7575	0.8740
40	0.5990	0.6485	0.6850	0.7575	0.8740
41	0.6250	0.6775	0.7135	0.7880	0.9180
42	0.6250	0.6775	0.7135	0.7880	0.9180
43	0.6250	0.6775	0.7135	0.7880	0.9180
44	0.6485	0.7050	0.7410	0.8165	0.9495
45	0.6485	0.7050	0.7410	0.8165	0.9495
46	0.6485	0.7050	0.7410	0.8165	0.9495
47	0.6485	0.7050	0.7410	0.8165	0.9495
48	0.6485	0.7050	0.7535	0.8290	0.9620



Indian Electrical & Electronics Manufacturer's Association
 501, Kakad Chambers P +91 22 2493 0532
 132, Dr. A. B. Road, Worli, F +91 22 2493 2705
 Mumbai - 400 018. E mumbai@ieema.org
 INDIA. W www.ieema.org

Cir. No. 35/DIV/CAB/05/

24th April 2018

To Members of the Cable Division, Utilities, Railways & Listed purchasing organizations

Sub: Correction in PV formulae of LT XLPE Power Cable and addition of factors for HT XLPE Power Cables

We have recently published revised Price Variation Clause for LT&HT XLPE Power Cables and made it effective from 1st November 2017 vide Cir. No.111/DIV/CAB/05 dated 5th December 2017

While replying to a query of a buyer it is observed that the polymer factor for LT XLPE Power Cables (both aluminium and copper) was incorrectly represented by Table P2.

We have now corrected the anomaly by correcting the PV formulae of LT XLPE Aluminium and Copper Insulated Cables (Sl. No. D & E) by representing Polymer factor by Table L2.

We have also worked out factors for XLPE, Copper and Steel for 3 core HT XLPE Power Cables for 500 and 630 sq.mm.

We now enclose complete PV clause of Cable by including all the PV formulae of different types of power cable (Sl. No. A to I), polymer factor Table L2 and updated XL4, H2 and H5 Table of factors for your perusal & record.

We request to replace PV clause of Cable already circulated vide Cir. 111/DIV/CAB/05 dated 5th December 2017 with the enclosed PV clause in your records for future use.

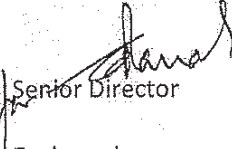
 Senior Director
 Encl: as above

prasad partners in implementation



HEAD OFFICE - DELHI
 Rishyamook Building, First Floor, 85 A, Panchkuian Road, New Delhi - 110001, INDIA.
 P +91 11 2336 3013 / 14 • F +91 11 2336 3015 • E delhi@ieema.org • W www.ieema.org



Indian Electrical & Electronics Manufacturer's Association
 501, Kakad Chambers P +91 22 2493 0532
 132, Dr. A. B. Road, Worli, F +91 22 2493 2705
 Mumbai - 400 018. E mumbai@ieema.org
 INDIA. W www.ieema.org

IEEMA (PVC)/CABLE(R-1)/2017

Effective from: 1st November 2017

Material Price Variation Clause For PVC And XLPE Insulated Cables

The Price quoted/confirmed is based on the input cost of raw materials/components as on the date of quotation, and the same is deemed to be related to the prices of raw materials as specified in the price variation clause given below. In case of any variation in these prices, the price payable shall be subject to adjustment up or down in accordance with the formulae provided in this document.

Terms used in price variation formulae:

P Price payable as adjusted in accordance with above appropriate formula (in Rs/Km)

Po Price quoted/confirmed (in Rs/Km)

ALUMINIUM

AIF Variation factor for aluminium

AI Price of Aluminium. This price is as applicable of first working day of the month, one month prior to the date of delivery.

Alo Price of aluminium. This price is as applicable on first working day of the month, one month prior to the date of tendering.

COPPER

CuF Variation factor for copper

Cu Price of CC copper rods. This price is as applicable on first working day of the month, one month prior to the date of delivery.

Cuo Price of CC copper rods. This price is as applicable on first working day of the month, one month prior to the date of tendering.

PVC COMPOUND

PVCc price of PVC compound. This price is as applicable on first working day of the month, one month prior to the date of delivery.

PVCco Price of PVC compound. This price is as applicable on first working day of the month, one month prior to the date of tendering.

CCFAI Variation factor for PVC compound/Polymer for aluminum conductor cable.

CCFCu Variation factor for PVC compound/Polymer for copper conductor cable.

proud partners in implementation



HEAD OFFICE - DELHI
 Rishyamook Building, First Floor, 85 A, Panchkuian Road, New Delhi - 110001, INDIA.
 P +91 11 2336 3013 / 14 • F +91 11 2336 3015 • E delhi@ieema.org • W www.ieema.org



Indian Electrical & Electronics Manufacturer's Association
 501, Kakad Chambers P +91 22 2493 0532
 132, Dr. A. B. Road, Worli, F +91 22 2493 2705
 Mumbai - 400 018. E mumbai@ieema.org
 INDIA. W www.ieema.org

**IEEMA (PVC)/CABLE(R-1)/2017
 XLPE COMPOUND**

Effective from: 1st November 217

Cc price of XLPE compound. This price is as applicable on first working day of the month, one month prior to the date of delivery.

Cco Price of XLPE compound. This price is as applicable on first working day of the month, one month prior to the date of tendering.

XLFAL Variation factor for XLPE compound for aluminum conductor cable.

XLFCU Variation factor for XLPE compound for Copper conductor cable.

STEEL

FeF Variation factor for steel

FeW Variation factor for round wire steel armouring

Fe Price of Steel Strips/steel wire. This price is as applicable on the first working day of the month, one month prior to the date of delivery.

Feo Price of steel strips/steel wire. This price is as applicable on first working day of the month, one month prior to the date of tendering.

The above prices and indices are as published by IEEMA vide Circular reference IEEMA (PVC)/CABLE R(1)/--/-- prevailing as on 1st working day of the month i.e. one month prior to the date of tendering.

The date of delivery is the date on which the cable is notified as being ready for inspection/dispatch (in the absence of such notification, the date of manufacturer's dispatch note is to be considered as the date of delivery) or the contracted delivery date (including any agreed extension thereto), whichever is earlier.

Notes

- (a) All prices of raw materials are exclusive of GST amount.
- (b) All prices excluding Aluminium & Copper are as on first working day of the month.
- (c) The details of prices are as under:
 1. Price of Aluminium is LME average Cash SELLER Settlement price of Primary Aluminium in US\$ per MT as published by London Metal Bulletin (LME) including Premium for Aluminium Ingot in US\$ per MT is converted in Indian Rs./MT.
 2. Price of PVC Compound (in Rs/MT) is the ex-works price, as quoted by the manufacturer.
 3. Price of XLPE Compound (in Rs/MT) is the ex-works price, as quoted by the manufacturer
 4. Price of CC copper rods (in Rs/MT) is ex-works price as quoted by the primary producer.
 5. Price of galvanized steel strip / steel wire (in Rs/MT) is ex-works price as quoted by the manufacturer for Round steel Wire and Flat steel strip (the relevant price of steel strip or steel wire is to be selected depending upon the type of armouring of the cable).

proud partners in implementation



HEAD OFFICE - DELHI

Rishyamook Building, First Floor, 85 A, Panchsukian Road, New Delhi - 110001, INDIA.

P +91 11 2336 3013 / 14 • F +91 11 2336 3015 • E delhi@ieema.org • W www.ieema.org



Indian Electrical & Electronics Manufacturer's Association
 501, Kakad Chambers P +91 22 2493 0532
 132, Dr. A. B. Road, Worli, F +91 22 2493 2705
 Mumbai - 400 018. E mumbai@ieema.org
 INDIA. W www.ieema.org

IEEMA (PVC)/CABLE(R-1)/2017

Effective from: 1st November 217

Price variation formulae for 'Power Cables'

A. Aluminum conductor PVC insulated 1.1 kV power cables

$$P = P_o + AIF (AL - ALo) + CCFAl (PVCc - PVCco) + FeF (Fe - Feo)$$

For unarmoured multicore cables (without steel armour); FeF = 0

Table References:

ALP	Aluminium conductor in single core unarmoured & multicore cables
P1	Aluminium conductor aluminium armour in single core armoured cables
P2	PVC compound
P3	Steel armour

B. Copper conductor PVC insulated 1.1 kV power cables

$$P = P_o + CuF (Cu - Cuo) + CCFCu (PVCc - PVCco) + FeF (Fe - Feo) + AIF (Al - ALo)$$

For steel armoured cables; AIF = 0 For aluminium armoured cables; FeF = 0

For unarmoured cables; FeF, AIF = 0

Tables References:

CUP	Copper conductor
P2	PVC compound
P3	Steel armour
P4	Aluminium armour

C. Copper conductor PVC insulated 1.1 kV control cables

$$P = P_o + CuF (Cu - Cuo) + CCFCu (PVCc - PVCco) + FeF (Fe - Feo)$$

For unarmoured cables; FeF = 0

Tables References:

CUC	Copper conductor
P5	PVC compound
P6	Steel armour

D. Aluminum conductor XLPE insulated 1.1 kV power cables

$$P = P_o + AIF (AL - ALo) + XLFAL(CC-Cco) + CCFAl (PVCc - PVCco) + FeF (Fe - Feo)$$

For unarmoured multicore cables (without steel armour); FeF = 0

Table References:

ALP	Aluminium conductor in single core unarmoured & multicore cables
P1	Aluminium conductor aluminium armour in single core armoured cables
L2	Polymer (CCFAl)
P3	Steel armour
XL1	XLPE Compound (XLFAL)

E. Copper conductor XLPE insulated 1.1 kV power cables

$$P = P_o + CuF (Cu - Cuo) + XLFCU (CC-Cco) + CCFCu (PVCc - PVCco) + FeF (Fe - Feo) + AIF (Al - ALo)$$

For steel armoured cables; AIF = 0 For aluminium armoured cables; FeF = 0

proud partners in implementation



HEAD OFFICE - DELHI

Rishyamook Building, First Floor, 85 A, Panchkuian Road, New Delhi - 110001, INDIA.

P +91 11 2336 3013 / 14 • F +91 11 2336 3015 • E delhi@ieema.org • W www.ieema.org

IEEMA (PVC)/CABLE(R-1)/2017Effective from: 1st November 217

For unarmoured cables; FeF, AIF = 0

Tables References:

CUP	Copper conductor
L2	Polymer (CCFCu)
P3	Steel armour
P4	Aluminium armour
XL1	XLPE Compound (XLFCu)

F. Copper conductor XLPE insulated 1.1 kV control cables

$$P = P_o + CuF (Cu - Cuo) + XLFCU (CC-Cco) + CCFCu (PVCc - PVCco) + FeF (Fe - Feo)$$

For unarmoured cables; FeF = 0

Tables References:

CUC	Copper conductor
P5	PVC compound
P6	Steel armour
XL2	XLPE Compound

G. For Aluminium conductor XLPE insulated 3.3 to 33 kV power cables

$$P = P_o + AIF (Al - Alo) + XLFAL (CC-Cco) + CCFAI (PVCc - PVCco) + FeF (Fe - Feo)$$

For unarmoured multicore cables (without steel armour); FeF = 0

Table References:

ALP	Aluminium conductor in single core unarmoured & multicore cables
H1	Aluminium conductor + aluminium armour in single core armoured cables
H2	Polymer
H3/H5	Steel armour (Flat/Round)
XL3/XL4	XLPE Compound (Single core /Multicore)

H. Copper conductor XLPE Insulated 3.3 to 33 kV power cables

$$P = P_o + CuF (Cu - Cuo) + XLFCU (CC-Cco) + CCFCu (PVCc - PVCco) + FeF (Fe - Feo) + AIF (Al - Alo)$$

For steel armoured cables; AIF = 0 For aluminium armoured cables; FeF = 0

For unarmoured cables; FeF, AIF = 0

Table References:

CUP	Copper conductor
H2	Polymer
H3/H5	Steel armour (Flat/Round)
H4	Aluminium armour
XL3/XL4	XLPE Compound (Single core /Multicore)

I. Copper conductor XLPE insulated 1.0 and 1.5 kV Solar PV DC cables

$$P = P_o + CuF (Cu - Cuo)$$

Table CUscd Copper Conductor



Authorized Signatory

proud partners in implementation



HEAD OFFICE - DELHI

Rishyamook Building, First Floor, 85 A, Panchkuian Road, New Delhi - 110001, INDIA.

P +91 11 2336 3013 / 14 • F +91 11 2336 3015 • E delhi@ieema.org • W www.ieema.org

IEEMA (PVC)/CABLE(R-1)/2017

Effective from: 1st November 217

TABLE ALP

VARIATION FACTOR FOR ALUMINIUM (AIF)
POWER CABLES WITH ALUMINIUM CONDUCTOR
(EXCLUDING SINGLE CORE ARMoured CABLES)

Nominal Cross Sectional Area (in Sq. mm.)	1 core	2 core	3 core	3.5 core	4 core
2.5	0.007	0.014	0.021	-	0.028
4	0.011	0.023	0.034	-	0.046
6	0.017	0.034	0.052	-	0.069
10	0.029	0.053	0.087	-	0.116
16	0.046	0.091	0.137	-	0.183
25/16	0.073	0.146	0.219	0.262	0.292
35/16	0.101	0.202	0.302	0.345	0.404
50/25	0.137	0.273	0.410	0.478	0.547
70/35	0.197	0.395	0.593	0.687	0.791
95/50	0.274	0.548	0.821	0.949	1.095
120/70	0.346	0.691	1.036	1.221	1.382
150/70	0.425	0.853	1.279	1.464	1.706
185/95	0.533	1.070	1.605	1.861	2.140
225/120	0.655	1.310	1.965	2.287	2.620
240/120	0.703	1.400	2.099	2.421	2.799
300/150	0.879	1.757	2.635	3.033	3.514
400/185	1.126	2.249	3.374	3.873	4.498
500	1.418	2.838	4.256	-	5.675
630	1.828	3.663	5.494	-	7.326
800	2.340	4.679	7.018	-	9.357
1000	2.951	5.890	8.834	-	11.779

IEEMA (PVC)/CABLE(R-1)/2017

Effective from: 1st November 217

TABLE CUP

VARIATION FACTOR FOR COPPER CONDUCTOR (CUF)
POWER CABLES WITH COPPER CONDUCTOR

Nominal Cross Sectional Area (in Sq. mm.)	1 core	2 core	3 core	3.5 core	4 core
2.5	0.023	0.046	0.069	-	0.092
4	0.036	0.076	0.112	-	0.151
6	0.056	0.112	0.171	-	0.227
10	0.095	0.174	0.286	-	0.382
16	0.151	0.299	0.451	-	0.602
25/16	0.240	0.480	0.720	0.862	0.960
35/16	0.332	0.664	0.993	1.135	1.329
50/25	0.451	0.898	1.348	1.572	1.799
70/35	0.648	1.299	1.950	2.260	2.602
95/50	0.901	1.802	2.700	3.121	3.601
120/70	1.138	2.273	3.407	4.016	4.545
150/70	1.398	2.806	4.207	4.815	5.611
185/95	1.753	3.519	5.279	6.121	7.038
225/120	2.154	4.309	6.463	7.522	8.617
240/120	2.312	4.605	6.904	7.963	9.206
300/150	2.891	5.779	8.667	9.976	11.558
400/185	3.703	7.397	11.097	12.738	14.794
500	4.664	9.334	13.998	-	18.665
630	6.012	12.048	18.070	-	24.095
800	7.696	15.389	23.082	-	30.775
1000	9.706	19.372	29.055	-	38.741

TABLE CUscd

VARIATION FACTOR FOR COPPER CONDUCTOR (CUF)
1.0 & 1.5KV Solar PV DC Cables with Copper Conductor

Cable Size in sq.mm.	Copper content in MT/km
2.5	0.023
4	0.038
6	0.058
10	0.090

IEEMA (PVC)/CABLE(R-1)/2017

Effective from: 1st November 217

TABLE CUC

VARIATION FACTOR FOR COPPER CONDUCTOR (CUF)
CONTROL CABLES WITH COPPER CONDUCTOR

No of Cores	Core size 1.5 sq mm	Core size 2.5 sq mm
2	0.026	0.047
3	0.039	0.070
4	0.052	0.094
5	0.065	0.117
6	0.078	0.141
7	0.091	0.164
8	0.110	0.182
9	0.117	0.205
10	0.130	0.235
12	0.157	0.282
14	0.183	0.329
16	0.209	0.376
18	0.246	0.410
19	0.248	0.446
20	0.260	0.456
24	0.313	0.563
27	0.352	0.634
30	0.391	0.704
37	0.483	0.869
44	0.573	1.033
52	0.678	1.221
61	0.796	1.432

TABLE P1

VARIATION FACTOR FOR ALUMINIUM (AIF)
ALUMINIUM ARMoured SINGLE CORE PVC INSULATED 1.1 KV CABLES

Nominal cross sectional area (in Sq.mm)	Aluminium factor for Aluminium armoured cable with aluminium conductor
4	0.0685
6	0.0795
10	0.1017
16	0.1303
25	0.1693
35	0.2090
50	0.2597
70	0.3360
95	0.4567
120	0.5443
150	0.6427
185	0.7743
240	0.9737
300	1.2582
400	1.5502
500	1.8958
630	2.3650
800	2.9306
1000	3.7666

IEEMA (PVC)/CABLE(R-1)/2017

Effective from: 1st November 217

TABLE P2

VARIATION FACTOR FOR PVC COMPOUND (CCFAl/CCFCu)
PVC INSULATED 1.1 KV POWER CABLES WITH COPPER/ALUMINIUM CONDUCTOR

Nominal cross Sectional Area (in Sq. mm)	1 core		2 core		3 core		3.5 core		4 core	
	Unarm	arm	Unarm	arm	Unarm	arm	Unarm	arm	Unarm	arm
2.5	0.079		0.125	0.139	0.141	0.157	-	-	0.161	0.179
4	0.094		0.140	0.156	0.164	0.182	-	-	0.188	0.209
6	0.101		0.154	0.171	0.179	0.199	-	-	0.198	0.220
10	0.114		0.194	0.216	0.214	0.238	-	-	0.249	0.277
16	0.142		0.234	0.246	0.279	0.290	-	-	0.328	0.345
25	0.171		0.288	0.303	0.364	0.383	0.422	0.444	0.443	0.466
35	0.189		0.321	0.338	0.403	0.429	0.489	0.515	0.498	0.524
50	0.211		0.411	0.433	0.508	0.535	0.613	0.645	0.647	0.681
70	0.241		-	-	0.613	0.645	0.707	0.744	-	-
95	0.284		-	-	0.795	0.811	0.908	0.927	-	-
120	0.339		-	-	0.866	0.884	1.024	1.045	-	-
150	0.388		-	-	1.070	1.092	1.289	1.315	-	-
185	0.450		-	-	1.310	1.337	1.499	1.530	-	-
225	0.521		-	-	1.586	1.618	1.840	1.878	-	-
240	0.534		-	-	1.649	1.683	1.990	2.031	-	-
300	0.653		-	-	2.007	2.048	2.361	2.409	-	-
400	0.770		-	-	2.437	2.487	2.616	2.669	-	-
500	0.936		-	-	3.117	3.181	3.687	3.762	-	-
630	1.175		-	-	-	-	-	-	-	-
800	1.433		-	-	-	-	-	-	-	-
1000	1.642		-	-	-	-	-	-	-	-

IEEMA (PVC)/CABLE(R-1)/2017

Effective from: 1st November 217

TABLE P3

VARIATION FACTOR FOR STEEL (FeF)
PVC INSULATED 1.1 KV POWER CABLES WITH COPPER/ALUMINIUM CONDUCTOR

Nominal Cross sectional Area (in Sq. mm)	2 core	Shape	3 core	Shape	3 ½ core	Shape	4 core	Shape
4	0.305	W	0.335	W	-	-	0.363	W
6	0.348	W	0.363	W	-	-	0.407	W
10	0.392	W	0.407	W	-	-	0.293	F
16	0.235	F	0.293	F	-	-	0.323	F
25	0.293	F	0.352	F	0.382	F	0.382	F
35	0.323	F	0.382	F	0.411	F	0.440	F
50	0.382	F	0.440	F	0.469	F	0.499	F
70	0.411	F	0.499	F	-	F	0.587	F
95	0.499	F	0.587	F	0.616	F	0.645	F
120	0.528	F	0.616	F	0.675	F	0.731	F
150	0.587	F	0.675	F	0.731	F	0.790	F
185	0.645	F	0.761	F	0.820	F	0.879	F
240	0.731	F	0.879	F	0.937	F	0.996	F
300	0.820	F	0.966	F	1.055	F	1.113	F
400	0.937	F	1.083	F	1.172	F	1.231	F
500	1.055	F	1.231	F	1.348	F	1.406	F
630	1.172	F	-	-	-	-	-	-

IEEMA (PVC)/CABLE(R-1)/2017
TABLE P3 (Additional)

Effective from: 1st November 217

VARIATION FACTOR FOR ROUND WIRE 'W' STEEL (FeF)
PVC INSULATED 1.1 KV POWER CABLES WITH COPPER/ALUMINIUM CONDUCTOR

Nominal Cross Sectional Area (in sq. mm)	2 Core	3 Core	3.5 Core	4 Core
1.5	0.247	0.259		0.288
2.5	0.273	0.289		0.329
4	0.305	0.335		0.363
6	0.348	0.363		0.407
10	0.392	0.407		0.533
16	0.439	0.523	0.014	0.573
25	0.526	0.625	0.664	0.685
35	0.591	0.685	0.729	0.761
50	0.661	0.790	0.864	1.108
70	0.745	1.122	1.200	1.256
95	1.085	1.286	1.376	1.443
120	1.147	1.386	1.479	1.562
150	1.267	1.526	1.684	2.173
185	1.403	2.090	2.315	2.421
240	1.994	2.397	2.641	2.722
300	2.180	2.642	3.670	3.842
400	2.987	3.728	4.126	4.292
500	3.517	4.226	5.958	6.301
630	4.774	6.018	6.737	7.141

IEEMA (PVC)/CABLE(R-1)/2017

Effective from: 1st November 217

TABLE P4

VARIATION FACTOR FOR ALUMINIUM (AIF)
PVC INSULATED 1.1 KV POWER CABLES WITH COPPER CONDUCTOR

Nominal Cross Sectional Area (in Sq. mm)	Aluminium Factor for Aluminium armoured cable with copper conductor
4	0.058
6	0.063
10	0.073
16	0.084
25	0.096
35	0.108
50	0.123
70	0.139
95	0.183
120	0.198
150	0.218
185	0.241
240	0.271
300	0.379
400	0.424
500	0.478
630	0.537
800	0.591
1000	0.816

IEEMA (PVC)/CABLE(R-1)/2017

Effective from: 1st November 2017

TABLE P5

VARIATION FACTOR FOR PVC COMPOUND (CCFCu)
PVC INSULATED CONTROL CABLES WITH COPPER CONDUCTOR

No of cores	Core size 1.5 sq mm		Core size 2.5 sq mm	
	Unarm	Arm	Unarm	Arm
2	0.118	0.121	0.125	0.139
3	0.121	0.131	0.141	0.157
4	0.137	0.152	0.161	0.179
5	0.157	0.174	0.187	0.206
6	0.179	0.199	0.234	0.260
7	0.179	0.199	0.234	0.260
8	0.193	0.215	0.292	0.325
9	0.216	0.241	0.300	0.335
10	0.236	0.262	0.303	0.337
12	0.249	0.277	0.334	0.371
14	0.311	0.327	0.389	0.409
16	0.344	0.362	0.435	0.458
18	0.352	0.371	0.474	0.500
19	0.375	0.395	0.476	0.501
20	0.391	0.412	0.519	0.546
24	0.457	0.481	0.584	0.615
27	0.491	0.517	0.631	0.664
30	0.529	0.557	0.706	0.743
37	0.615	0.647	0.835	0.879
44	0.739	0.778	1.019	1.026
52	0.845	0.889	1.100	1.158
61	0.952	1.002	1.246	1.312

IEEMA (PVC)/CABLE(R-1)/2017
TABLE P6

Effective from: 1st November 2017

VARIATION FACTOR FOR STEEL (FeF)
PVC INSULATED CONTROL CABLES WITH COPPER CONDUCTOR

No of cores	Core size 1.5 sq mm	Shape of armour	Core size 2.5 sq mm	Shape of armour
2	0.243	W	0.277	W
3	0.257	W	0.289	W
4	0.277	W	0.314	W
5	0.303	W	0.342	W
6	0.329	W	0.379	W
7	0.329	W	0.379	W
8	0.341	W	0.456	W
9	0.383	W	0.275	F
10	0.408	W	0.325	F
12	0.289	F	0.342	F
14	0.306	F	0.360	F
16	0.317	F	0.372	F
18	0.332	F	0.350	F
19	0.343	F	0.397	F
20	0.368	F	0.400	F
24	0.398	F	0.475	F
27	0.414	F	0.478	F
30	0.425	F	0.503	F
37	0.461	F	0.548	F
44	0.507	F	0.601	F
52	0.556	F	0.641	F
61	0.585	F	0.685	F

IEEMA (PVC)/CABLE(R-1)/2017
TABLE P6 (Additional)

Effective from: 1st November 217

VARIATION FACTOR FOR ROUND WIRE 'W' STEEL (FeF)
PVC INSULATED CONTROL CABLES WITH COPPER CONDUCTOR

No. of Cores	Core size 1.5 sq mm	Core size 2.5 sq mm
2	0.243	0.273
3	0.257	0.289
4	0.277	0.314
5	0.303	0.342
6	0.329	0.379
7	0.329	0.379
8	0.341	0.456
9	0.383	0.508
10	0.408	0.535
12	0.510	0.572
14	0.546	0.625
16	0.581	0.660
19	0.608	0.696
24	0.714	0.819
25	0.679	0.798
27	0.732	0.837
28	0.696	0.815
30	0.758	0.881
33	0.747	0.883
37	0.820	1.217
44	0.926	1.355
48	1.122	1.308
50	1.122	1.308
52	1.149	1.361
56	1.202	1.388
61	1.299	1.520

IEEMA (PVC)/CABLE(R-1)/2017

Effective from: 1st November 217

TABLE L2

VARIATION FACTOR FOR POLYMER (CCFAI / CCFCu)
XLPE INSULATED 1.1 KV POWER CABLES WITH COPPER / ALUMINIUM CONDUCTOR

Nominal Cross Sectional Area (in Sq. mm)	1 core	2 core		3 core		3.5 core		4 core	
	Unarm	Unarm	Arm	Unarm	Arm	Unarm	Arm	Unarm	Arm
2.5	0.055	0.163	0.175	0.166	0.177	-	-	0.177	0.188
4	0.075	0.201	0.204	0.205	0.213	-	-	0.218	0.213
6	0.085	0.213	0.234	0.205	0.230	-	-	0.242	0.232
10	0.082	0.252	0.280	0.217	0.251	-	-	0.285	0.298
16	0.089	0.278	0.341	0.289	0.246	-	-	0.300	0.279
25	0.101	0.307	0.278	0.276	0.247	0.295	0.264	0.331	0.290
35	0.109	0.330	0.319	0.305	0.270	0.328	0.292	0.368	0.319
50	0.124	0.482	0.685	0.348	0.311	0.372	0.335	0.422	0.394
70	0.146	0.354	0.335	0.469	0.397	0.489	0.420	0.528	0.464
95	0.163	0.436	0.389	0.504	0.441	0.544	0.471	0.591	0.523
120	0.176	0.475	0.421	0.556	0.498	0.599	0.538	0.722	0.656
150	0.217	0.510	0.490	0.690	0.611	0.717	0.633	0.840	0.762
185	0.236	0.631	0.608	0.836	0.738	0.854	0.756	1.007	0.899
240	0.273	0.750	0.726	1.002	0.842	1.079	0.952	1.238	1.119
300	0.303	0.919	0.887	1.161	1.012	1.170	1.031	1.457	1.414
400	0.372	1.093	1.040	1.376	1.283	1.545	1.379	1.778	1.626
500	0.413	1.342	-	1.568	1.400	1.806	1.456	-	-
630	0.469	1.546	-	-	-	-	-	-	-
800	0.569	-	-	-	-	-	-	-	-
1000	0.667	-	-	-	-	-	-	-	-

IEEMA (PVC)/CABLE(R-1)/2017

Effective from: 1st November 217

TABLE XL1
VARIATION FACTOR FOR XLPE COMPOUND (XLFAL/XLFUCU)
XLPE INSULATED 1.1 KV POWER CABLES WITH COPPER/ALUMINIUM CONDUCTOR

Nominal cross Sectional Area (in Sq. mm)	1 core		2 core		3 core		3.5 core		4 core	
	Unarm	Arm	Unarm	Arm	Unarm	arm	Unarm	Arm	Unarm	arm
2.5	0.007	0.010	0.014	0.014	0.021	0.021			0.028	0.028
4	0.009	0.012	0.018	0.018	0.027	0.027			0.036	0.036
6	0.010	0.015	0.022	0.022	0.033	0.033			0.043	0.043
10	0.013	0.018	0.025	0.025	0.039	0.039			0.053	0.053
16	0.016	0.023	0.034	0.034	0.049	0.049			0.065	0.065
25	0.021	0.030	0.048	0.048	0.070	0.070	0.084	0.084	0.093	0.093
35	0.025	0.035	0.059	0.059	0.084	0.084	0.099	0.099	0.112	0.112
50	0.033	0.044	0.075	0.075	0.108	0.108	0.130	0.130	0.144	0.144
70	0.042	0.054	0.095	0.095	0.137	0.137	0.160	0.160	0.179	0.179
95	0.048	0.062	0.110	0.110	0.160	0.160	0.190	0.190	0.211	0.211
120	0.060	0.076	0.138	0.138	0.200	0.200	0.239	0.239	0.266	0.266
150	0.078	0.095	0.180	0.180	0.259	0.259	0.296	0.296	0.344	0.344
185	0.097	0.116	0.224	0.224	0.324	0.324	0.369	0.369	0.430	0.430
240	0.116	0.137	0.266	0.266	0.388	0.388	0.446	0.446	0.518	0.518
300	0.138	0.164	0.325	0.325	0.467	0.467	0.540	0.540	0.620	0.620
400	0.175	0.214	0.357	0.357	0.536	0.536	0.619	0.619	0.714	0.714
500	0.217	0.260	0.440	0.440	0.660	0.660	0.769	0.769	0.880	0.880
630	0.265	0.318	0.542	0.542	0.814	0.814	0.941	0.941	1.085	1.085
800	0.323	0.389								
1000	0.375	0.444								

TABLE XL2
VARIATION FACTOR FOR XLPE COMPOUND (XLFCU)
XLPE INSULATED CONTROL CABLES WITH COPPER CONDUCTOR

No of cores	Core size 1.5 sq mm		Core size 2.5 sq mm	
	Unarm	Arm	Unarm	Arm
2	0.010	0.010	0.012	0.012
3	0.016	0.016	0.018	0.018
4	0.021	0.021	0.025	0.025
5	0.026	0.026	0.031	0.031
6	0.031	0.031	0.037	0.037
7	0.036	0.036	0.043	0.043
8	0.036	0.036	0.043	0.043
9	0.042	0.042	0.049	0.049
10	0.052	0.052	0.061	0.061
12	0.062	0.062	0.074	0.074
14	0.073	0.073	0.086	0.086
16	0.083	0.083	0.098	0.098
18	0.094	0.094	0.110	0.110
19	0.099	0.099	0.116	0.116
20	0.104	0.104	0.123	0.123
24	0.125	0.125	0.147	0.147
27	0.140	0.140	0.165	0.165
30	0.156	0.156	0.184	0.184
37	0.192	0.192	0.227	0.227
44	0.229	0.229	0.270	0.270
52	0.270	0.270	0.319	0.319
61	0.317	0.317	0.374	0.374

IEEMA (PVC)/CABLE(R-1)/2017

Effective from: 1st November 217

TABLE XL3

VARIATION FACTOR FOR XLPE(XLFAL/XLFCU)

SINGLE CORE ARMoured /UNARMoured XLPE INSULATED 3.3 to 33 KV POWER CABLES WITH
CU / AL CONDUCTOR

Nominal Cross Sectional Area (in Sq. mm.)	XLPE Factor for Armoured/ Unarmoured Cable with AL /CU Conductor					
	3.3 KV	6.6 KV (E)	11 KV (E)/ 6.6 KV (UE)	11 KV (UE)	22 KV (E)	33 KV (E)
25	0.110	0.131	0.170	0.279		
35	0.122	0.137	0.175	0.284	0.317	0.522
50	0.135	0.151	0.191	0.307	0.341	0.563
70	0.155	0.172	0.215	0.342	0.379	0.615
95	0.174	0.193	0.241	0.377	0.417	0.670
120	0.192	0.212	0.262	0.407	0.449	0.713
150	0.209	0.229	0.283	0.437	0.481	0.757
185	0.228	0.250	0.308	0.471	0.518	0.809
240	0.255	0.279	0.343	0.519	0.569	0.883
300	0.280	0.322	0.372	0.560	0.613	0.943
400	0.326	0.392	0.420	0.625	0.683	1.041
500	0.388	0.461	0.469	0.694	0.757	1.142
630	0.467	0.520	0.529	0.777	0.845	1.265
800	0.567	0.593	0.602	0.874	0.949	1.407
1000	0.656	0.665	0.660	0.955	1.036	1.525

Note : XLPE factors include Semicons for Conductor & Insulation screen

TABLE - XL4

VARIATION FACTOR FOR XLPE (CCF1A/ / CCF1Cu)

3 CORE XLPE INSULATED 3.3 to 33 KV POWER CABLES WITH COPPER / ALUMINIUM CONDUCTOR

Nominal Cross Sectional Area (in Sq. mm)	3.3 KV ARM	6.6 KV (E) ARM	6.6 KV (UE) / 11 KV (E) ARM	11 KV (UE) ARM	22 KV (E) ARM	33 KV (E) ARM
25	0.315	0.394	0.511	0.838		
35	0.339	0.427	0.545	0.880	0.982	1.638
50	0.378	0.474	0.600	0.957	1.065	1.751
70	0.435	0.541	0.679	1.067	1.183	1.916
95	0.489	0.604	0.755	1.171	1.295	2.071
120	0.537	0.661	0.822	1.265	1.396	2.210
150	0.585	0.719	0.890	1.359	1.497	2.350
185	0.642	0.784	0.968	1.468	1.614	2.513
240	0.717	0.873	1.074	1.615	1.773	2.732
300	0.781	1.006	1.167	1.744	1.928	2.919
400	0.886	1.227	1.314	1.948	2.130	3.229
500	0.956	1.421	1.446	2.148	2.381	3.538
630	1.129	1.582	1.609	2.382	2.630	3.940

Note : XLPE factors include Semicons for Conductor & Insulation screen

TABLE H1
VARIATION FACTOR FOR ALUMINIUM (AIF)
ALUMINIUM ARMoured SINGLE CORE XLPE INSULATED 3.3 TO 33 KV CABLES

Nominal Cross Sectional Area (in Sq. mm.)	Aluminium Factor for Aluminium Armoured Cable with Aluminium Conductor					
	3.3 KV	6.6 KV (E)	11 KV (E)/ 6.6 KV (UE)	11 KV (UE)	22 KV (E)	33 KV (E)
35	0.251	0.284	0.301	0.344	0.358	0.473
50	0.312	0.336	0.352	0.397	0.408	0.672
70	0.385	0.409	0.423	0.469	0.501	0.723
95	0.476	0.500	0.518	0.637	0.656	0.856
120	0.561	0.586	0.601	0.726	0.744	0.949
150	0.653	0.678	0.696	0.823	0.842	1.050
185	0.773	0.797	0.893	0.949	0.965	1.183
240	0.997	1.063	1.083	1.139	1.154	1.387
300	1.209	1.271	1.283	1.333	1.307	1.753
400	1.438	1.556	1.565	1.620	1.636	2.046
500	1.873	1.901	1.910	2.110	2.128	2.484
630	2.337	2.361	2.369	2.580	2.595	2.978
800	3.007	3.071	3.080	3.145	3.163	3.588
1000	3.737	3.741	3.749	3.804	3.822	4.565

TABLE H2
VARIATION FACTOR FOR POLYMER (CCFAI / CCFcu)
3 CORE XLPE INSULATED 3.3 to 33 KV POWER CABLES WITH COPPER / ALUMINIUM CONDUCTOR

Nominal Cross Sectional Area (in Sq. mm)	3.3 KV ARM	6.6 KV (E) ARM	6.6 KV (UE) / 11 KV (E) ARM	11 KV (UE) ARM	22 KV (E) ARM	33 KV (E) ARM
35	0.374	0.990	1.142	1.604	1.782	-
50	0.445	1.119	1.260	1.834	2.046	2.864
70	0.547	1.290	1.396	2.011	2.284	3.219
95	0.594	1.440	1.647	2.269	2.428	3.367
120	0.732	1.692	1.877	2.498	2.715	3.646
150	0.812	1.906	2.061	2.767	2.931	3.927
185	0.960	2.086	2.406	3.028	3.180	4.166
240	1.130	2.484	2.744	3.398	3.580	4.589
300	1.219	2.912	3.161	3.840	4.016	5.029
400	1.313	3.530	3.664	4.353	4.666	5.736
500	1.652	3.925	3.971	4.621	4.878	5.913
630	1.949	4.487	4.982	5.225	5.477	6.696

Fillers added in PVC consumption

IEEMA (PVC)/CABLE(R-1)/2017

Effective from: 1st November 217

TABLE H3
VARIATION FACTOR FOR STEEL (FeF)
XLPE INSULATED 3.3 TO 33 KV POWER CABLES WITH COPPER / ALUMINIUM CONDUCTOR

Nominal Cross Sectional Area Sq. mm.	3.3 KV	6.6 KV (E)	11 KV (E) / 6.6 KV (UE)	11 KV (UE)	22 KV (E)	33 KV (E)
25	0.551	0.604	0.656	0.814		
35	0.645	0.645	0.731	0.879	0.937	-
50	0.675	0.703	0.761	0.937	0.966	1.181
70	0.761	0.761	0.849	0.996	1.055	1.289
95	0.820	0.849	0.907	1.083	1.113	1.348
120	0.879	0.907	0.966	1.142	1.172	1.406
150	0.966	0.966	1.055	1.201	1.259	1.494
185	1.025	1.055	1.113	1.259	1.318	1.553
240	1.142	1.142	1.231	1.377	1.406	1.641
300	1.231	1.259	1.318	1.465	1.524	1.758
400	1.348	1.406	1.435	1.582	1.641	1.876

TABLE H4
VARIATION FACTOR FOR ALUMINIUM (AIF)
XLPE INSULATED SINGLE CORE 3.3 TO 33 KV POWER CABLES WITH COPPER CONDUCTOR

Nominal Cross Sectional Area (in Sq. mm.)	Aluminium Factor for Aluminium Armoured Cable with Copper Conductor					
	3.3 KV	6.6 KV (E)	11 KV (E)/ 6.6 KV (UE)	11 KV (UE)	22 KV (E)	33 KV (E)
35	0.153	0.187	0.204	0.247	0.258	0.372
50	0.179	0.203	0.220	0.262	0.275	0.425
70	0.196	0.219	0.233	0.278	0.311	0.444
95	0.213	0.237	0.254	0.373	0.392	0.470
120	0.228	0.253	0.268	0.393	0.410	0.488
150	0.243	0.269	0.287	0.414	0.432	0.504
185	0.261	0.285	0.381	0.437	0.455	0.526
240	0.324	0.389	0.410	0.465	0.480	0.556
300	0.365	0.428	0.440	0.490	0.510	0.737
400	0.432	0.471	0.480	0.536	0.552	0.783
500	0.489	0.517	0.526	0.726	0.744	0.844
630	0.544	0.568	0.572	0.787	0.801	0.902
800	0.706	0.787	0.797	0.862	0.880	0.982
1000	0.824	0.865	0.867	0.923	0.940	1.324

TABLE - H5
VARIATION FACTOR FOR STEEL (FeW)
XLPE INSULATED 3.3KV TO 33 KV POWER CABLES WITH COPPER / ALUMINIUM CONDUCTOR

Nominal Cross Sectional Area in Sq. mm	3.3/3.3 KV	3.3/6.6 KV	11 KV (E) / 6.6 KV (UE)	11 KV (UE)	22 KV (E)	33 KV (E)
25	1.258	1.457	1.612	2.509	1.503	--
35	1.361	1.569	1.853	2.644	2.797	2.517
50	1.682	1.687	2.321	2.800	2.921	4.569
70	2.033	1.979	2.503	3.219	3.347	4.809
95	2.202	2.507	2.718	4.019	4.200	5.437
120	2.371	2.675	2.882	4.241	4.416	6.713
150	2.870	2.847	3.265	4.447	4.621	6.976
185	3.121	3.309	4.148	4.726	5.289	7.356
240	3.758	4.227	4.442	5.442	6.651	7.718
300	4.099	5.024	5.182	6.894	7.084	8.187
400	5.750	6.572	6.658	7.433	7.657	8.760
500	6.716	6.777	6.861	7.588	7.797	8.830
630	7.492	7.465	7.477	8.209	8.386	9.413