

Bharat Heavy Electricals Limited, Tiruchirappalli 620014
MATERIALS MANAGEMENT

Phone: 0431 – 257 7362; www.bhel.com

NOTICE INVITING e-TENDER

Dear Sir/ Ma'am,

Kindly submit your competitive offer for **ERV Controller Box for RH application** as per the tender terms and conditions given in the tender document through NIC e-procurement portal only.

This two-part e-tender consists of the following:

- 1. Annexure A - Pre-Qualification Requirement, Techno - commercial terms and conditions**
- 2. Technical Specification**
- 3. BHEL Standard quality plan**
- 4. Checklist and Annexures**

General Instructions

- The tender documents shall be deemed to form an integral part of the purchase order.
- Tender can be cancelled at any stage due to unavoidable circumstances.
- Bidders are advised not to wait till the last minutes w.r.t tender closing time to submit their offer to avoid complications related with internet connectivity / network problem/ power failure etc.
- Bidders are advised take due care while quoting the technical and price bids forms in the e-procurement system. Bidders, those who tampers with tendering procedure affecting ordering process or misusing the technical information of the tender document or withdrawing their offer after price bid opening, will be penalized as per BHEL guidelines on suspension of business dealings with suppliers/ contractors. Abridged version of the guideline is available in www.bhel.com.
- Bidders who have been suspended or black listed or issued with "Show Cause Notice" by BHEL, Tiruchirappalli -620014 or any other unit or GOI will not be allowed to participate in the tender and bidder should declare the same in the tender. Even during the course of evaluation/ finalization of tender, if it is found that some of the parties are black listed/ barred from business transaction/ under business hold, BHEL will not consider them for further participation in the tender.
- It is advised that all the documents to be submitted are kept scanned or converted to PDF format in a separate folder on your computer before starting online submission.
- In case you are not in a position to submit the offer, please send letter suitably specifying the reasons thereof.
- **For supply orders placed on Indian Suppliers: Irrespective of the value of the invoice amount, the bidder / vendor should necessarily upload the despatch & invoice details on BHEL SUVIDHA portal at <https://suvridha.bhel.in/suvridha/>, prior to despatch. All documents as per PO checklist , along with additional documents (if any), must be uploaded on the portal. It is mandatory that tax invoices with a net amount (including taxes) exceeding Rs Five lakhs uploaded on the portal are digitally signed using a Class 3 Digital Signature Certificate (DSC) issued by a licensed Certifying Authority. Submission of invoice document in hard copy is allowed for invoices with a net amount (including taxes) equal to and upto Rs Five lakhs , in case they were not digitally signed and uploaded on the portal. The material will not be accepted inside BHEL in absence of the above.**
- **DISCLAIMER CLAUSE:** Neither the Organization (Bharat Heavy Electricals Ltd.) nor the NIC is responsible for any failure of submission of bids due to failure of internet or other connectivity problems or reasons thereof.

Thanking you,
For **Bharat Heavy Electricals Limited**

Fousiya EK
Engineer / Materials Management
24 Building, B.H.E.L., Tiruchirappalli – 620 014, Tamilnadu
Phone: 0431-2577362
Email: fousiya@bhel.in



**CONTROLS & INSTRUMENTATION (FB)
PRE-QUALIFICATION REQUIREMENT (PQR)**

CI:PE: PQR: CTRL BOXES
Rev. No: 02
Dt. : 15-07-23

MOTOR STARTER BOXES & ELECTRIC CONTROL BOXES

| Sl. No. | Description | Bid requirements | Bidder Compliance | Documents to be submitted by bidder for PQR validation |
|----------------|---------------------|--|--------------------------|---|
| (A) | (B) | (C) | (D) | (E) |
| 1. | Proven Track record | Vendor should have already executed Purchase orders of Electrical items like Electrical Control panels or Motor Starter boxes, prior to the date of Techno-Commercial bid opening. | Yes/No | PO copy with respective GA & wiring drawing, Respective invoice / Dispatch clearance from the end user of earlier executed order. |
| 2. | Testing Facilities | Bidder shall have the facility to conduct the testing of Motor starter boxes or Control panels as per the enquiry. | Yes/No | List of testing facilities |

General Notes:

1. On meeting the Bid requirements, Bidder to provide their compliance for each point in the Bidder compliance column (D).
2. Vendor shall submit, sealed & signed copy of the documents, as requested in column (E) . Before submission, Bidder to ensure the correctness of the documents. If any discrepancy is noted, the offer is liable for rejection.

Bidder Sign & Seal:

TECHNICAL CATALOGUE

| | |
|-------------------------------|--|
| Material Code : | R61172500003 |
| Item Description : | ERV CONTROLLER BOX FOR RH APPLICATON |
| Detailed Description : | <p>1) Electromatic Relief Valve (ERV) controller Unit, pressure switch and accessories, for Re-Heater application as per the technical specification TDC: TCI:250, Rev. 00.</p> <p>2) Material of construction of sheet steel shall be as per standard EIN 10130 JIS G3141</p> <p>3) The exterior paint shade shall be RAL7035 and the interior paint shade shall be Brilliant White.</p> <p>4) Rated voltage of the system shall be 220V DC.</p> <p>5) Vendor to select the pressure switch model based on the following values. Set Points - 67.1 KG/SQCM (OPEN), 65.1 KG/SQCM (CLOSE) and 3% blow down). Calibration test certificates and Tag plates shall be supplied along with the pressure switches.</p> <p>6) Inspection <(>&<)> Testing shall be as per the Quality Plan Ref.: QA:CI:STD:QP:60, Rev. 02</p> <p>7) Make of accessories shall be as per the Quality Plan Ref.: QA:CI:STD:QP:34, Rev. 04</p> <p>8) Packing Procedure Ref.: QA:CI:STD:PR:02 Rev. 03</p> <p>9) Suitable cable glands for termination of external cables shall be provided</p> <p>10) Following details shall be inscribed on the name plate of ERV controller box. VALVE TAG NO : LBB11AA702 <(>&<)> LBB12AA702 (SET PRESSURE 67.1 KG/SQCM (OPEN), 65.1 KG/SQCM (CLOSE) and 3% bLOW DOWN)</p> |

Bharat Heavy Electricals Limited

High Pressure Boiler Plant, Tiruchirappalli-620 014.

TECHNICAL DELIVERY CONDITIONS
FOR SUB - DELIVERY COMPONENTS OF
CONTROLS AND INSTRUMENTATION

Specification No. TCI: 250

Page 01 of 05

Technical specification

Of

ELECTRO MATIC RELIEF VALVE (ERV) CONTROL UNIT & PRESSURE SWITCH

| Rev. No. | Date | Description | Prepared & Reviewed | Approved |
|----------|------------|-----------------|---------------------|--------------------|
| 00 | 07-04-2021 | Initial Release | <i>Moorthy Paul</i> | <i>[Signature]</i> |

| Sl. No | Technical Description/ Requirement | |
|--------|--|---|
| 1. | General | This technical specification covers the requirements of the Electro - Matic relief valve Controller box, for Super Heater/ Re Heater Steam relief applications of thermal power boilers. |
| 2. | SITE CONDITIONS: - Altitude above Sea Level Atmosphere Relative humidity Operating temperature | 500 Meters Tropical, Dusty, Windy & Heavily polluted atmosphere 100 % 50 degree Celsius |
| 3. | Input Documents to be followed | <ul style="list-style-type: none"> • Operational Logic & Wiring Drawing: As per the drawing 3-97-577-09565, Rev. 04 • General Arrangement as per the drawing 3-97-577-09562, Rev. 07 • Name Plate & Instruction Plate details: As per the drawing 4-97-577-10225, Rev. 02 & 4-97-577-10226, Rev. 03 |
| 4. | Construction Details | <ul style="list-style-type: none"> • ERV Controller Box - Material of construction: CRCA Sheet Steel, Grade D as per IS513 of thickness - 2 mm. • Component Mounting plate and Cable gland plate – Material of Construction: Galvanized, CRCA Sheet Steel, Grade D of thickness – 3 mm, Galvanization thickness - 15 to 25 microns. • The mounting plate shall be mounted on the studs (4 nos.). The studs shall be welded in the inside of the box. • Suitable Slot shall be provided in the cable gland plate matching the pressure switch dimensions for tight fit. • Neoprene Gasket of thickness 3 mm shall be provided for the Gland plate and Door. |
| 5. | Enclosure protection | Protection Class : IP 65 |
| 6. | Electrical and Pneumatic Entries | 3 nos. of 3/4" hole for the entry of cables and 1 no. of slot suitable for the impulse line of pressure switch shall be provided in the Gland plate. Dummy plugs shall be provided on the holes to avoid water entry. |





| Sl. No | Technical Description/ Requirement | |
|--------|------------------------------------|--|
| 7. | Door & Locking Arrangement | <ul style="list-style-type: none"> • Continuous Hinged Door suitable for 180° opening shall be fitted on left side of the box. Door shall also be earthed by using flexible Copper Braid. • Rider Clamp arrangement shall be provided for locking. • Padlocking arrangement with 1 no. lock and 3 nos. key shall be provided. |
| 8. | BOM & Accessories | <p>All the accessories shall be rated for either 220 V DC or 110 V DC, as per the voltage (project specific) indicated in the purchase enquiry. Following are the BOM to be followed.</p> <ol style="list-style-type: none"> 1) Dual Set point, Bourdon tube pressure switch of electrical rating 0.25 A, 220 V DC. Pressure switch model shall be selected, as per the Open & Close set points, Maximum operating pressure furnished in the enquiry. Test/ Calibration certificates and tag plates shall be supplied. Make: M/s. Barksdale, GmbH. Set point shall be indicated on the pressure switch in kg/ cm². 2) 2 pole, DC Coil, Contactor of current rating 32 A (Make SIEMENS, Model: 3TC-44-170A or equivalent model from any of the makes as indicated in QA:CI: STD: QP:34). 2 nos. of power contacts, 2 NO + 2 NC Auxiliary Contacts shall be provided. 3) 1 No. of Red colored, LED type indicating lamp. 4) Terminal blocks suitable for current rating 32 A. 5) 2 nos. of Metal Oxide Varistor. <p>For items 3 and 4, any of the Makes as indicated in the document QA:CI: STD: QP: 34 shall be followed.</p> |
| 9. | Mounting & Earthing | <ul style="list-style-type: none"> • The box shall be provided with 4 Nos. of Mounting brackets with 50 mm wide, 6 mm thick plates. Galvanized Mounting bolts (M10 x 40 mm), Spring washers and Nuts shall be supplied. • Earthing Bolts – MS with Chromium plate (Plating thickness – 10 to 15 microns). |

| Sl. No | Technical Description/ Requirement | |
|--------|--|--|
| 10. | Wiring & Ferruling | <ul style="list-style-type: none"> • All internal wiring shall be done by using 2.5 Sq. mm. stranded, single core copper PVC insulated wire. • Suitable type crimping lugs, shall be used for wiring. • Yellow ferrule with black lettering shall be used Over the insulation for wire identification. |
| 11. | Painting | <ul style="list-style-type: none"> • Powder coating shall be done for both exterior and interior surface of the controller box. Paint shade will be furnished in the enquiry. • Exterior: Semi-glossy finish, minimum thickness - 60-70 microns. • Interior: Glossy finish, minimum thickness - 50 – 60 microns. |
| 12. | Nameplate & Instruction Plate Drawings | <ul style="list-style-type: none"> • Name plate as per the drawing 4-97-577-10225, Rev. 02 shall be provided at the front side of the box. • Instruction Plate as per the drawing 4-97-577- 10226, Rev. 03 shall be fixed at the backside of the door. |
| 13. | Wiring | All the electrical accessories and the pressure switch shall be wired in the ERV control box as per the wiring drawing. |
| 14. | Inspection & Testing | <ol style="list-style-type: none"> a) Inspection and testing of the ERV controller box will be as per the quality plan QA:CI: STD: QP:60 (latest revision). b) For each pressure switch, vendor has to submit the Calibration test certificates from the OEM for BHEL's verification. |
| 15. | Packing procedure | Packing procedure QA:CI: STD:PR:02 (Latest Revision) shall be followed. |
| 16. | Documents to be submitted during the offer | <ol style="list-style-type: none"> a) The Sub-Delivery Enquiry Deviation format shall be filled in with the details of BHEL's enquiry number, project name, technical specification of the ERV, Quality plan & Packing procedure. b) Conforming to all the requirements, vendor to indicate "No deviation" in the sub-delivery enquiry deviation format. |

| Sl. No | Technical Description/ Requirement | |
|--------|--|--|
| | | c) Vendor to note that Any deviation/ clarification/ alternate offer to the BHEL's enquiry requirements, shall only be indicated in the Sub-Delivery Enquiry Deviation form. Deviations indicated elsewhere in the offer will not be considered. |
| 17. | Documents to be submitted on placement of purchase order | a) General arrangement drawing, wiring drawing, terminal block drawing. b) Bill of material with make, model no., rating and quantity of components. c) Operation & Maintenance manuals containing the catalogues of various accessories. |

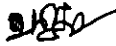
**BHARAT HEAVY ELECTRICALS LIMITED / TIRUCHIRAPPALLI
CONTROLS AND INSTRUMENTATION/QA/FB**

**STANDARD QUALITY PLAN
FOR
ELECTRICAL PANEL ACCESSORIES**

| REV | DATE | PREPARED | REVIEWED | APPROVED | | REVISION HISTORY |
|-----|----------|--|---|--|--|---|
| | | | | ENGG. | QUALITY | |
| 00 | 16.06.97 | -Sd- | -Sd- | -Sd- | -Sd- | Initial release |
| 01 | 22.02.99 | -Sd- | -Sd- | -Sd- | -Sd- | New Vendors Added |
| 02 | 21.03.02 | -Sd- | -Sd- | -Sd- | -Sd- | Dept. name changed & General revision-Based on Engg. discussion. |
| 03 | 08.01.04 | -Sd- | -Sd- | -Sd- | -Sd- | Revised to include the comments /Feedback of internal discussion |
| 04 | 07.12.07 | RM.VAIRAVAN  | N.SRIDHAR  | L.A.E.Fernandez  | S.SOMASUNDARAM  | Vendor list updated. Inputs considered are: <ul style="list-style-type: none"> • TCE approved List for Jojobera • NTPC approved list for BAP(Sipat). • NTPC approved list for Korba-III. • NTPC approved list for Barh STPP. • Feedbacks obtained during discussion |

| SL.NO | PRODUCT | APPROVED VENDORS |
|-------|--------------------------------------|--|
| 01 | Air Circuit Breaker. | L&T / GEPC / SIEMENS / CONTROLS & SWITCHGEAR Co.LTD / SCHNEIDER-MERLIN GERIN ENERPACT |
| 02 | Miniature circuit breaker (MCB). | MDS / CROMPTON GREAVES / INDO - ASIAN / IM / LUPUS / SCHNEIDER ELECTRIC / SIEMENS / L&T – HAGER /INDOKOPP/COOPER BUSMANN /STANDARD |
| 03 | Moulded case circuit breaker (MCCB). | L&T / GEPC./ CROMPTON GREAVES / BCH / ABB / SIEMENS / CONTROLS & SWITCHGEAR Co.LTD/ SCHNEIDER ELECTRIC / ANDREW YULE /AREVA |
| 04 | Power contactors – AC. | L&T / SIEMENS / CONTROLS & SWITCHGEAR CONTACTORS LTD (TC) / SPRECHER & SCHUH / ANDREW YULE / BCH / GEPC / CROMPTON GREAVES / SCHNEIDER ELECTRIC |
| 05 | Power & Auxiliary Contactors – DC. | GEPC / BCH / CONTROLS & SWITCHGEAR CONTACTORS LTD(TC) / SIEMENS / SPRECHER & SCHUH / L&T / SCHNEIDER ELECTRIC/ANDREW YULE. |
| 06 | Auxiliary Contactors – AC. | L&T / SIEMENS / ABB / BCH / CONTROLS & SWITCHGEAR CONTACTORS LTD(TC) / CROMPTON GREAVES / GEPC/ SPRECHUR & SCHUH / SCHNEIDER ELECTRIC / ANDREW YULE. |
| 07 | Indicating lamp. | SIEMENS / VAISHNAO / GEPC / BCH / L&T - ESBEE / CANDS / TEKNIC / CONCORD / ESSEN / CONTROLS & SWITCHGEAR CONTACTORS LTD(TC)-RASS Series |
| 08 | Push Button. | SIEMENS / BCH / TEKNIC / CANDS / L&T - ESBEE / VAISHNAO / GEPC / CONTROLS & SWITCHGEAR CONTACTORS LTD(TC)-RASS Series / SCHNEIDER ELECTRIC/CONCORD. |
| 09 | Illuminated Push button | PARAMOUNT / BCH |
| 10 | Indicating Instruments. | AE / IMP / MECO / L&T-RISHAB / SIETEX / MASSIBUS/ALSTOM. |
| 11 | Switches (Power / Control). | KAYCEE / SIEMENS / L&T / SALZAR/ GEPC / CONTROLS & SWITCHGEAR Co. LTD / SCHNEIDER ELECTRIC / SWITRON (For Control switch only) |

| SL.NO | PRODUCT | APPROVED VENDORS |
|-------|---|---|
| 12 | Thermal Overload Relays. | L&T / SIEMENS / CONTROLS & SWITCHGEAR CONTACTORS LTD (TC) / BCH / GEPC / SPRECHER & SCHUH / CROMPTON GREAVES / SCHNEIDER ELECTRIC/ ANDREW YULE. |
| 13 | Protective Relays(Electromechanical). | AREVA / EASUN REYROLLE / ABB / SEG & CONTROLS / SIEMENS. |
| 14 | Protective Relays(Microprocessor). | AREVA / ABB / L&T |
| 14 | Timers - Electronic. | SIEMENS / ABB / CONTROLS & SWITCHGEAR CONTACTORS LTD((TC) / GEPC / OMRON / SPRECHER & SCHUH / SELECTRON. / BCH |
| 15 | Timers - Electro – Pneumatic. | BCH / CONTROLS & SWITCHGEAR CONTACTORS LTD(TC)/ SPRECHER & SCHUH |
| 16 | Timers - Synchronous. | L&T - G I C. |
| 17 | Annunciators. | IIC / L&T / PROCON / ADVANI OERLIKON / OMRON / PIRI / PECON / SIEMENS/MINILEC |
| 18 | Current & Potential transformers. | AE / KAPPA / INDCOIL / PRAYOG / CONTROLS & SWITCHGEAR CONTACTORS LTD(TC) / SIEMENS / APPOLO / PRAGATI / PRECISE / JYOTI / SILKAANS/G&M(For PT only) . |
| 19 | Control supply transformers. | AE / KAPPA / INDCOIL / SOUTHERN ELECTRIC / SIEMENS / APPOLO / CONTROLS & SWITCHGEAR / PRECISE / LOGICSTAT/PRAGATI/PRAYOG |
| 20 | Terminal block - screw type (terminals & fasteners shall be brass with nickel cadmium plated). | ESSEN / ELMEX (THERMO –PLASTIC TYPE) / TOSHA / ASIA ELECTRIC (IEC MAKE) / CONNECT WELL / TECHNOPLAST / VEECON / PHOENIX/WAGO |
| 21 | Terminal Block – Cage Clamp type. | WAGO / PHOENIX / ELMEX |
| 22 | Fuse Carriers. | SIEMENS / L&T / S&S / CROMPTON GREAVES / CONTROLS & SWITCHGEAR Co. LTD / GEPC / COOPER BUSSMAN. |
| 23 | Fuse Links/Neutral Links. | SIEMENS / L&T / CROMPTON GREAVES / CONTROLS & SWITCHGEAR Co.LTD/ GEPC / CANDS / COOPER BUSSMAN. |

| SL.NO | PRODUCT | APPROVED VENDORS |
|-------|---|--|
| 24 | Panel Wires | BIS APPROVED |
| 25 | Cable Glands – (weather proof). | COMET / POWER ENGG / SUNIL & CO / SMI / BRACCO / ARUP ENGG. WORKS / QPIE / GLANDMECH / CONTROLS & SWITCHGEAR Co. LTD / QUALITY PRECISION |
| 26 | Ferrules | MICROSIGN/MAY FAIR/OESER |
| 27 | Lugs. | DOWELL / 3D / DIVYA JYOTHI / CHETNA / JAINSONS |
| 28 | Space Heater. | SOPHIA / CANDS / CROMPTON GREAVES / PYRO SYSTEM / VELCO / CONTROLS & SWITCHGEAR Co.LTD. |
| 29 | 15/5 A Power Supply Switch With Plug & Socket (Metal Clad Type With Spring Loaded Cap). | CROMPTON GREAVES/ AJMERA / BCH / BEST & CROMPTON./GEWIS INDIA |
| 30 | Cubicle Illumination Lamp. | PHILIPS / BAJAJ / CROMPTON GREAVES / MYSORE LAMPS / HMT. |
| 31 | Door Switch. | ESSEN / IEC. |
| 32 | Cooling Fan. | RALLI-WOLF / KHAITAN / USHA. |
| 33 | Interposing Relay (Low Burden). | JYOTHI / OMRON / ABIL / ABB / SIEMENS / GEPC / OEN / L&T/OWN MAKES OF APPROVED PLC VENDORS. |
| 34 | Cable Glands - Flame Proof. | BALIGA / SUDHIR / CEAG / PROMPT / COMET |
| 35 | Indicating Lamp – LED. | SRISHYLA / TEKNIC / PARAMOUNT / BINAY / KWALITY / HEWLETT PACKARD |
| 36 | Motor Protection Circuit Breaker | L&T / GEPC / SIEMENS / SCHNEIDER ELELCTRIC / SPRECHER & SCHUH . |
| 37 | Cable Dressing Material. | MICROSIGN. |
| 38 | Wire Duct. | SALZAR. |

| SL.NO | PRODUCT | APPROVED VENDORS |
|-------|-----------------------|--|
| 39 | Electrical Transducer | ABB / AE / SOUTHERN TRANSDUCER/ELSTER/RISHAB. |
| 40 | Thermostat | APT / TEMPTROL / VIKAS ELECTRIC / AI / RENUTROL / ANCO |
| 41` | Trivector Meter | ALSTOM / BHEL/AREVA/IMP |



CONTROLS AND INSTRUMENTATION/QA/FB

STANDARD QUALITY PLAN FOR

ERV CONTROLLER BOX

| REV | DATE | PREPARED | REVIEWED | | APPROVED | REVISION HISTORY |
|-----|------------|------------------------------|--------------|-----------------------|----------------|---|
| 00 | 10/02/2004 | Sd/- | Sd/- | | Sd/- | Initial release. |
| 01 | 23/06/2009 | RM.VAIRAVAN | N.SRIDHAR | | S.SOMASUNDARAM | QP revised to modify with the practice followed in NTPC projects and inspection feedback. |
| 02 | 01.08.2011 | B ARUNKUMAR B. Arunkumar. | K BALAJI | G V CHILAMBARASAN | D KAVITHA | Reference standards revised. Notes 6 modified |



| Sl. No | Component & Operation | Characteristics | Class | Type of Check | Quantum of check | | Ref Doc. & Acceptance STD | Format of record | AGENCY | | | REMARKS |
|-----------|------------------------------------|--|-------|---------------|------------------|---------------|---------------------------|------------------|--------|---|---|---------------------------------------|
| | | | | | M | B/C | | | M | B | C | |
| A | FINISHED PRODUCT INSPECTION | | | | | | | | | | | |
| 01 | Routine tests | a. Visual (Name plate Details) | PHYS | Major | 100% | 30% | PO Spec. | TR | P | W | - | |
| | | b. Dimension, including sheet steel thickness | MEAS | Major | 100% | 30% | PO Spec, Drg. | TR | P | W | - | |
| | | c. Painting: Shade, thickness, finish | VISU | Major | 100% | 30% | PO Spec, Drg. | TR | P | W | - | |
| | | d. Make, rating of components mounted. | PHYS | Major | 100% | 30% | PO Spec, Drg. | TR | P | W | - | |
| | | e. Wiring: Ferruling & crimping | ELEC | Major | 100% | 30% | PO Spec, Drg. | TR | P | W | - | |
| | | f. Availability of pressure switch, type and number of contacts | PHYS | Major | 100% | 30% | PO Spec, Drg. | TR | P | W | - | |
| | | g. Functional check for pressure switch actuation for both increasing and decreasing pressure settings | ELEC | Critical | 100% | 100% | PO Spec, Drg. | TR | P | V | - | Verification of TC of pressure switch |
| | | h. Insulation resistance test both before and after HV test | ELEC | Major | 100% | 100% | PO Spec, Drg. | TR | P | W | - | |
| | | i. High voltage test for wiring at 1.5KV for 1 minute | ELEC | Major | 100% | 100% | PO Spec, Drg. | TR | P | W | - | |
| | | j. Verification of accessories as per PO | PHYS | Major | 100% | 30% | PO Spec, Drg. | TR | P | W | - | |
| 02 | Type test | a. Enclosure Protection test for box | Major | ENVI | One of sample | One of sample | PO Spec. IS/IEC 60529 | TC | V | V | - | |



B.NOTES:

1.LEGENDS:

| | | | | | |
|------|---|-------------|------|---|------------------|
| MECH | : | Mechanical | MEAS | : | Measurement |
| ELEC | : | Electrical | ENVI | : | Environmental |
| TR | : | Test Report | TC | : | Test certificate |
| VISU | : | Visual | | | |

- The vendor shall arrange all testing facilities at their works. Tests for which facilities are not available are to be carried out at recognized National Test Houses like ETDC/CIL/NPL/ERTL etc., at vendor cost.
- Through Log Book / any other documents available at the vendor's works, it shall be possible to correlate the finished products with raw material and in process stage checks / inspection carried out.
- All Measuring and Testing Instruments shall be periodically calibrated from recognized test houses & certificates made available during inspection for verification.

- Test certificates for routine type tests are to be furnished by the vendor.
- Type test certificate shall not be earlier than 10 years from the date of Purchase enquiry (or) as mentioned in Technical specification. In case of difference in Type test validity period, Technical specification shall prevail.
- Vendor to give tentative inspection program in advance and confirm exact date two weeks in advance for arranging BHEL's inspection.
- Packing shall be as per the "PACKING PROCEDURE" indicated in the specification.

C. REFERENCE STANDARDS:

(For Indicated Standards Refer the Latest Version)



IS 60529 : Degree of protection provided by enclosures (IP code)

SQP60R2.DOC

**BHARAT HEAVY ELECTRICALS LIMITED
TIRUCHIRAPPALLI**

**CONTROLS AND INSTRUMENTATION / FB
QUALITY ASSURANCE**

**STANDARD PACKING PROCEDURE
FOR
ELECTRICAL AND ELECTRONIC PANELS
(INCLUDING BOXES, CABINETS, CUBICLES, SYSTEMS AND CHASSIS)**

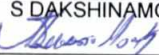
| Rev | Date | Prepared | Checked | Approved | Revision History |
|-----|------------|--|--|---|--|
| 00 | 01.01.96 | Sd/- | Sd/- | Sd/- | Initial History |
| 01 | 28.03.02 | A.J.OMPRAKASH Sd/- | R.VARADARAJAN Sd/- | G.MATHIYALAGAN Sd/- | Department name changed |
| 02 | 26.02.07 | RM.VAIRAVAN | N.SRIDHAR | S.SOMASUNDARAM | Revised after discussion with Shipping Dept. |
| 03 | 07.02.2017 | AVINASH V  | RM VAIRAVAN  | S DAKSHINAMOORTHY  | Type of wood for packing changed |

1.0 SCOPE

- 1.1 This procedure gives minimum guidelines to be complied with for packing of Electrical, Electronics and Instrumentation panels. This packing shall be suitable for different handling operations and for the adverse conditions during transportation and during indoor / outdoor storage for periods more than one year.

2.0 WOOD SPECIFICATION FOR PACKING

- 2.1 Any seasoned wood or plywood as per relevant international standard
2.2 Sea worthy packing is envisaged for international shipments.

3.0 PACKING

- 3.1 Any seasoned wood or plywood shall be used .It shall be free from knots, etc. and any kind of decay caused by insects and fungus.
- 3.2 The required wood case for the equipment to be packed shall be made out of individual planks of single length and no joint is permissible. Using such planks, the required wood case for the panel shall be made,
- 3.3 Sufficient number horizontal, vertical and diagonal planks (dimension depending upon case size) shall be used for binding and strengthening. Runners have to be provided with metallic sling plates for handling.
- 3.4 Support planks are to be provided such that, no force is acting on the parts of equipment or its parts.
- 3.5 Panels above 1.5 metre shall be bolted at the bottom.
- 3.6 The equipments covered with a polythene sheet shall be kept inside the box, followed by coir, wooden bottoms, thermo coal, etc to prevent vibration effect during loading, transportation, etc.
- 3.7 On all sides of the inner case, black polythene sheet shall be nailed.
- 3.8 Loose items of the equipment, if any, shall be packed separately.
- 3.9 Delicate components likely to be damaged, example PCB – Electronic modules, instrument, etc are to be covered individually in anti-static bags and packed in cartons and filled with fillers like thermo coal, paper cuttings, etc.
- 3.10 Such cartons shall be packed with overall polythene rapping and packed in wooden cases. Mark prominently as "ELECTRONIC COMPONENTS".

4.0 MARKING

- 4.1 After completing the packing, Stencil marking, as per dispatch instructions and symbol marking as per Annexure – I shall be made. Please ensure the box is stenciled with "FRAGILE ITEM", "HANDLE WITH CARE"

5.0 PACKING SLIP

- 5.1 A copy of the packing slip, kept in a polythene cover shall be kept inside the box. Another copy of the packing slip, kept in a polythene cover shall be kept out side the box and covered with a metallic plate to the case.

6.0 CAUTION

Do not pack any other Mechanical items with this case.

7.0 GENERAL

- 7.1 These packing procedures are the minimum requirements in addition to the standard instructions mentioned in the Purchase Order and Specification.

ANNEXURE - 1

TO

PROCEDURE NO:CI:QAC:PR:02/00 ; PR:03/00 ; PR:04/00

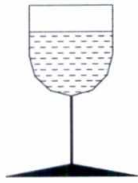

FRAGILE, HANDLE WITH CARE

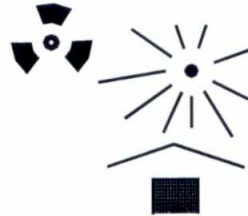

PROTECT FROM HEAT AND RADIOACTIVE SOURCES



USE NO HOOKS

NOTE: The design of heavy goods packages cannot always resist top lifting by grabhooks.



KEEP DRY

NOTE: Not all cases have waterproof internal liners: plywood used in the construction may not have a waterproof glueline.

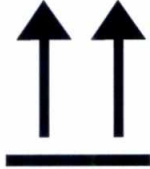

THIS WAY UP

NOTE: Certain designs of small cases make it difficult to distinguish top from bottom.

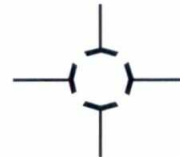

CENTRE OF GRAVITY

NOTE: This should be stencilled as a minimum on the two longest case sides (this information will normally be supplied by the manufacturer of the item(s) packed).

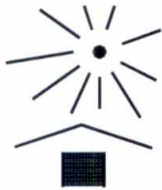

KEEP AWAY FROM HEAT

... kg max

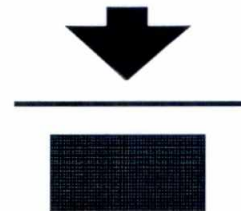

STACKING LIMITATION

NOTE: The maximum load in kilograms should be marked above the arrow.



INTERNATIONAL "SLING HERE" SYMBOL

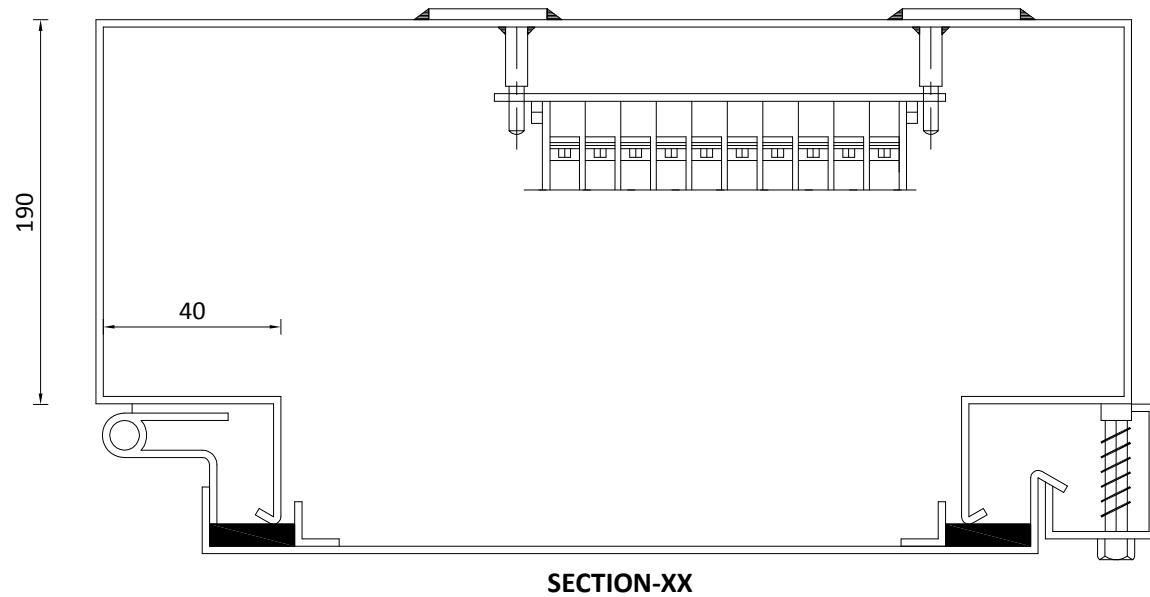
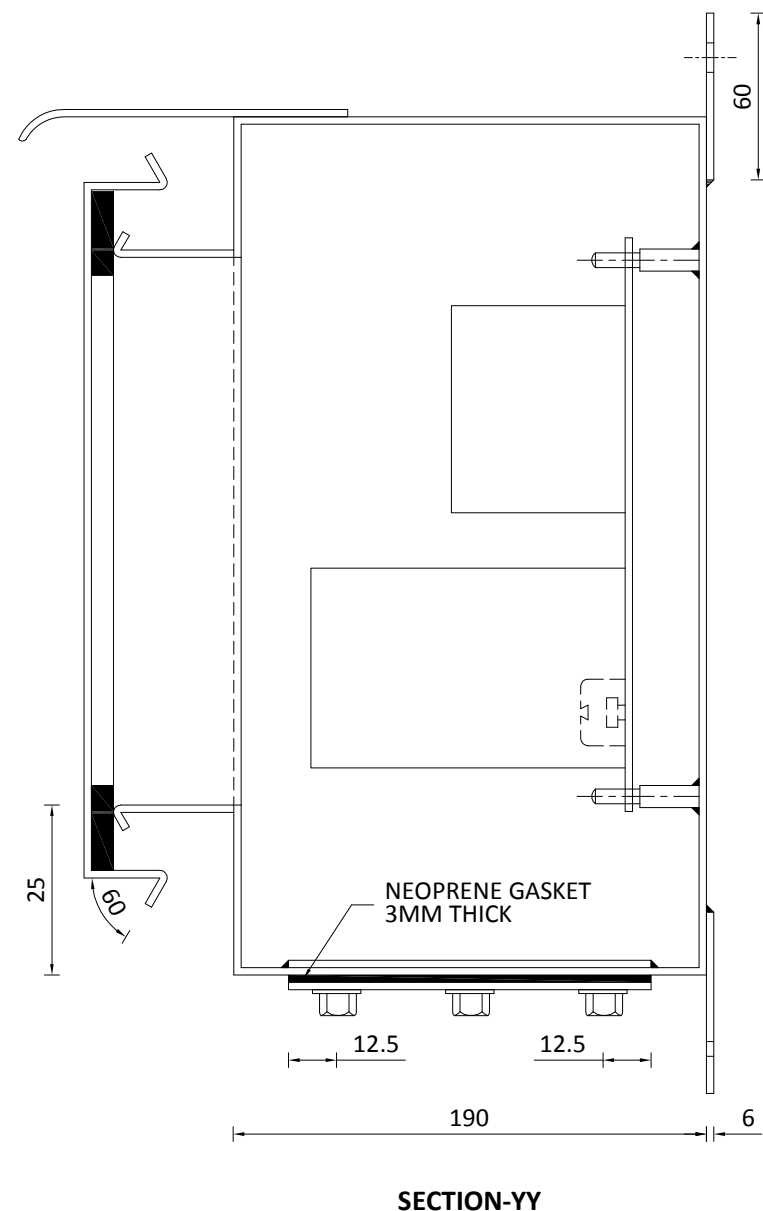
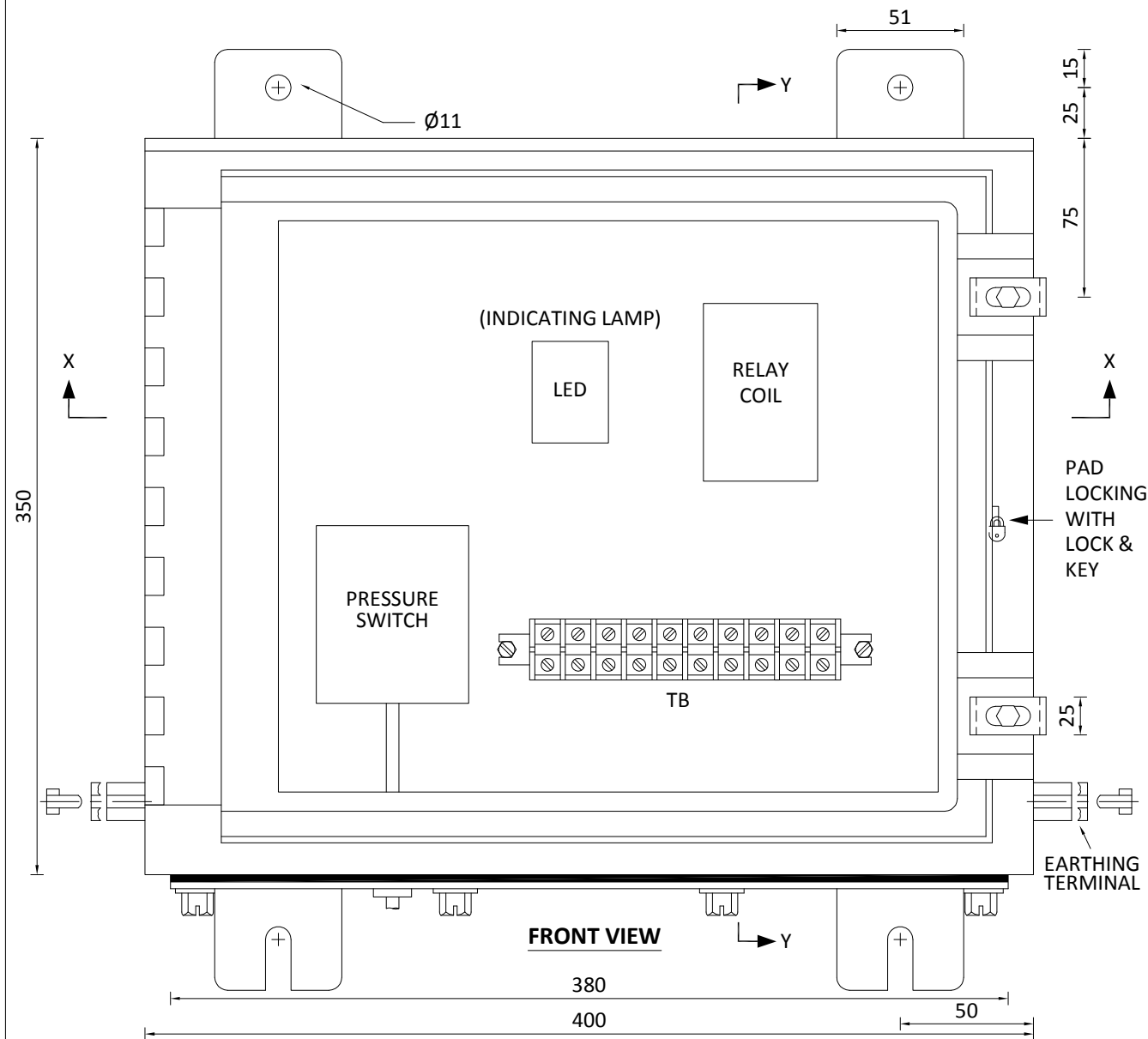

| | | | |
|---|-------------|---|------------------------|
| REV 07 | DATE 160620 | ALTERED : அ.சு.வேல் 160620 | CHD./APPD. : |
| REVISED AFTER REVISIT. | | | |
| REV 06 | DATE 110210 | ALTERED : அ.சு.வேல் 110210 | CHD./APPD. : Sd./SK-RD |
| REV 05 | DATE 220809 | ALTERED : அ.சு.வேல் 220809 | CHD./APPD. : Sd./SK-RD |
| REV 04 | DATE 220104 | ALTERED : அ.சு.வேல் 220104 | CHD./APPD. : Sd./MS-RD |
| GENERAL REVISION, REARRANGEMENT OF TBs AND RELAY & NOTES UPDATED. | | GENERAL REVISION, RESISTANCE DELETED AND NOTES UPDATED. | |
| GENERAL REVISION FOR RATE CONTRACT | | | |

| | | | | | | | | | | | |
|--------------------------|-------------|----------------------------|--------------------------|--|-------------|----------------------------|----------------------|--|-------------|----------------------------|----------------------|
| REV 03 | DATE 271299 | ALTERED : அ.சு.வேல் 271299 | CHD./APPD. : Sd./VSN-KCM | REV 02 | DATE 120499 | ALTERED : அ.சு.வேல் 120499 | CHD./APPD. : Sd./KCM | REV 01 | DATE 281097 | ALTERED : அ.சு.வேல் 281097 | CHD./APPD. : Sd./KCM |
| BOX DIMENSION CORRECTED. | | | | RELAY TYPE NO CORRECTED IN NOTE NO : 9 | | | | REF. DRG. No. REVISED IN NOTE 14 & 16. | | | |

| | | | | |
|---------------------|-----------------|--------------------------------------|----------|-------|
| TIRUCHIRAPPALLI | S T A N D A R D | | | |
| | DEPT. : C&I | TITLE | | |
| | CODE : 392 | ELECTROMATIC RELIEF VALVE CONTROLLER | | |
| DRN. | NAME | SIGNATURE | DATE | SCALE |
| CHD. | A.Thamburaj | அ.சு.வேல் 1110496 | 11-04-96 | NTS |
| APPD. | K.Chandramohan | Sd. / KCM | 22-04-96 | |
| | S.Jayaprakash | Sd. / SJP | 22-04-96 | |
| SHEET NO. | DRAWING NO. : | | | REV |
| 01/01 | 3-97-577-09562 | | | 07 |

THE INFO ON THIS DOCUMENT IS THE PROPERTY OF BHEL. IT MUST NOT BE USED DIRECTLY OR INDIRECTLY IN ANY WAY DETRIMENTAL TO THE INTEREST OF BHEL

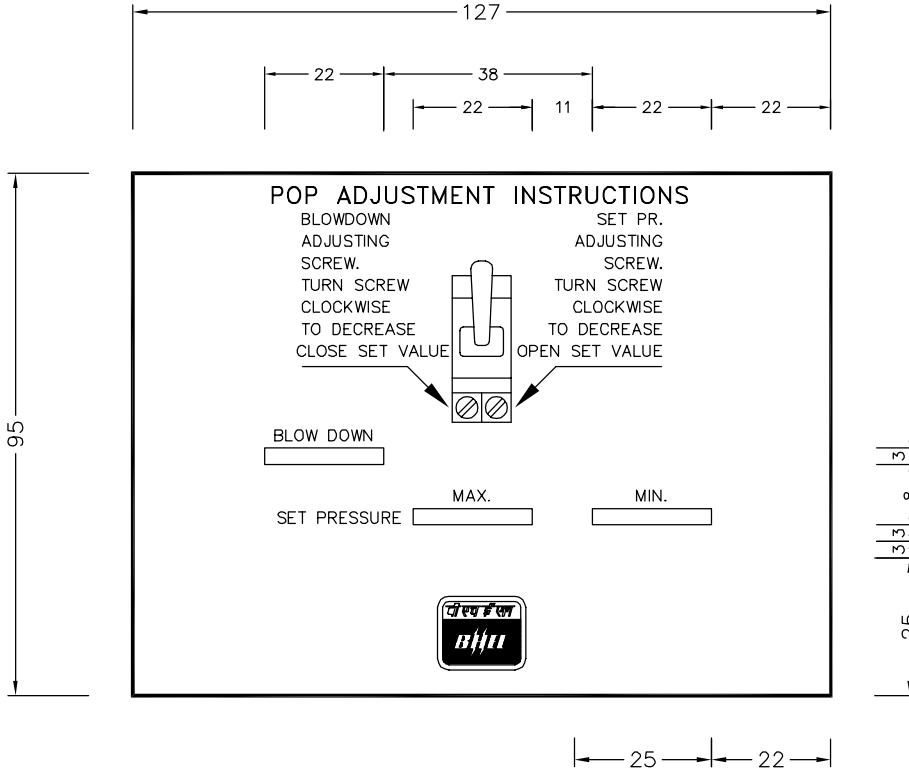

| | | | | | |
|------------------|--------|----------------------------------|-------------------|--------|----------------------------------|
| REV | DATE | ALTERED : <i>अ.श्रीधर</i> 250809 | REV | DATE | ALTERED : <i>अ.श्रीधर</i> 030211 |
| 02 | 250809 | CHD./APPD. : Sd./SKS-RD | 03 | 030211 | CHD./APPD. : |
| GENERAL REVISION | | | GENERAL REVISION. | | |



NOTE

1. 1 MM THICK ALUMINIUM PLATE BLACK ENAMEL LETTER ON WHITE BACKGROUND.
2. UNLESS OTHERWISE SPECIFIED ALL LETTER HEIGHTS TO BE 2.5 MM. (MIN.)
3. THE EMBLEM SHALL BE BASED ON CORP. STD. MONOGRAM15-AA 0401120.
4. EMBLEM SHOULD BE PLACED IN SPACING 127 X 25 AS SHOWN (CENTRED)

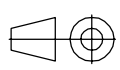
S T A N D A R D

| | | | | | | | |
|---|---|-------|---|----------------------------------|-------------------------|----------|-------------|
|  | Bharat Heavy Electricals Ltd UNIT: HIGH PRESSURE BOILER PLANT TIRUCHIRAPALLI - 620014 | | DRN | NAME | SIGNATURE | DATE | NO. OF VAR |
| | | | CHD | A.Thamburaj | <i>अ.श्रीधर</i> 1281097 | 28-10-97 | |
| | | | APPD | V.Sridharan | Sd. / VSN | 31-10-97 | — |
| DEPT. : C & I |  | SCALE | REF TO ASSY / OLD DWG | | | ITEM NO | No OF ITEMS |
| CODE : 392 | | NTS |  | | | — | — |
| TITLE : | | | CARD CODE | DRAWING NO : | | | REV |
| ERV CONTROLLER INSTRUCTION PLATE | | | U 01 | 4-97-577-10226 Sheet 01 of 01 | | | 03 |

THE INFERN ON THIS DOCUMENT IS THE PROPERTY OF BHEL- IT MUST NOT BE USED DIRECTLY OR INDIRECTLY IN ANY WAY DETRIMENTAL TO THE INTEREST OF BHEL

| | | | | | |
|------------------------------------|----------------|--|------------------|----------------|--|
| REV 01 | DATE 220104 | ALTERED : <i>g. g. g.</i> 220104 CHD./APPD. : Sd./MS-RD | REV 02 | DATE 220809 | ALTERED : <i>g. g. g.</i> 220809 CHD./APPD. : |
| GENERAL REVISION FOR RATE CONTRACT | | | GENERAL REVISION | | |

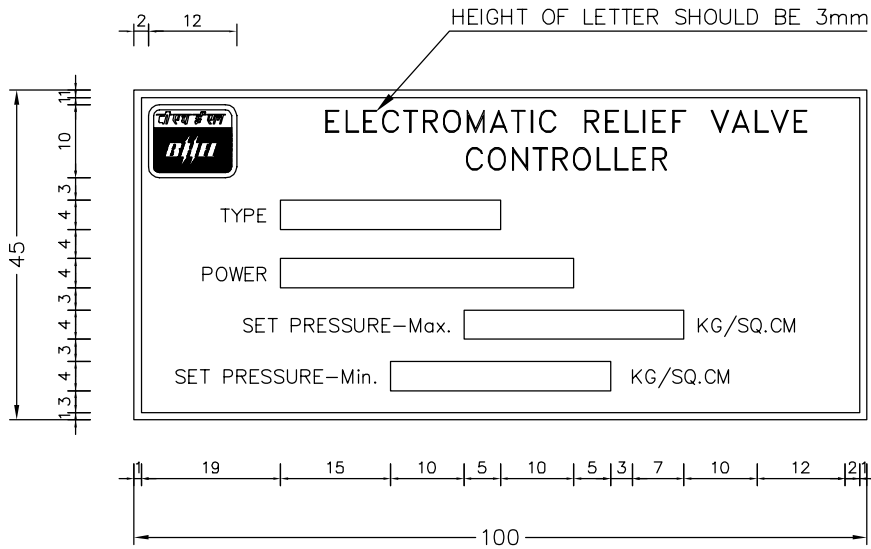

NOTE

1. MATERIAL: - ALUMINIUM t = 0.53MM (0.021")
2. UNLESS OHERWISE SPECIFIED ALL LETER HEIGHTS TO BE 1.5 MM (MIN)
3. UNLESS OTHERWISE SPECIFIED FIGURES, SPACES,AND BORDER TO BE RAISED AND BUFFED ON A WHITE BACKGROUND.
4. THE EMBLEM SHALL BE BASED ON CORP. STD. MONOGRAM 10 - AA0401120-REV.:01

S T A N D A R D

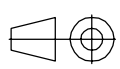
| | | | | | | | |
|---|---|--------------|----------------------|------------------------------------|--------------------------------------|------------------|----------------|
|  | Bharat Heavy Electricals Ltd UNIT: HIGH PRESSURE BOILER PLANT TIRUCHIRAPALLI - 620014 | | DRN | NAME A.Thamburaj | SIGNATURE <i>g. g. g.</i> 1281097 | DATE 28-10-97 | NO. OF VAR |
| | | | CHD | V.Sridharan | Sd. / VSN | 31-10-97 | --- |
| | | | APPD | K.Chandramohan | Sd. / KCM | 31-10-97 | --- |
| DEPT. : C & I |  | SCALE NTS | WEIGHT (Kg) | REF TO ASSY / OLD DWG | | ITEM NO | No OF ITEMS |
| CODE : 392 | | | | | | | |
| TITLE : ERV NAME PLATE | | | CARD CODE U 01 | DRAWING NO : 4-97-577-10225 | | | REV 02 |
| | | | | | | | Sheet 01 of 01 |

CONTROL SUPPLY FROM
DCS TO RELAY COIL RC
(220 or 110 V DC **)

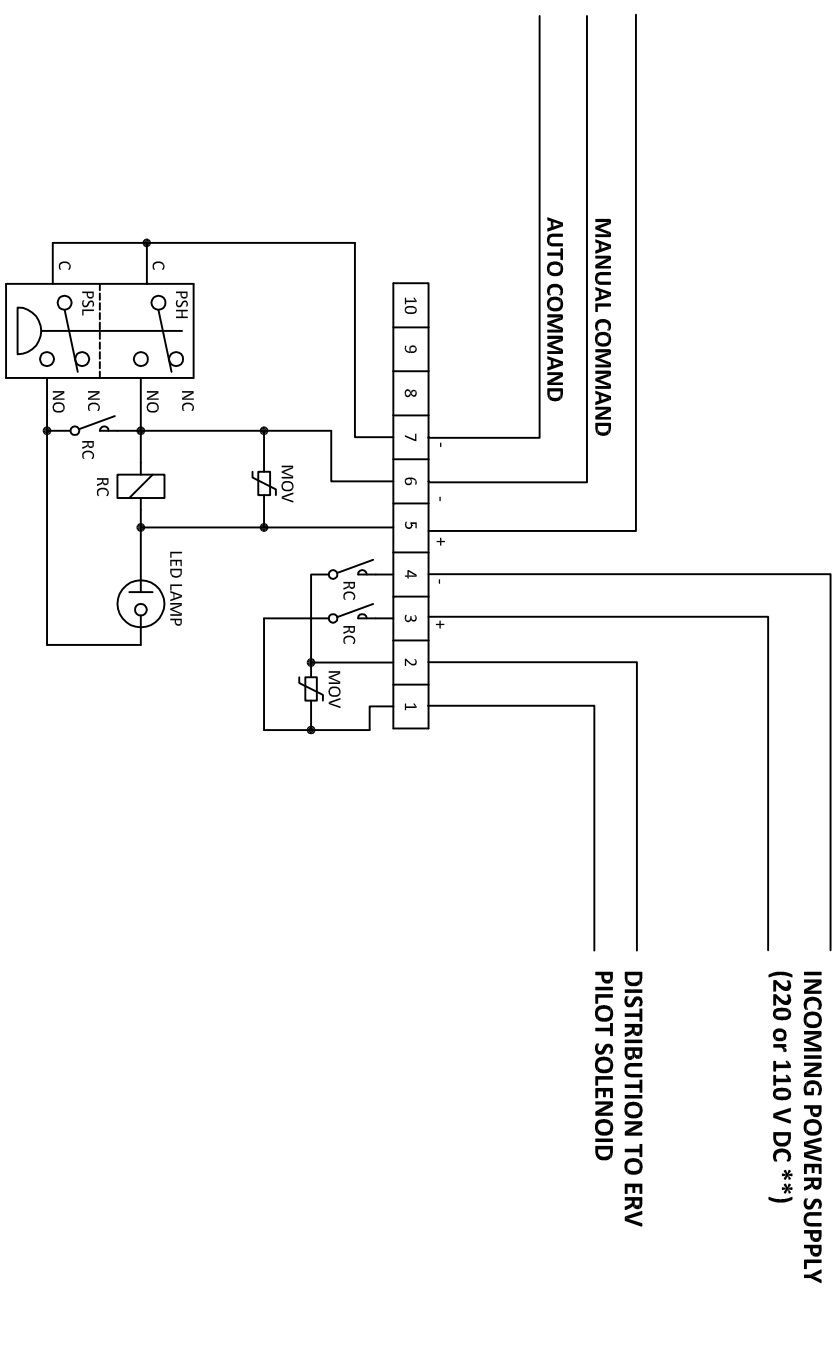

LEGEND
RC - RELAY COIL
MOV - METAL OXIDE VARISTOR
** POWER SUPPLY DETAILS WILL BE PROJECT SPECIFIC.

| REV | DATE | ALTERED : | MIMP/-sd- |
|------------------------|--------|-----------------------|-----------|
| 04 | 090321 | CHD./APPD. : AKP/-sd- | |
| ZONE : GENERAL REVISIT | | | |

CAUTION : The information on this document is the property of BHARAT HEAVY ELECTRICALS LTD. It must not be used directly or indirectly in any way detrimental to the interest of the company.

STANDARD

| | | | |
|---------------------------|--------------------------|--|-----------------------|
| | | Bharat Heavy Electricals Ltd UNIT: HIGH PRESSURE BOILER PLANT TRUCHIRAPPALLI - 620014 | |
| DEPT. : C & I | ALL DIMENSIONS ARE IN MM | SCALE : NTS | WEIGHT (kg) |
| CODE : 392 | | | |
| DRN : M. MURUGA PRABU | CHD : M. MURUGA PRABU | APPD : ASWINI KUMAR PANDA | REF TO ASSY / OLD DWG |
| NAME : M. MURUGA PRABU | SIGNATURE : -sd- | DATE : 09-03-2021 | NO. OF VARS : - |
| NAME : ASWINI KUMAR PANDA | SIGNATURE : -sd- | DATE : 09-03-2021 | NO. OF VARS : - |

**ELECTROMATIC RELIEF VALVE
CONTROLLER WIRING DRAWING**

| | | | |
|-------|-----------|----------------|-----|
| TITLE | CARD CODE | DRAWING NO. : | REV |
| | U 01 | 3-97-577-09565 | 04 |

**BHARAT HEAVY ELECTRICALS LIMITED
TIRUCHIRAPPALLI-620 014.**

Buyer Added Bid Specific Additional Terms & Conditions (ATC)

Note: This Annexure has to be mandatorily filled & signed by the manufacturer (or) mill and submitted along with Technical bid.

Any deviation to the below mentioned terms shall be stated specifically in the comments column for each term and also in case of acceptance to our terms, it will be construed that the whole term is understood and agreed in totality without any deviation. (If otherwise mentioned).

| SI No | BHEL Requirements | Supplier Comments | | | | | | | | | | | | |
|-----------|--|-------------------|------------|------------------|-----------|-----|-----------|--|--|--|--|--|--|--|
| 01 | <p>Pre-Qualification Criteria:</p> <p>1.1 Technical</p> <p>a) The supplier should meet tender technical specification requirement</p> <p>b) The vendor should meet the qualifying criteria as per CI:PE: PQR: CTRL BOXES Rev: No. 02 dated 15.07.2023</p> <p>c) Vendor should have already executed Purchase orders of Electrical items like Electrical Control panels or Motor Starter boxes, prior to the date of Techno-Commercial bid opening.</p> <p>d) Bidder shall have the facility to conduct the testing of Motor starter boxes or Control panels as per the enquiry.</p> <p>e) Vendor should supply the items as per the technical specification as per TDC: TCI:250, Rev. 00.</p> <p>1.2 Not Applicable</p> <p>1.3 Not Applicable</p> <p>1.4 Bidder must not be admitted under Corporate Insolvency Resolution Process or Liquidation as on date, by NCLT or any adjudicating authority/authorities, and shall submit undertaking (Annexure-4) to this effect.</p> <p>1.5 Not applicable.</p> <p>Explanatory Notes for the PQR:</p> <p>i. 'Supplied' in PQR – 1.1 means, bidder should have delivered the tender item. Bidder shall submit the relevant documents against the above PQRs inclusive of Purchase order (wherein PO no., date, etc. is legible) along with proof of supply (i.e. - Completion Certificate/ Copy of Invoices / LR Copies/ Store Receipt Vouchers/ Payment Advice etc.) in the respective attachments in their offer in support of PQR. The "Contract" referred in Technical PQR may be Rate Contract/ Framework Agreement/ Purchase Order/ Work Order.</p> <p>ii. Bidder to submit Audited Balance Sheet and Profit and Loss Account for the respective years as indicated against Financial Turnover PQR – 1.2 above along with all annexures.</p> <p>iii. In case of audited Financial Statements have not been submitted for all the three years as indicated against Financial Turnover PQR above, then the applicable audited statements submitted by the bidders against the requisite three years, will be averaged for three years i.e. total divided by three.</p> <p>iv. If Financial Statements are not required to be audited statutorily, then instead of audited Financial Statements, Financial Statements are required to be certified by Chartered Accountant.</p> <p>v. Credentials furnished by the bidder against "PRE-QUALIFYING CRITERIA" shall be verified from the issuing authority for its authenticity. In case, any credential (s) is/are found to be spurious, offer of the bidder is liable to be rejected. BHEL reserves the right to initiate any further action as per extant guidelines for Suspension of Business Dealings as applicable in BHEL.</p> <p>vi. Price Bids of only those bidders shall be opened who stand qualified after compliance of QR – 1.1 to 1.5</p> | | | | | | | | | | | | | |
| 02 | <p>Scope of Supply:</p> <p>Supply of ERV Controller box for RH Application shall be on F.O.R. Destination Basis as per the following:</p> <table border="1" style="width: 100%; border-collapse: collapse;"> <thead> <tr> <th style="text-align: center;">Sl. No.</th> <th style="text-align: center;">Matrl Code</th> <th style="text-align: center;">Matrl Decription</th> <th style="text-align: center;">Qty</th> <th style="text-align: center;">UOM</th> <th style="text-align: center;">Supply to</th> </tr> </thead> <tbody> <tr> <td> </td> <td> </td> <td> </td> <td> </td> <td> </td> <td> </td> </tr> </tbody> </table> | Sl. No. | Matrl Code | Matrl Decription | Qty | UOM | Supply to | | | | | | | |
| Sl. No. | Matrl Code | Matrl Decription | Qty | UOM | Supply to | | | | | | | | | |
| | | | | | | | | | | | | | | |

| | | | | | | | |
|----|---|--------------|---------------------------------------|---|-----|--------------------|--|
| | 1 | R61172500003 | ERV Controller Box for RH Application | 2 | Nos | BHEL Stores Trichy | |
| | | | Total Qty | 2 | | | |
| | Unloading of materials at Destination / Site shall be in BHEL's scope. | | | | | | |
| 03 | <p>PRICE BASIS: Price in INR should be quoted for FOR Destination – FOR BHEL Stores Trichy GSTIN : will be issued along with MDCC There will not be any reverse auction for this tender, hence, bidders are requested quote their best rates at the first instance.</p> | | | | | | |
| 04 | <p>TAXES & DUTIES:</p> <p>4.1 The Supplier/Vendor shall pay all (save the specific exclusions as enumerated in this clause) taxes, fees, license, charges, deposits, duties, tools, royalty, commissions, other charges, etc. which may be levied on the input goods & services consumed and output goods & services delivered in course of his operations in executing the contract. In case BHEL is forced to pay any of such taxes/duties, BHEL shall have the right to recover the same from his bills or otherwise as deemed fit along with the applicable overheads @5% and interest on the total value (i.e. amount paid by BHEL + overhead).</p> <p>However, provisions regarding GST on output supply (goods/service) and TDS/TCS as per Income Tax Act shall be as per following clauses.</p> <p>4.2 GST (Goods and Services Tax)</p> <p>4.2.1 GST as applicable on output supply (goods/services) are excluded from Supplier/Vendor's scope; therefore, contractor's price/rates shall be exclusive of GST. Reimbursement of GST is subject to compliance of following terms and conditions. BHEL shall have the right to deny payment of GST and to recover any loss to BHEL on account of tax, interest, penalty etc. for non-compliance of any of the following condition.</p> <p>4.2.2 The admissibility of GST, taxes and duties referred in this chapter or elsewhere in the contract shall be limited to direct transactions between BHEL & its Supplier/Vendor. BHEL shall not consider GST on any transaction other than the direct transaction between BHEL & its Supplier/Vendor.</p> <p>4.2.3 Supplier/Vendor shall obtain prior written consent of BHEL before billing the amount towards such taxes. Where the GST laws permit more than one option or methodology for discharging the liability of tax/levy/duty, BHEL shall have the right to adopt the appropriate one considering the amount of tax liability on BHEL/Client as well as procedural simplicity with regard to assessment of the liability. The option chosen by BHEL shall be binding on the Contractor for discharging the obligation of BHEL in respect of the tax liability to the Supplier/Vendor.</p> <p>4.2.4 Supplier/Vendor has to submit GST registration certificate of the concerned state. Supplier/Vendor also needs to ensure that the submitted GST registration certificate should be in active status during the entire contract period.</p> <p>4.2.5 Supplier/Vendor has to issue Invoice/Debit Note/Credit Note indicating HSN/SAC code, Description, Value, Rate, applicable tax and other particulars in compliance with the provisions of relevant GST Act and Rules made thereunder.</p> <p>4.2.6 Supplier/Vendor has to submit GST compliant invoice within the due date of invoice as per GST Law. In case of delay, BHEL reserves the right of denial of GST payment if there occurs any hardship to BHEL in claiming the input thereof. In case of goods, Supplier/Vendor has to provide scan copy of invoice & GR/LR/RR to BHEL before movement of goods starts to enable BHEL to meet its GST related compliances. Special care should be taken in case of month end transactions.</p> <p>4.2.7 Supplier/Vendor has to ensure that invoice in respect of such services which have been provided/completed on or before end of the month should not bear the date later than last working day of the month in which services are performed.</p> <p>4.2.8 Subject to other provisions of the contract, GST amount claimed in the invoice shall be released on fulfilment of all the following conditions by the Supplier/Vendor: - a) Supply of goods and/or services have been received by BHEL.</p> | | | | | | |

- b) Original Tax Invoice has been submitted to BHEL.
- c) Supplier/Vendor has submitted all the documents required for processing of bill as per contract/ purchase order/ work order.
- d) In cases where e-invoicing provision is applicable, Supplier/Vendor is required to submit invoice in compliance with e-invoicing provisions of GST Act and Rules made thereunder.
- e) Supplier/Vendor has filed all the relevant GST return (e.g. GSTR-1, GSTR-3B, etc.) pertaining to the invoice submitted and submit the proof of such return along with immediate subsequent invoice. In case of final invoice/ bill, contractor has to submit proof of such return within fifteen days from the due date of relevant return.
- f) Respective invoice has appeared in BHEL's GSTR - 2A for the month corresponding to the month of invoice and in GSTR-2B of the month in which such invoices has been reported by the contractor along with status of ITC availability as "YES" in GSTR-2B. Alternatively, BG of appropriate value may be furnished which shall be valid at least one month beyond the due date of confirmation of relevant payment of GST on GSTN portal or sufficient security is available to adjust the financial impact in case of any default by the Supplier/Vendor.
- g) Supplier/Vendor has to submit an undertaking confirming the payment of all due GST in respect of invoices pertaining to BHEL.

4.2.9 Any financial loss arises to BHEL on account of failure or delay in submission of any document as per contract/purchase order/work order at the time of submission of Tax invoice to BHEL, shall be deducted from Supplier/Vendor's bill or otherwise as deemed fit.

4.2.10 TDS as applicable under GST law shall be deducted from Supplier/Vendor's bill.

4.2.11 Supplier/Vendor shall comply with the provisions of e-way bill wherever applicable. Further wherever provisions of GST Act permits, all the e-way bills, road permits etc. required for transportation of goods needs to be arranged by the contractor.

4.2.12 Supplier/Vendor shall be solely responsible for discharging his GST liability according to the provisions of GST Law and BHEL will not entertain any claim of GST/interest/penalty or any other liability on account of failure of Supplier/Vendor in complying the provisions of GST Law or discharging the GST liability in a manner laid down thereunder.

4.2.13 In case declaration of any invoice is delayed by the vendor in his GST return or any invoice is subsequently amended/alterd/deleted on GSTN portal which results in any adverse financial implication on BHEL, the financial impact thereof including interest/penalty shall be recovered from the Supplier/Vendor's due payment.

4.2.14 Any denial of input credit to BHEL or arising of any tax liability on BHEL due to non-compliance of GST Law by the Supplier/Vendor in any manner, will be recovered along with liability on account of interest and penalty (if any) from the payments due to the Supplier/Vendor.

4.2.15 In the event of any ambiguity in GST law with respect to availability of input credit of GST charged on the invoice raised by the contractor or with respect to any other matter having impact on BHEL, BHEL's decision shall be final and binding on the Supplier/Vendor.

4.2.16 Variation in Taxes & Duties:

Any upward variation in GST shall be considered for reimbursement provided supply of goods and services are made within schedule date stipulated in the contract or approved extended schedule for the reason solely attributable to BHEL. However downward variation shall be subject to adjustment as per actual GST applicability.

In case the Government imposes any new levy/tax on the output service/goods after price bid opening, the same shall be reimbursed by BHEL at actual. The reimbursement under this clause is restricted to the direct transaction between BHEL and its Supplier/Vendor only and within the contractual delivery period only.

In case any new tax/levy/duty etc. becomes applicable after the date of Bidder's offer but before opening of the price Bid, the Bidder/ Supplier/Vendor must convey its impact on his price duly substantiated by documentary evidence in support of the same before opening of price bid. Claim for any such impact after opening the price bid will not be considered by BHEL for reimbursement of tax or reassessment of offer.

4.3 Income Tax:

TDS/TCS as applicable under Income Tax Act, 1961 or rules made thereunder shall be deducted/collected from Supplier/Vendor's bill.

| | | |
|-----------|--|-----------------|
| | 4.4 Supplier HSN Code & Applicable GST % (To be filled by Supplier) _____ | |
| 05 | MATERIAL DISPATCH CLEARANCE CERTIFICATE (MDCC): MDCC shall be issued by BHEL. No material shall be dispatched by supplier unless and until Material Dispatch Clearance Certificate (MDCC) issued by BHEL Site. In case any material is dispatched without MDCC and any loss is incurred by Supplier/Vendor for any reason whatsoever, BHEL shall not be responsible in any manner to compensate the supplier in this regard. | |
| 06 | INSPECTION / INSPECTION & TESTING AT SUPPLIERS WORKS: BHEL reserves the right to inspect the material during manufacturing and also to get tested the material under dispatch from third party. The test results of third party test shall be final and binding on the Supplier/Vendor. BHEL will reserve the right to inspect/test the material during/after manufacturing at suppliers' works, and/or at BHEL Site. In case of rejection at any stage, Supplier/Vendor shall be liable to replace the materials at his own cost. | |
| 07 | DELIVERY: 150 days from PO (including Manufacturing, Inspection, Packing, Forwarding and delivery at project site/stores) for each boiler. Material shall be dispatched after obtaining dispatch clearance from BHEL. NOTE: a) If the delivery of supply as detailed above gets delayed beyond the delivery period, the Supplier/Vendor shall request for a delivery extension and BHEL at its discretion may extend the Contract. However, if any 'Delivery extension' is granted to the Supplier/Vendor for completion of supply, due to backlog attributable to the Supplier/Vendor, then it shall be without prejudice to the rights of BHEL to impose LD for the delays attributable to the Supplier/Vendor. b) In case BHEL increase the quantity during currency of the contract in line with quantity variation clause, delivery extension shall be given for supply of these additional quantity. | |
| 08 | TRANSIT INSURANCE: Transit Insurance of material is in BHEL scope. | |
| 09 | PAYMENT TERMS: A) i) FOR NON MSME Bidders, 100% payment shall be released within 90 days ii) FOR MSE Bidders, 100% payment shall be released within 45 days iii) FOR MEDIUM ENTERPRISES Bidders, 100% payment shall be released within 60 days Date for reckoning Payment due date 1. For Direct to Site (DTS), due date will be considered from the Site Acknowledgement date (Against submission of GST invoice, invoice, LR copy, e-Way Bill for full load/ latest e-way bill for part load, site acknowledgement and as per Cl.No.10 given below) 2. For Dispatch to BHEL Trichy Stores, due date will be considered from the material acceptance date (Against submission of GST invoice, invoice and as per Cl.No.10 given below) However, GST amount shall be reimbursed in line with compliance to Cl. No. 4 (Taxes & Duties) above. b) NO INTEREST PAYABLE TO CONTRACTOR No interest shall be payable on the security deposit or any other money due to the Supplier. | |
| 10 | DOCUMENTS REQUIRED FOR BILL PROCESSING: The following documents are required to be sent with Material Dispatch/Billing Documents: <ul style="list-style-type: none"> • Original Tax Invoice (As per Cl. No. 4 above). • Original Consignee copy of LR • Site acknowledged copy of LR • e-Way Bill for full load/ latest e-way bill for part load | |
| 11 | BANK DETAILS FOR EMD & PERFORMANCE SECURITY SUBMISSION: | Not Applicable. |
| 12 | EARNEST MONEY DEPOSIT: | Not Applicable. |

| | | |
|----|---|-----------------|
| | | |
| 13 | PERFORMANCE SECURITY: | Not Applicable. |
| 14 | <p>BREACH OF CONTRACT, REMEDIES AND TERMINATION:</p> <p>14.1 The following shall amount to breach of contract:</p> <ol style="list-style-type: none"> I. Non-supply of material/ non-completion of work by the Supplier/Vendor within scheduled delivery/ completion period as per contract or as extended from time to time. II. The Supplier/Vendor fails to perform as per the activity schedule and there are sufficient reasons even before expiry of the delivery/ completion period to justify that supplies shall be inordinately delayed beyond contractual delivery/ completion period III. The Supplier/Vendor delivers equipment/ material not of the contracted quality. IV. The Supplier/Vendor fails to replace the defective equipment/ material/ component as per guarantee clause. V. Withdrawal from or abandonment of the work by the Supplier/Vendor before completion as per contract. VI. Assignment, transfer, subletting of Contract by the Supplier/Vendor without BHEL's written permission resulting in termination of Contract or part thereof by BHEL. VII. Non-compliance to any contractual condition or any other default attributable to Supplier/Vendor. VIII. Any other reason(s) attributable to Vendor towards failure of performance of contract. In case of breach of contract, BHEL shall have the right to terminate the Purchase Order/ Contract either in whole or in part thereof without any compensation to the Supplier/Vendor. IX. Any of the declarations furnished by the contractor at the time of bidding and/ or entering into the contract for supply are found untruthful and such declarations were of a nature that could have resulted in non-award of contract to the contractor or could expose BHEL and/ or Owner to adverse consequences, financial or otherwise. X. Supplier/Vendor is convicted of any offence involving corrupt business practices, antinational activities or any such offence that compromises the business ethics of BHEL, in violation of the Integrity Pact entered into with BHEL has the potential to harm the overall business of BHEL/ Owner. <p>Note- Once BHEL considers that a breach of contract has occurred on the part of Supplier/Vendor, BHEL shall notify the Supplier/Vendor by way of notice in this regard. Contractor shall be given an opportunity to rectify the reasons causing the breach of contract within a period of 14 days. In case the contractor fails to remedy the breach, as mentioned in the notice, to the satisfaction of BHEL, BHEL shall have the right to take recourse to any of the remedial actions available to it under the relevant provisions of contract.</p> <p>14.2 Remedies in case of Breach of Contract.</p> <ol style="list-style-type: none"> i. Wherein the period as stipulated in the notice issued under clause 14.1 has expired and Supplier/Vendor has failed to remedy the breach, BHEL will have the right to terminate the contract on the ground of "Breach of Contract" without any further notice to contractor. ii. Upon termination of contract, BHEL shall be entitled to recover an amount equivalent to 10% of the Contract Value for the damages on account of breach of contract committed by the Supplier/Vendor. This amount shall be recovered by way of encashing the security instruments like performance bank guarantee etc available with BHEL against the said contract. In case the value of the security instruments available is less than 10% of the contract value, the balance amount shall be recovered from other financial remedies (i.e. available bills of the Supplier/Vendor, retention amount, from the money due to the Supplier/Vendor etc. with BHEL) or the other legal remedies shall be pursued. iii. wherever the value of security instruments like performance bank guarantee available with BHEL against the said contract is 10% of the contract value or more, such security instruments to the extent of 10% contract value will be encashed. In case no security instruments are available or the value of the security instruments available is less than 10% of the contract value, the 10% of the contract value or the balance amount, as the case may be, will be recovered in all or any of the following manners: iv. In case the amount recovered under sub clause (a) above is not sufficient to fulfil the amount recoverable then; a demand notice to deposit the balance amount within 30 days shall be issued to Supplier/Vendor. | |

| | | |
|----|---|--|
| | <p>v. If Supplier/Vendor fails to deposit the balance amount within the period as prescribed in demand notice, following action shall be taken for recovery of the balance amount:</p> <p>a) from dues available in the form of Bills payable to defaulted Supplier/Vendor against the same contract.</p> <p>b) If it is not possible to recover the dues available from the same contract or dues are insufficient to meet the recoverable amount, balance amount shall be recovered from any money(s) payable to Supplier/Vendor under any contract with other Units of BHEL including recovery from security deposits or any other deposit available in the form of security instruments of any kind against Security deposit or EMD.</p> <p>vi. In-case recoveries are not possible with any of the above available options, Legal action shall be initiated for recovery against defaulted supplier/Vendor.</p> <p>vii. It is an agreed term of contract that this amount shall be a genuine pre-estimate of damages that BHEL would incur in completion of balance contractual obligation of the contract through any other agency and BHEL will not be required to furnish any other evidence to the Supplier/Vendor for the purpose of estimation of damages.</p> <p>viii. In addition to the above, imposition of liquidated damages, debarment, termination, de-scoping, short-closure, etc., shall be applied as per provisions of the contract.</p> <p>Note:</p> <p>1) The defaulting Supplier/Vendor shall not be eligible for participation in any of the future enquiries floated by BHEL to complete the balance work. The defaulting contractor shall mean and include:</p> <p>(a) In case defaulted Supplier/Vendor is the Sole Proprietorship Firm, any Sole Proprietorship Firm owned by same Sole Proprietor.</p> <p>(b) In case defaulted Supplier/Vendor is The Partnership Firm, any firm comprising of same partners/ some of the same partners; or sole proprietorship firm owned by any partner(s) as a sole proprietor.</p> <p>LD against delay in executed supply in case of Termination of Contract:</p> <p>LD against delay in executed supply shall be calculated in line with LD clause no. 18.0 below, for the delay attributable to Supplier/Vendor. For limiting the maximum value of LD, contract value shall be taken as Executed Value of supply till termination of contract.</p> <p>Method for calculation of “LD against delay in executed supply in case of termination of contract” is given below.</p> <p>i. Let the time period from scheduled date of start of supply till termination of contract excluding the period of Hold (if any) not attributable to contractor = T1</p> <p>ii. Let the value of executed supply till the time of termination of contract= X</p> <p>iii. Let the Total Executable Value of supply for which inputs/fronts were made available to Supplier/Vendor and were planned for execution till termination of contract = Y</p> <p>iv. Delay in executed supply attributable to Supplier/Vendor i.e. $T2 = [1 - (X/Y)] \times T1$</p> <p>v. LD shall be calculated in line with LD clause (clause 18.0) of the Contract for the delay attributable to Supplier/Vendor taking “X” as Contract Value and “T2” as period of delay attributable to Supplier/Vendor.</p> | |
| 15 | <p>BILL TO/ SHIP TO ADDRESS:</p> <p>Bill to: BHEL Trichy</p> <p>Ship to: BHEL Stores Trichy</p> | |
| 16 | <p>GUARANTEE/WARRANTY:</p> <p>Guarantee period for Supply of ERV Controller Box for RH Application shall be 12 calendar months from the date of last dispatch.</p> | |
| 17 | <p>MICRO AND SMALL ENTERPRISES (MSE):</p> <p>Any Bidder falling under MSE category shall furnish the following details & submit documentary evidence/ Govt. Certificate etc. in support of the same along with their techno-commercial offer.</p> | |

| Type under MSE | UDYAM No | SC/ST Owned | Women Owned | Others (Excluding SC/ST/Women) |
|----------------|----------|-------------|-------------|--------------------------------|
| Micro | | | | |
| Small | | | | |

Note: If the bidder does not furnish the above, offer shall be processed construing that the bidder is not falling under MSE category.

a) MSE suppliers can avail the intended benefits in respect of the procurements related to the Goods and Services only (Definition of Goods and Services as enumerated by Govt. of India vide Office Memorandum F. No. 21(8)/2011-MA dtd. 09/11/2016 office of AS & DC, MSME) only if they submit along with the offer, attested copies of either Udyam Registration. Date to be reckoned for determining the deemed validity will be the last date of Technical Bid submission. Non-submission of supporting document in portal will lead to consideration of their bids at par with other bidders. No benefits shall be applicable for this enquiry if the above required documents are not uploaded at the time of bid submission. Documents submitted by the bidder shall be verified by BHEL for rendering the applicable benefits.

b) Material entry date (Gate Entry date) will be considered for payment due date calculation (when no objections are raised by BHEL). If such objection(s) is raised within 15 days of zero date /last closure of objection and payment due date will be accordingly revised considering date on which vendor has successfully replied against objection as zero date.

c) As per the public procurement policy notified by the central government, micro and small enterprises quoting within the price band of L1 +15% shall be allowed to supply a portion of the requirement up to 25% of the tender value subject to condition that such enterprises bring down their price to L1 price where L1 price is from other than a micro and small enterprise. If L1 offer is from a micro / small enterprise, this provision will not be applicable.

18 LIQUIDATED DAMAGE:

Liquidated Damages, wherever referred under this Tender/Agreement, shall mean and refer to the damages, not in the nature of penalty, which the contractor agrees to pay in the event of delay in delivery of supplies, breach of contract etc. as the case may be.

Liquidated Damages leviable upon the Supplier/Vendor is a sum which is agreed by the parties as a reasonable and genuine pre-estimate of damages which will be suffered by BHEL on account of delay/breach on the part of the Supplier/Vendor.

If the Seller/Service Provider fails to deliver any or all of the Goods/Services within the original/re-fixed delivery period(s) specified in the contract/PO, the Buyer/BHEL will be entitled to deduct/recover the Liquidated Damages for the delay, unless covered under Force Majeure conditions aforesaid, @ 0.5% of the contract value of delayed quantity per week or part of the week of delayed period, until actual delivery or performance, as pre-estimated damages not exceeding 10% of the total contract value without any controversy/dispute of any sort whatsoever.

LD shall be reckoned from the Contract delivery date to material receipt date.

Material receipt date means the following

Direct to Site (DTS)- Site Acknowledgement date

Dispatch to BHEL Trichy Stores- Vehicle Entry date

19 INTEGRITY PACT (IP):

Not applicable

20 PREFERENCE TO MAKE IN INDIA:

For this procurement, the local content to categorize a Supplier/Vendor as a Class I local supplier/ Class II local Supplier/Non-Local Supplier and purchase preferences to Class I local supplier, is as defined in Public Procurement (Preference to Make in India), Order 2017 dated 04.06.2020 issued by DPIIT. In case of subsequent orders issued by the nodal ministry, changing the definition of local content for the items of the Bid, the same shall be applicable even if issued after issue of this Bid, but before opening of Part-II bids against this Bid.

23.1 Compliance to Restrictions under Rule 144 (xi) of GFR 2017:

I. Any bidder from a country which shares a land border with India will be eligible to bid in this tender only if the bidder is registered with the Competent Authority. The Competent Authority for the purpose of this

| | | |
|------------------|---|--|
| | <p>Clause shall be the Registration Committee constituted by the Department for Promotion of Industry and Internal Trade (DPIIT).</p> <p>II. "Bidder" (including the term 'tenderer', 'consultant' or 'service provider' in certain contexts) means any person or firm or company, including any member of a consortium or joint venture (that is an association of several persons, or firms or companies), every artificial juridical person not falling in any of the descriptions of bidders stated hereinbefore, including any agency branch or office controlled by such person, participating in a procurement process.</p> <p>III. "Bidder from a country which shares a land border with India" for the purpose of this Clause means: -</p> <ol style="list-style-type: none"> a. An entity incorporated established or registered in such a country; or b. A subsidiary of an entity incorporated established or registered in such a country; or c. An entity substantially controlled through entities incorporated, established or registered in such a country; or d. An entity whose beneficial owner is situated in such a country; or e. An Indian (or other) agent of such an entity; or f. A natural person who is a citizen of such a country; or g. A consortium or joint venture where any member of the consortium or joint venture falls under any of the above. <p>IV. The beneficial owner for the purpose of (III) above will be as under:</p> <ol style="list-style-type: none"> 1. In case of a company or Limited Liability Partnership, the beneficial owner is the natural person(s), who, whether acting alone or together or through one or more juridical person, has a controlling ownership interest or who exercises control through other means. <p>Explanation</p> <ol style="list-style-type: none"> a. "Controlling ownership interest" means ownership of or entitlement to more than twenty-five per cent of shares or capital or profits of the company. b. "Control" shall include the right to appoint majority of the directors or to control the management or policy decisions including by virtue of their shareholding or management rights or shareholders agreements or voting agreements. <ol style="list-style-type: none"> 2. In case of a partnership firm, the beneficial owner is the natural person(s) who, whether acting alone or together, or through one or more juridical person, has ownership of entitlement to more than fifteen percent of capital or profits of the partnership. 3. In case of an unincorporated association or body of individuals, the beneficial owner is the natural person(s), who, whether acting alone or together, or through one or more juridical person has ownership of or entitlement to more than fifteen percent of the property or capital or profits of the such association or body of individuals. 4. Where no natural person is identified under (1) or (2) or (3) above, the beneficial owner is the relevant natural person who holds the position of senior managing official; 5. In case of a trust, the identification of beneficial owner(s) shall include identification of the author of the trust, the trustee, the beneficiaries with fifteen percent or more interest in the trust and any other natural person exercising ultimate effective control over the trust through a chain of control or ownership. <ol style="list-style-type: none"> (i) The bidder shall provide undertaking for their compliance to this Clause, in the format provided in Annexure-13. (ii) Registration of the bidder with Competent Authority should be valid at the time of submission of bids and at the time of acceptance of the bids | |
| <p>21</p> | <p>Settlement of Dispute:</p> <p>If any dispute or difference of any kind whatsoever shall arise between BHEL and the Supplier/Vendor, arising out of the contract for the performance of the work whether during the progress of contract termination, abandonment or breach of the contract, it shall in the first place referred to Designated Engineer for amicable resolution by the parties. Designated Engineer (to be nominated by BHEL for settlement of disputes arising out of the contract) who within 60 days after being requested shall give written notice of his decision to the contractor. Save as hereinafter provided, such decision in respect of every matter so referred shall forthwith be given effect to by the Supplier/Vendor who shall proceed with the work with all due diligence, whether he or BHEL desires to resolve the dispute as hereinafter provided or not.</p> | |

If after the Designated Engineer has given written notice of this decision to the party and no intention to pursue the dispute has been communicated to him by the affected party within 30 days from the receipt of such notice, the said decision shall become final and binding on the parties. In the event the Supplier/Vendor being dissatisfied with any such decision or if amicable settlement cannot be reached then all such disputed issues shall be resolved through conciliation in terms of the BHEL Conciliation Scheme 2018 as per Clause 21.1

21.1 Conciliation:

Any dispute, difference or controversy of whatever nature howsoever arising under or out of or in relation to this Agreement (including its interpretation) between the Parties, and so notified in writing by either Party to the other Party (the "Dispute") shall, in the first instance, be attempted to be resolved amicably in accordance with the conciliation procedure as per BHEL Conciliation Scheme 2018. The proceedings of Conciliation shall broadly be governed by Part-III of the Arbitration and Conciliation Act 1996 or any statutory modification thereof and as provided in - "Procedure for conduct of conciliation proceedings" (as available in www.bhel.com)).

Note: Ministry of Finance has issued OM reference No. 1/2/24 dated 03.06.2024 regarding "Guidelines for Arbitration and Mediation in Contracts of Domestic Public Procurement. In the said OM it has been recommended that Government departments/ Entities/agencies are to encourage mediation under the Mediation Act. 2023. The said Act has not yet been notified by the Government. Therefore, the clause "Settlement of Disputes" shall be modified accordingly as and when the Mediation Act 2023 gets notified.

21.2 ARBITRATION:

21.2.1 Except as provided elsewhere in this Contract, in case Parties are unable to reach amicable settlement (whether by Conciliation to be conducted as provided in Clause 14.1 herein above or otherwise) in respect of any dispute or difference; arising out of the formation, breach, termination, validity or execution of the Contract; or, the respective rights and liabilities of the Parties; or, in relation to interpretation of any provision of the Contract; or, in any manner touching upon the Contract (hereinafter referred to as the 'Dispute'), then, either Party may, refer the disputes to **Madras High Court, Arbitration Centre (MHCAC)** and such dispute to be adjudicated by Sole Arbitrator appointed in accordance with the Rules of said Arbitral Institution.

21.2.2 A party willing to commence arbitration proceeding shall invoke Arbitration Clause by giving notice to the other party in terms of section 21 of the Arbitration & Conciliation Act, 1996 (hereinafter referred to as the 'Notice') before referring the matter to arbitral institution. The Notice shall be addressed to the Head of the Unit, BHEL, executing the Contract and shall contain the particulars of all claims to be referred to arbitration with sufficient detail and shall also indicate the monetary amount of such claim including interest, if any.

21.2.3 After expiry of 30 days from the date of receipt of aforesaid notice, the party invoking the Arbitration shall submit that dispute to the Arbitral Institution- **Madras High Court, Arbitration Centre (MHCAC)**- and that dispute shall be adjudicated in accordance with their respective Arbitration Rules. The matter shall be adjudicated by a Sole Arbitrator who shall necessarily be a Retd Judge having considerable experience in commercial matters to be appointed/nominated by the respective institution. The cost/expenses pertaining to the said Arbitration shall also be governed in accordance with the Rules of the respective Arbitral Institution. The decision of the party invoking the Arbitration for reference of dispute to **Madras High Court, Arbitration Centre (MHCAC)**- for adjudication of that dispute shall be final and binding on both the parties and shall not be subject to any change thereafter. The institution once selected at the time of invocation of dispute shall remain unchanged.

21.2.4 The fee and expenses shall be borne by the parties as per the Arbitral Institutional rules.

21.2.5 The Arbitration proceedings shall be in English language and the seat of Arbitration shall be **Trichy**.

21.2.6 Subject to the above, the provisions of Arbitration & Conciliation Act 1996 and any amendment thereof shall be applicable. All matters relating to this Contract and arising out of invocation of Arbitration clause are subject to the exclusive jurisdiction of the Court(s) situated at **Trichy**.

21.2.7 Notwithstanding any reference to the Designated Engineer or Conciliation or Arbitration herein, a. the parties shall continue to perform their respective obligations under the Contract unless they otherwise agree. Settlement of Dispute clause cannot be invoked by the Contractor, if the Contract has been mutually

| | | |
|----|--|--|
| | <p>closed or 'No Demand Certificate' has been furnished by the Contractor or any Settlement Agreement has been signed between the Employer and the Contractor.</p> <p>21.2.8 It is agreed that Mechanism of resolution of disputes through arbitration shall be available only in the cases where the value of the dispute is less than Rs. 10 Crores.</p> <p>21.2.9 In case the disputed amount Claim, Counter claim including interest is Rs. 10 crores and above, the parties shall be within their rights to take recourse to remedies other than Arbitration, as may be available to them under the applicable laws after prior intimation to the other party. Subject to the aforesaid conditions, provisions of the Arbitration and Conciliation Act, 1996 and any statutory modifications or re-enactment thereof as amended from time to time, shall apply to the arbitration proceedings under this clause.</p> <p>21.2.10 In case, multiple arbitrations are invoked (whether sub-judice or arbitral award passed) by any party to under this contract, then the cumulative value of claims (including interest claimed or awarded) in all such arbitrations shall be taken in account while arriving at the total claim in dispute for the subject contract for the purpose of clause 14.2.9. Disputes having cumulative value of less than 10 crores shall be resolved through arbitration and any additional dispute shall be adjudicated by the court of competent jurisdiction.</p> <p>21.3 In case of Contract with Public Sector Enterprise (PSE) or a Government Department, the following shall be applicable:</p> <p>In the event of any dispute or difference relating to the interpretation and application of the provisions of commercial contract(s) between Central Public Sector Enterprises (CPSEs)/ Port Trusts inter se and also between CPSEs and Government Departments/Organizations (excluding disputes concerning Railways, Income Tax, Customs & Excise Departments), such dispute or difference shall be taken up by either party for resolution through AMRCD (Administrative Mechanism for Resolution</p> | |
| 22 | <p>JURISDICTION</p> <p>Subject to clause 21 of this contract, the Civil Court having original Civil Jurisdiction at Tiruchirappalli, Tamilnadu shall alone have exclusive jurisdiction in regard to all matters in respect of the Contract.</p> <p>GOVERNING LAWS</p> <p>The contract shall be governed by the Law for the time being in force in the Republic of India.</p> | |
| 23 | <p>FORCE MAJEURE</p> <p>23.1 "Force Majeure" shall mean circumstance which is:</p> <ol style="list-style-type: none"> a) beyond control of either of the parties to contract, b) either of the parties could not reasonably have provided against the event before entering into the contract, c) having arisen, either of the parties could not reasonably have avoided or overcome, and d) not substantially attributable to either of the parties and Prevents the performance of the contract, such circumstances include but shall not be limited to: <ol style="list-style-type: none"> i. War, hostilities, invasion, act of foreign enemies. ii. Rebellion, terrorism, revolution, insurrection, military or usurped power, or civil war. iii. Riot, commotion or disorder by persons other than the contractor's personnel and other employees of the contractor and sub-contractors. iv. Strike or lockout not solely involving the contractor's personnel and other employees of the contractor and sub-contractors. v. Encountering munitions of war, explosive materials, ionizing radiation or contamination by radio-activity, except as may be attributable to the contractor's use of such munitions, explosives, radiation or radio- activity. vi. Natural catastrophes such as earthquake, tsunami, volcanic activity, hurricane or typhoon, flood, fire, cyclones etc. vii. Epidemic, pandemic etc. <p>23.2 The following events are explicitly excluded from Force Majeure and are solely the responsibilities of the non-performing party: a) any strike, work-to-rule action, go-slow or similar labour difficulty (b) late delivery of equipment or material (unless caused by Force Majeure event) and (c) economic hardship.</p> <p>23.3 If either party is prevented, hindered or delayed from or in performing any of its obligations under the Contract by an event of Force Majeure, then it shall notify the other in writing of the occurrence of such event and the circumstances thereof within 15 (fifteen) days after the occurrence of such event.</p> | |

| | | | | | | |
|----------------------------|---|-----------------|-------------|----------------------------|------------------------------|--|
| | <p>23.4 The party who has given such notice shall be excused from the performance or punctual performance of its obligations under the Contract for so long as the relevant event of Force Majeure continues and to the extent that such party's performance is prevented, hindered or delayed. The Time for Completion shall be extended by a period of time equal to period of delay caused due to such Force Majeure event.</p> <p>23.5 Delay or non-performance by either party hereto caused by the occurrence of any event of Force Majeure shall not</p> <p style="padding-left: 40px;">i) Constitute a default or breach of the Contract. ii) Give rise to any claim for damages or additional cost expense occasioned thereby, if and to the extent that such delay or non-performance is caused by the occurrence of an event of Force Majeure.</p> <p>23.6 BHEL at its discretion may consider short closure of contract after 1 year of imposition of Force Majeure in line with extant guidelines. In any case, Supplier/Vendor cannot consider deemed short-closure after 1 year of imposition of Force Majeure.</p> | | | | | |
| 24 | <p>Non-Disclosure Agreement: The bidders shall enter into the Non-disclosure agreement separately. (Annexure 7 attached).</p> | | | | | |
| 25 | <p>Cartel Formation</p> <p>The Bidder declares that they will not enter into any illegal or undisclosed agreement or understanding, whether formal or informal with other Bidder(s). This applies in particular to prices, specifications, certifications, subsidiary contracts, submission or non-submission of bids or any other actions to restrict competitiveness or to introduce cartelization in the bidding process. In case, the Bidder is found having indulged in above activities, suitable action shall be taken by BHEL as per extant policies/ guidelines.</p> | | | | | |
| 26 | <p>Fraud Prevention Policy</p> <p>Bidder along with its associate /collaborators /sub-contractors /sub-vendors / consultants / service providers shall strictly adhere to BHEL Fraud Prevention Policy displayed on BHEL website http://www.bhel.com and shall immediately bring to the notice of BHEL Management about any fraud or suspected fraud as soon as it comes to their notice.</p> | | | | | |
| 27 | <p>Suspension of Business Dealings with Suppliers / Contractors:</p> <p>The offers of the bidders who are under suspension as also the offers of the bidders, who engage the services of the banned firms / principal / agents, shall be rejected. The list of banned firms is available on BHEL website www.bhel.com.</p> <p>If any bidder / supplier / contractor during pre-tendering / tendering / post tendering / award /execution / post-execution stage indulges in any act, including but not limited to, mal-practices, cheating, bribery, fraud or and other misconduct or formation of cartel so as to influence the bidding process or influence the price or tampers the tendering process or acts or omits in any manner which tantamount to an offence punishable under any provision of the Indian Penal Code, 1860(Bhartiya Nyaya Samhita 2023) or any other law in force in India, or does anything which is actionable under the Guidelines for Suspension of Business dealings, action may be taken against such bidder / supplier / contractor as per extant guidelines of the company available on www.bhel.com and / or under applicable legal provisions. Guidelines for suspension of business dealings is available in the webpage: http://www.bhel.com/vender_registration/vender.php.</p> | | | | | |
| 28 | <p>Bid should be free from correction, overwriting, using corrective fluid, etc. Any interlineation, cutting, erasure or overwriting shall be valid only if they are attested under full signature(s) of person(s) signing the bid else bid shall be liable for rejection. In the event of any Technical or Commercial queries, the same may please be addressed to the following BHEL concerned before Part I opening-</p> <table border="1" data-bbox="161 1821 1334 1890"> <tr> <td data-bbox="161 1821 751 1854">Kevin Ark Kumar</td> <td data-bbox="751 1821 1334 1854">Fousiya E K</td> </tr> <tr> <td data-bbox="161 1854 751 1890">0431 2578109 kevin@bhel.in</td> <td data-bbox="751 1854 1334 1890">0431 2577362 fousiya@bhel.in</td> </tr> </table> | Kevin Ark Kumar | Fousiya E K | 0431 2578109 kevin@bhel.in | 0431 2577362 fousiya@bhel.in | |
| Kevin Ark Kumar | Fousiya E K | | | | | |
| 0431 2578109 kevin@bhel.in | 0431 2577362 fousiya@bhel.in | | | | | |
| 29 | <p>Order of Precedence:</p> <p>In the event of any ambiguity or conflict between the Tender Documents, the order of precedence shall be in the order below:</p> <ol style="list-style-type: none"> a. Amendments/Clarifications/Corrigenda/Errata etc. issued in respect of the tender documents by BHEL. b. Buyer Added Bid Specific ATC c. Bid Technical Conditions of Contract (TCC) | | | | | |

| | | |
|---------------------------|---|--|
| <p>30</p> | <p>Note:</p> <ol style="list-style-type: none"> 1. In the event of our customer order covering this tender being cancelled /placed on hold /otherwise modified, BHEL would be constrained to accordingly cancel / hold / modify the tender at any stage of execution. 2. BHEL may negotiate the L1 rate, if not meeting our budget / estimated cost. BHEL may re-float the tender opened, if L1 price is not acceptable to BHEL even after negotiation. Any deviation from the conditions specified in TECHNO-COMMERCIAL TERMS AND CONDITIONS - Annexure-A, will lead to rejection of offer. 3. Any change in applicable rates of Tax or any other statutory levies (Direct / Indirect) or any new introduction of any levy by means of statute and its corresponding liability for the deliveries beyond the agreed delivery date for reasons not attributable to BHEL will be to vendors account. BHEL will not reimburse the same and any subsequent claim in this respect will be summarily rejected. 4. BHEL reserves its right to reject an offer due to unsatisfactory past performance by the respective Vendor in the execution of any contract to any BHEL project / Unit. 5. The offers of the bidders who are under suspension and also the offers of the bidders, who engage the services of the banned firms /principal/agents, shall be rejected. The list of banned firms is available on BHEL web site www.bhel.com. 6. Recovery / deduction as applicable as per Direct and Indirect taxes as notified by Govt. Of India from time to time will be made and information/certificate for such deduction/recoveries shall be provided by BHEL to the vendor. | |
| <p>31</p> | <p>Enclosure:</p> <ul style="list-style-type: none"> Annexure-1: Check List. Annexure-2: Offer forwarding letter / tender submission letter Annexure-3: No Deviation Certificate Annexure-4: Declaration regarding Insolvency/ Liquidation/ Bankruptcy Proceedings Annexure-5: Declaration by Authorized Signatory Annexure-6: Declaration by Authorized Signatory regarding Authenticity of submitted Documents Annexure-7: Non-Disclosure Certificate Annexure-8: Integrity Pact Annexure-9: Declaration confirming knowledge about Site Conditions Annexure-10: Declaration reg. Related Firms & their areas of Activities Annexure-11: Declaration for relation in BHEL Annexure- 12: Declaration reg. minimum local content in line with revised public procurement Annexure- 13: Declaration regarding compliance to Restrictions under Rule 144 (xi) of GFR 2017 Annexure-14: Bank Account Details for E-Payment Annexure-15: Power of Attorney for submission of tender. Annexure-16: Proforma of Bank Guarantee for Earnest Money. Annexure-17: Proforma of Bank Guarantee for Performance Security. Annexure-18: List of Consortium Bank. | |
| <p>Signature and seal</p> | | |

ANNEXURE- 1CHECK LIST

NOTE: - Suppliers are required to fill in the following details in their Letterhead and no column should be left blank

| | | | |
|-------|---|--|--------------------|
| A | Name and Address of the Supplier | | |
| B | GSTN No. the Supplier (Place of Execution of Contract / Purchase Order) | | |
| C | Details of Contact person for this Tender | Name: Mr./ Ms. Designation: Telephone No: Mobile No: Email ID: | |
| D | EMD DETAILS | Not applicable | |
| E | DESCRIPTION | APPLICABILITY (BY BHEL) | ENCLOSED BY BIDDER |
| i. | Whether Pre - Qualification Criteria is understood and provided proper supporting documents. | Applicable | YES / NO |
| ii. | Whether all pages of the Tender documents including annexures, appendices etc are read and understood | Applicable | YES / NO |
| iii. | Audited Balance Sheet and profit & Loss Account for the last three years | Not Applicable | YES / NO |
| iv. | Copy of PAN Card & GST registration | Applicable | YES / NO |
| v. | Submission of MSE certificate as specified in Tender | If Applicable | YES / NO |
| vi. | Offer forwarding letter / tender submission letter as per Annexure 2 | Not Applicable | YES / NO |
| vii. | Submission of Certificate of No Deviation as per Annexure 3 | Applicable | YES / NO |
| viii. | Declaration regarding Insolvency/ Liquidation/ Bankruptcy Proceedings as per Annexure 4 | Applicable | YES / NO |
| ix. | Declaration by Authorized Signatory as per Annexure 5 | Not Applicable | YES / NO |
| x. | Declaration by Authorized Signatory regarding Authenticity of submitted Documents Annexure 6 | Not Applicable | YES / NO |

| | | | |
|--------|---|----------------|----------|
| xi. | Submission of Non-Disclosure Certificate as per Annexure 7 | Not Applicable | YES / NO |
| xii. | Submission of Integrity Pact as specified in Tender as per Annexure 8 | Not Applicable | YES / NO |
| xiii. | Declaration confirming knowledge about Site Conditions as per Annexure 9 | Applicable | YES / NO |
| xiv. | Declaration reg. Related Firms & their areas of Activities as per Annexure 10 | Applicable | YES / NO |
| xv. | Declaration for relation in BHEL as per Annexure 11 | Applicable | YES / NO |
| xvi. | Declaration reg. minimum local content in line with revised public procurement as per Annexure 12 | Not Applicable | YES / NO |
| xvii. | Declaration regarding compliance to Restrictions under Rule 144 (xi) of GFR 2017 as per Annexure 13 | Applicable | YES / NO |
| xviii. | Bank Account Details for E-Payment as per Annexure 14 | If Applicable | YES / NO |
| xix. | Power of Attorney for submission of tender as per Annexure 15 | Not Applicable | YES / NO |
| xx. | Proforma of Bank Guarantee for Earnest Money as per Annexure 16 | Not Applicable | YES / NO |

NOTE strike off 'YES' or 'NO', as applicable. Tender not accompanied by the prescribed above applicable documents are liable to be summarily rejected.

DATE :

Sign. of the AUTHORISED SIGNATORY
(With Name, Designation and Company seal)

ANNEXURE - 2**OFFER FORWARDING LETTER / TENDER SUBMISSION LETTER**

(To be typed and submitted in the Letter Head of the Company/Firm of Bidder)

Offer Reference No:

Date:

To,

(Write Name & Address of Officer of BHEL inviting the Tender)

Dear Sir,

Sub: Submission of Offer against GeM Bid No:

Having examined the tender documents against your GeM Bid No. _____ dated _____ and having understood the provisions of the said tender documents and having thoroughly studied the requirements of BHEL related to the work tendered for, in connection with _____ (name of work & project site), we hereby submit our offer for the proposed work in accordance with terms and conditions mentioned in the tender documents, at the prices quoted by us and as per the indicated delivery schedule.

Should our Offer be accepted by BHEL for Award, I/we further agree to furnish 'Performance Security' for the work as provided for in the Tender Conditions within the stipulated time as may be indicated by BHEL.

I/We further agree to execute all the works referred to in the said Tender documents upon the terms and conditions contained or referred to therein and as detailed in the appendices annexed thereto.

I/We have deposited herewith the requisite Earnest Money Deposit (EMD) as per details furnished in the Check List.

Authorised Representative of Bidder

Signature:

Name:

Address:

Place:

Date:

ANNEXURE- 3

CERTIFICATE OF NO DEVIATION

(To be Typed & submitted in the Letter Head of the Company/Firm of Bidder)

To,

(Write Name & Address of Officer of BHEL inviting the Tender)

Dear Sir,

Subject: **No Deviation Certificate**

Ref: 1) GeM Bid No:
2) All other pertinent issues till date

We hereby confirm that we have not changed/ modified/materially altered any of the tender documents as downloaded from the website/ issued by BHEL and in case of such observance at any stage, it shall be treated as null and void.

We also hereby confirm that we have neither set any Terms and Conditions and nor have we taken any deviation from the Tender conditions together with other references applicable for the above referred GeM Bid.

We further confirm our unqualified acceptance to all Terms and Conditions, unqualified compliance to Tender Conditions.

We confirm to have submitted offer in accordance with tender instructions and as per aforesaid references.

Thanking you,

Yours faithfully,

(Signature, date & seal of authorized representative of the bidder)

Date:
Place:

ANNEXURE- 4

UNDERTAKING

(To be typed and submitted in the Letter Head of the Company/Firm of Bidder)

To,

(Write Name & Address of Officer of BHEL inviting the Tender)

Dear Sir/Madam,

Sub: DECLARATION REGARDING INSOLVENCY/ LIQUIDATION/ BANKRUPTCY PROCEEDINGS

Ref: GeM Bid Specification No:

I/We, _____ declare that,

I/We am/are not admitted under insolvency resolution process or liquidation under Insolvency and Bankruptcy Code, 2016, as amended from time to time or under any other law as on date, by NCLT or any adjudicating authority/authorities.

**Sign. of the AUTHORISED SIGNATORY
(With Name, Designation and Company seal)**

Place:

Date:

ANNEXURE – 5

DECLARATION BY AUTHORISED SIGNATORY OF BIDDER

(To be typed and submitted in the Letter Head of the Company/Firm of Bidder)

To,

(Write Name & Address of Officer of BHEL inviting the Tender)

Dear Sir,

Sub: **Declaration by Authorised Signatory**

Ref: 1) GeM Bid Specification No:
2) All other pertinent issues till date

I/We, hereby certify that all the information and data furnished by me with regard to the above Tender Specification are true and complete to the best of my knowledge. I have gone through the specifications, conditions, stipulations and all other pertinent issues till date, and agree to comply with the requirements and Intent of the specification.

I further certify that I am authorised to represent on behalf of my Company/Firm for the above mentioned tender and a valid Power of Attorney to this effect is also enclosed.

Yours faithfully,

(Signature, Date & Seal of Authorized
Signatory of the Bidder)

Date:

Enclosed: Power of Attorney

ANNEXURE – 6

DECLARATION BY AUTHORISED SIGNATORY OF BIDDER

(To be typed and submitted in the Letter Head of the Company/Firm of Bidder)

To,

(Write Name & Address of Officer of BHEL inviting the Tender)

Dear Sir,

Sub : **Declaration by Authorised Signatory regarding Authenticity of submitted documents.**

Ref : 1) GeM Bid No. & Date:

2) All other pertinent issues till date

I/We, hereby certify that all the documents submitted by us in support of possession of "Qualifying Requirements" are true copies of the original and are fully compliant required for qualifying / applying in the bid and shall produce the original of same as and when required by Bharat Heavy Electricals Limited.

I / We hereby further confirm that no tampering is done with documents submitted in support of our qualification as bidder. I / We understand that at any stage (during bidding process or while executing the awarded contract) if it is found that fake / false / forged bid qualifying / supporting documents / certificates were submitted, it would lead to summarily rejection of our bid / termination of contract. BHEL shall be at liberty to initiate other appropriate actions as per the terms of the Bid / Contract and other extant policies of Bharat Heavy Electricals Limited.

Yours faithfully,

(Signature, Date & Seal of Authorized Signatory of the Bidder)

Date:

ANNEXURE- 7

NON-DISCLOSURE CERTIFICATE

(To be Typed & submitted in the Letter Head of the Company/Firm of Bidder)

I/We understand that BHEL <PS- Region> is committed to Information Security Management System as per their Information Security Policy.

Hence, I/We M/s
.....
who are submitting offer for providing services to BHEL <PS- Region> against GeM Bid No..... hereby undertake to comply with the following in line with Information Security Policy of <PS- Region>.

- To maintain confidentiality of documents & information which shall be used during the execution of the Contract.
- The documents & information shall not be revealed to or shared with third party which shall not be in the business interest of BHEL <PS- Region>.

(Signature, date & seal of Authorized Signatory of the bidder)

Date:

ANNEXURE – 9

DECLARATION CONFIRMING KNOWLEDGE ABOUT SITE CONDITIONS

(To be typed and submitted in the Letter Head of the Company/Firm of Bidder)

To,

(Write Name & Address of Officer of BHEL inviting the Tender)

Dear Sir,

Sub: Declaration confirming knowledge about Site conditions

Ref: 1) GeM Bid Specification No:

2) All other pertinent issues till date

I/We, _____ hereby declare and confirm that we have visited the Project Site as referred in BHEL Tender Specifications and acquired full knowledge and information about the Site conditions including Wage structure, Industrial Climate, the Law & Order and other conditions prevalent at and around the Site. We further confirm that the above information is true and correct and we shall not raise any claim of any nature due to lack of knowledge of Site conditions.

I/We, hereby offer to carry out work as detailed in above mentioned Tender Specification, in accordance with Terms & Conditions thereof.

Yours faithfully,

(Signature, Date & Seal of Authorized Representative of the Bidder)

Date:

Place:

ANNEXURE – 10**DECLARATION**

Date: _____

To,

(Write Name & Address of Officer of BHEL inviting the Tender)

Dear Sir/ Madam,

Sub: **Details of related firms and their area of activities**

Please find below details of firms owned by our family members that are doing business/ registered for same item with BHEL, _____ (NA, if not applicable)

| | | |
|-----|-------------------------------------|--|
| 1 | Material Category/ Work Description | |
| | Name of Firm | |
| | Address of Firm | |
| | Nature of Business | |
| | Name of Family Member | |
| | Relationship | |
| 2 | Material Category/ Work Description | |
| | Name of Firm | |
| | Address of Firm | |
| | Nature of Business | |
| | Name of Family Member | |
| | Relationship | |
| ... | | |

Note: I certify that the above information is true and I agree for penal action from BHEL in case any of the above information furnished is found to be false.

Regards,

(_____)

From: M/s _____

Supplier Code: _____

Address:

ANNEXURE – 11**DECLARATION FOR RELATION IN BHEL**

(To be typed and submitted in the Letter Head of the Company/Firm of Bidder failing which the offer of Bidder is liable to be summarily rejected)

To,

(Write Name & Address of Officer of BHEL inviting the Tender)

Dear Sir,

Sub: Declaration for relation in BHEL

Ref: 1) GeM Bid Specification No:

I/We hereby submit the following information pertaining to relation/relatives of Proprieter/Partner(s)/ Director(s) employed in BHEL

Tick (√) any one as applicable:

1. The Proprieter, Partner(s), Director(s) of our Company/Firm DO NOT have any relation or relatives employed in BHEL

OR

2. The Proprieter, Partner(s), or Director(s) of our Company/Firm HAVE relation/relatives employed in BHEL and their particulars are as below:

i.

ii.

**(Signature, Date & Seal of Authorized
Signatory of the Bidder)**

Note:

1. Attach separate sheet, if necessary.
2. If BHEL Management comes to know at a later date that the information furnished by the Bidder is false, BHEL reserves the right to take suitable against the Bidder/Contractor.

ANNEXURE – 12

**DECLARATION REGARDING MINIMUM LOCAL CONTENT IN LINE WITH
REVISED PUBLIC PROCUREMENT (PREFERENCE TO MAKE IN INDIA), ORDER 2017 DATED 04TH
JUNE, 2020 AND SUBSEQUENT ORDER(S)**

(To be typed and submitted in the Letter Head of the Entity/Firm providing certificate as applicable)

To,

(Write Name & Address of Officer of BHEL inviting the Tender)

Dear Sir,

Sub: Declaration reg. minimum local content in line with Public Procurement (Preference to Make in India), Order 2017-Revision, dated 04th June, 2020 and subsequent order(s).

Ref: 1) GeM Bid Specification No:
2) All other pertinent issues till date

We hereby certify that the items/works/services offered by..... *(specify the name of the organization here)* has a local content of _____ % and this meets the local content requirement for '**Class-I local supplier**' / '**Class II local supplier**' ** as defined in Public Procurement (Preference to Make in India), Order 2017-Revision dated 04.06.2020 issued by DPIIT and subsequent order(s).

The details of the location(s) at which the local value addition is made are as follows:

- | | |
|----------|----------|
| 1. _____ | 2. _____ |
| 3. _____ | 4. _____ |
| ... | |

Thanking you,
Yours faithfully,

**(Signature, Date & Seal of
Authorized Signatory of the Bidder)**

** - *Strike out whichever is not applicable.*

Note:

1. Bidders to note that above format, duly filled & signed by authorized signatory, shall be submitted along with the techno-commercial offer.
2. In case the bidder's quoted value is in excess of Rs. 10 crores, the authorized signatory for this declaration shall necessarily be the statutory auditor or cost auditor of the company (in the case of companies) or a practising cost accountant or practicing chartered accountant (in respect of suppliers other than companies).
3. In the event of false declaration, actions as per the above order and as per BHEL Guidelines shall be initiated against the bidder.

ANNEXURE – 13

DECLARATION REGARDING COMPLIANCE TO RESTRICTIONS UNDER RULE 144 (xi) OF GFR 2017

(To be typed and submitted in the Letter Head of the Entity/ Firm providing certificate as applicable)

To,

(Write Name & Address of Officer of BHEL inviting the Tender)

Dear Sir,

Sub: Declaration regarding compliance to Restrictions under Rule 144 (xi) of GFR 2017

Ref: 1) GeM Bid Specification No:
2) All other pertinent issues till date

I have read the clause regarding restrictions on procurement from a bidder of a country which shares a land border with India. I certify that _____ (**SPECIFY THE NAME OF THE ORGANIZATION HERE**), is not from such a country/ has been registered with the Competent Authority (*attach valid registration by the Competent Authority, i.e., the Registration Committee constituted by the Dept. for Promotion of Industry and Internal Trade (DPIIT).*)

I hereby certify that we fulfil all requirements in this regard and is eligible to be considered.

Thanking you,
Yours faithfully,

**(Signature, Date & Seal of
Authorized Signatory of the Bidder)**

Note: Bidders to note that in case above certification given by a bidder, whose bid is accepted, is found to be false, then this would be a ground for immediate termination and for taking further action in accordance with law and as per BHEL guidelines.

ANNEXURE – 14

BANK ACCOUNT DETAILS FOR E-PAYMENT

(To be given on Letter head of the Company /Firm of Bidder, and **ENDORSED (SIGNED & STAMPED)**
BY THE BANK to enable BHEL release payments through Electronic Fund Transfer (EFT/RTGS)

1. Beneficiary Name :

2. Beneficiary Account No. :

3. Bank Name & Branch :

4. City/Place :

5. 9 digit MICR Code of Bank Branch :

6. IFSC Code of Bank Branch :

7. Beneficiary E-mail ID :
(for payment confirmation)

NOTE: In case Bank endorsed certificate regarding above has already been submitted earlier, kindly submit photocopy of the same

ANNEXURE – 15

POWER OF ATTORNEY for SUBMISSION OF TENDER

(To be typed on non-judicial stamp paper of minimum Rs. 100/- and Notarized)

KNOW ALL MEN BY THESE PRESENTS, that I/We do hereby make, nominate, constitute and appoint Mr. , whose signature given below herewith to be true and lawful Attorney of M/s..... hereinafter called 'Company', for submitting Tender/entering into Contract and inter alia, sign, execute all papers and to do necessary lawful acts on behalf of Company with M/s Bharat Heavy Electricals Ltd, Central Procurement Cell (CPC), in connection with.....vide GeM Bid No: _____, dated _____.

And the Company do hereby agree to ratify and confirm all acts, deeds, things or proceedings as may be lawfully done by the said attorney and by or on behalf of the company and in the name of the company, by virtue of the powers conferred herein and the same shall be binding on the company and shall have full force and effect.

IN WITNESS WHEREOF, the common seal of the company has been hereunto affixed in the manner hereinafter appearing on the document.

Dated at _____, this _____ day of _____

Director/CMD/Partner/Proprietor

Signature of Mr. (Attorney)

Attested by: Director/CMD/Partner/Proprietor

Witness

Notary Public

ANNEXURE – 16**PROFORMA OF BANK GUARANTEE FOR EARNEST MONEY**

(On non-Judicial paper of appropriate value)

Bank Guarantee No.....**Date.....****To**

(Employer's Name and Address)

.....

Dear Sirs,

In accordance with the terms and conditions of Invitation for Bids/Notice Inviting Tender No.....¹(Tender Conditions), M/s. having its registered office at² (hereinafter referred to as the 'Tenderer'), is submitting its bid for the work of.....³ invited by⁴(name of the Employer) through its Unit at(

The Tender Conditions provide that the Tenderer shall pay a sum of Rs as Earnest Money Deposit in the form therein mentioned. The form of payment of Earnest Money Deposit includes Bank Guarantee executed by a Scheduled Bank.

In lieu of the stipulations contained in the aforesaid Tender Conditions that an irrevocable and unconditional Bank Guarantee against Earnest Money Deposit for an amount of⁵ is required to be submitted by the Tenderer as a condition precedent for participation in the said Tender and the Tenderer having approached us for giving the said Guarantee,

we, the[Name & address of the Bank]

..... having our Registered Office at

.....(hereinafter referred to as the Bank) being the Guarantor under this

Guarantee, hereby irrevocably and unconditionally undertake to forthwith and immediately pay to the Employer without any demur, merely on your first demand any sum or sums of Rs.

.....⁵ (in words Rupees.....) without any reservation, protest, and recourse and without the beneficiary needing to prove or demonstrate reasons for its such demand.

Any such demand made on the Bank shall be conclusive as regards the amount due and payable by the Bank under this guarantee. However, our liability under this guarantee shall be restricted to an amount not exceeding Rs. _____.

We undertake to pay to the Employer any money so demanded notwithstanding any dispute or disputes raised by the Vendor/Contractor/Vendors in any suit or proceeding pending before any Court or Tribunal, Arbitrator or any other authority, our liability under this present being absolute and unequivocal.

The payment so made by us under this Guarantee shall be a valid discharge of our liability for payment hereunder and the Tenderer shall have no claim against us for making such payment.

We Bank further agree that the Employer shall have the fullest liberty without our consent and without affecting in any manner our obligations hereunder to vary any of the terms and conditions of the said Tender or to extend the time of submission of from time to time or to postpone for any time or from time to time any of the powers exercisable by the Employer against the said Tenderer and we shall not be relieved from our liability by reason of any such variation, or extension being granted to the said Tenderer or for any forbearance, act or omission on the part of the Employer or any indulgence by the Employer to the said Tenderer or by any such matter or thing whatsoever which under the law relating to sureties would but for this provision have effect of so relieving us.

The Bank also agrees that the Employer at its option shall be entitled to enforce this Guarantee against the Bank as a principal debtor, in the first instance without proceeding against the Tenderer and notwithstanding any security or other guarantee that the Employer may have in relation to the Tenderer's liabilities.

This Guarantee shall be irrevocable and shall remain in force upto and including.....⁶ and shall be extended from time to time for such period as may be desired by the Employer.

This Guarantee shall not be determined or affected by liquidation or winding up, dissolution or change of constitution or insolvency of the Tenderer but shall in all respects and for all purposes be binding and operative until payment of all money payable to the Employer in terms hereof. However, unless a demand or claim under this Guarantee is made on us in writing on or before the⁷ we shall be discharged from all liabilities under this Guarantee.

This Bank Guarantee shall be governed, construed and interpreted in accordance with the laws of India.

Courts at shall alone have exclusive jurisdiction over any matter arising out of or in connection with this Bank Guarantee

We, Bank lastly undertake not to revoke this guarantee during its currency except with the previous consent of the Employer in writing.

Notwithstanding anything to the contrary contained hereinabove:

- a. The liability of the Bank under this Guarantee shall not exceed.....⁵
- b. This Guarantee shall be valid up to⁶

- c. Unless the Bank is served a written claim or demand on or before _____⁷ all rights under this guarantee shall be forfeited and the Bank shall be relieved and discharged from all liabilities under this guarantee irrespective of whether or not the original bank guarantee is returned to the Bank

We, _____ Bank, have power to issue this Guarantee under law and the undersigned as a duly authorized person has full powers to sign this Guarantee on behalf of the Bank.

For and on behalf of
(Name of the Bank)

Date.....

Place of Issue.....

¹ *Details of the Invitation to Bid/Notice Inviting Tender*

² *Name and Address of the Tenderer*

³ *Details of the Work*

⁴ *Name of the Employer*

⁵ *BG Amount in words and Figures*

⁶ *Validity Date*

⁷ *Date of Expiry of Claim Period*

Notes:

1. Units are advised that expiry of claim period may be kept 3-6 months after validity date. It may be ensured that the same is in line with the agreement/ contract entered with the Vendor.
2. The BG should be on Non-Judicial Stamp paper/e-stamp paper of appropriate value as per Stamp Act prevailing in the State(s) where the BG is submitted or is to be acted upon or the rate prevailing in the State where the BG was executed, whichever is higher. The Stamp Paper/e-stamp paper shall be purchased in the name of Contractor/sub-contractor /vendor/ Bank issuing the guarantee.
3. In line with the GCC, SCC or contractual terms, Unit may carry out minor modifications in the Standard BG Formats. If required, such modifications may be carried out after taking up appropriately with the Unit/Region's Law Deptt.
4. **In Case of Bank Guarantees submitted by Foreign Vendors-**
 - a. **From Nationalized/Public Sector / Private Sector/ Foreign Banks (BG issued by Branches in India)** can be accepted subject to the condition that the Bank Guarantee should be enforceable in the town/city or at nearest branch where the Unit is located i.e., Demand can be presented at the Branch located in the town/city or at nearest branch where the Unit is located.
 - b. **From Foreign Banks (wherein Foreign Vendors intend to provide BG from local branch of the Vendor country's Bank)**

b.1 In such cases, in the Tender Enquiry/ Contract itself, it may be clearly specified that Bank Guarantee issued by **any of the Consortium Banks only** will be accepted by BHEL. As such, Foreign Vendor needs to make necessary arrangements for issuance of Counter-Guarantee by Foreign Bank in favour of the Indian Bank's (BHEL's Consortium Bank) branch in India. It is advisable that all charges for issuance of Bank Guarantee/ counter-Guarantee should be borne by the Foreign Vendor. The tender stipulation should clearly specify these requirements.

b.2 In case, Foreign Vendors intend to provide BG from Overseas Branch of our Consortium Bank (e.g. if a BG is to be issued by SBI Frankfurt), the same is acceptable. However, the procedure at **sl.no. b.1** will required to be followed.

b.3 The BG issued may preferably be subject to Uniform Rules for Demand Guarantees (URDG) 758 (as amended from time to time). The BG Format provided to them should clearly specify the same.

ANNEXURE – 17**BANK GUARANTEE FOR PERFORMANCE SECURITY**

(On non-Judicial paper of appropriate value)

Bank Guarantee No:

Date:

To

NAME

& ADDRESSES OF THE BENEFICIARY

Dear Sirs,

In consideration of Bharat Heavy Electricals Limited (hereinafter referred to as the 'Employer' which expression shall unless repugnant to the context or meaning thereof, include its successors and permitted assigns) incorporated under the Companies Act, 1956 and having its registered office at _____¹ through its Unit at.....(name of the Unit) having awarded to (Name of the Vendor / Contractor / Supplier) with its registered office at _____² hereinafter referred to as the 'Vendor / Contractor / Supplier', which expression shall unless repugnant to the context or meaning thereof, include its successors and permitted assigns), a contract Ref No.....dated³ valued at Rs.....⁴ (Rupees -----) / FC.....(in words.....) for⁵ (hereinafter called the 'Contract') and the Vendor / Contractor / Supplier having agreed to provide a Contract Performance Bank Guarantee, equivalent to% (.... Percent) of the said value of the Contract to the Employer for the faithful performance of the Contract,

We,, (hereinafter referred to as the Bank), having registered/Head office at and inter alia a branch at being the Guarantor under this Guarantee, hereby, irrevocably and unconditionally undertake to forthwith and immediately pay to the Employer any sum or sums upto a maximum amount of Rs -----⁶ (Rupees -----) without any demur, immediately on first demand from the Employer and without any reservation, protest, and recourse and without the Employer needing to prove or demonstrate reasons for its such demand.

Any such demand made on the Bank shall be conclusive as regards the amount due and payable by the Bank under this guarantee. However, our liability under this guarantee shall be restricted to an amount not exceeding Rs. _____.

We undertake to pay to the Employer any money so demanded notwithstanding any dispute or disputes raised by the Vendor / Contractor / Supplier in any suit or proceeding pending before any Court or

Tribunal, Arbitrator or any other authority, our liability under this present being absolute and unequivocal.

The payment so made by us under this Guarantee shall be a valid discharge of our liability for payment thereunder and the Vendor / Contractor / Supplier shall have no claim against us for making such payment.

We thebank further agree that the guarantee herein contained shall remain in full force and effect during the period that would be taken for the performance of the said Contract/ satisfactory completion of the performance guarantee period as per the terms of the Contract and that it shall continue to be enforceable till all the dues of the Employer under or by virtue of the said Contract have been fully paid and its claims satisfied or discharged.

WeBANK further agree with the Employer that the Employer shall have the fullest liberty without our consent and without affecting in any manner our obligations hereunder to vary any of the terms and conditions of the said Contract or to extend time of performance by the said Vendor / Contractor / Supplier from time to time or to postpone for any time or from time to time any of the powers exercisable by the Employer against the said Vendor / Contractor / Supplier and to forbear or enforce any of the terms and conditions relating to the said Contract and we shall not be relieved from our liability by reason of any such variation, or extension being granted to the said Vendor / Contractor / Supplier or for any forbearance, act or omission on the part of the Employer or any indulgence by the Employer to the said Vendor / Contractor / Supplier or by any such matter or thing whatsoever which under the law relating to sureties would but for this provision have effect of so relieving us.

The Bank also agrees that the Employer at its option shall be entitled to enforce this Guarantee against the Bank as a principal debtor, in the first instance without proceeding against the Vendor / Contractor / Supplier and notwithstanding any security or other guarantee that the Employer may have in relation to the Vendor / Contractor / Supplier 's liabilities.

This Guarantee shall remain in force upto and including.....⁷ and shall be extended from time to time for such period as may be desired by Employer.

This Guarantee shall not be determined or affected by liquidation or winding up, dissolution or change of constitution or insolvency of the Vendor / Contractor / Supplier but shall in all respects and for all purposes be binding and operative until payment of all money payable to the Employer in terms thereof.

Unless a demand or claim under this guarantee is made on us in writing on or before the⁸ we shall be discharged from all liabilities under this guarantee thereafter.

This Bank Guarantee shall be governed, construed and interpreted in accordance with the laws of India.

Courts at shall alone have exclusive jurisdiction over any matter arising out of or in connection with this Bank Guarantee

We, BANK lastly undertake not to revoke this guarantee during its currency except with the previous consent of the Employer in writing.

Notwithstanding anything to the contrary contained hereinabove:

- a. The liability of the Bank under this Guarantee shall not exceed.....⁶
- b. This Guarantee shall be valid up to⁷
- c. Unless the Bank is served a written claim or demand on or before⁸ all rights under this guarantee shall be forfeited and the Bank shall be relieved and discharged from all liabilities under this guarantee irrespective of whether or not the original bank guarantee is returned to the Bank.

We, _____ Bank, have power to issue this Guarantee under law and the undersigned as a duly authorized person has full powers to sign this Guarantee on behalf of the Bank.

For and on behalf of
(Name of the Bank)

Dated.....

Place of Issue.....

¹ NAME AND ADDRESS OF EMPLOYER i.e., Bharat Heavy Electricals Limited

² NAME AND ADDRESS OF THE VENDOR /CONTRACTOR / SUPPLIER.

³ DETAILS ABOUT THE NOTICE OF AWARD/CONTRACT REFERENCE

⁴ CONTRACT VALUE

⁵ PROJECT/SUPPLY DETAILS

⁶ BG AMOUNT IN FIGURES AND WORDS

⁷ VALIDITY DATE

⁸ DATE OF EXPIRY OF CLAIM PERIOD

Note:

1. Units are advised that expiry of claim period may be kept 3-6 months after validity date. It may be ensured that the same is in line with the agreement/ contract entered with the Vendor.
2. The BG should be on Non-Judicial Stamp paper/e-stamp paper of appropriate value as per Stamp Act prevailing in the State(s) where the BG is submitted or is to be acted upon or the rate prevailing in the State where the BG was executed, whichever is higher. The Stamp Paper/e-stamp paper shall be purchased in the name of Vendor/Contractor/Supplier /Bank issuing the guarantee.
3. In line with the GCC, SCC or contractual terms, Unit may carry out minor modifications in the Standard BG Formats. If required, such modifications may be carried out after taking up appropriately with the Unit/Region's Law Deptt.
4. **In Case of Bank Guarantees submitted by Foreign Vendors-**
 - a. **From Nationalized/Public Sector / Private Sector/ Foreign Banks (BG issued by Branches in India)** can be accepted subject to the condition that the Bank Guarantee should be enforceable in the town/city or at nearest branch where the Unit is located i.e.

Demand can be presented at the Branch located in the town/city or at nearest branch where the Unit is located.

b. From Foreign Banks (wherein Foreign Vendors intend to provide BG from local branch of the Vendor country's Bank)

b.1 In such cases, in the Tender Enquiry/ Contract itself, it may be clearly specified that Bank Guarantee issued by **any of the Consortium Banks only** will be accepted by BHEL. As such, Foreign Vendor needs to make necessary arrangements for issuance of Counter-Guarantee by Foreign Bank in favour of the Indian Bank's (BHEL's Consortium Bank) branch in India. It is advisable that all charges for issuance of Bank Guarantee/ counter-Guarantee should be borne by the Foreign Vendor. The tender stipulation should clearly specify these requirements.

b.2 In case, Foreign Vendors intend to provide BG from Overseas Branch of our Consortium Bank (e.g. if a BG is to be issued by SBI Frankfurt), the same is acceptable. However, the procedure at **sl.no. b.1** will required to be followed.

b.3 The BG issued may preferably be subject to Uniform Rules for Demand Guarantees (URDG) 758 (as amended from time to time). The BG Format provided to them should clearly specify the same.

ANNEXURE – 18**LIST OF CONSORTIUM BANK**

| SI. No. | NAME OF THE BANK |
|----------------|---|
| 1 | State Bank of India |
| 2 | Canara Bank |
| 3 | IDBI Bank Limited |
| 4 | ICICI Bank Limited |
| 5 | HDFC Bank Limited |
| 6 | Axis Bank |
| 7 | IndusInd Bank Limited |
| 8 | Bank of Baroda |
| 9 | Exim Bank |
| 10 | Indian Bank |
| 11 | Punjab National Bank |
| 12 | Union Bank of India |
| 13 | Yes Bank Limited |
| 14 | RBL Bank Ltd. |
| 15 | Standard Chartered Bank |
| 16 | Indian Overseas Bank |
| 17 | Kotak Mahindra Bank Limited |
| 18 | Federal Bank Limited |
| 19 | Hongkong and Shanghai Banking Corporation Ltd |