



PRODUCT STANDARD

PULVERISERS

HYDERABAD

Product
STD no.

BA89153

Rev No. 00

Page 1 of 4

Complete set of wear resistant rubber lining system for Wet Ball Mill

1.0 APPLICATION: Limestone grinding Wet Ball Mill 52 TPH 4074 of Flue Gas Desulfurization unit.

2.0 TECHNICAL:

This specification governs the procurement of complete set of wear resistant rubber lining system (SBR based rubber) for Wet Ball Mill. Set of liner shall include shell liner, feed end head liners, discharge end head liners along with necessary hardware for fixing arrangement.

Lifter bars have to be fastened to the shell by means of clamp block (which slide into the grooves provided at the underside of the lifter bars), washers and nuts. The fastening system shall be leak-proof and designed to utilize rubber flexibility to the maximum & 6 mm thick rubber backing shall be provided along with standard adhesive.

Diameter of mill shell (ID) 4000 mm

Length of mill shell 7400 mm

Technical properties of Rubber compound shall be as indicated below:

Hardness : 62 (± 5) shore A

Tensile strength : 155 Kg/sq cm (minimum)

Elongation at break : 500-700%

Din abrasion loss : 80 mm³ (maximum)

Specific gravity : 1.12 (± 0.005)

Withstand temp. : below 80° C

pH of slurry : upto 11

Ball charge size 100 mm (maximum)

The mill dimensions are indicated in Annexure III. Lay out & pitching for fasteners of the liners shall be provided by the vendor. Two man-holes are provided at each end of the shell. Vendor shall supply suitable manhole doors lined with rubber liners such that the door can be removed without disturbing the other liners.



PRODUCT STANDARD

PULVERISERS

HYDERABAD

Product
STD no.

BA89153

Rev No. 00

Page 2 of 4

3.0 GUARANTEES:

- 3.1 The minimum guaranteed wear life shall be 8000 hours (without repair or reversal of liners) for the lime stone & water as specified in Annexure-I & II.
- 3.2 The supplier shall give back to back guarantee for wear life of liners as per terms and conditions of applicable contract.
- 3.3 Failure due to manufacturing defects (generally leading to breakage/catastrophic failure of liners elements) shall be replaced and installed immediately.

4. QUANTITY REQUIRED PER MILL

- 1) Complete set of liners for shell (with inspection door), Discharge Head, delivery head as per the drawing in Annexure III.
- 2) 6 mm back up rubber material with adhesive required for the same
- 3) Hardware for fastening of liners.

5. MANUFACTURING PROCESS AND QUALITY PLAN:

- a. A detailed manufacturing process (along with the process control parameters) and manufacturing and test facilities data shall be submitted for review by BHEL.
- b. Material used for the manufacture of the liners shall be specified along with the technical details. The details of the patented portion of the technology need not be provided, however the generic name of the proven patented technology along with the broad details shall be provided.
- c. A Quality plan with stage wise inspection and acceptance criteria shall be submitted for approval by BHEL and/or customer.
- d. The PROCESS CONTROL shall consist of 100% testing the quality of mixed compound in a Rheometer to ensure that each batch is consistent with the proper proportion of each ingredient of the compound so as to result in a correct and standard quality of product to give desired results in installations.



PRODUCT STANDARD
PULVERISERS
HYDERABAD

Product
STD no.

BA89153

Rev No. 00

Page 3 of 4

COPYRIGHT AND CONFIDENTIAL
The information on this document is the property of BHARAT HEAVY ELECTRICALS LIMITED, It must not be used directly or indirectly in any way detrimental to the interest of the company.

6. INSPECTION:

- a. The inspection of liners will be as per the approved quality plan
- b. Tests and inspection are to be conducted in the presence of BHEL/ customer representatives as per approved Quality plan. The representatives shall have free access at all times while the work on the contract is being performed. The supplier shall offer all the tools and tackles required for inspection to the inspection agency.

7. TEST CERTIFICATE:

All the liners shall be identified with a serial number. Supplier shall supply 3 copies of Test certificates with following information for each set:

1. BHEL order number.
2. Supplier's reference and name.
3. Batch Heat No.
4. Results of Hardness Test and all other tests or any other tests as per approved QAP.
5. Drawing no., Material Code.
6. Consignment/ Identification no.

8. PACKING:

Liners shall be suitably packed in metallic boxes set wise to prevent damage during transit. Metallic surfaces shall be properly protected with suitable anti-corrosive compound. Each package shall be legibly marked with following information.

1. BHEL Order No.
2. Consignment/ Identification No.
3. Set No.
4. Drawing no., Material Code
5. Weight in Kg
6. Suppliers Name

9. SUPERVISION & SERVICES:

Personnel for supervision for Erection and commissioning shall be deputed within a period of one week from the notice given by BHEL.



PRODUCT STANDARD

PULVERISERS

HYDERABAD

Product
STD no.

BA89153

Rev No. 00

Page 4 of 4

TABLE FOR MATERIAL CODE

Var No.	Mill Type	Item Description	Material Code
01	4074	WBM LINERS 52 TPH WBM	BA9789153007

List of Annexures

Annexure No.	Description	Remarks
I	LIMESTONE ANALYSIS /	
II	WATER ANALYSIS	
III	SHELL ASSY	
IV	Cheek with trunnion-DE	06221500002-S00-R00
V	Cheek with trunnion-NDE	06221500007-S00-R00
VI	Half Shell-DE	06221500046-S00-R00
VII	Half Shell-NDE	06221500047-S00-R00

RECORD OF REVISION

REV. NO	DATE	REVISION DETAILS	REVISED	APPROVED

	PROJECT	TSGENCO YTPS 5X800 MW FGD
	FGD	WET LIMESTONE BASED FGD SYSTEM
	PARAMETERS	SELECTION PARAMETERS FOR WET BALL MILL



1.0 BALL MILL & FEEDER SELECTION DATA

S.NO	DESCRIPTION	DATA
1.0	WET BALL MILL (WBM)	
1.1	Number of wet ball mills	03 Nos (2W + 1S)
1.2	Rated capacity of wet ball mill, kg/h	52,000.
2.0	FEEDER	
2.1	Type of feeder	Gravimetric
2.2	Number of feeders	3 Nos (2W + 1S)
2.3	Capacity of feeder, kg/h	57,200

2.0 LIMESTONE ANALYSIS/CHARACTERISTICS

The following limestone property to be used designing Limestone grinding system

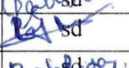
Sl.No	Absorbent Composition	Unit	Limestone	Note
1.	Dolomite	wt%-d	Not Detectable	
2.	CaO	wt%-d	47-50	
	In CaCO ₃	wt%-d	83.88 to 89.00	
3.	MgO	wt%-d	0.9-3.8	
4.	Inert			
	Cl ₂	wt%-d	<0.015	
	Al ₂ O ₃	wt%-d	1.19-2.1	
	Si ₂ O ₃	wt%-d	2.1-4.5	
	Fe ₂ O ₃	wt%-d	0.45-1.0	
	TiO ₂	wt%-d	<0.02	
	Na ₂ O	wt%-d	<0.16	
	K ₂ O	wt%-d	<0.01	
	P ₂ O ₅	wt%-d	Traces	
	LOI	wt%-d	38.0-41.3	
	Total Sulphur	wt%-d	<0.1	
	Mn ₂ O ₃	wt%-d	<0.12	
5.	Density	kg/m ³	1400	For Volumetric Calculation
		kg/m ³	1700	For Torque & Drive Calculation
		kg/m ³	2200	For structural load calculation
6.	Granule Size	mm	≤ 25 (100 %)	At limestone silo near to wet ball mill
7.	Bond Index	Kwh/Mt	14.33	

Project: TSGENCO YTPS 5X800 MW							
Cont. No. :		Rev 00		Rev 01		Rev 02	
R4R8,R4R9,R4S0,R4S1,R4S2		Sign	Date	Sign	Date	Sign	Date
Engineer	Kabilash		22.06.21				
Reviewer	P.Raju		22.06.21				
Approver	Naveen		22.06.21				

	PROJECT	TSGENCO YTPS 5X800 MW FGD
	FGD	WET LIMESTONE BASED FGD SYSTEM
	PARAMETERS	SELECTION PARAMETERS FOR WET BALL MILL

3.0 WATER ANALYSIS

The following water to be used during the grinding process of limestone in Lime stone grinding system (LGS)

Sr. No.	Parameter	Unit	Clarified Water Analysis
1.	Calcium as CaCO ₃	ppm	121.9
2.	Magnesium as CaCO ₃	Ppm	74.1
3.	Sodium as CaCO ₃	Ppm	184.4
4.	Potassium as CaCO ₃	Ppm	1.1
5.	Iron in Soln	ppm	Nil
6.	Total Cations as CaCO ₃	ppm	381.5
7.	Bicarbonate as CaCO ₃	Ppm	134.8
8.	Sulphate as CaCO ₃	Ppm	80.9
9.	Chloride as CaCO ₃	Ppm	161.0
10.	Nitrate as CaCO ₃	Ppm	3.5
11.	Total Anions as CaCO ₃	Ppm	381.5
12.	Reactive Silica as SiO ₂	Ppm	14.1
13.	Colloidal Silica as SiO ₂	Ppm	Nil
14.	Total Silica as SiO ₂	Ppm	14.1
15.	Nitrites	Ppm	Nil
16.	Total Hardness as CaCO ₃	Ppm	196
17.	Total Suspended Solids		15
18.	pH Value at 25 °C	-	7.0- 8.2
19.	Turbidity	NTU	15
20.	Fluoride	ppm	1.3

The following chemical dosage have been considered on the Raw water analysis for Pretreatment Plant & above clarified water analysis has been arrived.

Chlorine dosing : 5 ppm
Lime dosing : 20 ppm

Alum dosing : 50 ppm
Poly electrolyte (PE) : 1ppm

2 | Page

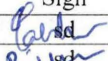
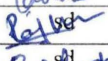
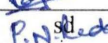
Project: TSGENCO YTPS 5X800 MW							
Cont. No. :		Rev 00		Rev 01		Rev 02	
R4R8,R4R9,R4S0,R4S1,R4S2		Sign	Date	Sign	Date	Sign	Date
Engineer	Kabilash		22.06.21				
Reviewer	P.Raju		22.06.21				
Approver	Naveen		22.06.21				



PROJECT	TSGENCO YTPS 5X800 MW FGD
FGD	WET LIMESTONE BASED FGD SYSTEM
PARAMETERS	SELECTION PARAMETERS FOR WET BALL MILL



4.0 PROCESS DATA (All the blank cells to be filled by the vendor)

Stream no	<1>	<2>	<3>	<4>	<5>	<6>	<7>
Fluid	Lump limestone	Limestone ball mill overflow	Hydro cyclone feed	Hydro cyclone underflow return	Process water to ball mill	Process water to mill tank	Limestone product slurry
Total flow kg/h	52,000						
Total flow m ³ /h							
Temp °C	45				27	27	
Solid wt.%	100				0	0	30

5.0 SCHEDULE OF GUARANTEES

Sl. No	Description	Data
1.	Rated capacity of Wet Ball Mill (WBM)	TPH : 52.0
2.	Rated capacity of gravimetric feeder	TPH : 57.2
3.	Power consumption at rated capacity #	kW : Bidder to Provide
4.	Noise level at a distance of 1.0 meter from the equipment at site and 1.5 m above operating floor	dB(A) : ≤ 90 dbA(for ball mill) ≤ 85 dbA(for other equipments)
5.	Maximum vibration (peak to peak amplitude at site)	microns : Bidder to Provide
6.	Equipment Availability in % (avg. target 98%) Continuous for 120 days	: Bidder to Provide
7.	Life of WBM wear parts	Hours : ≥8000 hours operation
8.	Limestone output fineness at rated capacity	: ≥ 90% through 325mesh.
9.	Guaranteed ball consumption	: Bidder to provide (<700 g per ton of ground limestone)
10.	In the event PG test is unsuccessful, bidder shall take necessary remedial action at his cost & PG test shall be repeated	: Bidder to Confirm

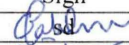
3 | Page

Project: TSGENCO YTPS 5X800 MW							
Cont. No. : R4R8,R4R9,R4S0,R4S1,R4S2		Rev 00		Rev 01		Rev 02	
		Sign	Date	Sign	Date	Sign	Date
Engineer	Kabilash		22.06.21				
Reviewer	P.Raju		22.06.21				
Approver	Naveen		22.06.21				



PROJECT	TSGENCO YTPS 5X800 MW FGD
FGD	WET LIMESTONE BASED FGD SYSTEM
PARAMETERS	SELECTION PARAMETERS FOR WET BALL MILL

General Note:

- POWER CONSUMPTION to be guaranteed corresponding to rated capacity of 52.0 TPH of Ball Mill Capacity shall not exceed 1750 KW for One (01) No of working Mill system & its auxiliaries and 3500 KW for Two (02) No's of working mill system & its auxiliaries.
The following equipments are considered for calculating power consumption:
 - Gravimetric feeder
 - Wet ball mill
 - HP trunnion Lube oil pump
 - LP trunnion Lube oil pump
 - Oil reservoir heater
 - Mill circuit tank agitator
 - Mill circuit tank pump
- Refer YTPS Design memorandum for MOC and other technical details pertaining to wet ball mill and its accessories.
- Instruments and valves to be provided as per the approved P&ID.
- Wet ball mill and its accessories related P&ID will be will be included in input Transmittal after obtaining the approval from TSGENCO customer.
- Mandatory Spares to be supplied as per contact requirement. (As per the recent MOM, there is a change in the scope of mandatory spares. Hence, Request HPEP to obtain latest mandatory spares list from PSM).

Project: TSGENCO YTPS 5X800 MW							
Cont. No. :		Rev 00		Rev 01		Rev 02	
R4R8,R4R9,R4S0,R4S1,R4S2		Sign	Date	Sign	Date	Sign	Date
Engineer	Kabilash		22.06.21				
Reviewer	P.Raju		22.06.21				
Approver	Naveen		22.06.21				

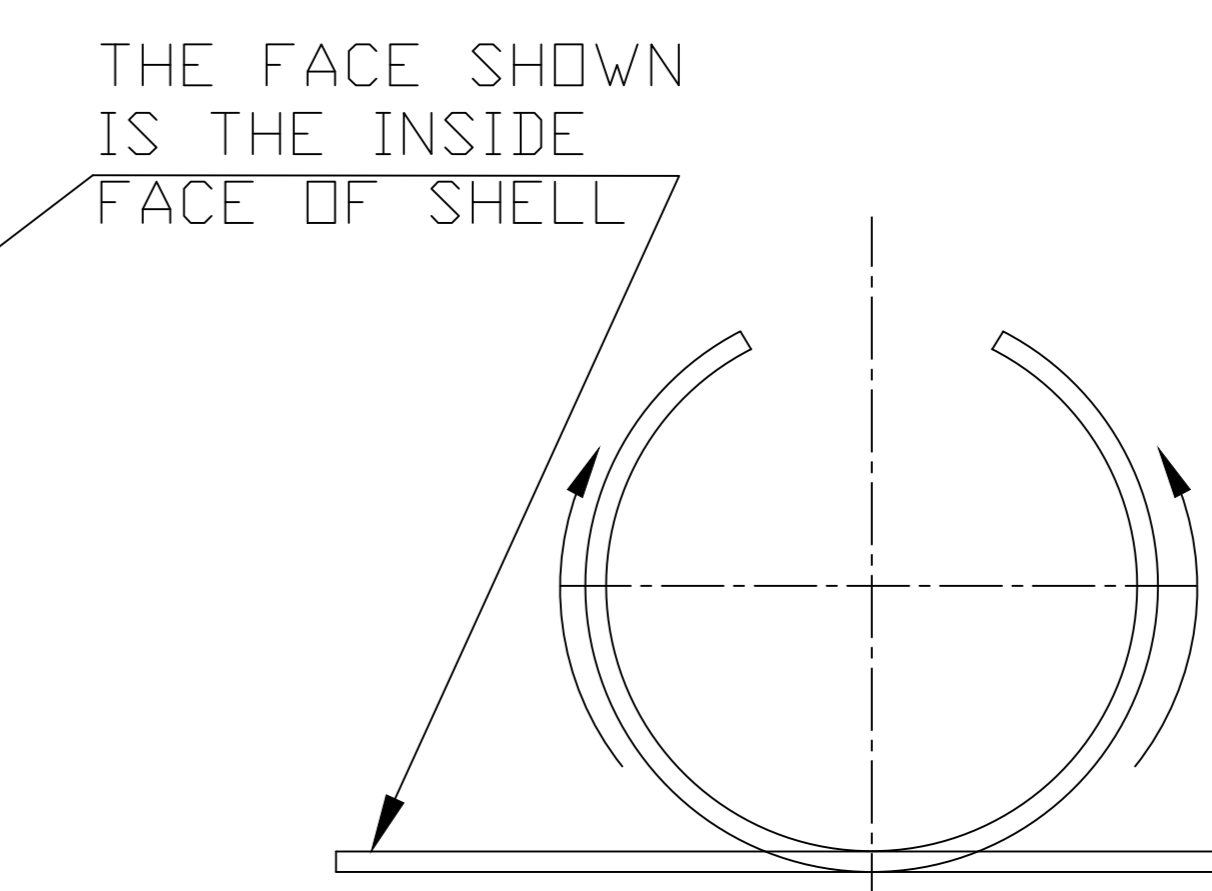
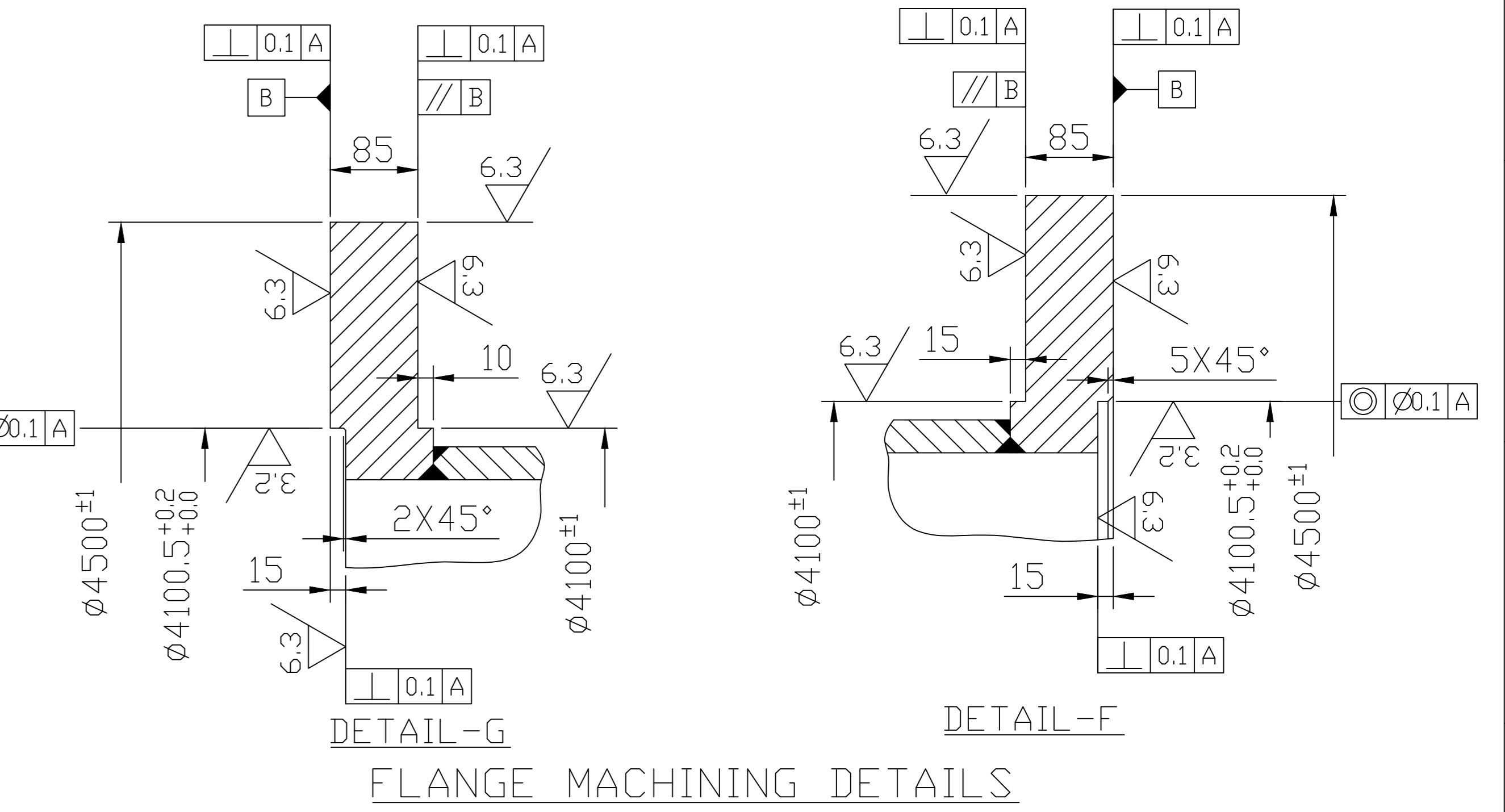
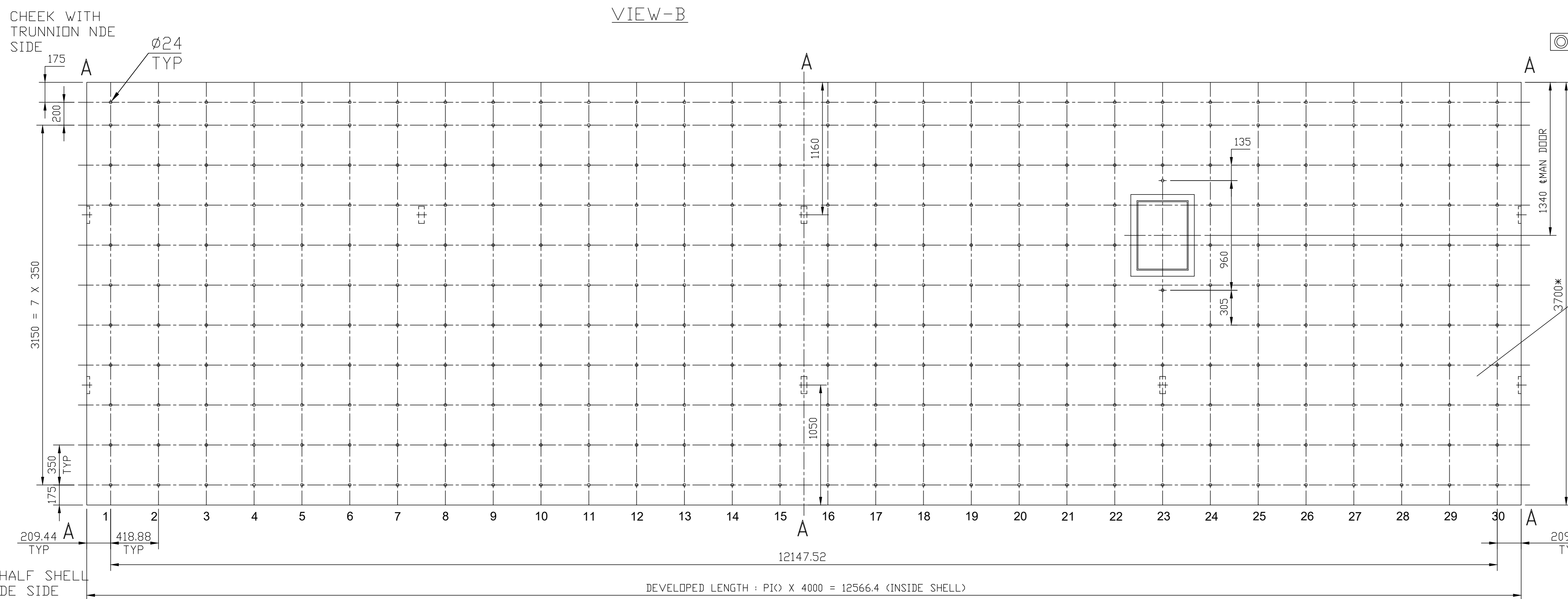
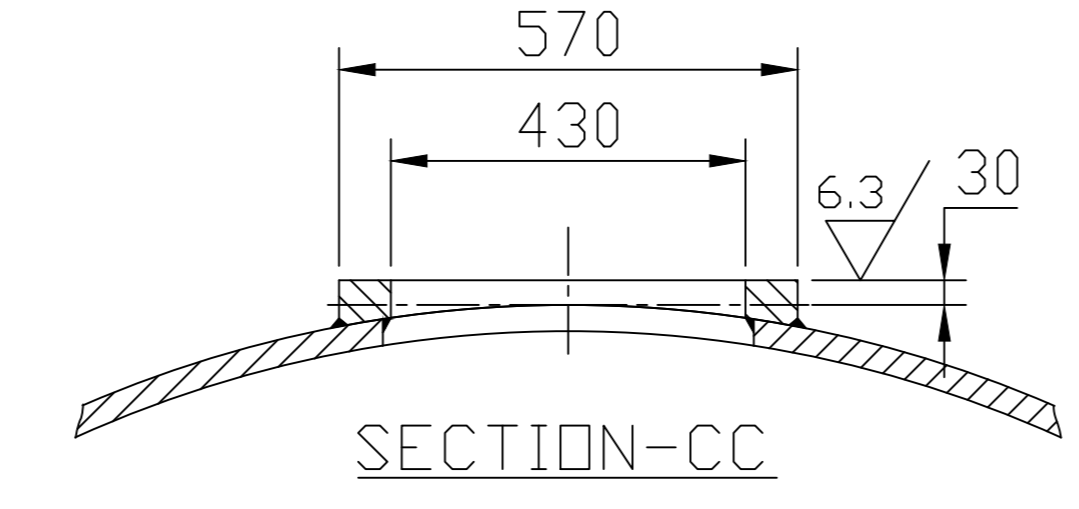
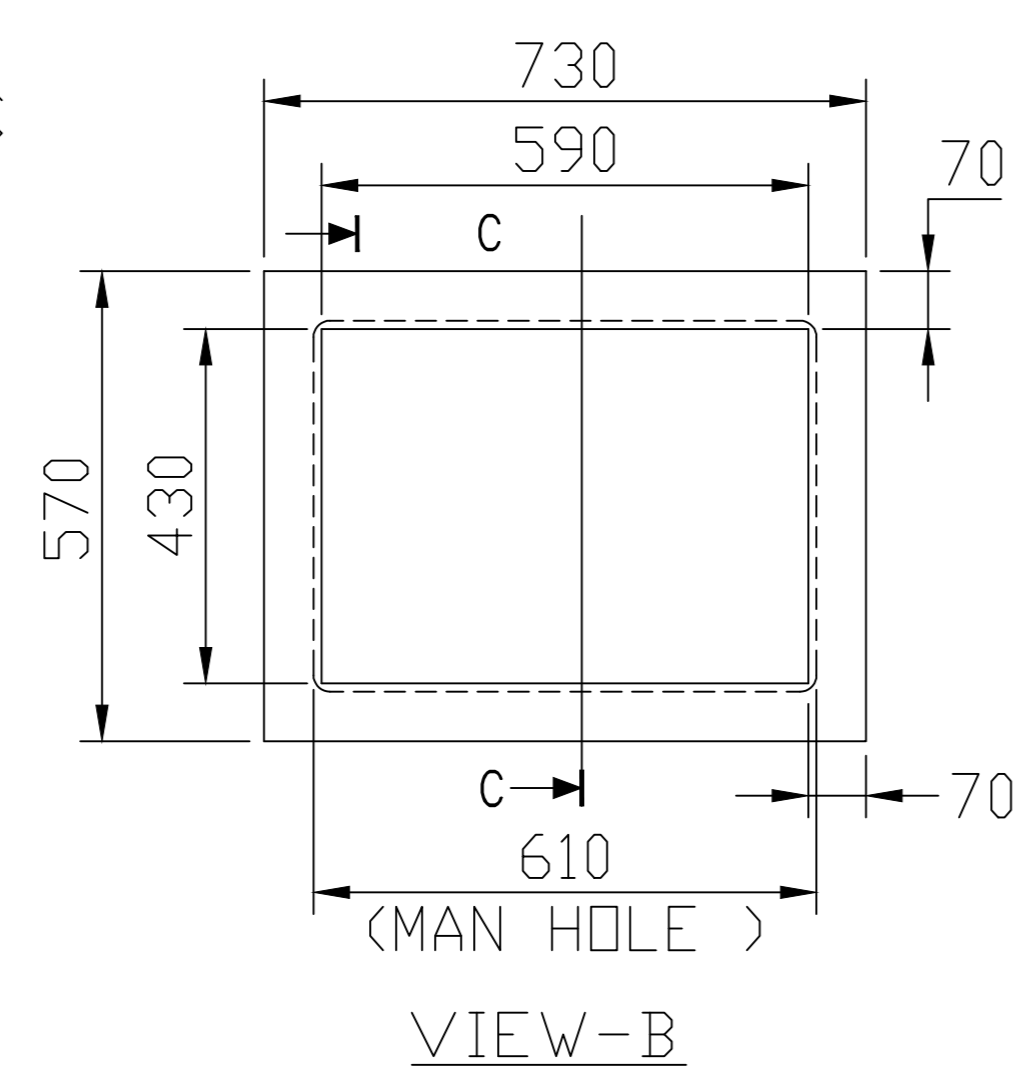
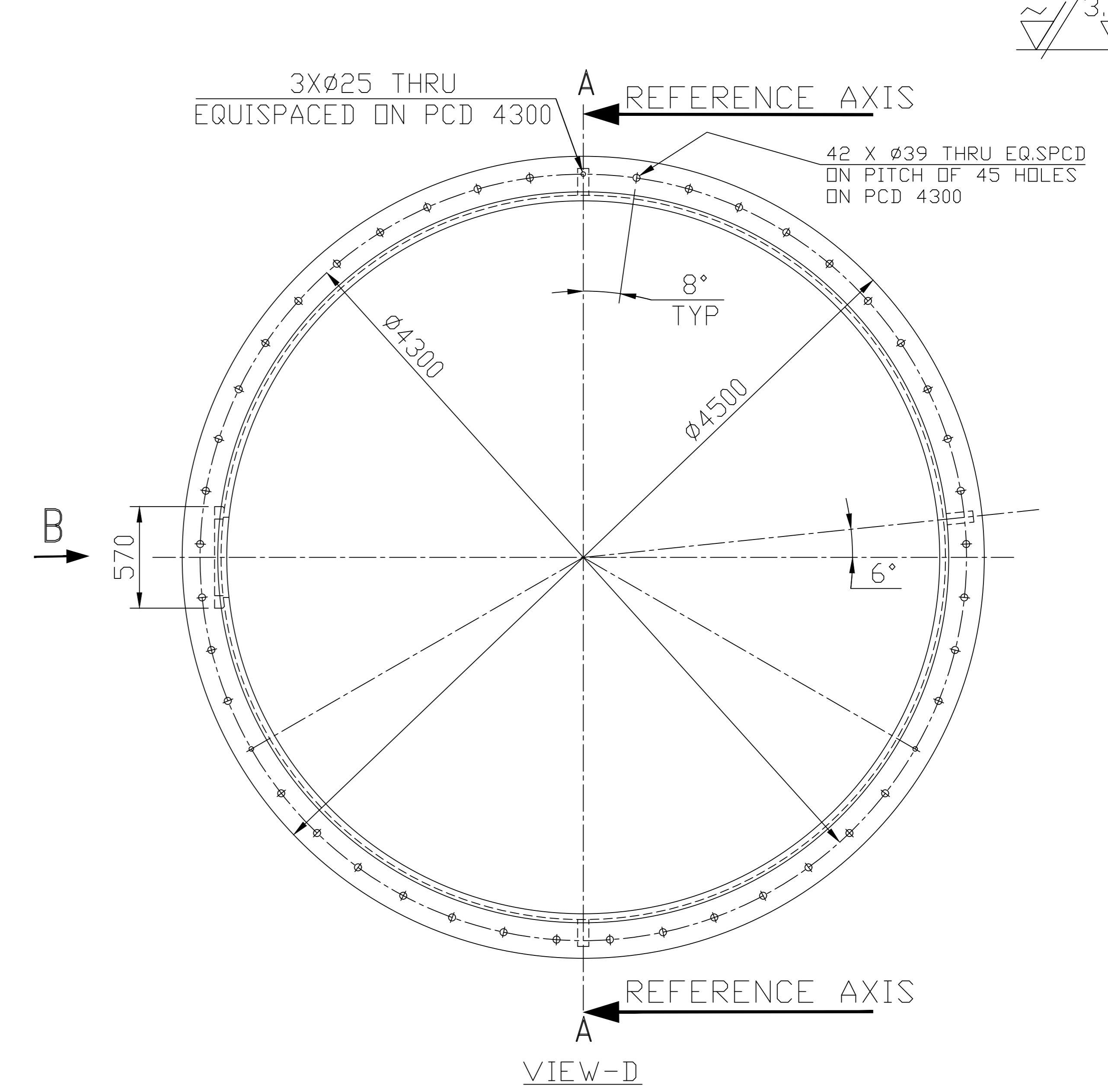
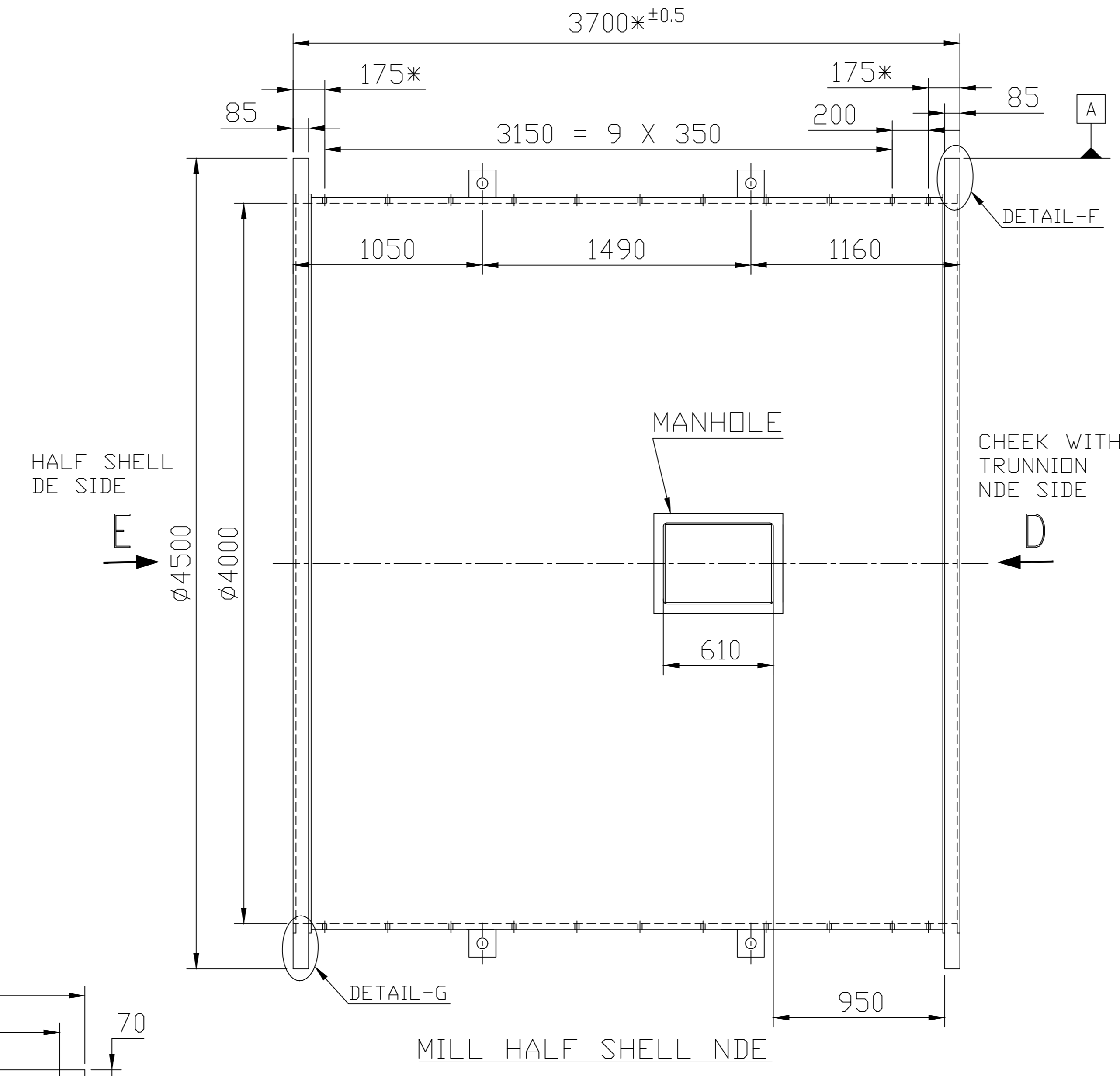
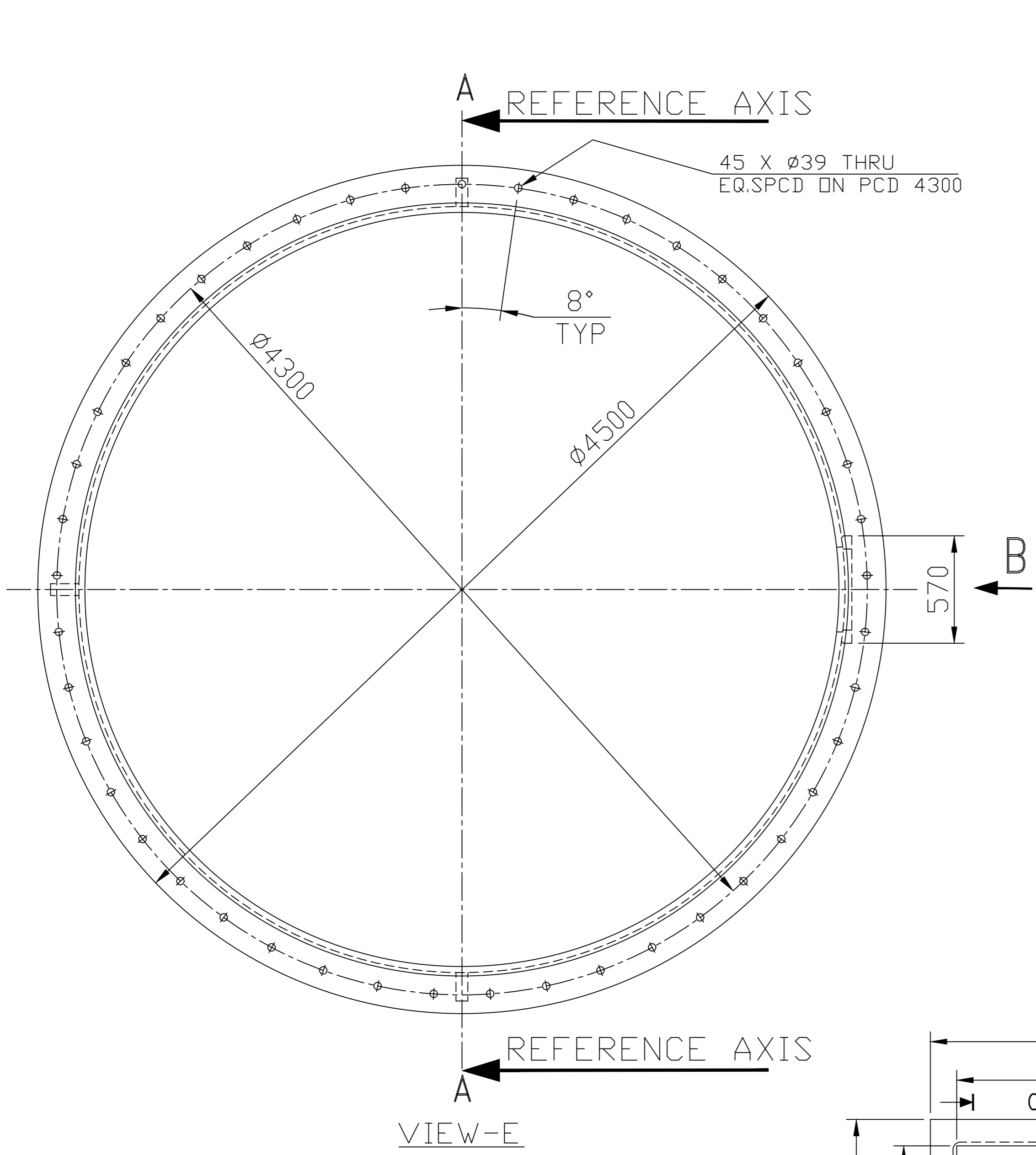

- NOTES:
1. DRILL THE LINER HOLES (Ø24 MM) AND HOLES ON SHELL FLANGES (Ø 25 AND Ø39) WITH REFERENCE TO A-A AXIS.THE POSITIONING DEVIATION OF LINER HOLES MUST NOT EXCEED ±1 MM.
 2. ALL HOLES SHALL BE CHAMFERED BY 1MM AT 45° ON OUTSIDE OF SHELL.
 3. CRITICAL DIMENSIONS ARE IDENTIFIED WITH '*'.
 4. INSPECTION AS PER APPROVED QUALITY PLAN.

01	MILL SHELL FAB WITH LIFTING LUGS	1-62-215-00020			18476	01
ITEM NO.	DESCRIPTION	DRAWING NO.	VAR. NO.	RAW MATERIAL SIZE OR CASTING DRG. NO. OR FORGING DRG. NO.	MATERIAL CODE	NET WT. GROSS WT. QUANTITY

NON-CAST PARTS FABRICATED AND/OR MACHINED. ALL DIMENSIONS ARE IN MILLIMETERS. TOLERANCES UNLESS OTHERWISE NOTED: XX ±0.40; X & XX ±1.5 FOR DIM 0-610 MM; X & XX ±0.8 FOR DIM 610-2440 MM; X & XX ±0.3 FOR DIM OVER 2440 MM. ANGULAR: ±0°30'. DRILLED HOLES: Ø 0-25MM ±0.25/-0.05 OVER 25 MM ±0.50/-0.05. SURFACE TEXTURE: ROUGHNESS AVERAGE-Ra 125 MICROMETERS. THIS DRAWING IS IN ACCORDANCE WITH ISQ 1101 UNLESS OTHERWISE SPECIFIED. THE THREAD PITCH IS STANDARD COARSE.

TYPE OF PRODUCT: WET BALL MILLS
NAME OF CUSTOMER/PROJECT: BHARAT HEAVY ELECTRICALS LIMITED HYDERABAD

DRN	NAME	STGN.	DATE	NO OF VAR.
	SHARIFF		26.07.22	
CHD	K.PAVAN		26.07.22	
APPD	AMAN		26.07.22	

SCALE: 1:1
WEIGHT (KG): 18476
REF. TO ASSY DRG.: 0-62-215-00047
DRAWING NO.: 0-62-215-00047
REV.: 00
SHEET NO.: 16 OF SHEETS

THE INFORMATION ON THIS DOCUMENT IS THE PROPERTY OF BHARAT HEAVY ELECTRICALS LIMITED. IT MUST NOT BE USED DIRECTLY OR INDIRECTLY IN ANY WAY DETRIMENTAL TO THE INTEREST OF THE COMPANY.