



PRODUCT STANDARD

PULVERISERS

HYDERABAD

Product
STD no.

BA89123

Rev No. 01

Page 1 of 4

Complete set of wear resistant rubber lining system for Wet Ball Mill

1.0 APPLICATION: Limestone grinding Wet Ball Mills 17.15 TPH 2958 of Flue Gas Desulfurization unit.

2.0 TECHNICAL:

This specification governs the procurement of complete set of wear resistant rubber lining system (SBR based rubber) for Wet Ball Mill. Set of liner shall include shell liner, feed end head liners, discharge end head liners along with necessary hardware for fixing arrangement.

Lifter bars have to be fastened to the shell by means of clamp block (which slide into the grooves provided at the underside of the lifter bars), washers and nuts. The fastening system shall be leak-proof and designed to utilize rubber flexibility to the maximum & 6 mm thick rubber backing shall be provided along with standard adhesive.

Diameter of mill shell (ID) 2900 mm

Length of mill shell 5800 mm

Technical properties of Rubber compound shall be as indicated below:

Hardness : 62 (± 5) shore A

Tensile strength : 155 Kg/sq cm (minimum)

Elongation at break : 500-700%

Din abrasion loss : 80 mm³ (maximum)

Specific gravity : 1.12 (± 0.005)

Withstand temp. : below 80° C

pH of slurry : upto 11

Ball charge size 100 mm (maximum)

The mill dimensions are indicated in Annexure III, IV, V & VI. Lay out & pitching for fasteners of the liners shall be provided by the vendor. Two man-holes are provided at each end of the shell. Vendor shall supply suitable manhole doors lined with rubber liners such that the door can be removed without disturbing the other liners.



PRODUCT STANDARD

PULVERISERS

HYDERABAD

Product
STD no.

BA89123

Rev No. 01

Page 2 of 4

3.0 GUARANTEES:

- 3.1 The minimum guaranteed wear life shall be 8000 hours (without repair or reversal of liners) for the lime stone & water as specified in Annexure-I & II.
- 3.2 The supplier shall give back to back guarantee for wear life of liners as per terms and conditions of applicable contract.
- 3.3 Failure due to manufacturing defects (generally leading to breakage/catastrophic failure of liners elements) shall be replaced and installed immediately.

4. QUANTITY REQUIRED PER MILL

- 1) Complete set of liners for shell (with inspection door), Discharge Head, delivery head as per the drawing in Annexure III, IV, V & VI.
- 2) 6 mm back up rubber material with adhesive required for the same
- 3) Hardware for fastening of liners.

5. MANUFACTURING PROCESS AND QUALITY PLAN:

- a. A detailed manufacturing process (along with the process control parameters) and manufacturing and test facilities data shall be submitted for review by BHEL.
- b. Material used for the manufacture of the liners shall be specified along with the technical details. The details of the patented portion of the technology need not be provided, however the generic name of the proven patented technology along with the broad details shall be provided.
- c. A Quality plan with stage wise inspection and acceptance criteria shall be submitted for approval by BHEL and/or customer.
- d. The PROCESS CONTROL shall consist of 100% testing the quality of mixed compound in a Rheometer to ensure that each batch is consistent with the proper proportion of each ingredient of the compound so as to result in a correct and standard quality of product to give desired results in installations.



PRODUCT STANDARD

PULVERISERS

HYDERABAD

Product
STD no.

BA89123

Rev No. 01

Page 3 of 4

COPYRIGHT AND CONFIDENTIAL
 The information on this document is the property of BHARAT HEAVY ELECTRICALS LIMITED, It must not be used directly or indirectly in any way detrimental to the interest of the company.

6. INSPECTION:

- a. The inspection of liners will be as per the approved quality plan
- b. Tests and inspection are to be conducted in the presence of BHEL/ customer representatives as per approved Quality plan. The representatives shall have free access at all times while the work on the contract is being performed. The supplier shall offer all the tools and tackles required for inspection to the inspection agency.

7. TEST CERTIFICATE:

All the liners shall be identified with a serial number. Supplier shall supply 3 copies of Test certificates with following information for each set:

1. BHEL order number.
2. Supplier's reference and name.
3. Batch Heat No.
4. Results of Hardness Test and all other tests or any other tests as per approved QAP.
5. Drawing no., Material Code.
6. Consignment/ Identification no.

8. PACKING:

Liners shall be suitably packed in metallic boxes set wise to prevent damage during transit. Metallic surfaces shall be properly protected with suitable anti-corrosive compound. Each package shall be legibly marked with following information.

1. BHEL Order No.
2. Consignment/ Identification No.
3. Set No.
4. Drawing no., Material Code
5. Weight in Kg
6. Suppliers Name

9. SUPERVISION & SERVICES:

Personnel for supervision for Erection and commissioning shall be deputed within a period of one week from the notice given by BHEL.



PRODUCT STANDARD

PULVERISERS

HYDERABAD

Product
STD no.

BA89123

Rev No. 01

Page 4 of 4

TABLE FOR MATERIAL CODE

Var No.	Mill Type	Item Description	Material Code
01	2958	Liners of Wet Ball Mill 17.15 TPH	BA9789123000

List of Annexures

Annexure No.	Description	Remarks
I	LIMESTONE ANALYSIS /	
II	WATER ANALYSIS	
III	SHELL ASSY	16221500019-00
IV	CHEEK DE	06221500021-00
V	CHEEK NDE	06221500022-00
VI	MILL HALF SHELL MACHINING-DE	06221500038-00
VII	MILL HALF SHELL MACHINING-NDE	06221500039-00

RECORD OF REVISION

REV. NO	DATE	REVISION DETAILS	REVISED	APPROVED
01	27.09.2022	Granule size of limestone fed to mill changed to 25 mm from 250 mm in Annexure - 1 lime stone properties	MANIVAS	AMAN



DOCUMENT TITLE:
DESIGN MEMORANDUM FOR FGD
1 X 800 MW KOTHAGUDEM TPS

BHEL DOCUMENT NO.: 04-FW-000-00525
 DEPARTMENT: FGD ENGINEERING GROUP
 REV. NO. 04 DATE: 23.01.2021
 Page: 18 of 26

3.3. LIMESTONE CHARACTERISTICS CONSIDERED FOR FGD DESIGN:

CHEMICAL ANALYSIS (% BY MASS)			
Sl. No	Description	unit	Values
1.	CaO	%	>= 51.0
2.	MgO	%	0.9 – 3.8
3.	Fe ₂ O ₃	%	0.45 - 1.0
4.	Al ₂ O ₃	%	1.19 – 2.1
5.	Si ₂ O ₃	%	2.1 – 4.5
6.	Mn ₂ O ₃	%	< 0.12
7.	P ₂ O ₅	%	Traces
8.	Cl ₂	%	< 0.015
9.	Na ₂ O	%	< 0.16
10.	K ₂ O	%	< 0.01
11.	TiO ₂	%	< 0.02
12.	Total Sulphur	%	< 0.1
13.	LOI		38 – 41.3
PHYSICAL PROPERTIES			
14.	Bond Index	KWh/Metric ton	14.33
15.	Granule size		Medium (25 mm)
16.	Bulk density		
	a. Volume	Kg/m ³	1400
	b. Torque and drive calculation	Kg/m ³	1700
	c. Structural load calculation	Kg/m ³	2200

Note: BHEL considered CaO % in limestone as 47.0 % for FGD design point and 50 % for FGD guarantee point (CaCO₃ of 89 %), BHEL confirms that FGD systems for Kothagudem will work satisfactorily in terms of meeting outlet emission of SO₂ even if CaO % of Limestone as 45.9%.



DOCUMENT TITLE:

DESIGN MEMORANDUM FOR FGD**1 X 800 MW KOTHAGUDEM TPS**

BHEL DOCUMENT NO.: 04-FW-000-00525

DEPARTMENT: FGD ENGINEERING GROUP

REV. NO. 04

DATE: 23.01.2021

Page: 19 of 26

3.4. WATER PROPERTIES CONSIDERED FOR FGD DESIGN:

Sl. No	Constituents	as	mg per litre
1.	Calcium	CaCO ₃	141.5
2.	Magnesium	CaCO ₃	45.0
3.	Sodium & Potassium	CaCO ₃	25.0
4.	Bi-Carbonates	CaCO ₃	117.5
5.	Chloride	CaCO ₃	27
6.	Sulphate	CaCO ₃	67
7.	Carbonate	CaCO ₃	0
8.	Silica	SiO ₂	10
9.	Iron	Fe	0.5
10.	pH value	-	7.8
11.	Turbidity	NTU	<15
12.	TDS		<500

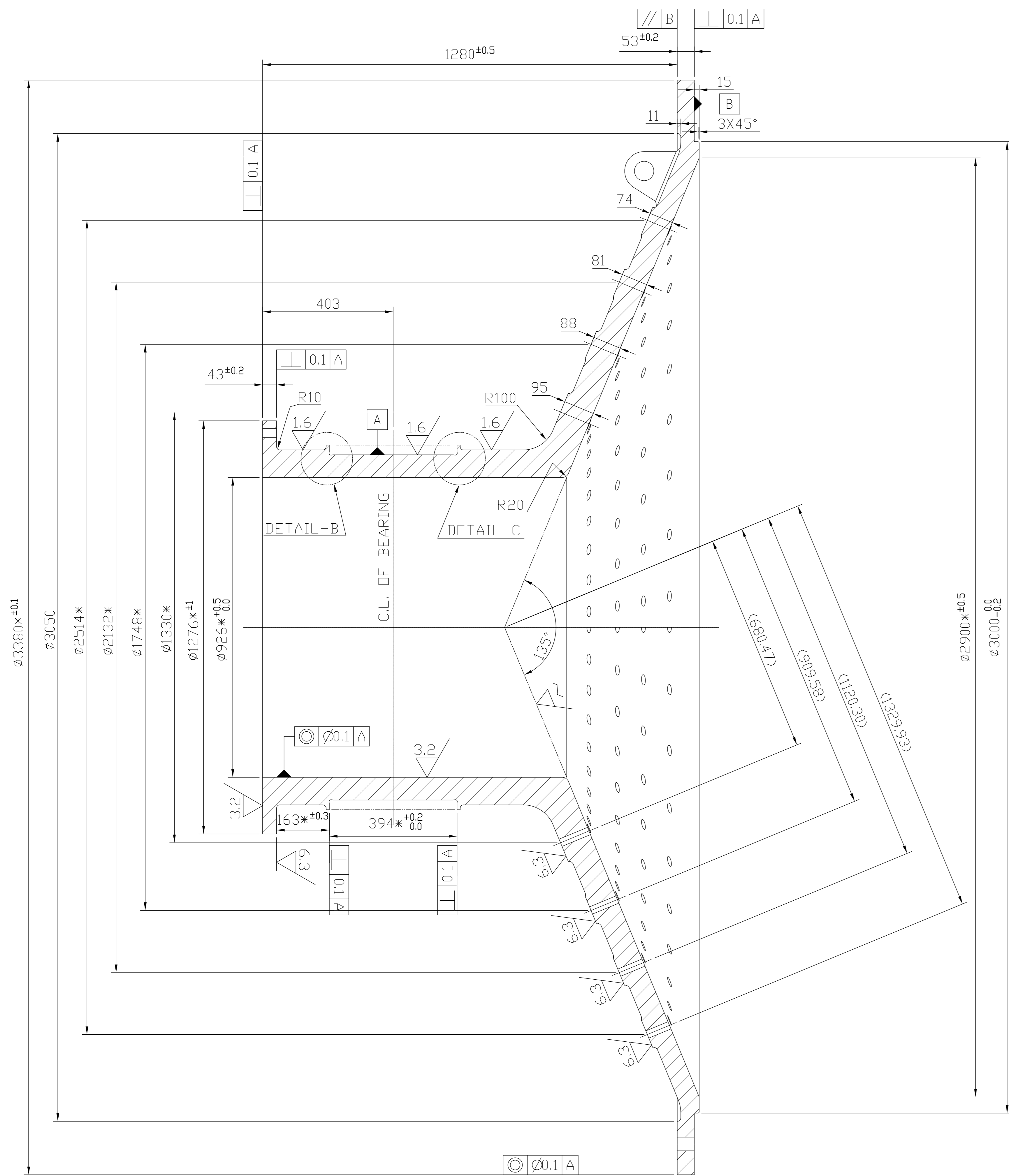

SECTION A-A

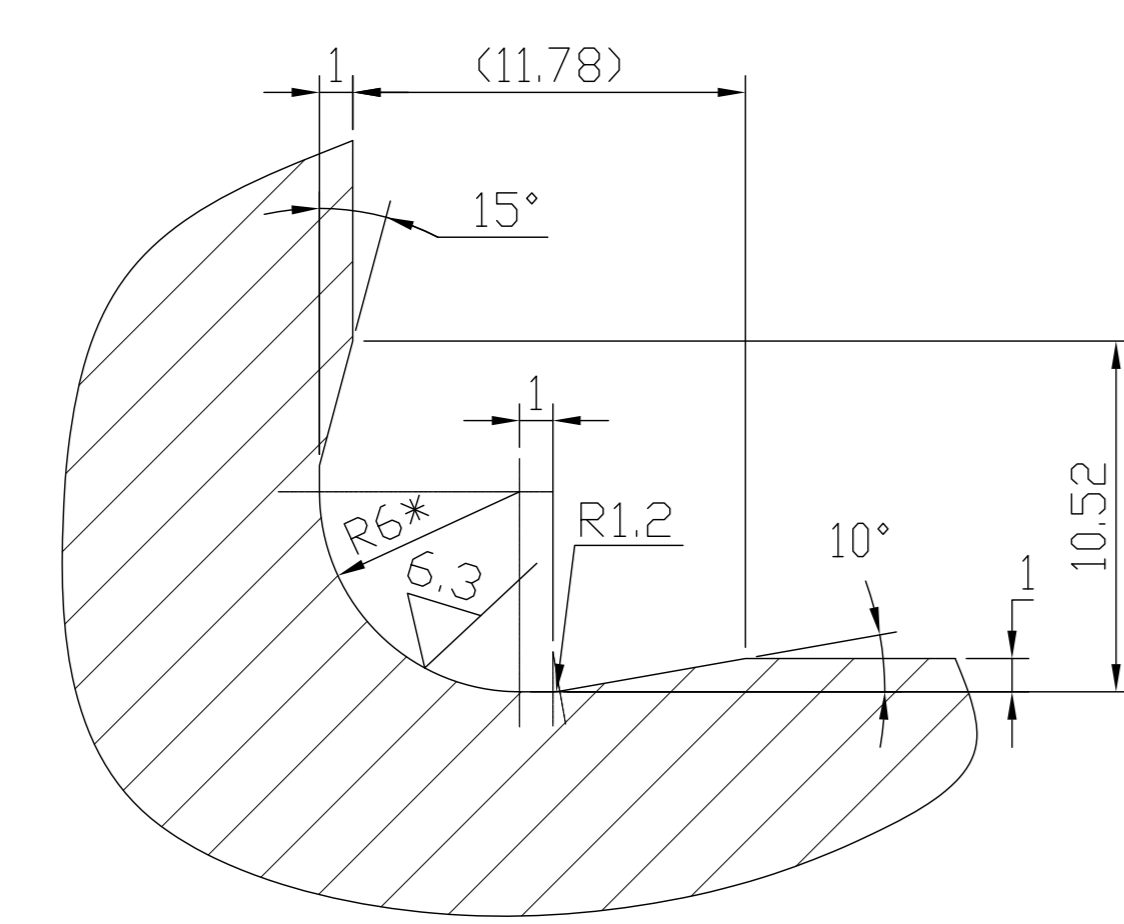

DETAIL-D
2 PLACES (TYP)

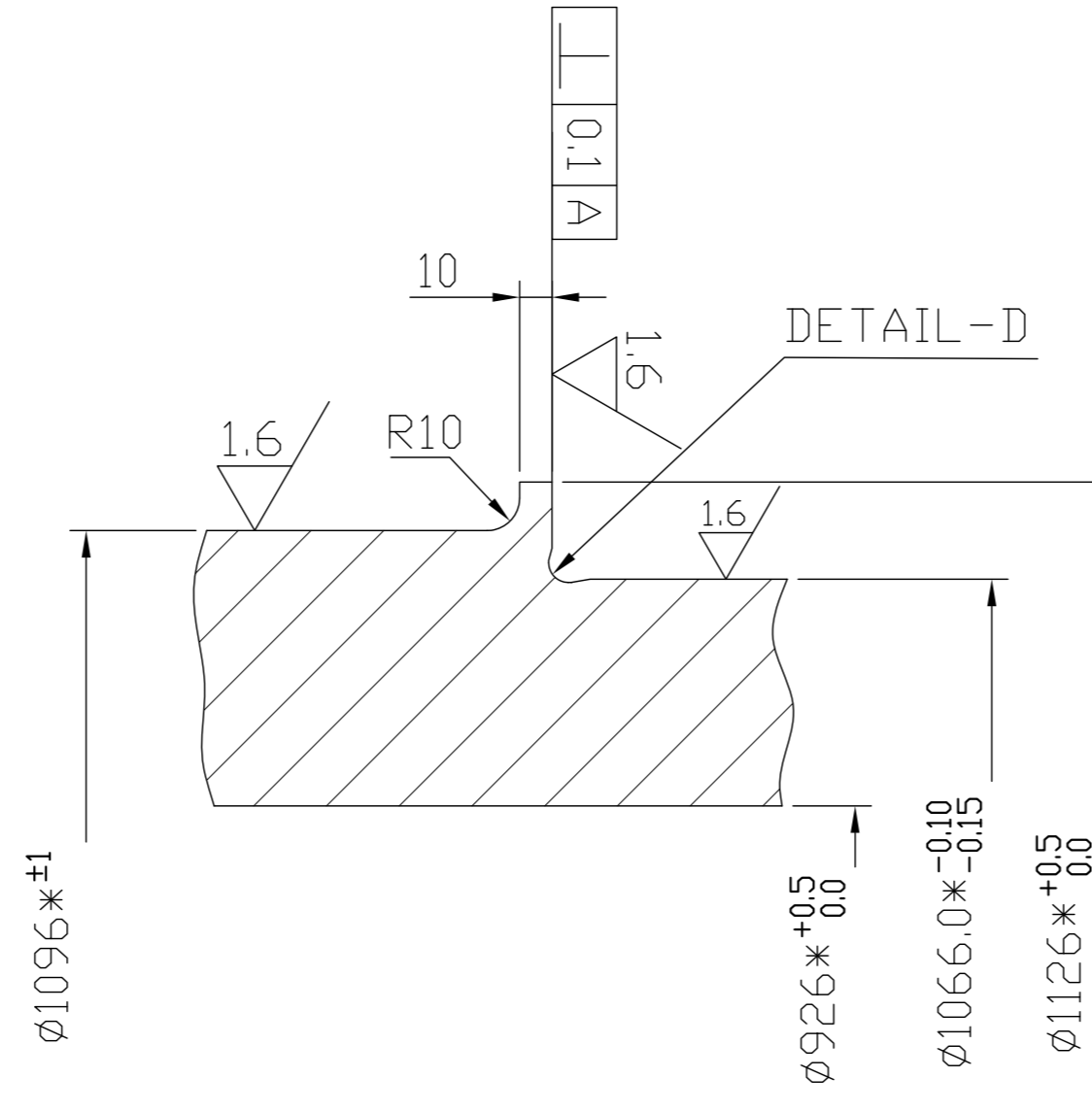

DETAIL-B

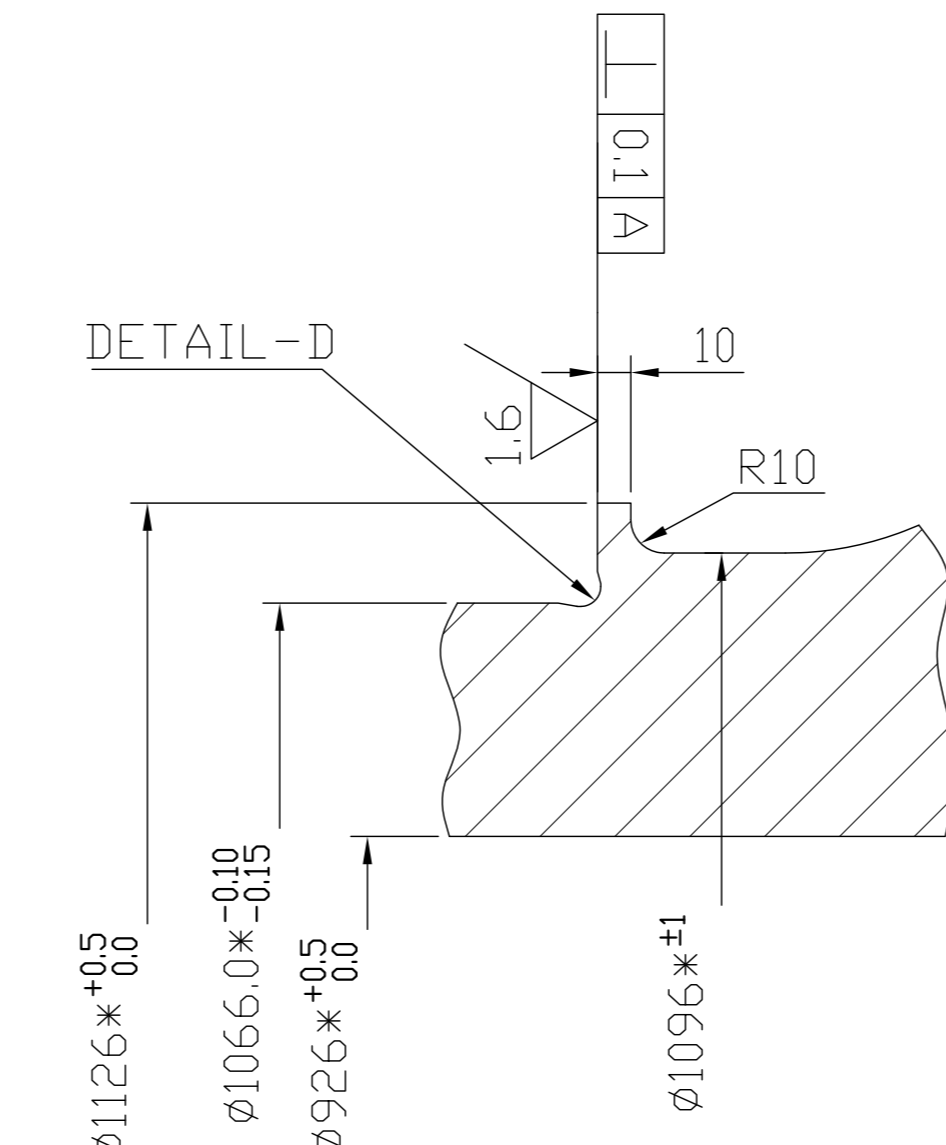

DETAIL-C

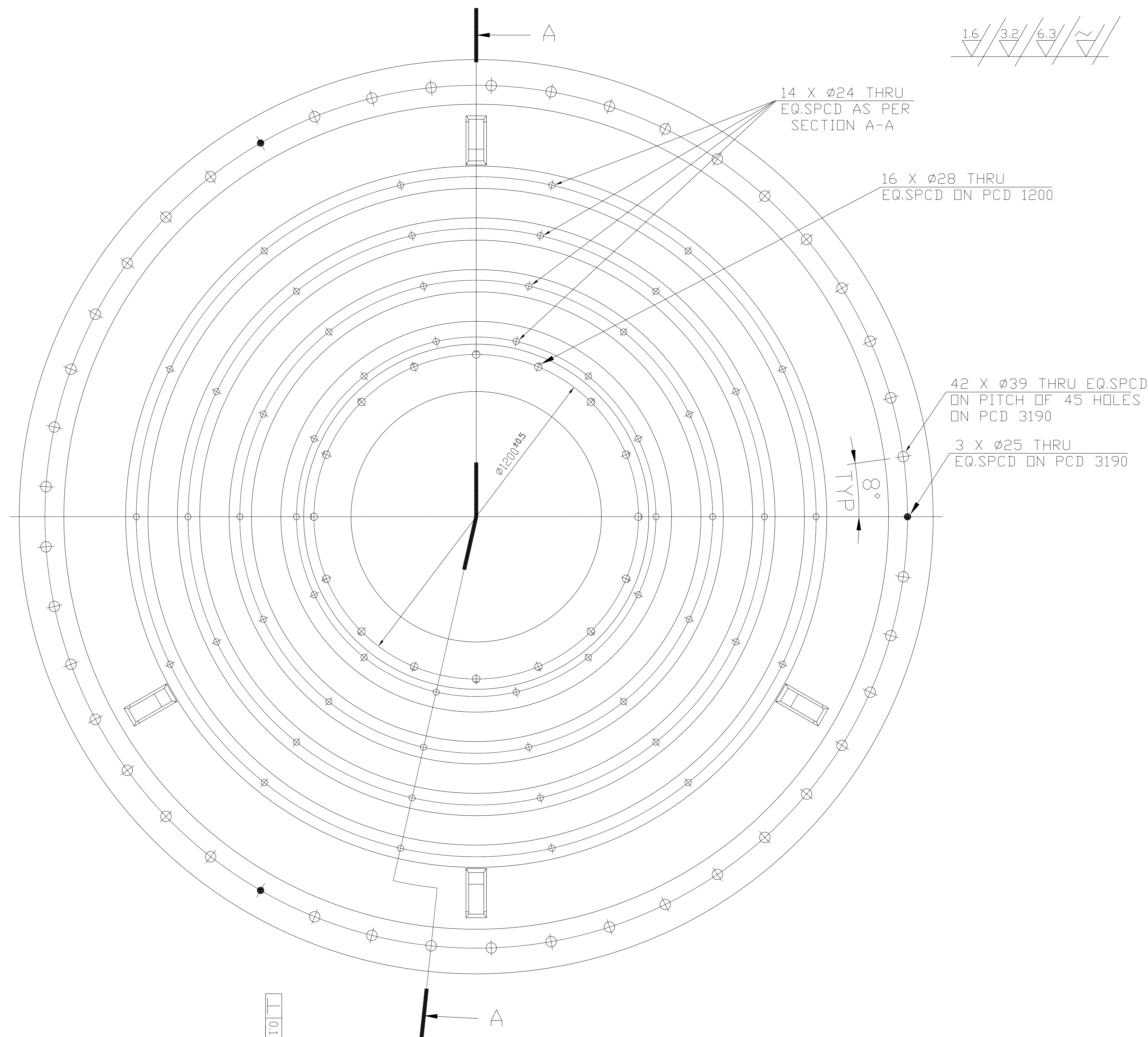

- NOTES:
1. PAINT AS PER APPROVED PAINTING STANDARD FOR THE PROJECT.
 2. FINAL DIMENSIONS TO BE MAINTAINED AS PER SECTION A-A, DETAILS B & C.
 3. CRITICAL DIMENSIONS INDICATED WITH *.

01	CHEEK TRUNNION R/M CASTING WITH LIFTING LUGS	3-62-215-00035			8367	01
ITEM NO.	DESCRIPTION	DRAWING NO.	VAR. NO.	RAW MATERIAL SIZE OR CASTING DRG. NO. OR FORGING DRG. NO.	MATERIAL CODE	NET WT. GROSS WT.
						QUANTITY

NON-CAST PARTS (FABRICATED AND/OR MACHINED)
 ALL DIMENSIONS ARE IN MILLIMETERS
 TOLERANCES UNLESS OTHERWISE NOTED:
 XXX ±0.40
 X & XX ±0.5 FOR DIM 0-610 MM
 X & XX ±0.8 FOR DIM 610-2440 MM
 X & XX ±0.3 FOR DIM OVER 2440
 FINISH: 40°Ra
 DRILLED HOLES: Ø 0-25MM +0.25/-0.00 OVER 25 MM +0.50/-0.00
 SURFACE TEXTURE: 25 MICRO METERS
 ROUGHNESS AVERAGE-Ra
 THIS DRAWING IS IN ACCORDANCE WITH ISO 1101 UNLESS OTHERWISE SPECIFIED, THE THREAD PITCH IS STANDARD COARSE.

TYPE OF PRODUCT: WET BALL MILLS
 NAME OF CUSTOMER/PROJECT: BHARAT HEAVY ELECTRICALS LIMITED HYDERABAD

REF. TO ASSY DRG. NO. 0-62-215-00022
 SCALE: NTS
 WEIGHT (KG): 6589.12
 NO. OF SHEETS: 16

DATE: 04.09.21
 NAME: SHARIFF
 DRN: K.P.A.V.
 APPR: AMAN

REV. NO. 00

THE INFORMATION ON THIS DOCUMENT IS THE PROPERTY OF BHARAT HEAVY ELECTRICALS LIMITED. IT MUST NOT BE USED DIRECTLY OR INDIRECTLY IN ANY WAY DETRIMENTAL TO THE INTEREST OF THE COMPANY.

COMP. FILE NAME: REF. DRG. NO. INVENTORY NO.

61000-012-29-1

DN 980

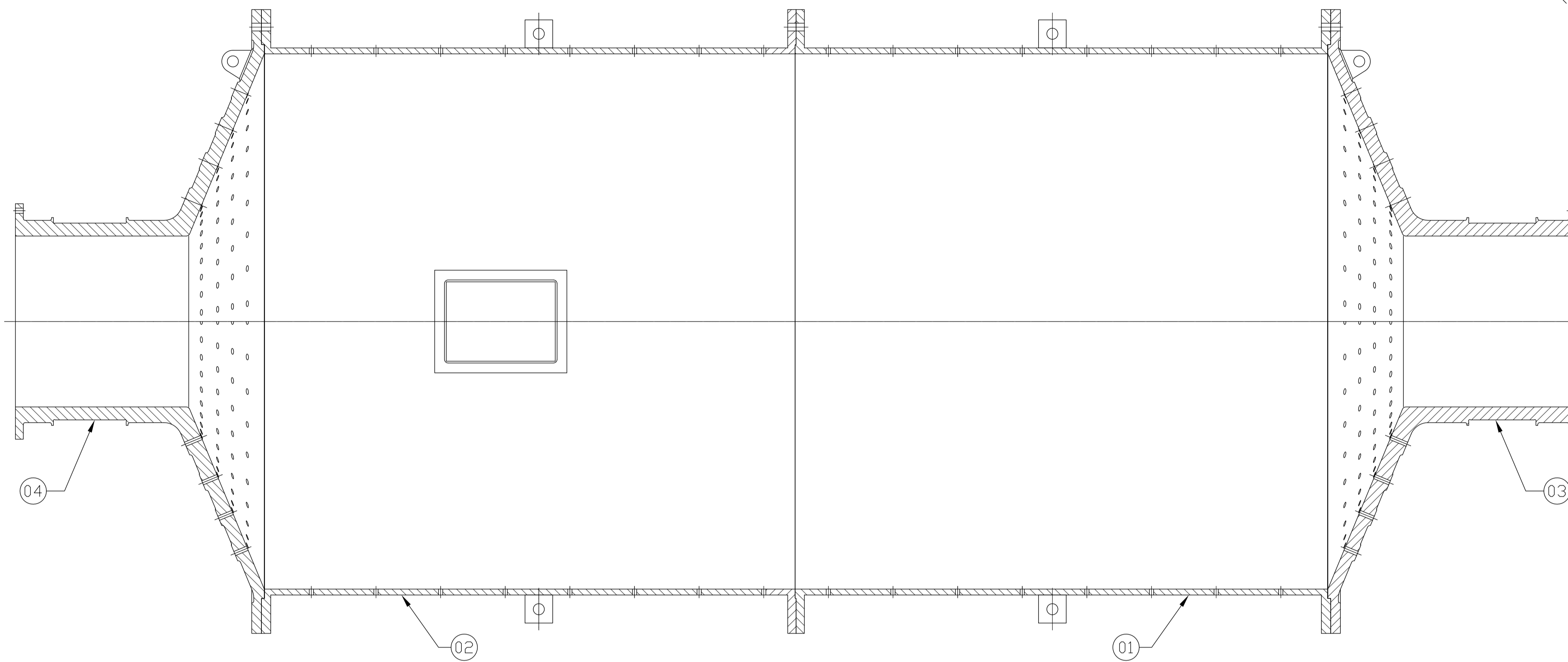

SECTION : A-A

3 X Ø42H7 THRU
EQ.SPCD ON PCD 3190
(ON BOTH FLANGES)

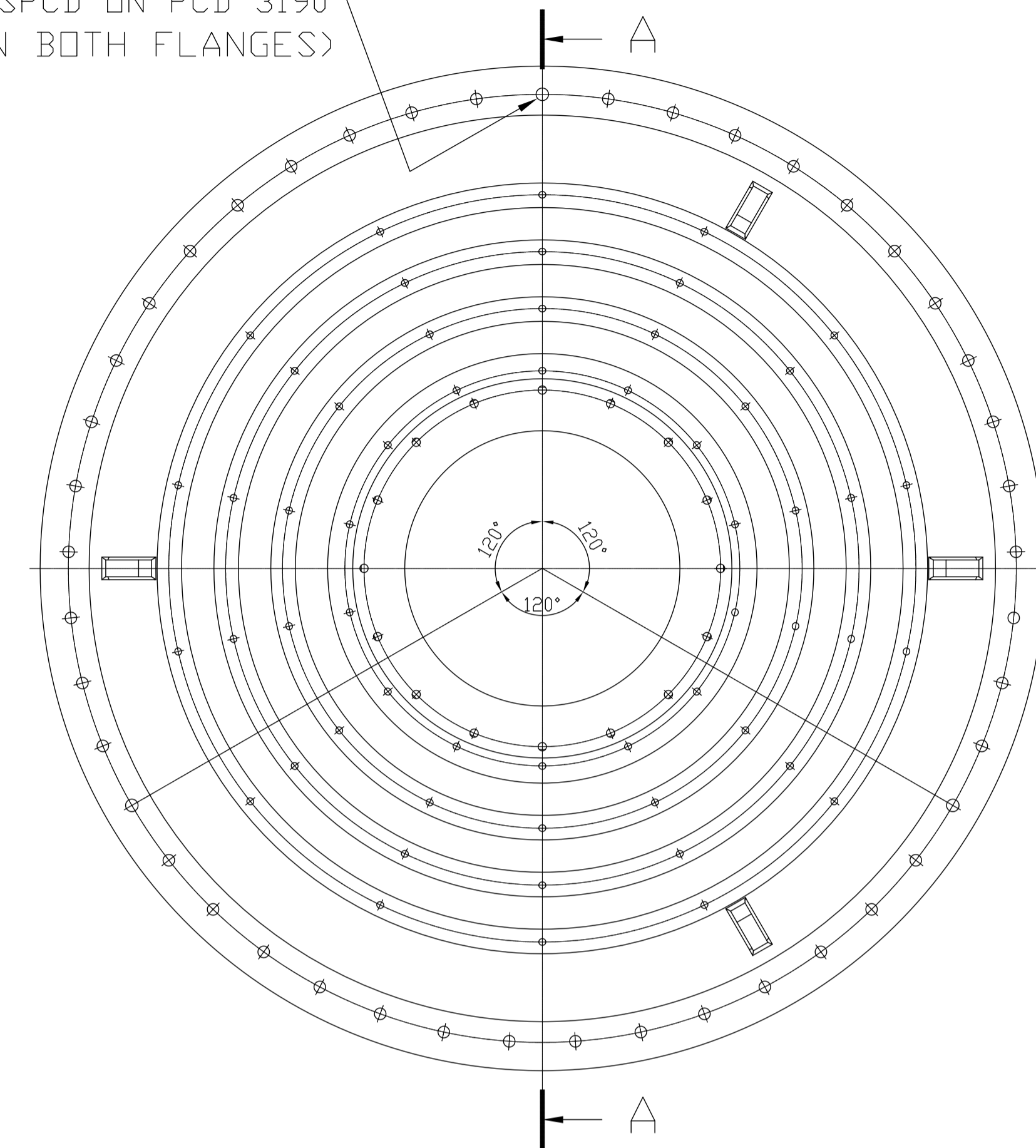

NOTES:

- MILL HALF SHELL DE AND CHEEK WITH TRUNNION DRIVE END SHALL BE HAND TIGHTENED USING 42 NOS OF SCREW M36X 140 (HY7121124610) AND M36 NUT (HY7151115946).
- COMBINED DRILLING AND REAMING OF SHELL AND CHEEK WITH TRUNNION FLANGE SHALL BE DONE ON THE EXISTING PILOT HOLES (Ø 25 MM : 3 NOS) TO ENLARGE THEM TO Ø 42H7 MM.
- REPEAT THE STEPS 1 AND 2 FOR MILL HALF SHELL NDE AND CHEEK WITH TRUNNION NON DRIVE END SIDE ALSO.
- THESE 42 NOS FASTNERS ARE ONLY FOR HOLDING THE ABOVE MENTIONED COMPONENTS.
- AFTER THIS OPERATION, MATCH MARKING SHALL BE DONE.

ITEM NO.	DESCRIPTION	DRAWING NO.	VAR. NO.	RAW MATERIAL SIZE OR CASTING DRG. NO. OR FORGING DRG. NO.	MATERIAL CODE	NET WT.	GROSS WT.
04	CHEEK TRUNNION NDE - Ø2.9M	0-62-215-00022				6589.12	
							01
03	CHEEK TRUNNION DE - Ø2.9M	0-62-215-00021				6601.84	
							01
02	MILL HALF SHELL MACHINING-NDE	0-62-215-00039				8410	
							01
01	MILL HALF SHELL MACHINING-DE	0-62-215-00038				8430	
							01

THE FOLLOWING CONDITIONS APPLY EXCEPT OTHERWISE STATED.

- REF. TO HY0230261 FOR UNSPECIFIED TOLERANCES.
- CHAMFER M/CD. SHARP EDGES AT 45°.
- INTERNAL M/CD. CORNER RADII 1 TO 0.7
- THE SURFACE ROUGHNESS WHERE-EVER NOT SHOWN SHALL BE TAKEN FROM THE SURFACE ROUGHNESS SHOWN OUT SIDE THE BACK SLASH GIVEN OR THE TOP MOST RIGHT CORNER OF THE DRG.

TYPE OF PRODUCT: WET BALL MILL
NAME OF CUSTOMER/PROJECT: BHARAT HEAVY ELECTRICALS LIMITED HYDERABAD

DRN.	NAME	SIGN.	DATE	NO. OF VAR.
CHD.	K.PAVAN		26.03.22	
APPD.	S.GHATGE		26.03.22	

DEPT.	UNTO.	DIMS.	GR.	SCALE	WEIGHT (KG)	REF. TO ASSY DRG.	ITEM NO.	NO. OF ITEMS
446				NTS	30030.96			

TITLE	CARD CODE	DRAWING NO.	REV.
MILL BODY ASSEMBLY		1-62-215-00019	00

REV.	DATE	ALTERED	REV.	DATE	ALTERED	REV.	DATE	ALTERED
ZONE		CHD./APPD.	ZONE		CHD./APPD.	ZONE		CHD./APPD.

THE INFORMATION ON THIS DOCUMENT IS THE PROPERTY OF BHARAT HEAVY ELECTRICALS LIMITED. IT MUST NOT BE USED DIRECTLY OR INDIRECTLY IN ANY WAY DETERIMENTAL TO THE INTEREST OF THE COMPANY

INVENTORY NO (SIGN. AND DATE) REF. DRG. NO. COMPUTER FILE NAME