

## ANNEXURE-I

**Special Instructions for supply of Supporting Plates as per BHEL drawing and  
Purchase specification No. AA19511  
( Drg. No. R7082.0421, R7082.0422 & R7082.0423 )**

---

Following special instructions shall also be applicable along with all other requirements specified in BHEL drawings and Purchase specification No. AA 19511 :-

- 1.0** MPE and UT shall be carried out by vendor to meet quality level-3 as per BHEL spec AA0850134 & AA0850105 respectively.
- 2.0** No porosity or shrinkage open to machined surfaces shall be acceptable.
- 3.0** Porosity or shrinkage which may come up after final machining to be informed by vendor to BHEL and repair of castings at such places is also in the scope of vendor after taking permission from BHEL.

1210-280024 No. SHARVARDI FIRST ANGLE PROJECTION (ALL DIMENSIONS IN M.M.) FORM DR. 4380

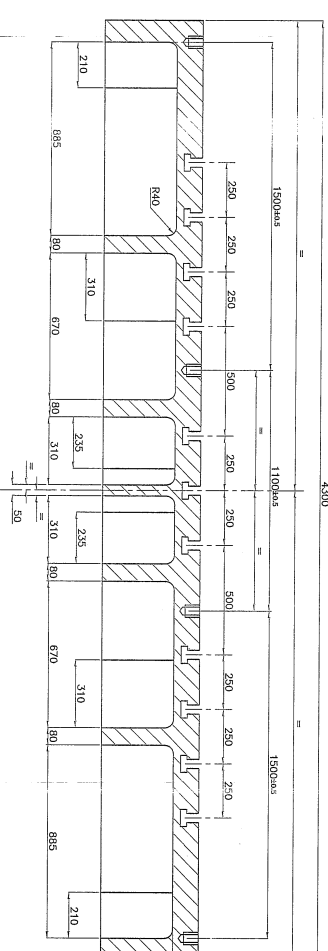

SECTION: C-C (ZONE-09/05)

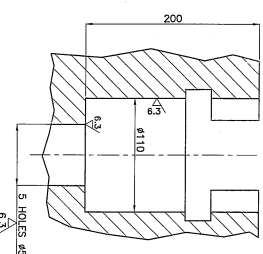

SECTION: G-G (ZONE-09)

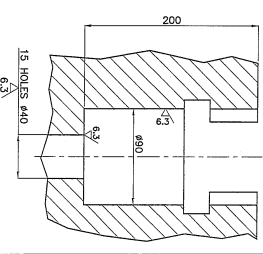

SECTION: F-F (ZONE-09)

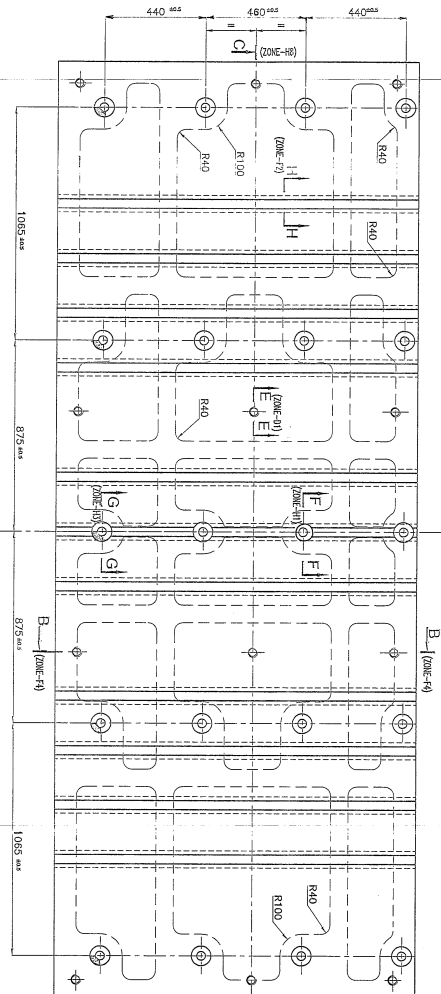

SECTION: B-B (ZONE-09/09)

SECTION: H-H (ZONE-09/10)

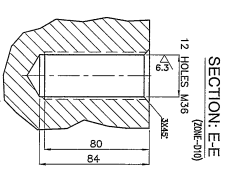
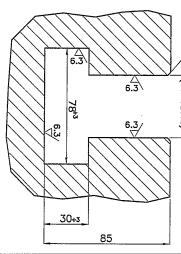
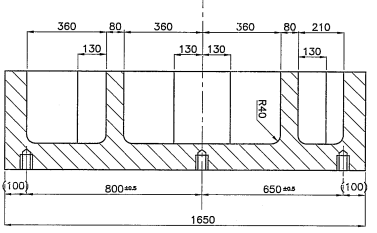

1. ALL UNSPECIFIED RILET BOUNDS TO BE R40, FOR CASTING.
2. WORKS OF ACCEPTANCE OR ULTRASONIC EXAMINATION TO BE AS PER QUALITY LEVEL-III, OF A4080105.
3. WORKS OF ACCEPTANCE OF WIRE TO BE AS PER QUALITY LEVEL-III, OF A4080134.
4. TO BE CONSERVED AS PER TL-30007

VAR. NO.	REMARKS	ITD.	NO.	DESCRIPTION	QTY.	UNIT WEIGHT	WGT.

PROJECT NAME	STATUS	DATE	DATE
BML SHG			

GRADE OF WELDING	WELDING	WELDING

DESIGNER	CHECKED	DATE

COMP. DRG. No.	DATE
01350401109-00	

SCALE	
1:1	

  

DRG. NO.	

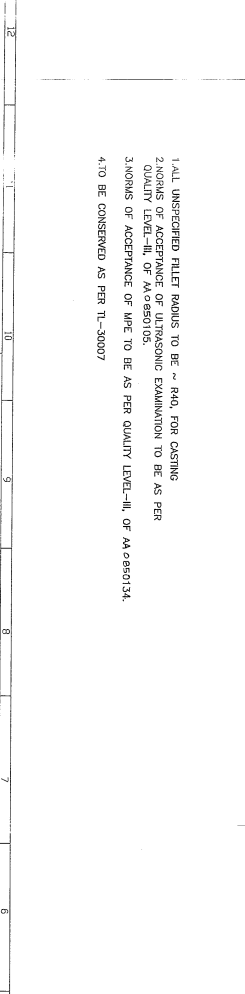

INVENTORY No. SIGN. & DATE REF. DRG. No.

FORM DC 45(B) 11 10 9 8 7 6 5 4 3 2

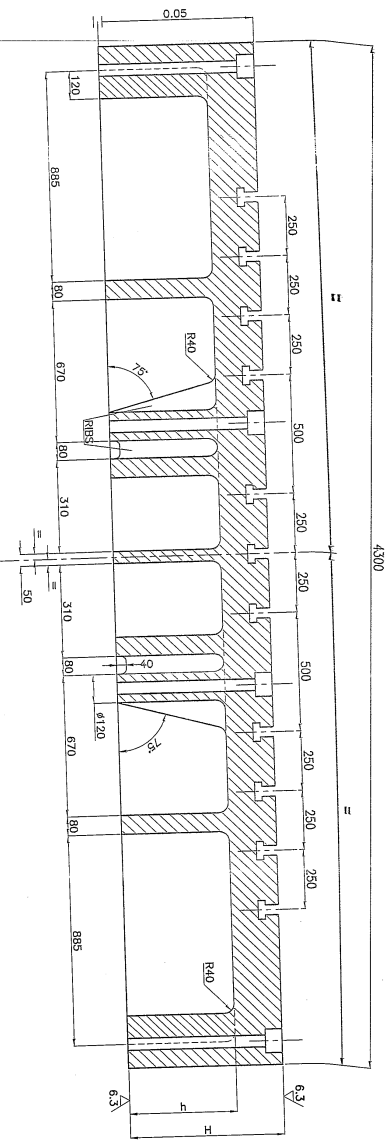

SECTION B-B (DME-012/09)

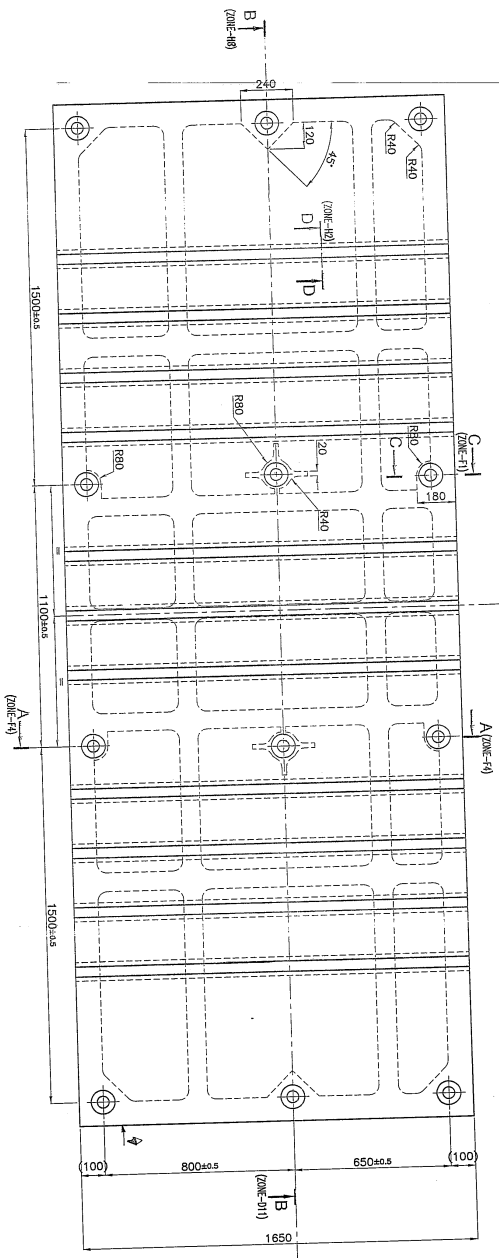

SECTION A-A (DME-R9/09)

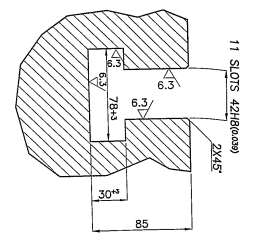

SECTION D-D (DME-F11)

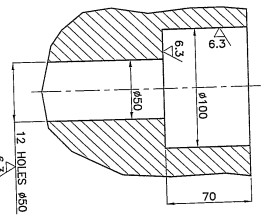

SECTION C-C (DME-F9)

DRAWING No.	W/O No.	H(mm)	h(mm)	WE in kg
F7082-0422 HDR	125/67/009	430	330	~12120
F7082-0423 HDR	125/67/010	650	530	~16665

VAR. NO.	REMARKS	ITEM NO.	DESCRIPTION	DRAWING NO.	VAR. MATERIAL SPEC.	QTY.	UNIT WEIGHT	ZONE
			SUPPORT PLATE	F7082-0423	A119511			
			SUPPORT PLATE	F7082-0422	A119511			

STATUS	TYPE OF PRODUCT	COMP. DRG. NO.	DESIGN ORDER NO.	MODEL NO.	REF. DRG. NO.
NEW	HDR-125/67	01350401108-00			F7082-0111 & 012

DATE	BY	CHECKED	DATE	BY	CHECKED

NO.	REV.	DATE	DESCRIPTION
1	NEW		INITIAL DESIGN
2	REV		CHANGED
3	REV		CHANGED

1. ALL UNSPECIFIED FILET RADII TO BE ~ R40, FOR CASTING
2. NORMS OF ACCEPTANCE OF ULTRASONIC EXAMINATION TO BE AS PER QUALITY LEVEL-III OF AS 9103.
3. NORMS OF ACCEPTANCE OF NDT TO BE AS PER QUALITY LEVEL-III OF AS 9134.
4. TO BE CONSERVED AS PER TL-30007

MARK  
DRG. NO.  
PRODUCT  
HEIGHT

TITLE	DEPT.	SCALE	DATE	BY	CHECKED
SUPPORTING PLATE	HRMNT HWY ELECTRONICS LTD	1:1			