



CORPORATE PURCHASING SPECIFICATION

AA10916

Rev No. 08

PAGE 1 of 9

COLD ROLLED NON-GRAIN ORIENTED SHEET STEEL – Gr: 350

1 GENERAL

This specification governs the quality requirements of Un-insulated and insulated (double side), cold rolled, non-grain oriented magnetic steel sheet or coil in finally annealed condition in 0.50 and 0.65 mm thickness.

2 APPLICATION

Laminations of Electrical Machines

3 CONDITION OF DELIVERY

3.1 Cold rolled, finally annealed.

3.2 The material shall be supplied in straight lengths (sheet form) or in coils, to the ordered thickness as specified in BHEL order.

3.3 Magnetic steel sheets or coils shall be supplied with or without insulation coating, as detailed below and as called for on BHEL order.

a) 0.50mm/0.65mm Thick - insulated (6 Microns)*

Double side insulated with an average of 6±1 micron thickness coating on each side. This insulation of coating shall comply with clause 3.4 and 8.6 of this specification.

b) 0.50mm/0.65mm Thick - insulated (5.5 Microns)*

Double side insulated with an average of 5.5±1.5 micron thickness coating on each side. The insulation shall comply with clause 3.4 and 8.6 of this specification.

c) 0.50mm/0.65mm Thick – Un-insulated*

Un-insulated, protected on both sides by rust preventive coating of thickness 2±1 microns.

*NOTE

i) The supplier shall furnish the details of such coatings along with the quotation. (for insulation coating, these details shall be furnished as per Annexure-1 of BHEL standard AA0851711) for approval of BHEL prior to the first time supply and / or as when the type of coating is changed subsequently with the prior approval of BHEL.

ii) The surface finish of the material shall be such as to allow subsequent uniform varnishing, if required, without any problem.

3.4 Type of insulation coating

The insulation coating used for the steel sheets referred in clause 3.3 (a) shall be uniformly applied, tightly adherent and shall be as per BHEL specification AA27541 or as per AISI, C-6 of the filler base type on both sides, pigmented varnish coating (in which case it shall be compatible to varnish as per AA27541) and also suitable for fully impregnated electrical machines (VPI) and shall meet the requirements detailed in clause 8.6.

Revisions:
Brought upto date

APPROVED:
INTERPLANT MATERIAL RATIONALISATION
COMMITTEE – MRC(E&IM)

Rev No.08

Amd No.

Reaffirmed

Prepared
HEEP, Haridwar

Issued
Corp.R&D

Dt. of 1st Issue
01-06-1993

Dt:15-06-2017

Dt:

Year:

COPYRIGHT AND CONFIDENTIAL
The information on this document is the property of BHARAT HEAVY ELECTRICALS LIMITED. It must not be used directly or indirectly in any way detrimental to the interest of the company.

DRC-R5119



4 COMPLIANCE WITH NATIONAL STANDARDS

Material shall comply with the requirements of the following national standards and also meet the requirements of this specification.

IS 648-2006

Gr: 50C350 for 0.5mm thick and } Non-oriented electrical steel sheets and strips for magnetic circuits
Gr: 65C350 for 0.65mm thick }

Material offered to EN 10106-2015, Gr: M350-50A for 0.50mm thick and M350-65A for 0.65mm thick is also acceptable.

5 DIMENSIONS AND TOLERANCES

5.1 Sizes

Magnetic steel sheet shall be supplied to the dimensions and coating specified on BHEL order.

5.2 Tolerances

5.2.1 Thickness

The permissible deviation in nominal thickness shall be $\pm 8\%$. The variation in thickness in a direction parallel to the direction of rolling shall not exceed $\pm 8\%$ of the nominal thickness.

The variation in thickness in a direction perpendicular to the direction of rolling shall be $\pm 0.020\text{mm}$ for a nominal thickness of 0.50mm and $\pm 0.030\text{mm}$ for 0.65mm thick. The measuring points should be at least 40mm away from the edges of the sheets.

5.2.2 Width

The tolerance for width of material supplied with trimmed edges shall be as follows:

| Width (mm) | | Tolerance (mm) | |
|------------|---------------|----------------|-------|
| Over | Upto & incld. | Plus | Minus |
| - | 150 | 0.3 | 0 |
| 150 | 500 | 0.5 | 0 |
| 500 | 1250 | 1.5 | 0 |

5.2.3 Length

When supplied in sheet form the tolerance on length shall be $+1\%$, but shall not exceed $+10$ mm.
 -0

5.2.4 Straightness/Edge camber

The straightness tolerances for the longitudinal edge (edge camber) over a gauge length of 2000mm shall not exceed 4mm for width up to and including 150mm and 2mm for widths exceeding 150mm.

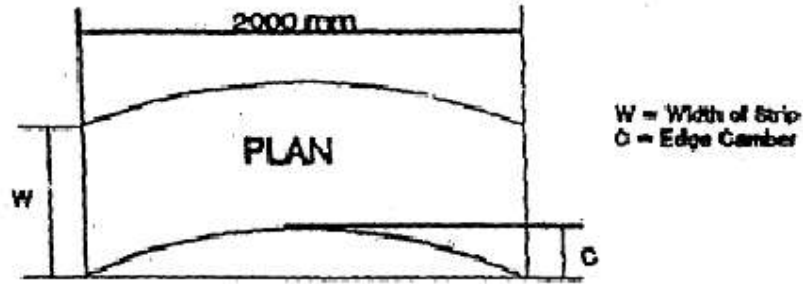

5.2.5 Edge Burr

The height of edge burr shall not exceed 50 microns.

5.2.6 Bowing – Coils

The material when unwound from a coil shall be placed flat on a level smooth surface (surface plate) such that it has a radius not less than 3000mm. The specimen should be stood upright and free from constraint with one longitudinal edge on the surface of the plate. A straight edge with a length of 500mm, when placed against the specimen and when measuring the greatest distance 'h' between the straight edge and the product should not be more than 10 mm as detailed below:

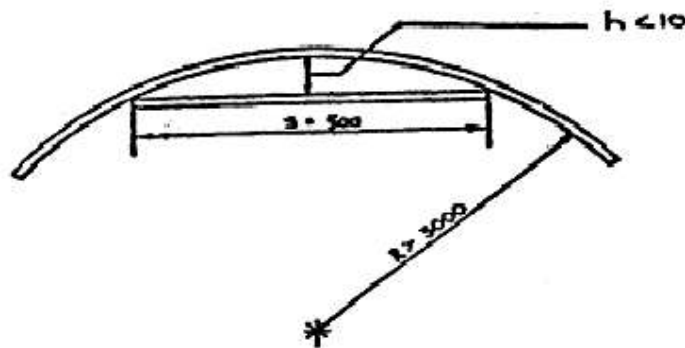

5.2.7 Waviness/Flatness

The Waviness/Flatness shall not exceed 1.5% (i.e the ratio of the wave height to wave length).

6 FINISH

The material shall have a smooth surface and shall be free from loose scale, buckle or dents, waviness and internal stresses.

7 TEST SAMPLES

The test samples of the same heat/melt & thickness shall be selected from the consignment as follows

| | |
|-----------------------|-----------|
| Upto 30 tonnes | 1 sample |
| Above 30 to 60 tonnes | 2 samples |
| Above 60 tonnes | 3 samples |

The test samples shall be sufficient in size to provide the necessary test pieces.



8 PROPERTIES (AS RECEIVED)

8.1 Bend Test

A test piece of 30mm width X 60mm long taken in rolling direction in the ordered thickness shall withstand the minimum number of bends specified below, without fracture, through 90° from initial position; then bend it through 180° in the reverse direction. Again bend the specimen through 180° in the first direction and continually through 180° reversals, over a 5mm radius jaws when tested to IS 649/ EN 10106.

0.50mm thick: 5 bends

0.65mm thick: 2 bends

8.2 Stacking Factor

The surface quality of the sheets when measured in terms of stacking factor as per IS 649 (on a minimum of 16 samples under a pressure of 35 N/cm²) shall be as follows:

0.50mm and 0.65mm thick double side coating (insulated) : 95.5%, minimum

0.50mm and 0.65mm thick un-insulated : 96.0% minimum

8.3 Total Specific Loss

The total specific loss on aged specimens (a specimen which has been heated for 24 hrs. at 225±3°C) for 0.50mm thick and on unaged specimen for 0.65mm thick sheet shall be as follows, when tested as per IS 649 at a frequency of 50 Hz for the specified flux density.

- 3.50 watts/kg, Maximum – At 1.5 Tesla
- Note: A tolerance of +2% on the above value is allowed.

8.4 A.C Magnetization

When tested to IS 649, the AC magnetic field (H) in ampere/metre (Peak), shall show the following minimum corresponding values of magnetic induction (B) in Tesla (Peak) for 0.50mm and 0.65mm thick material.

| AC Magnetic field Strength 'H' A/m (Peak) | Magnetic Induction Min. (Peak) | (B) Tesla |
|---|--------------------------------|-----------|
| Thickness | 0.50 mm | 0.65 mm |
| 2500 | 1.50 | 1.49 |
| 5000 | 1.60 | 1.60 |
| 10000 | 1.70 | 1.70 |



8.5 Anisotropy of Losses

When tested to IS 649/EN 10106 as detailed below, the Anisotropy losses shall not exceed:

±12% for 0.50mm thick sheet

±14% for 0.65mm thick sheet

To determine the loss ANISOTROPY the specific total loss should be measured separately on specimens taken parallel and perpendicular to the rolling direction. The loss Anisotropy, in percent, is found from the following expression

$$\frac{P_a - P_l}{P_a + P_l} \times 100 \text{ where}$$

P_a denotes specific total losses perpendicular to the rolling direction.

P_l denotes the specific total losses parallel to the rolling direction.

8.6 Testing of insulation coating

The insulation coating when tested in accordance with BHEL standard AA0851711: Test Methods for Insulation Coating on Magnetic Steel Sheets, shall show the following properties:

8.6.1 Selection of Test Samples for Insulation Coating

The outermost and innermost turn of coil or the topmost and bottommost of a stack of sheets, shall be considered as wrapping and not representing the properties of the remaining material and hence shall not be considered for test specimen.

In case of coils, the test specimens shall be preferably taken from the first external turn excluding the wrapping turn and in case of sheet, it shall be from the upper part of the stack. In special case, it can be taken from any other part also.

The test specimen shall extend over the entire sheet width and can be about 350 ± 2mm long. In case of sheet width, below 400mm, the specimen shall be 500 ± 2mm long.

The surface of the strip shall be free from contaminations & damages and shall be cut without deformation and as far as possible, without burrs. Any cleaning done shall not damage the insulation coating.

8.6.2 Coating Layer Thickness

Both sides of the sheet shall be coated and shall have a thickness as per applicable section of clause 3.3 on each side. At least 15 readings shall be taken on each side at equal intervals.

- None of the readings should be below 2.0 microns for insulation coating as per clause 3.3 b)
- 90% of the readings shall be between 4.5 to 9 microns for insulation as per clause 3.3.a)

The thickness of any pre-coating shall not be accounted for.

8.6.3 Surface insulation Resistivity

When tested as per ASTM A717 (Franklin's method) at a pressure of 2N/mm² at room temperature or any other international standard (in that case, approval to be taken by the supplier). The minimum average of 10 non-overlapping resistance measurements (5 on each side) shall be 30 ohm-cm² with a minimum allowable individual value of 10 ohm-cm².



8.6.4 Type Tests

8.6.4.1 Adherence Test

The surface coating shall be sufficiently adherent so that it does not get detached during insulation and shearing. In the reverse bending test with a bending radius of 5mm, the surface coating shall not be detached after bending through 90°.

8.6.4.2 Thermal Effect on Coating

Twelve specimens of the coated strip shall be clamped together under a pressure of 1 N/mm² approximately and heated in a laboratory oven at a temperature of 180±3°C for a period of 7 days. After cooling to room temperature, the surface insulation resistivity values of the middle ten specimens shall not be less than the minimum specified values mentioned in clause 8.6.3.

8.6.4.3 Resistance to Solvents, Oils & Ammonia

The specimens shall be kept in a container filled with any of the following solvents/oil and boiled for 5 minutes. After removal and cooling to the room temperature the coating shall not get soft enough so that it can be wiped off. The insulation coating film shall be resistant to conventional organic solvents like trichloroethylene, methylated spirit, acetone, benzene, and oil, etc. In special cases and when specified on BHEL order, the insulating film shall be resistant to ammonia also.

* Note

Type tests shall be carried out when, 'Type Approval' to a supplier is given and repeated once in five years for the approved supplier.

9 TEST CERTIFICATES

Three copies of test certificates shall be supplied, unless otherwise specified on order. In addition, the supplier shall ensure to enclose one copy of the test certificate along with their despatch documents to facilitate quick clearance of the material.

The test certificate shall bear the following information

AA10916-Rev 08 / IS 648, Gr: 50C350/Gr: 65C350/ EN 10106, Gr: M350-50A/Gr: M350-65A/
ASTM A 677

BHEL Order No.

Supplier's Name/Grade/Identification No.

Size & Weight

Melt No., Packet/Bundle No.

Test results of

- a) Dimensions & Tolerances
- b) Properties as per the concerned National standards & insulation coating, as above.

Also type test certificates, not older than 5 Years, shall be submitted along with each consignment.

10 PACKING AND MARKING

10.1 Material Supplied in Straight Length

Magnetic steel sheets shall be supplied in bundles. The packing shall be seaworthy and shall protect the material from damage during transit. A typical packing which would be suitable is shown below.

Each sheet shall be marked with supplier's grade/references.

These markings shall be along the rolling direction.

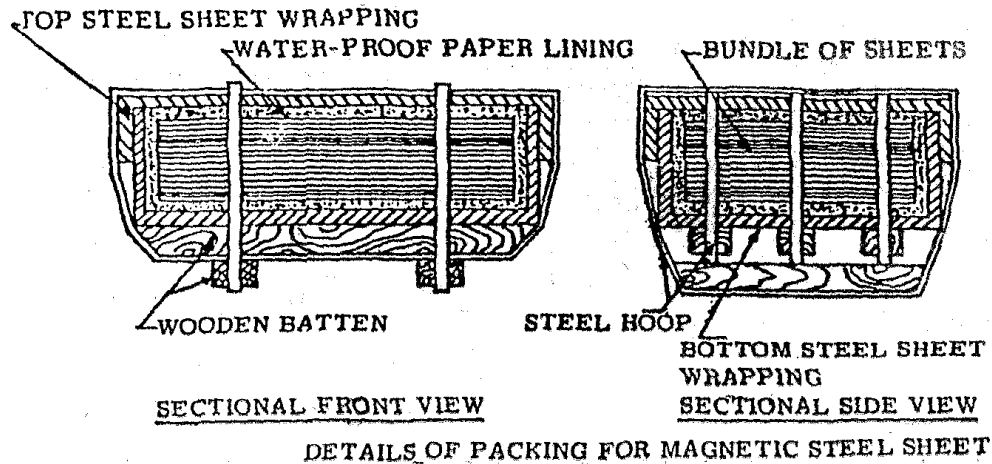

Note:

- a) Water proof paper lining shall be preferably Volatile Corrosion Inhibitor (V.C.I) Coated Paper with an additional polythene (100 micron) enveloped.
- b) Approximate weight of each bundle shall be 2 to 3 metric tonnes. Bundle weighing 2 Metric tonnes is however preferred.
- c) The packing should ensure that there is no seepage of moisture and the sheets reach BHEL on completely rust free condition. It shall be strong enough to withstand handling at the docks, at sea on the road.

10.2 Material Supplied in Continuous Coil

The nominal weight of each coil shall be 1800-2000kg.

The nominal internal diameter of coil shall be 508mm.

Packing shall be sea-worthy and shall protect the coils from damage and rusting during transit. The supplier's grade /reference shall be marked at every one metre intervals throughout the coil length.

Coils shall be vertically packed according to the instructions and drawing given below:

- a) An annular protection board shall be placed at either end of coil.
- b) The coil shall then be wrapped with waterproof anti-rust proof by lapping axially all around the circumference.
- c) The coil shall then be covered by polyethylene sheet or anti-rust waterproof paper and the ends sealed properly.
- d) A galvanized sheet shall be wrapped on the outside of the coil and the top and bottom of the coils. Care shall be taken to ensure that the ends of the top and bottom of the coils extend sufficiently over the inside diameter of the coil.
- e) A galvanised sheet shall be wrapped on the inside of the coil. Care shall be taken that it overlaps sufficiently over the ends of the sheet mentioned in (d) above.
- f) Steel ring made from thick angle sheets shall be placed on the rim of the inner diameter at both ends of the coil. The rings shall be held at either ends at four points by steel bands.
- g) The coil should then be mounted on wooden skids held together by steel bands. Wooden skids must have cutouts to house the steel bands for tight fit and to avoid slippage.
- h) The packing shall ensure that there is no seepage of moisture and the coils reach BHEL in completely rust free condition. It shall be strong enough to withstand handling.

- i) Coils shall be sufficiently tight-wound to prevent collapse to an extent that would preclude their being mounted on a mandrel appropriate to the ordered internal diameter.
- j) Each package should indicate the Sling Position, for lifting without damage. It is preferable to fix a suitable size of, 'Sheet Steel Angle', at the position where the Sling Rope is to be fitted to avoid slippage/damage/breakage of the wooden skid at four places.

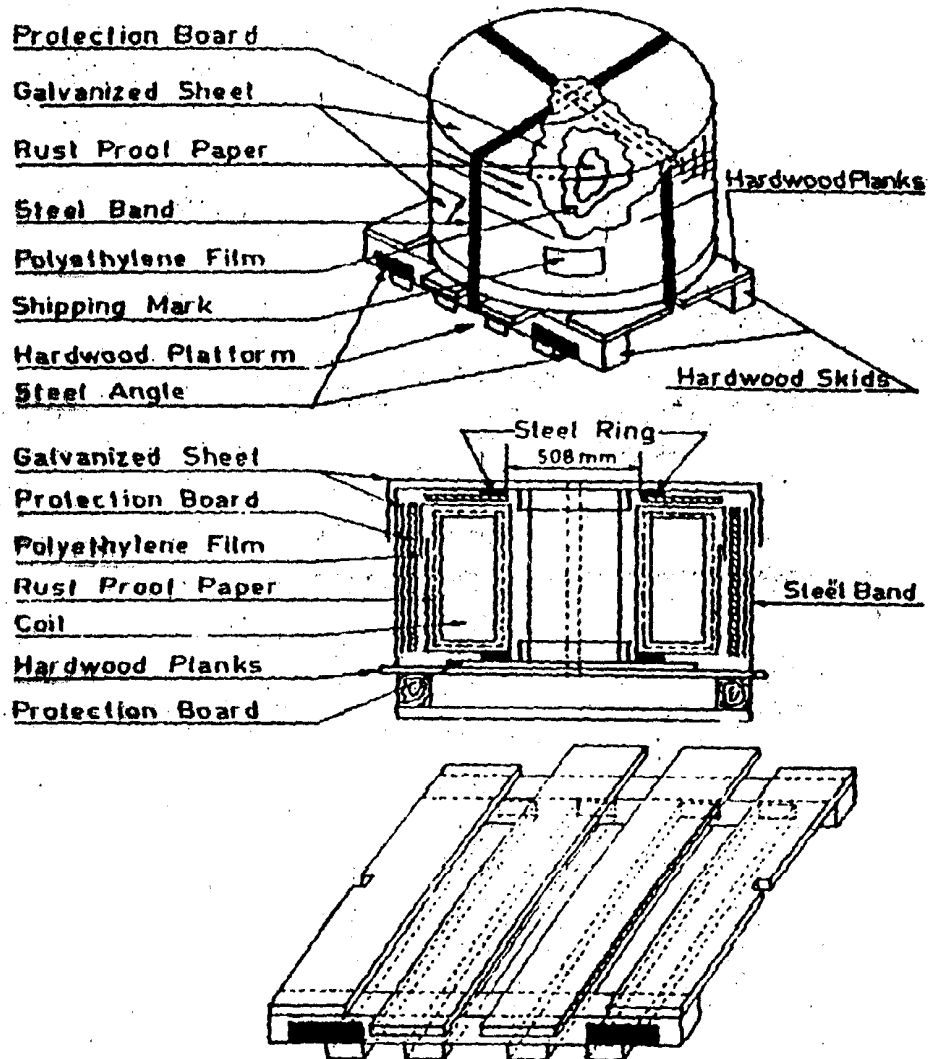

10.3 Marking

A metal label/tag shall be securely attached with each bundle outside its wrapping and shall be legibly marked with the following information.

AA10916

BHEL Order No.

Supplier's Name/Grade/Identification No.

Size & Weight

Melt No., Packet/Bundle No.



CORPORATE PURCHASING SPECIFICATION

AA10916

Rev No. 08

PAGE 9 of 9

11 REFERRED STANDARDS (Latest Publications Including Amendments)

- 1) AA0851711
- 2) AA27541
- 3) IS 649
- 4) ASTM A717
- 5) AISI C-6
- 6) ASTM A 677

GENERAL INFORMATION FOR CALCUALTION (NOT MANDATORY/TYPICAL VALUES)

Density : 7.65 kg/cm³
Total specific loss at 1.0 Tesla : 1.50 watts/kg for 0.50mm and 0.65mm thick
Magnetic induction (B) (Peak) at 30,000 A/M } Values to be furnished for information
AC magnetic field strength (H) (Peak) }

Mechanical Properties:

Tensile strength : 530 N/mm²
Yield strength : 417 N/mm²
Elongation on 5.65 $\sqrt{S_0}$ GL : 14%



CORPORATE PURCHASING SPECIFICATION

AA10917

Rev No. 07

PAGE 1 of 9

**COLD ROLLED NON-GRAIN ORIENTED SHEET STEEL – Gr: 530
(DIFFERENT TYPE OF INSULATION COATING)**

1 GENERAL

This specification governs the quality requirements of Un-insulated and insulated (double side), cold rolled, non-grain oriented magnetic steel sheet or coil in finally annealed condition in 0.50 and 0.65 mm thickness.

2 APPLICATION

Laminations of Electrical Machines

3 CONDITION OF DELIVERY

3.1 Cold rolled, finally annealed.

3.2 The material shall be supplied in straight lengths (sheet form) or in coils, to the ordered thickness as specified in BHEL order.

3.3 Magnetic steel sheets or coils shall be supplied with or without insulation coating, as detailed below and as called for on BHEL order.

a) 0.50mm/0.65mm Thick - insulated *

Double side insulated with an average of 5.5±1.5 micron thickness coating on each side. The insulation coating shall comply with clause 3.4 and 8.6 of this specification.

b) 0.50mm/0.65mm Thick – Un-insulated*

Un-insulated, protected on both sides by rust preventive coating of thickness 2±1 microns.

*NOTE

i) The supplier shall furnish the details of such coatings along with the quotation as per Annexure-I of BHEL standard AA0851711 for approval of BHEL prior to the first time supply and / or as when the type of coating is changed subsequently with the prior approval of BHEL.

ii) The surface finish of the material shall be such as to allow subsequent uniform varnishing, if required, without any problem.

3.4 Type of insulation coating

The insulation coating used for the steel sheets referred in clause 3.3 (a) shall be uniformly applied, tightly adherent and shall be as per BHEL specification AA27541 or as per AISI, C-6 of the filler base type on both sides, pigmented varnish coating (in which case it shall be compatible to varnish as per AA27541) and also suitable for fully impregnated electrical machines (VPI) and shall meet the requirements detailed in clause 8.6.

COPYRIGHT AND CONFIDENTIAL
The Information on this document is the property of BHARAT HEAVY ELECTRICALS LIMITED.
It must not be used directly or indirectly in any way detrimental to the interest of the company.

Revisions:
Brought upto date

APPROVED:
INTERPLANT MATERIAL RATIONALISATION
COMMITTEE – MRC(E&IM)

Rev No.07

Amd No.

Reaffirmed

Prepared
HEEP, Haridwar

Issued
Corp.R&D

Dt. of 1st Issue
01-06-1993

Dt:15-06-2017

Dt:

Year:

DRC-R5120



4 COMPLIANCE WITH NATIONAL STANDARDS

- 4.1 Material shall comply with the requirements of IS 648-2006 Gr: 50C530 for 0.5mm thick and Gr: 65C530 for 0.65mm thick.
- 4.2 Material offered to EN 10106-2015, Gr: M530-50A for 0.50mm thick and M530-65A for 0.65mm thick is also acceptable.

5 DIMENSIONS AND TOLERANCES

5.1 Sizes

Magnetic steel sheet shall be supplied to the dimensions and coating specified on BHEL order.

5.2 Tolerances

5.2.1 Thickness

The permissible deviation in nominal thickness shall be $\pm 8\%$. The variation in thickness in a direction parallel to the direction of rolling shall not exceed $\pm 8\%$ of the nominal thickness.

The variation in thickness in a direction perpendicular to the direction of rolling shall be $\pm 0.020\text{mm}$ for a nominal thickness of 0.50mm and $\pm 0.030\text{mm}$ for 0.65mm thick. The measuring points should be at least 40mm away from the edges of the sheets.

5.2.2 Width

The tolerance for width of material supplied with trimmed edges shall be as follows:

| Width (mm) | | Tolerance (mm) | |
|------------|---------------|----------------|-------|
| Over | Upto & incld. | Plus | Minus |
| - | 150 | 0.3 | 0 |
| 150 | 500 | 0.5 | 0 |
| 500 | 1250 | 1.5 | 0 |

5.2.3 Length

When supplied in sheet form the tolerance on length shall be +1%, but shall not exceed +10 mm.
-0

5.2.4 Straightness/Edge camber

The straightness tolerances for the longitudinal edge (edge camber) over a gauge length of 2000mm shall not exceed 4mm for width up to and including 150mm and 2mm for widths exceeding 150mm.

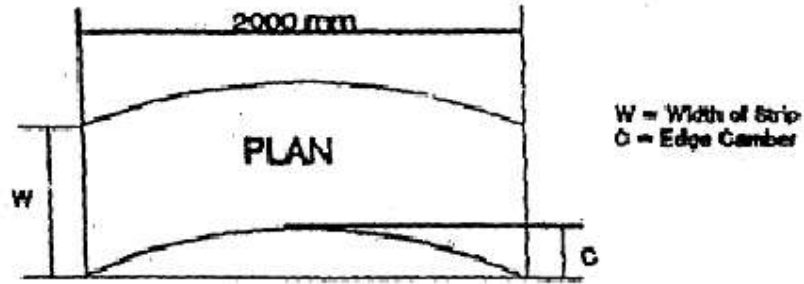

5.2.5 Edge Burr

The height of edge burr shall not exceed 50 microns.

5.2.6 Bowing – Coils

The material when unwound from a coil shall be placed flat on a level smooth surface (surface plate) such that it has a radius not less than 3000mm. The specimen should be stood upright and free from constraint with one longitudinal edge on the surface of the plate. A straight edge with a length of 500mm, when placed against the specimen and when measuring the greatest distance 'h' between the straight edge and the product should not be more than 10 mm as detailed below:

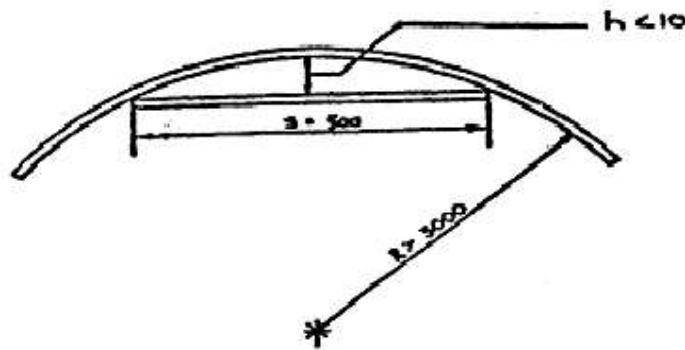

5.2.7 Waviness/Flatness

The Waviness/Flatness shall not exceed 1.5% (i.e the ratio of the wave height to wave length).

6 FINISH

The material shall have a smooth surface and shall be free from loose scale, buckle or dents, waviness and internal stresses.

7 TEST SAMPLES

The test samples of the same heat/melt & thickness shall be selected from the consignment as follows

| | |
|-----------------------|-----------|
| Upto 30 tonnes | 1 sample |
| Above 30 to 60 tonnes | 2 samples |
| Above 60 tonnes | 3 samples |

The test samples shall be sufficient in size to provide the necessary test pieces.



8 PROPERTIES (AS RECEIVED)

8.1 Bend Test

A test piece of 30mm width X 60mm long taken in rolling direction in the ordered thickness shall withstand the minimum number of bends specified below, without fracture, through 90° from initial position; then bend it through 180° in the reverse direction. Again bend the specimen through 180° in the first direction and continually through 180° reversals, over a 5mm radius jaws when tested to IS 649/ EN 10106.

0.50mm thick: 10 bends

0.65mm thick: 5 bends

8.2 Stacking Factor

The surface quality of the sheets when measured in terms of stacking factor as per IS 649 (on a minimum of 16 samples under a pressure of 35 N/cm²) shall be as follows:

0.50mm and 0.65mm thick double side coating (insulated) : 95.5%, minimum

0.50mm and 0.65mm thick un-insulated : 97% minimum

8.3 Total Specific Loss

The total specific loss on aged specimens (a specimen which has been heated for 24 hrs. at 225±3°C) for 0.50mm thick and on unaged specimen for 0.65mm thick sheet shall be as follows, when tested as per IS 649 at a frequency of 50 Hz for the specified flux density.

5.30 watts/kg, Maximum – At 1.5 Tesla

8.4 A.C Magnetization

When tested to IS 649, the AC magnetic field (H) in ampere/metre (Peak), shall show the following minimum corresponding values of magnetic induction (B) in Tesla (Peak) for 0.50mm and 0.65mm thick material.

| AC Magnetic field Strength 'H' A/m (Peak) | Magnetic Induction Min. (Peak) | (B) Tesla |
|---|--------------------------------|-----------|
| Thickness | 0.50 mm | 0.65 mm |
| 2500 | 1.50 | 1.52 |
| 5000 | 1.64 | 1.62 |
| 10000 | 1.74 | 1.72 |



8.5 Anisotropy of Losses

When tested to IS 649/EN 10106 as detailed below, the Anisotropy losses shall not exceed:

±10% for 0.50mm thick sheet

±12% for 0.65mm thick sheet

To determine the loss ANISOTROPY the specific total loss should be measured separately on specimens taken parallel and perpendicular to the rolling direction. The loss Anisotropy, in percent, is found from the following expression

$$\frac{P_a - P_l}{P_a + P_l} \times 100 \text{ where}$$

P_a denotes specific total losses perpendicular to the rolling direction.

P_l denotes the specific total losses parallel to the rolling direction.

8.6 Testing of insulation coating

The insulation coating when tested in accordance with BHEL standard AA0851711: Test Methods for Insulation Coating on Magnetic Steel Sheets, shall show the following properties:

8.6.1 Selection of Test Samples for Insulation Coating

The outermost and innermost turn of coil or the topmost and bottommost of a stack of sheets, shall be considered as wrapping and not representing the properties of the remaining material and hence shall not be considered for test specimen.

In case of coils, the test specimens shall be preferably taken from the first external turn excluding the wrapping turn and in case of sheet, it shall be from the upper part of the stack. In special case, it can be taken from any other part also.

The test specimen shall extend over the entire sheet width and can be about 350 ± 2mm long. In case of sheet width, below 400mm, the specimen shall be 500 ± 2mm long.

The surface of the strip shall be free from contaminations & damages and shall be cut without deformation and as far as possible, without burrs. Any cleaning done shall not damage the insulation coating.

8.6.2 Coating Layer Thickness

Both sides of the sheet shall be coated and shall have an average thickness of 5.5±1.5 microns on each side. At least 15 readings shall be taken on each side at equal intervals. None of the readings should be below 2.0 microns.

The thickness of any pre-coating shall not be accounted for.

8.6.3 Surface insulation Resistivity

The minimum average of 10 non-overlapping resistance measurements (5 on each side) shall be 30 ohm-cm² with a minimum allowable individual value of 10 ohm-cm².



8.6.4 Type Tests

8.6.4.1 Adherence Test

The surface coating shall be sufficiently adherent so that it does not get detached during insulation and shearing. In the reverse bending test with a bending radius of 5mm, the surface coating shall not be detached after bending through 90°.

8.6.4.2 Thermal Effect on Coating

The limiting temperature of the insulation shall be 155±3°C (Class B).

8.6.4.3 Resistance to Solvents, Oils & Ammonia

The insulation film shall be resistant to conventional organic solvents like trichloroethylene, methylated spirit, acetone, benzene, and oil. In special cases and when specified on BHEL order, the insulating film shall be resistant to ammonia also.

* Note

'Type tests' shall be carried out when, 'Type Approval' to a supplier is given and repeated once in five years for the approved supplier.

9 TEST CERTIFICATES

Three copies of test certificates shall be supplied, unless otherwise specified on order.

In addition, the supplier shall ensure to enclose one copy of the test certificate along with their despatch documents to facilitate quick clearance of the material.

The test certificate shall bear the following information

AA10917-Rev 07 / IS 648; Gr: 50C530/Gr: 65C530/EN 10106; Gr: M530-50A/Gr: M530-65A/
ASTM A 677

BHEL Order No.

Supplier's Name/Grade/Identification No.

Size & Weight

Melt No., Packet/Bundle No.

Test results of

- a) Dimensions & Tolerances
- b) Properties as per the concerned National standards & insulation coating, as above.

10 PACKING AND MARKING

10.1 Material Supplied in Straight Length

Magnetic steel sheets shall be supplied in bundles. The packing shall be seaworthy and shall protect the material from damage during transit. A typical packing which would be suitable is shown below.

Each sheet shall be marked with supplier's grade/references.

These markings shall be along the rolling direction.

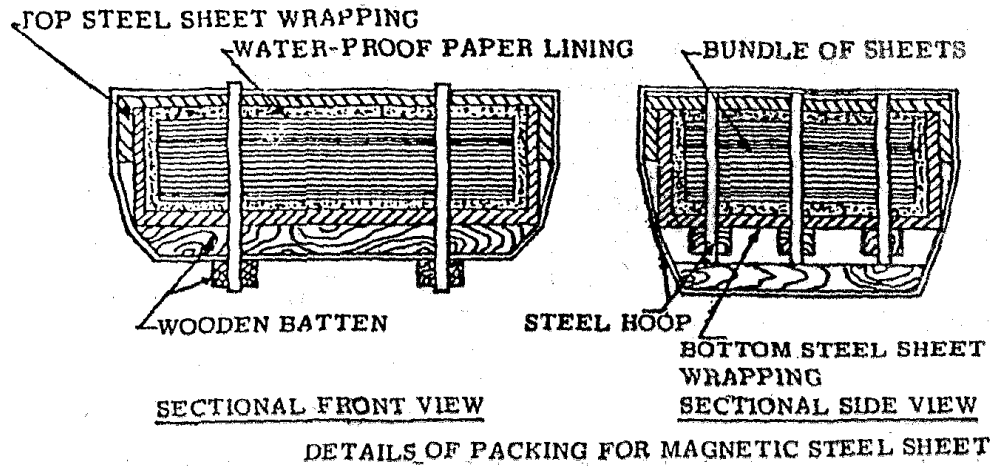

Note:

- a) Water proof paper lining shall be preferably Volatile Corrosion Inhibitor (V.C.I) Coated Paper with an additional polythene (100 micron) enveloped.
- b) Approximate weight of each bundle shall be 2 to 3 metric tonnes. Bundle weighing 2 Metric tonnes is however preferred.
- c) The packing should ensure that there is no seepage of moisture and the sheets reach BHEL on completely rust free condition. It shall be strong enough to withstand handling at the docks, at sea on the road.

10.2 Material Supplied in Continuous Coil

The nominal weight of each coil shall be 1800-2000kg.

The nominal internal diameter of coil shall be 508mm.

Packing shall be sea-worthy and shall protect the coils from damage and rusting during transit. The supplier's grade /reference shall be marked at every one metre intervals throughout the coil length.

Coils shall be vertically packed according to the instructions and drawing given below:

- a) An annular protection board shall be placed at either end of coil.
- b) The coil shall then be wrapped with waterproof anti-rust proof by lapping axially all around the circumference.
- c) The coil shall then be covered by polyethylene sheet or anti-rust waterproof paper and the ends sealed properly.
- d) A galvanized sheet shall be wrapped on the outside of the coil and the top and bottom of the coils. Care shall be taken to ensure that the ends of the top and bottom of the coils extend sufficiently over the inside diameter of the coil.
- e) A galvanised sheet shall be wrapped on the inside of the coil. Care shall be taken that it overlaps sufficiently over the ends of the sheet mentioned in (d) above.
- f) Steel ring made from thick angle sheets shall be placed on the rim of the inner diameter at both ends of the coil. The rings shall be held at either ends at four points by steel bands.
- g) The coil should then be mounted on wooden skids held together by steel bands. Wooden skids must have cutouts to house the steel bands for tight fit and to avoid slippage.
- h) The packing shall ensure that there is no seepage of moisture and the coils reach BHEL in completely rust free condition. It shall be strong enough to withstand handling.

- i) Coils shall be sufficiently tight-wound to prevent collapse to an extent that would preclude their being mounted on a mandrel appropriate to the ordered internal diameter.
- j) Each package should indicate the Sling Position, for lifting without damage. It is preferable to fix a suitable size of, 'Sheet Steel Angle', at the position where the Sling Rope is to be fitted to avoid slippage/damage/breakage of the wooden skid at four places.

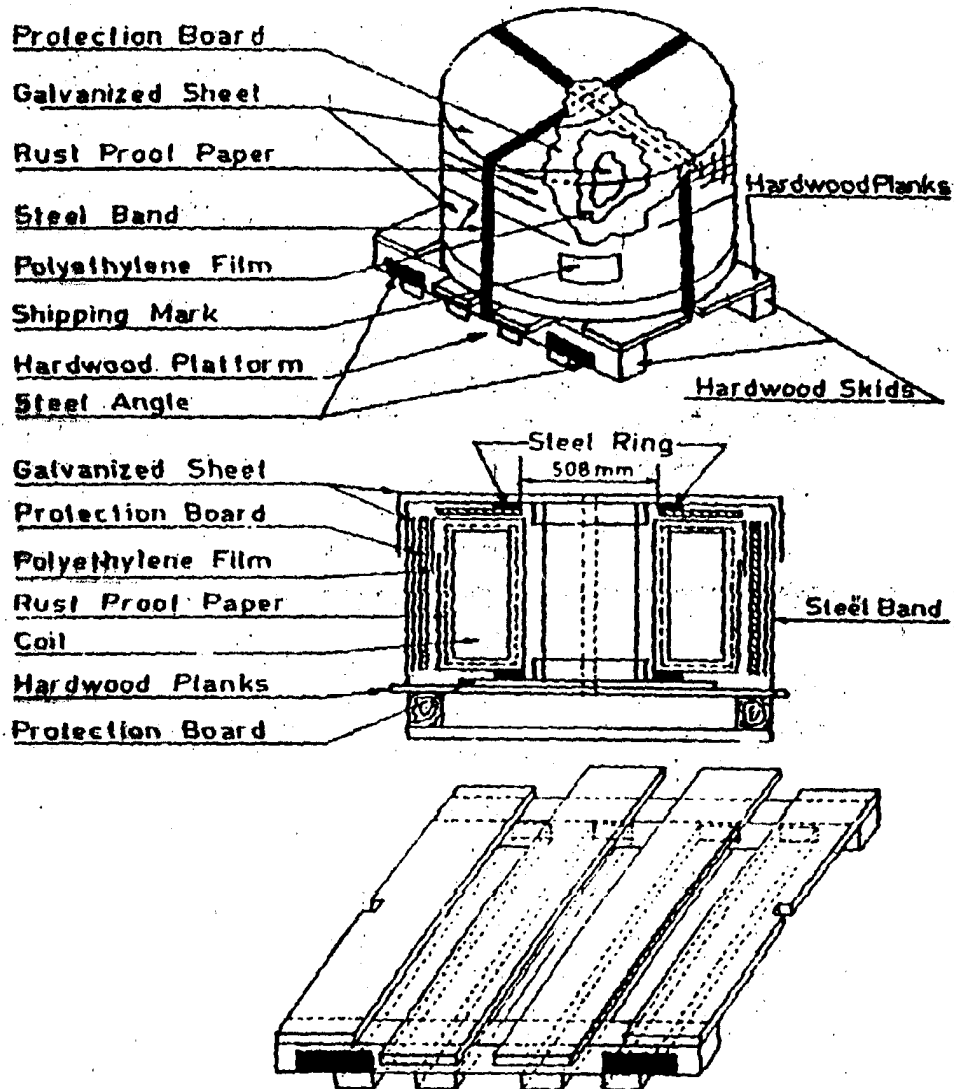

10.3 Marking

A metal label/tag shall be securely attached with each bundle outside its wrapping and shall be legibly marked with the following information.

AA10917

BHEL Order No.

Supplier's Name/Grade/Identification No.

Size & Weight

Melt No., Packet/Bundle No.



CORPORATE PURCHASING SPECIFICATION

AA10917

Rev No. 07

PAGE 9 of 9

11 REFERRED STANDARDS (Latest Publications Including Amendments)

- 1) AA0851711
- 2) AA27541
- 3) IS 649
- 4) AISI C-6
- 5) ASTM A 677

GENERAL INFORMATION FOR CALCUALTION (NOT MANDATORY/TYPICAL VALUES)

| | |
|--------------------------------------|--|
| Density | : 7.7 kg/cm ³ |
| Total specific loss at 1.0 Tesla | : 1.50 watts/kg for 0.50mm and 0.65mm thick |
| Magnetic induction (B) at 30,000 A/m | : 1.97 Tesla, min – 0.5mm, thick |
| Magnetic field Strength (H) (Peak) | : 1.97 Tesla, min – 0.65mm, thick |
| Total specific loss at 1.0 Tesla | : 2.30 watts/kg, max for 0.50mm & 0.65mm thick |

Mechanical Properties:

| | |
|---------------------------------------|-------------------------|
| Tensile strength | : 430 N/mm ² |
| Yield strength | : 290 N/mm ² |
| Elongation on 5.65 √S ₀ GL | : 30% |



TSD 6206A

PLANT PURCHASING SPECIFICATION BHOPAL

BP 10976

REV NO. 00

PAGE 1 of 4

MAGNETIC STEEL SHEET-COLD ROLLED GR. 250

1.0 GENERAL:

This specification gives the quality requirements of high permeability magnetic steel sheet cold rolled, having a minimum 0.2% proof value of 250 N/mm².

2.0 APPLICATION:

Pole Laminations of Hydro Generators / Lift Irrigation Motors.

3.0 CONDITION OF DELIVERY:

Cold Rolled with trimmed edges in straight lengths (sheet form) in the ordered thickness & size as specified on BHEL order.

Material shall be supplied coated with rust preventive oil coating on both sides and shall not contain any welds. The sheets shall be stacked so that their edges are superimposed in a regular manner.

4.0 DIMENSIONS AND TOLERANCES:

4.1 **Sizes:** Magnetic steel sheet shall be supplied to the dimensions specified on BHEL order.

The thickness shall preferably be selected from the following standard sizes 0.8/1.00 mm. Sheets shall be supplied in straight lengths & shall be flat & edges cleanly sheared & truly squared.

4.2 Tolerances:

4.2.1 Thickness:

| Nominal Thickness (mm) | | Permitted thickness tolerances for widths (mm) |
|------------------------|------|--|
| Above | Upto | Upto 1250 |
| 0.8 | 1.0 | +/-0.05 |

Issued by :

STANDARDS AND MATERIALS GROUP
TECHNICAL SERVICES DEPARTMENT

Rev. 00

Date : 30-04-2024

Date of first issue: April 2024

4.2.2 Width (Trimmed Edges)

| Width (mm) | | Permitted Width tolerances (mm) | |
|------------|------|---------------------------------|-------|
| From | Upto | Plus | Minus |
| - | 1250 | 7 | 0 |
| 1250 | 2000 | 10 | 0 |

4.2.3 Length:

| Length (mm) | Permitted length tolerances | |
|-------------|-----------------------------|-------|
| | Plus | Minus |
| Upto 2000 | 15 mm | 0 |
| Above 2000 | 0.75% of length | 0 |

4.2.4 Flatness:

The maximum distance between the lower face of the sheet and the flat horizontal surface shall not exceed the values given below;

| Length (mm) | Maximum distance for nominal thickness (mm) |
|----------------|---|
| Less than 1250 | 8 |
| 1250 & above | 10 |

4.2.5 Edge Camber:

The gap which characterizes the edge camber shall not exceed $0.4\% \times$ Length of the sheet for material supplied with trimmed edges.

5.0 FREEDOM FROM DEFECTS:

The surface of the material, before application of rust preventive oil coating shall be smooth and clean, free from grease, rust, loose scale and other surface defects such as burrs, cutting distortions, dents, waviness, scratches, blisters, cracks, pitting, cracked edges etc.



PLANT PURCHASING SPECIFICATION BHOPAL

BP 10976

REV NO. 00

PAGE 3 of 4

6.0 TEST SAMPLES:

One bend test and one hardness test shall be carried out from each lot of material or part thereof, per melt per consignment.

Where materials of more than two thicknesses are rolled from the same melt, one additional bend test shall be made for each thickness.

Test pieces shall be out so that the axis of the bend is parallel to the direction of rolling i.e. bending shall be in perpendicular direction of rolling.

7.0 PROPERTIES:

The material, when tested as detailed in BS EN 10265 at a temperature of 27+/-2 °C shall show the following properties:

7.1 Mechanical:

Tensile Strength : 350-450 N/mm²
0.2% Proof Stress : 250 N/mm² minimum
Elongation on 80 mm Gauge length : 22% minimum

7.2 Magnetic:

The material when tested on a Epstein frame at an AC Magnetic field in amperes/meter shall show the following minimum corresponding value of magnetic flux density in Tesla.

| Magnetic field strength (A/m) | Minimum Magnetic flux Density (Tesla) |
|--------------------------------|---------------------------------------|
| 5000 | 1.6 (For information) |
| 15000 | 1.8 (Guaranteed) |

8.0 TEST CERTIFICATE:

Three copies of Test Certificate shall be supplied unless otherwise agreed to.

In addition, the supplier shall ensure to enclose one copy of the test Certificate along with their dispatch documents, to facilitate quick clearance of the material.

The test certificate shall bear the following information:

Material grade, BHEL Order No, Supplier's Name/Grade/Identification No., Size & Weight, Packet/Bundle No, Test Results of – a) Dimensions & Tolerances, b) Mechanical Properties & c) Electromagnetic properties viz: Magnetic Flux Density in Tesla – Guaranteed at 15000 A/m & For information at 5000 A/m and B.H. Curve from 0 to 15000 A/m.



PLANT PURCHASING SPECIFICATION BHOPAL

BP 10976

REV NO. 00

PAGE 4 of 4

9.0 PACKING AND MARKING:

9.1 Packing:

Magnetic steel sheets shall be supplied in bundles. The packing shall be sea worthy and shall protect the material from damage in transit. Proper supports are to be provided to avoid bulging/ distortion of the sheets.

Each sheet shall be marked with supplier's grade/ references. These markings shall be along the rolling direction.

NOTE :

- a) Water proof paper lining shall be preferably volatile corrosion inhibitor (V.C.I.) coated paper with additional polythene (100 micron) enveloped.
- b) Approximate weight of each bundle shall be 2 to 3 metric tonnes. Bundle weighing 2 metric tonnes is however preferred.
- c) The packing shall ensure that there is no seepage of moisture and the sheets reach BHEL in completely rust free condition. It shall be strong enough to withstand handling at the docks, sea and on the road.

9.2 Marking:

A metal label/tag shall be securely attached with each bundle, outside its wrapping and shall be legibly marked with the following information:

BHEL Order No, Supplier's Name / Grade / Identification No, size & weight, Melt No, Packet / Bundle No.

NOTE FOR COMPLIANCE WITH STANDARDS: Refer HGE product standard HG10067 Rev-01.



**PLANT PURCHASING SPECIFICATION
BHOPAL**

BP 10978

REV NO. 00

PAGE 1 of 4

**MAGNETIC STEEL SHEET – COLD ROLLED
GR. 600**

1) GENERAL:

This specification governs the quality requirements of high permeability magnetic steel sheet cold rolled, having a minimum 0.2% Proof Stress value as shown below:

| GRADE | 0.2% Pr. STRESS |
|-------|----------------------------|
| 600 | 600 N/mm ² Min. |

2) APPLICATION:

Rim Lamination of Hydro Generators

3) CONDITION OF DELIVERY:

Cold Rolled with trimmed edges in straight lengths (sheet form) in the ordered thickness & size as specified on BHEL order.

Material shall be supplied coated with rust preventive oil coating on both sides, and shall not contain any welds. The sheets shall be stacked so that their edges are superimposed in a regular manner.

4) DIMENSIONS AND TOLERANCES:

4.1 Sizes:

Magnetic steel sheet shall be supplied to the dimensions specified on BHEL order. The thickness shall preferably be within the range of 1.5 mm to 4.5 mm. Sheets shall be supplied in straight lengths & shall be flat & edges cleanly sheared & truly squared

Issued by :

**STANDARDS AND MATERIALS GROUP
TECHNICAL SERVICES DEPARTMENT**

Rev. 00

Date : 22.04.2024

Date of first issue: April 2024

The information on this document is the property of Bharat Heavy Electricals Limited,
It must not be used directly or indirectly in any way detrimental to be interest of the company

4.2 Tolerances:

4.2.1 Thickness:

| Nominal Thickness (mm) | | Permitted thickness tolerances for widths (mm) | |
|------------------------|-------|--|--|
| Above | Up to | Up to 1250 | |
| 1.5 | 2.0 | +/- 0.10 | |
| 2.0 | 3.0 | +/- 0.15 | |
| 3.0 | - | +/- 0.20 | |

4.2.2 Width (Trimmed Edges)

| Width (mm) | | Permitted Width tolerances (mm) | |
|------------|------|---------------------------------|-------|
| From | Upto | Plus | Minus |
| - | 1250 | + 7 | 0 |
| 1250 | 2000 | + 10 | 0 |

4.2.3 Length:

| Length (mm) | | Permitted Length tolerances (mm) | |
|-------------|--|----------------------------------|-------|
| | | Plus | Minus |
| Up to 2000 | | 15 | 0 |
| Above 2000 | | 0.75% of length | 0 |

4.2.4 Flatness:

The maximum distance between the lower face of the sheet and the flat horizontal surface shall not exceed the values given below:

| Length (mm) | Maximum distance for nominal thickness |
|----------------|--|
| Less than 1250 | 8 |
| 1250 & above | 10 |

4.2.5 Edge Camber:

The gap which characterizes the edge camber shall not exceed 0.4% x Length of the sheet for material supplied with trimmed edges and above 150 mm width.

5) FREEDOM FROM DEFECTS:

The surface of the material shall be smooth and clean, free from grease, rust, loose scale and other surface defects such as burrs, cutting distortions, dents, waviness, scratches, blisters, cracks, pitting, cracked edges etc.

6) PROPERTIES:

The material, when tested as detailed in BS EN 10265 at a temperature of 27 ±2 deg. C shall show the following properties:

6.1 Mechanical:

| | |
|------------------------------------|----------|
| GRADE | 600 |
| TENSILE STRENGTH N/mm ² | 700-850 |
| 0.2% PR STRENGTH N/mm ² | 600 Min. |
| %EL ON 80 mm GAUGE LENGTH | 8 Min. |

7) Magnetic:

The material when tested on a Epstein frame at an AC magnetic field in amperes / meter shall show the following minimum corresponding value of magnetic flux density in Tesla.

| Magnetic Field Strength A/m | Magnetic Flux Density Tesla (Minimum) |
|--------------------------------|--|
| | Grade 600 |
| 5000 For information | 1.5 |
| 15000 Guaranteed | 1.78 |



PLANT PURCHASING SPECIFICATION BHOPAL

BP 10978

REV NO. 00

PAGE 4 of 4

8) TEST CERTIFICATE:

Three copies of Test Certificate shall be supplied unless otherwise agreed to. In addition, the supplier shall ensure to enclose one copy of the Test Certificate along with their dispatch documents, to facilitate quick clearance of the material.

The test certificate shall bear the following information:

Material grade, BHEL Order No, Supplier's Name/Grade/Identification No., Size & Weight, Packet/Bundle No, Test Results of – a) Dimensions & Tolerances, b) Mechanical & c) Electromagnetic properties viz: Magnetic Flux Density in Tesla – Guaranteed at 15,000 A/m and For Information at 5000 A/m and B.H. Curve from 0 to 15000 A/M.

9) PACKING AND MARKING:

9.1 Packing:

Magnetic steel sheets shall be supplied in bundles. The packing shall be sea-worthy and shall protect the material from damage in transit. Proper supports are to be provided to avoid bulging/distortion of the sheets.

Each sheet shall be marked with supplier's grade / references. These markings shall be along the rolling direction.

Note:

Water proof paper lining shall be preferably Volatile Corrosion Inhibitor (V.C.I.) Coated Paper with an additional polythene (100 micron) enveloped.

Approximate weight of each bundle shall be 2 to 3 metric tons. Bundle weighing 2 metric tons is however preferred.

The packing shall ensure that there is no seepage of moisture and the sheets reach BHEL in completely rust free condition. It shall be strong enough to withstand handling at the docks, at sea and on the road.

9.2 Marking:

A metal label / tag shall be securely attached with each bundle, outside its wrapping and shall be legibly marked with the following information:

BHEL Order No,
Supplier's Name / Grade / Identification No,
size & Weight,
Melt No,
Packet / Bundle No.



TSD6206A

**PLANT PURCHASING SPECIFICATION
BHOPAL**

BP 10982

REV NO. 00

PAGE 1 OF 10

SPECIFICATION FOR COLD ROLLED NON-GRAIN ORIENTED SHEET STEEL
GRADE – 235-35A, 270-35A, 270-50A, 290-50A, 350-50A, 600-65A**1.0 GENERAL:**

This specification governs the technical & quality requirements of insulated (double side) & Un-Insulated cold rolled, non-grain oriented magnetic steel sheet or coil in finally annealed condition in 0.35 , 0.5 , 0.65 thicknesses.

2.0 APPLICATION:

Stator Laminations of Hydro generators / Motors & Electrical Machines etc.

3.0 Condition of Delivery:

3.1 Cold rolled, finally annealed.

3.2 The material shall be supplied in straight lengths (sheet form) or in coils, to the ordered thickness as specified in BHEL order

3.3 Magnetic steel sheets or coils shall be supplied with or without insulation coating, as detailed below, and as called for on BHEL order.

a) 0.35 mm , 0.5 mm thick - Insulated:*

Both side insulated with an average of 5 ± 1.5 micron thickness coating on each side with varnish as per BHEL specification AA27541. The Insulation thickness of any individual point shall lie between 3.5 to 9 microns & points shall be uniformly distributed.

b) 0.65 mm Thick - Uninsulated:

Un-insulated, protected on both sides by rust preventive oil coating.

***Note:**

(i) The supplier shall furnish the details of such coatings alongwith the quotation (For insulation coating, these details shall be furnished as per Annexure-1 of BHEL standard AA 0851711) for approval of BHEL prior to the first time supply and/or as when the type of coating is changed subsequently with the prior approval of BHEL.

(ii) The surface finish of the material shall be such as to allow subsequent uniform varnishing, without any problem.

Issued by :

STANDARDS AND MATERIALS GROUP
TECHNICAL SERVICES DEPARTMENT

Rev. 00

Date : 01.09.2023

Date of first Issue: SEPTEMBER 2023

CONFIDENTIAL AND CONFIDENTIAL
The information on this document is the property of Bharat Heavy Electricals Limited,
It must not be used directly or indirectly in any way detrimental to be interest of the company

3.4 Type Of Insulation Coating:

The insulation coating used for the insulated steel sheets referred in clause 3.3 (a) above shall be uniformly applied, tightly adherent and shall be as per BHEL specification AA 27541 or as per AISI, C-6 of the filler base type on both sides, pigmented varnish coating (in which case it shall be compatible to varnish as per AA 27541) and shall meet the requirements detailed in Clause 8.6.

Supplier to inform the Type, Grade & Source of actual varnish used to confirm the compatibility with BHEL varnish system.

4.0 COMPLIANCE WITH NATIONAL STANDARDS:

Material shall comply with the requirements of the national standards as given in following table-1 and also meet the requirements of this specification. Material offered to IEC or DIN as per following table-1 is also acceptable.

| TABLE-1 COMPLIANCE WITH OTHER STANDARDS & EQUIVALENT GRADES | | | | |
|---|----------------------|-----------------------------------|--|--|
| S. No. | BHEL Specified grade | Equivalent material as per IS 648 | Equivalent material as per IEC 60404-8-4 | Equivalent material as per DIN EN10106 |
| 1 | 235-35A | 35C235 | M235-35A * | M235-35A |
| 2 | 270-35A | 35C270 | M270-35A* | M270-35A |
| 3 | 270-50A | 50C270 | M270-50A * | M270-50A |
| 4 | 290-50A | 50C290 | M290-50A * | M290-50A |
| 5 | 350-50A | 50C350 | M350-50A * | M350-50A |
| 46 | 600-65A | 65C600 | M600-65A * | M600-65A |

* - 5 FOR 50 Hz and 6 for 60 Hz

5.0 DIMENSIONS AND TOLERANCES:

5.1 Sizes:

Magnetic steel sheet shall be supplied to the dimensions and coatings specified on BHEL order.

5.2 Tolerances:

5.2.1 Thickness:

The permissible deviation in nominal thickness shall be $\pm 8\%$. The variation in thickness in a direction parallel to the direction of rolling shall not exceed $\pm 8\%$ of the nominal thickness.

The variation in thickness in a direction perpendicular to the direction of rolling shall be ± 0.020 mm for nominal thickness of 0.5 & 0.35 mm and ± 0.030 mm for 0.65mm thick. The measuring points should be at least 40 mm away from the edges of the sheets.

5.2.2 Width:

The tolerance for width of material supplied with trimmed edges shall be as follows.

| Width (mm) | | Tolerance (mm) | |
|------------|------------------|----------------|-----------|
| Over | Up to & included | + (plus) | - (Minus) |
| - | 150 | 0.3 | 0 |
| 150 | 500 | 0.5 | 0 |
| 500 | 1250 | 1.5 | 0 |

5.2.3 Length:

When supplied in sheet form, the tolerance on length shall be + 1%, but shall not exceed + 10 mm/ - 0 mm.

5.2.4 Straightness/Edge Camber:

The straightness tolerances for the longitudinal edge (edge camber "C") over a gauge length of 2000 mm shall not exceed 4 mm for width "W" upto and including 150 mm and 2 mm for widths exceeding 150 mm.

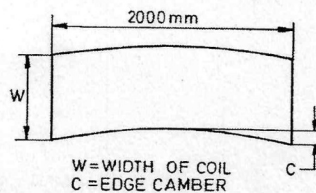

5.2.5 Edge Burr:

The height of edge burr shall not exceed 50 microns.

5.2.6 Bowing - Coils:

The material when unwound from a coil shall be placed flat on a level smooth surface (surface plate) such that it has a radius not less than 3000 mm. The specimen should be stood upright and free from constraint with one longitudinal edge on the surface of the plate. A straight edge with a length of 500 mm, when placed against the specimen and when measuring the greatest distance 'h' between the straight edge and the product should not be more than 10 mm as detailed below:

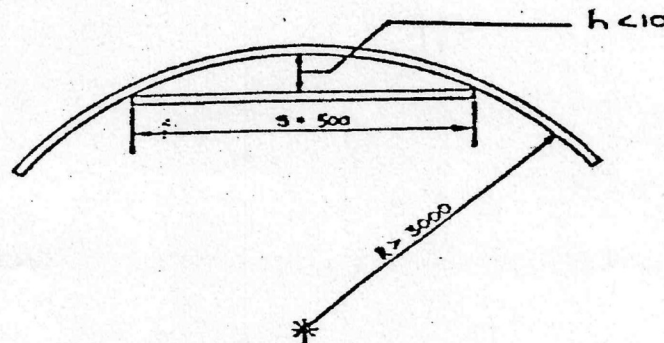

NOTE: Any other method as per IEC 60404-9 /DIN EN standard is also acceptable with approval of BHEL.

5.2.7 Waviness/Flatness

The Waviness/Flatness shall not exceed 1.5% (i.e the ratio of the wave height to wave length).

6.0 FINISH:

The material shall have a smooth surface and shall be free from loose scale, buckle or dents, waviness and internal stresses.

7.0 TEST SAMPLES:

The test samples of the same heat/melt & thickness shall be selected from the consignment as follows:

Upto 30 tonnes : 1 sample

Above 30 to 60 tonnes : 2 samples

Above 60 tonnes : 3 samples

The test samples shall be sufficient in size to provide the necessary test pieces.

8.0 PROPERTIES (AS RECEIVED):

Table 3 – Technological properties and magnetic properties

| S. No. | Grade | Thickness (mm) | Maximum Total Specific Loss (W/Kg) (For 50 Hz) | | Minimum magnetic polarization in an alternating magnetic field for a magnetic field strength (Tesla) | | | Maximum Anisotropy of losses (%) | Minimum Stacking Factor / No. of test pieces for stacking factor | No. of Bends | Density Kg/dm ² (Informative) |
|--------|---------|----------------|--|------------------------|--|----------|-----------|----------------------------------|--|--------------|--|
| | | | 1.0 Tesla (Informative) | 1.5 Tesla (Guaranteed) | 2500 A/m | 5000 A/m | 10000 A/m | | | | |
| 1 | 235-35A | 0.35 | 0.95 | 2.35 | 1.49 | 1.6 | 1.7 | ±17 | 0.93 / 20 | 2 | 7.60 |
| 2 | 270-35A | 0.35 | 1.1 | 2.7 | 1.49 | 1.6 | 1.7 | ±17 | 0.93 / 20 | 2 | 7.65 |
| 3 | 270-50A | 0.50 | 1.10 | 2.70 | 1.49 | 1.6 | 1.7 | ±17 | 0.95 / 16 | 2 | 7.60 |
| 4 | 290-50A | 0.50 | 1.15 | 2.9 | 1.49 | 1.6 | 1.7 | ±17 | 0.95 / 16 | 2 | 7.60 |
| 5 | 350-50A | 0.50 | 1.50 | 3.50 | 1.5 | 1.6 | 1.7 | ±12 | 0.95 / 16 | 5 | 7.65 |
| 6 # | 600-65A | 0.65 | 2.60 | 6.0 | 1.56 | 1.66 | 1.76 | ±10 | 0.97 / 16 | 10 | 7.75 |

NOTE :

- 1- Item at S. No. 6 marked with (#) shall be used for Spacer plate only.
- 2- For Total specific loss for 60 Hz machines IEC 60404-8-4 Table-1 shall be referred.

8.1 Bend Test:

When tested to IS 649/IEC 60404-8-4, test piece shall withstand minimum number of bends, as specified in Table-3, without fracture, through 180 degrees over a 5 mm radiused jaws.

8.2 Stacking Factor:

The surface quality of the sheets when measured in terms of stacking factor as per IS 649 / IEC 60404-8-4 for 0.35mm/0.5mm thick double side coating (insulated) and 0.65 mm thick uninsulated steel sheet shall give values as mentioned in Table-3.

8.3 Total Specific Loss:

The total specific loss on aged specimens (a specimen which has been heated for 24 hours at 225 ± 3 °C) shall be as per Table-3, when tested as per IS:649 / IEC 60404-2.

8.4 AC Magnetisation:

When tested to IS 649 / IEC 60404-2, the AC magnetic field (H) in Ampere/metre (Peak), shall show minimum corresponding values of magnetic induction (B) in Tesla (Peak) as per Table-3.

8.5 Anisotropy of Losses:

When tested to IS 649 / IEC 60404-8-4 as detailed below, the Anisotropy of losses shall not exceed the values mentioned in Table-3.

To determine the loss ANISOTROPY the specific total loss at 1.5T & 50 Hz should be measured separately on specimens taken parallel and perpendicular to the rolling direction. The loss Anisotropy, in percent, is found from the following expression:

$P_q - P_1$

———— x 100 where,

$P_q + P_1$

P_q denotes specific total losses perpendicular to the rolling direction.

P_1 denotes the specific total losses parallel to the rolling direction.

8.6 Testing Of Insulation Coating:

The insulation coating when tested with BHEL standard AA0851711 : Test methods for insulation coating on magnetic steel sheets, shall show the following properties :

8.6.1 Selection Of Test Samples For Insulation Coating:

The outermost and innermost turn of coil or the top-most and bottom-most of a stack of sheets, shall be considered as wrapping and not representing the properties of the remaining material and hence shall not be considered for test specimen.

In case of coils, the test specimens shall preferably taken from the first external turn excluding the wrapping turn and in case of sheet, it shall be from the upper part of the stack. In special case, it can be taken from any other part also.

The test specimen shall extend over the entire sheet width and can be about 350 ± 2 mm long. In case of sheet width, below 400 mm, the specimen shall be 500 ± 2 mm long.

The surface of the strip shall be free from contaminations and damages and shall be cut without deformation and as far as possible, without burrs. Any cleaning done shall not damage the insulation coating.

8.6.2 Coating Layer Thickness:

Both sides of the sheet shall be coated and shall have average thickness of 5 ± 1.5 micron on each side. At least 15 readings shall be taken on each side at equal intervals. 80% of the readings shall lie between the above specified values.

8.6.3 Surface Insulation Resistivity:

When tested as per ASTM, A 717 - Franklin's Method, at a pressure of 2 N/mm^2 , at room temperature. The minimum average of 10 non-overlapping resistance measurements (5 on each side) shall be 30 Ohm-cm^2 with a minimum allowable individual value of 10 Ohm-cm^2 .

NOTE: Any other method is also acceptable with approval of BHEL.

8.6.4 Type Tests*:

8.6.4.1 Adherence Test:

The surface coating shall be sufficiently adherent so that it does not get detached during insulation and shearing. In the reverse bending test with a bending radius of 5 mm, the surface coating shall not be detached after bending through 90° .



PLANT PURCHASING SPECIFICATION BHOPAL

BP 10982

REV NO. 00

PAGE 7 OF 10

8.6.4.2 Thermal Effect On Coating:

Twelve specimens of the coated strip shall be clamped together under a pressure of 1 N/mm² approximately and heated in a laboratory oven at a temperature of 150±3 °C for a period of 7 days. After cooling to room temperature, the surface insulation resistivity values of the middle ten specimens shall not be less than the minimum specified values mentioned in cl.8.6.3.

8.6.4.3 Resistance to Solvents & Oils:

The specimens shall be kept in a container filled with any of the following solvents/oil and boiled for 5 minutes. After removal and cooling to the room temperature, the coating shall not get soft enough so that it can be wiped off. The insulation film shall be resistant to conventional organic solvents like trichloroethylene, methylated spirit, acetone, benzene, etc. and oil. In special cases and when specified on BHEL order, the insulating film shall be resistant to ammonia also.

*Note:

'Type tests', shall be carried out when, 'Type Approval', to a supplier is given & repeated once in 5 years for the approved supplier.

9.0 TEST CERTIFICATES:

Three copies of Test Certificates shall be supplied unless otherwise specified on order. In addition, the supplier shall ensure to enclose one copy of the Test Certificate along with their despatch documents to facilitate quick clearance of the material.

The test certificate shall bear the following information:

BP10982; Gr: (As per BHEL Order), BHEL Order No, Suppliers Name & Grade/ Identification No, Size & Weight, Melt No., Packet/Bundle No. Test Results of Dimensions & Tolerances, Properties as per the concerned National Standard & Insulation Coating, as above. Also type test certificates, not older than 5 years, shall be submitted along with each consignment.

Loss curve, magnetization curve catalogue of specified grade shall be submitted.

10.0 PACKING AND MARKING:

10.1 Material Supplied In Straight Length (sheet) :

Magnetic steel sheets shall be supplied in bundles. The packing shall be seaworthy and shall protect the material from damage during transit. A typical packing which would be suitable is shown below.

Each sheet shall be marked with supplier's grade/references.

These markings shall be along the rolling direction.

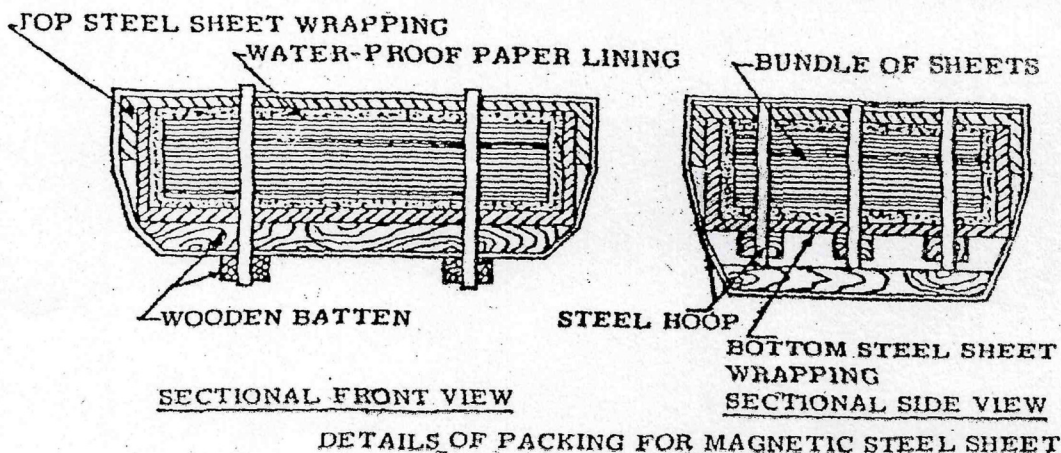

Note:

- a) Water proof paper lining shall be preferably Volatile Corrosion Inhibitor (V.C.I.) Coated Paper with an additional polythene (100 micron) enveloped.
- b) Approximate weight of each bundle shall be 2 to 3 metric tonnes. Bundle weighing around 2.5 metric tonnes is however preferred.
- c) The packing should ensure that there is no seepage of moisture and the sheets reach BHEL in completely rust free condition. It shall be strong enough to withstand handling at the docks, at sea and on the road.

10.2 Material Supplied In Continuous Coil:

The nominal weight of each coil shall be around 2500 kg.

The nominal internal diameter of coil shall be around 500 mm.

Packing shall be sea-worthy and shall protect the coils from damage and rusting during transit.

The supplier's grade/reference shall be marked at every one metre intervals throughout the coil length.

Coils shall be vertically packed according to the instructions and drawing given below.

- a) An annular protection board shall be placed at either end of coil.
- b) The coil shall then be wrapped with waterproof anti-rust proof paper by lapping axially all around the circumference.
- c) The coil shall then be covered by polythene sheet or anti-rust waterproof paper and the ends sealed properly.
- d) A galvanised sheet shall be wrapped on the outside of the coil and the top and bottom of the coils. Care shall be taken to ensure that it covers the top and bottom of the coils and extend sufficiently over the inside diameter of the coil.

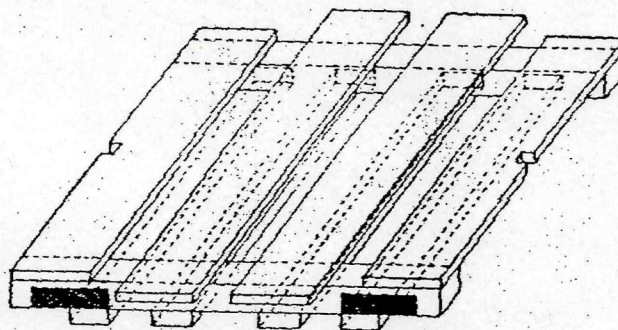
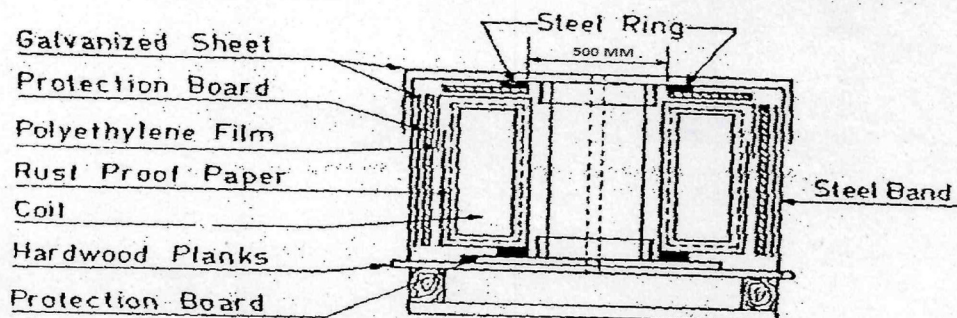
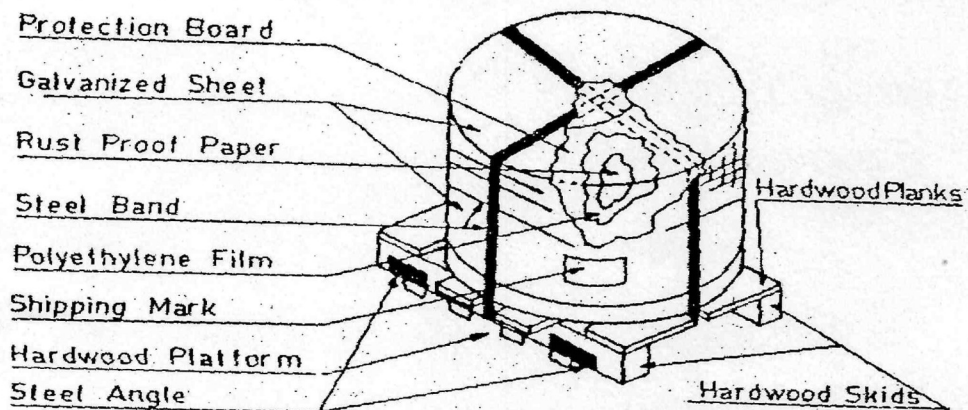

- e) A galvanised sheet shall be wrapped on the inside of the coil. Care shall be taken that it overlaps sufficiently over the ends of the sheet mentioned in (d) above.
- f) Steel ring made from thick angle sheets shall be placed on the rim of the inner diameter at both ends of the coil. The rings shall be held at either ends at four points by steel bands.
- g) The coil shall then be mounted on wooden skids held together by steel bands. Wooden skids must have cutouts to house the steel bands for tight fit and to avoid slippage.
- h) The packing shall ensure that there is no seepage of moisture and the coils should reach BHEL in completely rust free condition. It shall be strong enough to withstand handling at the docks, at sea and on the road.
- i) Coils shall be sufficiently tight-wound to prevent collapse to an extent that would preclude their being mounted on a mandrel appropriate to the ordered internal diameter.
- j) Each package should indicate the, Sling Position₂ for lifting without damage. It is preferable to fix a suitable size of, 'Sheet Steel Angle', at the position where the Sling Rope is to be fitted to avoid slippage/damage/breakage of the wooden skid at four places.



PLANT PURCHASING SPECIFICATION BHOPAL

BP 10982

REV NO. 00

PAGE 10 OF 10

10.3 Marking:

A metal label / tag shall be securely attached with each bundle outside its wrapping and shall be legibly marked with the following information.

BP10982, BHEL Order No, Supplier's Name & Grade, Identification No, Size & Weight, Melt No, Packet/Bundle No.

11.0 REFERRED STANDARDS (Latest Publications Including Amendments) :

- | | | | |
|------------------|-----------------|---------------|------------|
| 1) AA 0851711 | 2) AA 27541 | 3) IS 648 | 4) IS 649 |
| 5) IEC 60404-8-4 | 6) IEC 60404-2 | 7) ASTM A 717 | 8) AISI C6 |
| 9) DIN EN 10106 | 10) IEC 60404-9 | | |

12. GENERAL INFORMATION FOR CALCULATION

(NOT MANDATORY / TYPICAL VALUES)

Mechanical Properties(Typical)

| | | |
|------------------------------|---|-----------------------|
| Density | : | As per Table-3 |
| Tensile strength | : | 530 N/mm ² |
| Yield strength | : | 400 N/mm ² |
| Elongation on (5.65 √ So GL) | : | 18% |



CORPORATE STANDARD

AA 085 17 11

REV.No. 00

PAGE 1 OF 5

TEST METHODS FOR INSULATION COATING ON MAGNETIC STEEL SHEETS

1. GENERAL:

This standard stipulates the test methods for insulation (varnish) coating on magnetic steel sheets. These test methods are applicable for the finished varnish coating applied by the manufacturer before processing the magnetic steel sheets.

The test results shall be furnished in the test certificate formate as per DIN 50049, given in Annexure I.

2. VARNISH COATING:

The type and thickness of insulation coating shall conform to the respective purchase specification of magnetic steel sheets.

3. PREPARATION OF TEST SPECIMEN:

3.1 Number Of Test Specimens:

One test specimen of the same quality and the same nominal thickness per test unit is required. DIN 46400 - Part 1 - Section 7.2 & 7.3 is applicable for classification of test units and number of test specimens.

3.2 Sampling And Preparation Of Specimens:

3.2.1 The outermost and innermost turn of a coil or the top most and bottom most of a stack of sheets shall be considered as wrapping and are not representative of the properties of the remaining material and hence, shall not be considered for test specimen.

3.2.2 In case of coils, the test specimens shall preferably be taken from the first external turn excluding the wrapping turn and in the case of sheet, it shall be from the upper part of the stack. In special case, it can be taken from any other part also.

3.2.3 The test specimen shall extend over the entire sheet width and can be about 350 ± 2 mm long. In case of sheet width below 400 mm, the specimen shall be 500 ± 2 mm long.

3.2.4 The surface of the strip shall be free from contaminations and damages and shall be cut without deformation and as far as possible, without burrs. Any cleaning done shall not damage the insulating coating.

Revision: Refer cl.27.8.3 of
MOM of MRC (E)

Approved:
INTERPLANT STANDARDIZATION
COMMITTEE-WG (MRC (E))

Rev.No.

Amd.No.

Reaffirmed

Prepared
BHOPALIssued
CORP. R&D

Dt. of 1st issue

Dt.

Dt.

Year:

JAN 94

**4. TEST METHODS:****4.1 CURING OF THE VARNISH:**

The test to check whether the varnish is completely cured, shall be done by rubbing the insulation with a pad dipped in methyated spirit with force by hand.

The varnish shall not dissolve by this rubbing.

4.2 Varnish Layer Thickness:

4.2.1 The test method shall be as per DIN 50981 and DIN 50982 - Part 1 and Part 3 with the following :

4.2.2 Methods Of Measurement:

The varnish layer thickness of the magnetic steel sheet shall be determined by the principle of magnetic induction. Conventional measuring instruments shall be used. The instruments shall be calibrated using comparison specimens (2 - point adjustment), before measuring.

4.2.3 Calibration Of The Instrument:

The base material of the sheet to be tested shall be used as the comparison specimen, after the removal of its varnish layer by dissolution in a suitable solvent (e.g. by potassium Hydroxide - 21 weight % KOH) without any change in the surface of the base material. An unvarnished test specimen of the magnetic steel sheet can also be used for this purpose, if available. A non-ferro-magnetic foil of known thickness, approximately same as that to be measured is used as the standard for layer thickness.

4.2.4 Test Procedure:

The varnish thickness is measured at least at 10 points of the test specimen, distributed evenly on the sheet width. The arithmetic mean value of all measurements and double the standard deviation "2S" are given as the layer thickness of varnish coating.

Each side shall be measured separately at the corresponding positions and each test specimen has to fulfill the thickness requirements.

The thickness of any pre-coating shall not be accounted for.

4.3 Inter-Laminar Resistance:

The inter-laminar resistance shall be measured as per ASTM A-717 / IEC 404 (Franklin Test Method).



4.4 Surface Quality:

The surface quality of the magnetic sheets, when measured in terms of Stacking Factor as per IS - 649 / BS 601 - part 5 - Clause 3 (on a minimum of 16 samples under a pressure of $35 \pm 1\% \text{ N/cm}^2$) shall comply with the values specified in the material purchase specification.

The stacking factor shall be calculated from the following relationship :

$$\text{Stacking Factor} = \frac{m}{p \times h \times l \times w} \times 10^{11} \%$$

where

- m = Total mass of test specimen (kg)
- p = Density of material (kg/m^3)
- h = Height of stack (mm)
- l = Mean length of test specimen (mm)
- w = Mean width of test specimen (mm)

4.5 Adherence:

The insulation coating shall not peel off when cutting the sheet with a sharp cutting tool (except from the edges). It shall withstand the reverse bending test, specified in the material purchase specification, without damage to the insulation.

5. TYPE TESTS:

The following type tests are to be carried out for varnish type once only. Unless otherwise stated, the specimens are coated with a standard layer thickness of 7 Microns on each side ± 1.5 Microns. However total deviation on both sides of the varnish coating shall not be more than 2.6 mm.

5.1 Thermal Effect On Coating:

Three specimens of varnished strip shall be clamped together under a pressure of $1 \pm 1\% \text{ N/mm}^2$ and heated in a laboratory oven at a temperature of $130 \pm 3^\circ\text{C}$ for a period of one week. After cooling to room temperature, the interlaminar resistance value of the middle specimen shall not be less than the minimum values specified in the material purchase specification.

5.2 Resistance To Oil, Solvent And Ammonia:

5.2.1 Resistance To Solvent:

When tested as per DIN 53168, a cotton plug soaked with the test liquid is placed on the conventionally applied and cured varnished layer and covered with a glass shell and left for one hour.

The varnished layer is compared with an untested specimen after 5 minutes and again after one hour after the test. No visible changes shall appear on the varnished layer.

**5.2.2 Resistance To Oil:**

When tested as per DIN 46456 - Part 1 - Clause 6.3.10, a test specimen of the varnished sheet shall be stored in Transformer Oil (to IS 335) at a temperature of $105 \pm 3^{\circ}\text{C}$. There should not be any change in the colour of the oil (as compared to its original colour) and varnished layer of the specimen.

5.2.3 Resistance To Ammonia:

This test shall be carried out when specifically mentioned in the order or material purchase specification.

Test specimens shall be of 100 mm x 100 mm size cut from the varnished strip. The edges of the specimen are sealed with paraffin and are kept horizontally (with about 1 cm distance) in a closed vessel at a room temperature of $25 \pm 5^{\circ}\text{C}$. The bottom of the vessel is filled with 25% aqueous Ammonia solution so that the specimens are exposed to a water vapour ammonia atmosphere.

After storage for four weeks, the varnish coating shall not peel off when scratched by a finger nail.

6. Retests:

As per DIN 46400 - Part 1 - Section 7.6.

7. REFERRED STANDARDS:

The following is the list of the latest standards, as published by the respective issuing bodies, referred to in this specification.

1. IS:649
2. IS:335
3. B.S.601 Part 5. Cl.3.
4. ASTM A-717
5. DIN 46400 -Part 1, Sec 7.2. and Sec 7.6
6. DIN 46456 Part 1.cl 6.3.10
7. DIN 50981
8. DIN 50892-Part 1 and 3
9. DIN 53168



ANNEXURE 1

TEST CERTIFICATE FORMAT (Clause 1)

1. Name of Varnish Manufacturer :
2. Type of Varnish :
3. PROPERTIES OF THE VARNISH
 - 3.1 Type of resin :
 - 3.2 Type of filler :
 - 3.3 Type of Solvent : Wt. %
 - 3.4 Water content in case of water thinnable varnish : Wt. %
 - 3.5 Solid content : Wt. % Vol. %
 - 3.6 Resin content : Wt.% w.r.t. solids
 - 3.7 Filler content : Wt.% w.r.t. solids
 - 3.8 Density of varnish : g/ml
 - 3.9 Viscosity as per DIN 53211 : s
(4mm, 23°C)
 - 3.10 Flame point as per DIN 53213 : °C
4. PROPERTIES OF THE CURED VARNISH FILM AFTER PROCESSING, AS PER SPECIFICATION
 - 4.1 Surface weight of a 7 μ thick varnish layer (Dry weight) : g/m²
 - 4.2 Interlaminar resistance to ASTM A 717/IEC 404 (Franklin Method) : ohm-cm²
 - 4.3 Surface quality : %
 - 4.4 Thermal effect on coating : °C
 - 4.5 Influence on the punching quality of the sheet :
 - 4.6 Resistance to oil, organic solvents, water and ammonia. :
5. DATA OF THE VARNISH PROCESSOR:
 - 5.1 Name of the varnish processor :
 - 5.2 Mode of application :
 - 5.3 Drying temperature : °C
 - 5.4 The insulating varnish _____ supplied by _____ is used for our magnetic steel sheet insulation. The varnish is used without any change and as specified by the manufacturer

Date and Signature of the supplier

Note:

Any change in the composition of the varnish or individual substances shall be communicated to BHEL without delay.