

Corrigendum-I to BHEL Enquiry E4523037

This corrigendum is being issued to publish some additional drawings/ specification required for quotation against the tender.

Vendors are requested to submit their offers accordingly.

All other terms and conditions remain same.

THE INFORMATION ON THIS DOCUMENT IS THE PROPERTY OF BHARAT HEAVY ELECTRICALS LIMITED. IT MUST NOT BE USED DIRECTLY OR INDIRECTLY IN ANY WAY DETRIMENTAL TO THE INTEREST OF THE COMPANY.

FIRST ANGLE PROJECTION

ALL DIMENSIONS ARE IN mm

DRG. NO. 25219002522

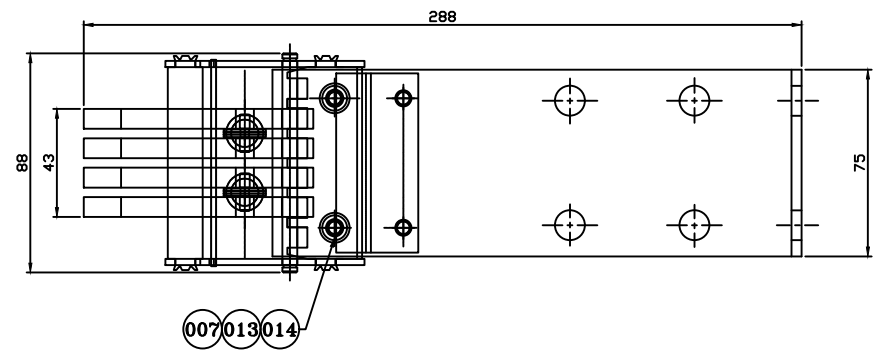
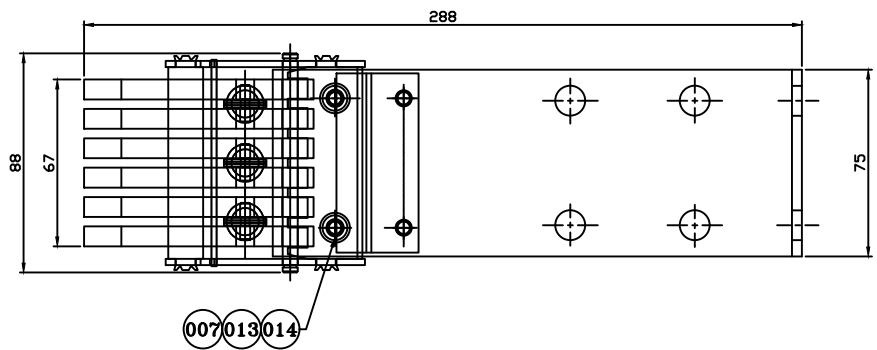
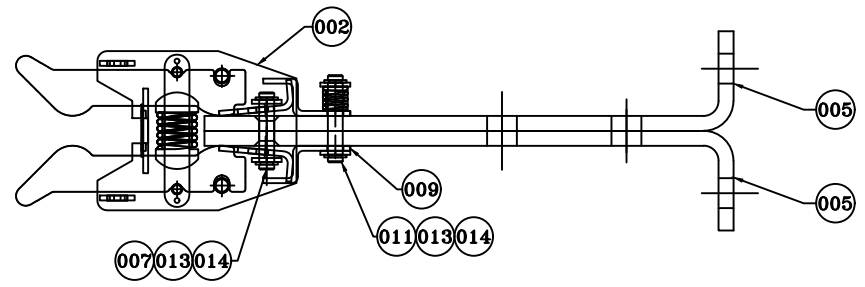
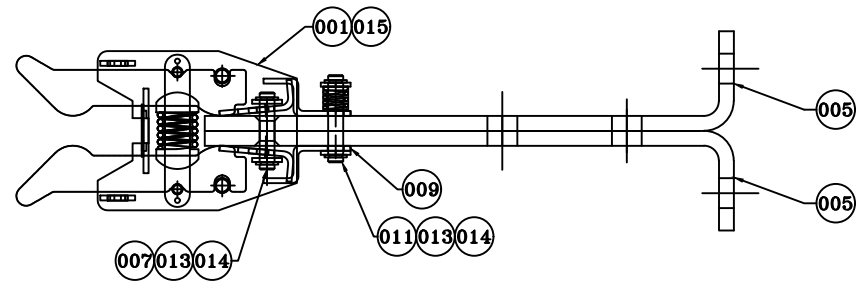

VAR. 00 & 04

(2 NOS.-6TK. x 75 WIDE CONNECTOR)
BP 9099111371

VAR. 01 (JAW TIN PLATED)

(2 NOS.-6TK. x 75 WIDE CONNECTOR)
BP 9099111355

59	64	65	75	78	79	85	27	29	58	59	60	77	29	31	34	45	55	56	57	58	65	72
VAR00	REMARKS	VAR. NO.	ITEM NO.	DESCRIPTION	STD.	DRAWING NO.	IT.NG.	MATL. CODE	UNIT	QTY.	UNIT WT.	ZONE										

ADDITIONAL INFORMATION

STATUS OF DRAWING: B

DISTRIBUTION OF PRINTS:
O/C - 1 TCX - 1
SWM - 3

उत्पाद का प्रकार वा शाहक/परियोजना का नाम
TYPE OF PRODUCT OR NAME OF CUSTOMER/PROJECT

VM-12 (BT-II)

भारत हेवी इलेक्ट्रिकल्स लिमिटेड
BOPAL
BHARAT HEAVY ELECTRICALS LTD.
BHOPAL

नाम/NAME	हस्ताक्षर/SIGN.	दिनांक/DATE	रि. ली. संख्या
S.U.S.		29.12.01	संख्या
S.S.A.		29.12.01	IND. OF VAR.
J.S.P.		29.12.01	05

विभागाध्यक्ष/अ.प्र.का. के अधीन
DEPT. SWE. UNTL. DIMS. GR. M
कोड 409 AA 0230208

उत्सृष्ट/SCALE: 1:1

भार (कि.ग्रा.)/WEIGHT (K.G.): -

उत्प्रेषण/REF. TO ASSY. DRG.: -

मदक संख्या/ITEM NO.: -

मदक संख्या/IND. OF ITEM: 015

सं. सं. संख्या/REV. NO.: 05

ड्राइंग का संख्या/DRAWING NO.: 25219002522

पृष्ठ सं. /SHT. NO. 01 / कुलों की संख्या/IND. OF SHT. 02

TOP CONTACT ASSY.

REFER SH. NO. 02 FOR BOM.

REV.	DATE	ALTERED CHECKED AT APPROVED	SKG	REV.	DATE	ALTERED CHECKED APPROVED	P. PARE	REV.	DATE	ALTERED CHECKED APPROVED	SUS	REV.	DATE	ALTERED CHECKED APPROVED	SUS	REV.	DATE	ALTERED CHECKED APPROVED	SUS	REV.	DATE	ALTERED CHECKED APPROVED	SUS	
05	26.10.21			04	10.8.10		K.S.MANI MAK	03	16.3.06		SSA RM	02	7.3.06		SSA RM	01	4.3.06		SSA RM					
			VAR 04 & ITEM 015 ADDED. (DCA 37335)				WT. OF CPR. FOR VAR. 00 TO 03 ADDED (DCA NO.29914)				VAR. DESCRIPTION MODIFIED (DCA NO.25317)				AMP.RATING REMOVED (DCA-25290)				VIEW CORRECTED (DCA-25275)					

WT. OF CPR. FOR :-

- VAR-00 - 3.088 KG.
- VAR-01 - 2.712 KG.
- VAR-02 - 4.934 KG.
- VAR-03 - 4.934 KG.
- VAR-04 - 3.088 KG.

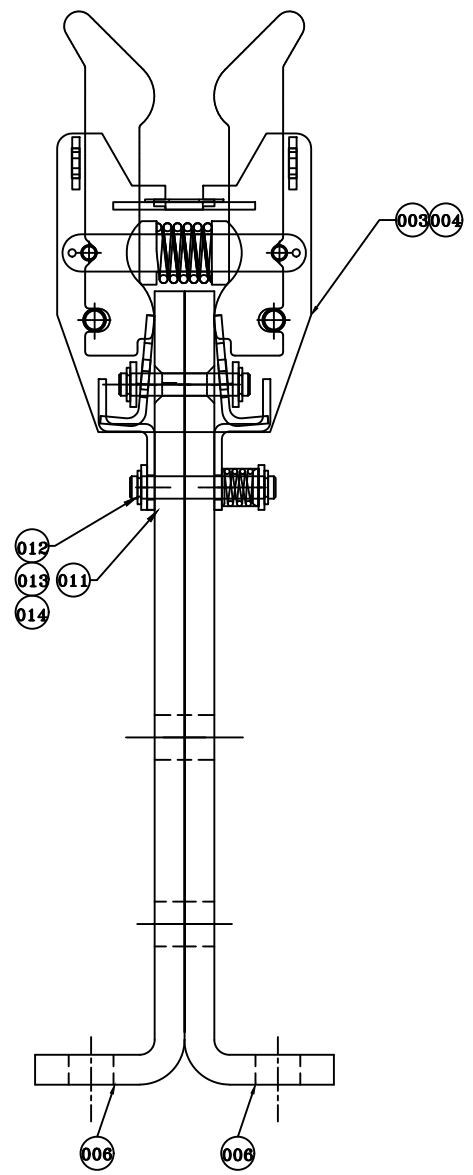
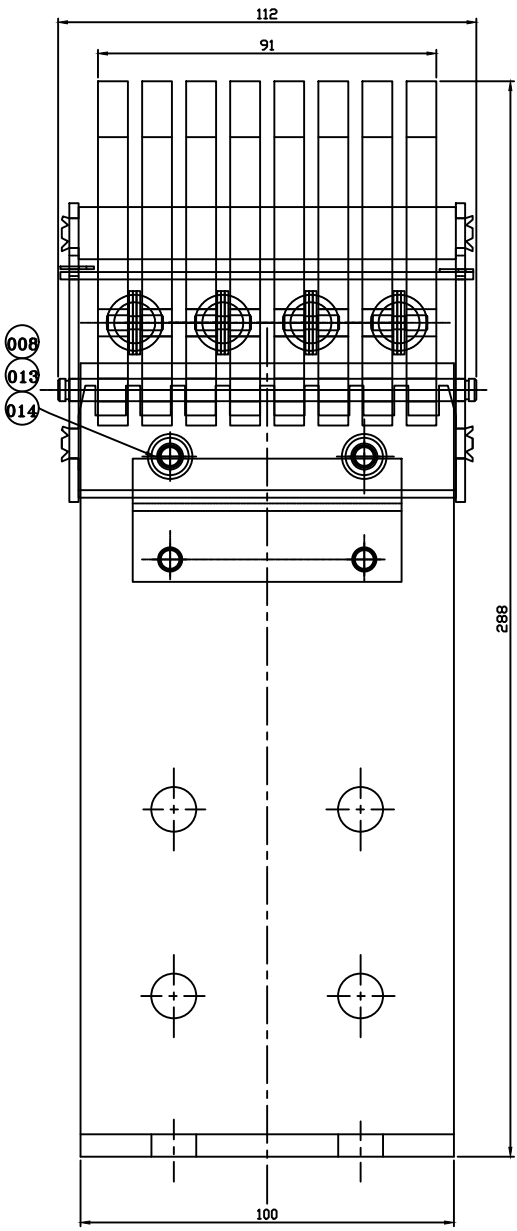

REV.	DATE	ALTERED	SUS	DESCRIPTION	DRAWING NO.	UNIT WT.	QTY.
001	-	-	-	015 PLUG IN CONTACT ASSY.	35211001721	07	-
008	008	008	008	014 CIRCLIP C5-ST			AA7167006
008	008	008	008	013 WASHER MCD 6.4-ST			AA7167006
-	002	002	-	012 GROOVE PIN	45211001727	007	-
002	002	002	002	011 GROOVE PIN	45211001727	006	-
002	002	002	002	010 SPRING	35211001730	001	-
002	002	002	002	009 CATCH	35211001734	001	-
-	002	002	-	008 GROOVE PIN	45211001727	004	-
002	-	-	002	007 GROOVE PIN	45211001727	005	-
-	002	002	-	16TK 006 TDP FIXED CONNECTION	35219005500	002	1.715 001
002	-	-	002	12TK 005 TDP FIXED CONNECTION	35219005500	001	0.980 001
-	001	-	-	004 PLUG IN CONTACT ASSY.	35211001721	01	-
-	-	001	-	003 PLUG IN CONTACT ASSY.	35211001721	02	-
-	-	-	001	002 PLUG IN CONTACT ASSY.	35211001721	03	-
-	-	-	001	001 PLUG IN CONTACT ASSY.	35211001721	04	-

VAR. 02 & 03
(2NOS.-8TK. x 100 WIDE CONNECTOR)

ADDITIONAL INFORMATION

STATUS OF DRAWING B

DISTRIBUTION OF PRINTS
O/C -1 TCX -1
SWM -3

उत्पाद का प्रकार या ग्राहक/परियोजना का नाम
TYPE OF PRODUCT OR NAME OF CUSTOMER/PROJECT

VM-12 (BT-II)

भारत हेवी इलेक्ट्रिकल्स लिमिटेड
BOPAL

गण/NAME	हस्ता/SIGN.	दिनांक/DATE	र. सं. NO.
S.U.S.		29.12.01	संख्या NO. OF
S.S.A.		29.12.01	VAR.
J.S.P.		29.12.01	05

विभाग DEPT/SWE
उत्पाद UNITDL. DIMS. GR.
कोड CODE AA 0230208

उत्पाद भार (किलोग्राम) SCALE WEIGHT (K.G.)
1:1

उत्पाद संख्या REF. TO ASSY. DRG. 25219002522

मदक नं. IND. OF ITEM 015

सं. संख्या REV. 05

ड्राइंग नं./DRAWING NO. 25219002522

पृष्ठ सं./SHT. NO. 02/पृष्ठों की संख्या/IND. OF SHT. 02

THE INFORMATION ON THIS DOCUMENT IS THE PROPERTY OF BHARAT HEAVY ELECTRICALS LIMITED. IT MUST NOT BE USED DIRECTLY OR INDIRECTLY IN ANY WAY DETRIMENTAL TO THE INTEREST OF THE COMPANY.

INVENTORY NO. 25219002522-R03-302
SIGN AND DATE REF. DRG. NO.

THE INFORMATION ON THIS DOCUMENT IS THE PROPERTY OF BHARAT HEAVY ELECTRICALS LIMITED. IT MUST NOT BE USED DIRECTLY OR INDIRECTLY IN ANY WAY DETRIMENTAL TO THE INTEREST OF THE COMPANY.



DRG NO. 3 521 10 01 721

VAR. 08	VAR. 07	VAR. 06	VAR. 05	VAR. 04	VAR. 03	VAR. 02	VAR. 01	VAR 00	REMARKS	VAR NO.	ITEM NO.	DESCRIPTION	PLS	DRAWING NO.	IT.NO. VAR	MATERIAL CODE MATL. SPCN. C	A	UNIT	UNIT WT. QTY
-	-	-	-	-	-	012	012	-			014	SPRING PULL ROD		35211001731	002				0.004
-	-	-	-	-	-	-	-	012			013	SPRING PULL ROD		35211001731	001				0.004
004	004	004	004	004	004	004	004	004			012	CIRCLIP C5-ST				AA 7167006			0.001
002	002	-	002	002	002	-	-	-			011	GROOVE PIN		45211001727	002				0.018
-	-	002	-	-	-	002	002	002			010	GROOVE PIN		45211001727	001				0.023
-	-	-	004	012	008	016	-	-			009	JAW CONTACT		35211001727	002				0.085
004	012	016	-	-	-	-	016	016			008	JAW CONTACT		35211001727	001				0.085
002	002	002	002	002	002	002	002	002			007	COTTER PIN		45211001729	001				0.001
001	001	-	001	001	001	-	-	-			006	SHUTTER		35211001724	003				0.036
-	-	-	-	-	-	001	001	-			005	SHUTTER		35211001724	002				0.052
-	-	-	-	-	-	-	-	001			004	SHUTTER		35211001724	001				0.057
001	001	-	001	001	001	-	-	-			003	JAW BODY		35211001723	02				0.276
-	-	-	-	-	-	001	001	-			002	JAW BODY		35211001723	01				0.320
-	-	-	-	-	-	-	-	001			001	JAW BODY		35211001723	00				0.330
VAR. 08	VAR. 07	VAR. 06	VAR. 05	VAR. 04	VAR. 03	VAR. 02	VAR. 01	VAR 00	REMARKS	VAR NO.	ITEM NO.	DESCRIPTION	PLS	DRAWING NO.	IT.NO. VAR	MATERIAL CODE MATL. SPCN. C	A	UNIT	UNIT WT. QTY

35211001721-R04-S07 REF.DRG.NO.

SIGN. & DATE

INVENTORY NO.

REV 06	DATE 05.01.22	ALT. CKD.	AT APPD.	REV 05	DATE 03.12.20	ALT. CKD.	AT APPD.	ADDITIONAL INFORMATION		TYPE OF PRODUCT OR NAME OF CUST/PROJ		VM-12 (BT-2)							
VAR06 ADDED (DCA NO. 37429)				VAR07 ADDED (DCA NO. 36965)				STATUS OF DRAWING		DISTRIBUTION OF PRINTS		 BHARAT HEAVY ELECTRICALS LIMITED BHPAL		DRN	NAME	SIGN	DATE	NO. OF VAR	
-FOR IT-011 QTY. CHANGED TO 002NDS. FROM 003 NDS. -FOR IT-005 QTY. NULLIFIED FOR VAR.04 -WEIGHT OF COPPER MENTIONED FOR VAR.00,01,02,03,04 IN SHT#08 (DCA NO. 29558)				VAR. 06 & SHT. 08 ADDED. BDM REARRANGED. (DCA NO. 26965)				DRG. CORRECTED. (DCA NO. 26952)		DRN SUS CKD SSA APPD ANITA		DEPT SWE	UN. TOL.DIMGR.	SCALE	WEIGHT (KG.)	REF TO ASSY	ITEM MD.	NO. OF ITEMS	
										TITLE		D.BHATT		22.08.07	09				
										409		 PLUG IN CONTACT ASSY.		DRG NO		3 521 10 01721		REV.	
												07		NO. OF SHT.		08			

FIRST ANGLE PROJECTION

ALL DIMENSIONS ARE IN mm.

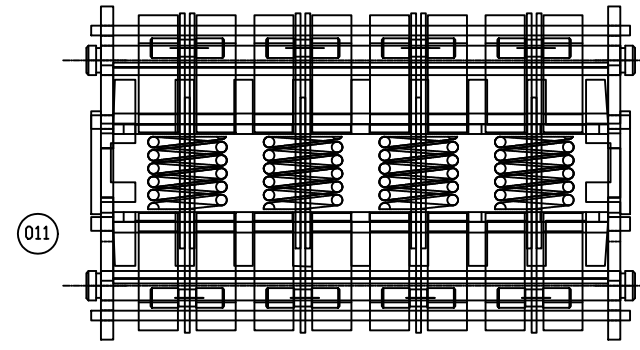
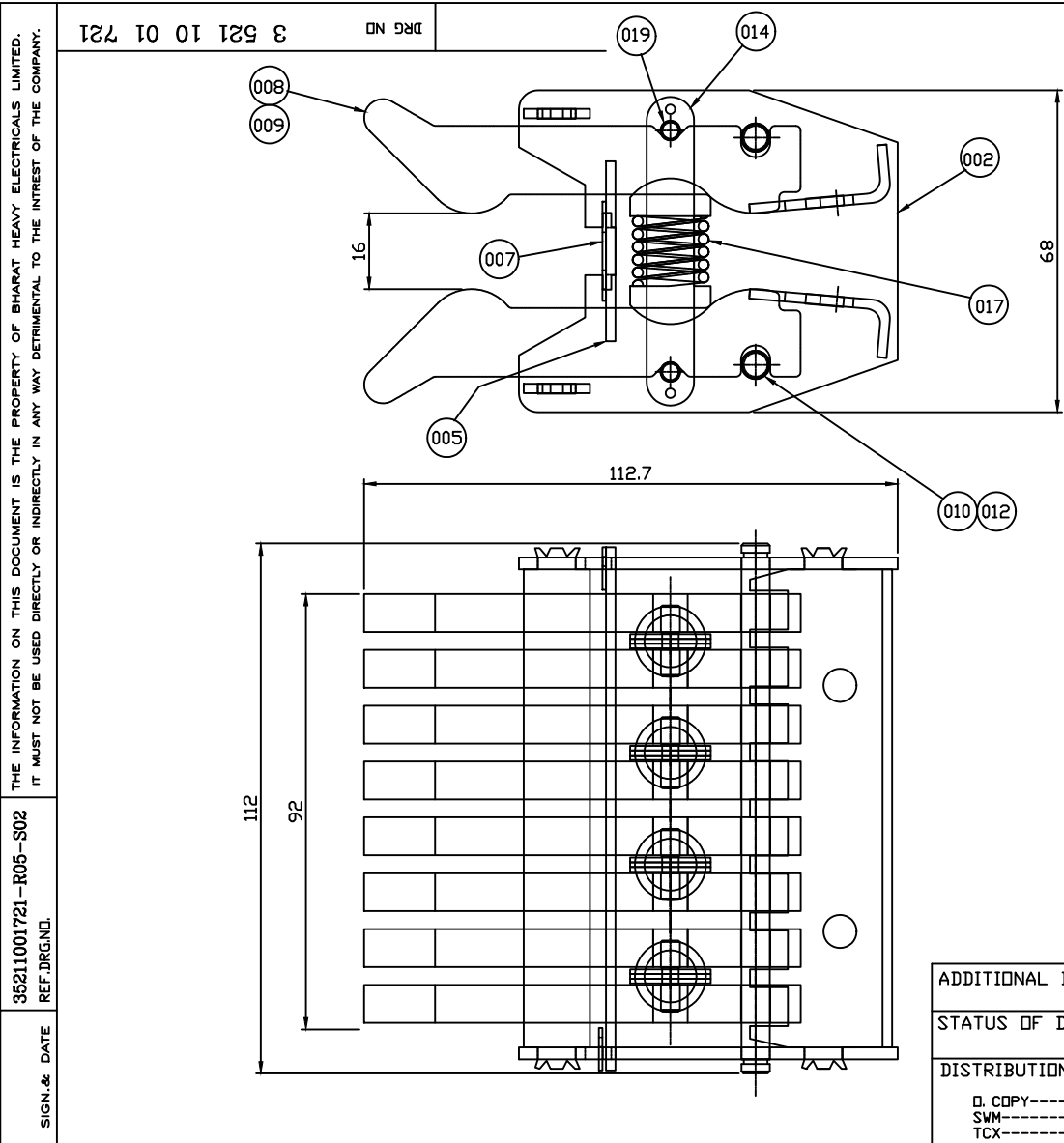



VAR-01 & 02
 (VAR.01-16 TK. x 100 WIDE CONNECTOR -2500 Amps.)
 (VAR.02-16 TK. x 100 WIDE CONNECTOR -2000 Amps.)

35211001721-R05-S02
 REF.DRG.ND.
 SIGN. & DATE
 INVENTORY NO.

3 521 10 01 721
 DRG NO

REV	DATE	ALT.	AT	REV	DATE	ALT.	AT	REV	DATE	ALT.	P.PARE
06	05.01.22	CKD.	AT	05	03.12.20	CKD.	AT	04	11.08.10	CKD.	MANI
		APPD.	AD			APPD.	AD			APPD.	DIVYA
	VAR08 ADDED				-VAR07 ADDED.				-FDR IT-011 QTY. CHANGED TO 002NDS. FROM 003 NDS. -FDR IT-005 QTY. NULLIFIED FOR VAR.04 -WEIGHT OF COPPER MENTIONED FOR VAR.00,01,02,03,04 IN SHT#08		
	(DCA NO. 37429)				(DCA NO. 36965)				(DCA NO. 29558)		

ADDITIONAL INFORMATION				TYPE OF PRODUCT OR NAME OF CUST/PROJ													
STATUS OF DRAWING				VM-12 (BT-2)													
DISTRIBUTION OF PRINTS				 BHARAT HEAVY ELECTRICALS LIMITED BHOPAL				DRN SUS 22.08.07		NAME D.BHATT 22.08.07		SIGN 22.08.07		DATE 22.08.07		NO. OF VAR 09	
□ COPY-----1 SWM-----3 TCX-----1				DEPT SWE CODE 409		UN. TOL.DIM.GR.		 SCALE 1:1		WEIGHT (KG.)		REF TO ASSY		ITEM MD.		NO.OF ITEMS 019	
REV 03 22.08.07 ALT. SUS CKD. SSA APPD. DIVYA				VAR. 06 & SHT. 08 ADDED. BDM REARRANGED.				TITLE PLUG IN CONTACT ASSY.				DRG NO 3 521 10 01721		REV. 06			
				SHT.ND. 02		NO. OF SHT. 08											

FIRST ANGLE PROJECTION

ALL DIMENSIONS ARE IN mm.

THE INFORMATION ON THIS DOCUMENT IS THE PROPERTY OF BHARAT HEAVY ELECTRICALS LIMITED. IT MUST NOT BE USED DIRECTLY OR INDIRECTLY IN ANY WAY DETRIMENTAL TO THE INTEREST OF THE COMPANY.

35211001721-R05-S03 REF.DRG.ND.

SIGN. & DATE

INVENTORY NO.

DRG NO 3 521 10 01 721

IT. 009 FOR VAR04
IT. 008 FOR VAR07

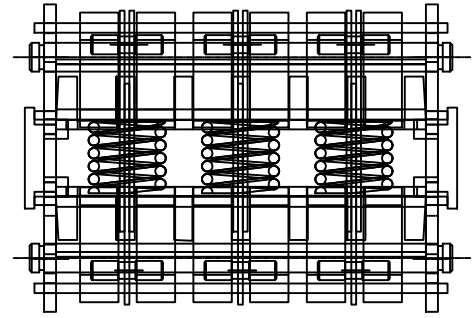
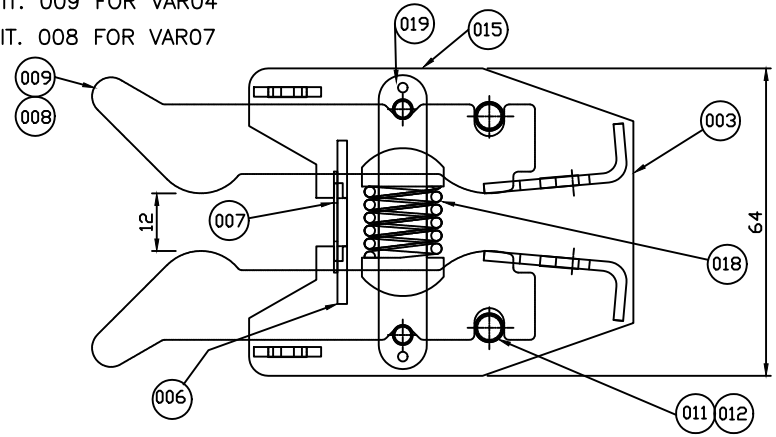

VAR-04/VAR07
(12 TK x 75 WIDE CONNECTOR -1250 Amps.)

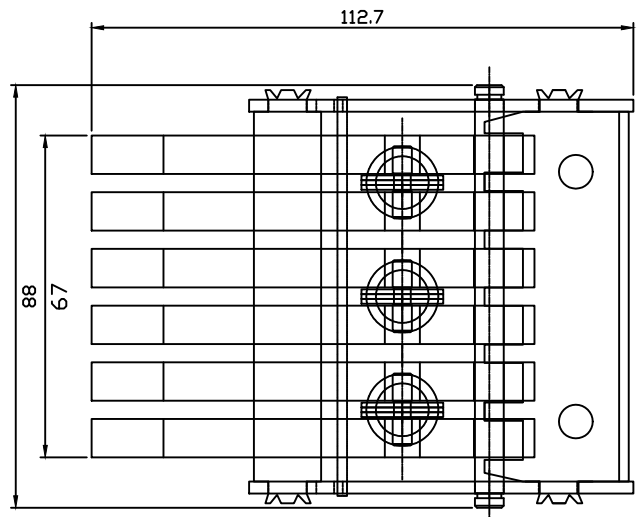

ADDITIONAL INFORMATION				TYPE OF PRODUCT OR NAME OF CUST/PROJ																		
STATUS OF DRAWING				VM-12 (BT-2)																		
DISTRIBUTION OF PRINTS					BHARAT HEAVY ELECTRICALS LIMITED BHDPAL	DRN	NAME	SIGN	DATE	NO. OF VAR												
□. COPY-----1	SWM-----3	TCX-----1	CKD			SSA		22.08.07	09													
			APPD			D.BHATT		22.08.07														
REV 06	DATE 05.01.22	ALT. CKD. APPD.	AT AD	REV 05	DATE 03.12.20	ALT. CKD. APPD.	AT AD	REV 04	DATE 11.08.10	ALT. CKD. APPD.	P.PARE MANI DIVYA	DEPT SWE	UN. TOL.DIMGR.		SCALE 1:1	WEIGHT (KG.)	REF TO ASSY	ITEM MD.	NO. OF ITEMS			
	VAR08 ADDED (DCA NO. 37429)				VAR07 ADDED FROM 003 NDS. (DCA NO. 36965)						-FOR IT-011 QTY. CHANGED TO 002NDS. FROM 003 NDS. -FOR IT-005 QTY. NULLIFIED FOR VAR.04 -WEIGHT OF COPPER MENTIONED FOR VAR.00,01,02,03,04 IN SHT#08 (DCA NO. 29558)	CODE 409									REV. 06	
											VAR. 06 & SHT. 08 ADDED. BDM REARRANGED. (DCA NO. 26965)	TITLE				PLUG IN CONTACT ASSY.			DRG NO	3 521 10 01721		REV.
																	SHT.NO.	03	NO. OF SHT.	08		

FIRST ANGLE PROJECTION

ALL DIMENSIONS ARE IN mm.

THE INFORMATION ON THIS DOCUMENT IS THE PROPERTY OF BHARAT HEAVY ELECTRICALS LIMITED. IT MUST NOT BE USED DIRECTLY OR INDIRECTLY IN ANY WAY DETRIMENTAL TO THE INTEREST OF THE COMPANY.

35211001721-R05-S04
REF.DRG.NO.



SIGN. & DATE

INVENTORY NO.

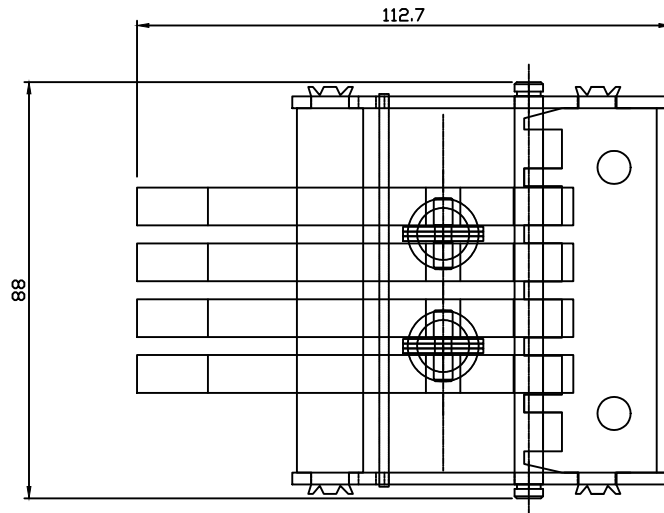
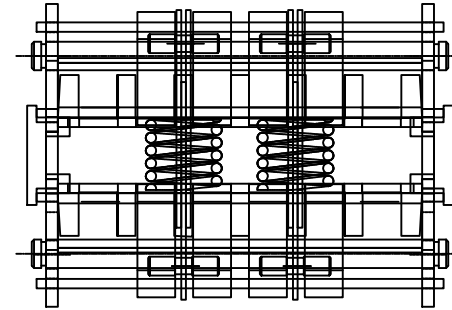
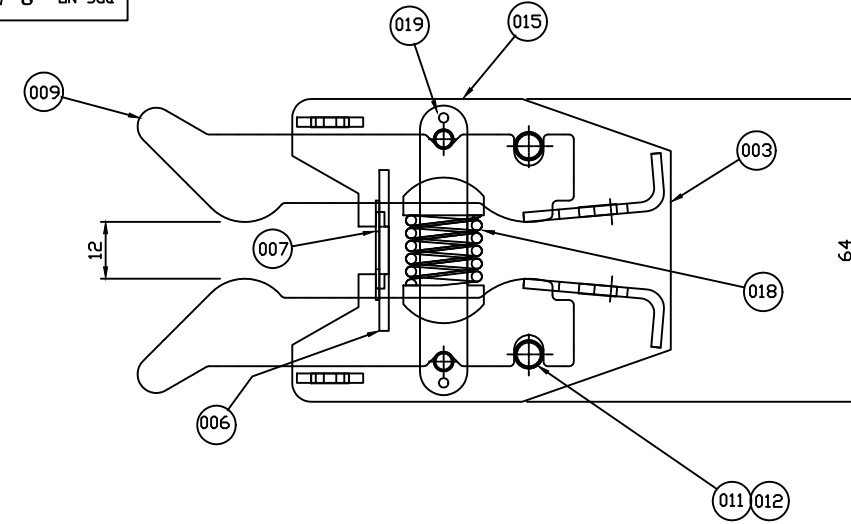
DRG NO 3 521 10 01 721



VAR-03
(12 TK. x 75 WIDE CONNECTOR - 630 Amps.)

ADDITIONAL INFORMATION				TYPE OF PRODUCT OR NAME OF CUST/PROJ VM-12 (BT-2)													
STATUS OF DRAWING				DISTRIBUTION OF PRINTS													
D. COPY-----1 SWM-----3 TCX-----1				 BHARAT HEAVY ELECTRICALS LIMITED BHOPAL				DRN SUS 22.08.07		SIGN SSA 22.08.07		DATE 22.08.07		NO. OF VAR 09			
REV 06 05.01.22 ALT. CKD. AT APPD. AD				REV 05 03.12.20 ALT. CKD. AT APPD. AD				REV 04 11.08.10 ALT. CKD. AT APPD. DIVYA				REV 03 22.08.07 ALT. CKD. AT APPD. DIVYA					
VAR08 ADDED (DCA NO. 37429)				- VAR07 ADDED. (DCA NO. 36965)				-FOR IT-011 QTY. CHANGED TO 002NDS. FROM 003 NDS. -FOR IT-005 QTY. NULLIFIED FOR VAR.04 -WEIGHT OF COPPER MENTIONED FOR VAR.00,01,02,03,04 IN SHT#08 (DCA NO. 29558)				VAR. 06 & SHT. 08 ADDED. BDM REARRANGED. (DCA NO. 26965)					
DEPT SWE				UN. TOL.DIM.GR.				 SCALE 1:1		WEIGHT (KG.)		REF TO ASSY		ITEM NO.		NO. OF ITEMS	
CODE 409				TITLE PLUG IN CONTACT ASSY.				DRG NO 3 521 10 01721				SHT.NO. 04		NO. OF SHT. 08		REV. 06	

FIRST ANGLE PROJECTION

ALL DIMENSIONS ARE IN mm.

THE INFORMATION ON THIS DOCUMENT IS THE PROPERTY OF BHARAT HEAVY ELECTRICALS LIMITED. IT MUST NOT BE USED DIRECTLY OR INDIRECTLY IN ANY WAY DETRIMENTAL TO THE INTEREST OF THE COMPANY.

35211001721-R05-S05 REF.DRG.ND.



SIGN & DATE

INVENTORY NO.

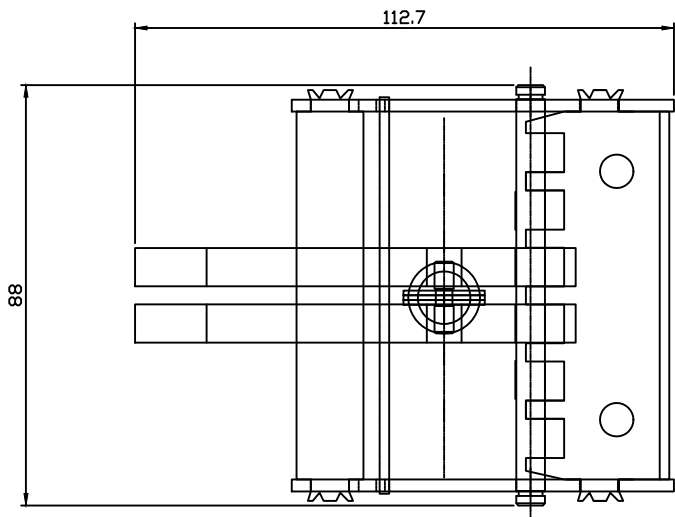
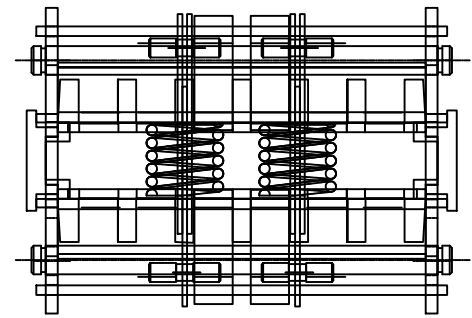
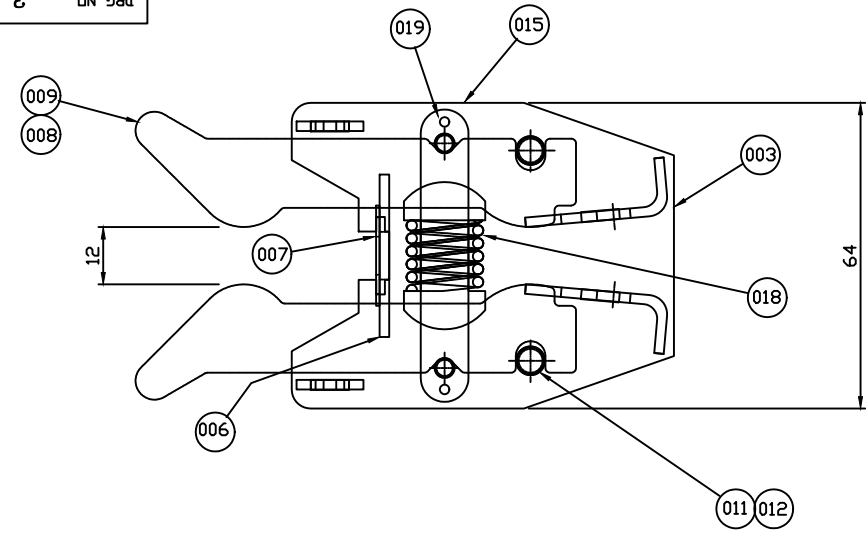
DRG NO 3 521 10 01 721



VAR-05 & 08
(12 TK. x 75 WIDE CONNECTOR - 400 Amps.)

ADDITIONAL INFORMATION				TYPE OF PRODUCT OR NAME OF CUST/PROJ																				
STATUS OF DRAWING				VM-12 (BT-2)																				
DISTRIBUTION OF PRINTS				 BHARAT HEAVY ELECTRICALS LIMITED BHOPAL	DRN	NAME	SIGN	DATE	NO. OF VAR															
D. COPY-----1 SWM-----3 TCX-----1					CKD	SUS		22.08.07																
					APPD	D.BHATT		22.08.07																
REV 06	DATE 05.01.22	ALT. CKD. APPD.	AT AD	REV 05	DATE 03.12.20	ALT. CKD. APPD.	AT AD	REV 04	DATE 11.08.10	ALT. CKD. APPD.	P.PARE MANI DIVYA	REV 03	DATE 22.08.07	ALT. CKD. APPD.	SUS SSA DIVYA	DEPT SWE	UN. TOL.DIM.GR.		SCALE 1:1	WEIGHT (KG.)	REF TO ASSY	ITEM NO.	NO. OF ITEMS	
	VAR08 ADDED				VAR07 ADDED.						-FOR IT-01 QTY. CHANGED TO 002NDS. FROM 003 NDS. -FOR IT-005 QTY. NULLIFIED FOR VAR.04 -WEIGHT OF COPPER MENTIONED FOR VAR.00,01,02,03,04 IN SHT#08				VAR. 06 & SHT. 08 ADDED. BDM REARRANGED.	CODE 409						DRG NO	REV.	
	(DCA NO. 37429)				(DCA NO. 36965)						(DCA NO. 29558)					TITLE					3 521 10 01721	06		
																					SHT.NO. 05	NO. OF SHT. 08		

FIRST ANGLE PROJECTION

ALL DIMENSIONS ARE IN mm.

THE INFORMATION ON THIS DOCUMENT IS THE PROPERTY OF BHARAT HEAVY ELECTRICALS LIMITED. IT MUST NOT BE USED DIRECTLY OR INDIRECTLY IN ANY WAY DETRIMENTAL TO THE INTEREST OF THE COMPANY.

35211001721-R05-S06
REF.DRG.ND.

SIGN. & DATE

INVENTORY NO.

DRG NO 3 521 10 01 721

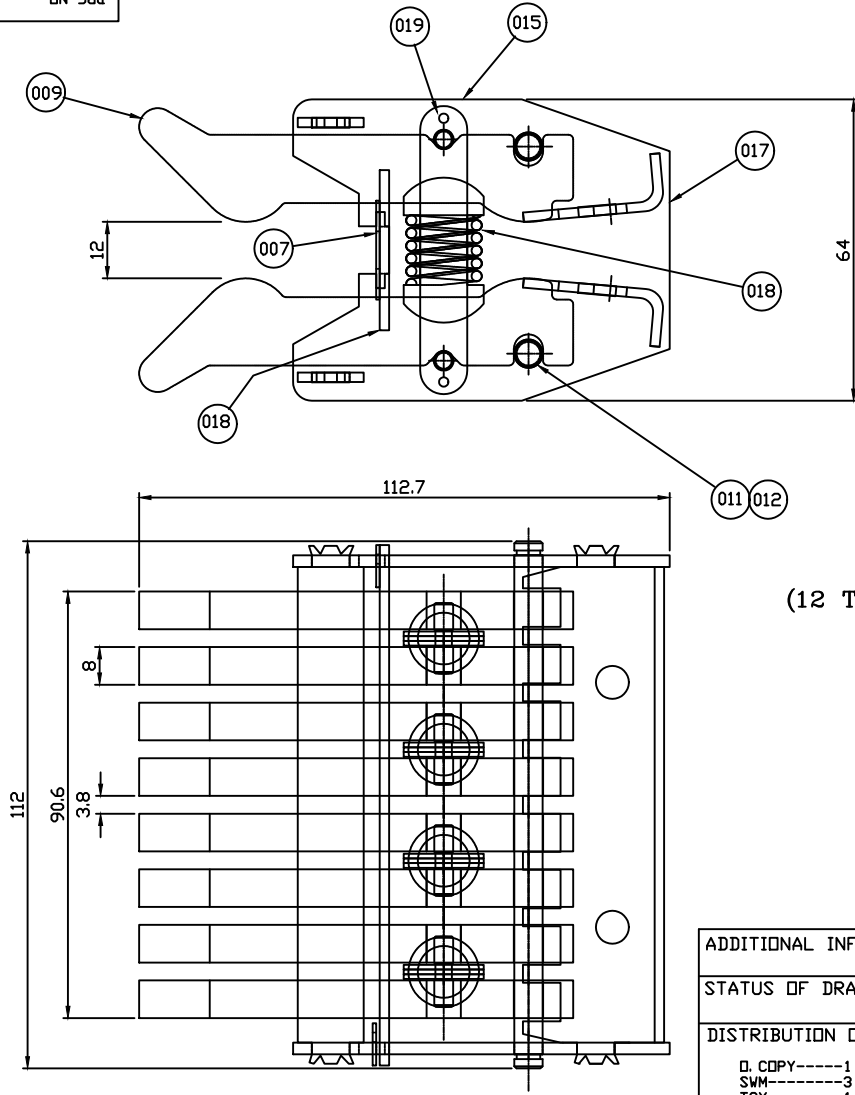

VAR-06
(12 TK x 100 WIDE CONNECTOR -2500 Amps.)

ADDITIONAL INFORMATION				TYPE OF PRODUCT OR NAME OF CUST/PROJ VM-12 (BT-2)																			
STATUS OF DRAWING				DISTRIBUTION OF PRINTS						 BHARAT HEAVY ELECTRICALS LIMITED BHOPAL				DRN	NAME	SIGN	DATE	NO. OF VAR					
D. COPY-----1				SWM-----3						TCX-----1				APPD	SUS		22.08.07	09					
REV 06 05.01.22				REV 05 03.12.20				REV 04 11.08.10				REV 03 22.08.07				DEPT	UN. TOL.DIMGR.	SCALE	WEIGHT (KG.)	REF TO ASSY	ITEM NO.	NO. OF ITEMS	
ALT. CKD. AT				ALT. CKD. AT				ALT. CKD. AT				ALT. CKD. AT				SWE		1:1					
APPD. AD				APPD. AD				APPD. DIVYA				APPD. DIVYA				CODE							
VAR08 ADDED				-VAR07 ADDED.				-FOR IT-011 QTY. CHANGED TO 002NDS. FROM 003 NDS.				VAR. 06 & SHT. 08 ADDED. BOM REARRANGED.				TITLE				DRG NO			
(DCA NO. 37429)				(DCA NO. 36965)				(DCA NO. 29558)				(DCA NO. 26965)				PLUG IN CONTACT ASSY.				3 521 10 01721			
																SHT.NO. 06				NO. OF SHT. 08			

THE INFORMATION ON THIS DOCUMENT IS THE PROPERTY OF BHARAT HEAVY ELECTRICALS LIMITED. IT MUST NOT BE USED DIRECTLY OR INDIRECTLY IN ANY WAY DETRIMENTAL TO THE INTEREST OF THE COMPANY.

DRG NO 3 521 10 01 121

NOTES :-

- 1-JAW SHALL MOVE IN THE GUIDES SMOOTHLY.
- 2-CONTACTS ARE SHOWN AS PLUG IN CONDITION.

VAR	DESCRIPTION	NO. OF JAWS	GES NO.	WEIGHT OF CU.(kg)	PLATING TYPE
00	FDR 100X20TK CONNECTOR	16	409510129	1.504	SILVER PLATING
01	FDR 100X16TK CONNECTOR	16	409510130	1.504	SILVER PLATING
02	FDR 100X16TK CONNECTOR	16	409510131	1.504	TIN PLATING
03	FDR 75X12TK CONNECTOR	08	409510132	0.752	TIN PLATING
04	FDR 75X12TK CONNECTOR	12	409510133	1.128	TIN PLATING
05	FDR 75X12TK CONNECTOR	04	409301085	---	TIN PLATING
06	FDR 100X12TK CONNECTOR	04	409301084	---	SILVER PLATING
07	FDR 75X12TK CONNECTOR	12	409301086	1.504	SILVER PLATING
08	FDR 75X12TK CONNECTOR	04	-----	0.376	SILVER PLATING

VAR.08	VAR.07	VAR. 06	VAR. 05	VAR. 04	VAR. 03	VAR. 02	VAR. 01	VAR 00	REMARKS	VAR NO.	ITEM NO.	DESCRIPTION	QTY	DRAWING NO.	IT.NO.	MATERIAL CODE	A	UNIT	UNIT WT.
											019	PIN		45211001728	001				0.002
											018	SHUTTER		35211001724	004				0.002
											017	JAW BODY		35211001723	03				0.002
											016	SPRING		35211001729	001				0.002
											015	SPRING PULL ROD		35211001731	003				0.004
																			0.001
																			0.001

35211001721-R05-S08 REF.DRG.NO.

REV 06	DATE 05.01.22	ALT. CKD.	AT
		APPD.	AD

-VAR08 ADDED
(DCA NO. 37429)

ADDITIONAL INFORMATION

STATUS OF DRAWING

DISTRIBUTION OF PRINTS
 कार्यालय प्रति ----- 1
 दस डब्ल्यू. दम. - 3
 टी. सी. दवेस. ---- 1

TYPE OF PRODUCT OR NAME OF CUST/PROJ **VM-12 (BT-2)**

 BHARAT HEAVY ELECTRICALS LIMITED BHOPAL	DRN	NAME	SIGN	DATE	NO. OF VAR
	CKD	SSA		22.08.07	09
	APPD	D.BHATT		22.08.07	

REV 05	DATE 03.12.20	ALT. CKD.	AT
		APPD.	AD

-VAR07 ADDED
(DCA NO. 36965)

REV 04	DATE 11.08.10	ALT. CKD.	P.PARE
		APPD.	MANI
			DIVYA

-FOR IT-01 QTY. CHANGED TO 002NDS. FROM 003 NDS.
 -FOR IT-005 QTY. NULLIFIED FOR VAR.04
 -WEIGHT OF COPPER MENTIONED FOR VAR.00,01,02,03,04 IN SHT#08
 (DCA NO. 29558)

REV 03	DATE 22.08.07	DRN	SUS
		CKD	SSA
		APPD	DIVYA

VAR. 06 & SHT. 08 ADDED.
 BDM REARRANGED.
 (DCA NO. 26965)

DEPT SWE	UN. TOL.DIMGR.		SCALE 1:1	WEIGHT (KG.)	REF TO ASSY	ITEM MD.	NO. OF ITEMS
CODE 409					DRG NO		REV.
TITLE PLUG IN CONTACT ASSY.				3 521 10 01721			06
SHT.NO. 08		NO. OF SHT. 08					

DRG NO 3 521 10 01 723

THE INFORMATION ON THIS DOCUMENT IS THE PROPERTY OF BHARAT HEAVY ELECTRICALS LIMITED. IT MUST NOT BE USED DIRECTLY OR INDIRECTLY IN ANY WAY DETRIMENTAL TO THE INTEREST OF THE COMPANY.

35211001723-R02-S01
REF.DRG.NO.

SIGN. & DATE

INVENTORY NO.

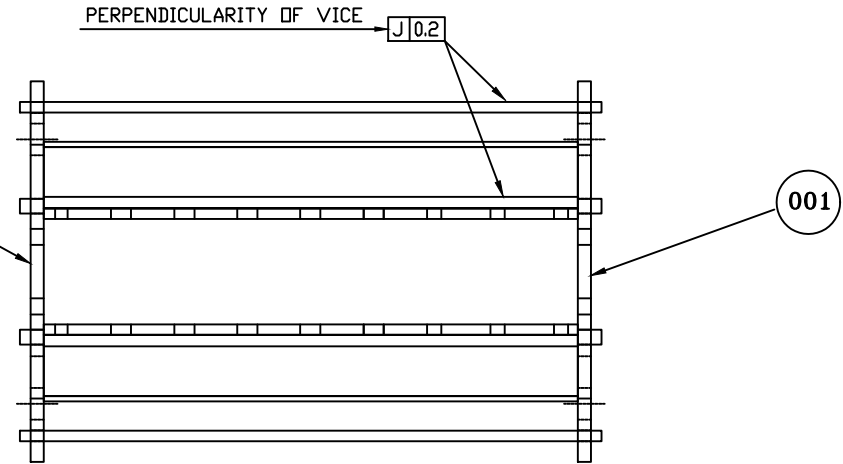
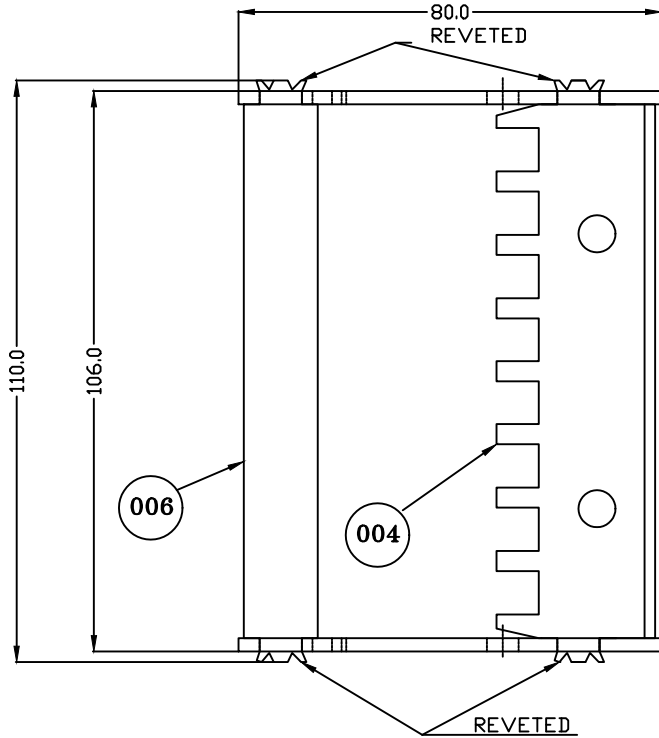
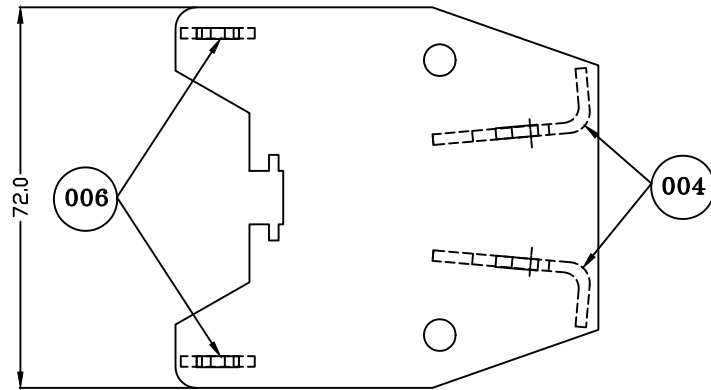

VAR-00
(SUTABLE FOR 20 TK.x100 WIDE CONNECTOR)

REFER SH. NO. 05 FOR BOM

ADDITIONAL INFORMATION				TYPE OF PRODUCT OR NAME OF CUST/PROJ										VM-12 (BT-II)								
STATUS OF DRAWING				 BHARAT HEAVY ELECTRICALS LIMITED BHOPAL										DRN	NAME		SIGN	DATE		NO. OF VAR		
DISTRIBUTION OF PRINTS														CKD	SSA		22.08.07	04				
D. COPY-----1 SWM-----3 TCX-----1				APPD	D.BHATT		22.08.07	04														
REV 02		DATE 22.08.07		ALT. SUS		CKD. SSA		APPD. DIVYA		DEPT SWE		UN. TOL.DIM.GR.		SCALE 1:1		WEIGHT (KG.)		REF TO ASSY		ITEM NO. 001		NO. OF ITEMS
REV 01		DATE 17.08.07		ALT. SUS		CKD. SSA		APPD. ANITA		CODE 409		TITLE		35211001721		003		35211001721		007		
VAR. 03 & SHT. 05 ADDED.				DRG. CORRECTED. & REDRAWN.				JAW BODY				DRG NO 3 521 10 01723				REV. 02						
(DCA NO. 26964)				(DCA NO. 26951)								SHT.NO. 01		NO. OF SHT. 05								

35211001723-R02-S02
REF.DRG.NO.

THE INFORMATION ON THIS DOCUMENT IS THE PROPERTY OF BHARAT HEAVY ELECTRICALS LIMITED.
IT MUST NOT BE USED DIRECTLY OR INDIRECTLY IN ANY WAY DETRIMENTAL TO THE INTEREST OF THE COMPANY.

SIGN. & DATE

INVENTORY NO.

DRG NO 3 521 10 01 723

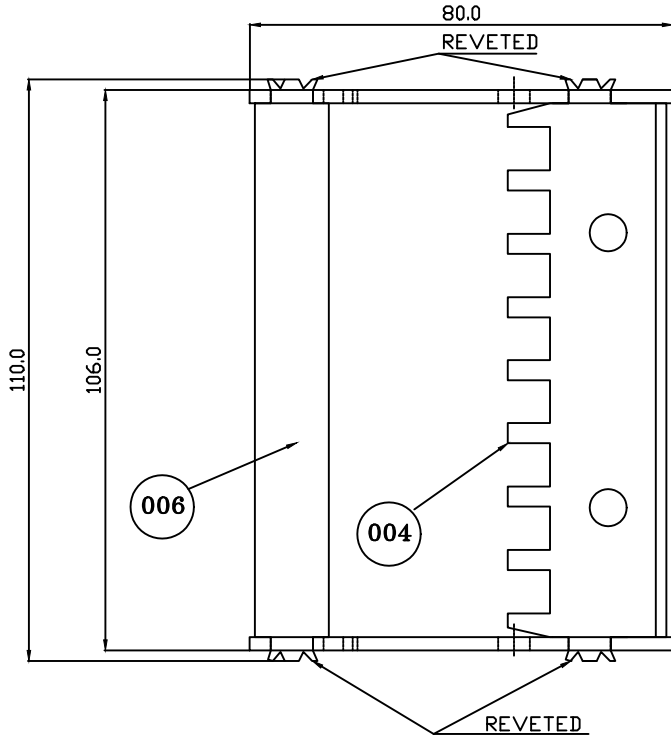
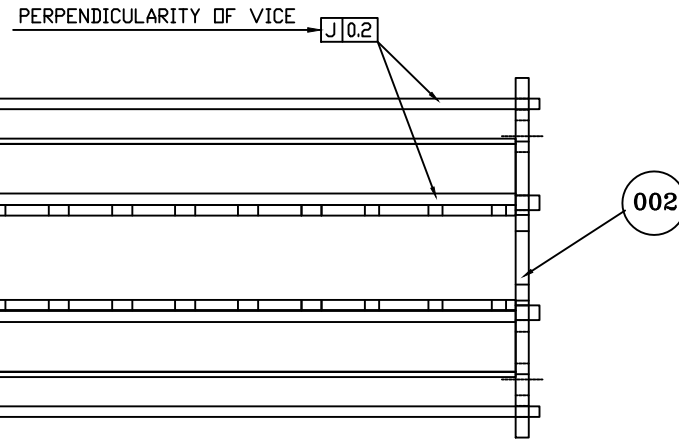
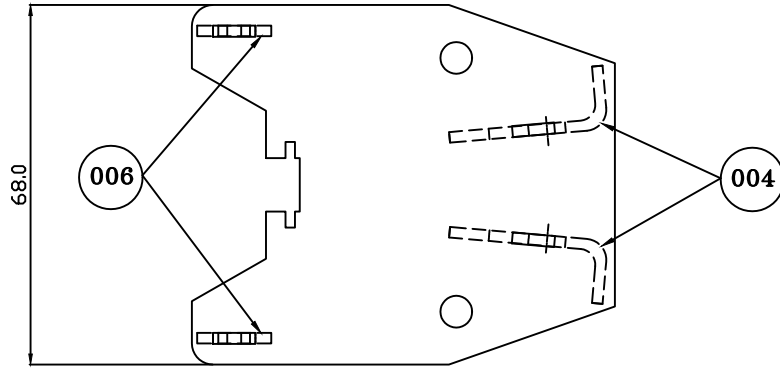

VAR-01
(SUTABLE FOR 16 TK.x100 WIDE CONNECTOR)

REFER SH. NO. 05 FOR BOM

ADDITIONAL INFORMATION				TYPE OF PRODUCT OR NAME OF CUST/PROJ				VM-12 (BT-II)					
STATUS OF DRAWING				DISTRIBUTION OF PRINTS				BHARAT HEAVY ELECTRICALS LIMITED BHPAL					
D. COPY-----1				UN. TOL.DIM.GR.				DRN		NAME		SIGN	
SWM-----3				DEPT SWE				CKD		SUS		DATE	
TCX-----1				CODE 409				APPD		SSA		22.08.07	
				TITLE				D.BHATT		D.BHATT		22.08.07	
				JAW BODY				REF TO ASSY		ITEM NO.		NO.OF VAR	
REV 02				REV 01				35211001721		001T		04	
DATE 22.08.07				DATE 17.08.07				35211001721		003		007	
ALT. SUS				ALT. SUS				DRG NO		NO. OF		REV.	
CKD. SSA				CKD. SSA				3 521 10 01723		SHT.ND.		02	
APPD. DIVYA				APPD. ANITA				02		NO. OF SHT.		05	
VAR. 03 & SHT. 05 ADDED.				DRG. CORRECTED. & REDRAWN.									
(DCA NO. 26964)				(DCA NO. 26951)									

THE INFORMATION ON THIS DOCUMENT IS THE PROPERTY OF BHARAT HEAVY ELECTRICALS LIMITED. IT MUST NOT BE USED DIRECTLY OR INDIRECTLY IN ANY WAY DETRIMENTAL TO THE INTEREST OF THE COMPANY.

35211001723-R02-S03
REF.DRG.NO.

SIGN. & DATE

INVENTORY NO.

DRG NO 3 521 10 01 723

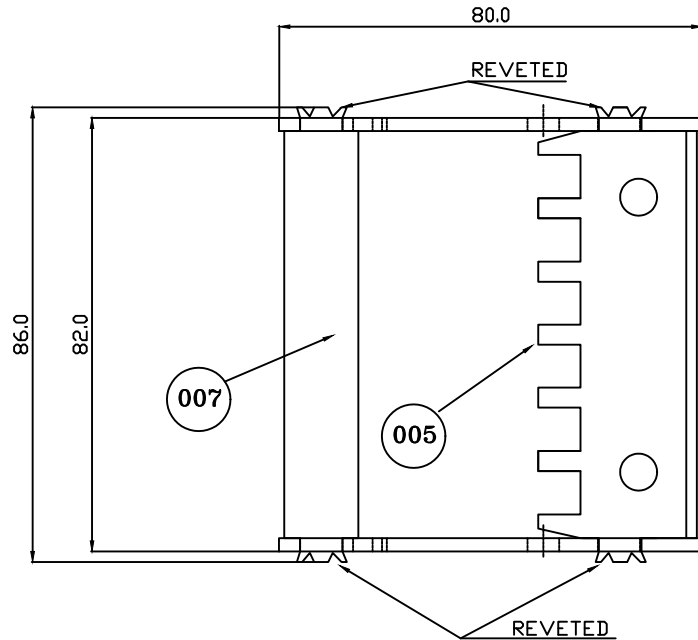
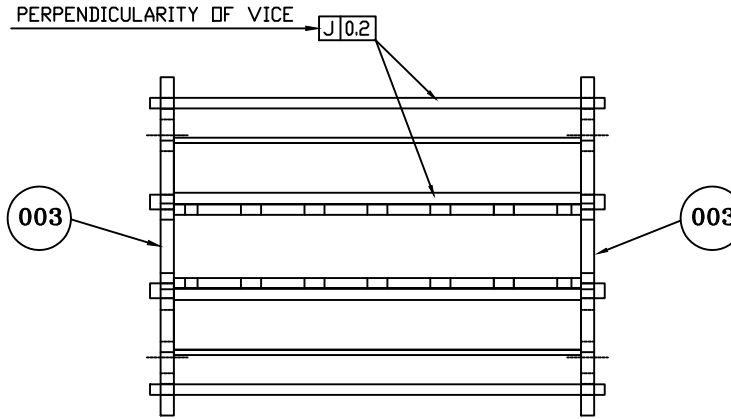
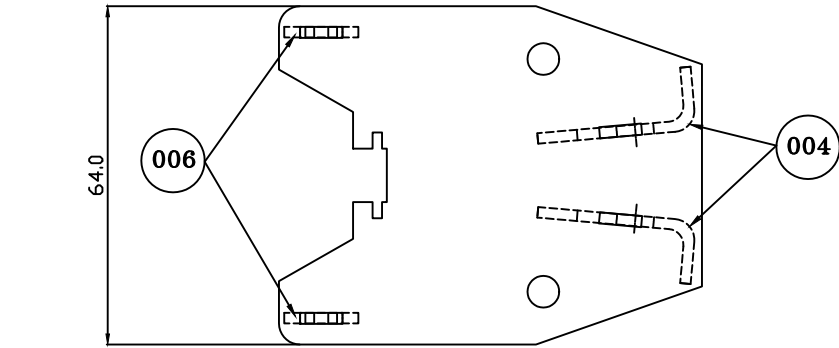

VAR-02
(SUTABLE FOR 12TK.x75 WIDE CONNECTOR)

REFER SH. NO. 05 FOR BOM

ADDITIONAL INFORMATION				TYPE OF PRODUCT OR NAME OF CUST/PROJ				VM-12 (BT-II)				
STATUS OF DRAWING				 BHARAT HEAVY ELECTRICALS LIMITED BHPAL				DRN	NAME	SIGN	DATE	NO. OF VAR
DISTRIBUTION OF PRINTS								CKD	SSA		22.08.07	04
D. COPY-----1 SWM-----3 TCX-----1								APPD	D.BHATT		22.08.07	
DEPT	UN. TOL.	DIM.	GR.	SCALE	WEIGHT (KG.)	REF TO ASSY	ITEM NO.	NO. OF ITEMS				
SWE				1:1		35211001721	001T	007				
CODE	TITLE			DRG NO			REV.					
409	JAW BODY			3 521 10 01723			02					
						SHT.NO.	03	NO. OF SHT.	05			

REV	DATE	ALT.	SUS
02	22.08.07	CKD.	SSA
		APPD.	DIVYA
VAR. 03 & SHT. 05 ADDED.			
(DCA NO. 26964)			

REV	DATE	ALT.	SUS
01	17.08.07	CKD.	SSA
		APPD.	ANITA
DRG. CORRECTED. & REDRAWN.			
(DCA NO. 26951)			

THE INFORMATION ON THIS DOCUMENT IS THE PROPERTY OF BHARAT HEAVY ELECTRICALS LIMITED. IT MUST NOT BE USED DIRECTLY OR INDIRECTLY IN ANY WAY DETRIMENTAL TO THE INTEREST OF THE COMPANY.

35211001723-R02-S04
REF.DRG.NO.

SIGN. & DATE

INVENTORY NO.

DRG NO 3 521 10 01 723

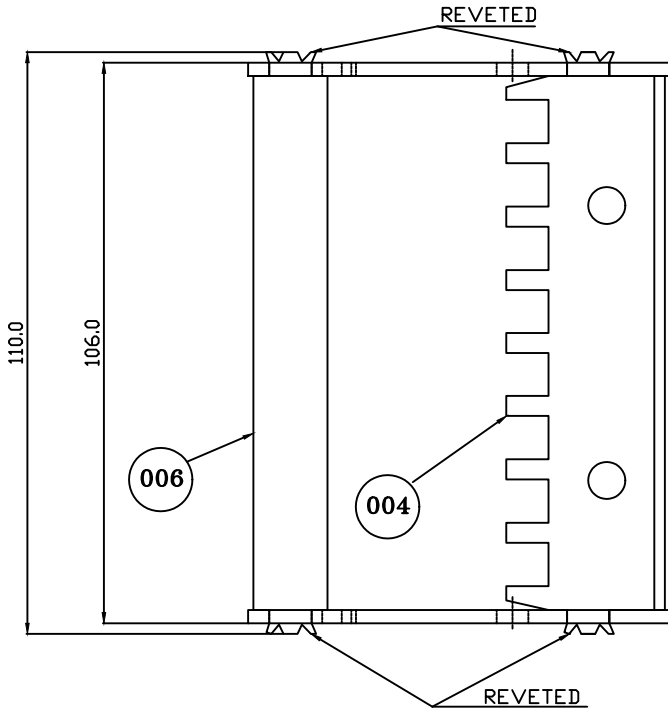
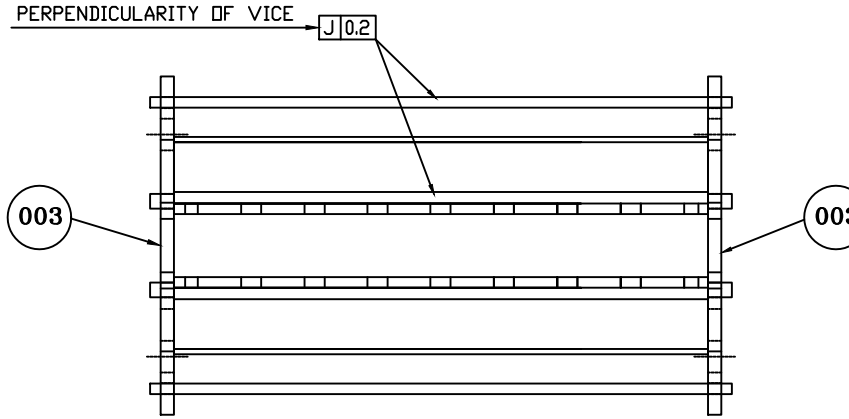
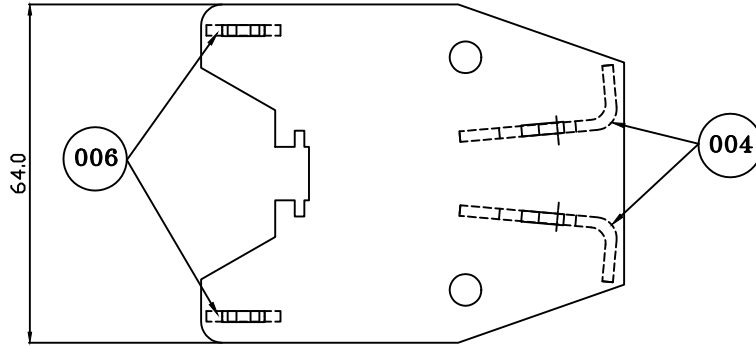

VAR-03
(SUTABLE FOR 12 TK.x100 WIDE CONNECTOR)

REFER SH. NO. 05 FOR BOM

ADDITIONAL INFORMATION				TYPE OF PRODUCT OR NAME OF CUST/PROJ				VM-12 (BT-II)									
STATUS OF DRAWING				 BHARAT HEAVY ELECTRICALS LIMITED BHPAL				DRN	NAME	SIGN	DATE	NO. OF VAR					
DISTRIBUTION OF PRINTS								CKD	SSA		22.08.07	04					
D. COPY-----1 SWM-----3 TCX-----1								APPD	D.BHATT		22.08.07						
REV	DATE	ALT.	SUS	REV	DATE	ALT.	SUS	DEPT	UN.	TOL.	DIM.	GR.	SCALE	WEIGHT (KG.)	REF TO ASSY	ITEM NO.	NO. OF ITEMS
02	22.08.07	CKD.	SSA	01	17.08.07	CKD.	SSA	SWE					1:1		35211001721	001T	007
		APPD.	DIVYA			APPD.	ANITA	CODE								003	
	VAR. 03 & SHT. 05 ADDED.				DRG. CORRECTED. & REDRAWN.			TITLE				JAW BODY		DRG NO	3 521 10 01723		REV.
	(DCA NO. 26964)				(DCA NO. 26951)							SHT.NO.	04	NO. OF SHT.	05		02

THE INFORMATION ON THIS DOCUMENT IS THE PROPERTY OF BHARAT HEAVY ELECTRICALS LIMITED. IT MUST NOT BE USED DIRECTLY OR INDIRECTLY IN ANY WAY DETRIMENTAL TO THE INTEREST OF THE COMPANY.

35211001723-R02-S05
REF.DRG.NO.

SIGN. & DATE

INVENTORY NO.

DRG NO 3 521 10 01 723

NOTE :-

- ITEM 1,2, & 3 ARE TO BE RIVETTED AS SHOWN. RIVETTED SURFACE TO BE COVERED WITH ANTI RUST VARNISH.

VAR. 03	VAR. 02	VAR. 01	VAR 00	REMARKS	VAR NO.	ITEM NO.	DESCRIPTION	STD	DRAWING NO.	IT.NO.	MATERIAL CODE	A	UNIT	UNIT WT.
										VAR	MATL. SPCN.	C		QTY
-	002	-	-			007	LINK		35211001726	002				0.016
														001
002	-	002	002			006	LINK		35211001726	001				0.021
														001
-	002	-	-			005	SHUTTER		35211001728	002				0.040
														001
002	-	002	002			004	SHUTTER		35211001728	001				0.052
														001
002	002	-	-			003	SIDE SHEET		35211001725	003				0.082
														001
-	-	002	-			002	SIDE SHEET		35211001725	002				0.087
														001
-	-	-	002			001	SIDE SHEET		35211001725	001				0.092
														001

ADDITIONAL INFORMATION				TYPE OF PRODUCT OR NAME OF CUST/PROJ				VM-12 (BT-II)																									
STATUS OF DRAWING				 BHARAT HEAVY ELECTRICALS LIMITED BHOPAL				NAME		SIGN		DATE		NO. OF VAR																			
DISTRIBUTION OF PRINTS								DRN		SSA		D.BHATT		22.08.07		04																	
कार्यालय प्रति ---- 1 दस. डब्ल्यू. दम. - 3 टी. सी. दवेस. ---- 1								CKD		SSA		D.BHATT		22.08.07		04																	
REV 02		DATE 22.08.07		ALT. SUS		CKD. SSA		APPD. DIVYA		REV 01		DATE 17.08.07		DRN SUS		CKD SSA		APPD ANITA		DEPT SWE		UN. TOL.DIMGR.		SCALE 1:1		WEIGHT (KG.)		REF TO ASSY		ITEM NO.		NO. OF ITEMS	
		VAR. 03 & SHT. 05 ADDED.				DRG. CORRECTED. & REDRAWN.								35211001721		001		003		409						35211001721		003		007			
				TITLE				JAW BODY				DRG NO				3 521 10 01723				REV. 02													
												SHT.NO. 05				NO. OF SHT. 05																	

(DCA NO. 26964)

(DCA NO. 26951)

INVENTORY No. 35211001724-R01-S01
 SIGN. & DATE
 REF. DRG. NO. 35211001724-R01-S01
 THE INFORMATION ON THIS DOCUMENT IS THE PROPERTY OF BHARAT HEAVY ELECTRICALS LIMITED. IT MUST NOT BE USED DIRECTLY OR INDIRECTLY IN ANY WAY DETRIMENTAL TO THE INTEREST OF THE COMPANY.

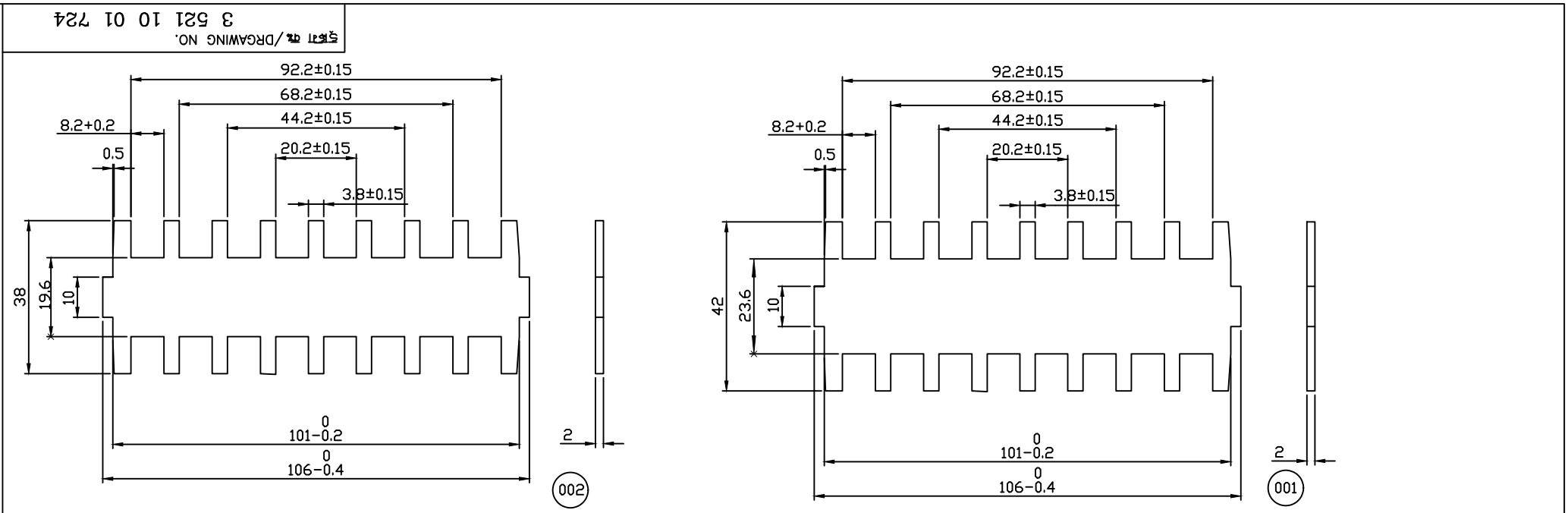

VAR. NO.	REMARKS	VAR. NO.	ITEM NO.	DESCRIPTION	STD.	DRAWING NO.	IT. NO.	MATL. CODE.	A	C	UNIT	UNIT WT.	GS.
			004	2TK.X34X106 LG H.R.C.S. SHEET.				AA 1011713110				0.0566	
								AA 10113				001	
			003	2TK.X34X82 LG H.R.C.S. SHEET.				AA 1011713110				0.036	
								AA 10113				001	
			002	2TK. x38x106 LG H.R.C.S. SHEET.				AA 1011713110				0.052	
								AA 10113				001	
			001	2TK. x42x106 LG H.R.C.S. SHEET.				AA 1011713110				0.057	
								AA 10113				001	
							VAR	MATL. SPCN.				QTY.	

ADDITIONAL INFORMATION STATUS OF DRAWING DISTRIBUTION OF PRINTS OFFICE COPY - 1 SWM - 3 TCX (SWM) - 1		TYPE OF PRODUCT OR NAME OF CUSTOMER/PROJECT VM-12 (BT-II)	
REV 01 DATE 22.08.07 ALTERED CHECKED APPROVED SUS SSA DIVYA		विभाग DEPT. SWE कोड CODE. 409 अन.टोल.नाप की त्रुटि UNTO. DIMS. GR. भार क. ग. WEIGHT (K.G.) अनुपात SCALE 1:1	
ITEM 004 & SHT. 02 ADDED. (DCA NO. 26963)		BHARAT HEAVY ELECTRICALS LTD. BHOPAL नाम / NAME G.PRASAD हस्ता / SIGN. S.S.A. दि. / DATE 07.04.01 ड्राइंग का संदर्भ REF. TO ASSY. 35211001721 मद संख्या / ITEM NO. 004 मद संख्या / ITEM NO. 006 ड्राइंग क्र. / DRGAWING NO. 3 521 10 01 724 पुन. / REV. 01 शीट क्र. / SHT.NO 01 शीटों की सं. / NO.OF.SHT. 02	
		SHUTTER	

35211001724-R01-S02
REF. DRG. NO.

SIGN. & DATE

INVENTORY No.

3 521 10 01 724
ड्रॉइंग नं./DRGAWING NO.

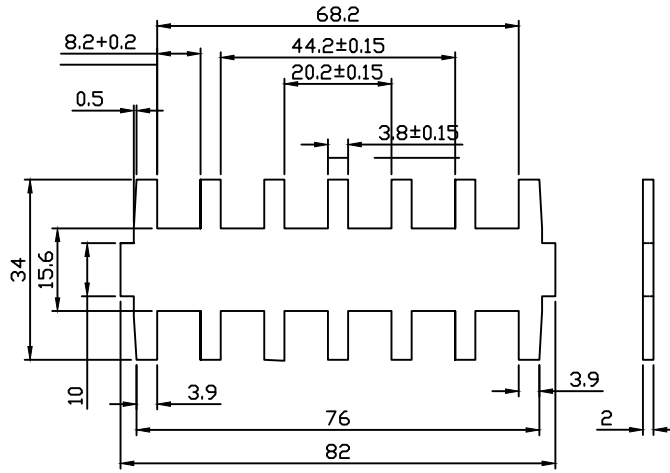

003

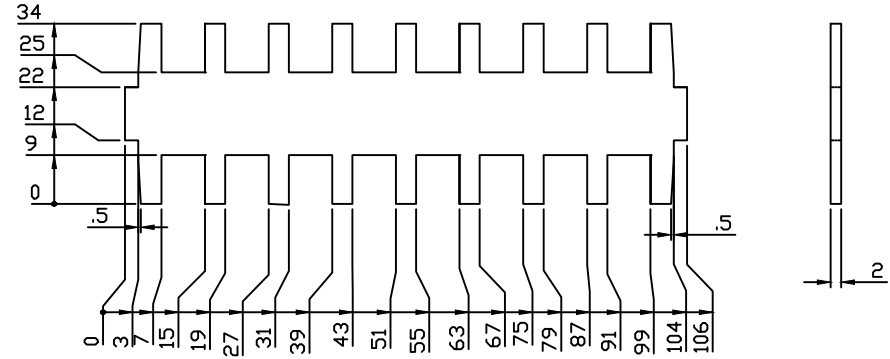

004

UNSPECIFIED TOLERANCES SHALL BE :-
FOR MACHINING MEDIUM AA0230208.
FOR SHEARING OF SHEETS AS PER AA0230409.

FINISH:-

ZINC PLATE & PASSIVATE TO AA0673603 & AA0673604.
(0.013 TK. MIN.)

OLD DRG-35964011102

ADDITIONAL INFORMATION		TYPE OF PRODUCT OR VM-12 (BT-II)								
STATUS OF DRAWING		NAME OF CUSTOMER/PROJECT								
DISTRIBUTION OF PRINTS		BHARAT HEAVY ELECTRICALS LTD. BHOPAL		खनपा DRN.	नाम /NAME	हस्ता/SIGN.	दि./DATE	ड्रॉइंग की संख्या NO. OF VAR.		
OFFICE COPY - 1				जॉया CKD.	SUS		22.08.07			
SWM - 3				स्विकृत APPD.	SSA		22.08.07			
TCX (SWM) - 1				D.BHATT		22.08.07				
REV	DATE	ALTERED	SUS	विभाग DEPT. SWE	अन.टोल.नाप की त्रुटि UNTOL. DIMS. GR.	अनुपात SCALE	भार का ग्रा. WEIGHT (K.G.)	उसे. ड्रॉइंग का संदर्भ REF. TO ASSY.	मद संख्या ITEM NO.	मद संख्या NO. OF ITEM
01	22.08.07	CHECKED	SSA	कोड CODE. 409		1:1				004
ITEM 004 & SHT. 02 ADDED.				/TITLE SHUTTER				ड्रॉइंग नं./DRGAWING NO.		पुन./ REV.
(DCA NO. 26963)								3 521 10 01 724		01
				शीट नं./SHT.NO 02				शीटों की सं./NO.OF.SHT. 02		

THE INFORMATION ON THIS DOCUMENT IS THE PROPERTY OF BHARAT HEAVY ELECTRICALS LIMITED. IT MUST NOT BE USED DIRECTLY OR INDIRECTLY IN ANY WAY DETRIMENTAL TO THE INTEREST OF THE COMPANY.

35211001725-R00-S01
REF.DRG.NO.

SIGN. & DATE

INVENTORY NO.

DRG NO 3 521 10 01 725

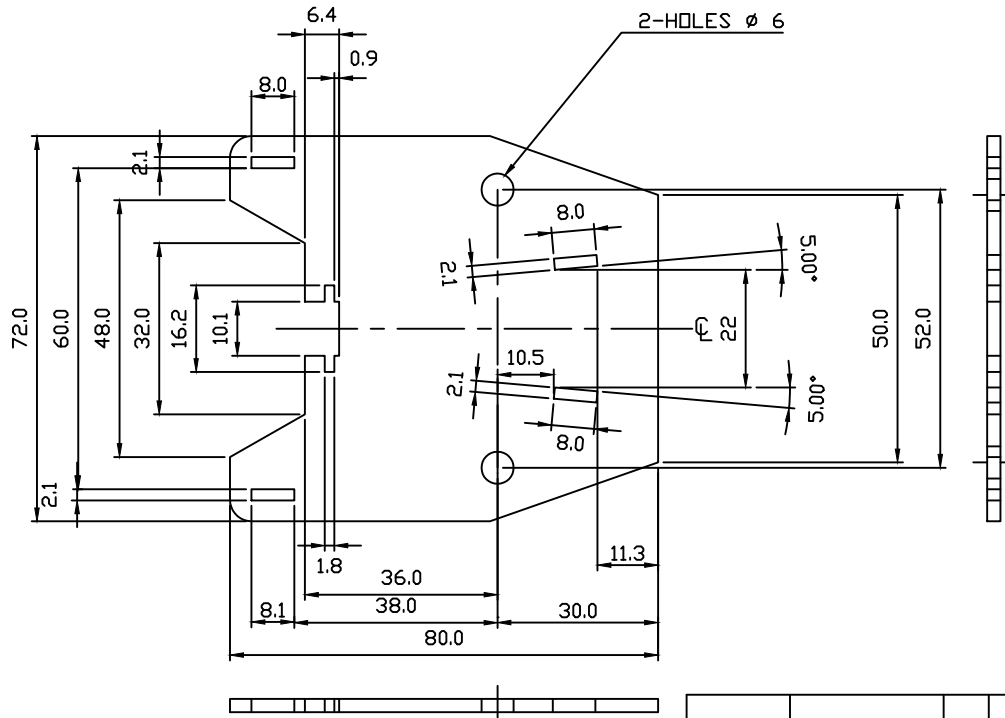

001

UNSPECIFIED TOLERANCES SHALL BE :-
FOR MACHINING MEDIUM AA0230208.
FOR SHEARING OF PLATES/SHEETS AS PER AA0230409.

FINISH :-
ZINC PLATE & PASSIVATE TO AA0673603 & AA0673604.
(0.013 TK. MIN.)

NOTES :-
TOLERANCE ±0.2 UNLESS OTHER WISE STATED

OLD REF.-35964011111

VAR 00	REMARKS	VAR NO.	ITEM NO.	DESCRIPTION	STD	DRAWING NO.	IT.ND.	MATERIAL CODE	A	UNIT	UNIT WT.
							VAR	MATL. SPCN.	C		QTY
			003	2.5TK. x 64 x 80 LG. HRC.STL.SH.PICKLED				BP 10117198026			0.092
								BP 10198			001
			002	2.5TK. x 68 x 80 LG. HRC.STL.SH.PICKLED				BP 10117198026			0.092
								BP 10198			001
			001	2.5TK. x 72 x 80 LG. HRC.STL.SH.PICKLED				BP 10117198026			0.092
								BP 10198			001

ADDITIONAL INFORMATION				TYPE OF PRODUCT OR NAME OF CUST/PROJ		VM-12(BT.II)						
STATUS OF DRAWING				NAME		SIGN	DATE	NO. OF VAR				
DISTRIBUTION OF PRINTS				DRN								
				CKD								
				APPD								
B				G.PRASAD			07.04.01	-				
कार्यालय प्रति ---- 1 दस. डबल्यू. दम. - 3 टी. सी. दवेस. ---- 1				S.S.A.			29.05.01					
				D.BHATT			29.05.01					
REV	DATE	DRN	DEPT	UN. TOL.DIMGR.	SCALE	WEIGHT (KG.)	REF TO ASSY	ITEM NO.	NO. OF ITEMS			
		CKD	SWE		1:1		3521001723	001	003			
		APPD	409				3521001723	003				
TITLE							DRG NO	REV.				
SIDE SHEET							3 521 10 01 725	00				
							SHT.NO.	01	NO. OF SHT.	03		

THE INFORMATION ON THIS DOCUMENT IS THE PROPERTY OF BHARAT HEAVY ELECTRICALS LIMITED. IT MUST NOT BE USED DIRECTLY OR INDIRECTLY IN ANY WAY DETRIMENTAL TO THE INTEREST OF THE COMPANY.

35211001725-R00-S02
REF.DRG.NO.

SIGN. & DATE

INVENTORY NO.

DRG NO 3 521 10 01 725

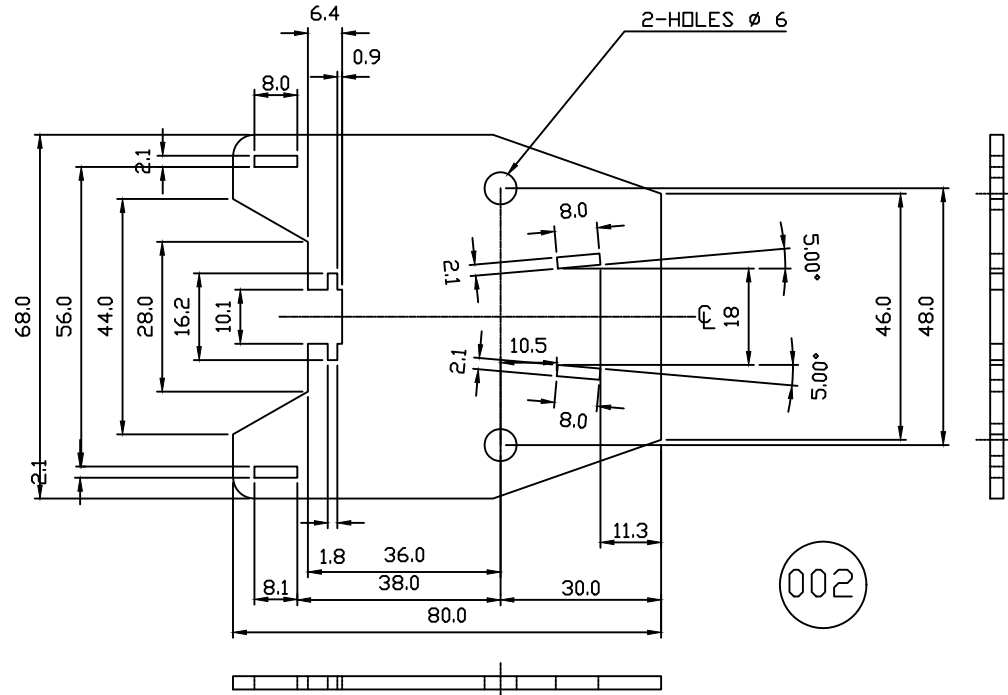

VAR NO	REMARKS	VAR NO.	ITEM NO.	DESCRIPTION	STD	DRAWING NO.	IT.ND.	MATERIAL CODE	A	UNIT	UNIT WT.
							VAR	MATL. SPCN.	C		QTY

ADDITIONAL INFORMATION				TYPE OF PRODUCT OR NAME OF CUST/PROJ								VM-12			
STATUS OF DRAWING				DISTRIBUTION OF PRINTS				Bharat Heavy Electricals Limited Bhopal				NAME SIGN DATE NO. OF VAR			
U				कार्यालय प्रति ---- 1 एस. डब्ल्यू. एम. - 3 टी. सी. एच.एस. ---- 1				DRN G.PRASAD 07.04.01 CKD S.S.A. 29.05.01 APPD D.BHATT 29.05.01				-			
REV	DATE	DRN	DEPT	SWE	UN. TOL.DIMGR.	SCALE	WEIGHT (KG.)	REF TO ASSY				ITEM	NO. OF		
		CKD	409			1:1		3521001723				MP. 001	ITEMS 003		
TITLE								DRG NO				REV.			
SIDE SHEET								3 521 10 01 725				00			
								SHT.NO.	02	NO. OF SHT.		03			

THE INFORMATION ON THIS DOCUMENT IS THE PROPERTY OF BHARAT HEAVY ELECTRICALS LIMITED. IT MUST NOT BE USED DIRECTLY OR INDIRECTLY IN ANY WAY DETRIMENTAL TO THE INTEREST OF THE COMPANY.

35211001725-R00-S03
REF.DRG.NO.

SIGN. & DATE

INVENTORY NO.

DRG NO 3 521 10 01 725

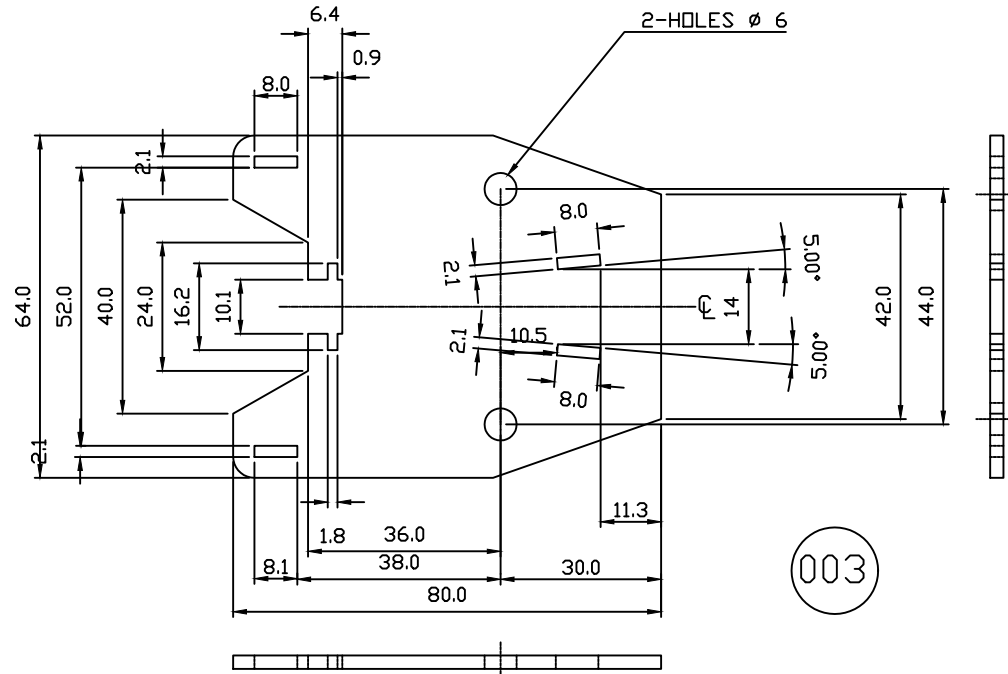

VAR 00	REMARKS	VAR NO.	ITEM NO.	DESCRIPTION	STD	DRAWING NO.	IT.ND.	MATERIAL CODE	A	UNIT	UNIT WT.
							VAR	MATL. SPCN.	C		QTY

ADDITIONAL INFORMATION				TYPE OF PRODUCT OR NAME OF CUST/PROJ								VM-12(BT-2)			
STATUS OF DRAWING 'U'				 BHARAT HEAVY ELECTRICALS LIMITED BHOPAL				DRN	NAME	SIGN	DATE	NO. OF VAR			
DISTRIBUTION OF PRINTS								CKD	S.S.A.		29.05.01	-			
कार्यालय प्रति ---- 1 दस डब्ल्यू. दम. - 3 टी. सी. दवेस. ---- 1								APPD	D.BHATT		29.05.01	-			
REV	DATE	DRN	DEPT	UN. TOL.DIMGR.	SCALE	WEIGHT (KG.)	REF TO ASSY	ITEM	NO. OF ITEMS						
		CKD	SWE		1:1		3521001723	MP. 001	003						
		APPD	CODE				DRG NO	003	REV.						
			409				3 521 10 01 725		00						
TITLE							SHT.NO.	03	NO. OF SHT.	03					
SIDE SHEET															

THE INFORMATION ON THIS DOCUMENT IS THE PROPERTY OF BHARAT HEAVY ELECTRICALS LIMITED. IT MUST NOT BE USED DIRECTLY OR INDIRECTLY IN ANY WAY DETRIMENTAL TO THE INTEREST OF THE COMPANY.

35211001726-R00-S01
REF. DRG. NO.

SIGN. & DATE

INVENTORY No.

3 521 10 01 726
DRAWING NO./कॉपी नं.

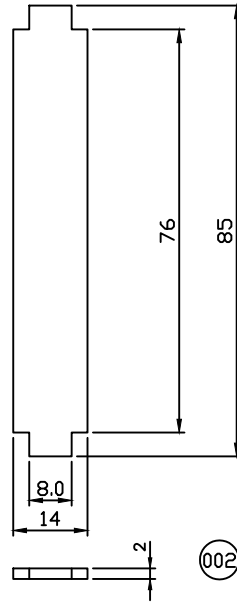
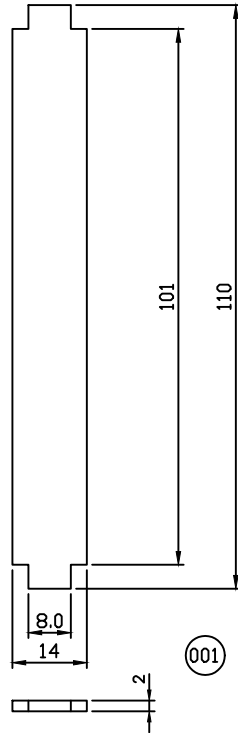

UNSPECIFIED TOLERANCES SHALL BE :-
FOR MACHINING MEDIUM AA0230208.
FOR SHEARING OF SHEETS AS PER AA0230409.

FINISH:-

ZINC PLATE & PASSIVATE TO AA0673603 & AA0673604.
(0.013 TK. MIN.)

OLD.DRG.-35964011114

VAR. NO.	REMARKS	VAR. NO.	ITEM NO.	DESCRIPTION	STD.	DRAWING NO.	IT. NO.	MATL. CODE.	A	C	UNIT	UNIT WT.	GS.
			002	2TKx14x 85.2 LG H.R.S. SHEET				AA 1011713110				0.016	
								AA 10113				001	
			001	2TKx14x 110 LG H.R.C.S. SHEET				AA 1011713110				0.021	
								AA 10113				001	
							VAR	MATL. SPCN.				QTY.	

ADDITIONAL INFORMATION

STATUS OF DRAWING

DISTRIBUTION OF PRINTS

OFFICE COPY - 1
SWGR SHOPS - 3
TCX BLIV - 1

REV DATE ALTERED
CHECKED
APPROVED

TYPE OF PRODUCT OR

VM-12

NAME OF CUSTOMER/PROJECT



BHARAT HEAVY ELECTRICALS LTD.
BHOPAL

खनाया DRN.	नाम /NAME	हस्ता/SIGN.	दि./DATE	वे.ि की संख्या NO. OF VAR.
G.PRASAD			07.04.01	
S.S.A.			29.05.01	
D.BHATT			29.05.01	

विभाग
DEPT. SWE

अन.टल.माप की त्रुटि
UNTOL. DIMS. GR.

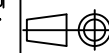

अनुपात
SCALE

1:1

भार. कि. ग्रा.
WEIGHT (K.G.)

असे. ड्रॉइंग का संदर्भ
REF. TO ASSY.

3521001723

मद संख्या
ITEM NO.

006 & 007

मद संख्या
NO. OF
ITEM

002

/TITLE

LINK

ड्रॉइंग क्र./DRGAWING NO.

3 521 10 01 726

पुन./
REV.

00

शीट क्र./SHT.NO 101

शीटों की सं./NO.OF.SHT.1 01

3 521 10 01 727
ON DRG/DRG NO. 3 521 10 01 727

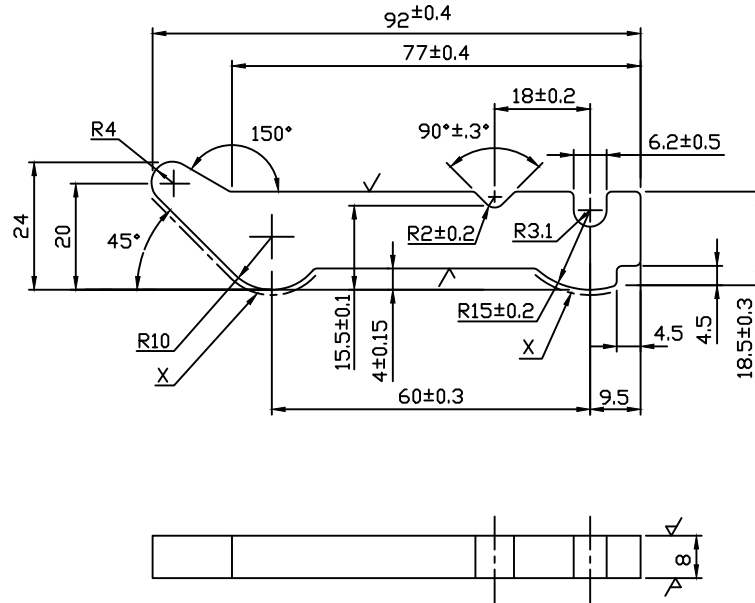

001 002

UNSPECIFIED TOLERANCES SHALL BE :-
FOR MACHINING MEDIUM AA0230208.
FOR SHEARING OF PLATES AS PER AA0230409.

NOTE :-

- WHEREEVER RADIUS IS NOT GIVEN TAKE R=1.6
- SURFACES MARKED 'X' THUS ARE TO BE OF 6 MICRONS FINISH.
- ALL THE SHARP CORNERS ARE TO BE ROUNDED OFF BY 1mm. EXCEPT MARKED THUS 'X'
- FINISH :-
A- IT. 001:- SILVER PLATE (0.13TK.) TO PROCESS SPEC. NO.0673613.
B- IT. 002:- TIN PLATED TO (0.020TK.) PROCESS SPEC. NO. AA 0673602.
C- SURFACE AREA :- 6670 SQ.MM.

OLD DRG.-35964011101

VAR. NO.	REMARKS	VAR. NO.	ITEM NO.	DESCRIPTION	QTY.	DRAWING NO.	IT. NO.	MATL. CODE.	A	UNIT	UNIT WT.	GS.
			002	8TK. x 25 x 92LG. HARD COPPER STRIP	1			AA 1201903138			0.094	
								AA 12003			001	
			001	8TK. x 25 x 92LG. HARD COPPER STRIP	1			AA 1201903138			0.094	
								AA 12003			001	

INVENTORY No. 35211001727-R00-S01 REF. DRG. NO. THE INFORMATION ON THIS DOCUMENT IS THE PROPERTY OF BHARAT HEAVY ELECTRICALS LIMITED. IT MUST NOT BE USED DIRECTLY OR INDIRECTLY IN ANY WAY DETRIMENTAL TO THE INTEREST OF THE COMPANY.

ADDITIONAL INFORMATION				TYPE OF PRODUCT OR NAME OF CUSTOMER/PROJECT									
STATUS OF DRAWING				VM12									
DISTRIBUTION OF PRINTS				BHARAT HEAVY ELECTRICALS LTD. BHOPAL				खनपा DRN. G.PRASAD जाँचा CKD. SSA स्विकृत APPD. D.BHATT		हस्ता/SIGN. Sd/- दि./DATE 07-04-01 28-05-01 28-05-01		पैरि की संख्या NO. OF VAR.	
REV	DATE	ALTERED	P.PARE	विभाग DEPT. SWE	अन.टोल.नाप की त्रुटि UN.TOL. DIMS. GR.	अनुपात SCALE	भार कि. ग्र. WEIGHT (K.G.)	उसे. ड्रॉइंग का संदर्भ REF. TO ASSY.	मद संख्या ITEM NO.	मद संख्या NO. OF ITEM			
01	11.08.10	CHECKED	AKHIL	कोड CODE. 409		NTS		35211001721	008 & 009	002			
ACTUAL FINISHED WEIGHT OF COPPER UPDATED.				/TITLE				ड्रॉइंग क्र./DRGAWING NO.		पुन./REV.			
(DCA 29920)				JAW CONTACT				3 521 10 01727		00			
								शीट क्र./SHT.NO 01		शीटों की सं./NO.OF.SHT. 01			

THE INFORMATION ON THIS DOCUMENT IS THE PROPERTY OF BHARAT HEAVY ELECTRICALS LIMITED. IT MUST NOT BE USED DIRECTLY OR INDIRECTLY IN ANY WAY DETRIMENTAL TO THE INTEREST OF THE COMPANY.

DRG NO 3 521 10 01 728

UNSPECIFIED TOLERANCES SHALL BE :-
FOR MACHINING MEDIUM AA0230208.
FOR SHEARING OF SHEETS AS PER AA0230409.

FINISH:-

ZINC PLATE & PASSIVATE TO AA0673603 & AA0673604.
(0.013 TK. MIN.)

REF DRG.-35964011112

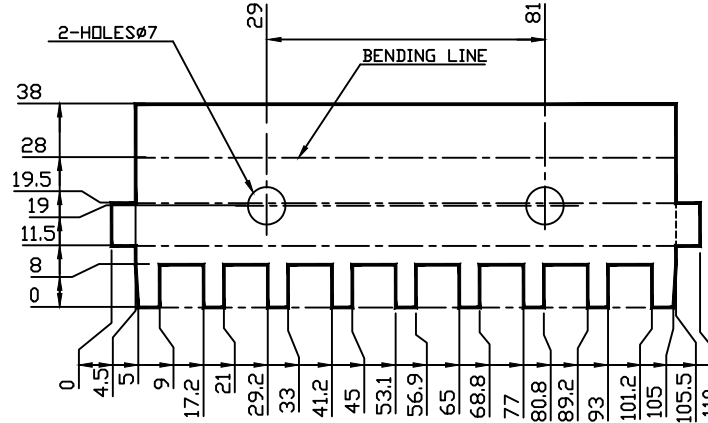
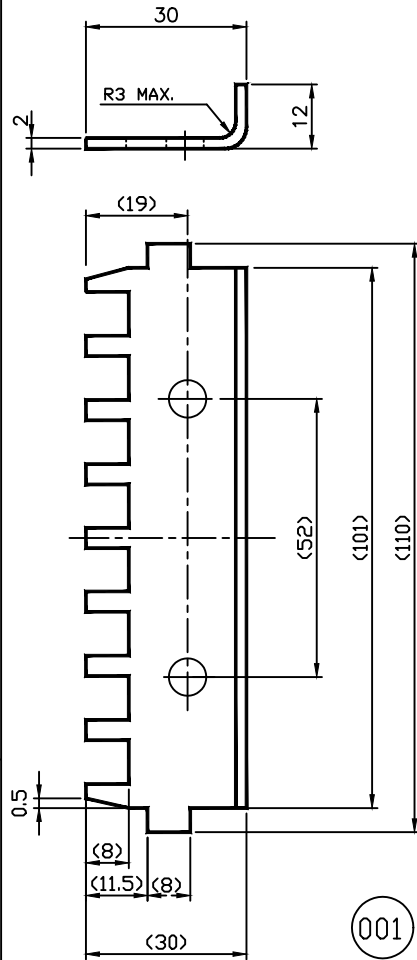

DEVELOPMENT OF ITEM-001

-	-	001	2TK. x 38 x 110 LG. H.R.C. STEEL SHEET		AA 1011713110		0.052
VAR 00	REMARKS	VAR NO.	ITEM NO.	DESCRIPTION	STD	DRAWING NO.	UNIT
						IT.NO.	MATERIAL CODE
						VAR	MATL. SPCN.
						A	UNIT
						C	UNIT WT.
							QTY

35211001728-R00-S01
REF.DRG.NO.

SIGN. & DATE

INVENTORY NO.

ADDITIONAL INFORMATION			TYPE OF PRODUCT OR NAME OF CUST/PROJ		VM-12				
STATUS OF DRAWING			DISTRIBUTION OF PRINTS		Bharat Heavy Electricals Limited Bhopal		NAME SIGN DATE		
कार्यालय प्रति ---- 1			दस. डबल्यू. दम. - 3		DRN G.PRASAD		07.04.01		
टी. सी. दवेस. ---- 1					CKD S.S.A.		29.05.01		
					APPD D.BHATT		29.05.01		
REV	DATE	DRN CKD APPD	DEPT SWE CODE	UN. TOL.DIMGR.	SCALE	WEIGHT (KG.)	REF TO ASSY	ITEM NO.	NO.OF ITEMS
			409		1:1		35211001723	004 & 005	002
TITLE							DRG NO		REV.
SHUTTER							3 521 10 01 728		00
							SHT.NO.	01	NO.OF SHT.
									02

THE INFORMATION ON THIS DOCUMENT IS THE PROPERTY OF BHARAT HEAVY ELECTRICALS LIMITED. IT MUST NOT BE USED DIRECTLY OR INDIRECTLY IN ANY WAY DETRIMENTAL TO THE INTEREST OF THE COMPANY.

35211001728-R00-S02
REF.DRG.NO.

SIGN. & DATE

INVENTORY NO.

DRG NO 3 521 10 01 728

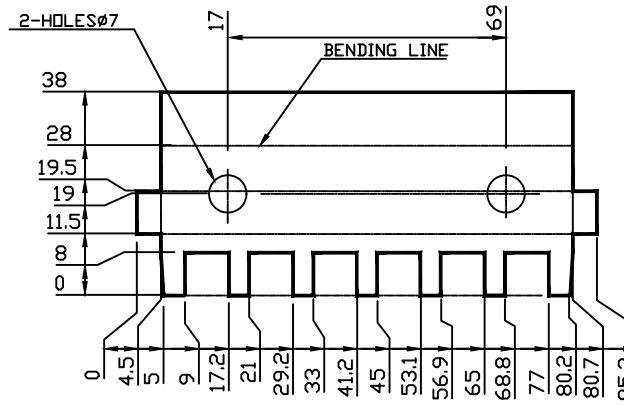
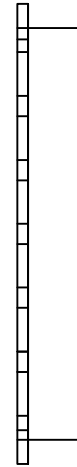
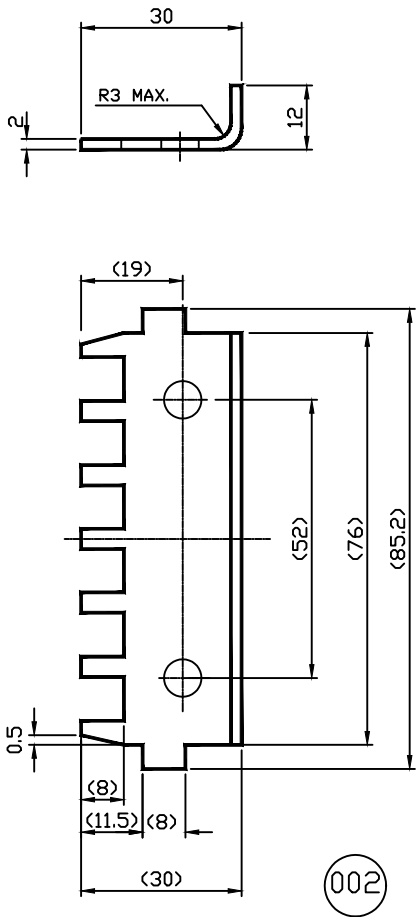

DEVELOPMENT OF ITEM-002

UNSPECIFIED TOLERANCES SHALL BE :-
FOR MACHINING MEDIUM AA0230208.
FOR SHEARING OF SHEETS AS PER AA0230409.

FINISH:-

ZINC PLATE & PASSIVATE TO AA0673603 & AA0673604.
(0.013 TK. MIN.)

REF DRG.-35964011112

-	-	002	2TK. x 38 x 85.2 LG. H.R.C. STEEL SHEET			AA 1011713110		0.052
VAR 00	REMARKS	VAR NO.	ITEM NO.	DESCRIPTION	STD	DRAWING NO.	IT.NO. MATERIAL CODE	UNIT WT.
							AA 10113	001
							VAR MATL. SPCN.	QTY

ADDITIONAL INFORMATION			TYPE OF PRODUCT OR NAME OF CUST/PROJ		VM-12 (BT-II)						
STATUS OF DRAWING			DISTRIBUTION OF PRINTS		Bharat Heavy Electricals Limited Bhopal		DRN	NAME	SIGN	DATE	NO. OF VAR
कार्यालय प्रति ---- 1			दस. डब्ल्यू. दम. - 3		D.BHATT		CKD	S.S.A.		07.04.01	
टी. सी. दवेस. ---- 1							APPD			29.05.01	
REV	DATE	DRN	DEPT	UN. TOL.DIMGR.	SCALE	WEIGHT (KG.)	REF TO ASSY	ITEM NO.	NO. OF ITEMS		
		CKD	SWE		1:1		35211001723	004 & 005	002		
		APPD	CODE				DRG NO			REV.	
			409				3 521 10 01 728			00	
TITLE							SHT.NO.	02	NO. OF SHT.	02	
SHUTTER											

3 521 10 01 729 3
ON DRGAWING/DRGAWING NO.

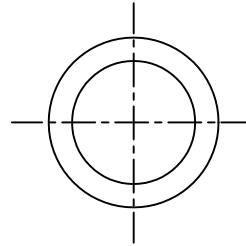
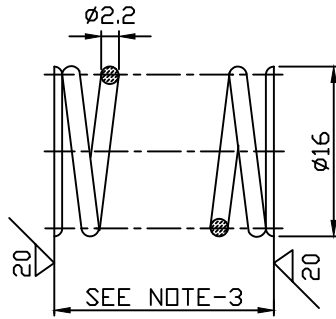

PARTICULARS	NOM.	MIN.	MAX.
GRADE	C		
INSIDE DIA.	11.6 *		
OUTSIDE DIA.			16.0
DIRECTION OF WDG.	R.H.		
TOTAL TURNS	6.5		
FREE LENGTH	SEE NOTE-3		
NO. OF ACTIVE TURNS	4.5 *		
SCALE Kg/mm.	2		
MOVEMENT			

FINISH :- ZINC PLATE & PASSIVATE TO (0.013TK. TO 0.015TK.)
PROCESS SPEC. NO. AA0673603 & AA0673604.

NOTES-

1. TOLERANCE ON LOAD ±10%
2. DATA MARKED THUS * ARE ONLY FOR REFERENCE.
3. FREE LENGTH TO BE GRINDED 27.6 FOR IT. 001 & IT. 002 AND 27.0 FOR IT. 003.

OLD DRG.-35964011103

VAR. 00	REMARKS	VAR. NO.	ITEM NO.	DESCRIPTION	STD.	DRAWING NO.	IT. NO.	MATL. CODE.	A	C	UNIT	UNIT WT.	GS.
			003	2.2 DIA.x290LG. COLD DRAWN SPG'S WIRE								0.002	
								AA 10301				001	
			002	2.2 DIA.x290LG. COLD DRAWN SPG'S WIRE								0.002	
								AA 10301				001	
			001	2.2 DIA.x290LG. COLD DRAWN SPG'S WIRE								0.002	
								AA 10301				001	
							VAR	MATL. SPCN.				QTY.	

INVENTORY No. SIGN. & DATE REF. DRG. NO. 35211001729-R01-S01
 THE INFORMATION ON THIS DOCUMENT IS THE PROPERTY OF BHARAT HEAVY ELECTRICALS LIMITED. IT MUST NOT BE USED DIRECTLY OR INDIRECTLY IN ANY WAY DETRIMENTAL TO THE INTEREST OF THE COMPANY.

ADDITIONAL INFORMATION			TYPE OF PRODUCT OR NAME OF CUSTOMER/PROJECT									
STATUS OF DRAWING			VM-12									
DISTRIBUTION OF PRINTS			 BHARAT HEAVY ELECTRICALS LTD. BHOPAL				खनाया DRN. G.PRASAD नाम /NAME हस्ता/SIGN.		दि./DATE 07.04.01 वेरि की संख्या NO. OF VAR.			
OFFICE COPY - 1			विभाग DEPT. SWE कोड CODE. 409 अनुपात SCALE NTS भार क. ग. WEIGHT (K.G.)				जांचा CKD. S.S.A. नाम /NAME		दि./DATE 29.05.01 वेरि की संख्या NO. OF VAR.			
SWGER SHOP -3							स्विकृत APPD. D.BHATT नाम /NAME		दि./DATE 29.05.01 वेरि की संख्या NO. OF VAR.			
TCX BLIV -1							मर सख्या NO. OF ITEM 016T मर सख्या NO. OF ITEM 018		मर सख्या NO. OF ITEM 003			
REV 01	DATE 07.12.04	ALTERED CHECKED APPROVED RM	/TITLE				असे. ड्रॉइंग का संदर्भ REF. TO ASSY. 3521001721 मर सख्या NO. OF ITEM 018					
BP CODE ADDED			/TITLE				ड्रॉइंग क्र./DRGAWING NO. 3 521 10 01 729 पुन./REV. 01					
(DCA-21485)			/TITLE				शीट क्र /SHT.NO 01 शीटों की सं./NO.OF.SHT. 01					
			SPRING									

INVENTORY No. SIGN. & DATE REF. DRG. NO. 35211001731-R00-S01
 THE INFORMATION ON THIS DOCUMENT IS THE PROPERTY OF BHARAT HEAVY ELECTRICALS LIMITED. IT MUST NOT BE USED DIRECTLY OR INDIRECTLY IN ANY WAY DETRIMENTAL TO THE INTEREST OF THE COMPANY.

3 521 10 01 731
 ON DRAWING NO.

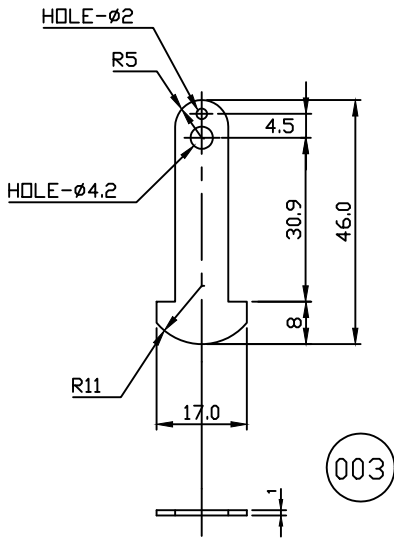
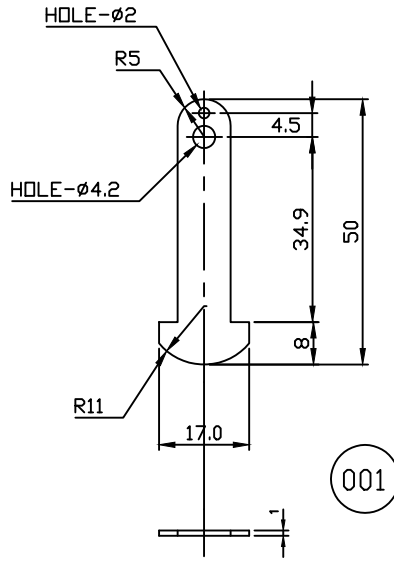
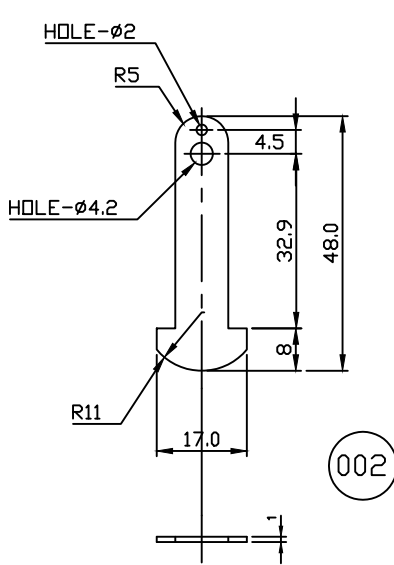

UNSPECIFIED TOLERANCES SHALL BE :-
 FOR MACHINING MEDIUM AA0230208.
 FOR SHEARING OF SHEETS AS PER AA0230409.

FINISH :-
 ZINC PLATE & PASSIVATE TO (0.013TK.MIN.)
 PROCESS SPEC. NO. AA0673603 & AA0673604.

NOTES:-
 ITEM-001 FOR 20-TK CONNECTOR
 ITEM-002 FOR 16-TK CONNECTOR
 ITEM-003 FOR 12-TK CONNECTOR

OLD DRG.35964011105

VAR. NO.	REMARKS	VAR. NO.	ITEM NO.	DESCRIPTION	STD.	DRAWING NO.	IT. NO.	MATL. CODE.	A	UNIT	UNIT WT.	GS.
VAR.							VAR	MATL. SPCN.	C		QTY.	
			003	1TKx17x 46 LG CRS SHEET				AA 1011715074			0.004	
								AA 10115			001	
			002	1TKx17x 48 LG CRS SHEET				AA 1011715074			0.004	
								AA 10115			001	
			001	1TKx17x 50 LG CRS STEEL SH.				AA 1011715074			0.004	
								AA 10115			001	

ADDITIONAL INFORMATION

STATUS OF DRAWING B

DISTRIBUTION OF PRINTS

OFFICE COPY - 1
 SWM - 3
 TCX -BL. IV - 1

REV	DATE	ALTERED
		CHECKED
		APPROVED

TYPE OF PRODUCT OR

NAME OF CUSTOMER/PROJECT

VM-12(BT-2)



BHARAT HEAVY ELECTRICALS LTD.
BHOPAL

खनक्या DRN.	नाम /NAME	हस्ता/SIGN.	दि./DATE	वै.ि की संख्या NO. OF VAR.
	G.PRASAD		07-04-01	
	SSA		29-05-01	
	D.BHATT		29-05-01	

विभाग DEPT. SWE
 कोड CODE. 409
 अन्.टल.नाप की त्रेण UNTOL. DIMS. GR.
 REF CG 06503
 अनुपात SCALE 2:1
 भार के.ग. WEIGHT (K.G.)

असे. ड्रॉइंग का संदर्भ REF. TO ASSY.
 35211001721
 मद संख्या ITEM NO. 013 TO 015
 मद संख्या NO. OF ITEM 003

/TITLE

SPRING PULL ROD

ड्रॉइंग क्र./DRGAWING NO. 3 521 10 01 731
 पुन./REV. 00
 शीट क्र./SHT.NO 01 शीटों की सं./NO.OF.SHT. 01

THE INFORMATION ON THIS DOCUMENT IS THE PROPERTY OF BHARAT HEAVY ELECTRICALS LIMITED IT MUST NOT BE USED DIRECTLY OR INDIRECTLY IN ANY WAY DETRIMENTAL TO THE INTEREST OF THE COMPANY

DRG. NO. 3 521 10 01734

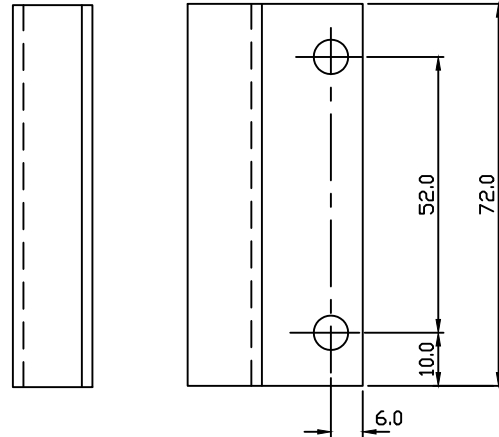
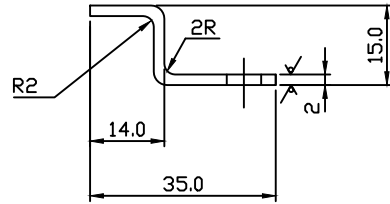

ITEM 001

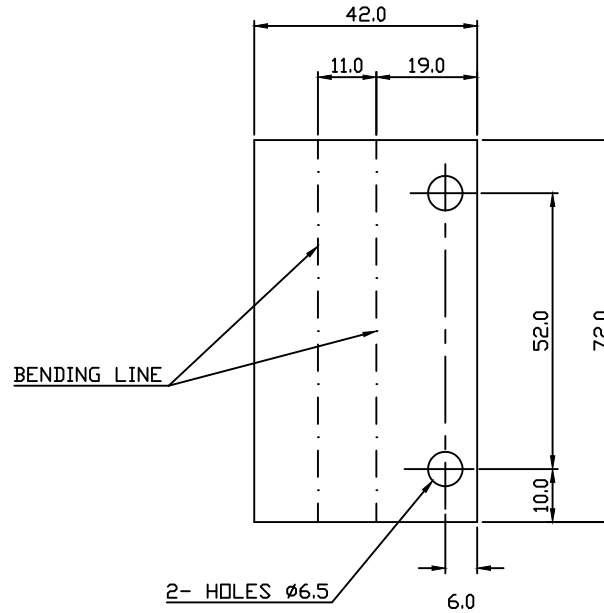

DEVELOPMENT OF ITEM 001

UNSPECIFIED TOLERANCES SHALL BE :-
 FOR MACHINING MEDIUM AA0230208.
 FOR SHEARING OF SHEETS AS PER AA0230409.
 FINISH :-
 ZINC PLATE & PASSIVATE TO AA0673603 AND
 AA0673604 (0.013 TK. MIN.)

OLD DRG.35964011030

VAR00	65	75	78	79	25	27	29	58	59	60	77	29	31	34	45	55	58	65	72
REMARKS					VAR. NO.	ITEM NO.	DESCRIPTION	STD	DRAWING NO.	IT.ND.	MATL. CODE	UNIT WT.	QTY.	ZONE					
					002		2TK X 42X50 LG. H.R.C.S.SHEET			AA1011713110	0.033								
					001		2TK X 42X72 LG. H.R.C.S.SHEET			AA1011713110	0.0475								

INVENTORY NO. SIGN. & DATE REF. DRG. NO.

ADDITIONAL INFORMATION

STATUS OF DRAWING

DISTRIBUTION OF PRINTS

O.COPY-----1
 SWM-----3
 TCX-----1

उत्पाद का प्रकार या
 ग्राहक/परियोजना का नाम
 TYPE OF PRODUCT OR
 NAME OF CUSTOMER/PROJECT
VM-12 (BT2)



भारत हेवी इलेक्ट्रिकल्स लिमिटेड
 भोपाल
 BHARAT HEAVY ELECTRICALS LTD.
 BHOPAL

क्रमांक DRN	नाम/NAME	हस्ता/ SIGN	दिनांक/ DATE	वे.र. की संख्या NO. OF VAR
	G.PRASAD		07.04.01	
जेंचा CKD	S.S.A		29.12.01	
अनुमोदित APPD	D.BHATT		29.05.01	

REV.	DATE	ALTERED	SUS
01	22.08.07	CHECKED	SSA
		APPROVED	DIVYA

विभाग
DEPT SWE

उम. टोल. माप की श्रेणी
UNTDL.DIMS. GR.

कोड
CODE 409

अनुपात
SCALE 1:1

भार
WEIGHT (K.G.)

उत्प्रे. ड्राईंग का संदर्भ
REF. TO ASSY. DRG.
35211001721

मद. सं. संख्या
ITEM NO.
002

ITEM 002 ADDED.

01

शीर्षक/TITLE
CATCH

उत्प्रे. ड्राईंग का संदर्भ
REF. TO ASSY. DRG.
3 521 10 01734

पृष्ठ सं./REV
पृष्ठों की संख्या/ NO. OF SH. 01

THE INFORMATION ON THIS DOCUMENT IS THE PROPERTY OF BHARAT HEAVY ELECTRICALS LIMITED IT MUST NOT BE USED DIRECTLY OR INDIRECTLY IN ANY WAY DETRIMENTAL TO THE INTEREST OF THE COMPANY

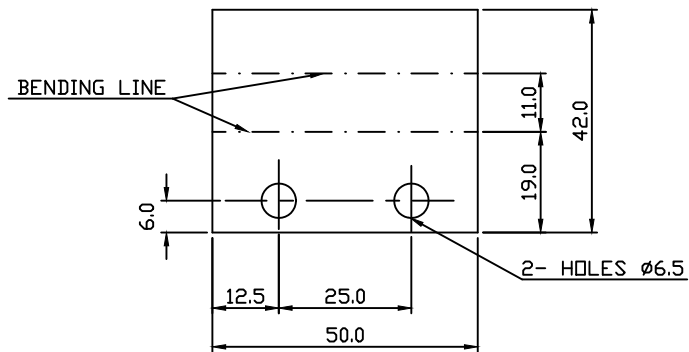

DEVELOPMENT OF ITEM 002

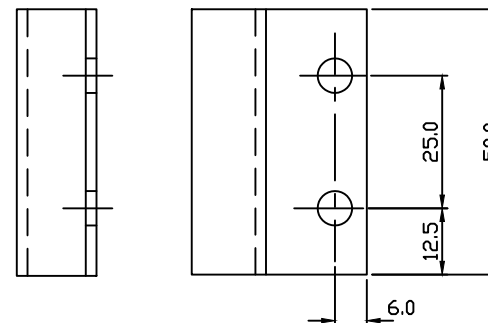
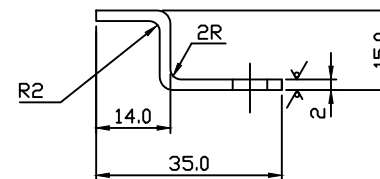

ITEM 002

65	REMARKS	75	78	79	25	27	29	DESCRIPTION	58	59	60	77	29	31	34	MATL. CODE	45	55	56	58	UNIT WT.	65	72	ZONE
									STD			DRAWING NO.	IT.ND.	VAR.	46	MATL. SPCN.	54	A	UNIT	68	QTY.	71	GS	
28 → CARD TYPE-3								28 → CARD TYPE-1					28 → CARD TYPE-2											

ADDITIONAL INFORMATION

STATUS OF DRAWING

DISTRIBUTION OF PRINTS

O.COPY-----1
 SWM-----3
 TCX-----1

उत्पाद का प्रकार या ग्राहक/परियोजना का नाम
 TYPE OF PRODUCT OR NAME OF CUSTOMER/PROJECT
VM-12 (BT2)



भारत हेवी इलेक्ट्रिकल्स लिमिटेड
 भोपाल
 BHARAT HEAVY ELECTRICALS LTD.
 BHOPAL

क्रमांक	नाम/NAME	हस्ता/ SIGN	दिनांक/ DATE	वे.र. की संख्या
DRN	SUS		23.08.07	NO. OF VAR
वे.चा. क्र. अनुमोदित	SSA		23.08.07	
APPD	DIVYA		23.08.07	

INVENTORY NO. SIGN. & DATE REF. DRG. NO.

REV.	DATE	ALTERED	REV.	DATE	ALTERED
		CHECKED			CHECKED
		APPROVED			APPROVED

विभाग DEPT	उत्प. टोल. माप की श्रेणी UNTOOL.DIMS. GR.	अनुपात SCALE	भार. कि.मा. WEIGHT (K.G.)	उत्प. इकाई का संदर्भ REF. TO ASSY. DRG.	मद. क्र. ITEM NO.	मद. संख्या NO. OF ITEM
SWE	409	1:1		35211001721		002
शीर्षक/TITLE				उत्प. क्र./ DRAWING NO.		पृष्ठ/REV
CATCH				पृष्ठ क्र./SHT. No. 02		पृष्ठों की संख्या/ NO. OF SHT. 02

THE INFORMATION ON THIS DOCUMENT IS THE PROPERTY OF BHARAT HEAVY ELECTRICALS LIMITED IT MUST NOT BE USED DIRECTLY OR INDIRECTLY IN ANY WAY DETRIMENTAL TO THE INTEREST OF THE COMPANY

DRG. NO. 35219005500

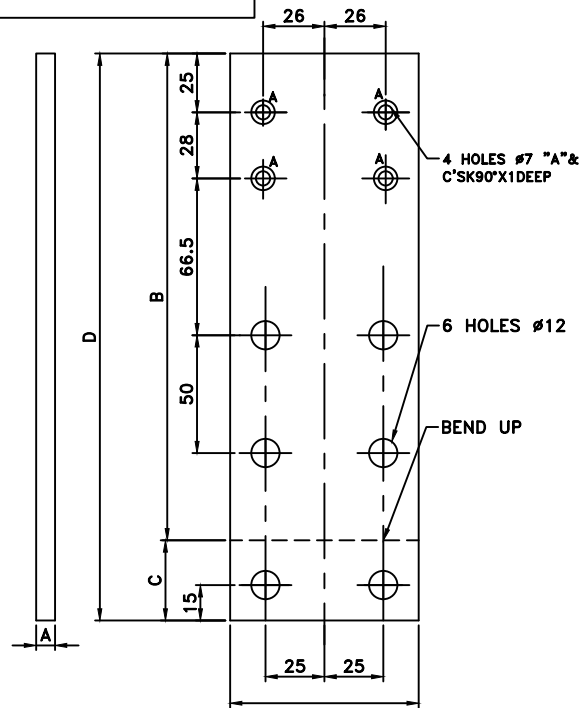

75 FOR ITEM 001 ONLY
100 FOR ITEM 002 & 003

DEVELOPMENT FOR ITEM -001 TO 003

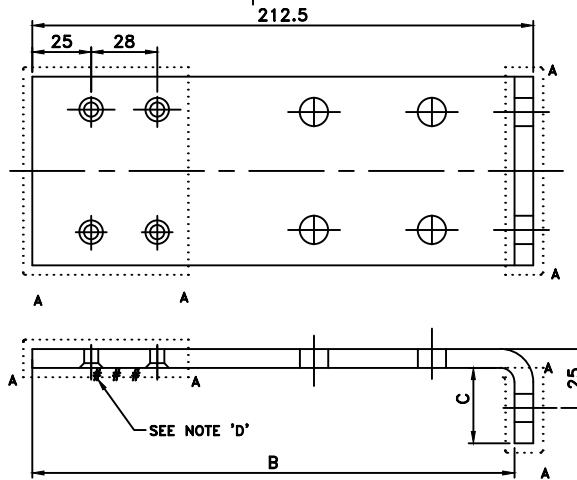

ITEM NO. 001 TO 003

ITEM NO.	A	B	C	D
001	6	206.5	34	240.5
002	8	204.5	32	236.5
003	10	202.5	30	232.5

IMPORTANT NOTES (CTQ)

A) SILVER PLATING ON AREA ALONG LENGTH MARKED "AA" SHALL BE DONE AS PER SG14610. SILVER PLATING THICKNESS SHALL BE MINIMUM 5 MICRON AND AREA SHALL BE 181.30 SQ. CM. FOR ITEM-001, 248.26 SQ. CM. FOR IT-002 & 259.73 SQ. CM. FOR IT.-003

B) 5% SAMPLE SHALL BE COMPULSORILY CHECKED FOR PLATING THICKNESS AFTER RECEIPT AT BHOPAL WORKS.

C) ADHESION AND ANTI-TARNISHING SHALL ALSO BE CHECKED.

D) SUPPLIER LOGO & PO NO. TO BE PUNCHED AT LOCATIONS MARKED ###.STICKER IS NOT ACCEPTABLE.

ITEM NO.	A	B	C	D	DESCRIPTION	STANDARD	DRAWING NO.	IT. NO.	MATL. CODE	UNIT WT.	QTY.	ZONE
003					10TK. X 100 X 232.5 LG. H. CPR. FLAT				BP1201905753	-		
									AA12005			
002					8TK. X 100 X 236.5 LG. H. CPR. FLAT				BP1201905745	1.136		
									AA12005			
001					6TK. X 75 X 240.5 LG. H. CPR. FLAT					-		
									AA12005			

28 → CARD TYPE-3

28 → CARD TYPE-1

28 → CARD TYPE-2

ADDITIONAL INFORMATION उत्पाद का प्रकार या ग्राहक/परियोजना का नाम TYPE OF PRODUCT OR NAME OF CUSTOMER/PROJECT VM12		STATUS OF DRAWING	
DISTRIBUTION OF PRINTS O.COPY-----1 SWM-----3 TCX-----1		भारत हेवी इलेक्ट्रिकल्स लिमिटेड भोपाल BHARAT HEAVY ELECTRICALS LTD. BHOPAL	
कमाटा DRN चेचा CKD अनुमोदित APPD	नाम/ NAME P.PARE	हस्ता/ SIGN sd/-	दिनांक/ DATE 09.11.01
चेचा CKD अनुमोदित APPD	नाम/ NAME K.S.M	हस्ता/ SIGN sd/-	दिनांक/ DATE 09.11.01
चेचा CKD अनुमोदित APPD	नाम/ NAME M.HUSSAIN	हस्ता/ SIGN sd/-	दिनांक/ DATE 09.11.01
विभाग DEPT SWE	जम. टोल. माप की त्रुटि UNTOL.DIMS. GR. कोड CODE 409	अनुपात SCALE 1:1	भार कि.मा. WEIGHT (K.G.)
REV. DATE 01 16.03.14 ALTERED CHECKED APPROVED AKN BPC HRP	विभाग DEPT SWE कोड CODE 409	अनुपात SCALE 1:1	भार कि.मा. WEIGHT (K.G.)
IMPORTANT NOTES (CTQ) UPDATED. (DCA NO.-32449)		उद्देश्य का संदर्भ REF. TO ASSY. DRG.	
शीर्षक/TITLE TOP FIXED CONTACT (BUSBAR CHAMBER)		मद्र. संख्या ITEM NO. 003	
पुन./REV 01		मद्र. संख्या ITEM NO. 003	
पुन./REV 01		मद्र. संख्या ITEM NO. 003	

THE INFORMATION ON THIS DOCUMENT IS THE PROPERTY OF BHARAT HEAVY ELECTRICALS LIMITED. IT MUST NOT BE USED DIRECTLY OR INDIRECTLY IN ANY WAY DETRIMENTAL TO THE INTEREST OF THE COMPANY.

REV.	DATE	ALTERED	REV.	DATE	ALTERED	ADDITIONAL INFORMATION
		CHECKED	01		CHECKED	STATUS OF DRAWING
DRG.REDRAWN. VIEW ADDED FOR EACH ITEMS (DCA.....)						DISTRIBUTION OF PRINTS □/C-1 SWM-3 TCX-1

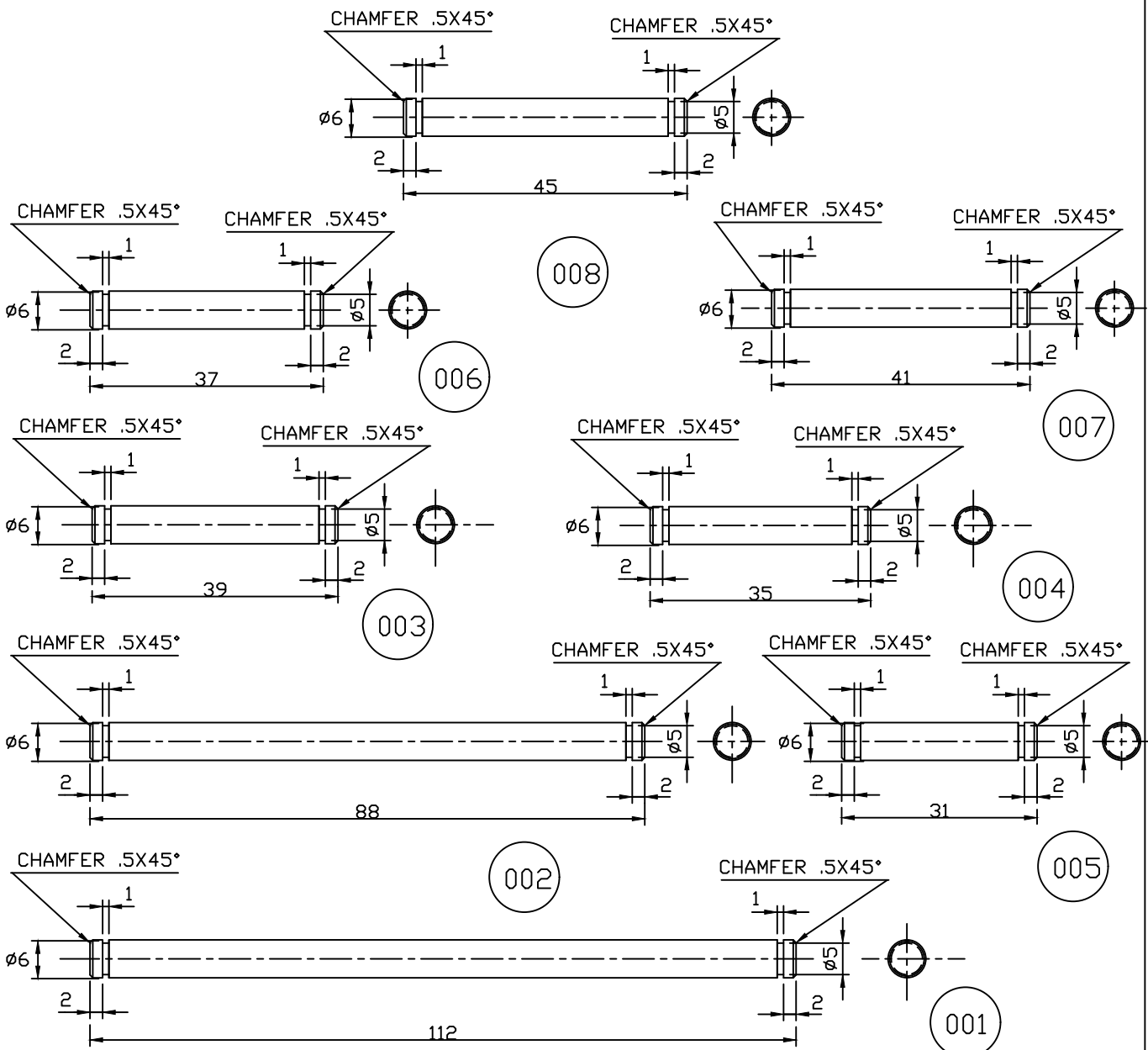

FOR B.O.M. REF SHEET NO. 02

INVENTORY No. 45211001727-R01-S01
REF. DRG. No.
SIGN & DATE

REMARKS	ITEM NO.	DESCRIPTION	STD.	MATL. CODE	A	UNITS	UNIT WT.
				MATL. SPECN	C		QTY.

 BHATAT HEAVY ELECTRICALS LIMITED BHOPAL	DRN	G.PRASAD	SIGN.	[Signature]	DATE	07.04.01	NO.OF VAR	
	CHD	S.S.A.	SIGN.	[Signature]	DATE	29.05.01	-	
	APPD	D.BHATT	SIGN.	[Signature]	DATE	29.05.01	-	
DEPT. SWE	UN. TOL.DIM.GR.	SCALE	WEIGHT (Kg.)	REF. TO ASSY. DRG.	ITEM MD. 010 & 011	NO.OF ITEMS	NO.OF REV.	
CODE 409		1:1		35211001721		008	01	
TITLE				DRAWING No. 4 521 1 00 1727			REV.	
GROOVE PIN				SHEET NO. 01			NO.OF SHEETS 02	

REV.	DATE	ALTERED	REV.	DATE	ALTERED	ADDITIONAL INFORMATION
		CHECKED		01		
			DRG.REDRAWN. VIEW ADDED FOR EACH ITEMS (DCA.NO.22581)			STATUS OF DRAWING
						DISTRIBUTION OF PRINTS □/C-1 SWM-3 TCX-1





THE INFORMATION ON THIS DOCUMENT IS THE PROPERTY OF BHARAT HEAVY ELECTRICALS LIMITED. IT MUST NOT BE USED DIRECTLY OR INDIRECTLY IN ANY WAY DETRIMENTAL TO THE INTEREST OF THE COMPANY.

UNSPECIFIED TOLERANCES SHALL BE :-
 FOR MACHINING MEDIUM AA0230208.
 FOR SHEARING OF SHEETS AS PER AA0230409.
FINISH :-
 ZINC PLATE & PASSIVATE TO AA0673603 AND
 AA0673604 (0.013 TK. MIN.)

45211001727-R01-S01
REF. DRG. No.

REMARKS	ITEM NO.	DESCRIPTION	STD.	MATL. CODE	A - C	UNITS	UNIT WT.
				MATL. SPECN			QTY.
	008	6 DIAX45 LG BRT STEEL BARS		BP 1010272020 BP 10172			0.009 001
	007	6 DIAX41 LG BRT STEEL BARS		BP 1010272020 BP 10172			0.008 001
	006	6 DIAX37 LG BRT STEEL BARS		BP 1010272020 BP 10172			0.008 001
	005	6 DIAX31 LG BRT STEEL BARS		BP 1010272020 BP 10172			0.006 001
	004	6 DIAX35 LG BRT STEEL BARS		BP 1010272020 BP 10172			0.007 001
	003	6 DIAX39 LG BRT STEEL BARS		BP 1010272020 BP 10172			0.008 001
	002	6 DIAX88 LG BRT STEEL BARS		BP 1010272020 BP 10172			0.018 001
	001	6 DIAX112 LG BRT STEEL BARS		BP 1010272020 BP 10172			0.023 001

SIGN & DATE
INVENTORY No.

	BHARAT HEAVY ELECTRICALS LIMITED BHOPAL		DRN	G.PRASAD	SIGN.		DATE	07.04.01	NO.OF VAR	
			CHD	S.S.A.	SIGN.		DATE	29.05.01		
			APPD	D.BHATT	SIGN.		DATE	29.05.01		
DEPT. SWE	UN. TOL.DIM.GR.	SCALE	WEIGHT (Kg.)	REF. TO ASSY. DRG.	ITEM NO. & 011	NO.OF ITEMS				
CODE 409		1:1		35211001721	010 & 011	008				
TITLE				DRAWING No.				REV.		
GROOVE PIN				4 521 1 00 1727				01		
				SHEET NO. 02				NO.OF SHEETS 02		

THE INFORMATION ON THIS DOCUMENT IS THE PROPERTY OF BHARAT HEAVY ELECTRICALS LIMITED. IT MUST NOT BE USED DIRECTLY OR INDIRECTLY IN ANY WAY DETRIMENTAL TO THE INTEREST OF THE COMPANY.

REV.	DATE	ALTERED	MKN	REV.	DATE	ALTERED	ADDITIONAL INFORMATION
01	20.09.13	CHECKED	AKHIL			CHECKED	
DIM. 20, 8.2 & 0.5X45° WERE DIM. 15, 5.7 & 0.3X45° RESPECTIVELY. (DCA. NO.32119)							STATUS OF DRAWING
							DISTRIBUTION OF PRINTS □/C-1 SWM-3 TCX-1

UNSPECIFIED TOLERANCES SHALL BE :-
FOR MACHINING MEDIUM AA0230208,
FOR SHEARING OF SHEETS AS PER AA0230409.

FINISH :-
ZINC PLATE & PASSIVATE TO AA0673603 AND
AA0673604 (0.013 TK. MIN.)

OLD DRG.-45964011101

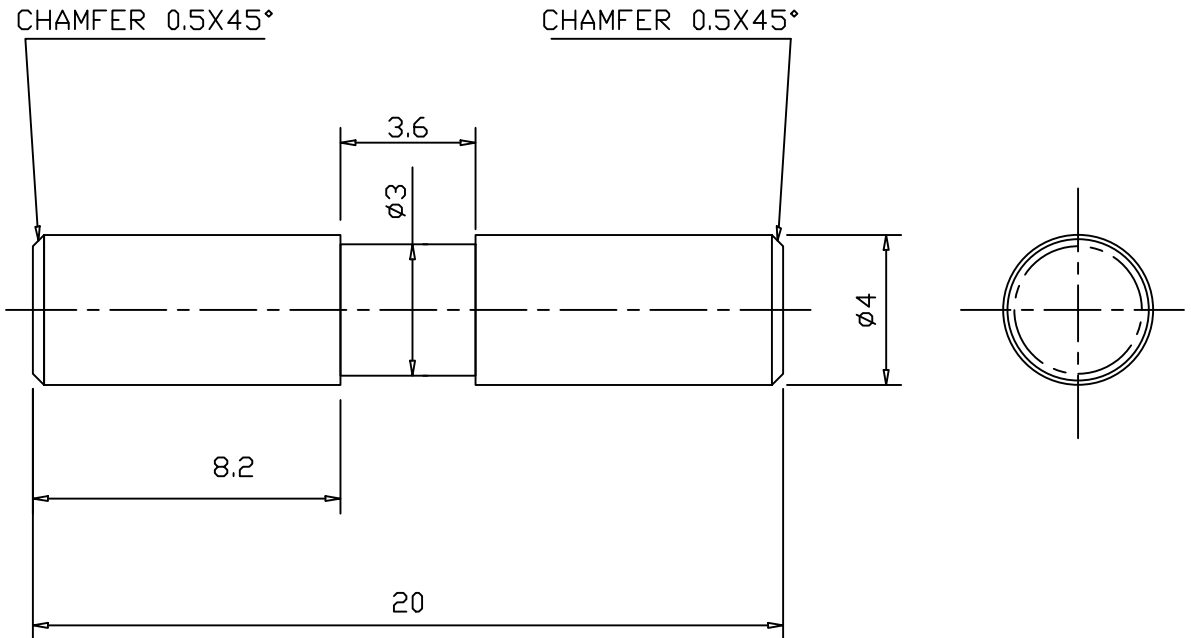

45211001728-R01-S01
REF. DRG. No.

REMARKS	ITEM NO.	DESCRIPTION	STD.	AA1010212010	A - C	UNITS	0.002
				AA10112			001
				MATL. CODE			UNIT WT.
				MATL. SPECN			QTY.

SIGN & DATE
INVENTORY No.

<p>BHATAT HEAVY ELECTRICALS LIMITED BHOPAL</p>		DRN	G.PRASAD	SIGN.		DATE	07.04.01	NO. OF VAR
		CHD	S.S.A.	SIGN.		DATE	29.05.01	
		APPD	D.BHATT	SIGN.		DATE	21.12.98	
DEPT. SWE	UN. TOL. DIM. GR.		SCALE	WEIGHT (Kg.)	REF. TO ASSY. DRG.		ITEM NO.	NO. OF ITEMS
CODE 409			10:1		35211001721	019	001	
TITLE					DRAWING No.			REV.
PIN					4 521 10 01728			
					SHEET NO. 01		NO. OF SHEETS 01	

THE INFORMATION ON THIS DOCUMENT IS THE PROPERTY OF BHARAT HEAVY ELECTRICALS LIMITED. IT MUST NOT BE USED DIRECTLY OR INDIRECTLY IN ANY WAY DETRIMENTAL TO THE INTEREST OF THE COMPANY.

REV.	DATE	ALTERED	REV.	DATE	ALTERED	ADDITIONAL INFORMATION
		CHECKED			CHECKED	
						STATUS OF DRAWING
						DISTRIBUTION OF PRINTS

□/C-1 SWM-3
TCX-1

UNSPECIFIED TOLERANCES SHALL BE :-
 FOR MACHINING MEDIUM AA0230208.
 FOR SHEARING OF SHEETS AS PER AA0230409.
FINISH :-
 ZINC PLATE & PASSIVATE TO AA0673603 AND
 AA0673604 (0.013 TK. MIN.)
 OLD DRG.-35964011104

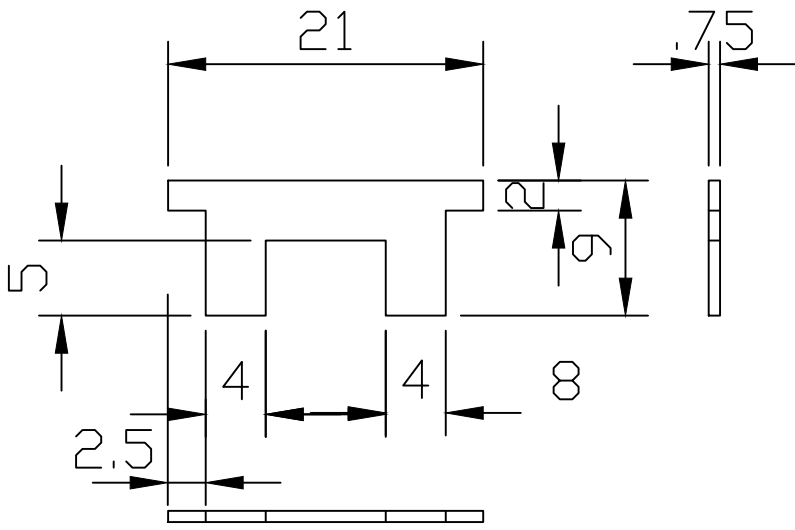

45211001729-R00-S01

REF. DRG. No.

SIGN & DATE

INVENTORY No.

REMARKS	ITEM NO.	DESCRIPTION	STD.	MATL. CODE	A - C	UNITS	UNIT WT.
	001	0.75TK.x9x21 LG. CR.C.S.SHEET		BP 1011715988			0.001
				AA 10115			001
				MATL. SPECN			QTY.



BHARAT HEAVY ELECTRICALS LIMITED
BHPAL

DRN	NAME	SIGN.	DATE	NO. OF VAR
CHD	G.PRASAD		07.04.01	
APPD	S.S.A.		29.05.01	
	D.BHATT		29.05.01	

DEPT. SWE	UN. TOL.DIM.GR.	SCALE	WEIGHT (Kg.)	REF. TO ASSY. DRG.	ITEM NO.	NO. OF ITEMS
CODE 409		2:1		35211001721	007	001
TITLE				DRAWING No.	REV.	
COTTER PIN				4 521 1001729	00	
				SHEET NO. 01	NO. OF SHEETS	01

DRG. NO. 25219002523

WT. OF CPR. FOR :-

- VAR-00 - 1.978 KG.
- VAR-01 - 1.602 KG.
- VAR-02 - 3.046 KG.
- VAR-03 - 3.046 KG.
- VAR-04 - 1.978 KG.

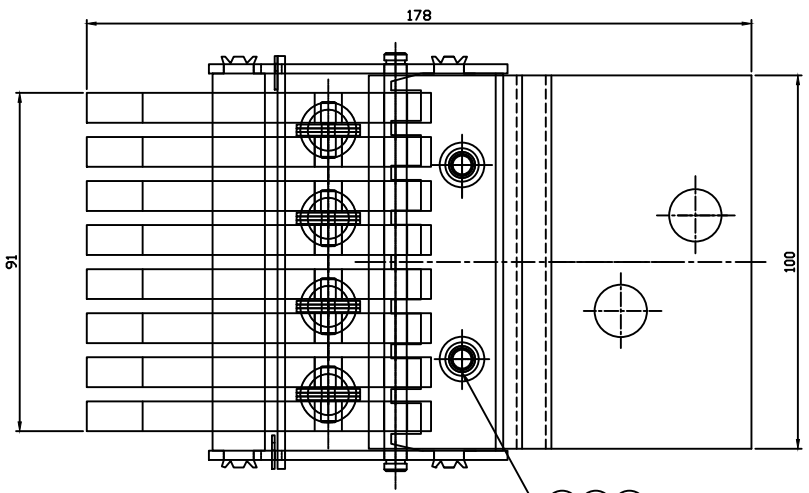
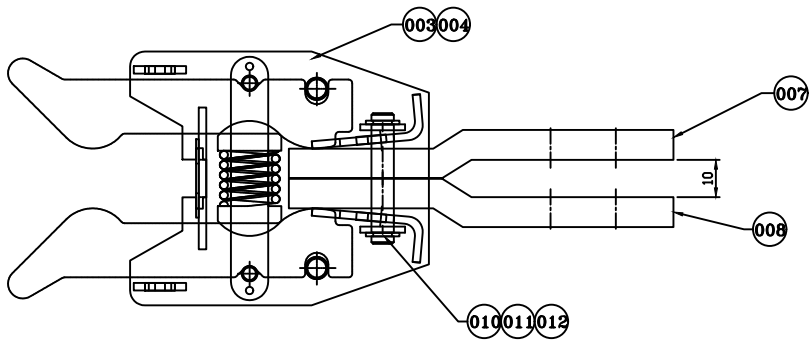

VAR. 02 & 03
(2NOS.-8TK. x 100 WIDE CONNECTOR)

VAR 04	VAR 03	VAR 02	VAR 01	VAR00	REMARKS	VAR NO.	ITEM NO.	DESCRIPTION	DRAWING NO.	UNIT	QTY.	UNIT WT.	ZONE
						013		PLUG IN CONTACT ASSY.	35211001721	07			
						012		CIRCLIP C5-ST				AA7167006	
						011		WASHER MCD 6.4-ST				AA7161001016	
						010		GROOVE PIN	45211001727	004			
						009		GROOVE PIN	45211001727	005			
						008		BOTTOM FIXED CONTACT	35219006505	004		0.771	
						007		BOTTOM FIXED CONTACT	35219006505	003		0.771	
						006		BOTTOM FIXED CONTACT	35219006505	002		0.425	
						005		BOTTOM FIXED CONTACT	35219006505	001		0.425	
						004		PLUG IN CONTACT ASSY.	35211001721	02			
						003		PLUG IN CONTACT ASSY.	35211001721	01			
						002		PLUG IN CONTACT ASSY.	35211001721	03			
						001		PLUG IN CONTACT ASSY.	35211001721	04			

28 - CARD TYPE-3

28 - CARD TYPE-1

28 - CARD TYPE-2

THE INFORMATION ON THIS DOCUMENT IS THE PROPERTY OF BHARAT HEAVY ELECTRICALS LIMITED. IT MUST NOT BE USED DIRECTLY OR INDIRECTLY IN ANY WAY DETRIMENTAL TO THE INTEREST OF THE COMPANY.

SIGN AND DATE

INVENTORY NO.

ADDITIONAL INFORMATION STATUS OF DRAWING B DISTRIBUTION OF PRINTS O/C - 1 TX - 1 SWM - 3		उत्पाद का प्रकार वा ग्राहक/परियोजना का नाम TYPE OF PRODUCT OR NAME OF CUSTOMER/PROJECT VM-12 (BT-II)	
डिप्टी सुप. उन्. टन. नाय की सेवा DEPT. SWE. UNTDL. DIHS. GR. कोड 409 AA 0230208		भारत हेवी इलेक्ट्रिकल्स लिमिटेड भोपाल BHARAT HEAVY ELECTRICALS LTD. BHOPAL	
नाम/TITLE BOTTOM CONTACT ASSY.		नाम/NAME S.U.S. S.S.A. J.S.P.	
ड्राइंग का नंबर 25219002523		ड्राइंग का नंबर 29.12.01	
प्रक. शीट. नं. 02		प्रक. शीट. नं. 05	

REV.	DATE	ALTERED	SKG	REV.	DATE	ALTERED	P.PARE	REV.	DATE	ALTERED	SUS	REV.	DATE	ALTERED	SUS	REV.	DATE	ALTERED	SUS
05	26.10.21	CHECKED AT APPROVED	AD	04	09.08.10	CHECKED APPROVED	K.S.MANI MAK	03	17.08.07	CHECKED APPROVED	SSA ANITA	02	16.3.06	CHECKED APPROVED	SSA RM	01	7.3.06	CHECKED APPROVED	SSA RM
VAR 04 & ITEM 015 ADDED. (DCA 37336)				WT. OF CPR. FOR VAR. 00 TO 03 ADDED (DCA NO. 29915)				DRG. CORRECTED. & REDRAWN (DCA NO. 26950)				VAR. DESCRIPTION MODIFIED (DCA NO.25316)				AMP. RATING REMOVED (DCA NO.-25291)			

THE INFORMATION ON THIS DOCUMENT IS THE PROPERTY OF BHARAT HEAVY ELECTRICALS LIMITED. IT MUST NOT BE USED DIRECTLY OR INDIRECTLY IN ANY WAY DETRIMENTAL TO THE INTEREST OF THE COMPANY.

DRG NO 3 521 10 01 721

VAR. 08	VAR. 07	VAR. 06	VAR. 05	VAR. 04	VAR. 03	VAR. 02	VAR. 01	VAR 00	REMARKS	VAR NO.	ITEM NO.	DESCRIPTION	PLS	DRAWING NO.	IT.NO. VAR	MATERIAL CODE MATL. SPCN. C	A	UNIT	UNIT WT. QTY
-	-	-	-	-	-	012	012	-			014	SPRING PULL ROD		35211001731	002				0.004
-	-	-	-	-	-	-	-	012			013	SPRING PULL ROD		35211001731	001				0.004
004	004	004	004	004	004	004	004	004			012	CIRCLIP C5-ST				AA 7167006			0.001
002	002	-	002	002	002	-	-	-			011	GROOVE PIN		45211001727	002				0.018
-	-	002	-	-	-	002	002	002			010	GROOVE PIN		45211001727	001				0.023
-	-	-	004	012	008	016	-	-			009	JAW CONTACT		35211001727	002				0.085
004	012	016	-	-	-	-	016	016			008	JAW CONTACT		35211001727	001				0.085
002	002	002	002	002	002	002	002	002			007	COTTER PIN		45211001729	001				0.001
001	001	-	001	001	001	-	-	-			006	SHUTTER		35211001724	003				0.036
-	-	-	-	-	-	001	001	-			005	SHUTTER		35211001724	002				0.052
-	-	-	-	-	-	-	-	001			004	SHUTTER		35211001724	001				0.057
001	001	-	001	001	001	-	-	-			003	JAW BODY		35211001723	02				0.276
-	-	-	-	-	-	001	001	-			002	JAW BODY		35211001723	01				0.320
-	-	-	-	-	-	-	-	001			001	JAW BODY		35211001723	00				0.330
VAR. 08	VAR. 07	VAR. 06	VAR. 05	VAR. 04	VAR. 03	VAR. 02	VAR. 01	VAR 00	REMARKS	VAR NO.	ITEM NO.	DESCRIPTION	PLS	DRAWING NO.	IT.NO. VAR	MATERIAL CODE MATL. SPCN. C	A	UNIT	UNIT WT. QTY

35211001721-R04-S07 REF.DRG.NO.

INVENTORY NO. SIGN. & DATE

REV	DATE	ALT.	AT	REV	DATE	ALT.	AT	ADDITIONAL INFORMATION				TYPE OF PRODUCT OR NAME OF CUST/PROJ									
06	05.01.22	CKD.	AT	05	03.12.20	CKD.	AT	STATUS OF DRAWING				VM-12 (BT-2)									
		APPD.	AD			APPD.	AD	DISTRIBUTION OF PRINTS													
		VAR08 ADDED				VAR07 ADDED		कार्यालय प्रति ----- 1 दस डब्ल्यू. दम. - 3 टी. सी. दवेस. ----- 1				 BHARAT HEAVY ELECTRICALS LIMITED BHOPAL		DRN	NAME	SIGN	DATE	NO. OF VAR			
		(DCA NO. 37429)				(DCA NO. 36965)						CKD	SUS		22.08.07	09					
												APPD	D.BHATT		22.08.07						
04	11.08.10	CKD.	P.PARE	03	22.08.07	CKD.	SUS	02	17.08.07	DRN	SUS	DEPT	UN. TOL.DIMGR.	SCALE	WEIGHT (KG.)	REF TO ASSY		ITEM MD.	NO. OF ITEMS		
		APPD.	MANI			APPD.	SSA			CKD	SSA	CODE				DRG NO					
		APPD.	DIVYA			APPD.	DIVYA			APPD	ANITA	409				3 521 10 01721			06		
		-FOR IT-011 QTY. CHANGED TO 002NDS. FROM 003 NDS. -FOR IT-005 QTY. NULLIFIED FOR VAR.04 -WEIGHT OF COPPER MENTIONED FOR VAR.00,01,02,03,04 IN SHT#08 (DCA NO. 29558)				VAR. 06 & SHT. 08 ADDED. BDM REARRANGED. (DCA NO. 26965)				DRG. CORRECTED. (DCA NO. 26952)				TITLE		PLUG IN CONTACT ASSY.		SHT.NO.	07	NO. OF SHT.	08

FIRST ANGLE PROJECTION

ALL DIMENSIONS ARE IN mm.

DRG NO 3 521 10 01 721

THE INFORMATION ON THIS DOCUMENT IS THE PROPERTY OF BHARAT HEAVY ELECTRICALS LIMITED. IT MUST NOT BE USED DIRECTLY OR INDIRECTLY IN ANY WAY DETRIMENTAL TO THE INTEREST OF THE COMPANY.

35211001721-R05-S01

REF.DRG.NO.

INVENTORY NO.

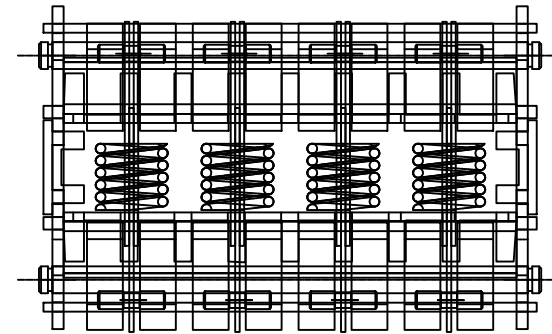
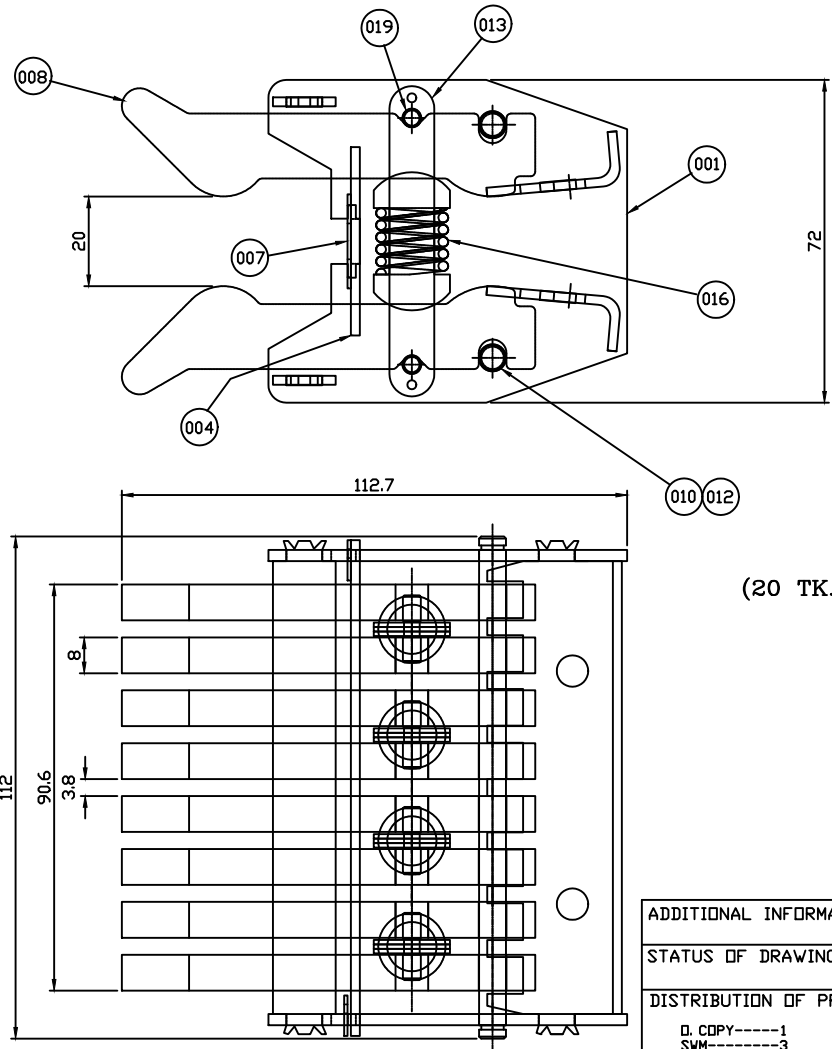

VAR-00
(20 TK. x 100 WIDE CONNECTOR - 3150 Amps.)

ADDITIONAL INFORMATION		TYPE OF PRODUCT OR NAME OF CUST/PROJ		VM-12 (BT-II)						
STATUS OF DRAWING		DISTRIBUTION OF PRINTS		BHARAT HEAVY ELECTRICALS LIMITED BHOPAL	DRN	NAME	SIGN	DATE	NO. OF VAR	
D. COPY-----1 SWM-----3 TCX-----1		REV 03 22.08.07			CKD	SUS		22.08.07	09	
		REV 04 11.08.10			APPD	D.BHATT		22.08.07		
REV 06	DATE 05.01.22	ALT. CKD.	AT APPD.	DEPT SWE	UN. TOL.DIMGR.	SCALE	WEIGHT (KG.)	REF TO ASSY	ITEM NO.	NO. OF ITEMS
06	05.01.22		AD	409		1:1				019
VAR08 ADDED		- VAR07 ADDED.		TITLE		DRG NO		REV.		
(DCA NO. 37429)		(DCA NO. 36965)		PLUG IN CONTACT ASSY.		3 521 10 01721		06		
		-FDR IT-011 QTY. CHANGED TO 002NOS. FROM 003 NOS. -FDR IT-005 QTY. NULLIFIED FOR VAR.04 -WEIGHT OF COPPER MENTIONED FOR VAR.00,01,02,03,04 IN SHT#08 (DCA NO. 29558)		VAR. 06 & SHT. 08 ADDED. BDM REARRANGED.		SHT.NO.		01		NO. OF SHT.
		(DCA NO. 26965)		(DCA NO. 26965)						08

FIRST ANGLE PROJECTION

ALL DIMENSIONS ARE IN mm.

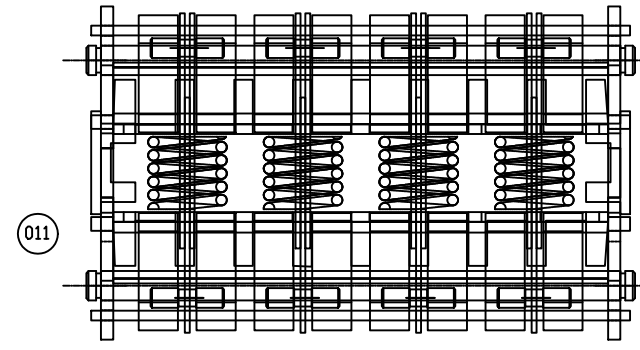
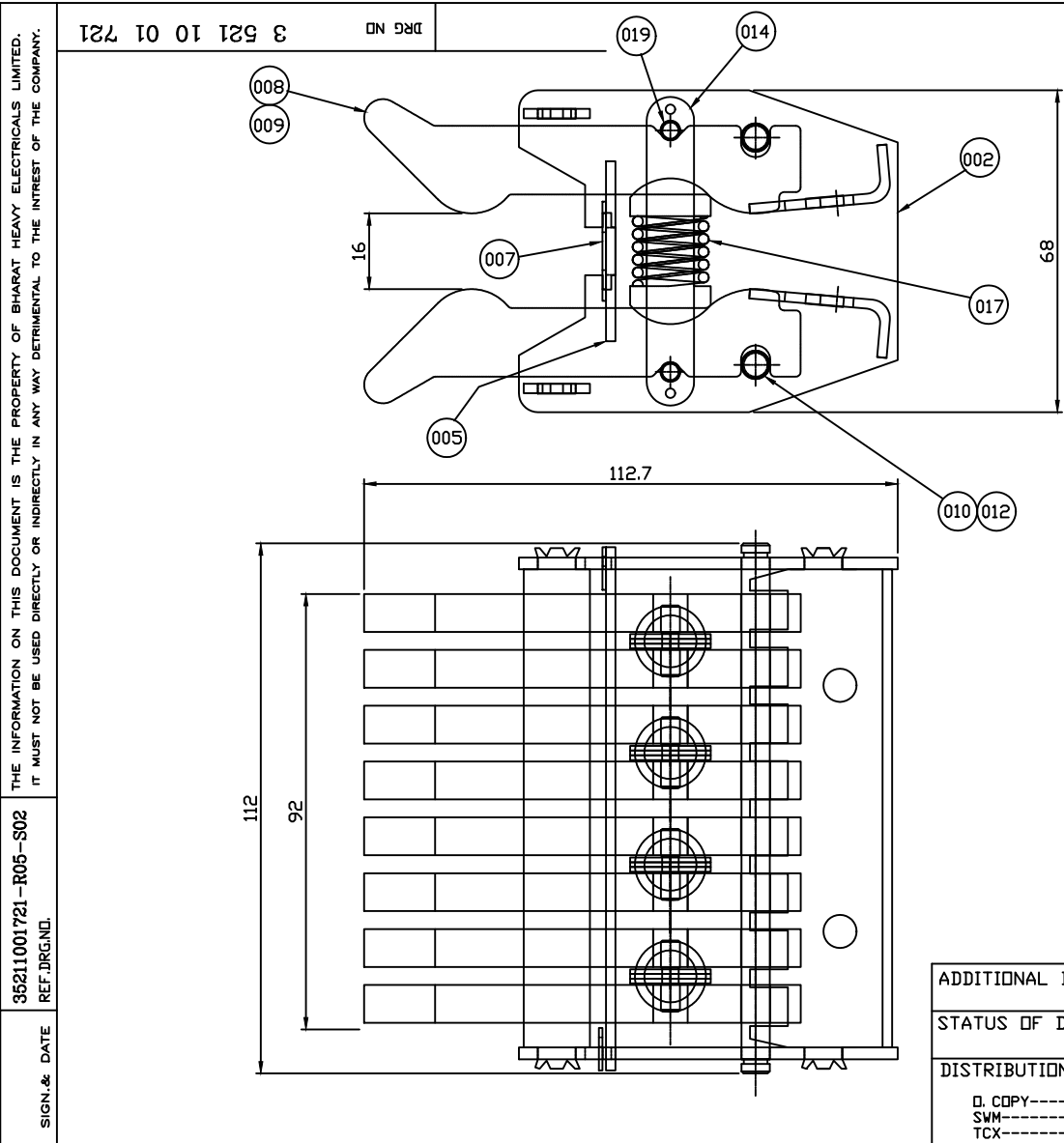



VAR-01 & 02
 (VAR.01-16 TK. x 100 WIDE CONNECTOR -2500 Amps.)
 (VAR.02-16 TK. x 100 WIDE CONNECTOR -2000 Amps.)

35211001721-R05-S02
 REF.DRG.NO.
 SIGN. & DATE
 INVENTORY NO.

3 521 10 01 721
 DRG NO

REV	DATE	ALT.	AT	REV	DATE	ALT.	AT	REV	DATE	ALT.	P.PARE
06	05.01.22	CKD.	AT	05	03.12.20	CKD.	AT	04	11.08.10	CKD.	MANI
		APPD.	AD			APPD.	AD			APPD.	DIVYA
	VAR08 ADDED				-VAR07 ADDED.				-FDR IT-011 QTY. CHANGED TO 002NDS. FROM 003 NDS.		
	(DCA NO. 37429)				(DCA NO. 36965)				-FDR IT-005 QTY. NULLIFIED FOR VAR.04		
									-WEIGHT OF COPPER MENTIONED FOR VAR.00,01,02,03,04 IN SHT#08		
									(DCA NO. 29558)		

ADDITIONAL INFORMATION				TYPE OF PRODUCT OR NAME OF CUST/PROJ											
STATUS OF DRAWING				VM-12 (BT-2)											
DISTRIBUTION OF PRINTS				 BHARAT HEAVY ELECTRICALS LIMITED BHOPAL				DRN SUS 22.08.07		NAME SIGN DATE 22.08.07		NO. OF VAR 09			
□ COPY-----1 SWM-----3 TCX-----1				DEPT SWE CODE 409		UN. TOL.DIM.GR.		 SCALE 1:1		WEIGHT (KG.)		REF TO ASSY ITEM MD.		NO.OF ITEMS 019	
REV 03 22.08.07 ALT. SUS CKD. SSA APPD. DIVYA				VAR. 06 & SHT. 08 ADDED. BDM REARRANGED. (DCA NO. 26965)				TITLE PLUG IN CONTACT ASSY.				DRG NO 3 521 10 01721		REV. 06	
				SHT.ND.		02		NO. OF SHT.		08					

FIRST ANGLE PROJECTION

ALL DIMENSIONS ARE IN mm.

THE INFORMATION ON THIS DOCUMENT IS THE PROPERTY OF BHARAT HEAVY ELECTRICALS LIMITED. IT MUST NOT BE USED DIRECTLY OR INDIRECTLY IN ANY WAY DETRIMENTAL TO THE INTEREST OF THE COMPANY.

35211001721-R05-S04
REF.DRG.NO.

SIGN. & DATE

INVENTORY NO.

DRG NO 3 521 10 01 721

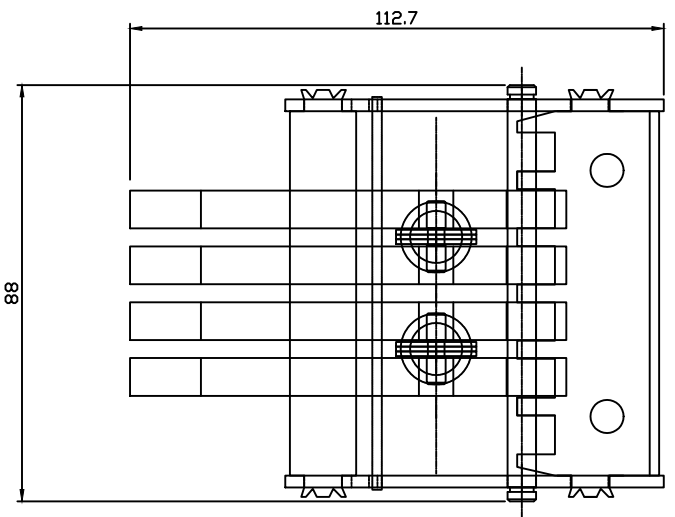
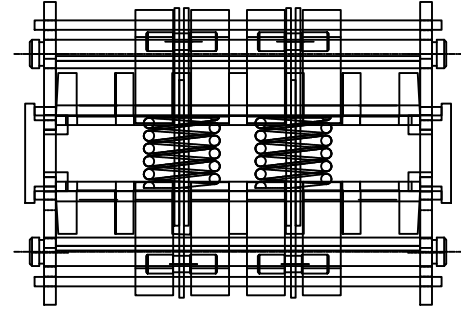
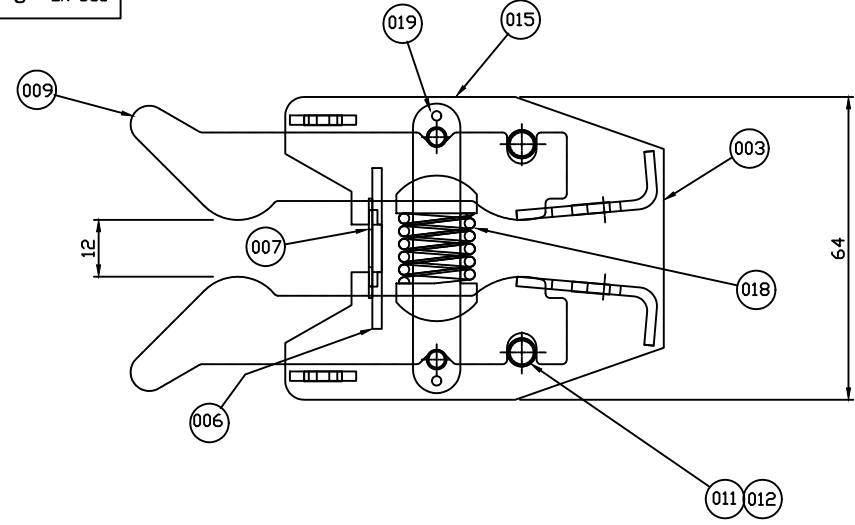

VAR-03
(12 TK. x 75 WIDE CONNECTOR - 630 Amps.)

REV	DATE	ALT. CKD.	AT	APPD.	REV	DATE	ALT. CKD.	AT	APPD.	REV	DATE	ALT. CKD.	AT	APPD.	P.PARE
06	05.01.22				05	03.12.20				04	11.08.10				
VAR08 ADDED (DCA NO. 37429)					VAR07 ADDED. (DCA NO. 36965)					-FOR IT-011 QTY. CHANGED TO 002NDS. FROM 003 NDS. -FOR IT-005 QTY. NULLIFIED FOR VAR.04 -WEIGHT OF COPPER MENTIONED FOR VAR.00,01,02,03,04 IN SHT#08 (DCA NO. 29558)					

ADDITIONAL INFORMATION				TYPE OF PRODUCT OR NAME OF CUST/PROJ VM-12 (BT-2)															
STATUS OF DRAWING				DISTRIBUTION OF PRINTS															
D. COPY-----1 SWM-----3 TCX-----1				 BHARAT HEAVY ELECTRICALS LIMITED BHOPAL				DRN		NAME		SIGN		DATE		NO. OF VAR			
				APPD		D.BHATT		SUS				22.08.07		09					
				SWE		UN. TOL.DIM.GR.		SCALE		WEIGHT (KG.)		REF TO ASSY		ITEM NO.					
				409				1:1											
				TITLE PLUG IN CONTACT ASSY.								DRG NO 3 521 10 01721							
												SHT.NO.		04		NO. OF SHT.		08	
																		REV. 06	

FIRST ANGLE PROJECTION

ALL DIMENSIONS ARE IN mm.

35211001721-R05-S05 REF.DRG.ND.

SIGN & DATE

INVENTORY NO.

DRG NO 3 521 10 01 721

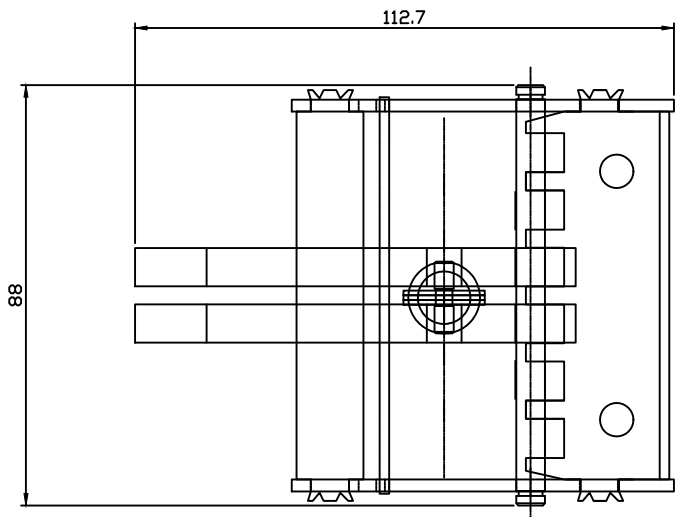
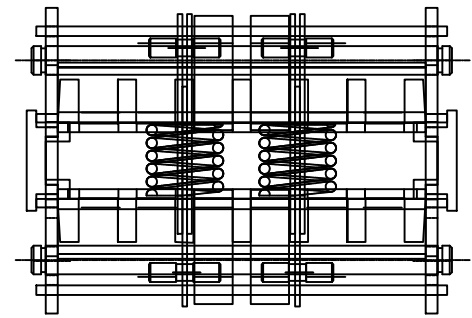
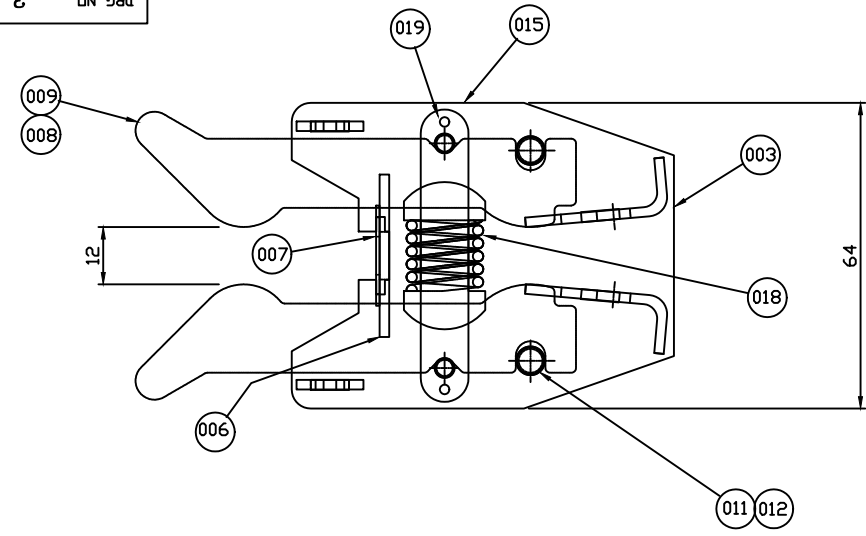

VAR-05 & 08
(12 TK. x 75 WIDE CONNECTOR - 400 Amps.)

ADDITIONAL INFORMATION				TYPE OF PRODUCT OR NAME OF CUST/PROJ				VM-12 (BT-2)					
STATUS OF DRAWING				DISTRIBUTION OF PRINTS				Bharat Heavy Electricals Limited Bhopal					
D. COPY-----1 SWM-----3 TCX-----1				DEPT SWE CODE 409				UN. TOL.DIM.GR.		SCALE 1:1		WEIGHT (KG.)	
				TITLE				REF TO ASSY		ITEM NO.		NO. OF ITEMS	
				PLUG IN CONTACT ASSY.				DRG NO		3 521 10 01721		REV.	
								SHT.NO.		05		NO. OF SHT.	
												08	

REV	DATE	ALT. CKD.	AT	REV	DATE	ALT. CKD.	AT	REV	DATE	ALT. CKD.	P.PARE	REV	DATE	ALT. CKD.	SUS
06	05.01.22	APPD.	AD	05	03.12.20	APPD.	AD	04	11.08.10	APPD.	MANI DIVYA	03	22.08.07	APPD.	SSA DIVYA
VAR08 ADDED (DCA NO. 37429)				- VAR07 ADDED. (DCA NO. 36965)				-FOR IT-01 QTY. CHANGED TO 002NDS. FROM 003 NDS. -FOR IT-005 QTY. NULLIFIED FOR VAR.04 -WEIGHT OF COPPER MENTIONED FOR VAR.00,01,02,03,04 IN SHT#08 (DCA NO. 29558)				VAR. 06 & SHT. 08 ADDED. BOM REARRANGED. (DCA NO. 26965)			

FIRST ANGLE PROJECTION

ALL DIMENSIONS ARE IN mm.

THE INFORMATION ON THIS DOCUMENT IS THE PROPERTY OF BHARAT HEAVY ELECTRICALS LIMITED. IT MUST NOT BE USED DIRECTLY OR INDIRECTLY IN ANY WAY DETRIMENTAL TO THE INTEREST OF THE COMPANY.

35211001721-R05-S06
REF.DRG.ND.

SIGN. & DATE

INVENTORY NO.

DRG NO 3 521 10 01 721

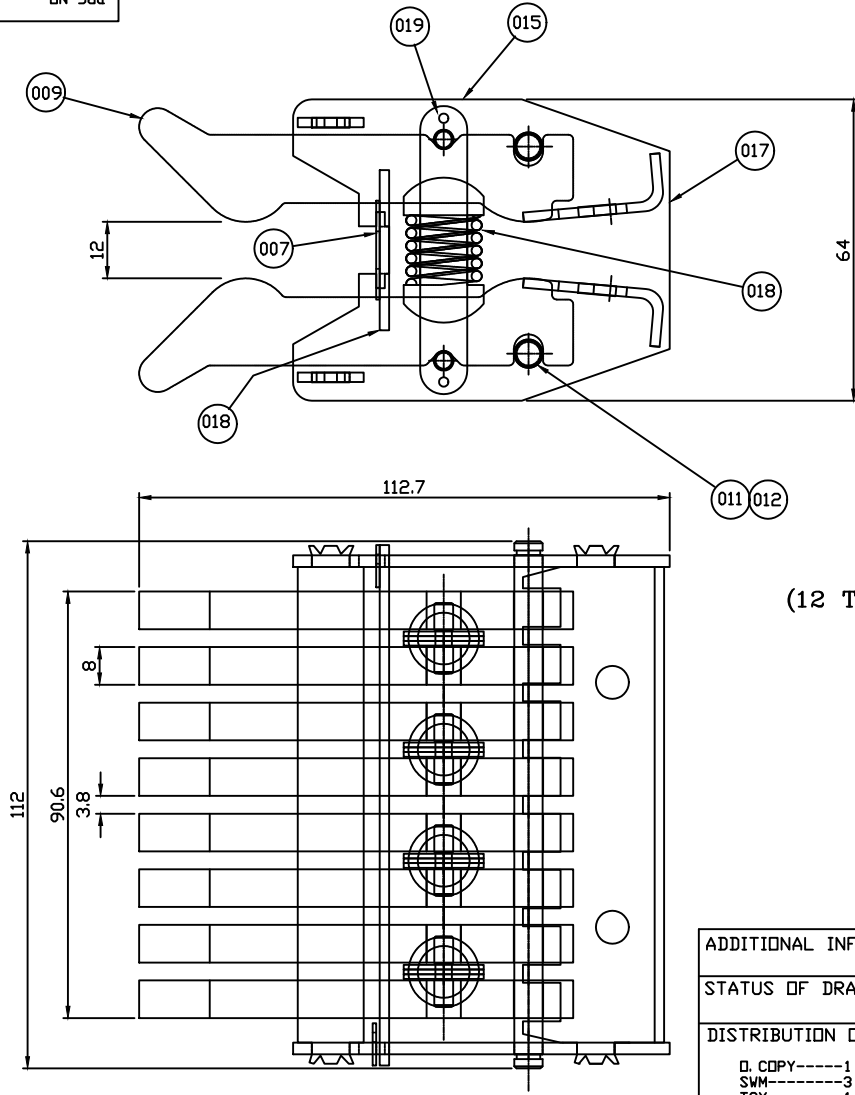

VAR-06
(12 TK x 100 WIDE CONNECTOR -2500 Amps.)

ADDITIONAL INFORMATION				TYPE OF PRODUCT OR NAME OF CUST/PROJ VM-12 (BT-2)																			
STATUS OF DRAWING				DISTRIBUTION OF PRINTS						 BHARAT HEAVY ELECTRICALS LIMITED BHOPAL			DRN	NAME	SIGN	DATE	NO. OF VAR						
D. COPY-----1				D. COPY-----1						SWE			CKD	SSA		22.08.07	09						
SWM-----3				SWM-----3						APPD			APPD	D.BHATT		22.08.07							
TCX-----1				TCX-----1						DEPT			REF TO ASSY			ITEM NO.	NO. OF ITEMS						
REV 06				REV 05				REV 04				REV 03				UN. TOL. DIM. GR.		SCALE		WEIGHT (KG.)		REV.	
DATE		ALT. AT		DATE		ALT. AT		DATE		ALT. AT		DATE		ALT. SUS		1:1				DRG NO			
05.01.22		CKD. AT		03.12.20		CKD. AT		11.08.10		CKD. MANI		22.08.07		CKD. SSA						3 521 10 01721			
		APPD. AD				APPD. AD				APPD. DIVYA				APPD. DIVYA						SHT. NO. 06			
VAR08 ADDED				-VAR07 ADDED.				-FOR IT-011 QTY. CHANGED TO 002NDS. FROM 003 NDS.				VAR. 06 & SHT. 08 ADDED. BOM REARRANGED.										NO. OF SHT. 08	
(DCA NO. 37429)				(DCA NO. 36965)				(DCA NO. 29558)				(DCA NO. 26965)											
PLUG IN CONTACT ASSY.																							

THE INFORMATION ON THIS DOCUMENT IS THE PROPERTY OF BHARAT HEAVY ELECTRICALS LIMITED. IT MUST NOT BE USED DIRECTLY OR INDIRECTLY IN ANY WAY DETRIMENTAL TO THE INTEREST OF THE COMPANY.

DRG NO 3 521 10 01 121

NOTES :-

- 1-JAW SHALL MOVE IN THE GUIDES SMOOTHLY.
- 2-CONTACTS ARE SHOWN AS PLUG IN CONDITION.

VAR	DESCRIPTION	NO. OF JAWS	GES NO.	WEIGHT OF CU.(kg)	PLATING TYPE
00	FDR 100X20TK CONNECTOR	16	409510129	1.504	SILVER PLATING
01	FDR 100X16TK CONNECTOR	16	409510130	1.504	SILVER PLATING
02	FDR 100X16TK CONNECTOR	16	409510131	1.504	TIN PLATING
03	FDR 75X12TK CONNECTOR	08	409510132	0.752	TIN PLATING
04	FDR 75X12TK CONNECTOR	12	409510133	1.128	TIN PLATING
05	FDR 75X12TK CONNECTOR	04	409301085	---	TIN PLATING
06	FDR 100X12TK CONNECTOR	04	409301084	---	SILVER PLATING
07	FDR 75X12TK CONNECTOR	12	409301086	1.504	SILVER PLATING
08	FDR 75X12TK CONNECTOR	04	-----	0.376	SILVER PLATING

VAR.08	VAR.07	VAR. 06	VAR. 05	VAR. 04	VAR. 03	VAR. 02	VAR. 01	VAR 00	REMARKS	VAR NO.	ITEM NO.	DESCRIPTION	DIS	DRAWING NO.	IT.NO.	MATERIAL CODE	A	UNIT	UNIT WT.
											019	PIN		45211001728	001				0.002
											018	SHUTTER		35211001724	004				0.002
											017	JAW BODY		35211001723	03				0.002
											016	SPRING		35211001729	001				0.002
											015	SPRING PULL ROD		35211001731	003				0.004
																			0.001
																			0.001

35211001721-R05-S08 REF.DRG.NO.

REV 06	DATE 05.01.22	ALT. CKD.	AT
		APPD.	AD

-VAR08 ADDED
(DCA NO. 37429)

ADDITIONAL INFORMATION

STATUS OF DRAWING

DISTRIBUTION OF PRINTS
 कार्यालय प्रति ----- 1
 दस डब्ल्यू. दम. - 3
 टी. सी. दवेस. ---- 1

TYPE OF PRODUCT OR NAME OF CUST/PROJ **VM-12 (BT-2)**

 BHARAT HEAVY ELECTRICALS LIMITED BHOPAL	DRN	NAME	SIGN	DATE	NO. OF VAR
	CKD	SSA		22.08.07	09
	APPD	D.BHATT		22.08.07	

INVENTORY NO.

REV 05	DATE 03.12.20	ALT. CKD.	AT
		APPD.	AD

-VAR07 ADDED
(DCA NO. 36965)

REV 04	DATE 11.08.10	ALT. CKD.	P.PARE
		APPD.	MANI
			DIVYA

-FOR IT-01 QTY. CHANGED TO 002NDS. FROM 003 NDS.
 -FOR IT-005 QTY. NULLIFIED FOR VAR.04
 -WEIGHT OF COPPER MENTIONED FOR VAR.00,01,02,03,04 IN SHT#08
 (DCA NO. 29558)

REV 03	DATE 22.08.07	DRN	SUS
		CKD	SSA
		APPD	DIVYA

VAR. 06 & SHT. 08 ADDED.
 BOM REARRANGED.
 (DCA NO. 26965)

DEPT SWE	UN. TOL.DIMGR.		SCALE 1:1	WEIGHT (KG.)	REF TO ASSY	ITEM MD.	NO.OF ITEMS
CODE 409					DRG NO		REV.
TITLE PLUG IN CONTACT ASSY.					3 521 10 01721		
					SHT.NO.	08	NO.OF SHT.

DRG NO 3 521 10 01 723

THE INFORMATION ON THIS DOCUMENT IS THE PROPERTY OF BHARAT HEAVY ELECTRICALS LIMITED. IT MUST NOT BE USED DIRECTLY OR INDIRECTLY IN ANY WAY DETRIMENTAL TO THE INTEREST OF THE COMPANY.

35211001723-R02-S01
REF.DRG.NO.

SIGN. & DATE

INVENTORY NO.

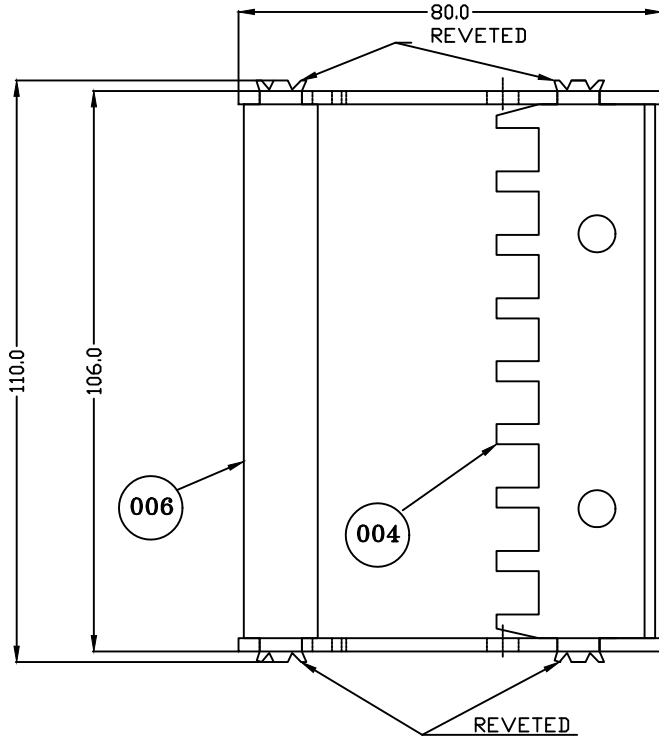
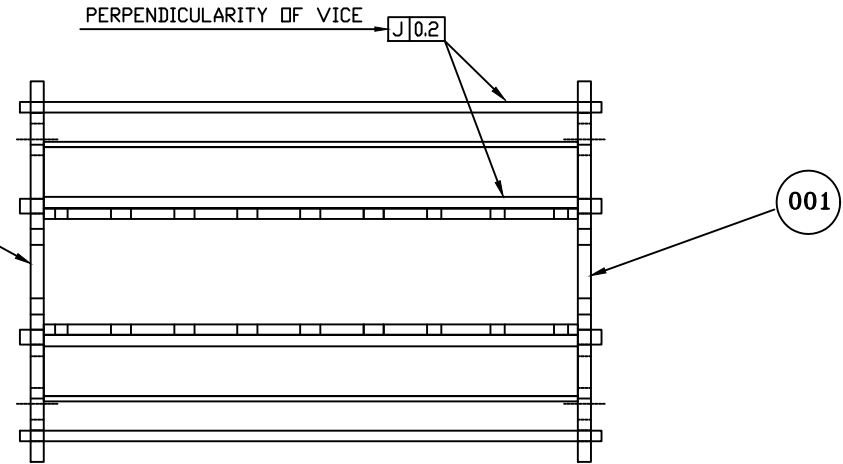
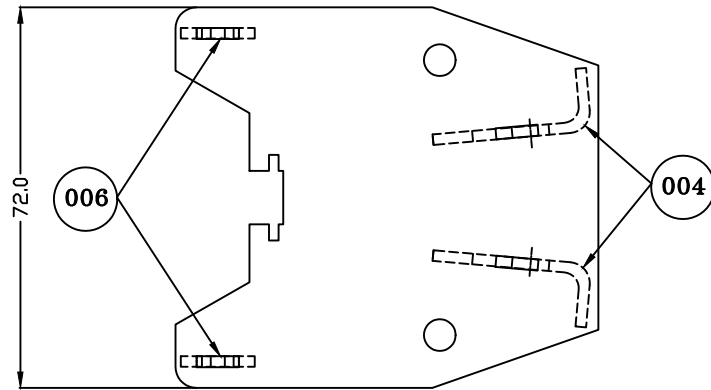

VAR-00
(SUTABLE FOR 20 TK.x100 WIDE CONNECTOR)

REFER SH. NO. 05 FOR BOM

ADDITIONAL INFORMATION				TYPE OF PRODUCT OR NAME OF CUST/PROJ										VM-12 (BT-II)					
STATUS OF DRAWING				DISTRIBUTION OF PRINTS										DISTRIBUTION OF PRINTS					
D. COPY-----1				D. COPY-----1										D. COPY-----1					
SWM-----3				SWM-----3										SWM-----3					
TCX-----1				TCX-----1										TCX-----1					
REV 01				DATE 17.08.07				ALT. SUS				CKD. SSA				APPD. ANITA			
REV 02				DATE 22.08.07				ALT. SUS				CKD. SSA				APPD. DIVYA			
VAR. 03 & SHT. 05 ADDED.				DRG. CORRECTED. & REDRAWN.				DEPT SWE				UN. TOL.DIM.GR.				SCALE 1:1			
(DCA NO. 26964)				(DCA NO. 26951)				CODE 409				BHARAT HEAVY ELECTRICALS LIMITED BHPAL				WEIGHT (KG.)			
								TITLE				JAW BODY				REF TO ASSY			
																35211001721			
																ITEM NO. 001			
																003			
																NO. OF ITEMS 007			
																DRG NO 3 521 10 01723			
																REV. 02			
																SHT.NO. 01			
																NO. OF SHT. 05			

THE INFORMATION ON THIS DOCUMENT IS THE PROPERTY OF BHARAT HEAVY ELECTRICALS LIMITED. IT MUST NOT BE USED DIRECTLY OR INDIRECTLY IN ANY WAY DETRIMENTAL TO THE INTEREST OF THE COMPANY.

35211001723-R02-S02
REF.DRG.NO.

SIGN. & DATE

INVENTORY NO.

DRG NO 3 521 10 01 723

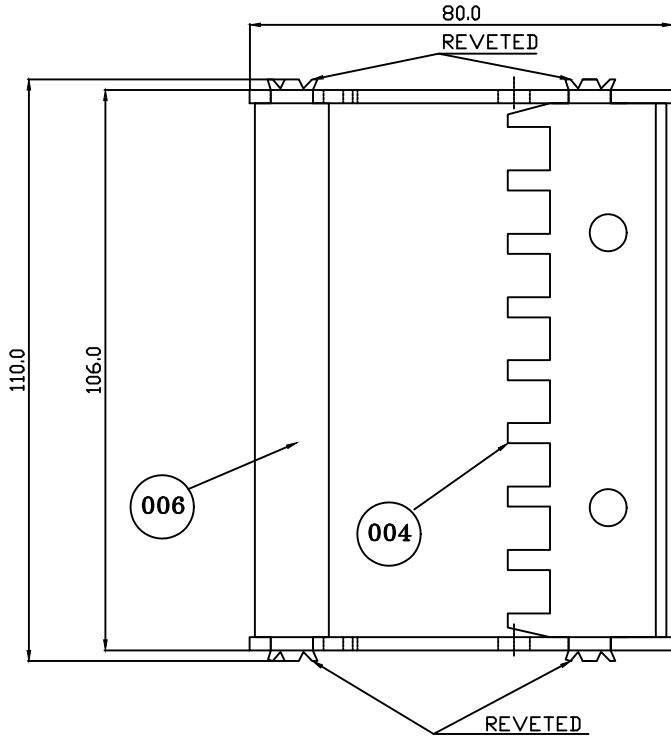
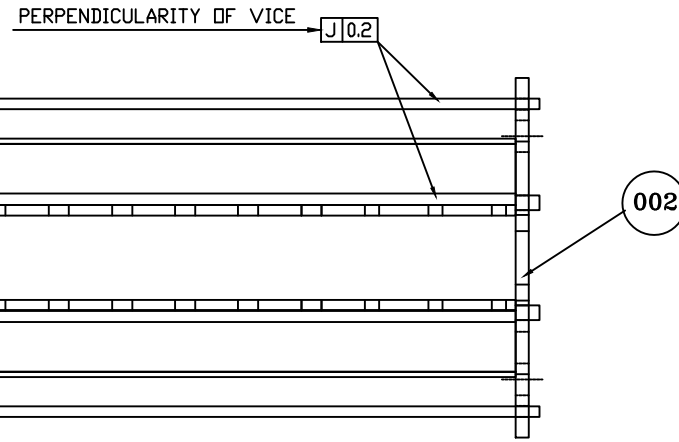
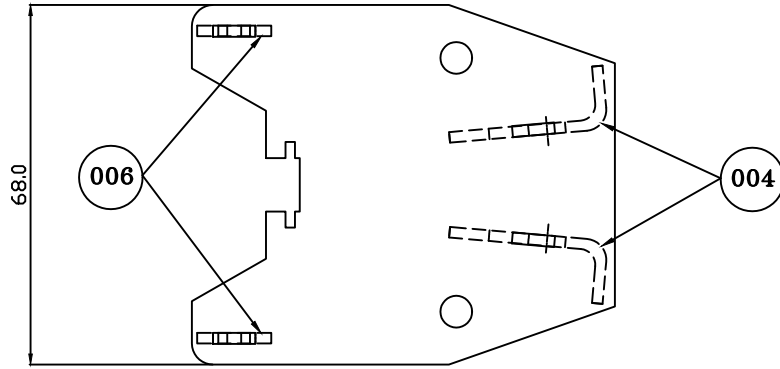

VAR-01
(SUTABLE FOR 16 TK.x100 WIDE CONNECTOR)

REFER SH. NO. 05 FOR BOM

ADDITIONAL INFORMATION				TYPE OF PRODUCT OR NAME OF CUST/PROJ				VM-12 (BT-II)			
STATUS OF DRAWING				DISTRIBUTION OF PRINTS				BHARAT HEAVY ELECTRICALS LIMITED BHPAL			
D. COPY-----1				SWM-----3				DRN			
TCX-----1				UN. TOL.DIM.GR.				SCALE			
REV 01 17.08.07				DEPT SWE				WEIGHT (KG.)			
ALT. SUS				CKD. SSA				NAME			
APPD. ANITA				CODE 409				SIGN			
VAR. 03 & SHT. 05 ADDED.				DRG. CORRECTED. & REDRAWN.				DATE			
(DCA NO. 26964)				(DCA NO. 26951)				NO. OF VAR			
				TITLE				REF TO ASSY			
				JAW BODY				ITEM NO. 001T 003			
								NO. OF ITEMS			
								DRG NO 3 521 10 01723			
								REV.			
								SHT.NO. 02			
								NO. OF SHT. 05			

THE INFORMATION ON THIS DOCUMENT IS THE PROPERTY OF BHARAT HEAVY ELECTRICALS LIMITED. IT MUST NOT BE USED DIRECTLY OR INDIRECTLY IN ANY WAY DETRIMENTAL TO THE INTEREST OF THE COMPANY.

35211001723-R02-S03
REF.DRG.NO.

SIGN. & DATE

INVENTORY NO.

DRG NO 3 521 10 01 723

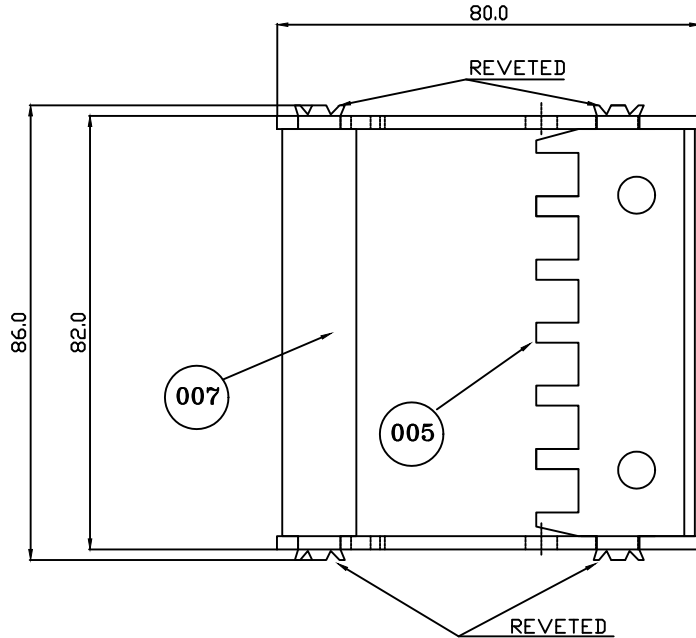
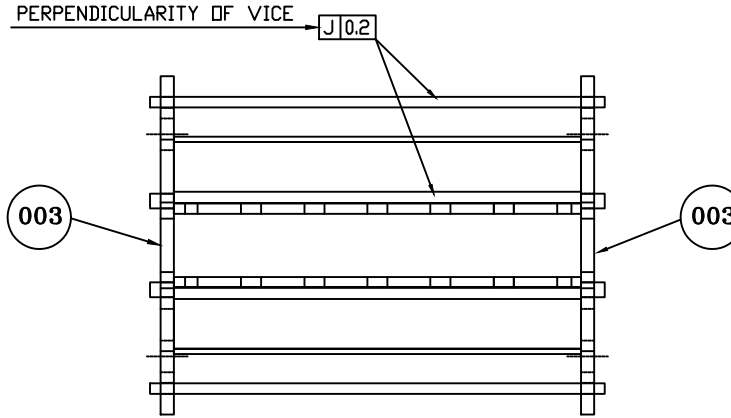
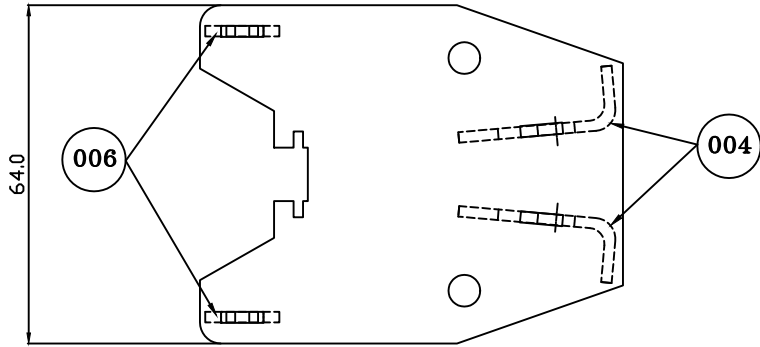

VAR-02
(SUTABLE FOR 12TK.x75 WIDE CONNECTOR)

REFER SH. NO. 05 FOR BOM

ADDITIONAL INFORMATION				TYPE OF PRODUCT OR NAME OF CUST/PROJ										VM-12 (BT-II)													
STATUS OF DRAWING				 BHARAT HEAVY ELECTRICALS LIMITED BHPAL										DRN	NAME		SIGN	DATE		NO. OF VAR							
DISTRIBUTION OF PRINTS														CKD	SSA			22.08.07		04							
D. COPY-----1 SWM-----3 TCX-----1														APPD	D.BHATT			22.08.07									
REV 02		DATE 22.08.07		ALT. SUS		CKD. SSA		APPD. DIVYA		REV 01		DATE 17.08.07		ALT. SUS		CKD. SSA		APPD. ANITA		DEPT SWE	UN. TOL.DIM.GR.	SCALE 1:1	WEIGHT (KG.)	REF TO ASSY		ITEM NO. 001T 003	NO. OF ITEMS
		VAR. 03 & SHT. 05 ADDED.				DRG. CORRECTED. & REDRAWN.														TITLE		JAW BODY		DRG NO 3 521 10 01723		REV. 02	
		(DCA NO. 26964)				(DCA NO. 26951)																SHT.NO. 03		NO. OF SHT. 05			

THE INFORMATION ON THIS DOCUMENT IS THE PROPERTY OF BHARAT HEAVY ELECTRICALS LIMITED. IT MUST NOT BE USED DIRECTLY OR INDIRECTLY IN ANY WAY DETRIMENTAL TO THE INTEREST OF THE COMPANY.

35211001723-R02-S04
REF.DRG.NO.

SIGN. & DATE

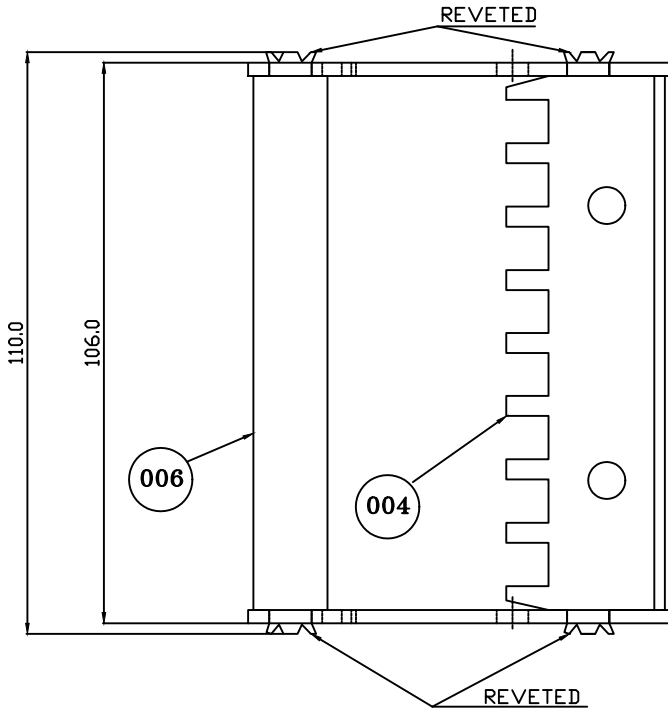
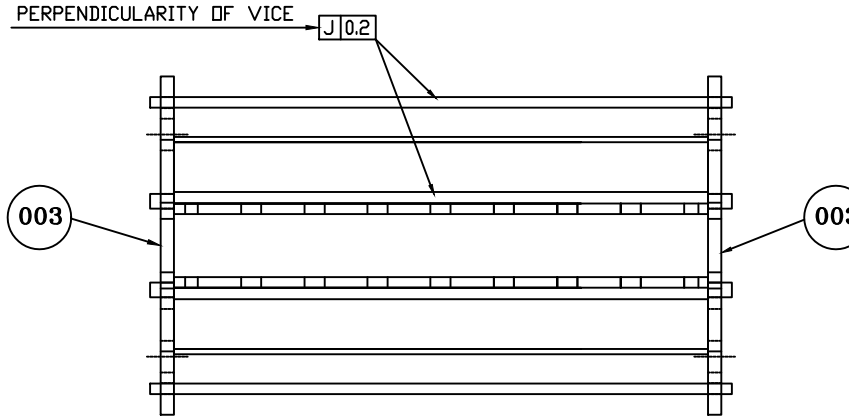
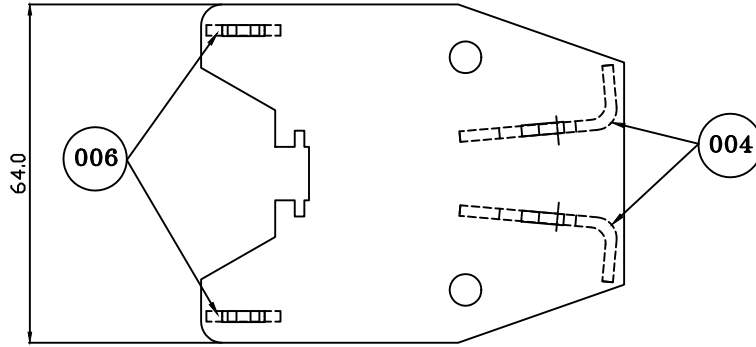

INVENTORY NO.

DRG NO 3 521 10 01 723



VAR-03
(SUTABLE FOR 12 TK.x100 WIDE CONNECTOR)

REFER SH. NO. 05 FOR BOM

ADDITIONAL INFORMATION				TYPE OF PRODUCT OR NAME OF CUST/PROJ				VM-12 (BT-II)																	
STATUS OF DRAWING				DISTRIBUTION OF PRINTS				 BHARAT HEAVY ELECTRICALS LIMITED BHPAL																	
D. COPY-----1 SWM-----3 TCX-----1				DRN CKD APPD				<table border="1"> <tr> <th>NAME</th> <th>SIGN</th> <th>DATE</th> <th>NO. OF VAR</th> </tr> <tr> <td>SUS</td> <td></td> <td>22.08.07</td> <td rowspan="3">04</td> </tr> <tr> <td>SSA</td> <td></td> <td>22.08.07</td> </tr> <tr> <td>D.BHATT</td> <td></td> <td>22.08.07</td> </tr> </table>				NAME	SIGN	DATE	NO. OF VAR	SUS		22.08.07	04	SSA		22.08.07	D.BHATT		22.08.07
NAME	SIGN	DATE	NO. OF VAR																						
SUS		22.08.07	04																						
SSA		22.08.07																							
D.BHATT		22.08.07																							
REV 02	DATE 22.08.07	ALT. CKD. APPD.	SUS SSA DIVYA	REV 01	DATE 17.08.07	ALT. CKD. APPD.	SUS SSA ANITA	DEPT SWE CODE 409	UN. TOL.DIM.GR.	 SCALE 1:1	WEIGHT (KG.)	REF TO ASSY 35211001721	ITEM MD. 001T 003	NO. OF ITEMS 007											
VAR. 03 & SHT. 05 ADDED. (DCA NO. 26964)				DRG. CORRECTED. & REDRAWN. (DCA NO. 26951)				TITLE				JAW BODY DRG NO 3 521 10 01723 SHT.NO. 04 NO. OF SHT. 05													

THE INFORMATION ON THIS DOCUMENT IS THE PROPERTY OF BHARAT HEAVY ELECTRICALS LIMITED. IT MUST NOT BE USED DIRECTLY OR INDIRECTLY IN ANY WAY DETRIMENTAL TO THE INTEREST OF THE COMPANY.

35211001723-R02-S05
REF.DRG.NO.

SIGN. & DATE

INVENTORY NO.

DRG NO 3 521 10 01 723

NOTE :-

- ITEM 1,2, & 3 ARE TO BE RIVETTED AS SHOWN. RIVETTED SURFACE TO BE COVERED WITH ANTI RUST VARNISH.

VAR. 03	VAR. 02	VAR. 01	VAR 00	REMARKS	VAR NO.	ITEM NO.	DESCRIPTION	STD	DRAWING NO.	IT.NO.	MATERIAL CODE	A	UNIT	UNIT WT.
										VAR	MATL. SPCN.	C		QTY
-	002	-	-			007	LINK		35211001726	002				0.016
														001
002	-	002	002			006	LINK		35211001726	001				0.021
														001
-	002	-	-			005	SHUTTER		35211001728	002				0.040
														001
002	-	002	002			004	SHUTTER		35211001728	001				0.052
														001
002	002	-	-			003	SIDE SHEET		35211001725	003				0.082
														001
-	-	002	-			002	SIDE SHEET		35211001725	002				0.087
														001
-	-	-	002			001	SIDE SHEET		35211001725	001				0.092
														001

ADDITIONAL INFORMATION				TYPE OF PRODUCT OR NAME OF CUST/PROJ																			
STATUS OF DRAWING				VM-12 (BT-II)																			
DISTRIBUTION OF PRINTS				 BHARAT HEAVY ELECTRICALS LIMITED BHPAL						DRN		NAME		SIGN		DATE		NO. OF VAR					
कार्यालय प्रति ---- 1 दस. डब्ल्यू. दम. - 3 टी. सी. दवेस. ---- 1										CKD		SSA				22.08.07		04					
										APPD		D.BHATT				22.08.07							
REV 02		DATE 22.08.07		ALT. SUS		REV 01		DATE 17.08.07		DEPT SWE		UN. TOL.DIMGR.		SCALE 1:1		WEIGHT (KG.)		REF TO ASSY		ITEM NO.		NO. OF ITEMS	
				CKD. SSA				CKD SSA		409								35211001721		001		007	
				APPD. DIVYA				APPD ANITA										35211001721		003			
VAR. 03 & SHT. 05 ADDED.				DRG. CORRECTED. & REDRAWN.				TITLE															
(DCA NO. 26964)				(DCA NO. 26951)				JAW BODY															
														DRG NO		3 521 10 01723		REV.		02			
														SHT.NO.		05		NO. OF SHT.		05			

INVENTORY No. 35211001724-R01-S01 REF. DRG. NO. 35211001724-R01-S01 THE INFORMATION ON THIS DOCUMENT IS THE PROPERTY OF BHARAT HEAVY ELECTRICALS LIMITED. IT MUST NOT BE USED DIRECTLY OR INDIRECTLY IN ANY WAY DETRIMENTAL TO THE INTEREST OF THE COMPANY.

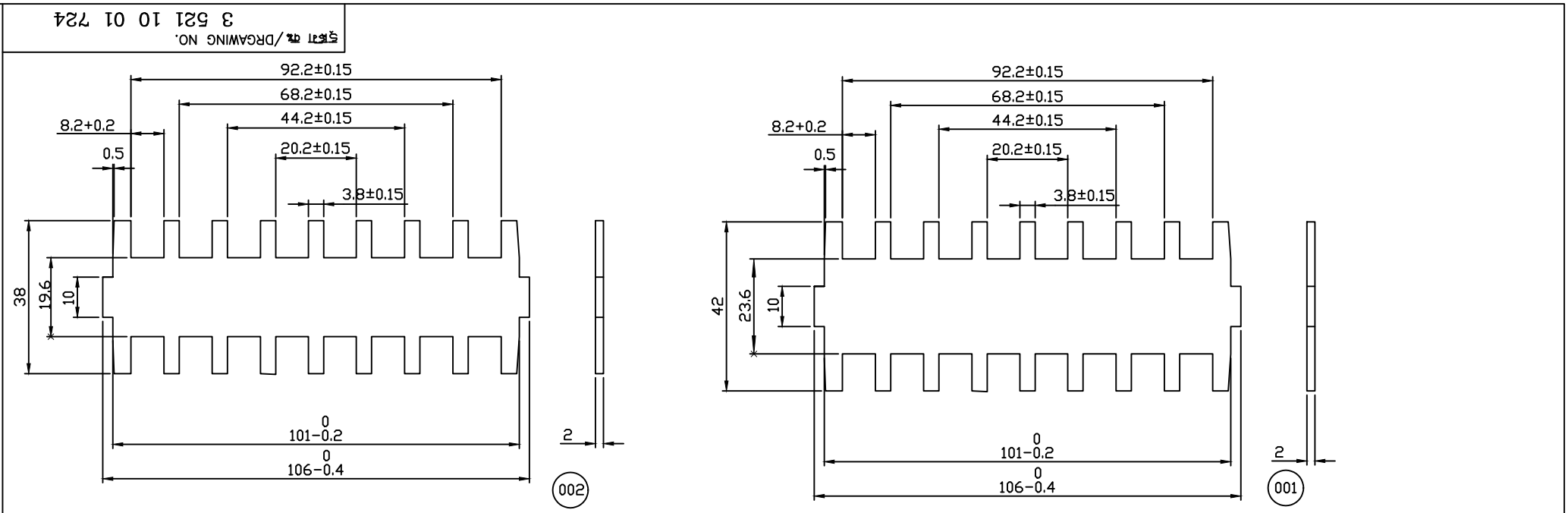

VAR. NO.	REMARKS	VAR. NO.	ITEM NO.	DESCRIPTION	STD.	DRAWING NO.	IT. NO.	MATL. CODE.	A	C	UNIT	UNIT WT.	GS.
			004	2TK.X34X106 LG H.R.C.S. SHEET.				AA 1011713110				0.0566	
								AA 10113				001	
			003	2TK.X34X82 LG H.R.C.S. SHEET.				AA 1011713110				0.036	
								AA 10113				001	
			002	2TK. x38x106 LG H.R.C.S. SHEET.				AA 1011713110				0.052	
								AA 10113				001	
			001	2TK. x42x106 LG H.R.C.S. SHEET.				AA 1011713110				0.057	
								AA 10113				001	
							VAR	MATL. SPCN.				QTY.	

ADDITIONAL INFORMATION				TYPE OF PRODUCT OR VM-12 (BT-II)											
STATUS OF DRAWING				NAME OF CUSTOMER/PROJECT											
DISTRIBUTION OF PRINTS				BHARAT HEAVY ELECTRICALS LTD. BHOPAL				खनपा DRN. G.PRASAD		हस्ता/SIGN.		दि./DATE 07.04.01		वेरि की संख्या NO. OF VAR.	
OFFICE COPY - 1								जीचा CKD. S.S.A.		29.05.01					
SWM - 3								स्वकृत APPD. D.BHATT		29.05.01					
TCX (SWM) - 1				विभाग DEPT. SWE		अनुपात SCALE 1:1		भार कि. ग्रा. WEIGHT (K.G.)		असे. ड्रॉग का संदर्भ REF. TO ASSY. 35211001721		मद संख्या ITEM NO. 004		मद संख्या NO. OF ITEM 004	
REV 01 DATE 22.08.07				अं.टल.नाप की त्रुटि UNTO. DIMS. GR.		कोड CODE. 409		शीट क्र./SHT.NO 01		ड्रॉग क्र./DRGAWING NO. 3 521 10 01 724		पुन./REV. 01		शीटों की सं./NO.OF.SHT. 02	
ITEM 004 & SHT. 02 ADDED.				/TITLE SHUTTER											
(DCA NO. 26963)															

35211001724-R01-S02 REF. DRG. NO.

SIGN. & DATE

INVENTORY No.

3 521 10 01 724
ड्रॉइंग नं./DRGAWING NO.

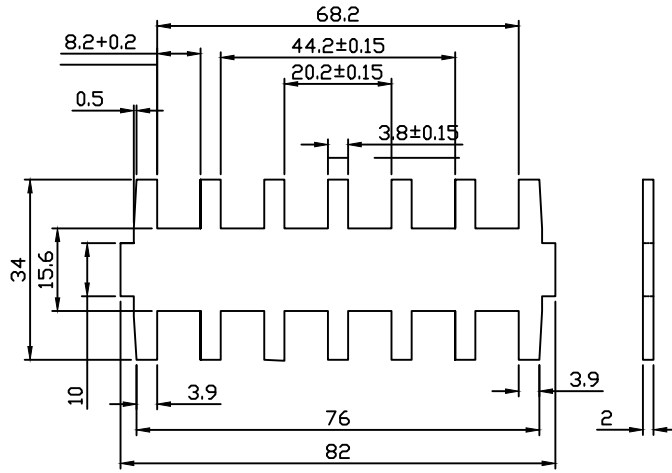

003

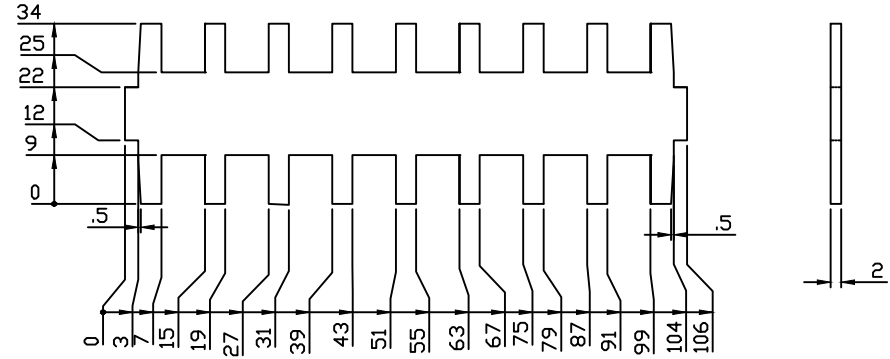

004

UNSPECIFIED TOLERANCES SHALL BE :-
FOR MACHINING MEDIUM AA0230208.
FOR SHEARING OF SHEETS AS PER AA0230409.

FINISH:-

ZINC PLATE & PASSIVATE TO AA0673603 & AA0673604.
(0.013 TK. MIN.)

OLD DRG-35964011102

ADDITIONAL INFORMATION		TYPE OF PRODUCT OR VM-12 (BT-II)						
STATUS OF DRAWING		NAME OF CUSTOMER/PROJECT						
DISTRIBUTION OF PRINTS		BHARAT HEAVY ELECTRICALS LTD. BHOPAL		खनपा DRN.	नाम /NAME	हस्ता/SIGN.	दि./DATE	ड्रॉइंग की संख्या NO. OF VAR.
OFFICE COPY - 1				जांचा CKD.	SUS		22.08.07	
SWM - 3				स्वीकृत APPD.	SSA	D.BHATT	22.08.07	
TCX (SWM) - 1		विभाग DEPT. SWE	अन.टोल.नाप की त्रुटि UNTOL. DIMS. GR.	अनुपात SCALE	भार कि. ग्र. WEIGHT (K.G.)	असे. ड्रॉइंग का संदर्भ REF. TO ASSY.	मद संख्या ITEM NO.	मद संख्या NO. OF ITEM
REV	DATE	ALTERED	SUS	1:1				
01	22.08.07	CHECKED	SSA					004
		APPROVED	DIVYA					
ITEM 004 & SHT. 02 ADDED.		/TITLE		SHUTTER		ड्रॉइंग नं./DRGAWING NO.		पुन./ REV.
(DCA NO. 26963)						3 521 10 01 724		01
						शीट नं./SHT.NO 02		शीटों की सं./NO.OF.SHT. 02

THE INFORMATION ON THIS DOCUMENT IS THE PROPERTY OF BHARAT HEAVY ELECTRICALS LIMITED. IT MUST NOT BE USED DIRECTLY OR INDIRECTLY IN ANY WAY DETRIMENTAL TO THE INTEREST OF THE COMPANY.

35211001725-R00-S01
REF.DRG.NO.

SIGN. & DATE

INVENTORY NO.

DRG NO 3 521 10 01 725

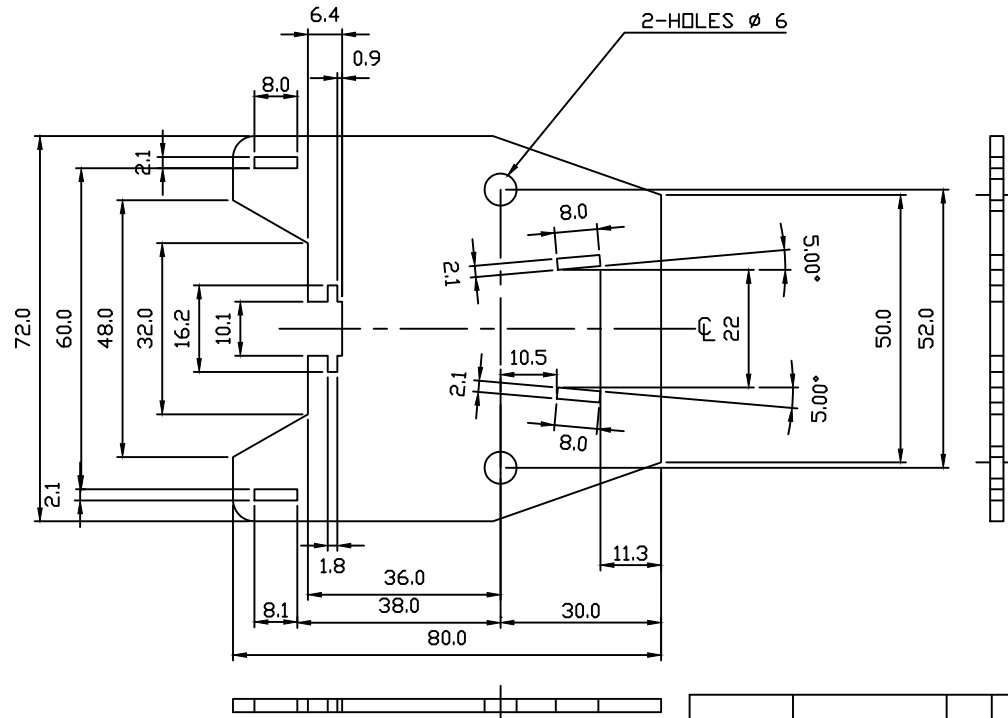

001

UNSPECIFIED TOLERANCES SHALL BE :-
FOR MACHINING MEDIUM AA0230208.
FOR SHEARING OF PLATES/SHEETS AS PER AA0230409.

FINISH :-
ZINC PLATE & PASSIVATE TO AA0673603 & AA0673604.
(0.013 TK. MIN.)

NOTES :-
TOLERANCE ±0.2 UNLESS OTHER WISE STATED

OLD REF.-35964011111

VAR 00	REMARKS	VAR NO.	ITEM NO.	DESCRIPTION	STD	DRAWING NO.	IT.ND.	MATERIAL CODE	A	UNIT	UNIT WT.
							VAR	MATL. SPCN.	C		QTY
			003	2.5TK. x 64 x 80 LG. HRC.STL.SH.PICKLED				BP 10117198026			0.092
								BP 10198			001
			002	2.5TK. x 68 x 80 LG. HRC.STL.SH.PICKLED				BP 10117198026			0.092
								BP 10198			001
			001	2.5TK. x 72 x 80 LG. HRC.STL.SH.PICKLED				BP 10117198026			0.092
								BP 10198			001

ADDITIONAL INFORMATION				TYPE OF PRODUCT OR NAME OF CUST/PROJ		VM-12(BT.II)									
STATUS OF DRAWING				NAME		SIGN	DATE	NO. OF VAR							
DISTRIBUTION OF PRINTS				DRN		G.PRASAD	07.04.01	-							
REV				CKD		S.S.A.	29.05.01	-							
DATE				APPD		D.BHATT	29.05.01	-							
DRN				UN. TOL.DIMGR.		SCALE		WEIGHT (KG.)		REF TO ASSY		ITEM NO.		NO. OF ITEMS	
CKD				409		1:1				3521001723		001		003	
APPD										DRG NO		REV.			
										3 521 10 01 725		00			
										SHT.NO.		01		NO. OF SHT.	
														03	
												BHARAT HEAVY ELECTRICALS LIMITED BHPAL			
TITLE <h1 style="margin: 0;">SIDE SHEET</h1>															

THE INFORMATION ON THIS DOCUMENT IS THE PROPERTY OF BHARAT HEAVY ELECTRICALS LIMITED. IT MUST NOT BE USED DIRECTLY OR INDIRECTLY IN ANY WAY DETRIMENTAL TO THE INTEREST OF THE COMPANY.

35211001725-R00-S02
REF.DRG.NO.

SIGN. & DATE

INVENTORY NO.

DRG NO 3 521 10 01 725

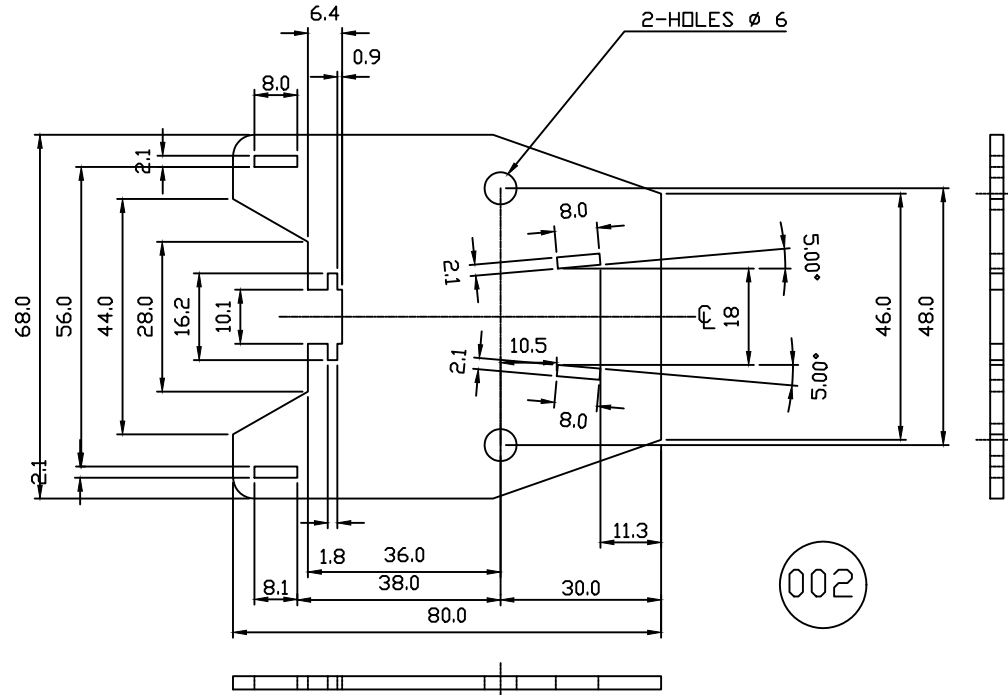

VAR 00	REMARKS	VAR NO.	ITEM NO.	DESCRIPTION	STD	DRAWING NO.	IT.ND.	MATERIAL CODE	A	UNIT	UNIT WT.
							VAR	MATL. SPCN.	C		QTY

ADDITIONAL INFORMATION				TYPE OF PRODUCT OR NAME OF CUST/PROJ								VM-12									
STATUS OF DRAWING				DISTRIBUTION OF PRINTS				Bharat Heavy Electricals Limited Bhopal				DRN		NAME		SIGN		DATE		NO. OF VAR	
U				कार्यालय प्रति ---- 1 दस. डब्ल्यू. दम. - 3 टी. सी. दवेस. ---- 1				BHEE				G.PRASAD		[Signature]		07.04.01		-			
												CKD		S.S.A.		[Signature]		29.05.01			
												APPD		D.BHATT		[Signature]		29.05.01			
REV	DATE	DRN	DEPT	SWE	UN. TOL.DIMGR.	SCALE	WEIGHT (KG.)	REF TO ASSY	ITEM	NO. OF											
		CKD	409			1:1		3521001723	MP. 001	003											
		APPD						DRG NO													
								3 521 10 01 725													
								SHT.NO.	02	NO. OF SHT.											

SIDE SHEET

THE INFORMATION ON THIS DOCUMENT IS THE PROPERTY OF BHARAT HEAVY ELECTRICALS LIMITED. IT MUST NOT BE USED DIRECTLY OR INDIRECTLY IN ANY WAY DETRIMENTAL TO THE INTEREST OF THE COMPANY.

35211001725-R00-S03
REF.DRG.NO.

SIGN. & DATE

INVENTORY NO.

DRG NO 3 521 10 01 725

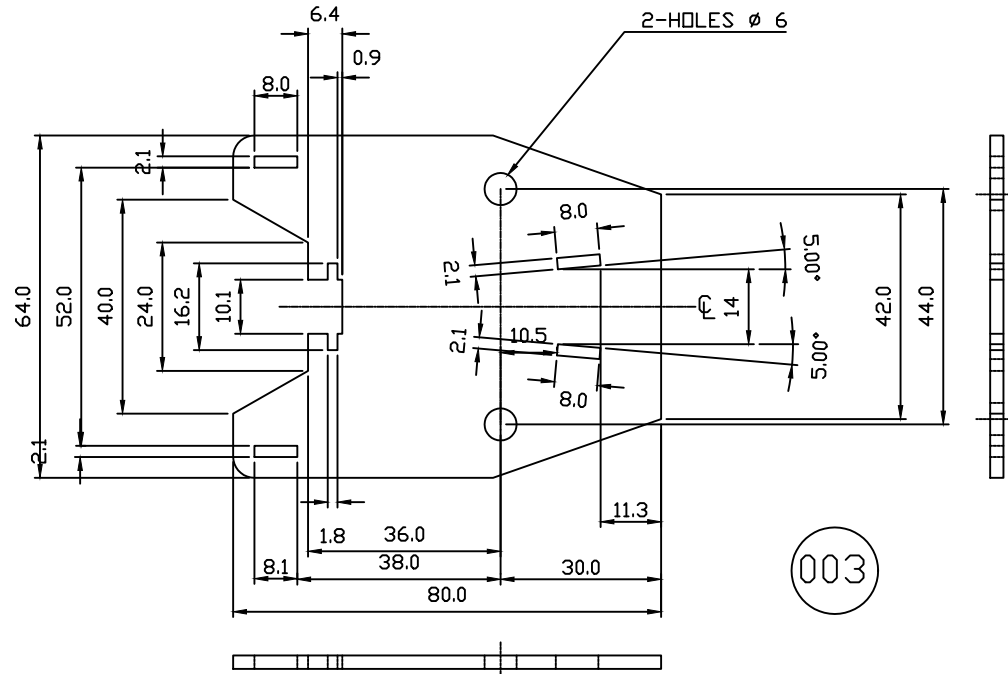

VAR 00	REMARKS	VAR NO.	ITEM NO.	DESCRIPTION	STD	DRAWING NO.	IT.ND.	MATERIAL CODE	A	UNIT	UNIT WT.
							VAR	MATL. SPCN.	C		QTY

ADDITIONAL INFORMATION				TYPE OF PRODUCT OR NAME OF CUST/PROJ							
STATUS OF DRAWING 'U'				VM-12(BT-2)							
DISTRIBUTION OF PRINTS कार्यालय प्रति ---- 1 एस. डब्ल्यू. एम. - 3 टी. सी. एच.एस. ---- 1				 BHARAT HEAVY ELECTRICALS LIMITED BHOPAL		DRN	NAME	SIGN	DATE	NO. OF VAR	
						CKD	S.S.A.		29.05.01	-	
						APPD	D.BHATT		29.05.01	-	
REV	DATE	DRN	DEPT	UN. TOL.DIMGR.	SCALE	WEIGHT (KG.)	REF TO ASSY	ITEM	NO. OF ITEMS		
		CKD	SWE		1:1		3521001723	MP. 001	003		
		APPD	CODE				DRG NO	003	REV.		
			409				3 521 10 01 725		00		
TITLE							SHT.NO.	03	NO. OF SHT.	03	
SIDE SHEET											

INVENTORY No. SIGN. & DATE REF. DRG. NO. 35211001726-R00-S01 THE INFORMATION ON THIS DOCUMENT IS THE PROPERTY OF BHARAT HEAVY ELECTRICALS LIMITED. IT MUST NOT BE USED DIRECTLY OR INDIRECTLY IN ANY WAY DETRIMENTAL TO THE INTEREST OF THE COMPANY.

3 521 10 01 726
 ड्राइंग नं./DRAWING NO.

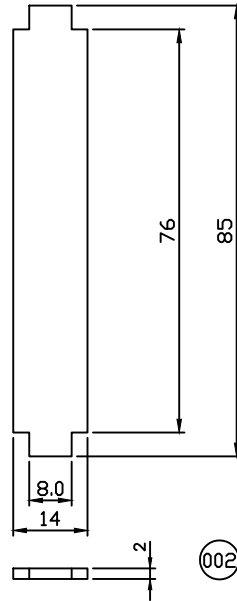
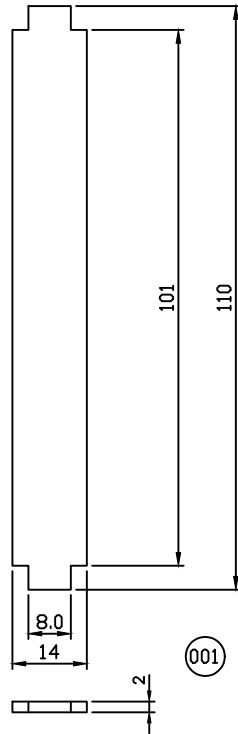

UNSPECIFIED TOLERANCES SHALL BE :-
 FOR MACHINING MEDIUM AA0230208.
 FOR SHEARING OF SHEETS AS PER AA0230409.

FINISH:-

ZINC PLATE & PASSIVATE TO AA0673603 & AA0673604.
 (0.013 TK. MIN.)

OLD.DRG.-35964011114

VAR. NO.	REMARKS	VAR. NO.	ITEM NO.	DESCRIPTION	STD.	DRAWING NO.	IT. NO.	MATL. CODE.	A	C	UNIT	UNIT WT.	GS.
			002	2TKx14x 85.2 LG H.R.S. SHEET				AA 1011713110				0.016	
								AA 10113				001	
			001	2TKx14x 110 LG H.R.C.S. SHEET				AA 1011713110				0.021	
								AA 10113				001	
							VAR	MATL. SPCN.				QTY.	

ADDITIONAL INFORMATION

STATUS OF DRAWING

DISTRIBUTION OF PRINTS

OFFICE COPY - 1
 SWGR SHOPS - 3
 TCX BLIV - 1

REV DATE ALTERED
 CHECKED
 APPROVED

TYPE OF PRODUCT OR

VM-12

NAME OF CUSTOMER/PROJECT



BHARAT HEAVY ELECTRICALS LTD.
 BHOPAL

खनपा DRN.	नाम /NAME	हस्ता/SIGN.	दि./DATE	वे.ि की संख्या NO. OF VAR.
	G.PRASAD		07.04.01	
जांचा CKD.	S.S.A.		29.05.01	
स्वीकृत APPD.	D.BHATT		29.05.01	

विभाग DEPT. SWE
 कोड CODE. 409

अन.टल.माप की त्रुटि UNTOL. DIMS. GR.

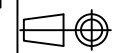

अनुपात SCALE 1:1

भार कि. ग्रा. WEIGHT (K.G.)

असे. ड्राइंग का संदर्भ REF. TO ASSY.

मद संख्या ITEM NO. 006 & 007
 मद संख्या NO. OF ITEM 002

/TITLE

LINK

ड्राइंग नं./DRGAWING NO.

3 521 10 01 726

पुन./REV. 00

शीट नं./SHT.NO 101 शीटों की सं./NO.OF.SHT.1 01

3 521 10 01 727
ON DRG/DRG NO. 35211001727

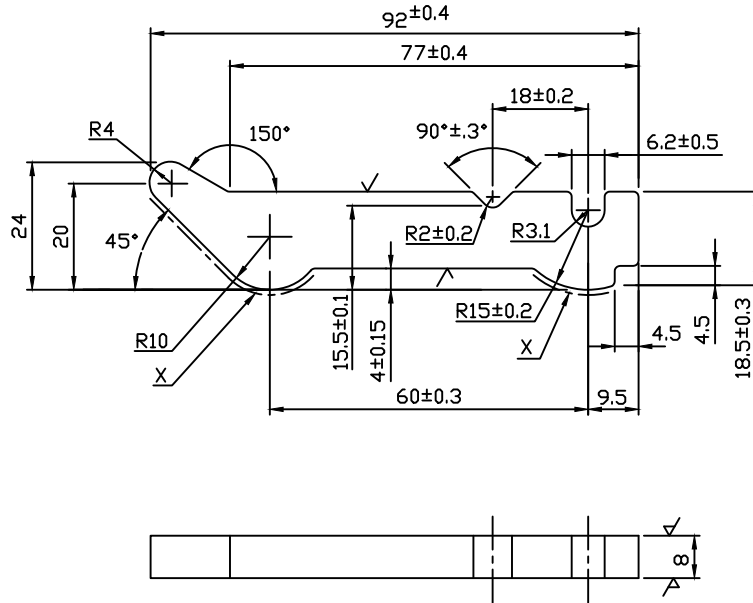

001 002

UNSPECIFIED TOLERANCES SHALL BE :-
FOR MACHINING MEDIUM AA0230208.
FOR SHEARING OF PLATES AS PER AA0230409.

NOTE :-

- WHEREEVER RADIUS IS NOT GIVEN TAKE R=1.6
- SURFACES MARKED 'X' THUS ARE TO BE OF 6 MICRONS FINISH.
- ALL THE SHARP CORNERS ARE TO BE ROUNDED OFF BY 1mm. EXCEPT MARKED THUS 'X'
- FINISH :-
A- IT. 001:- SILVER PLATE (0.13TK.) TO PROCESS SPEC. NO.0673613.
B- IT. 002:- TIN PLATED TO (0.020TK.) PROCESS SPEC. NO. AA 0673602.
C- SURFACE AREA :- 6670 SQ.MM.

OLD DRG.-35964011101

VAR. NO.	REMARKS	VAR. NO.	ITEM NO.	DESCRIPTION	QTY.	DRAWING NO.	IT. NO.	MATL. CODE.	A	UNIT	UNIT WT.	GS.
			002	8TK. x 25 x 92LG. HARD COPPER STRIP	1			AA 1201903138			0.094	
								AA 12003			001	
			001	8TK. x 25 x 92LG. HARD COPPER STRIP	1			AA 1201903138			0.094	
								AA 12003			001	

INVENTORY No. 35211001727-R00-S01
 SIGN. & DATE
 REF. DRG. NO. 35211001727-R00-S01
 THE INFORMATION ON THIS DOCUMENT IS THE PROPERTY OF BHARAT HEAVY ELECTRICALS LIMITED. IT MUST NOT BE USED DIRECTLY OR INDIRECTLY IN ANY WAY DETRIMENTAL TO THE INTEREST OF THE COMPANY.

ADDITIONAL INFORMATION				TYPE OF PRODUCT OR NAME OF CUSTOMER/PROJECT									
STATUS OF DRAWING				VM12									
DISTRIBUTION OF PRINTS				BHARAT HEAVY ELECTRICALS LTD. BHOPAL				खनपा DRN. G.PRASAD नाम /NAME Sd/- हस्ता/SIGN. Sd/- दि./DATE 07-04-01		चेकिंग CKD. SSA नाम /NAME Sd/- हस्ता/SIGN. Sd/- दि./DATE 29-05-01		स्वीकृत APPD. D.BHATT नाम /NAME Sd/- हस्ता/SIGN. Sd/- दि./DATE 29-05-01	
REV	DATE	ALTERED	P.PARE	विभाग DEPT. SWE	अन.टोल.नाप की त्रुटि UN.TOL. DIMS. GR.	अनुपात SCALE	भार कि. ग्र. WEIGHT (K.G.)	उसे. ड्रॉइंग का संदर्भ REF. TO ASSY.	मद संख्या ITEM NO.	मद संख्या NO. OF ITEM			
01	11.08.10	CHECKED	AKHIL	कोड CODE. 409		NTS		35211001721	008 & 009	002			
ACTUAL FINISHED WEIGHT OF COPPER UPDATED.				/TITLE				ड्रॉइंग क्र./DRGAWING NO.		पुन./REV.			
(DCA 29920)				JAW CONTACT				3 521 10 01727		00			
								शीट क्र./SHT.NO 01		शीटों की सं./NO.OF.SHT. 01			

THE INFORMATION ON THIS DOCUMENT IS THE PROPERTY OF BHARAT HEAVY ELECTRICALS LIMITED. IT MUST NOT BE USED DIRECTLY OR INDIRECTLY IN ANY WAY DETRIMENTAL TO THE INTEREST OF THE COMPANY.

DRG NO 3 521 10 01 728

UNSPECIFIED TOLERANCES SHALL BE :-
FOR MACHINING MEDIUM AA0230208.
FOR SHEARING OF SHEETS AS PER AA0230409.

FINISH:-

ZINC PLATE & PASSIVATE TO AA0673603 & AA0673604.
(0.013 TK. MIN.)

REF DRG.-35964011112

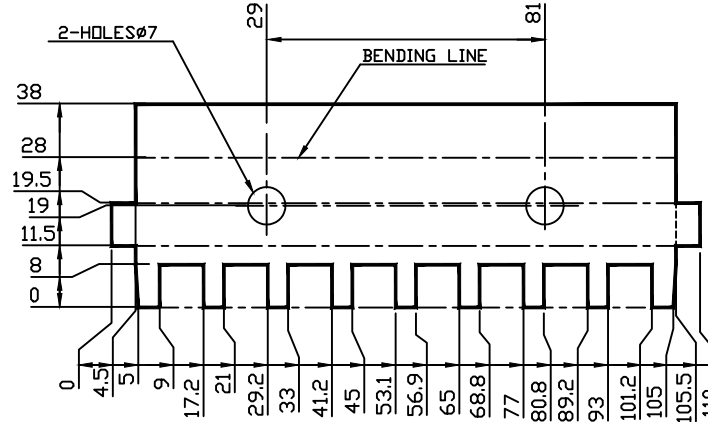
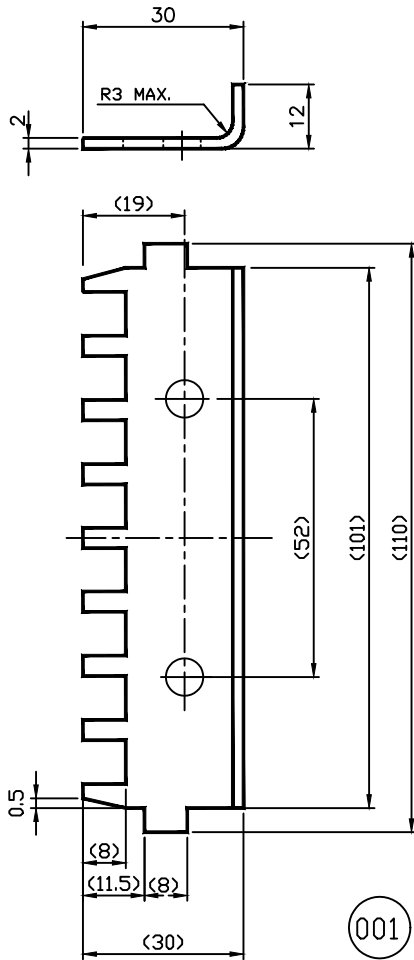

DEVELOPMENT OF ITEM-001

-	-	001	2TK. x 38 x 110 LG. H.R.C. STEEL SHEET		AA 1011713110	0.052					
VAR 00	REMARKS	VAR NO.	ITEM NO.	DESCRIPTION	STD	DRAWING NO.	IT.NO.	MATERIAL CODE	A	UNIT	UNIT WT.
							VAR	MATL. SPCN.	C		QTY

35211001728-R00-S01
REF.DRG.NO.

SIGN. & DATE

INVENTORY NO.

ADDITIONAL INFORMATION		
STATUS OF DRAWING		
DISTRIBUTION OF PRINTS कार्यालय प्रति ---- 1 दस. डब्ल्यू. दम. - 3 टी. सी. दवेस. ---- 1		
REV	DATE	DRN CKD APPD

TYPE OF PRODUCT OR NAME OF CUST/PROJ

VM-12



BHARAT HEAVY ELECTRICALS LIMITED
BHOPAL

DRN	NAME	SIGN	DATE	NO. OF VAR
G.PRASAD	G.PRASAD		07.04.01	
CKD	S.S.A.		29.05.01	
APPD	D.BHATT		29.05.01	

DEPT	UN. TOL.DIMGR.	SCALE	WEIGHT (KG.)	REF TO ASSY	ITEM NO.	NO. OF ITEMS
SWE		1:1		35211001723	004 & 005	002
CODE				DRG NO		REV.
409				3 521 10 01 728		00
TITLE				SHT.NO.	NO. OF SHT.	
SHUTTER				01	02	

THE INFORMATION ON THIS DOCUMENT IS THE PROPERTY OF BHARAT HEAVY ELECTRICALS LIMITED. IT MUST NOT BE USED DIRECTLY OR INDIRECTLY IN ANY WAY DETRIMENTAL TO THE INTEREST OF THE COMPANY.

35211001728-R00-S02
REF.DRG.NO.

SIGN. & DATE

INVENTORY NO.

DRG NO 3 521 10 01 728

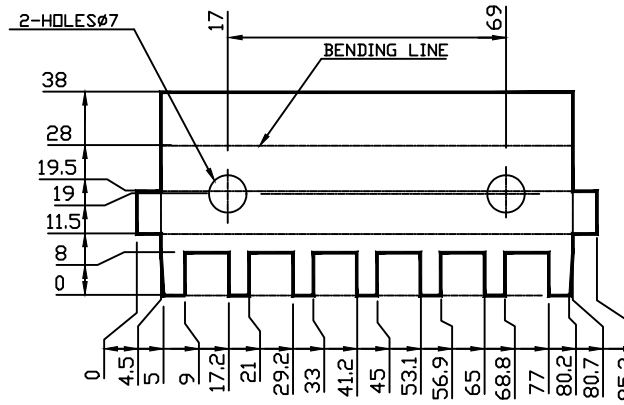
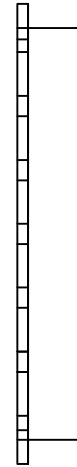
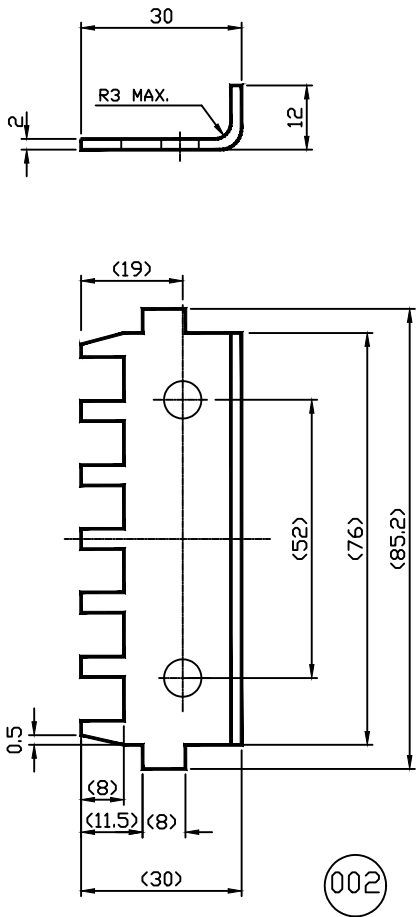

DEVELOPMENT OF ITEM-002

UNSPECIFIED TOLERANCES SHALL BE :-
FOR MACHINING MEDIUM AA0230208.
FOR SHEARING OF SHEETS AS PER AA0230409.

FINISH:-

ZINC PLATE & PASSIVATE TO AA0673603 & AA0673604.
(0.013 TK. MIN.)

REF DRG.-35964011112

-	-	002	2TK. x 38 x 85.2 LG. H.R.C. STEEL SHEET			AA 1011713110			0.052	
VAR 00	REMARKS	VAR NO.	ITEM NO.	DESCRIPTION	STD	DRAWING NO.	IT.NO.	MATERIAL CODE	A UNIT	UNIT WT.
							AA 10113		C	QTY

ADDITIONAL INFORMATION

STATUS OF DRAWING

DISTRIBUTION OF PRINTS

कार्यालय प्रति ---- 1
एस. डब्ल्यू. एम. - 3
टी. सी. एच.एस. ---- 1

TYPE OF PRODUCT OR
NAME OF CUST/PROJ

VM-12 (BT-II)



BHARAT HEAVY ELECTRICALS LIMITED
BHOPAL

DRN	NAME	SIGN	DATE	NO. OF VAR
CKD	G.PRASAD		07.04.01	
APPD	S.S.A.		29.05.01	
	D.BHATT		29.05.01	

REV	DATE	DRN	DEPT	UN. TOL.DIMGR.	SCALE	WEIGHT (KG.)	REF TO ASSY	ITEM NO.	NO. OF ITEMS
		CKD	SWE		1:1		35211001723	004 & 005	002
		APPD	CODE				DRG NO		REV.
			409				3 521 10 01 728		00
							SHT.NO.	02	NO. OF SHT.
									02

SHUTTER

INVENTORY No. 35211001731-R00-S01 REF. DRG. NO. SIGN. & DATE THE INFORMATION ON THIS DOCUMENT IS THE PROPERTY OF BHARAT HEAVY ELECTRICALS LIMITED. IT MUST NOT BE USED DIRECTLY OR INDIRECTLY IN ANY WAY DETRIMENTAL TO THE INTEREST OF THE COMPANY.

3 521 10 01 731
ON DRAWING/DRGAWING NO. 35211001731

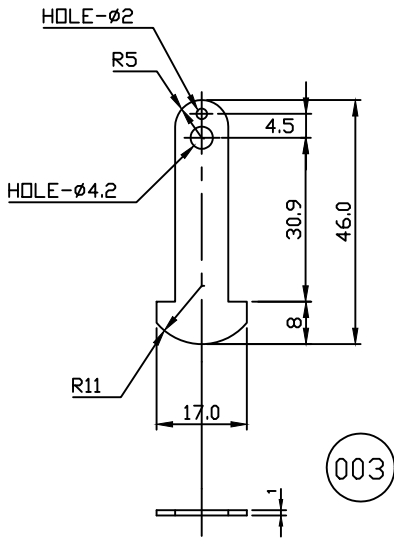
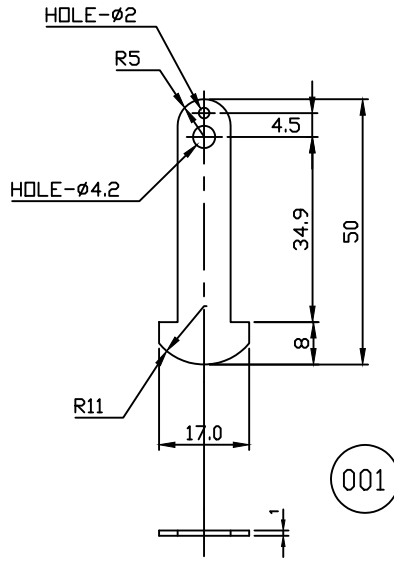
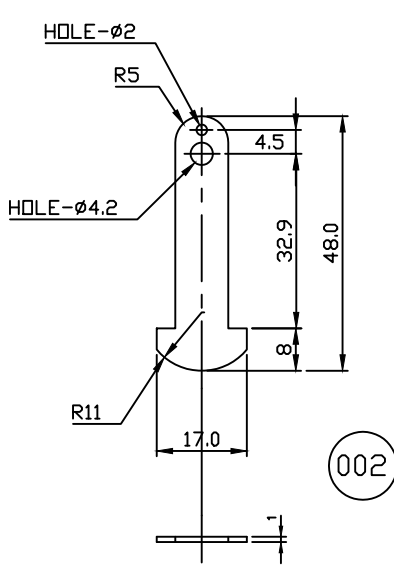

UNSPECIFIED TOLERANCES SHALL BE :-
FOR MACHINING MEDIUM AA0230208.
FOR SHEARING OF SHEETS AS PER AA0230409.

FINISH :-

ZINC PLATE & PASSIVATE TO (0.013TK.MIN.)
PROCESS SPEC. NO. AA0673603 & AA0673604.

NOTES:-

ITEM-001 FOR 20-TK CONNECTOR
ITEM-002 FOR 16-TK CONNECTOR
ITEM-003 FOR 12-TK CONNECTOR

OLD DRG.35964011105

VAR. NO.	REMARKS	VAR. NO.	ITEM NO.	DESCRIPTION	STD.	DRAWING NO.	IT. NO.	MATL. CODE.	A	UNIT	UNIT WT.	GS.
			003	1TKx17x 46 LG CRS SHEET				AA 1011715074			0.004	
								AA 10115			001	
			002	1TKx17x 48 LG CRS SHEET				AA 1011715074			0.004	
								AA 10115			001	
			001	1TKx17x 50 LG CRS STEEL SH.				AA 1011715074			0.004	
								AA 10115			001	
							VAR	MATL. SPCN.	C	UNIT	QTY.	

ADDITIONAL INFORMATION

STATUS OF DRAWING B

DISTRIBUTION OF PRINTS

OFFICE COPY - 1
SWM - 3
TCX -BL. IV - 1

REV	DATE	ALTERED
		CHECKED
		APPROVED

TYPE OF PRODUCT OR

NAME OF CUSTOMER/PROJECT

VM-12(BT-2)



BHARAT HEAVY ELECTRICALS LTD.
BHOPAL

खनक्या DRN.	नाम /NAME	हस्ता/SIGN.	दि./DATE	वेरि की संख्या NO. OF VAR.
	G.PRASAD		07-04-01	
	SSA		29-05-01	
	D.BHATT		29-05-01	

विभाग DEPT. SWE
कोड CODE. 409
अन.टल.नाप की त्रुटि UNTOL. DIMS. GR.
REF CG 06503
अनुपात SCALE 2:1
भारक. ग. WEIGHT (K.G.)

असे. ड्राईंग का संदर्भ REF. TO ASSY.
35211001721
मद संख्या NO. OF ITEM 013 TO 015
मद संख्या NO. OF ITEM 003

/TITLE

SPRING PULL ROD

ड्राईंग क्र./DRGAWING NO. 3 521 10 01 731
पुन./REV. 00
शीट क्र./SHT.NO 01 शीटों की सं./NO.OF.SHT. 01

35219006505 DRG NO

THE INFORMATION ON THIS DOCUMENT IS THE PROPERTY OF BHARAT HEAVY ELECTRICALS LIMITED. IT MUST NOT BE USED DIRECTLY OR INDIRECTLY IN ANY WAY DETRIMENTAL TO THE INTEREST OF THE COMPANY.

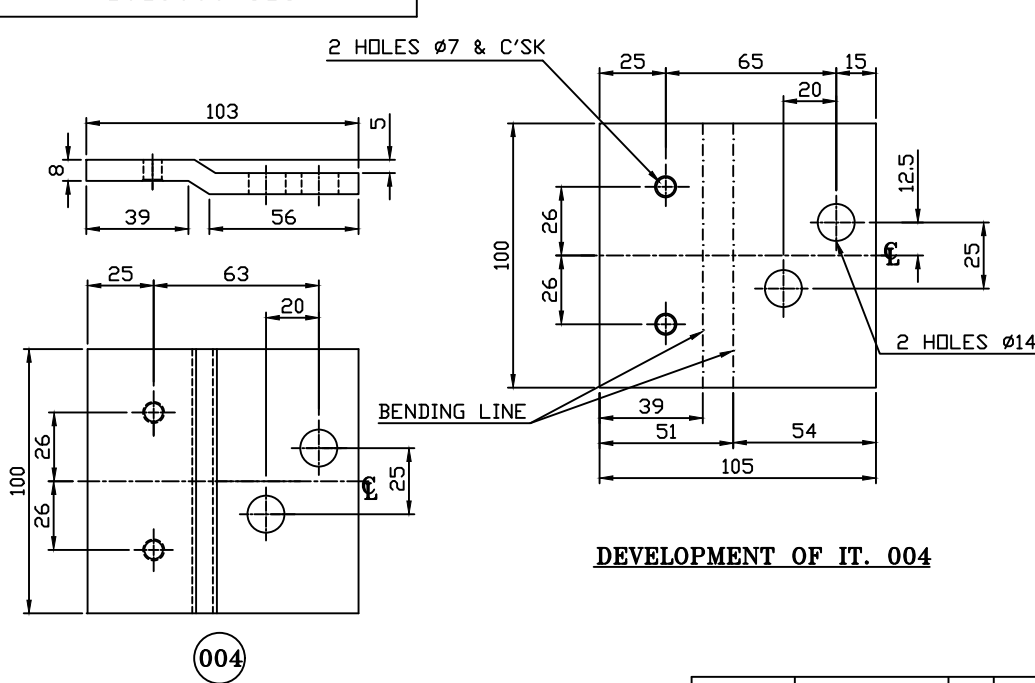

DEVELOPMENT OF IT. 004

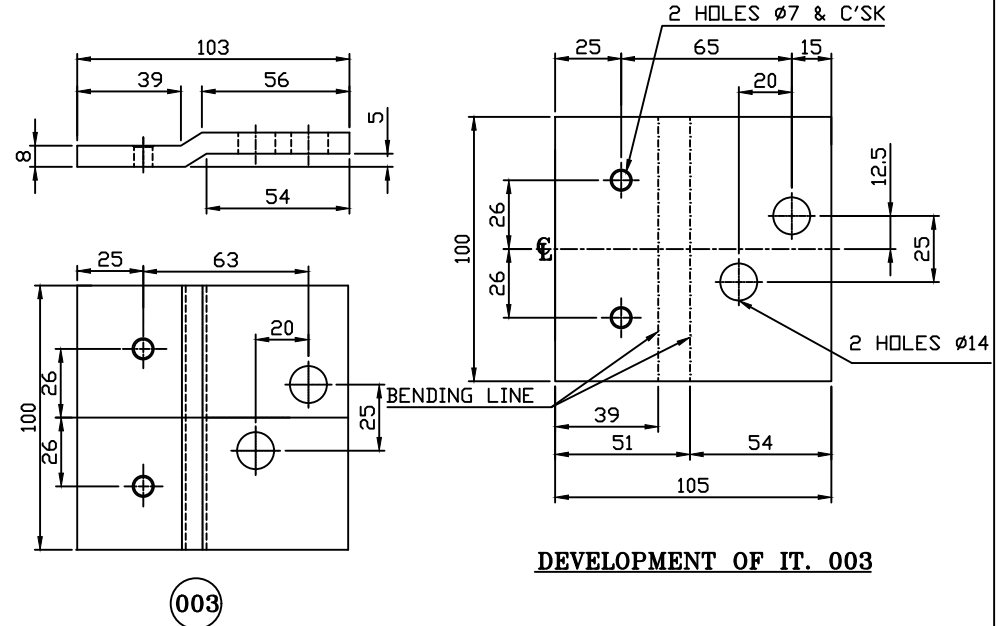

DEVELOPMENT OF IT. 003

UNSPECIFIED TOLERANCES SHALL BE :-

FDR MACHINING AS PER AA0230208
FDR SHEARING AS PER AA0230409

VAR 00	REMARKS	VAR NO.	ITEM NO.	DESCRIPTION	STD	DRAWING NO.	IT.NO.	MATERIAL CODE	A	UNIT	UNIT WT.
							VAR	MATL. SPCN.	C		QTY
			004	8x 100x 105LG. H. HARD CU. FLAT				BP1201905699 AA12005			0.535 001
			003	8x 100x 105LG. H. HARD CU. FLAT				BP1201905699 AA12005			0.535 001
			002	6x 75x 103LG. H. HARD CU. FLAT				BP1201905699 AA12005			0.393 001
			001	6x 75x 103LG. H. HARD CU. FLAT				BP1201905699 AA12005			0.393 001

IMPORTANT NOTES (CTQ)

- A) SILVER PLATING ON COMPLETE SURFACE AREA SHALL BE DONE AS PER SG14610. SILVER PLATING THICKNESS SHALL BE MINIMUM 5 MICRON.
- B) 5% SAMPLE SHALL BE COMPULSORILY CHECKED FOR PLATING THICKNESS AFTER RECEIPT AT BHOPAL WORKS.
- C) ADHESION AND ANTI-TARNISHING SHALL ALSO BE CHECKED.
- D) SUPPLIER LOGO & PO NO. TO BE PUNCHED AT LOCATIONS MARKED ###.STICKER IS NOTACCEPTABLE.

ADDITIONAL INFORMATION

STATUS OF DRAWING

DISTRIBUTION OF PRINTS

कार्यालय प्रति ---- 1
दस. डबल्यू. दम. - 3
टी. सी. दवेस. ---- 1

TYPE OF PRODUCT OR NAME OF CUST/PROJ

VM-12(BT-II)



BHARAT HEAVY ELECTRICALS LIMITED
BHOPAL

DRN	NAME	SIGN	DATE	NO. OF VAR
DRN	P.PARE		21.11.01	
CKD	K.S.MANI		21.11.01	
APPD	D.BHATT		21.11.01	-

REV	DATE	DRN	AKN	REV	DATE	DRN	SUS	DEPT	SWE	UN. TOL.DIMGR.	SCALE	WEIGHT (KG.)	REF TO ASSY	ITEM MD.	NO.OF ITEMS
03	21.03.14	CKD	BPC	02	17.08.07	CKD	SSA	409		-	1:2		-		004
		APPD	HRP			APPD	ANITA								
		IMPORTANT NOTES (CTQ) UPDATED.				DRG. CORRECTED. & REDRAWN		TITLE				CONNECTION			
		(DCA NO. 32465)				(DCA NO. 26949)						DRG NO		REV.	
												35219006505		03	
												SHT.NO.	01	NO.OF SHT.	02

DRG NO 35219006505

THE INFORMATION ON THIS DOCUMENT IS THE PROPERTY OF BHARAT HEAVY ELECTRICALS LIMITED. IT MUST NOT BE USED DIRECTLY OR INDIRECTLY IN ANY WAY DETRIMENTAL TO THE INTEREST OF THE COMPANY.

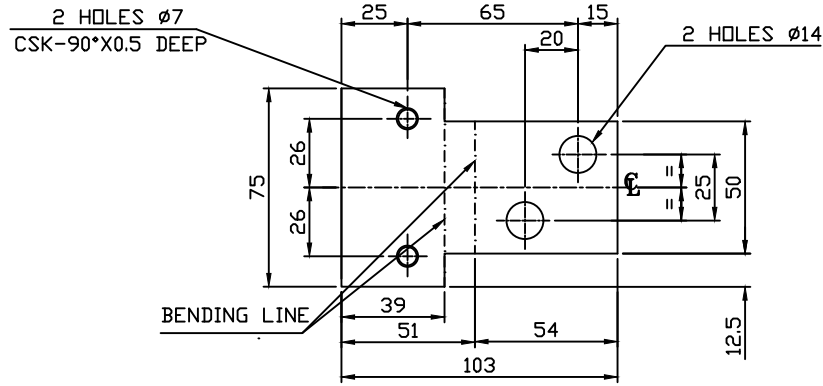

DEVELOPMENT OF IT. 002

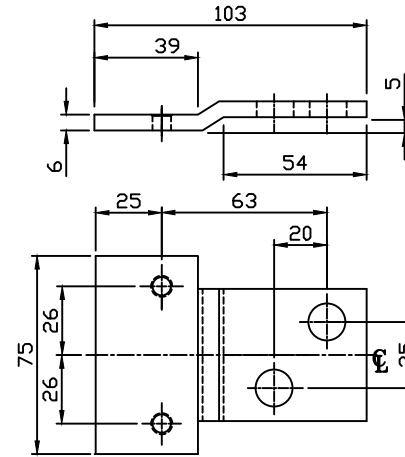

001

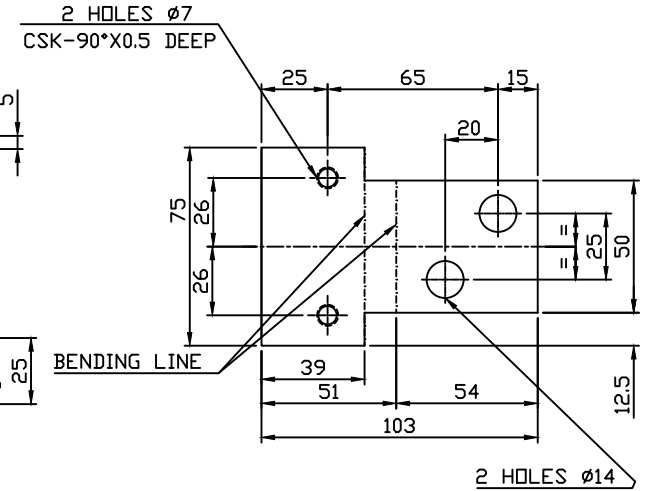

DEVELOPMENT OF IT. 001

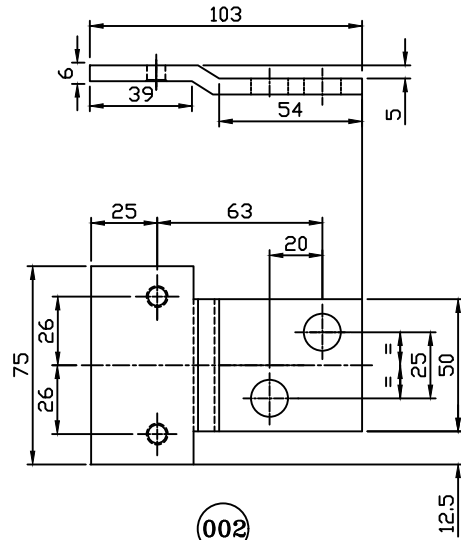

VAR	REMARKS	VAR NO.	ITEM NO.	DESCRIPTION	STD	DRAWING NO.	IT.NO.	MATERIAL CODE	A	UNIT	UNIT WT.
00							VAR	MATL. SPCN.	C		QTY

35219006505-R02-S02
REF.DRG.NO.

SIGN. & DATE

INVENTORY NO.

ADDITIONAL INFORMATION

STATUS OF DRAWING

DISTRIBUTION OF PRINTS

कार्यालय प्रति ---- 1
दस. डब्ल्यू. दम. - 3
टी. सी. दवेस. ---- 1

TYPE OF PRODUCT OR NAME OF CUST/PROJ **VM12(BT-II)**



BHARAT HEAVY ELECTRICALS LIMITED
BHOPAL

DRN	NAME	SIGN	DATE	NO. OF VAR
CKD	P.PARE		21.11.01	
APPD	K.S.MANI		21.11.01	
	D.BHATT		21.11.01	-

REV	DATE	DRN	AKN	REV	DATE	DRN	SUS
03	21.03.14	CKD	BPC	02	17.08.07	CKD	SSA
		APPD	HRP			APPD	ANITA

IMPORTANT NOTES (CTQ) UPDATED. (DCA NO. 32465)

DRG. CORRECTED. & REDRAWN (DCA NO. 26949)

DEPT	UN. TOL.DIMGR.	SCALE	WEIGHT (KG.)	REF TO ASSY	ITEM MD.	NO.OF ITEMS
SWE	-	1:2		-		004
CODE						
409						

TITLE **CONNECTION**

DRG NO	REV.
35219006505	03
SHT.NO.	NO.OF SHT.
02	02

THE INFORMATION ON THIS DOCUMENT IS THE PROPERTY OF BHARAT HEAVY ELECTRICALS LIMITED. IT MUST NOT BE USED DIRECTLY OR INDIRECTLY IN ANY WAY DETRIMENTAL TO THE INTEREST OF THE COMPANY.

REV.	DATE	ALTERED	REV.	DATE	ALTERED	ADDITIONAL INFORMATION
		CHECKED	01		CHECKED	STATUS OF DRAWING
DRG.REDRAWN. VIEW ADDED FOR EACH ITEMS (DCA.....)						DISTRIBUTION OF PRINTS
						□/C-1 SWM-3 TCX-1

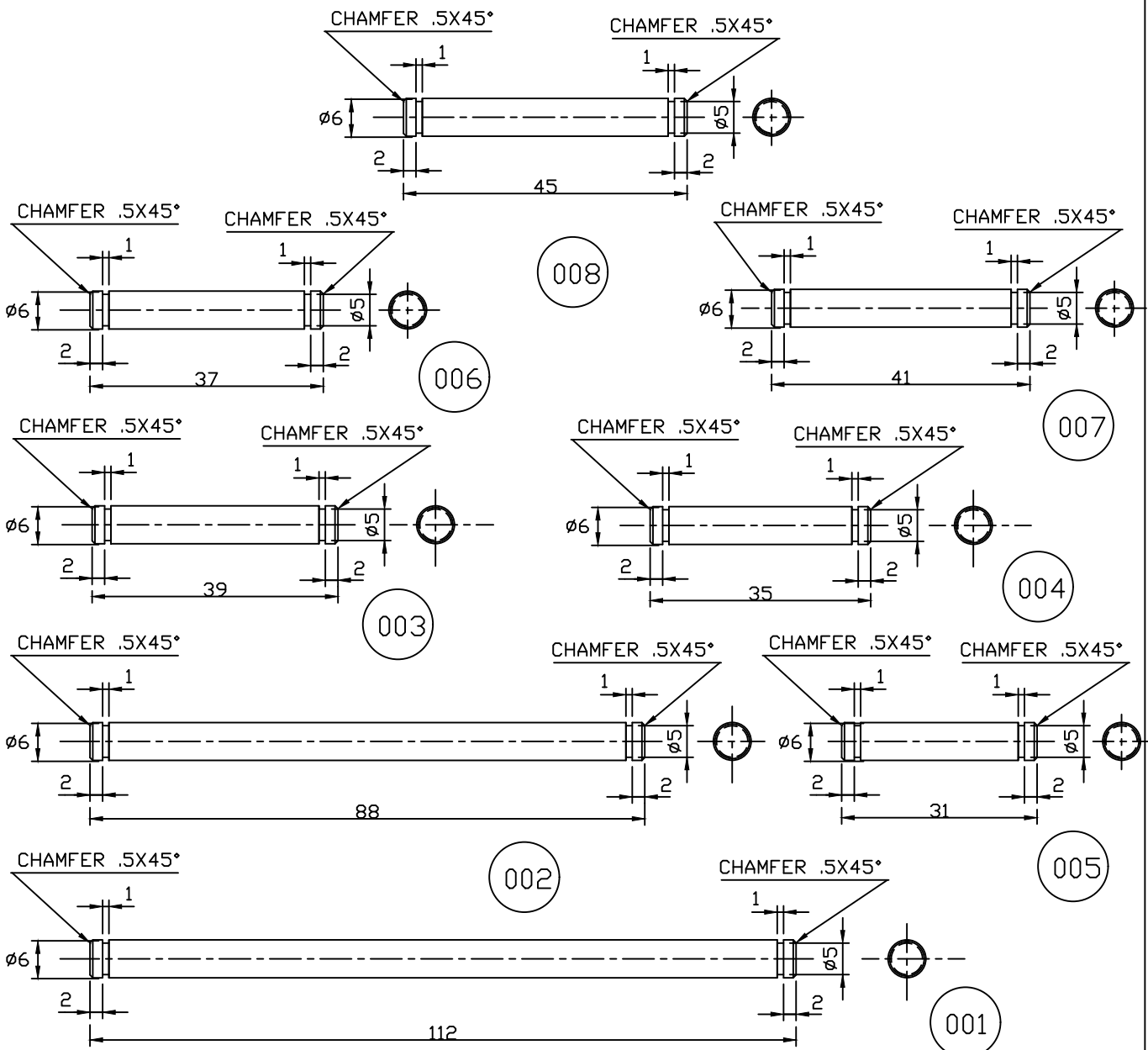

FOR B.O.M. REF SHEET NO. 02

INVENTORY No. 45211001727-R01-S01
SIGN & DATE
REF. DRG. No.

REMARKS	ITEM NO.	DESCRIPTION	STD.	MATL. CODE	A	UNITS	UNIT WT.
				MATL. SPECN	C		QTY.

 BHATAT HEAVY ELECTRICALS LIMITED BHOPAL	NAME	SIGN.	DATE	NO. OF VAR		
	DRN	G.PRASAD	07.04.01			
	CHD	S.S.A.	29.05.01			
	APPD	D.BHATT	29.05.01			
DEPT. SWE	UN. TOL.DIM.GR.	SCALE	WEIGHT (Kg.)	REF. TO ASSY. DRG.	ITEM NO. 010 & 011	NO. OF ITEMS
CODE 409		1:1		35211001721		008
TITLE				DRAWING No.	REV.	
GROOVE PIN				4 521 1 00 1727	01	
				SHEET NO. 01	NO. OF SHEETS 02	

REV.	DATE	ALTERED	REV.	DATE	ALTERED	ADDITIONAL INFORMATION
		CHECKED		01		
			DRG.REDRAWN. VIEW ADDED FOR EACH ITEMS (DCA.NO.22581)			STATUS OF DRAWING
						DISTRIBUTION OF PRINTS □/C-1 SWM-3 TCX-1

THE INFORMATION ON THIS DOCUMENT IS THE PROPERTY OF BHARAT HEAVY ELECTRICALS LIMITED. IT MUST NOT BE USED DIRECTLY OR INDIRECTLY IN ANY WAY DETRIMENTAL TO THE INTEREST OF THE COMPANY.

UNSPECIFIED TOLERANCES SHALL BE :-
 FOR MACHINING MEDIUM AA0230208.
 FOR SHEARING OF SHEETS AS PER AA0230409.
FINISH :-
 ZINC PLATE & PASSIVATE TO AA0673603 AND
 AA0673604 (0.013 TK. MIN.)

45211001727-R01-S01
REF. DRG. No.

REMARKS	ITEM NO.	DESCRIPTION	STD.	MATL. CODE	A - C	UNITS	UNIT WT.
				MATL. SPECN			QTY.
	008	6 DIAX45 LG BRT STEEL BARS		BP 1010272020 BP 10172			0.009 001
	007	6 DIAX41 LG BRT STEEL BARS		BP 1010272020 BP 10172			0.008 001
	006	6 DIAX37 LG BRT STEEL BARS		BP 1010272020 BP 10172			0.008 001
	005	6 DIAX31 LG BRT STEEL BARS		BP 1010272020 BP 10172			0.006 001
	004	6 DIAX35 LG BRT STEEL BARS		BP 1010272020 BP 10172			0.007 001
	003	6 DIAX39 LG BRT STEEL BARS		BP 1010272020 BP 10172			0.008 001
	002	6 DIAX88 LG BRT STEEL BARS		BP 1010272020 BP 10172			0.018 001
	001	6 DIAX112 LG BRT STEEL BARS		BP 1010272020 BP 10172			0.023 001

SIGN & DATE
INVENTORY No.

	BHARAT HEAVY ELECTRICALS LIMITED BHOPAL		DRN	G.PRASAD	SIGN.	07.04.01	NO.OF VAR
			CHD	S.S.A.		29.05.01	
			APPD	D.BHATT		29.05.01	
DEPT. SWE CODE 409	UN. TOL.DIM.GR.	SCALE 1:1	WEIGHT (Kg.)	REF. TO ASSY. DRG. 35211001721	ITEM MD. 010 & 011	NO.OF ITEMS 008	
TITLE GROOVE PIN				DRAWING No. 4 521 1 00 1727		REV. 01	
				SHEET NO. 02		NO.OF SHEETS 02	

REV.	DATE	ALTERED	MKN	REV.	DATE	ALTERED	ADDITIONAL INFORMATION
01	20.09.13	CHECKED	AKHIL			CHECKED	STATUS OF DRAWING
DIM. 20, 8.2 & 0.5X45° WERE DIM. 15, 5.7 & 0.3X45° RESPECTIVELY. (DCA. NO.32119)							DISTRIBUTION □/C-1 SWM-3 OF PRINTS TCX-1

THE INFORMATION ON THIS DOCUMENT IS THE PROPERTY OF BHARAT HEAVY ELECTRICALS LIMITED.
 IT MUST NOT BE USED DIRECTLY OR INDIRECTLY IN ANY WAY DETRIMENTAL TO THE INTEREST OF THE COMPANY.

UNSPECIFIED TOLERANCES SHALL BE :-
 FOR MACHINING MEDIUM AA0230208,
 FOR SHEARING OF SHEETS AS PER AA0230409.

FINISH :-

ZINC PLATE & PASSIVATE TO AA0673603 AND
 AA0673604 (0.013 TK. MIN.)

OLD DRG.-45964011101

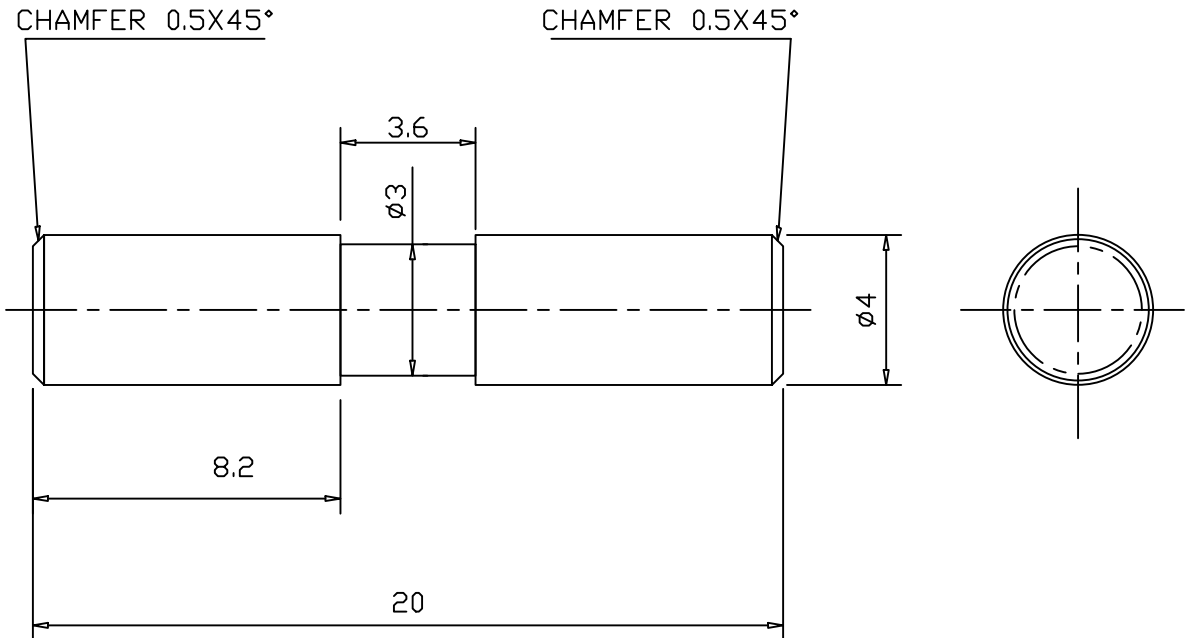

45211001728-R01-S01
 REF. DRG. No.

SIGN & DATE
 INVENTORY No.

REMARKS	ITEM NO.	DESCRIPTION	STD.	MATL. CODE	A - C	UNITS	UNIT WT.
	001	5∅x22LG. BRIGHT STEEL BAR		AA1010212010			0.002
				AA10112			001
				MATL. SPECN			QTY.



BHATAT HEAVY ELECTRICALS LIMITED
 BHOPAL

DRN	NAME	SIGN.	DATE	NO. OF VAR
CHD	G.PRASAD		07.04.01	
APPD	S.S.A.		29.05.01	
	D.BHATT		21.12.98	

DEPT. SWE	UN. TOL. DIM. GR.	SCALE	WEIGHT (Kg.)	REF. TO ASSY. DRG.	ITEM NO.	NO. OF ITEMS
CODE 409		10:1		35211001721	019	001
TITLE				DRAWING No.	REV.	
PIN				4 521 10 01728	01	
				SHEET NO. 01	NO. OF SHEETS 01	

THE INFORMATION ON THIS DOCUMENT IS THE PROPERTY OF BHARAT HEAVY ELECTRICALS LIMITED. IT MUST NOT BE USED DIRECTLY OR INDIRECTLY IN ANY WAY DETRIMENTAL TO THE INTEREST OF THE COMPANY.

REV.	DATE	ALTERED	REV.	DATE	ALTERED	ADDITIONAL INFORMATION
		CHECKED			CHECKED	
						STATUS OF DRAWING
						DISTRIBUTION OF PRINTS

□/C-1 SWM-3
TCX-1



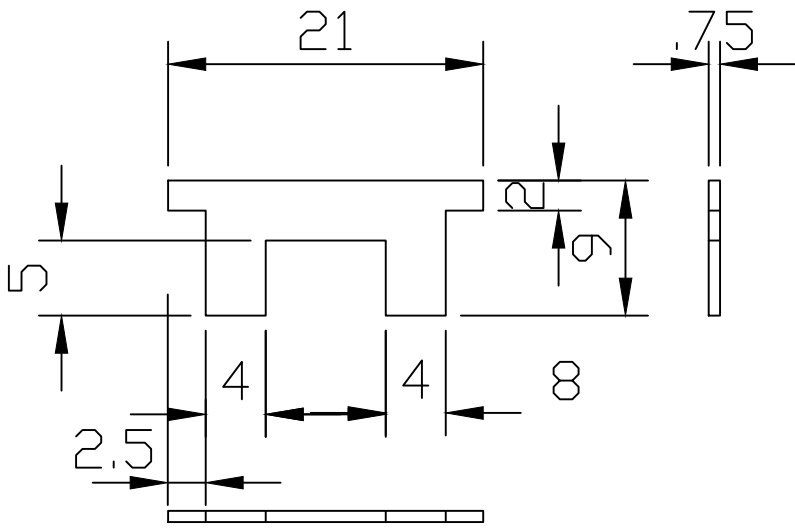

UNSPECIFIED TOLERANCES SHALL BE :-
 FOR MACHINING MEDIUM AA0230208.
 FOR SHEARING OF SHEETS AS PER AA0230409.
FINISH :-
 ZINC PLATE & PASSIVATE TO AA0673603 AND AA0673604 (0.013 TK. MIN.)
 OLD DRG.-35964011104



45211001729-R00-S01
REF. DRG. No.

REMARKS	ITEM NO.	DESCRIPTION	STD.	MATL. CODE	A - C	UNITS	UNIT WT.
	001	0.75TK.x9x21 LG. CR.C.S.SHEET		BP 1011715988			0.001
				AA 10115			001
				MATL. SPECN			QTY.

SIGN & DATE
INVENTORY No.

 BHARAT HEAVY ELECTRICALS LIMITED BHOPAL	DRN	NAME	SIGN.	DATE	NO. OF VAR	
	CHD	G.PRASAD		07.04.01		
	APPD	S.S.A.		29.05.01		
		D.BHATT		29.05.01		
DEPT. SWE	UN. TOL.DIM.GR.	SCALE	WEIGHT (Kg.)	REF. TO ASSY. DRG.	ITEM NO.	NO. OF ITEMS
CODE 409		2:1		35211001721	007	001
TITLE				DRAWING No.	REV.	
COTTER PIN				4 521 1001729	00	
				SHEET NO. 01	NO. OF SHEETS	01