

SUBJECT	BID SPECIFIC ATC - 20232761
----------------	------------------------------------

1.	BHEL Contact (Technical/Commercial):
	For any technical/commercial clarification , please contact Mr. Sandeep, Manager (PPX-TL). e-mail: kumar.sandeep@bhel.in and Mr. Manoj Gaurav , Sr. Manager (PPX-TL) Contact No. 01334-28-5182, e-mail : mgaurav@bhel.in
2.	Acceptance of Offer:
	Bidder's offer shall be considered for evaluation based on Technical and other commercial documents submitted along with bid. Bidder's offer shall be acceptable subject to final acceptance of offer by Indenter. Price bid of those bidders shall be opened whose offer is techno-commercially is acceptable to BHEL (HEEP) Haridwar as per drawing/Specification. Note 01: PO No. &/OR Vendor's emblem/seal shall be clearly punch marked/ETCHED on each item. Note 02: The material is required for SUB/SUPER CRITICAL Projects.
3.	Splitting of Quantities:
	Quantity of splitting shall be as per GeM (NIT)
4.	Inspection and Test Reports/Certificate
	Third Party Inspection is required. Bidders is to submit the material test certificate.
5.	Terms of Delivery:
	Delivery period shall be as per GeM. However, early delivery is also acceptable.
6.	Deviations:
	a) Technical Deviation: No Technical Deviation is envisaged. b) Commercial Deviation: No Commercial Deviation is envisaged. Item are required as per item description/specification mentioned against item. In case of any deviation offer shall be rejected.
7.	Terms of Payment:
	"For Non MSEs bidder: 100% of payment along with taxes, freight & insurance shall be made after receipt and acceptance of material and within 90 days from the date of invoice subject to submission of non-discrepant documents within 15 days of supply as per terms and conditions of Purchase Order. For Medium Enterprises bidder: 100% of payment along with taxes, freight & insurance shall be made after receipt and acceptance of material and within 60 days from the date of invoice subject to submission of non-discrepant documents within 15 days of supply as per terms and conditions of Purchase Order. For MSEs bidder: For MSEs (covered under MSME Act) which are registered and periodically renewed with BHEL, the payment shall be made within 45 days or as prescribed in the relevant act. Benefits of MSE (such as EMD Waiver, Tender fee exemption, Price preference, Payment preference etc.) will be given only to those MSE Vendors who are manufacturers of offered items against the NIT. MSE benefits shall not be provided to Agents / Stockists / Dealers / Traders etc. for the offered items if not manufactured by themselves."

SUBJECT	BID SPECIFIC ATC - 20232761
----------------	------------------------------------

	<p>Note 01:</p> <ul style="list-style-type: none"> • Bills shall be submitted to BHEL HEEP Haridwar office for processing along with billing checklist. • It should be ensured that Tax Invoice complies with statutory requirements under GST law to enable BHEL to avail Input Tax Credit. • Payment of GST component shall be made only if vendor has deposited the Tax and credit for the same is reflected in GSTN (GST Network). • Copy of GST Registration Certificate(s) shall be also be attached with Tax Invoice.
8.	<p>Prices:</p> <p>The quoted prices shall be on Firm basis. Price to be quoted as inclusive of GST, i.e., Ex-works including Packing & Forwarding Charges + F&I + GST.</p>
9.	<p>Reverse Auction:</p> <p>Bid to RA is applicable.</p>
10.	<p>Liquidated Damage for delayed Delivery:</p> <p>If the Seller/Service Provider fails to deliver any or all of the Goods/Services within the original/re-fixed delivery period(s) specified in the contract, the Buyer will be entitled to deduct/recover the Liquidated Damages for the delay, unless covered under Force Majeure conditions aforesaid, @ 0.5% of the contract value of delayed quantity per week or part of the week of delayed period as pre-estimated damages not exceeding 10% of the contract value of delayed quantity without any controversy/dispute of any sort whatsoever.</p>
11.	<p>Unpriced Bid:</p> <p>Vendor to furnish unpriced bid mentioning "Quoted" against each BOQ line item and % of GST quoted in tender as per Annexure-I.</p>
12.	<p>Details of Bidder:</p> <p>Bidder to submit their complete contact information details as per Annexure-II.</p>
13.	<p>Make in India:</p> <p>Not Applicable</p>
14.	<p>Evaluation Criteria:</p> <p>Evaluation shall be done on item wise.</p>
15.	<p>Conflict of Interest:</p> <p>"A bidder shall not have conflict of interest with other bidders. Such conflict of interest can lead to anti-competitive practices to the detriment of Procuring Entity's interests. The bidder found to have a conflict of interest shall be disqualified. A bidder may be considered to have a conflict of interest with one or more parties in this bidding process, if:</p> <ul style="list-style-type: none"> i) they have controlling partner (s) in common; <li style="text-align: center;">or ii) they receive or have received any direct or indirect subsidy/ financial stake from any of them; <li style="text-align: center;">or iii) they have the same legal representative/agent for purposes of this bid; <li style="text-align: center;">or

- iv) they have relationship with each other, directly or through common third parties, that puts them in a position to have access to information about or influence on the bid of another Bidder;

or

- v) Bidder participates in more than one bid in this bidding process. Participation by a Bidder in more than one Bid will result in the disqualification of all bids in which the parties are involved. However, this does not limit the inclusion of the components/ sub-assembly/ Assemblies from. one bidding manufacturer in more than one bid;

or

- vi) In cases of agents quoting in offshore procurements, on behalf of their principal manufacturers, one agent cannot represent two manufacturers or quote on their behalf in a particular tender enquiry. One manufacturer can also authorize only one agent/dealer. There can be only one bid from the following:
 - 1. The principal manufacturer directly or through one Indian agent on his behalf; and
 - 2. Indian/foreign agent on behalf of only one principal;

or

- vii) A Bidder or any of its affiliates participated as a consultant in the preparation of the design or technical specifications of the contract that is the subject of the Bid;

or

- viii) In case of a holding company having more than one independently manufacturing units, or more than one unit having common business ownership/management, only one unit should quote. Similar restrictions would apply to closely related sister companies. Bidders must proactively declare such sister/ common business/ management units in same/ similar line of business".

16. Risk Purchase:

In case of abnormal delays (beyond the maximum late delivery period as per LD clause) in supplies / defective supplies or non-fulfillment of any other terms and conditions given in Purchase Order, BHEL may cancel the Purchase Order in full or part thereof, and may also make the purchase of such material from elsewhere / alternative source at the risk and cost of the supplier. BHEL will take all reasonable steps to get the material from alternate source at optimum cost. If bidder does not agree to the above Risk Purchase Clause, BHEL reserves the right to reject the offer. In case for compelling reasons BHEL accepts the offer without acceptance of this clause by the bidder and in the eventuality of Risk Purchase, appropriate action will be taken as per BHEL extant rules. This will be without prejudice to any other right of BHEL under the contract or under General Law.

Action against Bidders / vendor / supplier / contractor in case of default:

In order to protect the commercial interests of BHEL, BHEL shall take action against supplies / contractors by way of suspension of business dealings, who either fail to perform or are in default without any reasonable cause, cause loss of business/ money/ reputation, indulge in malpractices, cheating, bribery, fraud or any other misconduct or formation of cartels so as to influence the bidding process or influence the price etc.

Suspension of Business Dealings could be in the form of "Hold" or "Banning" a supplier/ contractor or a bidder and shall be as per "Guidelines for Suspension of Business Dealings with Suppliers/ Contractors" available at BHEL's website "<https://www.bhel.com/guidelines-suspension-business-dealings-supplierscontractors>

"The offers of the bidders who are under suspension as also the offers of the bidders, who engage the services of the firms debarred across BHEL, shall be rejected. The list of firms debarred across BHEL is available on BHEL web site www.bhel.com.

1.0 Integrity commitment, performance of the contract and punitive action thereof:

1.1. Commitment by BHEL: BHEL commits to take all measures necessary to prevent corruption in connection with the tender process and execution of the contract.

BHEL will during the tender process treat all Bidder(s) in a transparent and fair manner, and with equity.

1.2. Commitment by Bidder/ Supplier/ Contractor:

SUBJECT	BID SPECIFIC ATC - 20232761
----------------	------------------------------------

	<p>1.2.1. The bidder/ supplier/ contractor commits to take all measures to prevent corruption and will not directly or indirectly influence any decision or benefit which he is not legally entitled to nor will act or omit in any manner which tantamount to an offence punishable under any provision of the Indian Penal Code, 1860 or any other law in force in India.</p> <p>1.2.2. The bidder/ supplier/ contractor will, when presenting his bid, disclose any and all payments he has made, and is committed to or intends to make to agents, brokers or any other intermediaries in connection with the award of the contract and shall adhere to relevant guidelines issued from time to time by Govt. of India/ BHEL.</p> <p>1.2.3. The bidder/ supplier/ contractor will perform/ execute the contract as per the contract terms & conditions and will not default without any reasonable cause, which causes loss of business/ money/ reputation, to BHEL.</p> <p>If any bidder/ supplier/ contractor during pre-tendering/ tendering/ post tendering/ award/ execution/ post-execution stage indulges in malpractices, cheating, bribery, fraud or and other misconduct or formation of cartel so as to influence the bidding process or influence the price or acts or omits in any manner which tantamount to an offence punishable under any provision of the Indian Penal Code, 1860 or any other law in force in India, then, action may be taken against such bidder/ supplier/ contractor as per extant guidelines of the company available on www. bhel.com and/or under applicable legal provisions”.</p>
17.	RXIL (TReDS) Platform:
	BHEL is registered with RXIL (TReDS) platform. MSME bidders are requested to get registered with RXIL (TReDS) platform to avail the facility as per Gol guidelines.
18.	<p>Bidder to submit sealed and signed copy of the following while uploading bid in GeM portal:</p> <p>a) Bid Specific ATC: This document.</p> <p>b) Annexure-I: Unpriced Bid</p> <p>c) Annexure-II: Contact Details of Bidder</p> <p>d) Annexure-III: Local Content Self-Certification</p> <p>e) Annexure-IV: Schedule of Commercial Deviation</p> <p>f) Annexure-V: Schedule of Technical Deviation</p> <p>g) Annexure-VI: PRE-QUALIFYING CONDITIONS</p> <p>Note: In case of non-receipt of above documents, the bidder is liable for rejection.</p>
19.	All other terms & conditions shall be as per GTC of GeM.

Signature of the authorized representative of

Place :
Date :

Bidder's Name :
Designation :
Company Seal :

SUBJECT	BID SPECIFIC ATC - 20232761
----------------	------------------------------------

ANNEXURE-I

UNPRICED BID

Sl. No.	Item Description	Unit	Quantity	Item	GST
1.	AAA703977423 CENTRE PIN FOR TAIL STOCK DRG.NO.- R7039-7742 REV.-03	NO	100	Quoted (Inclusive of GST and Freight & Insurance)	18%
2.	AAA703977458 CENTER PIN 1 FOR DOUBLE SPINDLE 5 AXIS LIECHTI MACHINE DRG.NO.-R7039-7745 REV.-02	NO	100	Quoted (Inclusive of GST and Freight & Insurance)	18%

Signature of the authorized representative of

Place :

Date :

Bidder's Name :

Designation :

Company Seal :

SUBJECT	BID SPECIFIC ATC - 20232761
----------------	------------------------------------

ANNEXURE-II

CONTACT DETAILS OF BIDDER

Work Address	
Correspondence Address	
PAN NO.	
GST No.	
Details of contact person for clarification regarding bid:	
Contact Person Name	
Designation	
email ID	
Mobile No.	
Landline No.	

Signature of the authorized representative of

Place :
Date :

Bidder's Name :
Designation :
Company Seal :

Self-certification as per Government Public procurement order no. P-45021/2/2017-BE-II dt.15.06.2017 & P-45021/2/2017-PP(BE-II) dated 28.05.2018,29.5.2019 & 04.6.2020, it is hereby certifying that we

.....
(supplier name) are(Class-I/Class-II) local supplier and will meet the requirement of minimum local content of (50%/20%) as defined in public procurement order dated 04.6.2020 for material against Enquiry no.

..... Details of location at which local value addition will be made is as follows: -

.....
We also understand, false declarations will be in breach of the code of integrity under Rule 175(1) (i) (h) of the General Financial Rules for which a bidder or its successors can be debarred for up to two years as per Rule 151 (iii) of the general financial rules along with such other actions as may be permissible under law. Seal & Signature of Supplier

Seal & Signature of Supplier

SCHEDULE OF COMMERCIAL DEVIATION

The following are the deviations/ variations exception from the General Terms and Conditions:

Sl. No.	Clause No. of Terms and Conditions	Statement of Deviation
	Nil Deviation	Nil Deviation

In case, this schedule is not submitted, it will be presumed that the equipment/ material to be supplied under this contract is deemed to be in compliance with the latest General Terms and Conditions of GeM & Bid specific ATC.

If there is **Nil Deviation**, even then the format to be filled as **Nil Deviation**.

Note:

1. Continuation sheets of like size and format may be used as per the Bidder's Requirement and shall be annexed to this schedule.
2. Deviation mentioned in this schedule shall only be considered.

Signature of the authorized representative of

Place :
Date :

Bidder's Name :
Designation :
Company Seal :

SCHEDULE OF TECHNICAL DEVIATION

The following are the deviations/ variations exception from the Technical Specifications:

Sl. No.	Clause No. of Technical Specifications	Statement of Deviation
	Nil Deviation	Nil Deviation

In case, this schedule is not submitted, it will be presumed that the equipment/ material to be supplied under this contract is deemed to be in compliance with the Technical Specifications.

If there is **Nil Deviation**, even then the format to be filled as **Nil Deviation**.

Note:

- Continuation sheets of like size and format may be used as per the Bidder's Requirement and shall be annexed to this schedule.
- Deviation mentioned in this schedule shall only be considered.

Signature of the authorized representative of

Place :

Date :

Bidder's Name :

Designation :

Company Seal :

Indent No 20232761			
01.00	PRE QUALIFYING CONDITIONS	REQUIRED	VENDOR'S REMARK
01.01	<p>a). Only those vendors to quote who have experience in machining of mechanical fixtures shall quote. (Authorized channel partner/associates of above OEMs may also quote on their behalf. In such case, valid Authorization Certificate issued by OEM on their letter head is to be furnished with the offer)</p> <p>b.) Vendors to provide satisfactory documentary proof w.r.t experience as mentioned in point 01.01.a) This is required from all the vendors for qualification of their offer.</p>	Vendor to accept/agree and provide details	
01.02	Vendor to provide name, designation and contact details (phone number, email address etc.) of the customer for whom such items at Sl. No01.01.a) are supplied.	Vendor to accept/agree and provide details	
01.03	BHEL reserves the right to verify the information provided by vendor. In case the information provided by vendor is found to be false/ incorrect, their offers shall be rejected.	Vendor to accept/agree	
02.00	TECHNICAL SPECIFICATIONS	REQUIRED	
02.01	Vendors to confirm that the items quoted shall be as per BHEL drawing only.	Vendor to confirm	

 राजेश कुमार
 अभियन्ता (दूर सूत्र)
 श्री.एच.ई.एल.सीए, हरिद्वार

DRAWING NO. R7039-7742

1.6 / THE REST

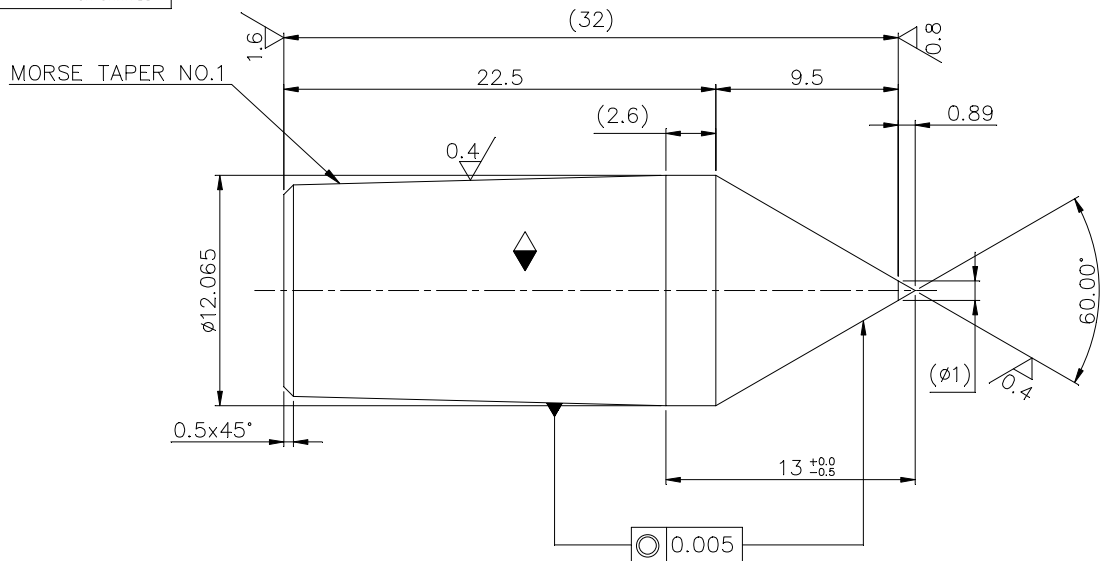

MARK
R7039-7742

DRG. SUPERSEDES THE OLD DRG.

- SHARP EDGES TO BE ROUNDED OFF.
- CONSERVATION TO BE DONE AS PER TL 30007.

VAR.00	REMARKS	ITEM NO.	DESCRIPTION	STD	DRAWING NO.	CARBIDE GRADE-GT20	MAT.CODE	A	UNIT	UNIT WEIGHT	QTY.
--------	---------	----------	-------------	-----	-------------	--------------------	----------	---	------	-------------	------

C.B.O.M.			STATUS OF DRG. U		TYPE OF PRODUCT 500 MW		COMP.DRG.No. 01010236000		M/c No.		REF.DRG.No.	
AGREED DEPTT.	NAME	SIGN.	DATE	W/O No. BAF-135		M/c MODEL No. 3-82		PHOTO GIVEN BY T.B.M.				
T.B.M.	V.K.SINGH	-Sd-	26.07.11	BHARAT HEAVY ELECTRICALS LIMITED, RANIPUR, HARDWAR		DRN. SANDEEP		SIGN -Sd-		DATE 26.07.11		No. of Var.
WELDING-CLASS 'B' OF AA0621104				APPD ANKUR		SIGN -Sd-		DATE 26.07.11				
GAS CUTTING-TABLE 3 OF AA0621101												
REV.	DATE	ALTERED BY	REV.	DATE	ALTERED BY	DEPTT. JTE	SCALE	WEIGHT (KG)	REFER TO ASSLY. DRG.		ITEM NO.	NO. OF ITEMS
		CHD	03	4.07.18	SJTEGS SJTERS	CODE 209	NTS	~0.025	DRAWING NO. R7039-7742			
DRG. SUPERSEDES THE OLD DRG. AS PER CAF NO. JTE-18-F0039						TITLE		CARD CODE		22 23 24		
						CENTRE PIN FOR TAIL STOCK				Sheets No. 01 No. of Sheets 01		

GRADE OF UNTOL. DIM		
M/CG.-AA0230208	X/C/M/F	
GAS CUTTING-TABLE 3 OF AA0621101		
REV.	DATE	ALTERED BY
		CHD

COPYRIGHT AND CONFIDENTIAL THE INFORMATION ON THIS DOCUMENT IS THE PROPERTY OF BHARAT HEAVY ELECTRICALS LIMITED. IT MUST NOT BE USED DIRECTLY OR INDIRECTLY IN ANY WAY DETERIMENTAL TO THE INTEREST OF THE COMPANY.

REFERENCE DRG. NO.

SIGN & DATE

INVENTORY NO. E

COPYRIGHT AND CONFIDENTIAL
THE INFORMATION ON THIS DOCUMENT IS THE PROPERTY OF BHARAT
HEAVY ELECTRICALS LIMITED IT MUST NOT BE USED DIRECTLY
OR INDIRECTLY IN ANY WAY DETRIMENTAL TO THE INTEREST OF COMPANY.

DRAWING No. R7039-7745

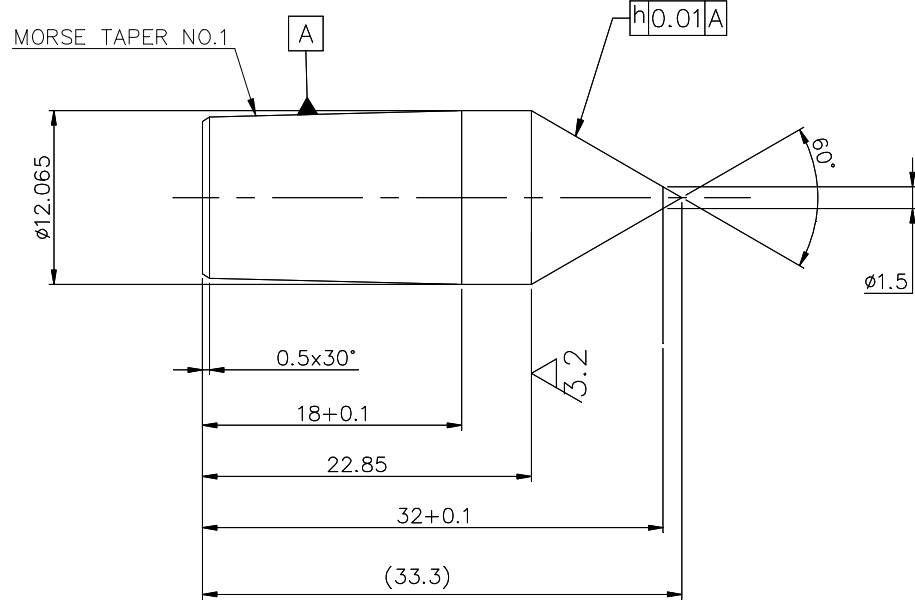

0.8 / THE REST

MARK
R7039-7745

DRG. SUPERSEDES THE OLD DRG.

1. CONSERVATION TO BE DONE AS PER TL 30007

VAR.00	REMARKS	ITEM No.	DESCRIPTION	STD	DRAWING No.	CARBIDE	GRADE-GT20	MATERIAL CODE	A	UNIT	UNIT WEIGHT	QTY.
									c			

GMS No./GR.SP.No.				STATUS OF DRG.	TYPE OF PRODUCT	COMP. DRG. No.	M/C TOOL TRANS No.	REF. DRG. No.				
AGREED DEPT.				NAME	SIGN.	DATE	500MW	21020236004	3-068	SKETCH GIVEN		
TBM				VARUN	-sd-	28.9.11	DESIGN ORDER No.	M/C MODEL No.	KBF-8042	LIECHTI M/C		
GRADE OF UNTOL. DIM.: -				BHARAT HEAVY ELECTRICALS LTD.				DRN	NAME	SIGN.	DATE	No. OF VAR.
M/CG-ℓ/M/ℓ AA0230208				BHEL				CHD	VIPIN	-sd-	28.09.11	
WELDING-A/B/C/D AA0621104				HARDWAR				APD	RAVI	-sd-	28.09.11	
GAS CUTTING-'T3' AA0621101									ANKUR	-sd-	28.09.11	
REV	DATE	ALTERED	REV	DATE	ALTERED	SJTEGS	DEPT. JTE	SCALE	WEIGHT(Kg)	REF.TO ASSY. DRG.	ITEM No.	No. OF ITEMS
		CHECKED	02	14.07.18	CHECKED	SJTERS	CODE 209	NTS	0.03			
				DRG. SUPERSEDES THE OLD DRG. AS PER CAF No. JTE-18-F0038				TITLE		DRAWING No. R7039-7745		
								CENTER PIN 1 FOR DOUBLE SPINDLE 5 AXIS LIECHTI MACHINE		SHEET No. 01 / No. OF SHEETS 01		