

### 3 SPECIFICATIONS

#### 3.1 Standard Machine Specifications

<b>Model</b>	<b>RX7/GX7</b>				
CNC System	ANCA 5DX				
Processor	Pentium 4 or higher 2.6GHz				
Memory	512Mb	Or higher			
Hard Disk	40 Gbyte	Or higher			
DVD-R/CD-RW	52x Speed				
Display	15" LCD				
Touch Screen					
Modem	56K BPS				
RS232	2 Channels				
Parallel	1 Channel				
Expansion	8 USB ports				
	3 PCI Slots				
	Sercos				
	1 AGP				
Working Range	Hard Axes				
	X-axis	Y-axis	Z-axis	A-axis	C-axis
Pitch	10mm	10mm	5mm	360deg	360deg
Travel	439mm	464mm	274mm		307deg
Position Feedback Resolution	0.0001mm	0.0001mm	0.0001mm	0.0001deg	0.0001deg
Programming Resolution	0.001mm	0.001mm	0.001mm	0.001deg	0.001deg
Maximum Feedrate	18m/min	18m/min	9m/min	600 RPM	36000deg/min
Lube System	Auto	Auto	Auto		
Drive System	Sercos Digital closed loop ANCA Digital Drives				
			Soft Axes		
	B-axis	U-axis	V-axis	W-axis	A`-axis
Programming Resolution	0.001deg	0.001mm	0.001mm	0.001mm	0.001deg
Drive System	Software driven				

Workhead				
Workpiece Taper	ISO 50 Pull stud retention ready			
Speed Range	0-600rpm			9.4"
Max Swing	220mm			44lbs
Max Part Weight	20Kg			
Sealing	Continuous Air Purge			
Cooling	Water Cooled			
Chuck System				
Capacity (tool size)	1 - 40mm			
System Type	Pneumatic Precision Collet Chuck			
Internal Lights	1 off			
Air Conditioner	optional			
Grinding Spindle				
Drive	Integral direct drive			
Power	RX7	19kW @6000rpm	25Hp	
	GX7	7.2kW @8500rpm	10Hp	
Speed	1800-10000rpm CW & CCW			
Sealing	Continuous Air Purge			
Cooling	Water Cooled			
Taper	ISO 30 nose taper			
Wheel Bore	31.75mm (1.25")max.			
Wheel Packs	2			
Wheels per Pack	4			
Max. Wheel Diameter	200 mm (8")			
Max. Wheel Speed	Refer to Wheel Manufacture specifications			
Max. Wheel Arbor Length	78 mm (3")			
Max. Wheel Pack Weight (total Wheel Pack Assembly)	8 kg			
Grinding Wheel Material	No restrictions			
Probe				
Type	Renishaw Probe LP2			



## RX7/GX7 User Manual

Tip Construction	Replaceable Carbide		
Machine			
Colour	RAL7035/RAL5014		
Electrical Power	20 kVA @ 380 to 480Volts		
Air Pressure	6.0 Bar	88 Psi	
Weight	4500 Kg	12,056 Lb	
Base Material	"ANCACRETE" Polymer Concrete		
LxWxH	2.5m x 2.0m x 1.9m	99"x 79" x 75"	

### 3.2.4 Motorized Spindle

The grinding spindle manufactured by ANCA also incorporates direct drive technology, therefore eliminating the need for another additional motor, pulleys and belt. This gives the spindle a super quiet operation. The variable speed spindle can be run in both CW and CCW directions from 1800 to 10,000 RPM. The spindle is liquid-cooled for stability, accuracy and reliability.

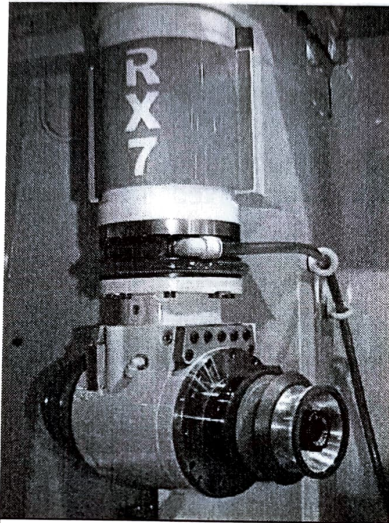

**Figure 3, Motorised Spindle**

### 3.2.5 Coolant Manifolds

Three programmable coolant solenoids are provided; one for the headstock and the other two for the grinding spindle.

The RX7/GX7 coolant manifold system allows for rapid coolant configuration changes.

Two manifolds can be set separately - one for each wheel. Each manifold is fixed in position by means of two captive M8 screws that can be undone in a matter of seconds with a battery operated drill. (Please refer to Figure 3 above).

Therefore, operators can build up a magazine of manifolds with coolant pipe setups for different operations. Of course, the position of coolant tubing needs to be verified to prevent collision during operation, but this only needs to be done once for each type of wheel pack – not every time the wheel pack is changed.

### **3.2.6 Direct Drive Axes**

All axes on the RX7/GX7 are direct drive. There are no gearboxes, gears, pulleys or belts. The rotor shaft of the motor is directly coupled to the ball screw of the X-, Y- and Z-axis. On the C and A axes, the rotor is built around the center hollow of the spindle. This totally eliminates backlash on all axes. Resolution of the A- and C-axes is 0.0001 degrees, far more accurate than our competitors. Using this technology allows us to index the headstock 300 degrees in 0.5 of a second.

All motors are also internally pressurized with air.

Each axis has automatic oil lubrication and is fully protected with bellows over ballscrews and rails, and fixed metal guards over the assemblies when required.

### **3.2.7 Wheelpack**

A Wheel pack is made up of several wheels (see Figure 4, Wheel Pack Assembly).

The wheel sleeve supplied allows a maximum wheel hub width of 78mm (3"). A wheel hub longer than this can impede C axis rotation and tool loading. A smaller size is available for single or double wheel packs; it can also be replaced when worn.

All parts should be clean when first assembled and when fastened to the grinding spindle.

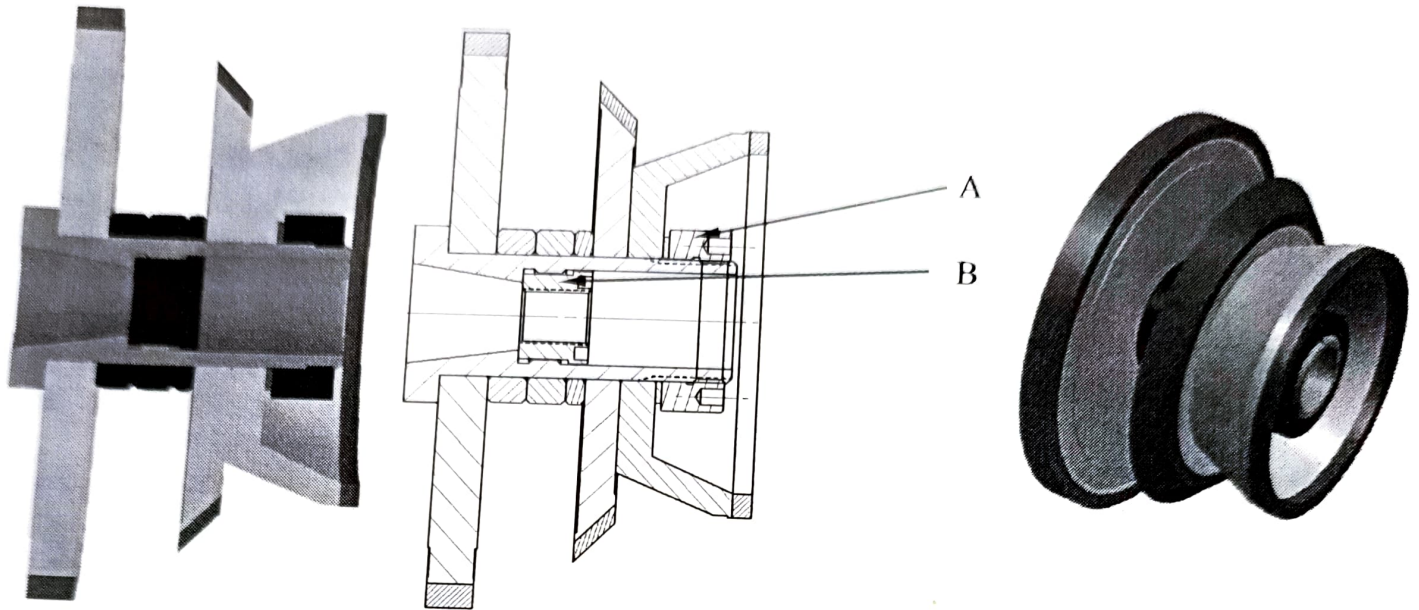

**Figure 4, Wheel Pack Assembly**

- Use locknut A with tab washer only. The minimum torque to tighten locknut A and B must be 20Nm.
- When using a cup wheel always ensure enough clearance with the C-axis column.
- All parts should be clean when first assembled and when fastened to the grinding spindle.