



Bharat Heavy Electricals Limited

Fabrication Stamping & Insulator Plant
Jagdishpur, Amethi – 227817(U.P.)

Office: 91(05361) 224119
Fax: 91(05361) 224243

MATERIAL MANAGEMENT

Notice Inviting Tender

Tender Enquiry No: TE-2200095

Dated: 20.12.2022

E-Tenders are invited in Two Part Bid System for the Supply of:

- COLD ROLLED NON-GRAIN ORIENTED SHEET STEEL, INSULATED GR:530 TM10472, and 0.5x710xCOIL as per technical documents.**
- COLD ROLLED NON-GRAIN ORIENTED SHEET STEEL GR:530, INSULATED, SPECS: AA10917 IS:648 (0.65 x 1235 x 1260) as per technical documents.**

(I) General:

- The tender will be under Two-part bid system i.e PQR cum techno commercial bid and Price bid.
- PQR is as below:

COMMON TECHNICAL PRE-QUALIFICATION REQUIREMENTS FOR CRNGO		
Sl.No.	Description of pre-qualification required	Supporting Documents required to accept Compliance
1	Mills are requested to furnish list of supply experience & corresponding Test certificates(date of TC should not be older than five years from BHEL tender date)for supply of technically identical/similar or better grade (in terms of lower losses) of CRNGO coils/sheets to OEM of Rotating electrical machines or power equipment manufacturers. Their offer against BHEL enquiry will be considered only when such vendors confirm clause-wise compliance of BHEL respective specifications.	1. Self –Declaration (self-signed by authorized signatory on Company’s letter head) of quantity supplied grade test certificates (with or without name of the customer) to be submitted. 2. Clause wise compliance of BHEL respective purchase specifications.
2	Offers are invited preferably directly from mill; however, authorized trading houses may also quote. Authorized trading houses (Distributors/agents/traders) have to submit a supplying mill’s authority certificate for participating in the tender in original for specific enquiry no. TE-2200095 on the Mill’s letter head duly signed by Mill’s authorized signatory (with full name, designation, valid email & contact number) along with the offer. In the absence of the above authority letter, offer from stockiest /trading houses are liable for rejection.	Valid certificate of being original manufacturers from OEM or Valid authorization letter from original manufacturers for authorized trading houses (Distributors/agents/traders).
3	Mills must have valid ISO-9001:2015 certificate for authorized, trading houses (Distributors/agents/traders) ISO certificate of principal to be submitted.	Valid ISO-9001:2015 certificate to be furnished. For authorized trading houses (Distributors/agents/traders) ISO Certificate of principal to be submitted.
4	Vendors have to furnish self –declaration for having manufacturing capacity to supply within six months the full ordered quantity for the item quoted.	Self-Declaration of mill’s is required.
5	Vendors ,using varnish otherwise as specified in BHEL specification, should inform name, brand and other details of Varnish(as per attached annexure-1 of BHEL Spec AA0851711) being offered for the material grade quoted against each respective tender requirement. BHEL. Reserves rights to ask Vendor for prompt supply of samples of ETS(with varnish coating offered by vendor) and sample of varnish.	For information, filled up Annexure-I of BHEL spec AA0851711 to be submitted.
6	All correspondence and documents shall be in English language .If any documents provided by vendors is in any language other than English, it must be supported with its English translation.	Compliance required.(Non-Qualifying criteria)

- Mode of Submission of offer:** Mode of Submission of offer: Being e-tender, offer will be submitted online through e-tender portal:



Bharat Heavy Electricals Limited

Fabrication Stamping & Insulator Plant
Jagdishpur, Amethi – 227817(U.P.)

Office: 91(05361) 224119
Fax: 91(05361) 224243

MATERIAL MANAGEMENT Notice Inviting Tender

<https://eprocurebhel.co.in/nicgep/app>

Important dates are given below:

EVENT	SCHEDULE
Last Date & Time for receipt of tender	Date : 30.12.2022 Time : 14.00 hrs (IST)
Tender Part I opening date & Time	Date : 30.12.2022 Time : 15.30 hrs (IST)

- In case of any difficulty faced while registering on BHEL's e-Procurement portal developed by NIC, queries may be addressed to 0120-4001002, 0120-4001005 and 0120-6277787; email: support-eproc@nic.in. These details are also available on 'Contact Us' page of the portal
- Offer to be submitted only on e-procurement portal. Hard copy/email offer is not required to be submitted to BHEL-FSIP. **Any offer received in Hard copy/Email shall not be accepted and straightway rejected by BHEL-FSIP**
- The offer shall be submitted as per the instructions of tender documents and as detailed in this NIT. Non acceptance of any term may lead to rejection of quotation.
- Rate shall be firm and there is no Price Variation.**
- On mutual consent BHEL may decrease the quantity.**
- Supplier has to quote prices in Rs per Metric Ton only.**
- Supplier has to submit technical deviation sheet and commercial deviation sheet, if deviating from BHEL Tender documents.**

(II) **Item Description and Scope of Supply:** Supplier has to supply below items as per technical documents.

Sl.No.	Material Code	Item Description	Qty (Nos)	Unit
1	SU1091799822	COLD ROLLED NON-GRAIN ORIENTED SHEET STEEL, INSULATED 530, TM10472, 0.5X710XCOIL	900	MT
2	SU1091717931	COLD ROLLED NON-GRAIN ORIENTED SHEET STEEL GR:530, INSULATED, SPECS: AA10917 IS:648 0.65X1235X1260	60	MT

(III) **Attachment to Tender Enquiry:**

Sl. No.	Description	Annexure/Enclosure
1	PQR cum Techno-Commercial Bid format	Annexure-IV
2	General Terms & Conditions (Make in India and Sister Concern Declaration)	Annexure: II
3	Special terms and Conditions	Annexure: III
4	Technical(Specifications) documents	Attached
5	Integrity Pact	Attached

(IV) **Contact person details:**



Bharat Heavy Electricals Limited

Fabrication Stamping & Insulator Plant
Jagdishpur, Amethi – 227817(U.P.)

Office: 91(05361) 224119
Fax: 91(05361) 224243

MATERIAL MANAGEMENT

Notice Inviting Tender

Manmeet Kumar
Dy. Manager –MM
Phone: 05361 224126/9478471278
E-mail: manmeet@bhel.in



SPECIAL TERMS AND CONDITIONS OF ENQUIRY (TE -2200095, dated 20.12.2022)

Sl. No.	Description
1	Product Requirement:
	a)CRNGO (0.5 x 710 x Coil) - 900 MT, STEEL SHEET ,GR:530, INSULATED, SPECS: TM10472, Rev-04
	b)CRNGO (0.65 x 1235 x 1260 SHEET) - 60 MT, STEEL SHEET GR:530, INSULATED, IS:648 , SPECS: AA10917
2	Delivery time and term:
	For (a) First 450 MT within 08 weeks and next 450 MT one month later to first lot.
	For (b) Within 08 weeks from date of PO.
	The rates quoted shall be on F.O.R- BHEL Stores basis without unloading charges. The rates shall be exclusive of unloading charges but inclusive of freight & Insurance. Early and Part Delivery (staggered delivery) is acceptable. Accordingly Penalty clause shall be applicable.
3	Distribution of Load Share:
	100% quantity shall be given to L1 bidder. But distribution shall be as per MSE clause and Make in India Clause if applicable.
4	Tender Finalization:
	Tender Finalization shall be through price bid opening.
5	Quantity Tolerance:
	For (a) There is +/- 5% Quantity variation is allowed.
	For (b) There is +/- 10% Quantity variation is allowed.
6	Test Certificate:
	Material test Certificate is required.
7	Special Instructions:
	For (a) CRNGO (0.5 x 710 x Coil) -900 MT - Coil weight shall be 3 MT-6 MT subjected to consideration of nominal ID of the coil to be 508 mm and maximum OD up to 1500 mm.
8	Evaluation:
	There is item wise evaluation

PQR cum Techno-Commercial Format

Tender Enquiry No- TE-2200095

Annexure-IV

1.PQR:

Sl No	Description	BHEL's Requirement	Suppliers Remarks
1	Mills are requested to furnish list of supply experience & corresponding Test certificates(date of TC should not be older than five years from BHEL tender date)for supply of technically identical/similar or better grade (in terms of lower losses) of CRNGO coils/sheets to OEM of Rotating electrical machines or power equipment manufacturers. Their offer against BHEL enquiry will be considered only when such vendors confirm clause-wise compliance of BHEL respective specifications.	1. Self –Declaration (self-signed by authorized signatory on Company’s letter head) of quantity supplied grade test certificates (with or without name of the customer) to be submitted. 2. Clause wise compliance of BHEL respective purchase specifications.	Submitted (Yes/No)
2	Offers are invited preferably directly from mill; however, authorized trading houses may also quote. Authorized trading houses (Distributors/agents/traders) have to submit a supplying mill’s authority certificate for participating in the tender in original for specific enquiry no. TE-2200095 on the Mill’s letter head duly signed by Mill’s authorized signatory (with full name, designation, valid email & contact number) along with the offer. In the absence of the above authority letter, offer from stockiest /trading houses are liable for rejection.	Valid certificate of being original manufacturers from OEM or Valid authorization letter from original manufacturers for authorized trading houses (Distributors/agents/traders).	Submitted (Yes/No)
3	Mills must have valid ISO-9001:2015 certificate for authorized, trading houses (Distributors/agents/traders) ISO certificate of principal to be submitted.	Valid ISO-9001:2015 certificate to be furnished. For authorized trading houses (Distributors/agents/traders) ISO Certificate of principal to be submitted.	Submitted (Yes/No)
4	Vendors have to furnish self –declaration for having manufacturing capacity to supply within six months the full ordered quantity for the item quoted.	Self-Declaration of mill’s is required.	Submitted (Yes/No)
5	Vendors ,using varnish otherwise as specified in BHEL specification, should inform name, brand and other details of Varnish(as per attached annexure-1 of BHEL Spec AA0851711) being offered for the material grade quoted against each respective tender requirement. BHEL. Reserves rights to ask Vendor for prompt supply of samples of ETS(with varnish coating offered by vendor) and sample of varnish.	Confiramtion on letter Head/filled up Annexure-I of BHEL spec AA0851711 to be submitted.	Submitted (Yes/No)
6	All correspondence and documents shall be in English language .If any documents provided by vendors is in any language other than English, it must be supported with its English translation.	Compliance required.(Non-Qualifying criteria)	Submitted (Yes/No)

2.Other Requirements:

1	Registraion Certificate under MSME Act if applicable	UDYAM to be submitted	Submitted (Yes/No)
2	CA certificate (Annexure I of GTC), If applicable	CA (Chartered Accountant) Certificate -on Format attached in GTC "Annexure-I" to be submitted	Submitted (Yes/No)
3	Declaration by vendor for Sister Concern(format in GTC)	Seal and signed on company letter head	Submitted (Yes/No)
4	Self-Declaration on Class I/Class II/Non Local under Make in India (format in GTC)	Seal and signed on company letter head	Submitted (Yes/No)
5	MSE owned by SC/ST declration, if applicable	Yes/No, If Yes, Provide supporting document	Submitted (Yes/No)
6	MSE owned by Women declration, if applicable	Yes/No, If Yes, Provide supporting document	Submitted (Yes/No)
7	Supplier has to submit technical deviation sheet and commercial deviation sheet, if deviating from BHEL Tender documents	On letter head	Submitted (Yes/No)
8	Acceptance of NIT, STC and GTC terms and conditions	Yes/No	Submitted (Yes/No)
9	Contact person name	To be given	
10	Contact person Mobile No.-	To be given	
11	Contact person E-mail id .-	To be given	
	Remarks if any		

Seal and Signed by Bidder



GENERAL TERMS AND CONDITIONS OF ENQUIRY

GTC/FSIP/PUR/01 Rev:01

Sl. No.	Description
1	General:
A	These General Terms & Conditions (GTC) shall apply to all enquiries, notice inviting tenders, request for quotations concerning the supply of goods and / or rendering of services to Bharat Heavy Electricals Ltd., Jagdishpur (hereinafter referred to as BHEL or the Purchaser) or its Projects / Customers. Special / supplementary terms and conditions of enquiry, if any, will override the conditions in this annexure.
2	General Instructions - Common for Indigenous & Foreign enquiries
A	Through E- procurement-
	<ol style="list-style-type: none"> 1. Offer shall be submitted by the bidders in single / two parts as called in Tender enquiry. 2. Bid Part - I Technical cum Commercial bid Bid Part - II Price bid 3. Suppliers shall quote price on BHEL/authorised third party service provider e-procurement site. Any deviation from the price format shall be clearly brought out in the offer Bid part-I. <p>The offer shall be uploaded on BHEL e-procurement site using Class III digital signature. Bidders to put sign and seal on all the uploaded documents. The quotation should be uploaded on the site before due date and time.</p> <p>Part-I of the bid shall contain complete item-wise scope of supply as offered vis-à-vis the scope of supply as per enquiry, all commercial terms and conditions etc. It is expected that bidders shall meet all our technical and commercial requirements and shall not deviate from them.</p>
B	Through Tender Room
B1	Sealed bids are invited for scope of Supply / Services as detailed in the enquiry. The quotation should be neatly typed and free from over writing/ erasures. Any correction or addition must be authenticated. The bid should be submitted in English or Hindi language. Relevant enclosures, supporting documents, catalogue, samples, if any, as required as per Notice Inviting Tender (NIT) conditions shall be sent along with technical offer. Rate should be quoted in the units asked for in the enquiry. The rates should be quoted both in figures and words. In case of discrepancy in figures and words, the rates quoted in words shall be considered.
B2	Bids shall be submitted in a Sealed cover with Enquiry No., Due date and Bidder's name indicated on the cover. In case of Two part Bid, technical bid containing technical offer, mandatory documents filled-in & signed; and un-priced copy of the tender should be kept in one envelope. Price Bid containing only the price (as called for in the price format where required) should be kept in a separate envelope. Both envelopes indicating Part-I or Part-II as the case may be to be put in a bigger envelope, which should be addressed to In charge, Tender Box, Administrative Building BHEL FSIP, Industrial Area Jagdishpur, Dist. Amethi-227817, (U.P.) India. Enquiry No., due date and bidder's name must be mentioned on all envelopes. Offer must reach tender box of BHEL FSIP Jagdishpur by 15.00 PM IST on the enquiry due date.
B3	Offer received after 15.00 PM IST of the due date will be termed as "Late Tender" and shall not be considered.
B4	Bidder can also submit offer through email, if called for in the enquiry, at the email address indicated in the enquiry. Such email offers shall be sent only on designated email-id to reach before 15.00 PM IST on the tender due date. BHEL will not be responsible for incomplete offers and the ones delivered late through e-mail.
C	Commercial Conditions quoted by the vendor in any place including as stated in bidder's 'General Terms and Conditions' if any, shall not be binding on the Purchaser and the conditions contained in this annexure, including special conditions, if any, for this enquiry shall only prevail.
D	<p><u>Wherever Reverse Auction is called for</u></p> <p>REVERSE AUCTION (RA): "BHEL shall be resorting to Reverse Auction (RA) (Guidelines as available on www.bhel.com) for this tender. RA shall be conducted among the techno-commercially qualified bidders. Price bids of all techno-commercially qualified bidders shall be opened and same shall be considered for RA. In case any bidder(s) do (es) not participate in online Reverse Auction, their sealed envelope price bid along with applicable loading, if any, shall be considered for ranking."</p> <p><u>Wherever Reverse Auction is not called for</u></p> <p>PRICE BID OPENING: Tender shall be finalized via price bid opening of all the techno-commercially qualified bidders in place of RA.</p>



GENERAL TERMS AND CONDITIONS OF ENQUIRY

GTC/FSIP/PUR/01 Rev:01

	Price bid should contain only price of item. Anything other than price of item shall be invalid. <i>Tender finalization mode (RA or Price bid opening) shall be specified in Special / supplementary terms and conditions of enquiry.</i>
E	The goods offered shall confirm to BHEL specifications and / or National/International standards as mentioned in the Enquiry and the bidder is required to confirm his unconditional acceptance to the same. Vendors, seeking deviations from the specifications and any other conditions, may indicate the same clearly on a separate sheet, with reasons for such deviations. BHEL reserves the right to reject the offer with deviations or load the deviations suitably for evaluation.
F	Offers shall be submitted directly by vendor or his authorized agent only. Unsolicited offers shall be summarily rejected.
G	Bid in single part or techno-commercial bid in two-part system (as the case may be) will be opened on the due date. In case of two part bid, price bids of techno-commercially acceptable bidder(s) only shall be opened on the assigned date.
H	In case of changes in scope and / or technical specification and / or commercial terms & conditions, having price implication, techno-commercially acceptable bidders shall be asked by BHEL to submit the impact of such changes on their price bids. In case a bidder opts to submit revised price bid instead of impact called for, then latest price bid shall prevail.
I	The bidders will submit Integrity Pact, duly signed by its authorized signatory, where called for in the enquiry.
J	Wherever the enquiry is issued to unregistered vendor, the bidder shall visit ' www.bhel.com and online filled up "Supplier Registration Form" on BHEL link (http://supplier.bhel.in) along-with all the supporting documents to be submitted.
K	BHEL expects that the bidder must respond to the enquiry. Regret letter, with valid reasons for not participating in the tender will be submitted where the bidder is unable to submit offer. Repeated lack of response on the part of vendor (Four non responses) may lead to his deletion from BHEL's approved vendor list.
L	Goods shall be properly packed to avoid transit damage. Suitable markings shall be provided to identify the goods with that of the PO No. and the consignee details.
M	Goods shall be consigned to Store Officer, BHEL, FSIP, IA Jagdishpur Dist- Amethi (U.P.) India, unless otherwise specified in the PO.
N	All corrigenda, addenda, amendments, time extensions, clarifications etc. to the tender will be hosted on BHEL website (www.bhel.com)/ https://eprocure.gov.in/epublish/app/ https://eprocurebhel.co.in/nicgep/app eProcurement website only.
O	In the course of evaluation, if more than one bidder happens to occupy L-1 status, effective L-1 will be decided by soliciting discounts from the respective L-1 bidders. In case more than one bidder happens to occupy the L-1 status even after soliciting discounts, the L-1 bidder shall be decided by a toss / draw of lots, in the presence of the respective L-1 bidder (s) or their representative(s). Ranking will be done accordingly. BHEL's decision in such situations shall be final and binding.
P	The Purchaser can consider awarding tendered quantities among more than one bidder (after acceptance of L1 price by the other bidders) in the manner and proportion disclosed in the tender conditions. Purchaser can also consider awarding of part of the tendered quantity to other than L-1 bidder at L1 counter offered rates, if the quantity offered by the L-1 bidder is less than the quantity tendered for. BHEL can also award order to L1 bidder/counter offer accepted bidders in case any bidder is not supplying/delaying the supplies and in this case the distributed quantity shall not be considered in loading share. The loading of Order shares on suppliers will also be subject to their performance (Quality, Delivery and Service) for the supplies made against Purchase Orders. The suppliers with consistence good performance will be preferred over poor performance supplier and encouraged with more order share. Depending upon performance in supplies BHEL shall go to redistribute the pending orders/shares of poor performer to other suppliers whose performance in supplies is better.
Q	The bidder shall submit price bid strictly in the price format, wherever provided for, in the enquiry. Any attempt on the part of the bidder to alter the contents of the price bid format in any manner, which in the opinion of BHEL can vitiate the tendering process, will lead to rejection of the bid, <i>besides BHEL taking appropriate punitive action as deemed fit.</i>



GENERAL TERMS AND CONDITIONS OF ENQUIRY

GTC/FSIP/PUR/01 Rev:01

R	In case the bidder decides to sub-contract part of his activity / work to some of his vendors, details of such intended subcontracting shall be mentioned in the bid. This will however not absolve the bidder from his contractual obligations and responsibilities.
S	Wherever the minimum reserved capacity is called for in the tender, the offers of such bidders, who do not quote for the minimum reserved capacity, are liable to be rejected.
3	Delivery Terms
A	Indigenous Purchase
	Goods shall be delivered on 'FOR Destination' basis (with freight and insurance in bidder scope) to the named destination unless otherwise called for in the enquiry.
B	Foreign Purchase — Imports
B1	<ol style="list-style-type: none"> 1. Goods shall be despatched by Sea, unless stated otherwise in the enquiry or purchase order. 2. Terms of Delivery for Sea shipment shall be on CFR / CIF basis with 14 days' detention free period for FCL (Full Container Load) Cargo of GP & HC Containers. 3. For other cases - Other than GP & HC Containers, LCL Cargo shall be delivered at Nhava Sheva (JNPT) & Break-bulk Cargo at Mumbai (MPT). 4. For Air consignments, the terms of delivery shall be FCA at BHEL nominated Airport. 5. Freight amount shall be indicated separately in the offer in case of CIP/CFR/CIF. 6. The number of detention free days and destination charges payable to shipping line must be mentioned in your offer and also on the Bill of Lading. 7. Offer received on FOB basis may be considered on an exceptional basis. BHEL will load freight, marine insurance & shipping line port handling charges etc. to work out landed cost at Sea Port. 8. Please visit BHEL Bhopal website www.bhelbpl.co.in for details of named Air ports and Sea ports. Name of the gateway port so chosen by the Seller shall be indicated by the Bidder in his offer.
B2	<ol style="list-style-type: none"> 1. For delivery of FCL (Full Container Load) cargo, the Bidder shall provide minimum 14 days' detention free period from the date of delivery at Port of Discharge / Place of Delivery (in case of ICD). Wherever the detention free period offered is less than 14 days, the bids shall be loaded for the period short of 14 days' period. 2. <u>Port Congestion charges or any additional charges claimed by the shipping line at Port of Discharge / Place of Delivery shall be to the Seller's account.</u>
4	Vendor's particulars & logistics information (Bidder to give details against each of the provisions)
A	Name of the vendor's executive to deal with this tender / project
B	E-mail address of the contact person
C	Telephone no. of the contact person
D	Name of location from where the goods shall be offered for inspection and dispatch
5	Additional logistics information for Imports
A	Bid currency
B	Charges applicable at discharge port up to BHEL's CFS (Container Freight Station) to be indicated in your offer and on the B/L
C	Name of Airport in the country of dispatch for FCA delivery terms
D	Estimated number, type & size of containers for delivery of tendered



GENERAL TERMS AND CONDITIONS OF ENQUIRY

GTC/FSIP/PUR/01 Rev:01

	quantity (applicable where the goods are to be sent in FCL)	
E	No. of packages with cumulative gross weight and CBM volume (applicable for LCL & Break-bulk shipment)	
F	Approx. distance in km. from Vendor's works to Port of Loading	Sea port /Air port
6	Delivery Schedule & Completion date	
A	<ul style="list-style-type: none"> • Instead of writing specific date against delivery offered, bidder shall commit delivery period in number of days / weeks/ months to suit the delivery period indicated in the enquiry. • Commencement of delivery period shall be reckoned from the date of PO / LOI or any other agreed milestone. • Seller shall deliver the goods in the manner and schedule agreed under the Purchase order. • Goods shall be delivered within contractual period or any extension thereof, if any, granted by the Purchaser. • If delivery is linked to approval of documents, time for submission of such documents to be indicated and delivery period to be indicated from approval of documents. This delivery schedule will be considered for processing delivery extension, wherever applicable. • BHEL reserves the right to cancel the order if material is not delivered within PO scheduled delivery. • In case of unsatisfactory performance on quality / delivery BHEL will have right to discontinue the contract in part or full. 	
B	In case of foreign supplies, the date of Bill of Lading (B/L) or AWB shall be taken as actual date of delivery.	
C	In case of Indigenous bidders, the date of delivery at named destination in India shall be taken as contractual delivery completion date where delivery terms are FOR destination. In case of 'Ex-works' delivery terms, the date of LR / RR shall be the contractual delivery completion date.	
7	Transit Insurance	
	Except where delivery terms are agreed on CIF basis for Imports & FOR destination basis for indigenous purchases, transit insurance will be covered by BHEL under its Open Marine Transit Insurance Policy. Seller shall inform dispatch particulars with value of consignment to the Purchaser within 07 days of dispatch for BHEL to arrange insurance coverage in its policy. Failure on the part of seller to inform dispatch particulars will make him liable to pay for any transit damages / losses suffered by the Purchaser.	
8	Force Majeure	
	<p>Notwithstanding anything contained in the contract, neither the Seller nor the Purchaser shall be held responsible for total or partial non-execution of any of the contractual obligations, should the obligation become unreasonably onerous or impossible due to occurrence of a 'Force Majeure' which directly affects the obligations to be performed by the Purchaser or the Seller; Such events include war, military operations of any nature, blockages, revolutions, insurrections, riots, civil commotions, insurgency, sabotage, acts of public enemy, fires, explosion, epidemics, quarantine restrictions, floods, earthquake, or acts of God, restrictions by Govt. authorities; over which the Seller or the Purchaser has no control.</p> <p>The party claiming to be affected by force majeure shall notify the other party in writing without delay, within two weeks on the intervention and on the cessation of such circumstance. Extension of time sought by the Seller along with supporting evidence and so granted by the Purchaser for the supply/ work affected, if any, shall not be construed as waiver in respect of remaining deliveries. Rescheduling of deliveries on account of force majeure conditions, if so agreed by the Purchaser, will not entail the Seller to claim any increase in the price on whatsoever account.</p> <p>Notwithstanding above provisions, Purchaser shall reserve the right to cancel the order/ Contract, wholly or partly, in order to meet the overall project schedule and make alternative arrangements. If deemed necessary, Purchaser may takeover partly processed material at a mutually agreed price.</p>	
9	LD/Penalty for delayed performance.	
A	<p>Subject to force majeure conditions,</p> <p>I. LD shall be 0.5 % of the total order value per week of delay or part thereof subject to a maximum of 10% of the total order value.</p>	



GENERAL TERMS AND CONDITIONS OF ENQUIRY

GTC/FSIP/PUR/01 Rev:01

	<p>II. In case of staggered delivery schedule, LD shall be 0.5 % of the undelivered portion per week of delay or part thereof subject to a maximum of 10% of the total order value. However, even if a staggered delivery schedule for Capital Machine / BOPs is agreed, the LD cap will be levied on total order value and not undelivered portion of the order value.</p> <p>III. In case of any amendment/ revision, the LD shall be linked to the amended / revised PO value.</p> <p>Any deviation from the above LD clause shall be specified separately in the NIT. Any loading on LD/penalty clause shall be to the extent to which it is not agreed to by the bidder (at offered value). The same shall be intimated separately prior to price bid opening.</p> <p>Note: “Recovery of LD will include GST as applicable”.</p>
	In case the contractually agreed delivery date falls on a holiday in BHEL FSIP Jagdishpur, the next working day shall be taken as contractual delivery date for compliance and applicability of LD / penalty.
B	Risk Purchase
	If the material is not supplied within the agreed delivery period, BHEL reserves the right to cancel the order and purchase the material from alternate source (s) at the Risk and Cost of the Seller. In such an event, it shall be obligatory on the part of seller to make good any loss suffered by the purchaser.
10	Indian Agents and Agency commission
A	BHEL prefers to deal directly with Foreign vendor, wherever required, for procurement of Goods. However if the Foreign Principal desires to avail services of an Indian Agent, then the Principal should ensure compliance to "regulatory guidelines" which will require submission of an agency agreement.
B	The CFR / CIF price quoted will be deemed to be inclusive of Indian Agency commission. Agency commission as disclosed by the bidder in his quoted CFR / CIF price will be paid in Indian Rupees on receipt & acceptance of Materials or it's installation at destination, as the case may be. The lower of the 'TT buying rate prevailing on the date of technical bid opening or price bid opening shall be considered for computation of Agency commission.
C	In a tender either the Indian Agent on behalf of Principal / OEM or the Principal / OEM itself can bid, but both cannot bid simultaneously for same item / product in the same Tender. In case bids are received from both the Principal / OEM and the agent, bid received from the agent will be ignored.
D	If an agent submits Bid on behalf of the Principal / OEM, the same agent shall not submit bid on behalf of another Principal / OEM in the Tender, for the same Item / Product.
11	Documentation:
A	Indigenous Purchase
	Seller shall arrange to send to the consignee, Original Tax invoice (Buyer's copy and duplicate for Transporter), Commercial invoice in duplicate, consignee copy of LR & 2 sets each of Packing list, Test certificate, Guarantee / Warranty certificate, O & M manuals (where applicable), immediately on despatch of the goods. The distribution of such documents will be specified in the Purchase order.
B	Foreign Purchase — Imports
	<p>A. Vendor to share immediately Bill of lading with Import Invoice and packing list of material at mssea@bhel.in and incorporate following detail in the bill of lading:</p> <p>a. Import & export Code (IEC) of importer;</p> <p>b. GST Identification No (GSTIN) of importer;</p> <p>c. Official email id of importer (to be used for correspondence by shipping lines and Customs) – mssea@bhel.in to be included.</p> <p>B. Seller shall send 1 set of following documents, in English, within 7 days of B/L date / 1 day of AWB date by courier to the Purchaser.</p> <ol style="list-style-type: none"> 1. Express / Original 'Clean on board' Bill of Lading / AWB. 2. One set of Commercial Invoice, Packing list indicating container-wise Gross weight, Net weight, CBM volume, No. of packages with Dimensions of each package.



GENERAL TERMS AND CONDITIONS OF ENQUIRY

GTC/FSIP/PUR/01 Rev:01

	<p>3. Original Certificate of Country of Origin issued by Chamber of Commerce.</p> <p>4. One set of Original Test Certificates and O&M Manual where called for.</p> <p>5. Fumigation / Phyto Sanitary Certificate wherever cargo is packed in wooden packing or packing of plant origin material is used.</p> <p>6. Supplier should additionally forward 2 sets of original documents mentioned at point 1 to 5 along with original bill to Lading through any international courier service / registered airmail or AWB by captain's mail within three days of obtaining the same directly to the following:</p> <table style="width: 100%; border: none;"> <tr> <td style="width: 50%; vertical-align: top;"> <p>(i) AGM (M.S) Regional Operations Division BHEL 14th Floor Centre-1 World Trade Centre, Cuffe Parade Colaba, Mumbai 400 005 INDIA E-mail: mssea@bhel.in</p> </td> <td style="width: 50%; vertical-align: top;"> <p>(ii) SDGM (FIN) Administrative Bldg. BHEL, FSIP, IA Jagdishpur Amethi, 227817, UP, India E-mail : shashi.kumari@bhel.in</p> </td> </tr> </table> <p>And confirm forwarding details to DGM (MM), BHEL, FSIP, IA Jagdishpur 227817, Amethi , UP, India at nasaifi@bhel.in /pk Yadav@bhel.in/vjain@bhel.in.</p> <p>7. In case the Seller decides to negotiate all 3 originals of B/L / AWB along with all original documents through negotiating Bank, non-negotiable documents (NNDs) consisting of copy of B/L / AWB & documents mentioned at Sl. no. 11- B2 to B5 will be sent by e-mail to the Purchaser at his e-mail address given in the PO with one copy to be mailed at nasaifi@bhel.in & vjain@bhel.in (for sea shipment). Other documents, as required, will be separately indicated in the Purchase Order. Additional expenditure, if any, incurred by the Purchaser by way of detention / demurrage, resulting out of delay attributable to the Seller in providing Negotiable documents, will be recovered from the Seller.</p> <p>In case any discrepancy is raised by bankers / BHEL with respect to documents submitted, vendor to facilitate clearance of goods through Delivery Order.</p>	<p>(i) AGM (M.S) Regional Operations Division BHEL 14th Floor Centre-1 World Trade Centre, Cuffe Parade Colaba, Mumbai 400 005 INDIA E-mail: mssea@bhel.in</p>	<p>(ii) SDGM (FIN) Administrative Bldg. BHEL, FSIP, IA Jagdishpur Amethi, 227817, UP, India E-mail : shashi.kumari@bhel.in</p>
<p>(i) AGM (M.S) Regional Operations Division BHEL 14th Floor Centre-1 World Trade Centre, Cuffe Parade Colaba, Mumbai 400 005 INDIA E-mail: mssea@bhel.in</p>	<p>(ii) SDGM (FIN) Administrative Bldg. BHEL, FSIP, IA Jagdishpur Amethi, 227817, UP, India E-mail : shashi.kumari@bhel.in</p>		
C	General		
	<p>1. For Hazardous chemicals, the materials safety data sheet (MSDS) is to be submitted.</p> <p>2. All certificates as called must be sent. BHEL may test any goods supplied and their decision is final irrespective of supplier's certificates. If test certificate and guarantee certificate are not received along with the document and stipulated in these specifications, BHEL reserves the right to get the material tested and recover the expenses from the supplier without awaiting supplier's confirmation</p>		
12	Pricing Terms:		
	Prices once quoted shall remain firm within the validity or any extension thereof for placement of order, till complete execution of the order, without any escalation / increase for any reason, whatsoever, unless specifically provided for in the Enquiry & PO. In case of foreign vendors, the quoted price shall be taken as inclusive of Third Party Inspection and testing charges as called for in the NIT.		
13	Price Validity :		
	Unless stated otherwise in the enquiry, offer shall be valid for a period of 90 days from the date of Techno- commercial (Part-I) bid opening date.		
14	Taxes & Duties - Indigenous Purchase:		
A	Vendor to ensure timely remittance of SGST, CGST, IGST as applicable in time as per law.		
B	Vendor to ensure compliance to filing of monthly GST sales return including BHELs supplies by 10 th of next calendar month in the online GST portal wherever applicable.		
C	Vendors to declare filing of timely returns and GST remittance / likely remittance / ITC adjustment along with invoice.		
D	Vendor to submit invoices compliant with GST invoice Rules		
E	Vendors to comply with all statutory provisions as may be applicable at the time of despatch / sale. Any additional financial liability to BHEL on account of non-compliance by vendors shall be borne by them and shall be adjusted / recovered from the vendors. BHEL reserves the right to review the existing offers / contracts for any revision in terms, which may arise due to change in any statutory provisions to ensure that the benefit accrues to BHEL.		



GENERAL TERMS AND CONDITIONS OF ENQUIRY

GTC/FSIP/PUR/01 Rev:01

F	Vendor to ensure TAX INVOICE submission along with consignment
G	<p>In respect of cases where the liability to discharge GST is on BHEL under reverse charge mechanism, vendors have to ensure timely submission of invoices and delivery of material / services to BHEL, so that there is no mismatch on both activities. In case there is any additional financial liability on BHEL on account of default on the part of the vendor on submission or delivery of material / services the same shall be passed on to them.</p> <p>In respect of free issue material by BHEL, vendors have to return the processed material within the time line as per the provisions of GST. In case of any additional tax liability on BHEL on account of non-compliance by the vendor, the additional financial implications on BHEL shall be passed on to the vendor.</p>
H	Vendors to provide the applicable HSN / SAC codes as called for in the enquiry
15	Taxes & Duties - Foreign Purchase — Imports
	The offered prices shall be inclusive of all the Taxes and duties as applicable in the country of bidder / country of dispatch for the quoted CFR / CIF price.
16	Payment Terms-
A	Indigenous: 100% payment in 90 days of receipt (45 days for MSE including NSIC / Udyog Aadhar/UDYAM/EM-II/DIC along with valid CA certificate, registered suppliers as per relevant act in force), subject to acceptance of material at BHEL, on direct presentation of the documents. In case of despatch of material to site directly, site certification for receipt of materials is required unless otherwise provided for in the PO.
B	Foreign: 100% direct Payment payable on 90 th day of B/L / AWB.
	<p>Any deviation from the above payment terms, if accepted (by BHEL), shall be loaded as per below point:</p> <p>(i) 'Base rate of SBI (as applicable on the date of bid opening; Techno-commercial bid opening in case of two part bids) + 6%' shall be considered for loading for the period of relaxation sought by bidders.</p> <p>(ii) Wherever LC payment terms are not offered in NIT and the same is insisted by bidder(s), all LC related bank charges to be incurred by BHEL shall also be loaded.</p> <p>(iii) In case of deviation w.r.t. LC payment terms offered in NIT, the loading shall be done for all LC related bank charges to be incurred by BHEL.</p>
C	<p>Foreign vendors to submit declaration of Permanent Establishment and Business Connection (PEBC) for remittances purpose. Declaration to be submitted in formats in either Annexure A or B whichever is applicable as per their transaction entered into with BHEL.</p> <p>In the absence of certificates from the vendor, withholding tax at applicable rates along with surcharge and cess will be recovered at the time of remittance to the vendor.</p>
D	Foreign vendors to submit Tax Residency Certificate (TRC) & Form 10 F (for obtaining DTAA benefits) as per Annexure C in respect of services. The TRC (tax residency certificate) is to be issued by the authorities of the government of vendor's country. If the informative part of the format (other than residency) is not furnished by the authorities the same may be furnished by the vendor as a declaration.
17	Inspection of Goods
A	The Seller shall give adequate notice, of 1 week or as mutually agreed period, in writing to the Purchaser (in case Customer inspection is involved) or BHEL appointed TPIA about the date and place at which the goods will be ready for inspection/ testing, as provided for in the contract.
B	<p>Purchaser or his authorized representative shall be entitled to carry out inspection of material and Workmanship / Surveillance Audit at Seller's premises or at his sub-contractor's premises at all reasonable times during execution of contract; Such inspection, examination and testing, if made, shall not absolve the Seller from his obligations under the contract.</p> <p>Wherever required, BHEL may carry out testing at BHEL's testing Lab and in case of any rejection during such testing, replacement / rectification, as required, will have to be done by Supplier.</p> <p>If BHEL carries out any rectification of such rejected material, such cost will be recovered from Supplier's Bills.</p> <p>In case of Customer inspection as Supplier's Works, inspection clearance to be obtained from Customer and submitted to BHEL.</p>



GENERAL TERMS AND CONDITIONS OF ENQUIRY

GTC/FSIP/PUR/01 Rev:01

C	BHEL's representative from unit or Corporate Quality (CQ) is authorised to carry out audits along with TPIA at vendor's works before clearing the items for despatch.
D	All costs related to inspections and re-inspections shall be borne by the Seller. In case of inspection by BHEL and / or BHEL's customer, the cost of to & fro passage and Boarding & Lodging shall be borne by the Purchaser / Customer, unless otherwise specifically agreed. In case of foreign vendors, the cost of third party inspection, where called for, shall be deemed to be included in the quoted price. Seller shall be responsible to provide assistance such as labour, materials, electricity, fuels, stores, apparatus, instruments at his cost, as may be required and as may be reasonably demanded to carry out such tests effectively.
E	<p>REJECTION: If any goods are rejected, BHEL shall be at liberty to take action as per following at the risk and cost of supplier:</p> <ul style="list-style-type: none"> a) Allow the supplier, wherever mutually agreed, to rectify the rejected goods at BHEL's works within reasonable time as fixed by BHEL. or b) Allow the supplier to make free replacement within a specified period. Rejected goods can be lifted by the supplier there after. or c) In case payment has been done, allow supplier to refund equivalent value of rejected material by NEFT / RTGS or furnish Bank Guarantee for same amount before lifting the rejected goods. Fresh replacement shall be regulated as per terms and condition of the original Purchase Order. In case payment has not been done, allow the supplier, wherever mutually agreed, to rectify the rejected goods at supplier's works within reasonable time as fixed by BHEL. or d) Take alternate procurement action from elsewhere and recover the difference in total cost to BHEL including services, if any, incurred by BHEL in this regard from the supplier. The supplier shall not be entitled to any gain on repurchase. or e) Terminate the contract either in part or in whole at the discretion of BHEL and recover the loss, if any, from the supplier. or f) Any goods rejected by BHEL must be removed by the supplier after making payment through NEFT / RTGS within 45 days from the date of intimation of rejection or 30 days after receipt of the intimation of rejection whichever is earlier. If vendor fails to lift or allow despatch of rejected material at his cost within 90 days from the intimation of rejection, his claim on rejected material shall cease.
	<p>REJECTION: The supplier shall arrange replacement/repair within one month from the date of rejection intimation upon failure on supplier's part to comply. BHEL will take whatever appropriate action they may think fit in addition to repair/return of rejected material at the cost and risk of the supplier.</p>
18	Guarantee / Warranty and corresponding Repairs / Replacement of Goods
	<p>Manufacturer's works test / infection certificates shall be furnished along with the guarantee that material conforms strictly to the specification for general & special conditions as laid down in the purchase order. Goods shall comply with the specifications for material, workmanship and performance. The warranty shall be for a period of 12 months from the date of receipt. If the delivery is found non-compliant during the warranty period, leading to rejection, the Seller shall arrange free replacement / repair of goods, within one month from the date of intimation or any mutually agreed period. The rejected goods shall be taken away by the Seller at his cost and replaced on Delivered Duty Paid (DDP) (FOR - BHEL Stores / designated destination basis) within such period. In the event of the Seller's failure to comply, Purchaser may take action as appropriate, including Repair / Replenish rejected goods & disposal of rejections, at the risk & cost of the Seller. In case the defects attributable to Seller are detected during processing of the goods at purchasers/ his subcontractor's works, the Seller shall be responsible for free replacement / repair of the goods as required by the purchaser.</p>
19	Evaluation and Loading Criteria:



GENERAL TERMS AND CONDITIONS OF ENQUIRY

GTC/FSIP/PUR/01 Rev:01

	<p>Evaluation of the tender shall be on the basis of delivered cost, i.e. 'total cost to BHEL' w.r.t the technical scope and commercial conditions finalized after techno-commercial clarifications (after considering, inter alia, Customs Duty and GST / Other taxes as applicable). Exchange rate (TT selling rate of State Bank of India) applicable on the date of Part-I bid opening shall be considered for evaluation of foreign bids. If the relevant day happens to be a bank holiday in India, then the FOREX rate as on the previous bank working day shall be taken for evaluation.</p> <p>Foreign suppliers shall ensure that the benefits as applicable under Comprehensive Economic Partnership Agreement (CEPA) with Government of India are disclosed in the bid & relevant documents such as Certificate of Country of Origin, issued by the appropriate authority in the country of Export is provided by the vendor along with dispatch documents. Bids shall be evaluated with such applicable benefits. In the event of Seller failing to provide appropriate documents for Purchaser to avail disclosed concessional duty benefits in India, financial loss, so incurred, will be to the Seller's account.</p>
	The evaluation currency for this tender shall be INR.
20	Variation of orders
	No variation to the Purchase order is permitted unless authorised in writing and signed by or on behalf of purchase executive, BHEL Jagdishpur.
21	Sub-contract
	BHEL's order or part there off, if further to be subcontracted in exceptional circumstances the details of subcontracting and to whom to be subcontracted shall be furnished to BHEL and written permission shall be obtained from BHEL. However, it shall not absolve the supplier of the responsibility of fulfilling BHEL order requirements.
22	Recovery / deductions of amount from supplier
	<p>A) Any amount on account of recovery from consignor / supplier under any condition shall be liable to be adjusted against any amount payable to the consignor / supplier against bills.</p> <p>B) For any deficiency in supplies where deduction is involved, an amount as decided by BHEL, shall be deducted from supplier's bills.</p>
23	Safety clause for Purchase Orders
	<p>The vendors shall maintain and ensure sufficient safety measures as required for inspections and test like HV test. Pneumatic test, Hydraulic test Spring test, Bend test, Material handling and safe working environment etc. to enable Inspection Agency for performing inspection.</p> <p>The vendor shall ensure that all the safety precautions specified in factories Act 1948 chapter-IV Section-21 to 41 are complied with respect to equipment's to be inspected.</p> <p>If any test equipment is found not complying with proper safety requirement, then the inspection agency may withhold inspection, till such time the desired safety requirements are met.</p>
24	Non-Disclosure Agreement
	<p>All Drawing and technical documents relating to the product or it's manufacture submitted by one party to the other, prior or subsequent to the formation of contract, shall remain property of the submitting party. Drawing, technical documents or other technical information received by one party, shall not without the consent of the other party, be used for any other purpose than that, for which they were provided. Such technical information shall not without the consent of the submitting party, otherwise be used or copied, reproduced, transmitted or communicated to a third party. Patterns supplied by BHEL will remain BHEL's property which shall be returned by the bidder on demand to BHEL. Bidder shall in no way share or use such intellectual property of BHEL to promote his own business with others. <u>BHEL reserves the right to claim damages from the bidder, or take appropriate penal action as deemed fit against the bidder, for anv infringement of the provisions contained herein.</u></p>
	<p>DRAWINGS, PATTERNS & TOOLS: All drawings, patterns & tools supplied by BHEL or made at BHEL's expense are BHEL's property. These cannot be used or referred to any other party and must only be used in the execution of BHEL's orders. These should be preserved at the supplier's cost for a period of not less than 5 years. Patterns & tools should be returned to BHEL within 90 days of issue of the same.</p>
25	Settlement of Disputes & Arbitration
A	All questions / interpretations regarding subject matter of the Contract shall be decided by the Purchaser on the request of the Seller and the decision of the Purchaser shall be final.
B	In case of dispute, steps shall be taken by the parties to the contract to settle the same through negotiations.



GENERAL TERMS AND CONDITIONS OF ENQUIRY

GTC/FSIP/PUR/01 Rev:01

C	In case, dispute is not settled in negotiations, it shall be referred to Conciliator appointed by the competent authority of the Purchaser.
D	<p>Except as provided elsewhere in this Contract, in case amicable settlement is not reached between the Parties, in respect of any dispute or difference; arising out of the formation, breach, termination, validity or execution of the Contract; or, the respective rights and liabilities of the Parties; or in relation to interpretation of any provision of the Contract; or, in any manner touching upon the Contract, then, either Party may, by a notice in writing to the other party refer such dispute or difference to the sole arbitration of an arbitrator appointed by Head of the BHEL Unit/Region/Division issuing the Contract. The Arbitrator shall pass a reasoned award and the award of the Arbitrator shall be final and binding upon the Parties. Subject as aforesaid, the provisions of Arbitration and Conciliation Act 1996 (India) or Statutory modifications or re-enactments thereof and the rules made thereunder and for the time being in force shall apply to the arbitration proceedings under this clause. The seat of arbitration shall be Lucknow.</p> <p>The cost of arbitration shall be borne as per award of the Arbitrator.</p> <p>Subject to the arbitration in terms of Clause above, the Courts at Lucknow shall have exclusive jurisdiction over any matter arising out of or in connection with this Contract.</p> <p>Notwithstanding the existence or any dispute or differences and / or reference for the arbitration, the Contractor shall proceed with and continue without hindrance the performance of its obligations under this Contract with due diligence and expedition in a professional manner except where the Contract has been terminated by either Party in terms of this Contract.</p>
	<p>In case of Contract with Public Sector Enterprise (PSE) or Government Department, the following shall be applicable: In the event of any dispute or difference relating to the interpretation and application of the provisions of the Contract, such dispute or difference shall be referred by either Party for arbitration to the sole arbitrator in the Department of Public Enterprises to be nominated by the Secretary to the Government of India in-charge of the Department of Public Enterprises. The Arbitration and Conciliation Act, 1996 shall not be applicable to arbitration under this clause. The award of the arbitrator shall be binding upon the Parties to the dispute, provided, however, any Party aggrieved by such award may make further reference for setting aside or revision of the award to the Law Secretary, Department of Legal Affairs, Ministry of Law and Justice, Government of India. Upon such reference the dispute shall be decided by the Law Secretary or the Special Secretary or Additional Secretary when so authorized by Law Secretary, whose decision shall bind the Parties hereto finally and conclusively. The Parties to the dispute will share equally the cost of arbitration as intimated by the Arbitrator.</p>
E	The Seller shall continue to perform the contract, pending settlement of dispute(s).
26	Applicable Laws and Jurisdiction of Courts
	Indian laws both substantive and procedural, for the time being in force, including modifications thereto, shall govern the Contract including Arbitration proceedings. The competent Courts at Lucknow in the State of Uttar Pradesh, India shall have sole jurisdiction.
27	RIGHT OF REJECTION /NON- PLACEMENT OF PO: BHEL reserves the right to accept the offers in part or in full, or cancel the Tender enquiry without assigning any reason.
28	Performance Bank Guarantee (PBG) / Security Deposit (SD)-(If applicable)
A	Wherever PBG/SD (covering equipment / system / work performance guarantee) is called for in the Notice Inviting Tender (NIT) deviation shall not be accepted.
B	Bank Guarantee wherever called for, shall be in the BHEL prescribed format. In case the order is to be placed in foreign currency, the BG must also be in Foreign currency, so specified by the Purchaser.
C	Wherever Security Deposit (covering contract performance) is called for in the NIT, deviation shall not be accepted.
D	Composite 'Contract Performance Bank Guarantee' of matching value / validity, where both Security Deposit and Performance Bank Guarantee are required, shall not be construed as deviation.
E	Wherever the contract is for supply of Goods processed on labour basis from BHEL supplied materials, the materials shall be issued against a suitable Bank guarantee as specified in the Enquiry.
29	Benefits earmarked for Purchase from Micro & Small Enterprises (MSEs) — Indigenous Purchase
A	MSE bidders shall submit along with bid relevant documents w.r.t. their respective MSE status as per extant norms. Date to be reckoned for determining the deemed validity will be the last date of Technical bid submission. Non- submission of such document will lead to consideration of their bid, at par with other bidders and MSE status of such bidders shall be shifted to Non- MSE supplier till the supplier submit these documents.



GENERAL TERMS AND CONDITIONS OF ENQUIRY

GTC/FSIP/PUR/01 Rev:01

B	<p>In tender, participating MSEs quoting price within price band of L1+15% shall also be allowed to supply a portion of requirement by bringing down their price to L1 price in a situation where L1 price is from someone other than a MSE and such MSE shall be allowed to supply up to 25% of total tendered value. In case of more than one such MSE, the supply shall be shared proportionately. A quantum of 6.25% out of 25% quantity, so earmarked, will be reserved for MSE's owned by SC / ST entrepreneurs who submit their bid with relevant documents provided that in event of failure of such MSE(s) to participate in tender process or meet tender requirements and L1 price, 6.25% sub-target for procurement earmarked for MSE(s) owned by SC or ST entrepreneurs shall be met from other MSE(s).</p> <p>Special provision for Micro and small enterprises owned by Women in following cases: - 3% reservation for women owned MSEs under following conditions</p> <ol style="list-style-type: none"> i. In case of Proprietary MSE, proprietor is woman. ii. In case of partnership MSE, the woman partner is holding at least 51% share in the unit. iii. In case private limited companies, at least 51% share is held by woman promoters. <p>In case of indivisible tender the full quantity shall be awarded to L1.</p>
C	<p>If an enterprise falling under MSE category as defined in the MSMED Act 2006, graduates to a higher category from its original category or beyond the purview of the Act, it shall continue to avail all non-tax benefits of its original category notified by the Ministry of Micro, Small and Medium Enterprise for a period of three years from the date of such graduation to the higher category.</p>
D	<p>MSE suppliers can avail the intended benefits only if they submit along with the offer, attested copies of either EM II certificate having deemed validity (five years from the date of issue of acknowledgement in EM II) or valid NSIC certificate or EM II certificate along with attested copy of a CA certificate (As per BHEL Format, where deemed validity of EM II certificate of five years has expired) applicable for the relevant financial year (latest audited). Date to be reckoned for determining the deemed validity will be the date of bid opening (Part 1 in case of two part bid). Non submission of such documents will lead to consideration of their bid at par with other bidders. No benefits shall be applicable for this enquiry if any deficiency in the above required documents are not submitted before price bid opening. If the tender is to be submitted through e-procurement portal, then the above required documents are to be uploaded on the portal. Documents should be notarized or attested by a Gazetted officer</p>
30	<p>Integrity Pact (IP) — Independent external monitors (IEM) For tenders in which integrity pact is applicable, following points stand valid :</p>
A	<p>IP is a tool to ensure that activities and transactions between the company and its bidders / contractors are handled in a fair, transparent and corruption free manner. A panel of Independent External Monitors (IEMs) have been appointed to oversee implementation of IP in BHEL.</p> <p>The IP as enclosed with the tender is to be submitted (duly signed by authorized signatory who signs in the offer) along with techno commercial bid. Only those bidders who have entered into such an IP with BHEL would be competent to participate in the bidding. In other words, entering into this pact would be a preliminary qualification.</p> <p>Name : ----- Address : ----- mail : -----</p> <p style="text-align: right;">} As indicated in NIT / enquiry :201__</p>
B	<p>Please refer section 8 of the IP for roles and responsibilities of IEMs. In case of any complaint arising out of tendering process, the matter may be referred to the IEM mentioned in the tender.</p> <p>NOTE: No routine correspondence shall be addressed to the IEM (phone / post / e-mail) regarding the clarifications, time extensions or any other administrative queries, etc. on the tender issued. All such clarifications / issues shall be addressed directly to the tender issuing (procurement) department.</p>
31	<p>Fraud Prevention Policy : The Bidder along with its associate / collaborators / sub-contractors / sub-vendors / consultants / service providers shall strictly adhere to BHEL Fraud Prevention Policy displayed on BHEL website www.bhel.com and shall immediately bring to the notice of BHEL Management about any fraud or suspected fraud as soon as it comes to their notice.</p>
32	<p>GSTN nos. of vendors as well as GSTN No of BHEL must be mentioned on the invoices/bills of the materials. Please note that correct HSN code as well as rate of GST be mentioned in the invoice/bills.</p>
33	<p>BHEL FSIP GSTIN Reg. No: 09AAACB4146P22C State Code: 09 (Uttar Pradesh)</p>



GENERAL TERMS AND CONDITIONS OF ENQUIRY

GTC/FSIP/PUR/01 Rev:01

34	<p>(a) Right of Acceptance: BHARAT HEAVY ELECTRICALS LIMITED JAGDISHPUR reserves the right to reject any or all the bids/quotations without assigning any reason thereof. BHEL also reserves the right to increase or decrease the tendered quantities. Bidders should be prepared to accept order for reduced quantity without any extra charges.</p> <p>(b) Right of Rejection /Non- Placement of PO: BHEL reserves the right to accept the offers in part or in full or cancel the Tender enquiry/PO without assigning any reason.</p> <p>(c) Wherever BHEL business interest will contradict with any supplier, offer of that supplier may be rejected.</p>
35	<p>Integrity Commitment: The offers of the bidders who are under suspension as also the offers of the bidders, who engage the services of the banned firms, shall be rejected. The list of banned firms is available on BHEL website www.bhel.com. Integrity commitment, performance of the contract and punitive action thereof :</p>
A	<p>Commitment by BHEL : BHEL commits to take all measures necessary to prevent corruption in connection with the tender process and execution of the contract. BHEL will during the tender process treat all bidder's in a transparent and fair manner, and with equity.</p>
B	<p>Commitment by bidder / Supplier / Contractor :</p> <ul style="list-style-type: none"> - The bidder / supplier / contractor commit to take all measures to prevent corruption and will not directly or indirectly influence any decision or benefit which he is not legally entitled to nor will act or omit in any manner which tantamount to an offence punishable under any provision of the Indian Penal code, 1860 or any other law in force in India. - The bidder / supplier / contractor will, when presenting his bid, disclose any and all payments he has made, and is committed to or intends to make to agents, brokers or any other intermediaries in connection with the award of the contract and shall adhere to relevant guidelines issued from time to time by govt. of India / BHEL - The bidder / supplier / contractor will perform / execute the contract as per the contract terms & conditions and will not default without any reasonable cause, which causes loss of business / money / reputation to BHEL.
C	<p>If any bidder / supplier / contractor during pre-tendering / tendering / post tendering / award / execution / post execution stage indulges in mal-practices, cheating, bribery, fraud or / and other misconduct or formation of cartel so as to influence the bidding process or influence the price or acts or omits in any manner which tantamount to an offence punishable under any provision of the Indian Penal Code, 1860 or any other law in force in India, then action may be taken against such bidder / supplier / contractor as per the extant guidelines of the company available on www.bhel.com and / or under applicable legal provisions.</p>
d	<p>Defaulter suppliers shall be treated as per Guidelines for Suspension of the Business Dealing with suppliers/contractors.</p>
36	<p>Deviation: Any of the terms and conditions not acceptable to supplier, shall be explicitly mentioned in the tender. Otherwise, it will be treated as that all those terms and conditions as mentioned in the tender are acceptable in Toto.</p>
37	<p>Benefits earmarked to suppliers for Purchase under ' MAKE IN INDIA'</p>
	<p>Compliance to MAKE IN INDIA circular issued by GOI: "For this procurement, the local content to categorize a supplier as a Class I local supplier / Class II local supplier / Non-Local Supplier and purchase preference to Class I local supplier, is as defined in Public Procurement (Preference to Make in India), Order 2017 dated 04.06.2020 issued by DPIIT. In case of subsequent orders issued by the nodal ministry, changing the definition of local content for items of the NIT, the same shall be applicable even if issued after issue of this NIT, but before opening of Part II bids against this NIT" (Format Attached).</p>
	<p>As part of minimizing import content, Government of India, vide order no P-45021/2/2017-B.E.-II dated 15.06.2017, under the subject – Public Procurement (Preference to Make in India) -- has set the initiatives to encourage and promote indigenously manufactured goods within India and services provided by sources within India. . In line with this, bidders who manufacture the goods and provide services within India (otherwise referred as local suppliers) are given purchase preference and are entitled to benefits in the tender</p>
A	<p>Definitions</p>
(i)	<p>Local content means the amount of value added in India which shall, unless otherwise prescribed by the Nodal Ministry, be the total value of item procured (excluding net domestic indirect taxes) minus the value of imported content in the item (including all customs duties) as a proportion of the total value , in percent . Presently, the minimum local content required is</p>



GENERAL TERMS AND CONDITIONS OF ENQUIRY

GTC/FSIP/PUR/01 Rev:01

	50%. The nodal ministry may prescribe a higher or lower percentage in respect of any particular item and may also prescribe the manner of calculation of local content.
(ii)	Local supplier means a supplier or service provider whose product or service offered for procurement meets the minimum local content as prescribed
(iii)	Margin of Purchase Preference means the maximum extent to which the price quoted by a local supplier may be above the L1 for the purpose of purchase preference. Presently the margin of Purchase preference is 20%.
B	Conditions under which preference is given
(i)	In procurement of goods in respect of which the Nodal ministry has communicated that there is sufficient local capacity and local competition, and where the estimated value of procurement is Rs 50 lakhs or less, only local suppliers shall be eligible. If the estimated value of procurement of such goods is more than Rs 50 lakhs, provisions of 37(B) (ii) and 37(B)(iii) shall apply.
(ii)	If the procurement of goods are not covered by 37(B)(i) and are divisible in nature, the following procedure shall be followed :
a	If L1 is a local supplier, the order for full quantity shall be awarded to local supplier
b	If L1 bid is not from a local supplier, 50% of the order quantity shall be awarded to L1. Thereafter, the lowest bidder among the local suppliers, shall be invited to match the L1 price for the remaining 50% quantity, subject to the local supplier's quoted price falling within the margin of purchase preference, and the order for that quantity shall be awarded to such local supplier subject to matching the L1 price. In case such lowest eligible local supplier fails to match the L1 price or accepts less than offered quantity, the next higher local supplier within the margin of purchase preference shall be invited to match the L1 price for remaining quantity and so on, and the order shall be awarded accordingly. In case some quantity is still left uncovered on local suppliers, then such balance quantity may also be ordered on the L1 bidder.
iii	If the procurement of goods are not covered by 37(B)(ii) and are not divisible in nature, and in procurement of services where the bid is evaluated on the price alone, the following procedure shall be followed :
a	If L1 is a local supplier, the order shall be awarded to local supplier
b	If L1 bid is not from a local supplier, then the lowest bidder among the local suppliers, will be invited to match the L1 price, subject to the local supplier's quoted price falling within the margin of purchase preference, and the order shall be awarded to such local supplier subject to matching the L1 price. In case such lowest eligible local supplier fails to match the L1 price, the local supplier with the next higher bid within the margin of purchase preference shall be invited to match the L1 price and so on, and the order shall be awarded accordingly. In case none of the local suppliers within the margin of preference match the L1 price, then the order may be awarded to the L1 bidder.
C	Exemption of small purchases
	Notwithstanding anything contained at clause 37B above, procurements where the estimated value of procurement is less than Rs 5 lakhs are exempt and purchase preference shall not be accorded in such cases.
D	Verification of local content
(i)	The local supplier, at the time of tender, bidding or solicitation, shall be required to provide self-certification that the item offered meets the minimum local content and shall give details of the location(s) at which the local value addition is made.
(ii)	In cases of procurement for a value in excess of Rs 10 crores, the local supplier shall be required to provide a certificate from the statutory auditor or cost auditor of the company (in case of companies) or from a practicing cost accountant or practicing chartered accountant (in respect of suppliers other than companies) giving the percentage of local content.



GENERAL TERMS AND CONDITIONS OF ENQUIRY

GTC/FSIP/PUR/01 Rev:01

(iii)	False declarations shall be in breach of code of integrity and shall invite action as per guidelines for Suspension of Business dealings with Suppliers
E	In case of any disputes / clarifications, the extant guidelines of Government of India shall prevail.
38	Model Clauses for Tenders
I	Any bidder from a country which shares a land border with India will be eligible to bid in this tender only if the bidder is registered with the Competent Authority.
II	"Bidder" (including the term 'tenderer', 'consultant' or 'service provider' in certain contexts) means any person or firm or company, including any member of a consortium or joint venture (that is an association of several persons, or firms or companies), every artificial juridical person not falling in any of the descriptions of bidders stated hereinbefore, including any agency branch or office controlled by such person, participating in a procurement process.
III	"Bidder from a country which shares a land border with India" for the purpose of this Order means: -
a	An entity incorporated, established or registered in such a country; or
b	A subsidiary of an entity incorporated, established or registered in such a country; or
c	An entity substantially controlled through entities incorporated, established or registered in such a country; or
d	An entity whose beneficial owner is situated in such a country; or
e	An Indian (or other) agent of such an entity; or
f	A natural person who is a citizen of such a country; or
g	A consortium or joint venture where any member of the consortium or joint venture falls under any of the above
IV	The beneficial owner for the purpose of (iii) above will be as under:
1	In case of a company or limited liability Partnership, the beneficial owner is the natural person (s) who, whether acting alone or together, or through one or more juridical person, has a controlling ownership interest or who exercises control through other means. Explanation –
A	"Controlling ownership interest" means ownership of or entitlement to more than twenty-five per cent. Of shares or capital or profits of the company
B	"Control" shall include the right to appoint majority of the directors or to control the management or policy decisions including by virtue of their shareholding or management rights or shareholder's agreements of voting agreements;
2	In case of a partnership firm, the beneficial owner is the natural person (s) who, whether acting alone or together, or through one or more juridical of capital or profits of the partnership;
3	In case of an unincorporated association or body of individuals, the beneficial owner is the natural person (s), who, whether acting alone or together, or through one or more juridical person, has ownership of or entitlement to more than fifteen percent of the property of capital of profits of such association or body of individuals;
4	Where no natural person is identified under (1) or (2) or (3) above, the beneficial owner is the relevant natural person who holds the position of senior managing official;
5	In case of trust, the identification of beneficial owner (s) shall include identification of the author of the trust, the trustee, the beneficiaries with fifteen percent or more interest in the trust and any other natural person exercising ultimate effective control over the trust through a chain of control or ownership.
V	An agent is a person employed to do any act for another, or to represent another in dealings with third person.
39	Conciliation
	BHEL and bidder agree that if at any time (whether before, during or after the arbitral or judicial proceedings), any disputes (which term shall mean and include any dispute, difference, question or disagreement arising in connection with construction, meaning, operation, effect, interpretation or breach of the terms & conditions of order, which the parties are unable to settle mutually), arise inter-se the parties, the same may, be referred by either party to Conciliation to be



GENERAL TERMS AND CONDITIONS OF ENQUIRY

GTC/FSIP/PUR/01 Rev:01

	<p>conducted through Independent Experts Committee to be appointed by competent authority of BHEL from the BHEL panel of Conciliators</p> <p>Notes:</p> <ol style="list-style-type: none"> 1. No serving or a retired employee of BHEL/Administrative Ministry of BHEL shall be included in the BHEL Panel of Conciliators. 2. Any other person(s) can be appointed as Conciliator(s) who is/are mutually agreeable to both the parties from outside the BHEL Panel of Conciliators. <p>The proceedings of Conciliation shall broadly be governed by Part-III of the Arbitration and Conciliation Act 1996 or any statutory modification thereof. The details of Conciliations shall be governed by the BHEL Conciliation scheme 2018.</p>
40	Clause for Suspected Cartel Formation
	The Bidder declares that they will not enter into any illegal or undisclosed agreement or understanding, whether formal or informal with other Bidder(s). This applies in particular to prices, specifications, certifications, subsidiary contracts, submission or non-submission of bids or any other actions to restrict competitiveness or to introduce cartelization in the bidding process. In case, the Bidder is found having indulged in above activities, suitable action shall be taken by BHEL as per extant policies/ guidelines.
41	<i>Important Note: The bidder will, when presenting his bid, declare whether other family firms or sister concern affiliates/subsidiary firms are participating in same tender, so as to eliminate the possibility of cartel formation. Format for declaration is attached.</i>
42	Submission of Performance Security for execution of the contract
	Bidder agrees to submit performance security required for execution of the contract within the time period mentioned. In case of delay in submission of performance security, enhanced performance security which would include interest (SB/ rate + 6%) for the delayed period, shall be submitted by the bidder. Further, if performance security is not submitted till such time the first bill becomes due, the amount of performance security due shall be recovered as per terms defined in NIT I contract, from the bills along with due interest.
43	<u>If supplier does not mention against any terms of "General Terms and conditions", "Special/supplementary terms and conditions" and NIT terms. It shall be summarily concluded that respective terms are acceptable to supplier and no further clarification shall be asked.</u>

PREFERENCES/BENEFITS FOR MSEs:

Following preferences/benefits shall be given to MSEs in line with Public procurement policy for Micro and Small Enterprises (MSEs), 2012:

1. The tender documents shall be issued free of cost to MSEs.
2. MSEs are exempted from payment of Earnest Money Deposit (EMD).
3. In tender, Micro and Small Enterprises quoting within the price band of L1+15% shall be allowed to supply the requirement up to 25% of the tender quantity subject to condition that such Enterprises bring down their price to L1 price where L1 price is from other than a Micro and Small Enterprise. If L1 offer is from a Micro / Small Enterprise, this provision will not be applicable. In case more than one Micro and Small Enterprise is there within this span, the supply shall be shared proportionately to the tender quantity. For availing the advantage of L1+15%, bidder to provide the MSME certificate prior to price bid opening.

Under above following provision is categorised as below:

- **Special provision for Micro and small enterprises owned by SC or ST: -**

Sub target of 25% (i.e. 6.25% out of 25%) would be earmarked for procurement from Micro and Small Enterprises owned by the Scheduled Caste or Scheduled Tribe Entrepreneurs provided that in event of failure of such Micro and Small Enterprises to participate in the tender process or meet the tender requirements and the L1 price, the 6.25% sub-target for procurement ear-marked MSE owned by Scheduled Caste or Scheduled Tribe Entrepreneurs shall be met from other MSE Enterprises.

- **Special provision for Micro and small enterprises owned by Women in following cases: - 3% reservation for women owned MSEs under following conditions**
 - i. In case of Proprietary MSE, proprietor is woman.
 - ii. In case of partnership MSE, the woman partner is holding at least 51% share in the unit.
 - iii. In case private limited companies, at least 51% share is held by woman promoters.

MSE suppliers can avail the intended benefits only if they submit along with offer, attested copies of either EM-II certificate having deemed validity (Five years from date of issue of acknowledgement in EM-II) or valid NSIC certificate/ DIC certificate/ Udyog aadhar or EM-II certificate along with attested copy of a CA certificate (format enclosed as per annexure-I where deemed validity of EM-II certificate of 5 years has expired) applicable for the relevant financial year (latest audited). Date to be reckoned for determining the deemed validity will be the date of bid opening (part-I in case of two part bid). Non submission of such documents will lead to consideration of their bids at par with other bidders. MSE status of such suppliers shall be shifted to non MSE supplier till the supplier submits the documents. This provision for MSE will apply subject to the condition that the participating MSE meets the tender requirements.

ANNEXURE- I

Certificate by Chartered Accountant on Letter Head

This is to Certify that M/s.
(Hereinafter
 referred to as 'company') having its registered office at
is registered under MSMED Act 2006, (Entrepreneur Memorandum
 No (Part-IIdated: Category:
 (Micro/Small) (Copy enclosed).

Further verified from the Books of Accounts that the investment of the company as on date as per
 MSMED Act 2006 is as follows:

I. For Manufacturing Enterprises: Investment in plant and machinery (i.e. original cost excluding land and
 building and the items specified by the Ministry of Small Scale Industries vide its notification
 No.S.O.1722(E) dated October 5, 2006 :

Rs.Lacs

2. For Service Enterprises: Investment in equipment (original cost excluding land and building and furniture,
 fittings and other items not directly related to the service rendered or as may be notified under the MSMED Act,
 2006:

RsLacs

(Strike off whichever is not applicable)

The above investment of Rs. Lacs is within permissible limit of Rs. -----Lacs for
 Micro/Small (Strike off which is not applicable) Category under MSMED Act 2006.

Or

The company has been graduated from its original category (Micro/ Small) (Strike off which is not applicable)
 and the date of graduation of such enterprise from its original category is -----(dd/mm/yyyy) which is
 within the period of 3 years from the date of graduation of such enterprise from its original category as notified
 vide S.O. No. 3322(E) dated 01.11.2013 published in the gazette notification dated 04.11.2013 by Ministry of
 MSME.

Date:

(Signature)

Name -

Membership number -

Seal of Chartered Accountant

DECLARATION BY VENDOR

We declare that the following family firms or sister concern affiliates/subsidiary firms are participating in the tender No

1.

2.

3.

.....

I, hereby declare on behalf of M/s and the family firms or sister concern affiliates/subsidiary firms listed above that we are not indulging in cartel formation for enquiry No

(.....)

For M/s

(Seal & Sign)

Self-Declaration on Class I/Class II/Non Local under Make in India
(Valid for tender value greater than or equal to 5 Lakhs and Less than or equal to 10 Crores)

I, hereby declare on behalf of M/s that my firm is under Class I ()/Class II ()/Non Local () as per Make in India Government Preferences.

(.....)

For M/s

(Seal & Sign)

Annexure-1

INTEGRITY PACT**Between**

Bharat Heavy Electricals Ltd. (BHEL), a company registered under the Companies Act 1956 and having its registered office at "BHEL House", Siri Fort, New Delhi - 110049 (India) hereinafter referred to as "The Principal", which expression unless repugnant to the context or meaning hereof shall include its successors or assigns of the ONE PART

and

_____, (description of the party along with address), hereinafter referred to as "The Bidder/ Contractor" which expression unless repugnant to the context or meaning hereof shall include its successors or assigns of the OTHER PART

Preamble

The Principal intends to award, under laid-down organizational procedures, contract/s for Supply of CRNGO against T.E. No:- 2200095, dt: 20/12/2022 _____ (hereinafter referred to as "Contract"). The Principal values full compliance with all relevant laws of the land, rules and regulations, and the principles of economic use of resources, and of fairness and transparency in its relations with its Bidder(s)/ Contractor(s).

In order to achieve these goals, the Principal will appoint panel of Independent External Monitor(s) (IEMs), who will monitor the tender process and the execution of the contract for compliance with the principles mentioned above.

Section 1- Commitments of the Principal

- 1.1 The Principal commits itself to take all measures necessary to prevent corruption and to observe the following principles: -
 - 1.1.1 No employee of the Principal, personally or through family members, will in connection with the tender for, or the execution of a contract, demand, take a promise for or accept, for self or third person, any material or immaterial benefit which the person is not legally entitled to.
 - 1.1.2 The Principal will, during the tender process treat all Bidder(s) with equity and reason. The Principal will in particular, before and during the tender process, provide to all Bidder(s) the same information and will not provide to any Bidder(s) confidential/ additional information through which the Bidder(s) could obtain an advantage in relation to the tender process or the contract execution.
 - 1.1.3 The Principal will exclude from the process all known prejudiced persons.
- 1.2 If the Principal obtains information on the conduct of any of its employees which is a penal offence under the Indian Penal Code 1860 and Prevention of Corruption Act 1988 or any other statutory penal enactment, or if there be a substantive suspicion in this regard, the Principal will inform its Vigilance Office and in addition can initiate disciplinary actions.

Section 2 - Commitments of the Bidder(s)/ Contractor(s)

- 2.1 The Bidder(s)/ Contractor(s) commit himself to take all measures necessary to prevent corruption. The Bidder(s)/ Contractor(s) commits himself to observe the following principles during participation in the tender process and during the contract execution.

BHEL-IP

AA:SSP:IP:R03 dtd 01-04-2022

- 2.1.1 The Bidder(s)/ Contractor(s) will not, directly or through any other person or firm, offer, promise or give to the Principal or to any of the Principal's employees involved in the tender process or the execution of the contract or to any third person any material, immaterial or any other benefit which he/ she is not legally entitled to, in order to obtain in exchange any advantage of any kind whatsoever during the tender process or during the execution of the contract.
- 2.1.2 The Bidder(s)/ Contractor(s) will not enter with other Bidder(s) into any illegal or undisclosed agreement or understanding, whether formal or informal. This applies in particular to prices, specifications, certifications, subsidiary contracts, submission or non-submission of bids or any other actions to restrict competitiveness or to introduce cartelization in the bidding process.
- 2.1.3 The Bidder(s)/ Contractor(s) will not commit any penal offence under the relevant Indian Penal Code (IPC) and Prevention of Corruption Act; further the Bidder(s)/ Contractor(s) will not use improperly, for purposes of competition or personal gain, or pass on to others, any information or document provided by the Principal as part of the business relationship, regarding plans, technical proposals and business details, including information contained or transmitted electronically.
- 2.1.4 Foreign Bidder(s)/ Contractor(s) shall disclose the name and address of agents and representatives in India and Indian Bidder(s)/ Contractor(s) to disclose their foreign principals or associates. The Bidder(s)/ Contractor(s) will, when presenting his bid, disclose any and all payments he has made, and is committed to or intends to make to agents, brokers or any other intermediaries in connection with the award of the contract.
- 2.2 The Bidder(s)/ Contractor(s) will not instigate third persons to commit offences outlined above or be an accessory to such offences.
- 2.3 The Bidder(s)/ Contractor(s) shall not approach the Courts while representing the matters to IEMs and shall await their decision in the matter.

Section 3 - Disqualification from tender process and exclusion from future contracts

If the Bidder(s)/ Contractor(s), before award or during execution has committed a transgression through a violation of Section 2 above, or acts in any other manner such as to put his reliability or credibility in question, the Principal is entitled to disqualify the Bidder(s)/ Contractor(s) from the tender process, terminate the contract, if already awarded, exclude from future business dealings and/ or take action as per the separate "Guidelines on Banning of Business dealings with Suppliers/ Contractors", framed by the Principal.

Section 4 - Compensation for Damages

- 4.1 If the Principal has disqualified the Bidder (s) from the tender process before award / order acceptance according to Section 3, the Principal is entitled to demand and recover the damages equivalent to Earnest Money Deposit/ Bid Security.
- 4.2 If the Principal is entitled to terminate the Contract according to Section 3, or terminates the Contract in application of Section 3 above, the Bidder(s)/ Contractor (s) transgression through a violation of Section 2 above shall be construed breach of contract and the Principal shall be entitled to demand and recover from the Contractor an amount equal to 5% of the contract value or the amount equivalent to Security Deposit/ Performance Bank Guarantee, whichever is higher, as damages, in addition to and without prejudice to its right to demand and recover compensation for any other loss or damages specified elsewhere in the contract.

Section 5 - Previous Transgression

- 5.1 The Bidder declares that no previous transgressions occurred in the last 3 (three) years with any other company in any country conforming to the anti-corruption approach or with any other Public Sector Enterprise in India that could justify his exclusion from the tender process.
- 5.2 If the Bidder makes incorrect statement on this subject, he can be disqualified from the tender process or the contract, if already awarded, can be terminated for such reason or action can be taken as per the separate "Guidelines on Banning of Business dealings with Suppliers/ Contractors", framed by the Principal.

Section 6 - Equal treatment of all Bidder (s)/ Contractor (s) / Sub-contractor (s)

- 6.1 The Principal will enter into Integrity Pacts with identical conditions as this Integrity Pact with all Bidders and Contractors.
- 6.2 In case of Sub-contracting, the Principal Contractor shall take the responsibility of the adoption of Integrity Pact by the Sub-contractor(s) and ensure that all Sub-contractors also sign the Integrity Pact.
- 6.3 The Principal will disqualify from the tender process all Bidders who do not sign this Integrity Pact or violate its provisions.

Section 7 - Criminal Charges against violating Bidders/ Contractors /Subcontractors

If the Principal obtains knowledge of conduct of a Bidder, Contractor or Subcontractor, or of an employee or a representative or an associate of a Bidder, Contractor or Subcontractor which constitutes corruption, or if the Principal has substantive suspicion in this regard, the Principal will inform the Vigilance Office.

Section 8 -Independent External Monitor(s)

- 8.1 The Principal appoints competent and credible panel of Independent External Monitor (s) (IEMs) for this Integrity Pact. The task of the IEMs is to review independently and objectively, whether and to what extent the parties comply with the obligations under this Integrity Pact.
- 8.2 The IEMs are not subject to instructions by the representatives of the parties and performs his functions neutrally and independently. He reports to the CMD, BHEL.
- 8.3 The IEMs shall be provided access to all documents/ records pertaining to the Contract, for which a complaint or issue is raised before them as and when warranted. However, the documents/records/information having National Security implications and those documents which have been classified as Secret/Top Secret are not to be disclosed.
- 8.4 The Principal will provide to the IEMs sufficient information about all meetings among the parties related to the Contract provided such meetings could have an impact on the contractual relations between the Principal and the Contractor. The parties offer to the IEMs the option to participate in such meetings.

BHEL-IP

AA:SSP:IP:R03 dtd 01-04-2022

- 8.5 The advisory role of IEMs is envisaged as that of a friend, philosopher and guide. The advice of IEMs would not be legally binding and it is restricted to resolving issues raised by a Bidder regarding any aspect of the tender which allegedly restricts competition or bias towards some Bidders. At the same time, it must be understood that IEMs are not consultants to the Management. Their role is independent in nature and the advice once tendered would not be subject to review at the request of the organization.
- 8.6 For ensuring the desired transparency and objectivity in dealing with the complaints arising out of any tendering process or during execution of Contract, the matter should be examined by the full panel of IEMs jointly, who would look into the records, conduct an investigation, and submit their joint recommendations to the Management.
- 8.7 The IEMs would examine all complaints received by them and give their recommendations/ views to the CMD, BHEL at the earliest. They may also send their report directly to the CVO, in case of suspicion of serious irregularities requiring legal/ administrative action. Only in case of very serious issue having a specific, verifiable Vigilance angle, the matter should be reported directly to the Commission. IEMs will tender their advice on the complaints within 30 days.
- 8.8 The CMD, BHEL shall decide the compensation to be paid to the IEMs and its terms and conditions.
- 8.9 IEMs should examine the process integrity, they are not expected to concern themselves with fixing of responsibility of officers. Complaints alleging mala fide on the part of any officer of the Principal should be looked into by the CVO of the Principal.
- 8.10 If the IEMs have reported to the CMD, BHEL, a substantiated suspicion of an offence under relevant Indian Penal Code / Prevention of Corruption Act, and the CMD, BHEL has not, within reasonable time, taken visible action to proceed against such offence or reported it to the Vigilance Office, the IEMs may also transmit this information directly to the Central Vigilance Commissioner, Government of India.
- 8.11 After award of work, the IEMs shall look into any issue relating to execution of Contract, if specifically raised before them. As an illustrative example, if a Contractor who has been awarded the Contract, during the execution of Contract, raises issue of delayed payment etc. before the IEMs, the same shall be examined by the panel of IEMs. Issues like warranty/ guarantee etc. shall be outside the purview of IEMs.
- 8.12 However, the IEMs may suggest systemic improvements to the management of the Principal, if considered necessary, to bring about transparency, equity and fairness in the system of procurement.
- 8.13 The word 'Monitor' would include both singular and plural.

Section 9 - Pact Duration

- 9.1 This Integrity Pact shall be operative from the date this Integrity Pact is signed by both the parties till the final completion of contract for successful Bidder, and for all other Bidders 6 months after the Contract has been awarded. Any violation of the same would entail disqualification of the bidders and exclusion from future business dealings.
- 9.2 If any claim is made/ lodged during currency of this Integrity Pact, the same shall be binding and continue to be valid despite the lapse of this Pact as specified above, unless it is discharged/ determined by the CMD, BHEL.

Section 10 - Other Provisions

- 10.1 This Integrity Pact is subject to Indian Laws and exclusive jurisdiction shall be of the competent Courts as indicated in the Tender or Contract, as the case may be.
- 10.2 Changes and supplements as well as termination notices need to be made in writing.
- 10.3 If the Bidder(s)/ Contractor(s) is a partnership or a consortium or a joint venture, this Integrity Pact shall be signed by all partners of the partnership or joint venture or all consortium members.
- 10.4 Should one or several provisions of this Integrity Pact turn out to be invalid, the remainder of this Integrity Pact remains valid. In this case, the parties will strive to come to an agreement to their original intentions.
- 10.5 Only those bidders / contractors who have entered into this Integrity Pact with the Principal would be competent to participate in the bidding. In other words, entering into this Integrity Pact would be a preliminary qualification.
- 10.6 In the event of any dispute between the Principal and Bidder(s)/ Contractor(s) relating to the Contract, in case, both the parties are agreeable, they may try to settle dispute through Mediation before the panel of IEMs in a time bound manner. In case, the dispute remains unresolved even after mediation by the panel of IEMs, either party may take further action as the terms & conditions of the Contract. The fees/expenses on dispute resolution through mediation shall be shared by both the parties. Further, the mediation proceedings shall be confidential in nature and the parties shall keep confidential all matters relating to the mediation proceedings including any settlement agreement arrived at between the parties as outcome of mediation. Any views expressed, suggestions, admissions or proposals etc. made by either party in the course of mediation shall not be relied upon or introduced as evidence in any further arbitral or judicial proceedings, whether or not such proceedings relate to the dispute that is the subject of mediation proceedings. Neither of the parties shall present IEMs as witness in any Alternative Dispute Resolution or judicial proceedings in respect of the dispute that was subject of mediation.

Mannesh
 For & On behalf of the Principal
 (Office Seal)
 By *MANNESH KUMAR*
 Jager
 BHEL FSIP, Jagdishpur-Amethi
 Place Jagdishpur
 Date 20/12/2022

Witness: *Rennish*
 (Name & Address) P. K. Mishra
M M FSIP Jagdishpur

 For & On behalf of the Bidder/ Contractor
 (Office Seal)

Witness: _____
 (Name & Address) _____

Clause on IP in the tender**Integrity Pact (IP)**

- (a) IP is a tool to ensure that activities and transactions between the Company and its Bidders/ Contractors are handled in a fair, transparent and corruption free manner. Following Independent External Monitors (IEMs) on the present panel have been appointed by BHEL with the approval of CVC to oversee implementation of IP in BHEL.

SI	IEM	Email
1.	Shri Otem Dai, IAS (Retd.)	iem1@bhel.in
2.	Shri Bishwamitra Pandey, IRAS (Retd.)	iem2@bhel.in
3.	Shri Mukesh Mittal, IRS (Retd.)	iem3@bhel.in

- (b) The IP as enclosed with the tender is to be submitted (duly signed by authorized signatory) along with techno-commercial bid (Part-I, in case of two/ three part bid). Only those bidders who have entered into such an IP with BHEL would be competent to participate in the bidding. In other words, entering into this Pact would be a preliminary qualification.
- (c) Please refer Section-8 of IP for Role and Responsibilities of IEMs. In case of any complaint arising out of the tendering process, the matter may be referred to any of the above IEM(s). All correspondence with the IEMs shall be done through email only.

Note:

No routine correspondence shall be addressed to the IEM (phone/ post/ email) regarding the clarifications, time extensions or any other administrative queries, etc on the tender issued. All such clarification/ issues shall be addressed directly to the tender issuing (procurement) department's officials whose contact details are provided below:

Details of contact person(s):

(1)
 Name: Manmeet Kumar
 Deptt: MM
 Address: FSIP, Jagdishpur
 Phone: (Landline/ Mobile)
8427978877
 Email: manmeet@bhel.in
 Fax: _____

(2)
 Name: N. A. Saifi
 Deptt: MM
 Address: FSIP Jagdishpur
 Phone: (Landline/ Mobile)
7318492175
 Email: nasai@bhel.in
 Fax: _____



TME 2011

**PRODUCT STANDARD
TME DIVISION, BHOPAL****TM 10472****Rev 04****PAGE 01 OF 10****SPECIFICATION FOR COLD ROLLED NON- GRAIN ORIENTED (CRNO) ELECTRICAL STEEL SHEET / STRIP FOR MANUFACTURE OF 3-PHASE TRACTION MOTOR TYPE 6FRA6068 & 6FXA7059****1.0 SCOPE:**

This specification governs the quality requirements of insulated (double side) unpigmented type cold rolled, non-grain oriented magnetic steel sheet or coil in finally annealed condition in 0.50 mm thickness.

2.0 APPLICATION:



Laminations of Electrical Machines.

3.0 RAW MATERIAL :

3.1 The material should be Insulated (double side) unpigmented type Cold Rolled Non-Grain Oriented, Finally Annealed steel sheet of either of the following Grades.

- i) Grade V 530-50A to DIN 46400 Pt-I with C4/C6 coating (with minimum average 4 microns coating thickness on each side, Total 8 micros) (German origin)
- ii) Gr. M530-50A to EN-10106 with C4/C6 Coating (with minimum average 4 microns coating thickness on each side, Total 8 microns (European origin).
- iii) Gr. M530-50A with C4/C6 Coating (with minimum average 4 microns coating thickness on each side, Total 8 microns) to IEC: 60404-8-4.
- iv) M/s Thyssen Krupp Electrical Steel India Pvt. Ltd Grade 50C 530/C6A of C3Y type (with minimum average of 4 microns coating thickness on each side, Total 8 microns) to IS:648 & IS 649.
- v) SAIL material Grade 50C 530 to IS: 648 with C3 coating with special imported varnish of M/s REMBRANDTIN / Austria Brand- REMISOL EB-5001 with minimum average of 4 microns coating thickness on each side (total 8 microns). This core plate varnish C6 (C3 Pigmented) shall be water reduceable, pigmented, Chromium free. Thermally resistant Phenolic Resins.
- vi) M/s JSW Steel Ltd. CRNO electrical steel Gr. 50C530 to IS:648 with C6 coating manufactured by using imported varnish of M/s REMBRANDTIN/Austria or M/s Dorf Ketel Chemicals India Pvt. Ltd./ Mumbai.
- vii) M/s POSCO India/ Pune CRNO electrical sheel Steel Gr. M530-50A to IEC: 60404-8-4 with C6/C3 coating manufactured at their OEM's Pohang Plant/ Korea by using varnish of M/s A.K. Chemtech/ Korea.
- viii) M/s SAIL make CRNO electrical steel sheet Gr. 50C530 to IS:648 with C6 coating manufactured by using varnish of M/s Drof Ketel Chemicals India Pvt. Ltd./ Mumbai
- ix) CRNO electrical Steel Sheet duly coated from existing and other steel manufacturers confirming to any of the above grade and having surface insulation resistance more than $50 \Omega/\text{cm}^2$ lamination are also acceptable. Tender should furnish make and other details along with technical leaflet. MTC from OEM (Steel Manufacturers) to be submitted along with supply.

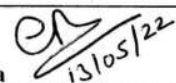
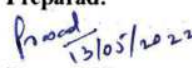
COPYRIGHT AND CONFIDENTIAL
The information on this document is the property of **BHARAT HEAVY ELECTRICALS LIMITED**
It must not be used directly or indirectly in any way detrimental to the interest of

Revision: 04 Date: 13/05/2022	Distribution	Qty.	Approved:  13/05/22		
	TME PRM TXM QFD	1 1 1 1	Prepared:  13/05/2022 Prasad Telang	Checked:  Kunal Dugvekar	Date: 13/05/2022



TME 2011

PRODUCT STANDARD
TME DIVISION, BHOPAL

TM 10472

Rev 04

PAGE 02 OF 10

4.0 DIMENSIONS AND TOLERANCES:

4.1 Sizes:

Magnetic steel sheet shall be supplied to the dimensions specified on BHEL order.

4.2 Tolerances:

4.2.1 Thickness:

The permissible deviation in nominal thickness shall be $\pm 8\%$. The variation in thickness in a direction parallel to the direction of rolling shall not exceed $\pm 8\%$ of the nominal thickness.

The variation in thickness in a direction perpendicular to the direction of rolling shall be ± 0.020 mm for a nominal thickness of 0.50mm. The measuring points should be at least 40 mm away from the edges of the sheets.

4.2.2 Width:

The tolerance for width of material supplied with trimmed edges shall be as follows:

Width (mm)		Tolerance (mm)	
Over	Upto & incl.	Plus	Minus
-	150	0.3	0
150	500	0.5	0
500	1250	1.5	0

4.2.3 Length:

When supplied in sheet form the tolerance on length shall be + 1%, but shall not exceed + 10mm, -0.

4.2.4 Straightness/Edge camber

The straightness tolerances for the longitudinal edge (edge camber) over a gauge length of 2000 mm shall not exceed 4 mm for width upto and including 150mm and 2mm for widths exceeding 150mm.

COPYRIGHT AND CONFIDENTIAL
The information on this document is the property of **BHARAT HEAVY ELECTRICALS LIMITED**
It must not be used directly or indirectly in any way detrimental to the interest of the company



TME 2011

PRODUCT STANDARD
TME DIVISION, BHOPAL

TM 10472

Rev 04

PAGE 03 OF 10

COPYRIGHT AND CONFIDENTIAL
The information on this document is the property of **BHARAT HEAVY ELECTRICALS LIMITED**
It must not be used directly or indirectly in any way detrimental to the interest of the company

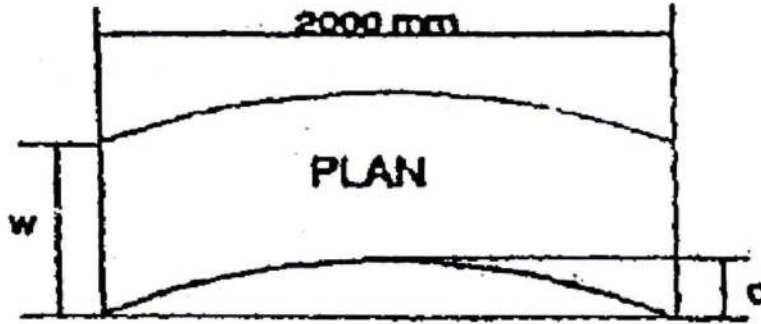

W = Width of Strip
C = Edge Camber

4.2.5 Edge Burr:

The height of edge burr shall not exceed 50 microns.

4.2.6 Bowing - Coils:

The material when unwound from a coil shall be placed flat on a level smooth surface (surface plate) such that it has a radius not less than 3000 mm. The specimen should be stood upright and free from constraint with one longitudinal edge on the surface of the plate. A straight edge with a length of 500 mm, when placed against the specimen and when measuring the greatest distance *h' between the straight edge and the product should not be more than 10 mm as detailed below:

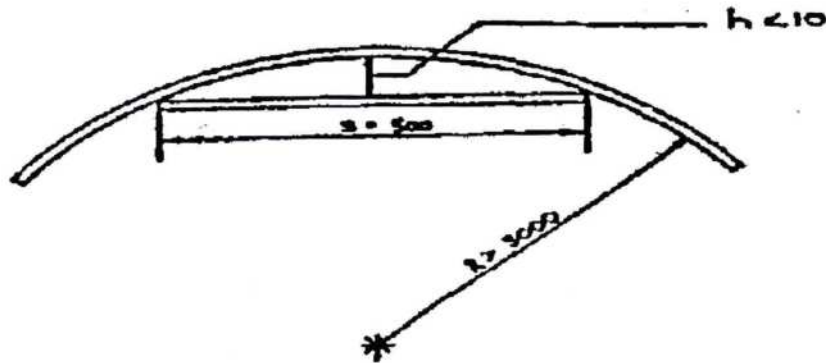



TME 2011

PRODUCT STANDARD
TME DIVISION, BHOPAL

TM 10472

Rev 04

PAGE 04 OF 10

COPYRIGHT AND CONFIDENTIAL
The information on this document is the property of **BHARAT HEAVY ELECTRICALS LIMITED**
It must not be used directly or indirectly in any way detrimental to the interest of the company

4.2.7 Waviness/Flatness

The Waviness/Flatness shall not exceed 1.5% (i.e the ratio of the wave height to wave length).

5.0 FINISH:

The material shall have a smooth surface and shall be free from loose scale, buckle or dents, waviness and internal stresses.

6.0 TEST SAMPLES:

The test samples of the same heat/melt & thickness shall be selected from the consignment as follows:

Up to 30 tonnes	: 1 sample
Above 30 to 60 tonnes	: 2 samples
Above 60 tonnes	: 3 samples

The test samples shall be sufficient in size to provide the necessary test pieces.

7.0 ACCEPTANCE TEST:

7.1 Bend Test :

A test piece taken in rolling direction in the ordered thickness shall withstand a minimum of 10 bends, without fracture through 180 deg. Over a 5 mm radius jaws when tested to IS:649.

7.2 Stacking Factor:

The surface quality of the sheets when measured in terms of stacking factor as per IS649 shall not be less be 95%.

7.3 Total Specific Loss:

The specific total loss on aged specimens (A specimen which has been heated for 24 Hrs. at 225 deg. for 0.50 mm thickness) when tested as per IS:649 at frequency 50Hz and 1.5 Tesla should not exceed 5.30 W/Kg.

7.4 AC Magnetization:

When tested to IS:649, the AC magnetic field (H) in Ampere/meter (Peak) shall show the following minimum corresponding values of magnetic induction (B) in Tesla (Peak) for 0.50 mm thick material.



TME 2011

PRODUCT STANDARD
TME DIVISION, BHOPAL

TM 10472

Rev 04

PAGE 05 OF 10

AC magnetic Field Strength 'H' A/m Magnetic Induction, Min (B) Tesla (Peak)

2500 AT/M	1.54
5000 AT/M	1.64
10000 AT/M	1.74

7.5 Anisotropy of losses:

When tested to IS:649 the Anisotropy losses shall not exceed $\pm 10\%$.

7.6 Testing of insulation Coating:

The insulation coating when tested as detailed below shall show following properties.

7.6.1 Selection of Test Samples for Insulation Coating :

The outermost and innermost turn of coil or the top-most and bottom most of a stack of sheets, shall be considered as wrapping and not representing the properties of the remaining material and hence shall not be considered for test specimen. In case of coils, the test specimens shall preferably be taken from the first external turn excluding the wrapping turn and in case of sheet, it shall be from the upper part of the stack. In special case, it can be taken from any other part also. The surface of the strip shall be free from contaminations and damages and shall be cut without deformation and as far as possible, without burrs. Any cleaning done shall not damage the insulation coating.

7.6.2 Coating Layer Thickness :

Both sides of the sheet shall be coated and shall have a thickness of 4 to 7 microns on each side at least 15 readings shall be taken on each side at equal intervals.

7.6.3 Surface Insulation Resistivity :

To be tested as per test procedure mentioned in relevant standard.

7.6.4 Type Tests*: In addition to tests specified at 7.1 to 7.6.3.

7.6.4.1 Adherence Test :

The surface coating shall be sufficiently adherent so that it does not get detached during insulation and shearing. In the reverse bending test with the bending radius of 5 mm the surface coating shall not be detached after bending through 90 deg.

7.6.4.2 Thermal Effect on coating :

Twelve specimen of the coated strip shall be clamped together under a pressure of 1 N/mm² approximately and fitted in the laboratory oven at a temperature specified in relevant Standards for a period specified in relevant Standards. After cooling to the room temperature, the surface insulation resistivity values of the middle ten specimens shall not be less than the minimum specified values mentioned in relevant Standards.

COPYRIGHT AND CONFIDENTIAL
The information on this document is the property of BHARAT HEAVY ELECTRICALS LIMITED
It must not be used directly or indirectly in any way detrimental to the interest of the company



TME 2011

**PRODUCT STANDARD
TME DIVISION, BHOPAL**

TM 10472

Rev 04

PAGE 06 OF 10

7.6.4.3 Resistance to solvents Oils :

The specimen shall be kept in a container filled with boiling Trichloroethylene or xylene for 5 minutes. After removal and cooling to the room temperature, the coating shall not get soft enough so that it can be wiped off.

***Note :**

'Type tests', shall be carried out when, 'Type Approval' to a supplier is given and repeated once in Five years for the approved supplier.

8.0 TEST CERTIFICATES:

Three copies of test certificates shall be supplied, unless otherwise specified on order. In addition, the supplier shall ensure to enclose one copy of the test certificate along with their dispatch documents to facilitate quick clearance of the material.

The test certificate shall bear the following information:

TM10472 Rev No, BHEL Order No, Supplier's Name/Grade/Identification No., Size & Weight, Melt No., Packet/ Bundle No. Test results of Dimensions & Tolerances and Properties as per the concerned National standards & Insulation coating, as above.

9.0 SURFACE QUALITY OF STEEL SHEETS USED :

9.1 The surface of the Steel sheets used shall be smooth and bright as further treatment and processing must not result in any burrs or uneven spots of thickness more than 0.02 mm.

9.2 The sheets must be easy to cut without bending and should not result in premature wear on the cutting tools.

10.0 SURFACE COATING (INSULATION) :

10.1 Thickness of the surface coating on both sides shall be maintained at 4 µm (minimum) total 8 microns to be measured as per IS:649 Surface coating must have adhesive properties to withstand cutting and bending operations surface coating should be able to withstand a minimum of 10 bends of 90° with a bending radius of 5 mm without any damages in the surface coating. If this trial fails the Stampings has to undergo a factory cutting test.

COPYRIGHT AND CONFIDENTIAL
The information on this document is the property of BHARAT HEAVY ELECTRICALS LIMITED
It must not be used directly or indirectly in any way detrimental to the interest of the company



TME 2011

PRODUCT STANDARD
TME DIVISION, BHOPAL

TM 10472

Rev 04

PAGE 07 OF 10

11.0 PACKING AND MARKING:

11.1 Material Supplied in Straight Length:

Magnetic steel sheets shall be supplied in bundles. The packing shall be seaworthy and shall protect the material from damage in transit. A typical packing which would be suitable is shown below.

Each sheet shall be marked with supplier's grade/references.

These markings shall be along the rolling direction.

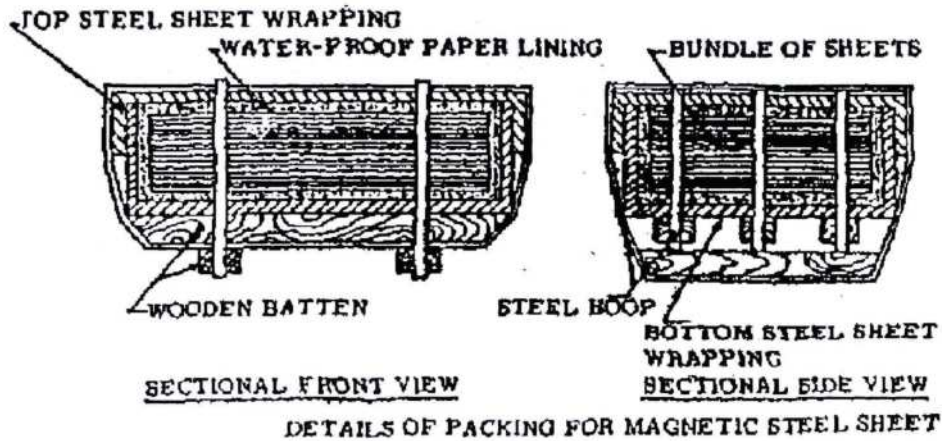

Note:

- a) Water proof paper lining shall be preferably Volatile Corrosion Inhibitor (V.C.I.) Coated Paper with an additional polythene (100 micron) enveloped.
- b) Approximate weight of each bundle shall be 2 to 3 metric tonnes. Bundle weighing 2 Metric tonnes is however preferred.
- c) The packing should ensure that there is no seepage of moisture and the sheets reach BHEL on completely rust free condition. It shall be strong enough to withstand handling at the docks, at sea and on the road.
- d) Mark/ Grade as well as name of OEM must be printed on Electrical sheet steel at a distance not more than 500 mm apart from each other.

11.2 Material Supplied In Continuous Coil:

The nominal weight of each coil shall be 1800-2000kg.

The nominal internal diameter of coil shall be 508 mm.

Packing shall be sea-worthy and shall protect the coils from damage and rusting during transit. The supplier's grade/reference shall be marked at every one meter intervals throughout the coil length.



TME 2011

PRODUCT STANDARD
TME DIVISION, BHOPAL

TM 10472

Rev 04

PAGE 08 OF 10

COPYRIGHT AND CONFIDENTIAL
The information on this document is the property of BHARAT HEAVY ELECTRICALS LIMITED
It must not be used directly or indirectly in any way detrimental to the interest of the company

Coils shall be vertically packed according to the instructions and drawing given below:

- a) An annular protection board shall be placed at either end of the coil.
- b) The coil shall then be wrapped with waterproof anti-rust proof paper by lapping axially all around the circumference.
- c) The coil shall then be covered by polyethylene sheet or anti-rust waterproof paper and the ends sealed properly.
- d) A galvanized sheet shall be wrapped on the outside of the coil and the top and bottom of the coils. Care shall be taken to ensure that the ends of the top and bottom of the coils extend sufficiently over the inside diameter of the coil.
- e) A galvanized sheet shall be wrapped on the inside of the coil. Care shall be taken that it overlaps sufficiently over the ends of the sheet mentioned in (d) above.
- f) Steel ring made from thick angle sheets shall be placed on the rim of the inner diameter at both ends of the coil. The rings shall be held at either ends at four points by steel bands.
- g) The coil should then be mounted on wooden skids held together by steel bands. Wooden skids must have cutouts to house the steel bands for tight fit and to avoid slippage.
- h) The packing shall ensure that there is no seepage of moisture and the coils reach BHEL in completely rust free condition. It shall be strong enough to withstand handling at the docks, at sea and on the road.
- i) Coils shall be sufficiently tight-wound to prevent collapse to an extent that would preclude their being mounted on a mandrel appropriate to the ordered internal diameter.
- j) Each package should indicate the, Sling Position, for lifting without damage. It is preferable to fix a suitable size of, 'Sheet Steel Angle', at the position where the Sling Rope is to be fitted to avoid slippage/damage/breakage of the wooden skid at four places.



PRODUCT STANDARD
TME DIVISION, BHOPAL

TM 10472

TME 2011

Rev 04

PAGE 09 OF 10

COPYRIGHT AND CONFIDENTIAL
The information on this document is the property of **BHARAT HEAVY ELECTRICALS LIMITED**
It must not be used directly or indirectly in any way detrimental to the interest of the company

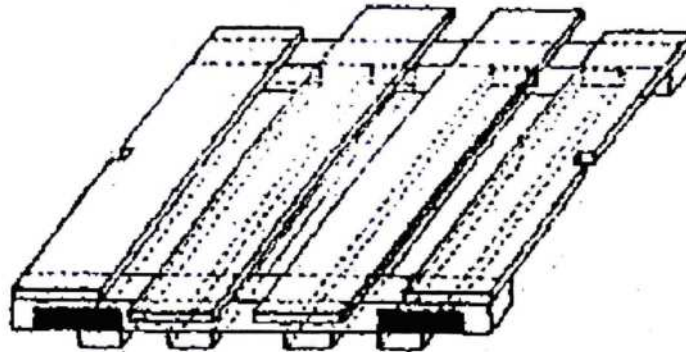
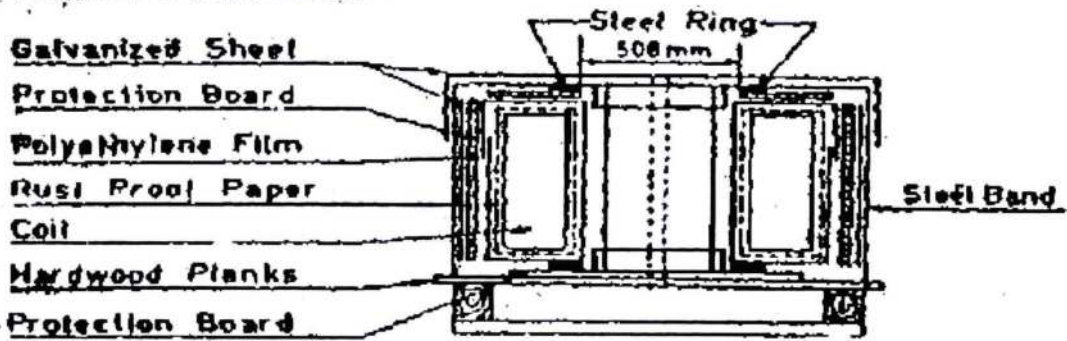
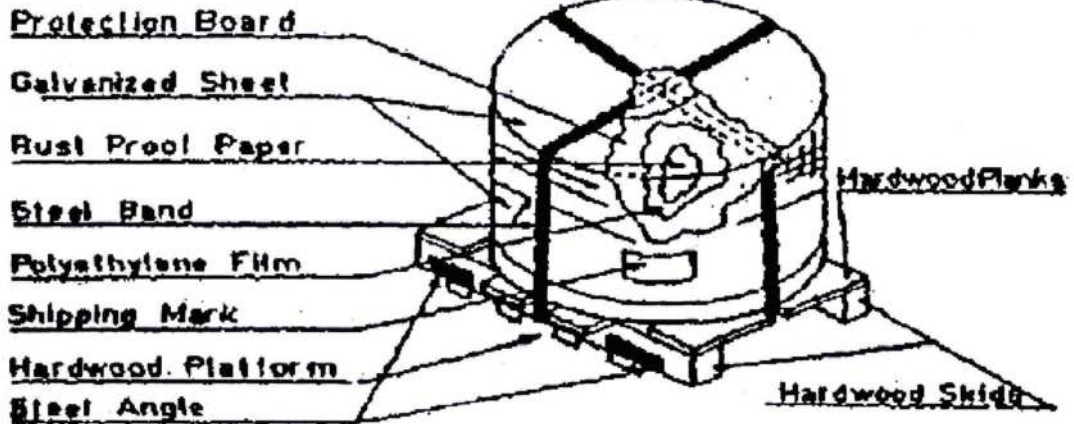



TME 2011

**PRODUCT STANDARD
TME DIVISION, BHOPAL**

TM 10472

Rev 04

PAGE 10 OF 10

11.3 Marking:

A metal label/tag shall be securely attached with each bundle outside its wrapping and shall be legibly marked with the following information.

TM10472 Rev No, BHEL Order No, Supplier's Name/Grade/Identification No., Size & Weight, Melt No., Packet/Bundle No.

12.0 REFERRED STANDARDS (Latest Publications Including Amendments):

- | | | | |
|-----------------|--------------|--------------|------------|
| 1) AA 0851711 | 2) AA 27541 | 3) IS: 648 | 4) IS:649 |
| 5) DIN EN 10106 | 5) DIN 50462 | 7) AISI, C-6 | 8) AA10917 |
| 9) 4TMS.096.053 | | | |

**GENERAL INFORMATION FOR CALCUALTION
(NOT MANDATORY/TYPICAL VALUES)**

Density	:	7.7 kg/dm ³
Magnetic induction (B) at 30,000 A/m (Peak) A/C	:	Magnetic field Strength (H) (Peak) 1.97 Tesla, min - 0.5mm, thick
Total specific loss at 1.0 Tesla	:	2.30 watts/kg, max for 0.50mm
<u>Mechanical Properties (Typical):</u>		
Tensile strength	:	430 N/mm ²
Yield strength	:	290 N/mm ²
Elongation on 5.65 √So G.L .	:	30%

COPYRIGHT AND CONFIDENTIAL
The information on this document is the property of **BHARAT HEAVY ELECTRICALS LIMITED**
It must not be used directly or indirectly in any way detrimental to the interest of the company



CORPORATE PURCHASING SPECIFICATION

AA10917

Rev No. 07

PAGE 1 of 9

COLD ROLLED NON-GRAIN ORIENTED SHEET STEEL – Gr: 530 (DIFFERENT TYPE OF INSULATION COATING)

1 GENERAL

This specification governs the quality requirements of Un-insulated and insulated (double side), cold rolled, non-grain oriented magnetic steel sheet or coil in finally annealed condition in 0.50 and 0.65 mm thickness.

2 APPLICATION

Laminations of Electrical Machines

3 CONDITION OF DELIVERY

3.1 Cold rolled, finally annealed.

3.2 The material shall be supplied in straight lengths (sheet form) or in coils, to the ordered thickness as specified in BHEL order.

3.3 Magnetic steel sheets or coils shall be supplied with or without insulation coating, as detailed below and as called for on BHEL order.

a) 0.50mm/0.65mm Thick - insulated *

Double side insulated with an average of 5.5 ± 1.5 micron thickness coating on each side. The insulation coating shall comply with clause 3.4 and 8.6 of this specification.

b) 0.50mm/0.65mm Thick – Un-insulated*

Un-insulated, protected on both sides by rust preventive coating of thickness 2 ± 1 microns.

*NOTE

i) The supplier shall furnish the details of such coatings along with the quotation as per Annexure-I of BHEL standard AA0851711 for approval of BHEL prior to the first time supply and / or as when the type of coating is changed subsequently with the prior approval of BHEL.

ii) The surface finish of the material shall be such as to allow subsequent uniform varnishing, if required, without any problem.

3.4 Type of insulation coating

The insulation coating used for the steel sheets referred in clause 3.3 (a) shall be uniformly applied, tightly adherent and shall be as per BHEL specification AA27541 or as per AISI, C-6 of the filler base type on both sides, pigmented varnish coating (in which case it shall be compatible to varnish as per AA27541) and also suitable for fully impregnated electrical machines (VPI) and shall meet the requirements detailed in clause 8.6.

Revisions:

Brought upto date

APPROVED:

INTERPLANT MATERIAL RATIONALISATION
COMMITTEE – MRC(E&IM)

Rev No.07

Amd No.

Reaffirmed

Prepared

Issued

Dt. of 1st Issue

Dt:15-06-2017

Dt:

Year:

HEEP, Haridwar

Corp.R&D

01-06-1993



4 COMPLIANCE WITH NATIONAL STANDARDS

- 4.1 Material shall comply with the requirements of IS 648-2006 Gr: 50C530 for 0.5mm thick and Gr: 65C530 for 0.65mm thick.
- 4.2 Material offered to EN 10106-2015, Gr: M530-50A for 0.50mm thick and M530-65A for 0.65mm thick is also acceptable.

5 DIMENSIONS AND TOLERANCES

5.1 Sizes

Magnetic steel sheet shall be supplied to the dimensions and coating specified on BHEL order.

5.2 Tolerances

5.2.1 Thickness

The permissible deviation in nominal thickness shall be $\pm 8\%$. The variation in thickness in a direction parallel to the direction of rolling shall not exceed $\pm 8\%$ of the nominal thickness.

The variation in thickness in a direction perpendicular to the direction of rolling shall be $\pm 0.020\text{mm}$ for a nominal thickness of 0.50mm and $\pm 0.030\text{mm}$ for 0.65mm thick. The measuring points should be at least 40mm away from the edges of the sheets.

5.2.2 Width

The tolerance for width of material supplied with trimmed edges shall be as follows:

Width (mm)		Tolerance (mm)	
Over	Upto & incld.	Plus	Minus
-	150	0.3	0
150	500	0.5	0
500	1250	1.5	0

5.2.3 Length

When supplied in sheet form the tolerance on length shall be +1%, but shall not exceed $\begin{matrix} +10 \\ -0 \end{matrix}$ mm.

5.2.4 Straightness/Edge camber

The straightness tolerances for the longitudinal edge (edge camber) over a gauge length of 2000mm shall not exceed 4mm for width up to and including 150mm and 2mm for widths exceeding 150mm.

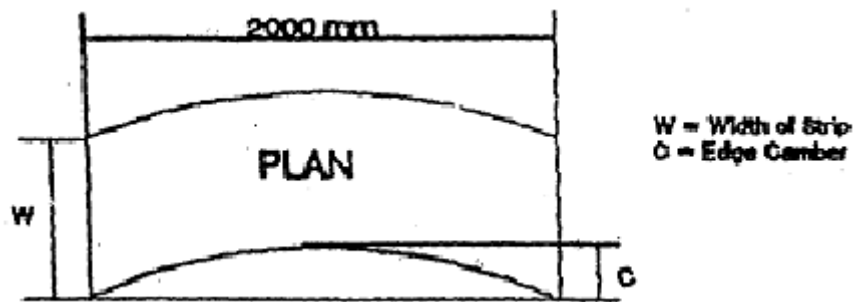

5.2.5 Edge Burr

The height of edge burr shall not exceed 50 microns.

5.2.6 Bowing – Coils

The material when unwound from a coil shall be placed flat on a level smooth surface (surface plate) such that it has a radius not less than 3000mm. The specimen should be stood upright and free from constraint with one longitudinal edge on the surface of the plate. A straight edge with a length of 500mm, when placed against the specimen and when measuring the greatest distance 'h' between the straight edge and the product should not be more than 10 mm as detailed below:

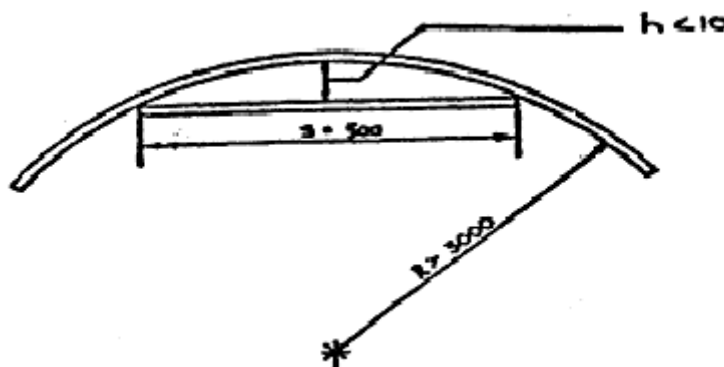

5.2.7 Waviness/Flatness

The Waviness/Flatness shall not exceed 1.5% (i.e the ratio of the wave height to wave length).

6 FINISH

The material shall have a smooth surface and shall be free from loose scale, buckle or dents, waviness and internal stresses.

7 TEST SAMPLES

The test samples of the same heat/melt & thickness shall be selected from the consignment as follows

Upto 30 tonnes	1 sample
Above 30 to 60 tonnes	2 samples
Above 60 tonnes	3 samples

The test samples shall be sufficient in size to provide the necessary test pieces.



8 PROPERTIES (AS RECEIVED)

8.1 Bend Test

A test piece of 30mm width X 60mm long taken in rolling direction in the ordered thickness shall withstand the minimum number of bends specified below, without fracture, through 90° from initial position; then bend it through 180° in the reverse direction. Again bend the specimen through 180° in the first direction and continually through 180° reversals, over a 5mm radius jaws when tested to IS 649/ EN 10106.

0.50mm thick: 10 bends

0.65mm thick: 5 bends

8.2 Stacking Factor

The surface quality of the sheets when measured in terms of stacking factor as per IS 649 (on a minimum of 16 samples under a pressure of 35 N/cm²) shall be as follows:

0.50mm and 0.65mm thick double side coating (insulated) : 95.5%, minimum

0.50mm and 0.65mm thick un-insulated : 97% minimum

8.3 Total Specific Loss

The total specific loss on aged specimens (a specimen which has been heated for 24 hrs. at 225±3°C) for 0.50mm thick and on unaged specimen for 0.65mm thick sheet shall be as follows, when tested as per IS 649 at a frequency of 50 Hz for the specified flux density.

5.30 watts/kg, Maximum – At 1.5 Tesla

8.4 A.C Magnetization

When tested to IS 649, the AC magnetic field (H) in ampere/metre (Peak), shall show the following minimum corresponding values of magnetic induction (B) in Tesla (Peak) for 0.50mm and 0.65mm thick material.

AC Magnetic field Strength 'H' A/m (Peak)	Magnetic Induction Min. (Peak)	(B) Tesla
Thickness	0.50 mm	0.65 mm
2500	1.50	1.52
5000	1.64	1.62
10000	1.74	1.72

**8.5 Anisotropy of Losses**

When tested to IS 649/EN 10106 as detailed below, the Anisotropy losses shall not exceed:

±10% for 0.50mm thick sheet

±12% for 0.65mm thick sheet

To determine the loss ANISOTROPY the specific total loss should be measured separately on specimens taken parallel and perpendicular to the rolling direction. The loss Anisotropy, in percent, is found from the following expression

$$\frac{P_a - P_l}{P_a + P_l} \times 100 \text{ where}$$

P_a denotes specific total losses perpendicular to the rolling direction.

P_l denotes the specific total losses parallel to the rolling direction.

8.6 Testing of insulation coating

The insulation coating when tested in accordance with BHEL standard AA0851711: Test Methods for Insulation Coating on Magnetic Steel Sheets, shall show the following properties:

8.6.1 Selection of Test Samples for Insulation Coating

The outermost and innermost turn of coil or the topmost and bottommost of a stack of sheets, shall be considered as wrapping and not representing the properties of the remaining material and hence shall not be considered for test specimen.

In case of coils, the test specimens shall be preferably taken from the first external turn excluding the wrapping turn and in case of sheet, it shall be from the upper part of the stack. In special case, it can be taken from any other part also.

The test specimen shall extend over the entire sheet width and can be about 350 ± 2 mm long. In case of sheet width, below 400mm, the specimen shall be 500 ± 2 mm long.

The surface of the strip shall be free from contaminations & damages and shall be cut without deformation and as far as possible, without burrs. Any cleaning done shall not damage the insulation coating.

8.6.2 Coating Layer Thickness

Both sides of the sheet shall be coated and shall have an average thickness of 5.5 ± 1.5 microns on each side. At least 15 readings shall be taken on each side at equal intervals. None of the readings should be below 2.0 microns.

The thickness of any pre-coating shall not be accounted for.

8.6.3 Surface insulation Resistivity

The minimum average of 10 non-overlapping resistance measurements (5 on each side) shall be 30 ohm-cm^2 with a minimum allowable individual value of 10 ohm-cm^2 .



8.6.4 Type Tests

8.6.4.1 Adherence Test

The surface coating shall be sufficiently adherent so that it does not get detached during insulation and shearing. In the reverse bending test with a bending radius of 5mm, the surface coating shall not be detached after bending through 90°.

8.6.4.2 Thermal Effect on Coating

The limiting temperature of the insulation shall be 155±3°C (Class B).

8.6.4.3 Resistance to Solvents, Oils & Ammonia

The insulation film shall be resistant to conventional organic solvents like trichloroethylene, methylated spirit, acetone, benzene, and oil. In special cases and when specified on BHEL order, the insulating film shall be resistant to ammonia also.

* Note

'Type tests' shall be carried out when, 'Type Approval' to a supplier is given and repeated once in five years for the approved supplier.

9 TEST CERTIFICATES

Three copies of test certificates shall be supplied, unless otherwise specified on order.

In addition, the supplier shall ensure to enclose one copy of the test certificate along with their despatch documents to facilitate quick clearance of the material.

The test certificate shall bear the following information

AA10917-Rev 07 / IS 648; Gr: 50C530/Gr: 65C530/EN 10106; Gr: M530-50A/Gr: M530-65A/
ASTM A 677

BHEL Order No.

Supplier's Name/Grade/Identification No.

Size & Weight

Melt No., Packet/Bundle No.

Test results of

- a) Dimensions & Tolerances
- b) Properties as per the concerned National standards & insulation coating, as above.

10 PACKING AND MARKING

10.1 Material Supplied in Straight Length

Magnetic steel sheets shall be supplied in bundles. The packing shall be seaworthy and shall protect the material from damage during transit. A typical packing which would be suitable is shown below.

Each sheet shall be marked with supplier's grade/references.

These markings shall be along the rolling direction.

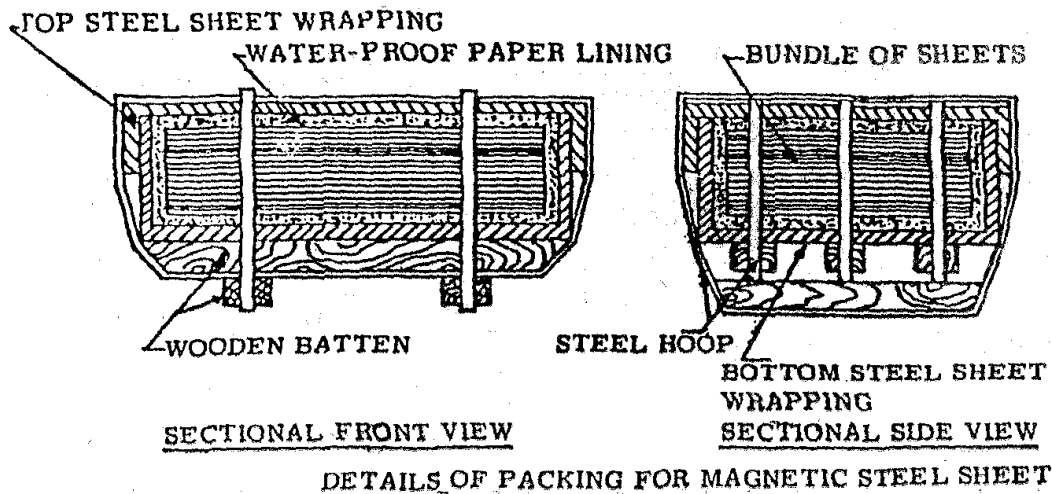

Note:

- a) Water proof paper lining shall be preferably Volatile Corrosion Inhibitor (V.C.I) Coated Paper with an additional polythene (100 micron) enveloped.
- b) Approximate weight of each bundle shall be 2 to 3 metric tonnes. Bundle weighing 2 Metric tonnes is however preferred.
- c) The packing should ensure that there is no seepage of moisture and the sheets reach BHEL on completely rust free condition. It shall be strong enough to withstand handling at the docks, at sea on the road.

10.2 Material Supplied in Continuous Coil

The nominal weight of each coil shall be 1800-2000kg.

The nominal internal diameter of coil shall be 508mm.

Packing shall be sea-worthy and shall protect the coils from damage and rusting during transit. The supplier's grade /reference shall be marked at every one metre intervals throughout the coil length.

Coils shall be vertically packed according to the instructions and drawing given below:

- a) An annular protection board shall be placed at either end of coil.
- b) The coil shall then be wrapped with waterproof anti-rust proof by lapping axially all around the circumference.
- c) The coil shall then be covered by polyethylene sheet or anti-rust waterproof paper and the ends sealed properly.
- d) A galvanized sheet shall be wrapped on the outside of the coil and the top and bottom of the coils. Care shall be taken to ensure that the ends of the top and bottom of the coils extend sufficiently over the inside diameter of the coil.
- e) A galvanized sheet shall be wrapped on the inside of the coil. Care shall be taken that it overlaps sufficiently over the ends of the sheet mentioned in (d) above.
- f) Steel ring made from thick angle sheets shall be placed on the rim of the inner diameter at both ends of the coil. The rings shall be held at either ends at four points by steel bands.
- g) The coil should then be mounted on wooden skids held together by steel bands. Wooden skids must have cutouts to house the steel bands for tight fit and to avoid slippage.
- h) The packing shall ensure that there is no seepage of moisture and the coils reach BHEL in completely rust free condition. It shall be strong enough to withstand handling.

- i) Coils shall be sufficiently tight-wound to prevent collapse to an extent that would preclude their being mounted on a mandrel appropriate to the ordered internal diameter.
- j) Each package should indicate the Sling Position, for lifting without damage. It is preferable to fix a suitable size of, 'Sheet Steel Angle', at the position where the Sling Rope is to be fitted to avoid slippage/damage/breakage of the wooden skid at four places.

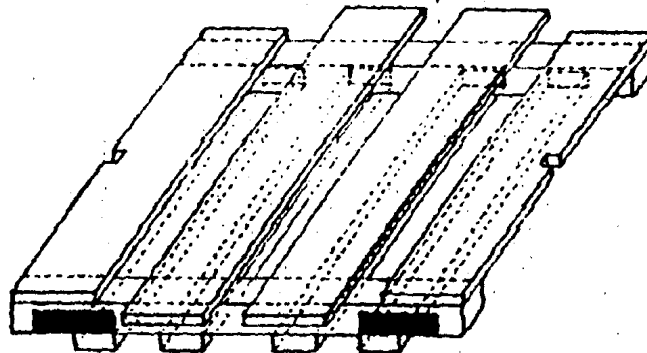
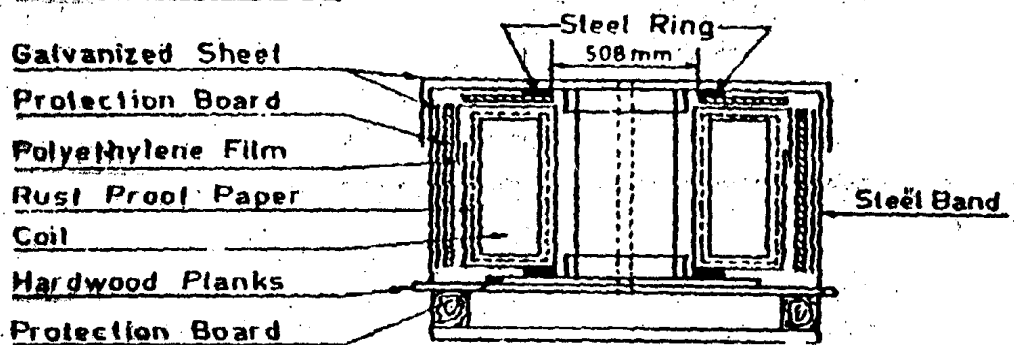
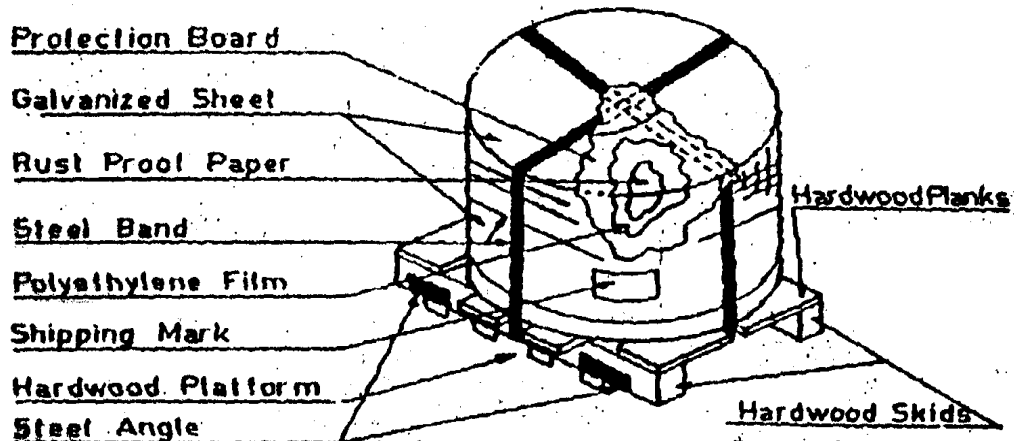

10.3 Marking

A metal label/tag shall be securely attached with each bundle outside its wrapping and shall be legibly marked with the following information.

AA10917

BHEL Order No.

Supplier's Name/Grade/Identification No.

Size & Weight

Melt No., Packet/Bundle No.



11 REFERRED STANDARDS (Latest Publications Including Amendments)

- 1) AA0851711
- 2) AA27541
- 3) IS 649
- 4) AISI C-6
- 5) ASTM A 677

**GENERAL INFORMATION FOR CALCUALTION
(NOT MANDATORY/TYPICAL VALUES)**

Density	: 7.7 kg/cm ³
Total specific loss at 1.0 Tesla	: 1.50 watts/kg for 0.50mm and 0.65mm thick
Magnetic induction (B) at 30,000 A/m	: 1.97 Tesla, min – 0.5mm, thick
Magnetic field Strength (H) (Peak)	: 1.97 Tesla, min – 0.65mm, thick
Total specific loss at 1.0 Tesla	: 2.30 watts/kg, max for 0.50mm & 0.65mm thick

Mechanical Properties:

Tensile strength	: 430 N/mm ²
Yield strength	: 290 N/mm ²
Elongation on 5.65 √S ₀ GL	: 30%



CORPORATE STANDARD

AA 085 17 11

REV.No. 00

PAGE 1 OF 5

TEST METHODS FOR INSULATION COATING ON MAGNETIC STEEL SHEETS

1. GENERAL:

This standard stipulates the test methods for insulation (varnish) coating on magnetic steel sheets. These test methods are applicable for the finished varnish coating applied by the manufacturer before processing the magnetic steel sheets.

The test results shall be furnished in the test certificate formate as per DIN 50049, given in Annexure I.

2. VARNISH COATING:

The type and thickness of insulation coating shall conform to the respective purchase specification of magnetic steel sheets.

3. PREPARATION OF TEST SPECIMEN:

3.1 Number Of Test Specimens:

One test specimen of the same quality and the same nominal thickness per test unit is required. DIN 46400 - Part 1 - Section 7.2 & 7.3 is applicable for classification of test units and number of test specimens.

3.2 Sampling And Preparation Of Specimens:

3.2.1 The outermost and innermost turn of a coil or the top most and bottom most of a stack of sheets shall be considered as wrapping and are not representative of the properties of the remaining material and hence, shall not be considered for test specimen.

3.2.2 In case of coils, the test specimens shall preferably be taken from the first external turn excluding the wrapping turn and in the case of sheet, it shall be from the upper part of the stack. In special case, it can be taken from any other part also.

3.2.3 The test specimen shall extend over the entire sheet width and can be about 350 ± 2 mm long. In case of sheet width below 400 mm, the specimen shall be 500 ± 2 mm long.

3.2.4 The surface of the strip shall be free from contaminations and damages and shall be cut without deformation and as far as possible, without burrs. Any cleaning done shall not damage the insulating coating.

Revision: Refer cl.27.8.3 of
MOM of MRC (E)

Approved:
INTERPLANT STANDARDIZATION
COMMITTEE-WG (MRC(E))

Rev.No.	Amd.No.	Reaffirmed	Prepared	Issued	Dt. of 1st issue
			BHOPAL	CORP. R&D	JAN 94
Dt.	Dt.	Year:			

COPYRIGHT AND CONFIDENTIAL
The information on this document is the property of BHARAT HEAVY ELECTRICALS LIMITED.
It must not be used directly or indirectly in any way detrimental to the interest of the company.

**4. TEST METHODS:****4.1 CURING OF THE VARNISH:**

The test to check whether the varnish is completely cured, shall be done by rubbing the insulation with a pad dipped in methylated spirit with force by hand.

The varnish shall not dissolve by this rubbing.

4.2 Varnish Layer Thickness:

4.2.1 The test method shall be as per DIN 50981 and DIN 50982 - Part 1 and Part 3 with the following :

4.2.2 Methods Of Measurement:

The varnish layer thickness of the magnetic steel sheet shall be determined by the principle of magnetic induction. Conventional measuring instruments shall be used. The instruments shall be calibrated using comparison specimens (2 - point adjustment), before measuring.

4.2.3 Calibration Of The Instrument:

The base material of the sheet to be tested shall be used as the comparison specimen, after the removal of its varnish layer by dissolution in a suitable solvent (e.g. by potassium Hydroxide - 21 weight % KOH) without any change in the surface of the base material. An unvarnished test specimen of the magnetic steel sheet can also be used for this purpose, if available. A non-ferro-magnetic foil of known thickness, approximately same as that to be measured is used as the standard for layer thickness.

4.2.4 Test Procedure:

The varnish thickness is measured at least at 10 points of the test specimen, distribute evenly on the sheet width. The arithmetic mean value of all measurements and double the standard deviation "2S" are given as the layer thickness of varnish coating.

Each side shall be measured separately at the corresponding positions and each test specimen has to fulfill the thickness requirements.

The thickness of any pre-coating shall not be accounted for.

4.3 Inter-Laminar Resistance:

The inter-laminar resistance shall be measured as per ASTM A-717 / IEC 404 (Franklin Test Method).



4.4 Surface Quality:

The surface quality of the magnetic sheets, when measured in terms of Stacking Factor as per IS - 649 / BS 601 - part 5 - Clause 3 (on a minimum of 16 samples under a pressure of $35 \pm 1\% \text{ N/cm}^2$) shall comply with the values specified in the material purchase specification.

The stacking factor shall be calculated from the following relationship :

$$\text{Stacking Factor} = \frac{m}{p \times h \times l \times w} \times 10^{11} \%$$

- where
- m = Total mass of test specimen (kg)
 - p = Density of material (kg/m^3)
 - h = Height of stack (mm)
 - l = Mean length of test specimen (mm)
 - w = Mean width of test specimen (mm)

4.5 Adherence:

The insulation coating shall not peel off when cutting the sheet with a sharp cutting tool (except from the edges). It shall withstand the reverse bending test, specified in the material purchase specification, without damage to the insulation.

5. TYPE TESTS:

The following type tests are to be carried out for varnish type once only. Unless otherwise stated, the specimens are coated with a standard layer thickness of 7 Microns on each side ± 1.5 Microns. However total deviation on both sides of the varnish coating shall not be more than 2.6 mm.

5.1 Thermal Effect On Coating:

Three specimens of varnished strip shall be clamped together under a pressure of $1 \pm 1\% \text{ N/mm}^2$ and heated in a laboratory oven at a temperature of $130 \pm 3^\circ\text{C}$ for a period of one week. After cooling to room temperature, the interlaminar resistance value of the middle specimen shall not be less than the minimum values specified in the material purchase specification.

5.2 Resistance To Oil, Solvent And Ammonia:

5.2.1 Resistance To Solvent:

When tested as per DIN 53168, a cotton plug soaked with the test liquid is placed on the conventionally applied and cured varnished layer and covered with a glass shell and left for one hour.

The varnished layer is compared with an untested specimen after 5 minutes and again after one hour after the test. No visible changes shall appear on the varnished layer.

**5.2.2 Resistance To Oil:**

When tested as per DIN 46456 - Part 1 - Clause 6.3.10, a test specimen of the varnished sheet shall be stored in Transformer Oil (to IS 335) at a temperature of $105 \pm 3^\circ\text{C}$. There should not be any change in the colour of the oil (as compared to its original colour) and varnished layer of the specimen.

5.2.3 Resistance To Ammonia:

This test shall be carried out when specifically mentioned in the order or material purchase specification.

Test specimens shall be of 100 mm x 100 mm size cut from the varnished strip. The edges of the specimen are sealed with paraffin and are kept horizontally (with about 1 cm distance) in a closed vessel at a room temperature of $25 \pm 5^\circ\text{C}$. The bottom of the vessel is filled with 25% aqueous Ammonia solution so that the specimens are exposed to a water vapour ammonia atmosphere.

After storage for four weeks, the varnish coating shall not peel off when scratched by a finger nail.

6. Retests:

As per DIN 46400 - Part 1 - Section 7.6.

7. REFERRED STANDARDS:

The following is the list of the latest standards, as published by the respective issuing bodies, referred to in this specification.

1. IS:649
2. IS:335
3. B.S.601 Part 5. Cl.3.
4. ASTM A-717
5. DIN 46400 -Part 1, Sec 7.2. and Sec 7.6
6. DIN 46456 Part 1.cl 6.3.10
7. DIN 50981
8. DIN 50892-Part 1 and 3
9. DIN 53168



ANNEXURE 1

TEST CERTIFICATE FORMAT (Clause 1)

- 1. Name of Varnish Manufacturer :
- 2. Type of Varnish :

3. PROPERTIES OF THE VARNISH

- 3.1 Type of resin :
- 3.2 Type of filler :
- 3.3 Type of Solvent : Wt. %
- 3.4 Water content in case of water thinnable varnish : Wt. %
- 3.5 Solid content : Wt. % Vol. %
- 3.6 Resin content : Wt.% w.r.t. solids
- 3.7 Filler content : Wt.% w.r.t. solids
- 3.8 Density of varnish : g/ml
- 3.9 Viscosity as per DIN 53211 (4mm, 23°C) : s
- 3.10 Flame point as per DIN 53213 : °C

4. PROPERTIES OF THE CURED VARNISH FILM AFTER PROCESSING, AS PER SPECIFICATION

- 4.1 Surface weight of a 7 μ thick varnish layer (Dry weight) : g/m²
- 4.2 Interlaminar resistance to ASTM A 717/IEC 404 (Franklin Method) : ohm-cm²
- 4.3 Surface quality : %
- 4.4 Thermal effect on coating : °C
- 4.5 Influence on the punching quality of the sheet :
- 4.6 Resistance to oil, organic solvents, water and ammonia. :

5. DATA OF THE VARNISH PROCESSOR:

- 5.1 Name of the varnish processor :
- 5.2 Mode of application :
- 5.3 Drying temperature : °C

5.4 The insulating varnish _____ supplied by _____ is used for our magnetic steel sheet insulation. The varnish is used without any change and as specified by the manufacturer

Date and Signature of the supplier

Note:

Any change in the composition of the varnish or individual substances shall be communicated to BHEL without delay.

**MAGNETIC STEEL SHEET VARNISH****1.0 GENERAL:**

This specification covers the technical requirements of pigmented, water-thinnable and hot curing synthetic resin varnish.

2.0 APPLICATION:

The varnish is used for insulation of cold and hot rolled magnetic steel sheets. The cured varnish is suitable for temperature endurance stability at 180⁰ C and for short periods at 220⁰ C

3.0 COMPLIANCE WITH NATIONAL STANDARDS:

There is no Indian standard covering this material. The standard is based on BHEL experience.

4.0 QUALITY CONTROL TESTS :**4.1 Physical Conditions :**

The varnish shall be homogenous after stirring and freely soluble in water. The varnish shall be free from gelled particles and foreign impurities.

4.2 Density :

1.70 to 1.90 Kg / dm³

4.3 Viscosity :

130 ± 20 seconds at 20 ± 2°C by DIN cup of 4 mm orifice to DIN 53211.

Alternatively

180 ± 30 seconds at 27 ± 2°C by IS flow cup to IS 3944.

Revisions :

32nd MOM of MRC-E

APPROVED :

INTERPLANT MATERIAL RATIONALISATION
COMMITTEE-MRC (E)

Rev. No. 01

Amd.No.

Reaffirmed

Prepared

Issued
Corp. R&D

Dt. of 1 st Issue

Dt:01.11.2002

Dt :

Year :

HARDWAR

APRIL 2002

4.4 Composition of the varnish (in weight %) :

Solid content : 75 ± 5

4.5 pH value : 8.5 ± 1

5.0 INFORMATION FOR REFERENCE :

5.1 Materials :

5.1.1 Type of binder : Phenolic resin, Melamine resin

5.1.2 Organic solvents : Butylglycol, Butyldiglycol, Butanol, dimethylethanolamine

5.1.3 Fillers : Barium sulphate, Zinc sulphide

5.1.4 Solid content by volume : $51 \pm 5\%$ (The volatile portion consists of organic solvents and water in the weight ratio of 7 ± 1 to 20 ± 3).

5.1.5 Composition of solid content (in weight %) :

Total binder content : $29 \begin{matrix} +5 \\ -8 \end{matrix}$ (This includes a maximum of 12% emulsifier part)

Filler content : $71 \begin{matrix} +8 \\ -5 \end{matrix}$

5.1.6 Flash point : Not less than 55°C

5.2 Properties of cured varnish :

5.2.1 Colour : Grey

5.2.2 Lead Pencil Hardness : 7H, min

5.2.3 Interlaminar insulation resistance :

90% of results : Minimum 1 Megaohm-cm² / sheet

10% of results : Minimum 1 Kilo-ohm-cm² / sheet



- 5.2.4 Cross cut test : Gt OB as per DIN 53151
- 5.2.5 Method of usage : The varnish shall be satisfactorily stirrable and processable by means of rubber rollers. (Rubber of shore hardness 40°–60°). The coating, after curing shall have minimum roughness.
- 5.2.6 Test for curing of the varnish on the stamping : A soft cloth moistened with spirit (denatured Ethyl alcohol) is rubbed to and fro with hand pressure 10 times on the varnished surface of the sheet and observed. No varnish material removed from the sheet shall be seen on the moistened cloth. Also, there shall be no softening or dissolving of the insulation layer.

6.0 SHELF LIFE :

When stored in the original sealed container at normal temperature (max. 30°C), the varnish shall have a shelf life of minimum 12 months after delivery and shall satisfy all the requirements of this specification.

7.0 SAMPLING :

A sample shall be taken for testing from each supply after thorough stirring. If the results of these tests do not conform to this specification, two more samples from different containers are taken for repeat testing of those parameters, which were found deviating. If the results of the repeat tests also do not conform to this specification, then the entire supply is considered as not conforming to this specification.

8.0 TEST METHODS :

8.1 Tests for Varnish in as-received condition :

- 8.1.1 Test for Density : This shall be determined by accurately weighing exact volume (minimum 25 ml) of the varnish at the specified temperature and calculating the ratio of weigh to volume.
- 8.1.2 Test for viscosity : This shall be determined by finding the time required for the varnish to flow while using either the DIN or IS flow cup, as the case may be, at the specified temperature.



8.1.3 Test for Solid content : This shall be determined by finding the weight loss in a sample of not less than 0.1 g of the varnish when subjected to a temperature of $80 \pm 5^{\circ}\text{C}$ for 16 hours.

Alternatively, solid content can be determined on 1-2 g sample by finding weight loss at 120°C for 4 hours.

8.1.4 Test for pH value : This shall be determined by using a suitable electro-chemical pH meter.

9.0 TEST CERTIFICATE AND COMPLIANCE CERTIFICATE :

Unless otherwise specified, three copies of test certificates incorporating the properties as per clause 4 and compliance certificate with respect to other clauses shall be supplied with each consignment, indicating the following information :

- AA 275 41 (Rev 01): Magnetic Steel Sheet Varnish
- BHEL Order No.
- Batch / Lot No.
- Date of manufacture
- Size and No. of drums

10.0 PACKING & MARKING :

The varnish shall be suitably packed in 250 Kg drums or as stated in BHEL order to provide adequate protections to prevent any damage during transit and storage. The drum shall have a fully openable and sealable cover.

Each drum shall bear the following information :

- * Magnetic Steel Sheet Varnish
- * Specification No.,
- Batch / Lot No.
- Date of manufacture
- Date of expiry / Shelf life
- Net weight
- Supplier's name / grade



11.0 ACCEPTANCE CRITERIA :

The material supplies shall be accepted on the basis of the following :

- i) Compliance certificate to AA27541, Rev 01 furnished by the supplier.
- ii) Test certificate furnished by the supplier and / or testing carried out at BHEL end.

12.0 ENVIRONMENTAL REQUIREMENTS :

The supplier shall furnish Material Safety Data Sheet (MSDS) covering all information relating to human safety and environmental impacts of the hazardous materials particularly during their transportation, storage, handling and disposal alongwith each supply.

Each container shall be marked with corresponding symbol and minimum worded cautionary notice for flammable / corrosive / toxic / harmful / irritant and oxidizing etc. as applicable.

13.0 REJECTION :

BHEL reserves the right to reject the entire lot of the material, if found not to comply with these requirements. Parts of the lot which are found to be defective or not complying with these requirements can also be rejected at a later stage.

14.0 REFERRED STANDARDS (Latest Publications Including Amendments) :

- 1) DIN 53211
- 2) DIN53151
- 3) IS : 3944