



CORPORATE PURCHASING SPECIFICATION

AA53624

Rev No.01

PAGE 1 of 4

STOPPER HEAD (HIGH ALUMINA GRAPHITE)

1.0 GENERAL:

This specification governs the quality requirements of High Alumina Graphite Stopper used for teeming steel from ladle.

2.0 APPLICATION:

The stopper head will be used for making stopper rods for closing and opening of refractory nozzles there by controlling flow of liquid steel during teeming.

3.0 COMPLIANCE WITH NATIONAL STANDARDS:

The material shall comply with the requirements of following national standard and also meet the requirements of this specification.

IS: 1528-1997: Methods of sampling and physical tests for refractory materials

4.0 SIZE:

The size of the stopper head shall be as per sketch given on page 4 of 4.

5.0 PROPERTIES:

When tested in accordance with the relevant clauses of IS: 1527 and IS: 1528 mentioned against each, the test sample shall show the following values.

6.0 Chemical Composition:

The material when analysed in accordance with IS: 1527 shall conform to the following composition:

Al₂O₃ : 50 - 55%

Carbon : 8 - 10%

Bulk Density : 2.25 g/cc

Apparent Porosity (Volume) : 20%, maximum

Pyrometric Cone Equivalent (PCE) : 35 orton, minimum

COPYRIGHT AND CONFIDENTIAL
The Information on this document is the property of BHARAT HEAVY ELECTRICALS LIMITED.
It must not be used directly or indirectly in any way detrimental to the Interest of the company.

Revisions:
Clause 25.03 of MOM of MRC-FN

APPROVED:
INTERPLANT MATERIAL RATIONALISATION
COMMITTEE – MRC(FN)

Rev No.01	Amd No.	Reaffirmed	Prepared	Issued	Dt. of 1 st Issue
Dt:19-03-2014	Dt:	Year:	CFFP, Haridwar	Corp.R&D	01-01-2004

CORPORATE PURCHASING SPECIFICATION



7.0 INSPECTION AT SUPPLIER'S WORKS:

- 7.1 BHEL reserves the right to witness the testing of the material at supplier works and therefore the supplier shall notify the readiness of the material in advance.
- 7.2 BHEL may also opt for third party inspection. If so, BHEL may either specify a third party or else give a list of third party inspection agencies, out of which supplier may select one of his choice.
- 7.3 The supplier shall offer BHEL's representative all reasonable facilities, without charge to satisfy the latter that the material is being furnished in accordance with this specification. The supplier shall prepare and provide necessary test specimens for testing to be carried out at his premises. If facilities are not available at his works, the supplier shall make necessary arrangements for carrying out the prescribed tests elsewhere.
- 7.4 BHEL may, at its discretion, test the material after receipt and acceptance of the material will be based on the BHEL's test results.
- 7.5 Supplier shall ensure that the material is free from extraneous material. The material shall be rejected if it is not free from extraneous material.
- 7.6 For result of analysis and properties of material the decision of BHEL shall be final and binding on the supplier.
- 7.7 If the material received is not found suitable according to the requirements, it shall be replaced free of cost by the supplier.
- 7.8 For any deviation, demanded by the supplier from the specification, prior approval of BHEL must be obtained.

8.0 TEST CERTIFICATES:

Unless and otherwise stated, one original and three copies of certificates from the original manufacturer shall be supplied along with each consignment.

In addition the supplier shall ensure to enclose one copy of test certificate along with the despatch documents to facilitate quick clearance of the material.

Manufacturer supplying material directly to BHEL should include BHEL PO No. in the Test Certificate. Any other supplier should provide a covering letter along with original manufacturer Test Certificate as above mentioning BHEL PO No.

The test certificates shall bear the followings information:

AA53624, Rev.No.01 - STOPPER HEAD (HIGH ALUMINA GRAPHITE)

BHEL order No.

Manufacturers/ Suppliers Name:

Trade name/ mark, if any:

Batch/ Lot No.

Quantity supplied:

Test results as per clause 4.0

Any other specific information, supplier to convey.



CORPORATE PURCHASING SPECIFICATION

AA53624

Rev No.01

PAGE 3 of 4

9.0 PACKING AND MARKING:

Each stopper head shall be suitably packed in thick corrugated sheet boxes with wood shaving or thermocole granules to avoid damage during transit.

Each consignment shall be legibly marked with the following information.

AA53624: STOPPER HEAD (HIGH ALUMINA GRAPHITE)

BHEL Order No.

Manufacturer's/ Supplier's Name:

Trade name/ mark, if any:

Batch/ Lot No.

Quantity supplied:

10.0 Referred Standards (Latest publications including amendments):

- 1) IS: 1527

CORPORATEPURCHASING SPECIFICATION

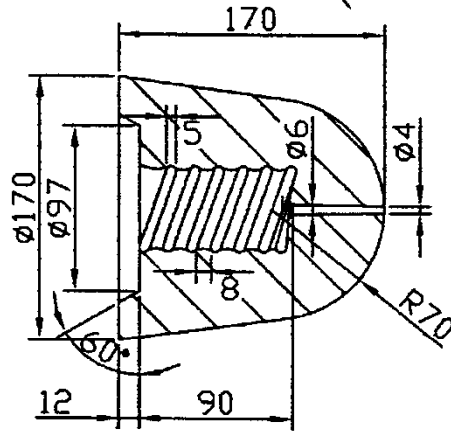
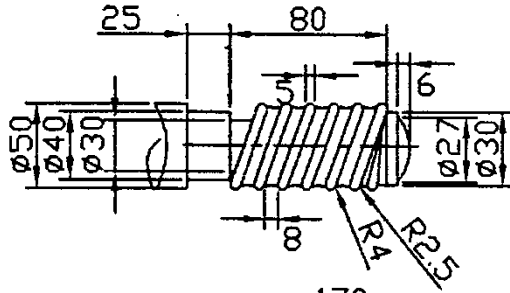

STOPPER ROD
STOPPER HEAD
SIZE S-5

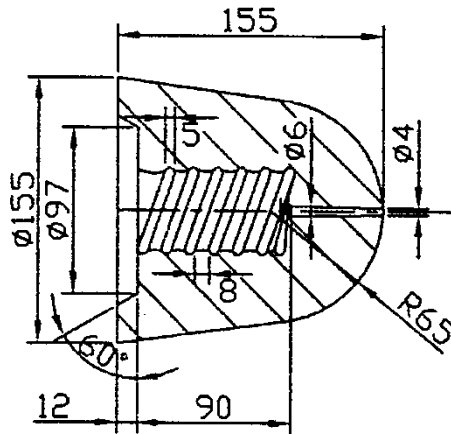

STOPPER HEAD
SIZE S-4/2