



WORKS CONTRACT MANAGEMENT

NOTICE INVITING TENDER	
Tender Notice No	975522072E, DT: 18.03.2023
Nature of work	Fabrication, Inspection, Painting of Packing Steel boxes of various sizes inside BHEL, Ranipet premises with BHEL material.
Type of tender	Open tender (Two part bid)
Period of contract	One Year
Earnest Money Deposit (EMD) Amount	Rs. 51,000/- (Rupees Fifty-One Thousand Only) No EMD exemption for MSE vendors
Tender download start date	20.03.2023
Last date & Time for Receipt of the Tender	31.03.2023 at 12:00 Hrs.
Date of Technical bid Opening	31.03.2023 at 15:00 Hrs. onwards.
Date of Price Bid Opening	Bidders whose technical bids are found acceptable will be intimated separately about the status of their offers and the date of opening of Price Bid/ Reverse Auction.
<i>(Please obtain updated information from the e-Procurement portal about the latest applicable dates & other changes if any in the tender contents)</i>	
Submission of Tender	Online submission through BHEL eProcurement Portal website: https://eprocurebhel.co.in/nicgep/app
Tender Opening	Online through e-Procurement Portal
Note: <ol style="list-style-type: none">The tender documents can be down loaded from BHEL eProcurement Portal website: https://eprocurebhel.co.in/nicgep/app .BHEL, Ranipet reserves the right to accept or reject any or all tenders without assigning any reasons whatsoever.All corrigenda, addenda, amendments, clarifications etc. to tender specification will be hosted in BHEL GePNIC portal only (https://eprocurebhel.co.in/nicgep/app).Bidders shall keep themselves updated with all such developments.BHEL Ranipet reserves the right to reject any tender on the basis of unsatisfactory performance of the bidder in any ongoing job or any similar job in the past.Reverse Auction: BHEL shall be resorting to Reverse Auction (RA) (Guidelines as available on www.bhel.com) for this tender. RA shall be conducted among the techno-commercially qualified bidders. Price bids of all techno-commercially qualified bidders shall be opened and same shall be considered for RA. In case any bidder(s) do(es) not participate in online Reverse Auction, their sealed envelope price bid along with applicable loading, if any, shall be considered for ranking.	

Note: - 1) Tenderer should sign and affix seal in all the pages of this tender document and all supporting documents.

for and on behalf of BHEL,
Deputy Manager /WCM

(signature & seal of bidder)



Bharat Heavy Electricals Limited
(A Government of India Undertaking)
Boiler Auxiliaries Plant
Ranipet-632406

Ref No. 975522072E

INDEX

Chapter	Description	Page No
1	Scope of Work	3-7
2	Pre-Qualifying Requirements (PQR)	8-9
3	Check List	10
4	Instructions to Bidder	11-18
5	Special Terms & Conditions of Contract	19-34
6	General Terms & Conditions of Contract	35-49
7	Declaration	50
8	Bank Details	51
9	EFT Form	52
10	BOQ	53
11	e-procurement Price Bid Format	54
12	Annexure-I	55-62

(signature & seal of bidder)



Scope of Work

1. Brief Scope of Work: -

- a) Manufacture of Steel Boxes inside BHEL, Ranipet factory premises with BHEL material as per the BHEL Drawings Annexure-I page no 55-62, with one coat of Red Oxide/any other similar paint as stated by BHEL.
- b) Where in BHEL Scope is restricted to providing Open Yard space, EB Power Supply and Consumables restricted to Compressed air, Welding Electrodes, Paints and Thinner. Facilities and equipment required for fabrication, cutting, grinding like electric welding m/c, gas welding, Oxygen, LPG, Acetylene and other consumables are in Vendor's scope.
- c) Adherence to Safety practices including protective equipment, by fitters, welders & laborers is in Vendor's scope.
- d) Collection of Raw materials (from Stores inside BHEL factory Premises), handling of job during fabrication, loading / unloading and transportation of finished goods to shipping department (Inside BHEL Factory premises, S3 Yard and S4 Yard), transportation of scrap material and Empty Tins to Disposal Stores yard (inside BHEL factory Premises) are under Vendor's scope.
- e) Ensuring social distancing. usage of protective mask, gloves and hand sanitizer is in Vendor's scope.

2. Scope of Contractor:

- a) The fabrication has to be done in BHEL factory premises as allotted by BHEL.
- b) Engagement of adequate manpower to cater shipping delivery requirement.
- c) Consumables like oxygen and acetylene cylinders as required for welding
- d) Internal and external transportation of raw material, paint and any such material needed for fabrication to the allotted fabrication area
- e) Fabrication of structural steel Components / items including power tool cleaning, grinding, cutting, painting and stenciling etc. as per BHEL drawings and specifications.
- f) The contractors shall bring all other accessories like welding machines (high efficiency and less power consumption) including welding electrodes, gas cutting sets including gas, grinding machine with grinding wheels, drilling machine with drill bits, tools &

(signature & seal of bidder)



Bharat Heavy Electricals Limited
(A Government of India Undertaking)
Boiler Auxiliaries Plant
Ranipet-632406

Ref No. 975522072E

tackles, crane(s), safety equipment, ladders, tools required for spray painting, male & female collectors from power source etc. to carry out the fabrication work

- g) Any consumables which are not mentioned in BHEL scope
- h) Delivery of fabricated boxes to various yards (S3 and S4 yards which are located outside factory premises) based on Shipping department need
- i) Adhering to statutory norms and safety guidelines issued from time to time by BHEL
- j) Coordination for material collection, inspection and billing is under contractor scope
- k) Returning of any excess materials including prime material / big size scrap/cut bits/ scrap/fasteners/empty paint drums etc. to BHEL stores as instructed by BHEL Engineer.
- l) Material accounting and bill coordination with various departments.

3. Scope of BHEL:

- a) Providing open yard space with welding points for ease of fabrication.
- b) All materials required as per BOM of the drawings.
- c) Paint and welding electrodes as per requirement will be provided
- d) Stress relieving of the welded components (if required) is in BHEL scope.
- e) Compressed air for painting of boxes will be made available
- f) Power supply will be provided at free of cost for fabrication needs.

4. Loading & Counter Offering: It is proposed to award the contract to a maximum of **four contractors** by counteroffering finalized L1 rate to other technically qualified bidders in seriatim basis to divide the work load and faster delivery of boxes.

- a) If any other three bidders accept counteroffered L1 rate, load sharing will be 40% for L1 bidder and 30%, 20% & 10% other three bidders respectively in seriatim basis as per ranking.
- b) If only two bidders accept counteroffered L1 rate, load sharing will be 50% for L1 bidder and 30% & 20% to other two bidders respectively in seriatim basis as per ranking
- c) If only one bidder accepts counteroffered L1 rate load sharing will be in the ratio of 60:40 for L1 & other counteroffer accepted bidder respectively.

(signature & seal of bidder)



Bharat Heavy Electricals Limited
(A Government of India Undertaking)
Boiler Auxiliaries Plant
Ranipet-632406

Ref No. 975522072E

- d) If no other bidders accept counteroffered L1 rate, entire 100% load has to be taken by L1 bidder.
- e) If only one bidder qualified, entire 100% load has to be taken by L1 bidder.

5. Bill of Quantity

Packing Boxes-BoQ				
Sl. No.	Description	Unit	Qty	Refer Assembly Drawing no.
1	Type I Box	Nos.	1600	2-79-000-01740 REV07
2	Type I Box-SH	Nos.	600	2-79-000-07777 REV00
3	Type II Box	Nos.	1200	2-79-000-01714 REV06
4	Type II B Box	Nos.	1200	2-79-000-01715 REV04
5	Type III Box	Nos.	500	2-79-000-01713 REV07
6	Type IV Box	Nos.	500	2-79-000-01741 REV06
7	Type V Box	Nos.	300	2-79-000-01742 REV05

- 6. Delivery Schedule:** The details w.r.t delivery will be provided to each awardee along with LOA based on the percentage of awarded work. The total work will be distributed throughout the contract period. The distributed fabrication work will be sequentially awarded through PO with a specific delivery time.

7. Work Related Special Conditions

- a) The works are to be carried out and/or to be completed within the stipulated period and if necessary the contractor shall take necessary steps to augment the work force.
- b) *BHEL will allocate suitable open yard space inside BHEL premises to carry out the scope of work covered in this Tender. Sufficient levelled open area will be provided by BHEL. Further levelling, consolidation if required will have to be carried out by the Contractor.*
- c) For manufacturing of Steel Boxes inside BHEL's Factory Premises with BHEL material as per BHEL drawing, apart from providing of Open Yard-Space, Power supply and Consumables Restricting to Compressed Air, Welding Electrode and Paints are to be supplied by BHEL. Oxygen and Acetylene required for welding, arrangement of internal transport for movement of materials within factory premises and any other consumables required are with Vendor's scope.
- d) The contractor shall be solely responsible for the safe custody of the materials from the time the documents are handed over to him till the materials are delivered at the places

(signature & seal of bidder)



Bharat Heavy Electricals Limited
(A Government of India Undertaking)
Boiler Auxiliaries Plant
Ranipet-632406

Ref No. 975522072E

specified by BHEL and will indemnify the BHEL against loss, damage, breakage, shortage and pilferage of any materials while in their custody. BHEL norms shall be followed for all BHEL free issue items. Transport insurance if any has to be paid by the contractor as may be directed by BHEL.

- e) The period of the contract is One year and this may be reduced, renewed or extended at the discretion of BHEL.
- f) In case of any neglect or refusal on the part of the contractor to provide and non-readiness, insufficient readiness, insufficient labour for the aforesaid work or if in the opinion of Officer-in-charge, the services provided by the contractor are not satisfactory, the Officer-in-charge shall be at liberty to make such arrangement as he may deem fit at the cost and expenses of the contractor. The contractor shall be advised of the amount so incurred and he shall be bound to remit the sum within three days from the date of receipt of such advice. Failure to do so will entitle the Officer-in-charge to deduct the sum from the Security Deposit or from any money due to the contractor. Also BHEL reserves the right to cancel the contract and initiate alternate action at the Cost & Risk of such tenderer.
- g) The contractor shall either supervise the work or provide a supervisor to supervise the work of their staff. The supervisor employed by the contractor shall ensure proper out-turn of work and the discipline by the labour to be put on the job and in general see that the works are carried out in a safe and proper manner. The supervisor shall have technical qualification and experience to carry out the jobs.
- h) The contractor shall withdraw their labour only after obtaining the prior approval of the Officer-in charge and they shall arrange to re-employ the labour within a day from the date of intimation to them.
- i) BHEL is not responsible for the idle labour of the contractor for whatever reasons.
- j) Should any error or ambiguity be discovered in the specification or information, the contractor shall forthwith bring the same to the notice of BHEL before commencement of work. The BHEL's interpretation in such cases shall be final and binding on the contractor.

(signature & seal of bidder)



Bharat Heavy Electricals Limited
(A Government of India Undertaking)
Boiler Auxiliaries Plant
Ranipet-632406

Ref No. 975522072E

- k) In case the labour strength has to be increased to complete the work within the stipulated period, no extra claim for payment under any circumstances will be entertained.
- l) BHEL reserves the right to decide the suitability of the workers and other personnel who may be employed by the contractor. All movements of Men & Material are to be done through BHEL-East Gate/Shipping Gate only
- m) In case of damage or loss to any equipment's or components or any property of BHEL caused due to the negligence and carelessness of the contractor's men, the responsibility shall rest with the contractor. The actual cost of the damage or loss together with the overhead will be recovered from the contractor's bill. The decision of BHEL regarding the cost as well as the extent of cost of damage shall be final and conclusive. Necessary insurance coverage for all the risks to be taken by contractor.
- n) The contractor if required has to work in late hours with sufficient manpower to complete the task within the specified schedule date; BHEL will provide the necessary permission. All the other things are to be taken care by the contractor.
- o) Onsite Inspection: The awarded fabrication work will be done in the factory premises; hence progress will be periodically monitored by concern agencies.
- p) Job Inspection: The job will be inspected by the third party inspector assigned by Quality department of BHEL, Ranipet.

(signature & seal of bidder)



Pre-Qualification Requirements (PQR)

As Essential 'Qualification Requirements' for the submission of tender shall be as follows:

1. Average annual financial turnover:

- a) Average annual financial turnover of any 3 Financial Years out of last 5 financial years (beginning from (01.04.2017-31.03.2022)) should not be less than Rs.7.62 lakhs.
- b) The bidder has to submit financial accounts (audited, if applicable comprising of Audit report, Balance Sheet, Profit & Loss A/c Statement and Notes/Schedules pertaining to Turnover/Sales/Revenue), for 5 years (or from the date of incorporation, whichever is less) as on tender due date to review the above criteria.
- c) In case the incorporation of vendor is less than 3 years, average annual financial turnover shall be calculated based on available information as below:
 1. If the accounts are available for ≤ 1 Financial Year, the Average Annual Turnover shall be calculated based on available information divided by 1 (One)
 2. If the accounts are available for >1 Financial Years but ≤ 2 Financial Years, the Average Annual Turnover shall be calculated based on available information divided by 2 (Two)
 3. If the accounts are available for >2 Financial Years but ≤ 3 Financial Years, the Average Annual Turnover shall be calculated based on available information divided by 3 (Three).
- d) While calculating Annual Turnover / Sales, other operating income and other income shall not be considered.

2. Work Experience

- a) The contractors should have experience of successfully execution of Fabrication of steel packing boxes / steel components/structures" during the last 7 years ending last day of month previous to the one in which applications are invited should be either of the following:

Three similar completed works each costing not less than the amount equal to **Rs.10.17 Lakhs** (excluding GST). (or)

Two similar completed works each costing not less than the amount equal to **Rs.12.71 Lakhs** (excluding GST). (or)

One similar completed work costing not less than the amount equal to **Rs.20.34 Lakhs** (excluding GST).
- b) Documents Required: Bidder has to submit LOA's of the works completed and corresponding work completion certificate.
- c) The work executed in the own name of the bidder only will be considered for similar works executed for meeting the eligibility criteria.

(signature & seal of bidder)



Documents required in support of Pre-Qualifying Requirement

- a) Complete tender document in all respects duly signed & sealed on each and every page by the authorized signatory of the tenderer as a token of acceptance of all the terms and conditions of tender.
- b) Self-attested Copy of the valid PAN card and Certificate of Registration of GST
- c) Self-attested Copy of Balance Sheet and profits & loss Account statements duly certified as per Clause 1 of Pre-Qualification Requirements (PQR)
- d) Self-Attested copies of acknowledgements of IT return of last three financial years i.e. [for Financial Year 2019 - 20, 2020 - 21 & 2021 - 22] (AY 2020-21, 2021-22 & 2022-23).
- e) Self-attested Copy of proof of Work Experience as per Clause 2 of Pre-Qualification Requirements (PQR)

BHEL reserves the right to cross check the documents from the issuing department, and/or call for any additional documents including Bank Statement for verification.

Note:

- i) Those who are unable to comply the above points / unable to provide any of the above documents shall be technically rejected and the price bid of the rejected offers will not be opened.
- ii) The work executed in the own name of the bidder only will be considered for similar works executed for meeting the eligibility criteria.
- iii) Bidder may visit the Plant before submitting their offer to get to know the location for deploying suitable personnel for these works & understanding the scope of work (if required).
- iv) BHEL, Ranipet reserves its right to reject the tender on account of unsatisfactory past performance by the bidder in other projects awarded under different enquiry.
- v) Offers of the Contractors/Suppliers, against who, any unit of BHEL had initiated process for banning or already banned will summarily be rejected.
- vi) Possession of PF registration number is not mandatory. However, the successful tenderer has to register with PF authorities and furnish the registration number before first Running Account Bill.

(signature & seal of bidder)



Bharat Heavy Electricals Limited
(A Government of India Undertaking)
Boiler Auxiliaries Plant
Ranipet-632406

Ref No. 975522072E

CHECK LIST

(to be filled by Bidder)

S No	Description	To be filled by bidder
1	Name of the Tenderer	
2	Address for Communication	
3	Email Cell Phone Fax	
4	Whether the firm is individual firm or Sole proprietorship firm or partnership firm or Hindu undivided Family or association of persons or Private Limited company or Public Limited company or any other please specify	
5	Whether the contractor has registered his workmen under employees State Insurance Act. If so, the Registration No./ Enrolment Number may be furnished. (Photo copy is to be enclosed)	
6	PAN no and documentary proof (Photo copy has to be enclosed)	
7	The GST heads under which the enlisting person registered with GST Authorities and copy of GST registration certificate has to be enclosed.	
8	Whether the contractor has registered his workmen under Employees Provident Fund and Miscellaneous Provisions Act. (Photo copy is to be enclosed)	
9	Applicable GST quoted Note: Please refer clause no.9 (page no. 13) of Special Instructions of this Tender regarding GST.	Central tax@ _____% State tax @ _____% Integrated tax@ _____% Union territory tax@ _____%
10	EMD Details	
11	MSE Details (if applicable)	
12	Start Up details (if applicable)	

(signature & seal of bidder)



Instructions to Bidder

1. Earnest Money Deposit (EMD) amount of **Rs. 51,000/- (Rupees Fifty-One Thousand Only)** must be accompanied with the tender in the form of:
 - a) Demand Draft (DD) drawn from any nationalized bank in favour of “BHEL, Ranipet” payable at Ranipet (or) SBI, Mukundarayapuram (code 7013).
 - b) Fixed Deposit Receipt issued by scheduled banks/ Public Financial Institutions as defined in the company’s act. FDR should be in the name of the contractor, a/c BHEL.

Note: If bidder is paying EMD through Demand Draft or Fixed Deposit Receipt (FDR), original copy to be sent to the following address before tender opening date:

**Deputy Manager/ WCM DEPARTMENT,
ENGG. BUILDING – GROUND FLOOR (WEST SIDE),
BHARAT HEAVY ELECTRICALS LIMITED,
RANIPET, Ranipet DISTRICT,
TAMIL NADU– 632 406.**

Tenders must be addressed to the Deputy Manager/WCM in a sealed cover by super scribing the tender enquiry number on the cover. Also scanned copy of EMD to be submitted along with the technical bid.

- c) Pay online (SBI Collect)
 - i) Visit <https://www.onlinesbi.com/sbicollect/icollecthome.htm>
 - ii) Click “Proceed” button
 - iii) Select “Tamilnadu” in the drop down menu under “State of Corporate/Institution”.
 - iv) Select “PSU-PUBLIC SECTOR UNDERTAKING” in the next drop down menu under “Type of Corporate/Institution”
 - v) Click “Go” button
 - vi) Select “BHEL BAP RANIPET” in the drop down menu under “PSU-PUBLIC SECTOR UNDERTAKING”.
 - vii) Click “Submit” Button
 - viii) Select “EMD” in the drop down menu under “Select Payment Category”
 - ix) Now Fill in the required details and ensure correctness of data filled. Ensure that you are entering correct enquiry/tender number and other details correctly.

(signature & seal of bidder)



Bharat Heavy Electricals Limited
(A Government of India Undertaking)
Boiler Auxiliaries Plant
Ranipet-632406

Ref No. 975522072E

- x) Make payment for EMD as required in tender after entering the details and enclose copy of receipt along with tender documents.
- d) Bidders can pay EMD through online on below account:

NAME OF BANK	State Bank of India
BANK BRANCH ADDRESS	State Bank of India BHEL Project Branch Mukundaraya Puram BHEL Township Ranipet-632406
ACCOUNT NO	10664849171
MICR CODE	632002003
IFSC CODE	SBIN0007013
SWIFT CODE	SBININBB450

- The Earnest Money Deposited by the successful tenderer will be retained towards security deposit for the due fulfilment of the contract.
- In the case of unsuccessful tenderers, the earnest money will be refunded normally within 15 days of acceptance of award of work by the successful tenderer.
- “No interest shall be payable by BHEL on Earnest Money or Security Deposit, if applicable, or any money due to the contractor by BHEL”.
- “BHEL shall have the right to recover any money due from the contractor from any money due to the contractor under this contract or any other contract or from the security deposit”.
- Bidder have to submit their offers through BHEL e-procurement portal only. Bidder has to quote total lump sum value excluding GST & GST % as per BOQ.**
- The Bharat Heavy Electricals Limited, reserves the right to reject any or all the tenders received or accept any tender or part thereof without assigning any reason there for.
- Should a tenderer or a contractor has a relative or in the case of a firm or company of contractors, any of its shareholders or shareholder’s relative, employed in Bharat Heavy Electricals Limited, the authority inviting tenders shall be informed of this fact at the time of submission of the offer, failing which the offer may be disqualified or if such fact subsequently come to light, the contract may be cancelled.
- BHEL employees and their dependents are NOT eligible to submit their offer against this contract. Even if they submit out of ignorance, the offer shall be disqualified.

(signature & seal of bidder)



Bharat Heavy Electricals Limited
(A Government of India Undertaking)
Boiler Auxiliaries Plant
Ranipet-632406

Ref No. 975522072E

10. If the contractor deliberately, gives wrong information in his tender or creates conditions favourable for the acceptance of his tender, Bharat heavy Electricals Limited reserves the right to reject such tender at any stage.
11. Canvassing in any form in connection with the tender is strictly prohibited and the tenders submitted by the contractors who resort to canvassing will be liable for rejection.
12. The tender documents must be signed physically / digitally by Director / Partner of the Firm or by the person holding the Power of Attorney on behalf of the Firm concerned. In the latter case, a copy of Power of Attorney, duly attested by a Notary Public must accompany the tender.
13. The tender schedule, and the tender shall be deemed to form an integral part of the contract to be entered into for this work.
14. Tender can be cancelled at any stage due to unavoidable circumstances.
15. The evaluation currency for this tender shall be INR.
16. Multiple Bids: - The bidder in his own interest shall submit only one bid. If a bidder submits multiple bids, all the bids are liable for rejection. Bids shall be considered "Multiple" in the following circumstances:
 - a) Two bids by the same party
 - b) If one bidder is the affiliate of another bidder.For the purpose of this clause "Affiliate" shall mean with respect to any person, any other person that directly or indirectly, controls, is controlled by, or is under direct or indirect common control with, such person, or is a director/ member/ office/ employee of such person or of any person who would otherwise qualify as an affiliate of such person pursuant to this definition.
"Person" for the purposes of this definition shall mean any natural person, individual, corporation, limited partnership, co-operative, general partnership, joint stock company, joint venture, association, company, trust bank, trust company, land trust, business trust, corporate body or other organization, whether or not a legal entity.
17. Offers of the Contractors/Suppliers, against whom, any unit of BHEL had initiated process for "Suspension of Business Dealings" or already done will summarily be rejected.

(signature & seal of bidder)



Bharat Heavy Electricals Limited
(A Government of India Undertaking)
Boiler Auxiliaries Plant
Ranipet-632406

Ref No. 975522072E

18. If at any stage, the document(s) submitted by contractor is/are found incorrect/ false/ manipulated, the necessary action will be taken by BHEL against contractor as per the "Guidelines for suspension of Business dealings".
19. **Suspension of Business dealings with Suppliers:** Any supplier against whom action has been initiated under "suspension of business dealings with suppliers" are not qualified to participate in this tender. Before submitting offer, prospective bidders are advised to visit our web-site www.bhel.com / supplier registration to familiarize themselves with BHEL's policy and procedures of Suspension of Business Dealings with Suppliers. Submission of offer shall be deemed to be evidence of the Bidder to have read and understood the above said policy.
20. **Treatment of Banned / Under-performing Vendors:** Any supplier who has been put on "Hold" or "Banned" from having business dealings with BHEL, Ranipet or any other unit of BHEL shall not submit their offer against this tender. If any such offers are received they would be summarily rejected and sent back. During the processing of tender, if any unit of BHEL puts a supplier on "Ban" then further processing of the offer will not be taken up and in case an order is placed, BHEL, Ranipet may resort at their discretion to cancel the PO either fully or partially.
21. In quoting the rates, the tenderers are advised to take into account of all the factors including any fluctuations in the market rates etc. No claim shall be entertained on this account after acceptance of the tender or during the currency of the contract.
22. **QUOTING:** The tenderer should quote the total lump sum price for the entire contract scope.
23. The rates quoted in the tender shall remain valid for a period of three months from the date of technical bid opening for acceptance by BHEL. No unsolicited revision in the tender offer shall be entertained after opening of tenders and till expiry of the validity period.
24. Any deviation to this tender terms & conditions and schedules of this tender will lead to total rejection of the offer submitted.
25. The Tenders shall closely pursue all the clauses, specifications indicated in the tender documents before quoting. Should the bidder have any doubt the meanings of any portion of the tender specification or find discrepancies or the tender documents issued are incomplete or shall require clarification on any of the technical aspect, scope of work etc.,

(signature & seal of bidder)



Bharat Heavy Electricals Limited
(A Government of India Undertaking)
Boiler Auxiliaries Plant
Ranipet-632406

Ref No. 975522072E

he shall at once contact the authority inviting the tender for clarification before the submission of the tender.

26. Before tendering, the bidders are advised to inspect the site of work and the environments and be well acquainted with the actual working and other prevalent conditions, facilities available, position of material and labour. No claim will be entertained later, on the ground of lack of knowledge.
27. In the event of expiry or in capacitance of a tenderer after submission of the tender, BHEL may at their discretion cancel their offer/quotation.
28. The tenderers can visit BHEL on working days during office working hours for any clarifications before submitting their offer.
29. BHEL reserves the right to reject any tender on the basis of unsatisfactory performance of the bidder in any ongoing job or any similar job in the past.
30. The following points shall be taken note while quoting the rates:
 - a) The rate quoted shall be firm throughout the period of contract and extended contract period also. No cost escalation is allowed on any account.
 - b) Contractor should not claim for any variation in quantity.
 - c) At the end of completion, the contract may be extended on mutual agreement.
31. Vendor shall visit the Plant before submitting the offer to get to know the location for deploying adequate and suitable personnel for the works & also the equipment.
32. Possession of PF registration number is not mandatory. However, the successful tenderer has to register with PF authorities and furnish the registration number before first Running Account Bill.
33. Incomplete offers shall become liable for rejection.
34. EMD by the tenderer will be forfeited if
 - a) After opening the tender, the tenderer revokes his tender within the validity period or increases his earlier quoted rates,
 - b) The tenderer does not commence the work within the period as per LOI/Contract. In case the LOI/ Contract is silent in this regard then within 15 days after award of contract.
35. All entries in the tender documents should be in one ink. Erasures and over-writings are not permitted. All correspondences and insertions should be duly signed by the tenderers

(signature & seal of bidder)



Bharat Heavy Electricals Limited
(A Government of India Undertaking)
Boiler Auxiliaries Plant
Ranipet-632406

Ref No. 975522072E

concerned. Tenderer has to put sign and seal at the bottom right side in all the pages of tender documents.

36. The tenderer should fill and sign the “checklist of this Tender document” which forms part of the technical bid.
37. Conditional tenders, tender containing absurd rates and amounts, tenders which are incomplete or otherwise considered defective and tenders not in acceptance with the tender conditions laid down by the Accepting Officer, are liable for rejection.
38. If a tenderer expires after submission of his offer, the Bharat Heavy Electricals Ltd, may be at their discretion to reject such offer.
39. BHEL reserves the right to negotiate with L1 bidder.
40. Tenderers shall not increase their quoted rates in case BHEL negotiate for reduction of rates, such negotiations shall not amount to cancellation or withdrawn of the original offer and the rates originally quoted shall be binding on the tenderers for a period of three months from the date of opening of tenders.
41. **MSE CLAUSE:** - MSE suppliers can avail the intended benefits only if they submit attested copies of UDYAM certificate/Start Up certificate by DPIIT along with the offer. Non submission of such documents will lead to consideration of their bid at par with other bidders. No benefit shall be applicable for this enquiry if any deficiency in the above required documents are not submitted before price bid opening. The above required documents are to be uploaded on e-procurement portal.
42. The tenderer should be present if called for negotiation. In case, the tenderer’s authorized person is attending the negotiation such person should have the authorization letter and he should be capable of taking spot decisions.
43. Discrepancy in “words “& “Figures “:
 - a) If, in the price structure quoted for the required goods/services/works, there is discrepancy between the unit price and the total price (which is obtained by multiplying the unit price by the quantity), the unit price shall prevail and the total price corrected accordingly, unless in the opinion of the purchaser there is an obvious misplacement of the decimal point in the unit price, in which case the total price as quoted shall govern and the unit price corrected accordingly.

(signature & seal of bidder)



Bharat Heavy Electricals Limited
(A Government of India Undertaking)
Boiler Auxiliaries Plant
Ranipet-632406

Ref No. 975522072E

- b) If there is an error in a total corresponding to the addition or subtraction of subtotals, the subtotals shall prevail and the total shall be corrected; and
- c) If there is a discrepancy between words and figures, the amount in words shall prevail, unless the amount expressed in words is related to an arithmetic error, in which case the amount in figures shall prevail subject of (a) and (b) above.
- d) If there is such discrepancy in an offer, the same shall be conveyed to the bidder with target date up to which the bidder has to send his acceptance on the above lines and if the bidder does not agree to the decision of the purchaser, the bid is liable to be ignored.
44. The tenderers are requested to bear in mind the entire operations involved, and the conditions during currency of the contract, and request for rate revision of any kind will not be entertained.
45. BHEL will not be bound by any Power of Attorney granted by the tenderer or on their behalf or changes in the composition of the firm made subsequent to the execution of the contract. They may, however, recognize such power of attorney and changes after obtaining proper legal advice, the cost of which will be chargeable to the contractor concerned.
46. The general and special conditions of contract are complementary to each other and where there is a conflict, the special conditions shall prevail. In regard to matters not covered by the General or Special Conditions of Contract, those contained in the specifications approved by BHEL shall apply.
47. The "GENERAL CONDITIONS AND INSTRUCTIONS TO TENDERERS AND SPECIAL CONDITIONS TO THE TNERER" shall be deemed to form an integral part of contract for the work to be entered into.
48. BHEL reserves the right to accept or reject the lowest or any other tender or accept or reject any part of such tender without assigning any reasons therefor.
49. If a tenderer withdraws his offer after submission or after acceptance, fails to provide the sufficient manpower to carry out works execute the contract in accordance with the instructions of the AGM/M&S or any other official designated by him, the earnest money deposited by him will be forfeited and acceptance of his tender will be withdrawn.

(signature & seal of bidder)



Bharat Heavy Electricals Limited
(A Government of India Undertaking)
Boiler Auxiliaries Plant
Ranipet-632406

Ref No. 975522072E

50. All the information as called for in the various clauses and annexure of tender specification should be furnished. The details so furnished should be complete in all respects and as per the formats prescribed in the Tender specification (Statutory requirement of Contract). The bidder may have to produce original documents for verification, if so decided by BHEL.
51. BHEL reserves the right to reject any offer without assigning any reason whatsoever.
52. Offers received with any deviation or without relevant information are liable to be rejected.
53. Price bids received in any form other than prescribed in PRICE BID are liable to be rejected.
54. The price quoted for this tender must be inclusive of all taxes and duties.
55. The acceptance of the offer by BHEL is based on the EMD within the time limit prescribed by BHEL.
56. AGREEMENT: The tenderer after award of work by BHEL through letter of intent shall execute an agreement in the form and the manner as specified by BHEL on non-judicial stamp paper of value not less than Rs.100/-. The cost of stamp paper will be borne by contractor.
57. Unless the contractor whose tender is accepted, signs the contract agreement within seven days of the date of the order directing him to do so, the amount of EMD already deposited by him will be forfeited and acceptance of his tender shall be withdrawn.
58. STAMPING THE AGREEMENT: The expenses of completing and stamping the agreement are borne by the contractor.
59. For any tender related clarifications contact 04172283043/04172284698. Email Id: arunkumarc@bhel.in, mpcskehar@bhel.in
60. For scope of work /BOQ related queries contact 04172283104. Email Id: kumarn@bhel.in.
61. **The bidder participating in the tender shall visit BHEL and discuss with concerned officials for clear understanding of the work requirement before submitting their offers.**
62. **WCM is arranging this contract as a nodal agency. Execution of work, Bill Certification, Bill passing, Payment, Penalty, Contract closing etc., is the responsibility of end user.**

(signature & seal of bidder)



Special Terms and Conditions of the Contract

1. The minimum safety equipment's required to be provided for the contractor's workmen under this contract are safety boots, leather hand gloves, welding screen, welding/cutting goggles and apron. It is the responsibility of the contractor not only to provide the work force with such safety equipment's at their cost as may be considered necessary for the execution of the work but also to ensure their wearing the above safety appliances, failing which corrective action will be taken by withholding the amount recommended by BHEL /Safety Officials for each violation, which may be released only after compliance of the same. The work shall not be commenced without wearing the above safety appliances. The contractor has to follow the BHEL Safety Rules and Regulations as stipulated from time to time would be followed strictly.
2. As required under the Tamilnadu contract Labour (Regulation and abolition) rules 1975, the contractor will have to obtain the License in advance. This should be produced as and when demanded, if not, appropriate action will be taken against the contractor.
3. Since with effect from 01.11.1990 Provident Fund becomes applicable for engagement of a worker even for a single day, deduction of PF by the contractor has to be ensured. All such contractors have to apply to the PF Commissioner and get a separate code number allotted to them if they have not already been allotted a number or registered elsewhere or they are an exempted establishment having their own PF Trust etc. Proof of deduction as well as remittance of the PF dues to the appropriate authorities has also to be shown and proper records maintained.
4. The contractor has to bring adequate manpower for carrying out and completion of the activities/works that are assigned by the concerned department (M&S) officials specified in the Tender Schedule. If the Contractor is not completing the assigned work in time as specified by BHEL, the same will be completed by BHEL engaging alternate resources and the difference in rate of payment with BHEL overheads will be debited/recovered from the Contractor. If such instance repeats frequently it will be viewed seriously.
5. The Contractor has to apply and provide ESI facilities to all his employees concern. Similarly, the contractor shall cover all his workers under ESI scheme and produce the enrolment/Code number allotted by ESI Authorities. The contractor shall be asked to

(signature & seal of bidder)



Bharat Heavy Electricals Limited
(A Government of India Undertaking)
Boiler Auxiliaries Plant
Ranipet-632406

Ref No. 975522072E

furnish along with the bill each month for having effected payment of both deduction/contribution towards PF/ESI to the concerned statutory authorities.

6. The workmen engaged under this contract shall be covered by a comprehensive insurance scheme in the joint names of the contractor and BHEL. A copy of the attested policy along with premium receipt shall be deposited with BHEL before commencement of work.
7. The contractor shall pay the minimum wages to his workers not less than the wages that are being notified by the Tamilnadu Government under the minimum wages Act applicable for Engineering and Fabrication industry from time to time.
8. The contractor has to ensure payment of the statutory prescribed minimum wages as applicable from time to time and maintain proper records of their timely disbursement. These records would need to be preserved and made available even after the contract is over for any verification by the various statutory authorities.

9. **GST:** -

Registration & GST Rate:

- a) Bidder should indicate GSTIN No. (Copy of GST registration to be enclosed) and PAN No. (copy of PAN to be enclosed).
- b) Tender will be considered/ accepted, if & only if the vendor has a valid GST Registration No.
- c) Central Tax/ State Tax/ Integrated Tax/ Union Territory tax to be quoted as extra in %.
- d) Bidders to ensure correct applicability of Central Tax/ State Tax/ Integrated Tax/ Union Territory tax based on the Inter / Intra state movement Supply of goods and provision services or both.

Invoicing & Payment:

- a) The Tax Invoice for supply of Goods & Services should be raised as per the provision of GST Act & Rules and must compulsorily mention the following: -
 - i) BHEL-RANIPET GSTIN: 33AAACB4146P2ZL or GSTIN of BHEL Nodal Agency as mentioned in NIT or informed subsequently.
 - ii) HSN Code or Service Accounting Code for supply of goods or services.
 - iii) Name & address of supplier
 - iv) GSTIN of Supplier
 - v) Consecutive Serial Number & date of issue

(signature & seal of bidder)



Bharat Heavy Electricals Limited
(A Government of India Undertaking)
Boiler Auxiliaries Plant
Ranipet-632406

Ref No. 975522072E

- vi) Description of goods or services
 - vii) Total value of supply
 - viii) Taxable value of supply
 - ix) Tax Rate – Central Tax & State Tax or Integrated Tax, Cess
 - x) Amount of Tax charged
 - xi) Place of supply
 - xii) Address of delivery if different from place of supply
 - xiii) Signature of authorized signatory
- b) Reimbursement of GST to the vendor is contingent upon complying with the following condition by the service provider: -
- i) Uploading the onward GST Return (GSTR-1) in GSTN Network portal within the statutory time period.
 - ii) Discharging the GST tax liability to the Government.
 - iii) Submission of Tax Invoice to BHEL.
 - iv) Submission of proof of payment of GST to BHEL.
 - v) Availing of Input Tax Credit by BHEL.

Input tax credit:

- a) In case GST credit is delayed/ denied to BHEL, due to non/delayed receipt of goods and/or services and/or tax invoice or expiry of timeline prescribed in GST Law for availing such ITC, or any other reason not attributable to BHEL, GST amount shall be recoverable from Vendor along with interest & penalty levied/ leviable.
- b) In case vendor delays declaring such invoice in his return and GST credit availed by BHEL is denied or reversed subsequently as per GST law, GST amount paid by BHEL towards such ITC reversal as per GST law shall be recoverable from vendor/contractor along with interest & penalty levied/ leviable on BHEL.
- c) In case of discrepancy in the data uploaded by supplier in the GSTN portal or in case of any incomplete work/service, then BHEL will not be able to avail the tax credit and will notify the supplier of the same. Supplier has to rectify the data discrepancy in the GSTN portal or issue credit note (details to be uploaded in GSTN portal).
- d) For any such delay in availing of tax credit for reasons attributable to vendor (as mentioned above), interest as per the GST Act & Rules, along with penalty, if any will

(signature & seal of bidder)



Bharat Heavy Electricals Limited
(A Government of India Undertaking)
Boiler Auxiliaries Plant
Ranipet-632406

Ref No. 975522072E

be deducted for the delayed period i.e. from the month of receipt till the month tax credit is availed, from the running bills.

Penalty for Non-compliance of GST Act: Penalty amount so determined along with GST if applicable thereon shall be recovered from the contractor.

Anti-profiteering Measure: Any reduction in rate of Tax on any supply of goods or services or the benefit of input tax credit shall be passed on to the recipient by way of commensurate reduction in prices.

Other Provisions:

- a) All the terms & conditions of the contract with respect to Taxes & Duties are subject to the new taxation laws introduced from time to time (e.g., GST). The terms & conditions will be modified in accordance with the provisions of new laws (e.g., GST).
- b) In case any changes in taxes and duties as per Gov. Notification (including GST), the same shall be applicable from time to time.
- c) If the Contractor is not registered for any statutory obligation and not liable there to, then a declaration shall be submitted along with offer that they are within the threshold limit.
- d) If any changes in GST (statuary variation) will be to the account of BHEL. But if the variation is effective during the delayed/extended period of execution for reasons attributable to the vendor, the same shall be borne by the contractor only. The required compliance under relevant statue shall be carried out.

10. TERMS AND CONDITIONS WITH REGARD TO COMPLIANCE OF VARIOUS LABOUR LAWS BY THE CONTRACTORS FOR BHEL.

- a) The contractor shall not employ in connection with the work any person who has not completed 18 years of age.
- b) The contractor shall in respect of labour employed by him either directly or through sub-contractors, comply with or cause to be complied with the following statutory provisions and rules and in regard to all matters provided therein.
 - i) The contract labour (Regulation and abolition Act 1970) and the related Central Rules 1971.
 - ii) The minimum wages Act 1948 and the related Tamilnadu Rules.
 - iii) The payment of wages Act 1936 and the related Tamilnadu Rules.

(signature & seal of bidder)



Bharat Heavy Electricals Limited
(A Government of India Undertaking)
Boiler Auxiliaries Plant
Ranipet-632406

Ref No. 975522072E

- iv) The Factories Act 1948 and the related Tamilnadu Rules.
 - v) The Employees Provident Fund and Miscellaneous Provisions Act 1952.
 - vi) The Employees State Insurance Act 1948.
 - vii) The workmen's Compensation Act 1923.
 - viii) The Industrial Dispute Act 1947, and any other law, or modifications to the above or to the rules made there under from time to time.
- c) **REGISTRATION AND LICENSING:** Every contractor shall register his/her name with the welfare section of BHEL before taking up the work awarded to him/her by giving the following information and getting a code number:
- i) The name of the contractor.
 - ii) Nature of contract work.
 - iii) Period of work.
 - iv) Number of maximum labour employed by him on any one day.
 - v) License No. and date (applicable in case of contractors employing 20 or more worker)
 - vi) Whether enrolled for PF, ESI etc., and enrolment No. (contractor shall obtain their own PF code)
- This information is called for the purpose of informing the inspector of Factories wherever they call for information regarding contracts.
- d) The contractor employing 20 or more workmen is required to obtain license from the authorities (The Deputy Chief Labour Commissioner(Central) Chennai. This license shall be amended and/or renewed wherever there is an increase in the workmen employed by him/her or in the event of contract being extended or renewed. The contractor shall inform the license number to the BHEL management before taking up the work.
 - e) The contractor (Licensed or unlicensed) shall promptly furnish every information and document required by BHEL authorities for the purpose of fulfilling their obligations as principal employer and/or occupier of the factory and shall render all necessary assistance for the same.
 - f) The contractor shall get the contract labourers engaged by him/her insured under workmen's compensation policy from General Insurance Corporation of India.

(signature & seal of bidder)



Bharat Heavy Electricals Limited
(A Government of India Undertaking)
Boiler Auxiliaries Plant
Ranipet-632406

Ref No. 975522072E

- g) The contractor shall ensure that all his workmen are covered under the Employees State Insurance Act and produce the registration number/enrolment number to the welfare section before executing the contract.
- h) The contractor shall also ensure that all his/her workmen are covered under Employees Provident Fund and Misc. Provisions Act 1952.
- i) **Minimum daily wages to be paid by the contractor** (in INR)

Description	For Unskilled Worker	For Semi Skilled Worker (Fresh ITI)	Skilled Worker (ITI Holder with 3 years' experience/Diploma Holder/ BE holder)
Basic Pay as on 01.04.2022	255.00	265.00	273.50
Dearness allowance as on 01.04.2022	236.19	236.19	236.19
BHEL Adhoc per day	106.77	126.00	141.38
Total wage per day	597.96	627.19	651.08
PF contribution@13% on total wages by employer*	77.74	81.54	84.64
ESI contribution@3.25% on total wages by employer	19.43	20.38	21.16
Bonus @8.33% on (Basic + DA)	40.92	41.75	42.46
EL Portion per day	29.90	31.36	32.55
Total amount	765.94	802.22	831.89

During contract period, Adhoc amount for contract workmen will be subsumed with any increase in Dearness Allowance / Basic wages. After subsuming of BHEL Adhoc fully, any further increase in minimum wages declared by State Govt. will have to be borne by the contractor.

The statutory requirements like PF, ESI will be applicable for the actual total wage per month inclusive of BHEL Adhoc. Bonus amount will be as per bonus act. Contractor quoted rate shall be inclusive of all the above payments including statutory payments thereon

- j) Payment of Bonus to be ensured as per Bonus act. The contractor has to pay the wages to their workers through worker's Bank account only.

(signature & seal of bidder)



Bharat Heavy Electricals Limited
(A Government of India Undertaking)
Boiler Auxiliaries Plant
Ranipet-632406

Ref No. 975522072E

- k) The contractor has to pay the wages to their workers through worker's Bank account only. no hand payment will be acceptable.
- l) The statutory requirements like PF (with sealing of Rs. 15,000), ESI will be applicable for the actual total wage per month inclusive of BHEL Adhoc. Contractor quoted rate shall be inclusive of all the above payments including statutory payments thereon.
- m) The contractor shall ensure payment of wages to the contract labour employed by him/her within three days from the end of wage period in case the wage period is one week or a fortnight & in all other cases before 10th day of the following month.
- n) All payment of wages shall be made on working days at the work site and during the working time and on dates notified in advance. In case the work is completed before the expiry of the wage period final payment shall be made within 48 hours of the last working day.
- o) Where the employment of any worker is terminated by or on behalf of the contractor, the wages earned by him shall be paid before the expiry of the second working day from the day on which his employment is terminated.
- p) Wages due to every worker shall be paid to him direct or to the person authorized by him in this behalf. All wages shall be paid in current coin or currency or in both.
- q) The contractor shall ensure the disbursement of wages in the presence of such authorized representatives of BHEL management.
- r) The above payment shall be verified by the authorized officers/representatives of BHEL with the following certificate on the payment sheet certified that the amount shown in column No. has been paid to the workmen concerned in my presence on
. at
- s) A certificate of payment shall be furnished in duplicate by the contractor to the Engineer In-charge each month.
- t) A notice showing the wage period and the place and time of disbursement of wages shall be displayed at the place of work and a copy to be sent to the welfare department by the contractor under acknowledgement.
- u) Notices showing the rates of wages, weekly rest days, hours of work, wage period, date of payment of wages, names and addresses of the inspectors having jurisdiction, the date of unpaid wages shall be displayed in Tamil and English in conspicuous places at

(signature & seal of bidder)



Bharat Heavy Electricals Limited
(A Government of India Undertaking)
Boiler Auxiliaries Plant
Ranipet-632406

Ref No. 975522072E

the establishment and working by the contractor. The contractor shall inform the BHEL management every month the details of contract labour engaged for each contract in the following form.

- i) Serial Number
- ii) Location
- iii) Period of work
- iv) No. of contract labour engaged during the month
- v) No. of days worked
- vi) No. of man days worked
- vii) Wages paid to his/her workers

The above statement shall be furnished to BHEL management at the end of every month

- v) The following documents/formats under Contract Labour (Regulation and Abolition) Act 1970 and related Central Rules 1971 shall be maintained by each contractor.
 - i) Register of persons employed by the contractor.
 - ii) Employment Card.
 - iii) Service Certificate.
 - iv) Muster Roll, Wage Register, Deduction Register, Wage slip, Over time Register, Register of fines, Register of advances etc.,
- w) The contractor shall display the abstract of the contract labour (Regulation and application) Act and the rules there under both English and Tamil.
- x) Half yearly return shall be sent by the contractor in duplicate to the licensing officer.
- y) The contractor shall submit the returns required under the Contract Labour (Regulation and Abolition) Act 1970 periodically to BHEL management.
- z) The contractor shall without fail give up to date information in writing of the attendance of the workers employed by him/her.
- aa) The contractor shall ensure that his/her workers keep and produce their employment card when coming to duty and take them back when leaving duty.
- bb) All the above registers and records shall be preserved in original for a period of three years. All the registers, records and notice maintained under the Act and Rules shall be produced on demand by Inspector or any Authority under the Act.

(signature & seal of bidder)



Bharat Heavy Electricals Limited
(A Government of India Undertaking)
Boiler Auxiliaries Plant
Ranipet-632406

Ref No. 975522072E

- cc) No workers shall be required or allowed to work on Sunday unless he has or will have a Holiday or any one of the three days before or after the said day.
- dd) The contractor shall inform BHEL Management in the prescribed form details or the contract workers scheduled to work on Sunday, the day of rest and also indicate the substituted holiday in lieu thereof. This shall be intimated two days in advance before his/her workmen are booked for work on Sunday.
- ee) The contract labour working for more than nine hours in any day or for more than 48 hours in any week shall be paid wages at the rate of twice the ordinary rates of wages in accordance with the provisions of section 59 of the Factories Act 1948 and any amendment thereof.
- ff) The contractor shall provide all safety devices and personal protective equipment to his workmen at his/her own cost and shall ensure that his workmen wear/use such devices or equipment provided to them while doing the work and there should not be any relaxation on this.
- gg) The contractor shall give four paid national holidays to his workers, viz 26th January, 1st May, 15th August and 2nd October. The contractor shall ensure that his/her workmen vacate the premises after the shift is over.
- hh) The contractor shall give leave with wages to his/her workmen who have worked for a period of 240 days or more in the factory premises during a calendar year. This leave shall be allowed during the subsequent calendar year at the rate of one day for every 20 days or work performed by the worker during the previous calendar year. The worker whose service commences on a day other than the first of January shall be entitled to leave with wages at the above rate (one day for every 20 days or work) only if he had worked for a minimum of 2/3 of the total number of days in the remainder of the calendar year. This leave will be admissible only during the subsequent calendar year.
- ii) The contractor shall comply with the provisions relating to welfare and health facilities as provided to the Contract Labour (Regulation and Abolition) Act 1970 read with the Tamilnadu contract labour Rules.
- jj) Notwithstanding anything contrary to this, in the event of accident the contractor shall be required to fill injury report and submit the Engineer In-charge immediately and

(signature & seal of bidder)



Bharat Heavy Electricals Limited
(A Government of India Undertaking)
Boiler Auxiliaries Plant
Ranipet-632406

Ref No. 975522072E

ensure the compliance of ESI/Workmen's Compensation Act, Factories Act and Rules made there under. He shall also maintain a register of accident as per the Act.

- kk) The contractor shall get the contract labour engaged by him insured under Workmen's Compensation Policy from General Insurance Corporation of India before actually starting the work of contract. The insurance coverage should be for the entire period of contract. The contractor shall comply with the provisions of the Workmen's Compensation Act 1923 (This should be read in connection with the provisions of ESI Act).
- ll) The contractor shall ensure that all his workmen are covered under the Employees State Insurance Act and produce to BHEL such Registration number/Enrolment number before executing the contract work.
- mm) The contractor shall regularly pay the amount of contribution i.e., employer's contribution as well as employees' contribution in pursuance of the above scheme as fixed from time to time. The contribution payable presently is 0.75% of wages to be recovered from his/her workmen and 3.25% of wages to be contributed by the contractor. Contribution recovered from employee and contribution made by the contractor may be rounded to the next higher multiples of five paise.
- nn) The contractor shall take note of any amendment that may be brought forth in the above contribution rate and act accordingly.
- oo) The contractor shall ensure that his/her workmen are covered under the EPF and miscellaneous Provisions Act 1952 and accordingly produce to the BHEL Management the registration/enrolment number before award of contract work.
- pp) All employees are eligible to become a member of provident fund from the date of joining the establishment and the worker and contractor contributions are 12% and 13% respectively. The contractor is also liable to pay any administrative charges in this behalf that may be decided from time to time. It will be the responsibility of the contractor to ensure such contribution payable in respect of workmen employed through sub-contractors also.
- qq) The contractor shall take note of any amendment in the rate of contribution payable under the scheme from time to time.

(signature & seal of bidder)



Bharat Heavy Electricals Limited
(A Government of India Undertaking)
Boiler Auxiliaries Plant
Ranipet-632406

Ref No. 975522072E

- rr) The contractor shall within seven days of the close of every month submit to BHEL a statement showing the amount of contribution payable/paid for employees engaged by him or through him and shall also furnish to BHEL such information, as principal employer is required to furnish under the provisions of the ESI Act and PF as well as the scheme made there under to the authorities concerned.
- ss) Whenever any sum of money is found to be recoverable from or payable by the contractor under the above acts, the same shall be deducted from any sum that may be due or which at any time thereafter may become due to the contractor under this contract or under any other contract or from his security deposit. In case the recoveries are not sufficient to satisfy the claims the contractor shall pay the balance thereof on demand. In case any recoveries are made under this clause from the security deposit the contractor shall immediately thereafter pay such further sums as may be required to recoup the shortage caused by such recoveries in the amount of security deposit.
- tt) The contractor shall abide by all the labour and other laws applicable to contract labour/worker under this contract and shall at all times keep BHEL, indemnified against all losses, claims, prosecution under any law.
- uu) In case of noncompliance of any of the provisions of the acts and in case BHEL having complied with the same, BHEL will be entitled to recover the same from the contractor/sub-contractor.
- vv) Non exercise of any of the powers or rights available to BHEL hereunder or under any law, shall not in any way operate as waiver thereof.
- ww) Contractor should follow all the provisions of labour legislation and statutory obligations. Provisions as and when amended will also apply.
11. WCM is arranging this contract as a nodal agency. Execution of work, Bill Certification, Bill passing, Payment, Penalty, Contract closing etc. is the responsibility of end user.
12. BHEL reserves the right to reduce the contract period (pre-close the contract), with 7 days' notice period depends on the requirement / without assigning any reason. Security Deposit will be refunded, if the contract is pre-closed for non-requirement by BHEL.
13. The contractor should have to arrange police verification certificate of concern workers (whom they are going to be engaged for these works) for obtaining entry pass.

(signature & seal of bidder)



14. SAFETY PRECAUTIONS TO BE TAKEN BY THE CONTRACTOR

- a) The Contractor must inspect the area of work to decide the safety precautions necessary for executing this contract.
- b) Whenever people work at height more than six feet, platform shall be provided or the workers shall wear safety belt to avoid fall from the height.
- c) Wherever any area declared as dangerous, the workers shall not be allowed to work till a written clearance is obtained from appropriate authorities.
- d) No material of any kind shall be dropped or allowed to be dropped from any height.
- e) Defective ladders shall not be used at all.
- f) Inflammable materials shall not be stored near places where the sparks are likely to occur.
- g) The necessary safety equipment such as gloves, boots, helmets etc. must be issued to the workmen at contractor's cost and strictly to be used while carrying out the work.
- h) Appropriate safety equipment (like safety boots, gloves, goggles, helmet etc.) are to be supplied by the contractor for his workers from day one onwards and should be used during all processes. If the contractor's workers found violating the safety precautions, punitive action will be taken and or a penalty of Rs.500/- to Rs.1000/- will be imposed and deducted from the contractor bill for each violation.
- i) The working area shall be kept clean and free from all obstructions.
- j) All temporary electrical connections shall be properly earthed, insulated and periodically checked.
- k) The contractor should arrange WORKMEN COMPENSATION/ INSURANCE POLICY covered for all his/her workmen (who are not covered by ESI). A copy of the policy has to be submitted before commencement of work.
- l) All safety precautions are to be taken by the contractor at his cost.

These safety measures shall be deemed to form an integral part of the Work Order/ Agreement.

15. The contractor's responsibility for this contract shall commence from the date of issue of order of acceptance of his tender or as per concerned department instructions.



Bharat Heavy Electricals Limited
(A Government of India Undertaking)
Boiler Auxiliaries Plant
Ranipet-632406

Ref No. 975522072E

16. Unless the contractor whose tender is accepted, signs the contract agreement within seven days of the date of the order directing him to do so, the amount of EMD already deposited by him will be forfeited and acceptance of his tender shall be withdrawn.
17. BHEL will not bound by any power of Attorney granted by the tenderer or changes in the composition of the firm made subsequent to the execution of the contract. They may, however, recognize such power of attorney and changes after obtaining proper legal advice, the cost of which will be chargeable to the contract concerned.
18. Words imparting the singular number shall have deemed to include the plural number and vice versa where the context so require.
19. The expenses for completing and stamping the agreement shall be to the contractor's account.
20. The general and special conditions of contract are complementary to each other and where they are in conflict, the special conditions shall prevail. In regard to matters not covered by the General or Special conditions of contract, those contained in the specifications approved by BHEL, shall apply.
21. The "GENERAL CONDITIONS OF CONTRACT" and "SPECIAL CONDITIONS OF THE CONTRACT" shall be deemed to form an integral part of contract for the work to be entered into.
22. The filled ESI declaration forms shall be submitted to the Executive of HRM Dept. In the Declaration Form full address of the contractor shall be mentioned. Whenever a fresh and unregistered worker is engaged during the operation of contract, declaration form in respect of that workman which should be submitted to Human Resources Department within two days of such engagement.
23. ESI contributions (0.75% employee's contribution + 3.25% employer contribution of the total monthly wages) before 20th day of every following month. Prescribed challans are available at ESI local office, Ranipet (near Sipcot). Contractors who have got their own code number can remit the contributions on that number. Along with the challan copy, the details of remittance shall be submitted to the concerned HRM Executive in the ESI compliance form.
24. The contractor should deduct Provident Fund and ESI amount as per the provisions and amount so deducted along with the matching contribution of the contractor shall be

(signature & seal of bidder)



Bharat Heavy Electricals Limited
(A Government of India Undertaking)
Boiler Auxiliaries Plant
Ranipet-632406

Ref No. 975522072E

remitted to the authorities concerned within the stipulated time. The statement of deduction along with the challans evidencing remittance shall be submitted to Officer-in-charge. If the evidences are not shown, further bills of the contractor will not be paid. BHEL have the right to withhold the payment of his bills. Submission of statutory returns such as Half Yearly returns of ESI (Form 6), P.F. return (Form 12A), Form 5 and Form 10, Form 3A & Form 6A should be send to the concerned officers in time.

25. The workers" particulars such as Name, Age, Father's name, address, Phone no, etc., and their daily attendance have to be maintained by the contractor. The details of Provident Fund and ESI compliance have to be maintained by the contractor in the prescribed format/register.

26. The contractor shall maintain the following Registers and Records and make them available for inspection at any time. (The list is only for example, but not exhaustive).

- a) Muster Roll
- b) Register of Wages
- c) Register of Deductions
- d) Register of Overtime
- e) Register of Fine
- f) Register of Advance
- g) Wage slips
- h) Register of Accidents
- i) Register of Leave with Wages
- j) ESI Register in Form-7

All registers are required to be maintained as above and shall be produced as and when Government Officials and Statutory Authorities to make inspection from time to time.

27. In case a contract labourers meets with an accident while on duty, the contractor shall immediately intimate the information to Safety Department, Contracting Agency and Human Resources Department and submit the Accident Report duly filled in all respect and send a copy to ESI local office, ESI Dispensary and Inspector of Factories (for major accidents) within 24 hours of accident through Safety and Human Resources Departments. All assistance for the injured workman such as to taking him to ESI Dispensary for treatment must be rendered by the contractor.

(signature & seal of bidder)



Bharat Heavy Electricals Limited
(A Government of India Undertaking)
Boiler Auxiliaries Plant
Ranipet-632406

Ref No. 975522072E

28. Compliance of the above provisions does not absolve the obligation of contractor arising out of other statutory obligations.
29. Contractor should employ only persons having sound health and not above the age of 60 years, and not below the age of 18 years.
30. The Contractor agrees that no claim for interest or damages will be entertained or be payable by BHEL in respect of any money or balances or amounts of whatsoever nature which may be lying with BHEL owing to any disputes or differences between the parties irrespective of whether the same is decided by any authority to be paid or returned to the Contractor."
31. BHEL reserves the right to reduce the contract period (pre-close the contract), with 7 days' notice period depends on the requirement / without assigning any reason. Security Deposit will be refunded, if the contract is pre-closed for non-requirement by BHEL.
32. Certificate by the executing department that all statutory requirements including PF, ESI, Minimum wages, Insurance, GST, etc. are complied with by the Contractor. This should be duly backed by the relevant documents".
33. If the contractor is not able to provide the sufficient manpower for a period of continuous period of 15 days, BHEL reserves the right to terminate the contract and to take appropriate action against the contractor. In the event of contract termination, security deposit paid by the contractor will be forfeited.
34. **Penalty Terms:** To claim compensation for losses sustained including BHEL's supervision charges and overheads for completion on termination of contract and to impose penalty for delay in completion of the work against the delivery date mentioned in PO copy is imposed at the rate of ½% of the respective PO value per week of delay or part thereof subject to a ceiling of 10% of the respective PO value.
35. **Payment Terms:** Monthly post payment shall be paid based on the actual work done by the contractor as per BOQ after Certifying by engineer in charge and duly submit the necessary statutory documents (PF, ESI). For MSE vendor payment will be made within 45 days and for non-MSE payment will be made within 60 days (GEM Tenders) and for others the payment will be made within 90 days from the date of bill submission along with all supporting documents.

(signature & seal of bidder)



Bharat Heavy Electricals Limited
(A Government of India Undertaking)
Boiler Auxiliaries Plant
Ranipet-632406

Ref No. 975522072E

36. In case of breach of any or whole of the above terms and conditions by the contractor BHEL will have the liberty to cancel the registration and contract either in part or in full and entrust in part or in full of the work to any contractor and the contractor shall be liable to pay extra cost involved in the execution of cancelled part of the contract.

(signature & seal of bidder)



General Conditions of Contract

1. **DEFINITION**: - In these General Conditions of Contract, the following terms shall have the meaning hereby assigned to them, except where the context otherwise requires: -
- a) The “Contract” means, the documents forming the tender and acceptance thereof, together with all the documents referred to therein including general and special conditions to contract. All these documents as applicable taken together shall be deemed to form one contract and shall be complementary to one another.
 - b) The “Work” means, the work described in the tender documents in individual work-orders as may be issued from time to time to the contractor by the officer-in charge with in the power conferred upon him including all notified or additional items of works and obligations to be carried out as required for the performance of contract.
 - c) The “Contractor” means, the individual firm or company whether incorporated or not, undertaking the work and shall include the legal personal representatives of such individuals or the persons composing the firm or company or the successors of the firm or company and the permitted assigns of such individual or firm or company.
 - d) “The officer-in charge” means, the officer deputed by the AGM/WCM to supervise the work or part of the work.
 - e) “Approved” and “Directed” means, the approval or direction of AGM/WCM, or person deputed by him for the particular purposes.
 - f) “BHARAT HEAVY ELECTRICAL LIMITED” (herein after referred to as BHEL) shall mean the Board of Directors, Chairman, Executive Director, General Manager or other administrative office of the said company including AGM/WCM authorized to invite tenders and enter into contract for works on behalf of the company.
 - g) The “Contract sum” means, the sum accepted or the sum calculated in accordance with the prices accepted in tender and / or the contract rates as payable to the contractor for the execution of work during the currency of the contract.
 - h) A “week” means, seven days, without regard to the number of hours worked or not worked in any day in that week.
 - i) A “day” means, the day of 24 hours (Twenty-Four) irrespective of the number of hours worked or not worked in that day.

(signature & seal of bidder)



Bharat Heavy Electricals Limited
(A Government of India Undertaking)
Boiler Auxiliaries Plant
Ranipet-632406

Ref No. 975522072E

j) A “working day” means, any day other than that prescribed by the NEGOTIABLE INSTRUMENTS ACT as being a holiday, and consists of the number of hours of labour as commonly recognized by good employers in the trade in the district where the work is carried out or as laid down in the BHEL regulation.

2. **HEADING TO THE CONTRACT CONDITIONS:** -

The heading to these conditions shall not affect the interpretations thereof.

3. **WORK TO BE CARRIED OUT:** - The contract shall, include all labour, materials, tools, plant, equipment and transport which may be required for the execution of work. The contractor will be deemed to have satisfied himself as to the nature of the site, local facilities of access and all matters affecting the execution of work. No extra charges consequent on any misunderstanding in these respects or otherwise will be allowed.

4. **DEVIATIONS:** - The contractor shall not carry out any work not covered by schedule except in the pursuance of the written instructions of AGM/WCM. No such work shall be valid unless the same has been specifically confirmed and accepted by the BHEL in writing and incorporated in the contract.

5. **OCTROI AND OTHER DUTIES:** - All charges on account of octroi terminal or sales tax or other duties on materials obtained for the work shall be borne by the contractor.

6. **PLANT AND EQUIPMENT:** - The contractor shall at his own expense, supply all tools, plant and equipment (herein after referred to as T&P) required for the execution of the contract.

7. **ASSIGNMENT OF TRANSFER OF CONTRACT:** -The contractor shall not without the prior written approval of the BHEL, assign or transfer the contract or any part thereof, or any share, or interest thereon to any other persons. No sum of money which may become payable under the contract shall be payable to any person, other than the contractor unless the prior written approval of the BHEL to the assignment or transfer of such money is given.

8. **SUB-CONTRACT:** -The contractor shall not sub-let any portion of the contract without the prior written approval of the BHEL.

9. **COMPLIANCE TO REGULATIONS AND BYE-LAWS:** -The contractor shall confirm to the provisions of any statute relating to the work and regulations and bye-laws of any local authority. The contractor shall be bound to give all notices required by statute regulations

(signature & seal of bidder)



Bharat Heavy Electricals Limited
(A Government of India Undertaking)
Boiler Auxiliaries Plant
Ranipet-632406

Ref No. 975522072E

or by-laws as aforesaid and to pay all fees and taxes payable to any authority in respect thereof.

10. **SECURITY DEPOSIT:** -SECURITY DEPOSIT shall be collected from the successful tenderer. The total amount of security deposit will be 5% of the contract value. EMD of the successful tenderer shall be converted and adjusted towards the required amount of Security Deposit.

Mode of Deposit:

- a) Cash (as permissible under the extant Income Tax Act).
- b) Local Cheque of Scheduled Banks (subject to realization)/ Pay Order/ Demand Draft/ Electronic Fund Transfer in favour of BHEL.
- c) Bank Guarantee from Scheduled Banks/ Public Financial Institutions as defined in the Companies Act. The Bank Guarantee format should have the approval of BHEL.
- d) Fixed Deposit Receipt issued by Scheduled Banks/ Public Financial Institutions as defined in the Companies Act (FDR should be in the name of the Contractor, a/c BHEL).
- e) Securities available from Indian Post offices such as National Savings Certificates, Kisan Vikas Patras etc. (held in the name of Contractor furnishing the security and duly endorsed/ hypothecated/ pledged, as applicable, in favour of BHEL).

(Note: BHEL will not be liable or responsible in any manner for the collection of interest or renewal of the documents or in any other matter connected therewith).

At least 50% of the required Security Deposit, including the EMD, should be collected before start of the work. Balance of the Security Deposit can be collected by deducting 10% of the gross amount progressively from each of the running bills of the Contractor till the total amount of the required Security Deposit is collected.

If the value of work done at any time exceeds the contract value, the amount of Security Deposit shall be correspondingly enhanced and the additional Security Deposit shall be immediately deposited by the Contractor or recovered from payment/s due to the Contractor.

(signature & seal of bidder)



Bharat Heavy Electricals Limited
(A Government of India Undertaking)
Boiler Auxiliaries Plant
Ranipet-632406

Ref No. 975522072E

The recoveries made from running bills (cash deduction towards balance SD amount) can be released against submission of equivalent Bank Guarantee in acceptable form, but only once, before completion of work, with the approval of the authority competent to award the work.

EMD of the successful tenderer will be converted and adjusted against security deposit.

EMD and security deposit shall not carry any interest.

11. Security deposit shall be refunded only after successful completion of the contract and after completion of warranty period of Six months to BHEL's satisfaction and presents an absolute "No Demand Certificate" in the prescribed form and returns properties belonging to BHEL handed over, lent or hired by him for carrying out the said works, Security Deposit will be released to the Contractor after deducting all cost of expenses or other amounts that are to be paid to BHEL under this or other contracts entered into with the Contractor. It may be noted that in no case the Security Deposit shall be refunded/released prior to passing of final bill.
12. Should a tenderer or a contractor has a relative or in the case of a firm or company of contractors, any of its shareholders or shareholder's relative, employed in Bharat Heavy Electricals Ltd, the authority inviting tenders shall be informed of this fact at the time of submission of the offer, failing which the offer may be disqualified or if such fact subsequently come to light, the contract may be cancelled.
13. BHEL shall not be responsible for any loss of securities, due to liquidation for any other reasons, what-so-ever or any depreciation in the value of the securities while in their charge or for any loss of interest there on.
14. All compensation or other sums of money payable by the Contractor to BHEL under the terms of this contract or under any other contract with BHEL may be deducted from the Security Deposit or realised by the sale of the securities or from the interest arising therefrom or from any sums which may be due or may become due to the contractor by BHEL and in the event of this Security Deposit being deducted by reason of such deductions or sale, as aforesaid, the Contractor shall within 7 days thereafter, make good in cash or in securities endorsed as aforesaid, any sum by which the Security Deposit has been reduced.

(signature & seal of bidder)



Bharat Heavy Electricals Limited
(A Government of India Undertaking)
Boiler Auxiliaries Plant
Ranipet-632406

Ref No. 975522072E

15. **ORDERS UNDER THE CONTRACT:** -All orders, notices etc. to be given under the contract shall be in writing, type-script or printed and if sent by registered post to the address given in the tender of the contract, shall be deemed to have been served on the date, when in the ordinary course they would have been delivered to him.
16. **CONTRACTOR'S SUPERVISION:** -The contractor shall either himself supervise the execution of the contract or shall appoint a complement agent acceptable to the AGM/WCM to act in his stead. Orders given to the contractor's agent shall be considered to have the same force as if they have been given to the contractor himself. The contractor or his accredited agent shall attend when required without making any claim for doing so, either the office of the AGM/WCM or the OFFICE-IN CHARGE, to received instructions.
17. The AGM/WCM shall have full powers and without assigning any reason, required the contractor to immediately cease to employ in connection with this contract, any agent, servant or employee where continued employment is in his opinion undesirable. The contractor shall not be allowed any compensation on this account.
18. **LABOUR:** -The contractor shall remain liable for the payment of all wages or other moneys to his work people or employees under the payment of wages act 1936, Employees Liability Act 1938, Workmen Compensation Act 1923 or any other Act or enactment, relating thereto and rules framed, thereunder from time to time.
19. **PRECAUTIONS UNDER RISK:** -The contractor shall be responsible for providing at his own expense for all precautions to prevent loss or damage from any and all risks and to minimize the amount of any such loss or damage and for the necessary steps to be taken for the said purposes.
20. **DAMAGE & LOSS TO PRIVATE PROPOERTY & INJURY TO WORKMEN:** -The contractor shall at his own expenses reinstate and make good to the satisfaction of the AGM/WCM and pay compensation for any injury, loss or damage occurred to any property or rights whatever including property and rights of BHEL (or agents) servants or employee of BHEL, the injury loss or damage arising out of or in any way in connection with the execution or purported execution of the contract and further the contractor shall indemnify, the BHEL against all claims enforceable against BHEL (or any agent, servant or employee of BHEL) or which would be so enforceable against BHEL where BHEL is a private person, in respect of any such injury (including injury resulting I death) loss or damage to any person

(signature & seal of bidder)



Bharat Heavy Electricals Limited
(A Government of India Undertaking)
Boiler Auxiliaries Plant
Ranipet-632406

Ref No. 975522072E

whomsoever or property including all claims which may arise under the workmen's compensation act or otherwise.

21. **LAWS GOVERNING THE CONTRACT:** -The contract shall be governed by the India laws for time being in force.

22. **CANCELLATION OF CONTRACT FOR CORRUPT ACTS:** -BHEL, whose decision shall be final and conclusive, shall without prejudice to any other right or remedy which shall have accrued shall accrue thereafter to BHEL cancel the contract in any if the following cases and the contractor shall be liable to make payment to BHEL for any loss or damage resulting from any such cancellation to the same extent as provided in the case of cancellation for default.

If the contractor shall: -

a) Offer or give or agree to give to any person in BHEL service any gift or consideration of any kind, as an inducement or reward for doing or for bearing to do or for having done or for borne to do any act, in relation to the obtaining or execution of this or any other contract for BHEL service.

(OR)

b) enter in to a contract with BHEL in connection with which commission has been paid or agreed to be paid by him or with his knowledge, unless the particulars of any such commission and the terms of payment thereof have previously been disclosed in writing to BHEL.

(OR)

c) obtain a contract with BHEL as a result of ring tendering or by non-bonfire methods of competitive tendering, without first disclosing the fact in writing to BHEL.

23. **RISK PURCHASE CLAUSE AS PER BHEL SOP DT. 10.10.2017:** - If the contractor fails to carry out the specified works as per the contract scope of work within the timeframe as directed by AGM/WCM or his authorized officials and continues in that state after a reasonable notice from AGM/WCM or his authorized officials, BHEL reserves the right to have the work done by any means at the Contractor's risk and expenses provided always that in the event of the cost of the work so done (as certified by authorized officials of Shipping/ Stores/ M&S which is final and conclusive) being less than the contract cost, the advantage shall accrue to the BHEL and if the cost exceeds the money due to Contractor under the

(signature & seal of bidder)



Bharat Heavy Electricals Limited
(A Government of India Undertaking)
Boiler Auxiliaries Plant
Ranipet-632406

Ref No. 975522072E

contract, the Contractor shall either pay the excess amount ordered by AGM/WCM or the same shall be recovered from the Contractor by other means.

24. CANCELLATION OF CONTRACT FOR INSOLVENCY ASSIGNMENT OF TRANSFER OR

SUBLETTING OF CONTRACT: - BHEL, without prejudice to any other right or remedy, which shall have accrued or shall accrue thereafter to BHEL shall cancel the contract in any of the following cases:

If the contractor,

- a) being an individual or if a firm any partner thereof shall at any time be adjudged bankrupt or have a receiving order for administration of his estate, made against him or shall take any proceedings for liquidation or composition under any bankruptcy Act or assignment of his effects of composition or arrangement for the benefit of his creditors or purport to do so, or if any application made under any Bankruptcy Act for the time being in force for the sequestration of his estate or if a trust deed be granted by him on behalf of his creditors

(OR)

- b) being a Company, shall pass a resolution or the Court shall make an order for the liquidation of its affairs, or a receiver or Manager on-behalf of the debenture holders shall be appointed or circumstances shall arise which entitle the Court or debenture holders to appoint a receiver or Manager,

(OR)

- c) Assigns, Transfers, Sub-lets or attempts to assign, transfer or sub-let any portion of the work without the prior written approval of the BHEL.
- d) Whenever BHEL exercise the authority to cancel the contract under this conditions, BHEL may have the work done by any means at the Contractor's risks and expenses provided always that in the event of the cost of the work so done (as certified by concerned executive of M&S department which is final and conclusive) being less than the contract cost, the advantage shall accrue to the BHEL and if the cost exceeds the money due to Contractor under the contract, the Contractor shall either pay the excess amount ordered by AGM/WCM or the same shall be recovered from the Contractor by other means.

(signature & seal of bidder)



Bharat Heavy Electricals Limited
(A Government of India Undertaking)
Boiler Auxiliaries Plant
Ranipet-632406

Ref No. 975522072E

- e) In case BHEL carries-out the work under the provisions of this condition the cost to be taken into account in determining the excess cost to be charged to the Contractor under this condition shall consist of the cost of the materials, hire charges of tools and plants and/or labour provided by the BHEL with an addition of such percentage to cover superintendence and establishment charges as may be decided by the AGM/WCM whose decision shall be final and conclusive.

25. CANCELLATION OF CONTRACT IN PART OF FULL FOR CONTRACTOR'S DEFAULT: -If the contractor,

- a) makes default in carrying out the work as directed and continues in that state after a reasonable notice from AGM/WCM or his authorised representative.
- b) fails to comply with any of the Terms and Conditions of the contract or after reasonable notice in writing with orders properly issued thereunder.
- c) BHEL, may without prejudice to any other right or remedy which shall have accrued or shall accrue thereafter to BHEL CANCEL the contract as whole or in part thereof or only such work order or items of work in default from the contract. Whenever BHEL exercise the authority to cancel the contract as whole or part under this condition BHEL may complete the work at the contractor's risk and cost (as certified by concerned executive of M&S department which is final and conclusive) being less than the contract cost, the advantage shall accrue to the BHEL. If the cost exceeds the moneys due to the Contractor under this contract the Contractor shall either pay the excess amount ordered by AGM/WCM or the same shall be recovered from the Contractor by other means. In case the BHEL carries out the work or any part thereof under the provisions of the conditions the cost to be taken into account in determining the excess cost to be charged to the Contractor under this condition shall consist of the cost of the materials, hire charges of tools and plant and/or labour provided by the BHEL with an addition of such percentage to cover the superintendence and establishment charges as may be decided by the AGM/WCM whose decision shall be final and conclusive.

26. TERMINATION OF CONTRACT ON THE DEATH OF CONTRACTOR: -Without prejudice to any of the rights or remedies under this contract, if the Contractor dies, or if the firm is

(signature & seal of bidder)



Bharat Heavy Electricals Limited
(A Government of India Undertaking)
Boiler Auxiliaries Plant
Ranipet-632406

Ref No. 975522072E

dissolved or the company is liquidated BHEL shall have the option of terminating the contract without compensation to the Contractor.

27. **SPECIAL POWER TO TERMINATION**: -If at any time after the award of contract, BHEL shall for any reason whatsoever not require whole or any part of the work to be carried out the AGM/WCM shall give notice in writing of the fact to the Contractor who shall have no claim to any payment of compensation or otherwise howsoever on account of any profit or advantage which he might have derived from the execution of the work in full but which he did not derive in consequence of the fore-closing of the work.

“If any employee/labourer working in the contract is found involved in corruption activities, the contract will be terminated and the contractor will be banned for applying for any future contract for 3 years.”

28. **RECOVERY FROM CONTRACTOR**: -Whenever under the contract, any sum of money, shall be recoverable from or payable by the Contractors, the same may be deducted from or any sum then due or which at any time thereafter may become due to Contractor under the contract or under any other contract with BHEL or from his Security Deposit or he shall pay the claim on demand.

29. **POST TECHNICAL AUDIT OF WORK AND BILLS**: -BHEL reserves the right to carry out the post-payment Audit and technical examination of the work and final bill including all supporting vouchers, abstracts etc., and enforce recovery of any sum becoming due as a result thereof in the manner provided in the presiding sub-paragraphs. However, no such recovery shall be enforced after three years of passing the final bill.

30. **SIGNING OF CONTRACT**: -Each contract document shall be signed by the Contractor with his usual signature. Contract by partnership of Hindu Joint Family firm, may be signed in the FIRM'S name by one of the Partners or the Karta or Manager as the case may be or by any other duly authorised representative followed by the name and designation of the persons so signing. Contracts by a Company shall be signed with the name of the Company by a person authorised in this behalf and a power of attorney or other satisfactory proof showing that the persons signing the Contract documents on behalf of the Company is duly authorised to do so, shall accompany the contract.

31. **FORCE MAJEURE CLAUSE**: -If, at any time during the continuance of this Contract the performance in whole or in part by either party of any obligations under this Contract shall

(signature & seal of bidder)



Bharat Heavy Electricals Limited
(A Government of India Undertaking)
Boiler Auxiliaries Plant
Ranipet-632406

Ref No. 975522072E

be prevented or delayed by reason of any War, Hostile acts of the public enemy Civil Commotion, Epidemics, or Acts of God (Floods, Storm/Cyclone, Hurricane, Earth Quake etc.) then provided notice of happening of any such event is given by either party to other within 7 days from the date of occurrence therefore neither party shall by reason of such event be entitled to terminate this Contract nor shall either party have any claim for damages against the other in respect of such non-performance and delay in performance under the contract shall be resumed as soon as practicable after such event has come to an end or ceased to exist. If the performance in whole or part of any obligation under this Contract is prevented or delayed by reason of any such event, claims for extension of time shall be granted for periods considered reasonable by the AGM/WCM subject to prompt notification by the contractor.

32. ARBITRATION: -All disputes between the parties to the contract, arising out of or relating to the contract, other than those for which the decision of the AGM/WCM or Accepting Officer or any other person is by the contract expressed to be final and conclusive. All disputes between the parties to the Contract, arising out of or relation to the Contract shall after written notice by either party to the Contract to the other party be referred and resolved by an Arbitrator nominated by the Unit Head of BHEL, Ranipet.

Unless the parties otherwise agree, such reference shall not take place until after the completion, alleged completion or abandonment of the work of the determination of the contract. The venue of Arbitration shall be such a place or places as may be fixed by the Arbitrator in his sole discretion. The award of the Arbitrator shall be final, conclusive and binding on both parties to the contract. Subject to the above, Courts at Ranipet alone shall have exclusive jurisdiction of any matter arising in connection with this Agreement.

33. Arbitration and Jurisdiction:

- a) The jurisdiction for any arbitration/settlement of contractual/ legal issues between contractee and contractor, shall only be at the court of Ranipet. Any dispute between BHEL and the Contractor arising out of or in connection with this Contract, other than those for which BHEL decision is final, shall be referred to arbitration by a sole arbitrator to be appointed by BHEL, BAP Ranipet.
- b) The place of Arbitration shall be Ranipet, Tamil Nadu. The arbitrator may hold meetings for convenience at such places as per his discretion.

(signature & seal of bidder)



Bharat Heavy Electricals Limited
(A Government of India Undertaking)
Boiler Auxiliaries Plant
Ranipet-632406

Ref No. 975522072E

- c) The award of the Arbitrator shall be final, conclusive and binding on both parties to the contract
- d) Subject to the above, the courts at Ranipet alone have the jurisdiction to decide any dispute arising out of or in respect of the Contract."

34. CHANGE IN CONSTITUTION OF FIRM: Changes in constitution of firm whenever it is made after submission of application or during currency of the contract, the existing firm has to duly inform the proposed changes to contracting department of BHEL at the appropriate time before the changes in the constitution are made. In case the absence of any such information BHEL is not responsible for the consequences arising out of the absence or suppression of information and the issue / dispute arising out of these changes and the firm is responsible for settling the issue or dispute among themselves (Partners etc.) or with the bankers or with any third party. Under the above circumstances when dispute arises and the firm does not inform the change in the constitution of the firm BHEL has the right for suspending or terminating the contract.

35. FRAUD PREVENTION POLICY: -The Bidder along with its associate/ collaborators/ sub-contractors/ sub-vendors/ consultants/ service providers shall strictly adhere to BHEL Fraud Prevention Policy displayed on BHEL website <http://www.bhel.com> and shall immediately bring to the notice of BHEL Management about any fraud or suspected fraud as soon as it comes to their notice.

36. SECURITY OF CONFIDENTIAL INFORMATION: The Contractor undertakes and agrees that he/it will not disclose or reveal in part or full the proprietary/confidential information, which terms shall mean and include patents, trademarks, service marks, registered designs, copyright, design rights, know-how, confidential information, trade and business names and any other similar protected information of BHEL received during negotiation or currency of the contract to any third party or governmental authorities without written permission from BHEL. In the event of termination or expiry of the contract, the contractor shall return all proprietary/confidential information to BHEL. This clause shall survive termination or expiry of the contract.

All the input details: transmittals and sample drawings supplied for preparation of drawings are confidential information of BHEL for specific purpose only. The contractor shall never pass on / part with the information to anybody and shall maintain the secrecy

(signature & seal of bidder)



Bharat Heavy Electricals Limited
(A Government of India Undertaking)
Boiler Auxiliaries Plant
Ranipet-632406

Ref No. 975522072E

of the information. As soon as the bills are certified by BHEL, all the relevant drawing files shall be erased from PCs and shall not be made use under any circumstances.

BHEL reserves the right to initiate appropriate action including legal proceeds / termination of contract, recovery of damages, penalties etc., if the contractor is found guilty / wrong usage of the documents given by BHEL for any unauthorised activity.

37. **SETOFF CLAUSE:** -"BHEL shall have the right to recover any money which in the sole opinion or BHEL is due from the Contractor from any money due to the Contractor under this Contract or any other contract or from the Security Deposit furnished by the Contractor under this Contract or any other contract. "

38. Notwithstanding anything to the contrary, including, but not limited to, provisions relating to extension of time and compensation/ or delay, time shall be the essence of the contract.

39. "Where the Contractor (whether a proprietorship, partnership, company, Hindus Undivided Family or otherwise) commits a default or breaches the Contract and the proprietor/ partner/director/ member of such entity is also a proprietor/ partner/ director/ member of another entity that is registered with BHEL (in Ranipet or any other unit of BHEL), BHEL shall have the right to recover losses due to the default or breach, whether direct, indirect or consequential, either from the defaulting/ breaching entity or the other said entity or both. Such right shall also include the right to encash any security (in any form such as but not limited to bank guarantee, demand draft, FD, etc.) _ furnished by either or both entities. Without limiting the applicability of the foregoing, it shall not be a defence to the other said entity for enforcement of such a right that:

- (a) both entities are legally distinct/ separate entities, or
- (b) the management of the entity/ partners/ directors/ members of such other entity were not aware that the proprietor/ partner/ director/ member of the defaulting/ breaching entity was also a proprietor/ partner/ director/ member of the other said entity."

40. The Successful Tenderer shall agree to the following conditions: Contractor shall indemnify and keep indemnified BHEL, its other contractors and/or sub-contractors and its/their employees from all actions, proceedings, suits, claims, demands, liabilities, damages, losses, costs, charges, expenses judgments and fines arising out of or in the

(signature & seal of bidder)



Bharat Heavy Electricals Limited
(A Government of India Undertaking)
Boiler Auxiliaries Plant
Ranipet-632406

Ref No. 975522072E

course of, or caused by the execution of work under the Contract or other obligations hereunder directly or indirectly associated herewith which may arise due to:

- a) breach of law by the Contractor, or any of its sub-contractor, or any of their respective employees.
- b) negligence or wilful default by the Contractor, or any of its sub-contractor, or any of their respective employees.
- c) failure by Contractor to proceed with Project in accordance with the determinations, instructions and clarifications of Company pending disagreement, dispute, protest, request for arbitration/ court proceedings.
- d) loss of property or death of any employee of BHEL or of its other contractors/ sub-contractors.

The above shall be without prejudice to any other remedy that may be available to BHEL whether as per law, contract, equity or otherwise. The quantum of work/ nature of work to be carried out by the hired crane will be decided by BHEL from time to time and the availability of the combination of work.

41. All statutory requirements under Minimum Wages Act,1948, Factories Act 1948, Workmen Compensation Act 1923, Employees Provident Fund and Miscellaneous Provisions Act, 1952, Payment of Gratuity Act 1972, Employee State Insurance Act 1948, Contract Labour (R&A) Act 1970, Payment of Bonus Act 1965, Income Tax Act, Service Tax Act and all other applicable Acts shall be complied with by the Contractor.
42. **MOTOR VEHICLE ACT:** The contractor should comply the relevant Motor Vehicle Act and other statutory requirement, if applicable.
43. Contractor shall comply with all statutory requirements, rules, regulations, notifications in relation to employment of his employees issued from time to time by the concerned authorities.
44. Contractor shall indemnify BHEL against all claims and losses under various Labour Laws, statutes or any civil or criminal law in connection with employees deployed by him.
45. Contractor wherever applicable shall maintain proper records prescribed by the concerned statutory authorities and provides a copy of the same to BHEL.
46. Contractor shall furnish proper returns to the concerned statutory authorities and provide a copy of the same to BHEL.

(signature & seal of bidder)



Bharat Heavy Electricals Limited
(A Government of India Undertaking)
Boiler Auxiliaries Plant
Ranipet-632406

Ref No. 975522072E

47. No interest shall be payable by BHEL on Earnest Money/ Security Deposit/ or any money due to the Contractor by BHEL.
48. Time is the essence of contract and hence any delay in Execution of contract will attract penal action by BHEL by deduction of such amounts as may be fixed by BHEL as compensation for the delay of work. This is without prejudice to conditions of contract mentioned elsewhere regarding deduction for taking alternative action / cancellation of contract.
49. BHEL shall recover the amount of compensation paid to victim(s) by BHEL towards loss of life/permanent disability due to an accident which is attributable to the negligence of contractor, agency or firm or any of its employees as detailed below.
- a) Victim: Any person who suffers permanent disablement or dies in an accident as defined below.
- b) Accident: Any death or permanent disability resulting solely and directly from any unintended and unforeseen injurious occurrence caused during the manufacturing/operation and works incidental thereto at BHEL factories/offices and precincts thereof, project execution, erection and commissioning, services, repairs and maintenance, trouble shooting, serving, overhaul, renovation and retrofitting, trial operation, performance guarantee testing undertaken by the company or during any works/ during working at BHEL units/officers/townships and premises/ project sites.
- c) Compensation in respect of each of the victims: (i) In the event of death or permanent disability resulting from Loss of both limbs: Rs.10,00,000/- (Rs. Ten lakh) (ii) In the event of other permanent disability: Rs.7,00,000/- (Rs. Seven lakh) d). Permanent Disablement: A disablement that is classified as a permanent total disablement under the proviso to section 2 (I) of the Employee's Compensation Act, 1923.
50. For every month, the contractor shall prepare & submit bill in the succeeding month within one week from the date of certification of quantity by user dept.
51. Any billing related query, clarification, document requirement, etc. shall be resolved in one go by the Contractor within one week from the date of intimation.
52. **SUBMISSION OF BILLS BY CONTRACTOR:** - The Contractor at the end of each month shall submit a bill in triplicate detailing the various items of work done during the month

(signature & seal of bidder)



Bharat Heavy Electricals Limited
(A Government of India Undertaking)
Boiler Auxiliaries Plant
Ranipet-632406

Ref No. 975522072E

supported by the requisitions issued from time to time. The Contractor shall, once in every month, submit to the concerned executive of M&S department separately details of his claims for the work done by him up to and including the previous month which are not covered by his contract agreement in any of the following respects:

- a. Deviation from the items provided in the contract documents.
- b. Extra items / new items of work.
- c. Items in-respect of which rates have not been settled. He should in addition furnish a clear certificate to the effect that the claims submitted by him as aforesaid cover all his claims and that no further claims shall be raised by him in respect of the work done up to and including the period under report.

53. PAYMENT OF BILLS: - All payments to be made to the Contractor, under this contract shall be by "CHEQUE" crossed "A/C PAYEE ONLY" OR by NEFT / RTGS payment within a reasonable time after the certification of bills by the authorized officials of BHEL.

54. SUSPENSION OF BUSINESS DEALINGS: - The bidder along with its associate / collaborators / sub-vendors / consultants / service providers shall strictly adhere to "Guidelines for Suspension of Business Dealings with Suppliers/ Contractors" AA/MM/SB/01 Rev: 02 amdt. 02, Dt.08.01.2020 displayed on BHEL website <http://www.bhel.com>. (<https://www.bhel.com/guidelines-suspension-business-dealings-supplierscontractors>)

55. BHEL reserves the right to reduce the contract period (pre-close the contract), with 30 days' notice period depends on the requirement / without assigning any reason. Security Deposit will be refunded, if the contract is pre-closed for non-requirement by BHEL.

56. In case of breach of any or whole of the above terms and conditions by the contractor BHEL will have the liberty to cancel the registration and contract either in part or in full and entrust in part or in full of the work to any contractor and the contractor shall be liable to pay extra cost involved in the execution of cancelled part of the contract.

57. Transit insurance will be under BHEL Scope.

(signature & seal of bidder)



DECLARATION

I/We M/s.
have read and clearly understood all the Terms and conditions in Tender Schedule of 9755220XXE and accordingly accept the same without any deviation what so ever.

- ❖ I/ We unconditionally agree to all the tender conditions and no new conditions are imposed by us in the technical / price bid. I understand in the event of imposing any condition in the technical / price bid, such condition would be ignored by BHEL and only the prices will be considered for the purpose of evaluation”
- ❖ I/ We confirm that none of our group concern or affiliates etc., appears on the list of banned firms / companies by BHEL (list available on www.bhel.com) nor any of the Director / Partner / proprietor of bidder / such group concern or affiliate etc. are involved with such company.
- ❖ I/ We also declare that, we have not been suspended or black listed or issued with Show Cause Notice by BHEL- Ranipet or any other BHEL Unit.
- ❖ I/ We confirm that other than us, none of our group concerns or affiliates etc. are participating in the tender either directly or indirectly through any other agency under same proprietor /common director(s) / common partner(s).
- ❖ I/ We confirm that if any of the above statement / information furnished by us in this tender is found to be false/ fake at any stage of tender evaluation or during execution of contract, BHEL will have the right to initiate appropriate action including legal proceeds / termination of contract, recovery of damages, penalties etc. as deemed fit.



Bharat Heavy Electricals Limited
(A Government of India Undertaking)
Boiler Auxiliaries Plant
Ranipet-632406

Ref No. 975522072E

BHEL RANIPET BANK DETAILS

SECTION- 3 BANK AND PAYMENT MANDATE (Enclose supporting for the detail provided below)	
PAYMENT MODE (NEFT / RTGS / ECS/ CHEQUE)	RTGS
NAME OF BENEFICIARY	BHEL/BAP/RANIPET
NAME OF BANK	STATE BANK OF INDIA
BANK BRANCH ADDRESS	STATE BANK OF INDIA BHEL PROJECT BRANCH MUKUNDARAYA PURAM BHEL TOWNSHIP RANIPET-632406
ACCOUNT TYPE (SAVINGS, CURRENT, CASH CREDIT, ETC)	CASH CREDIT (CC)
ACCOUNT NO	10664849171
MICR CODE (9 DIGIT MICR CODE AS APPEARING ON CHEQUE LEAF) (EXAMPLE 110240157)	632002003
IFSC CODE (11 DIGIT IFSC CODE OF THE BANK BRANCH) (EXAMPLE HDFC0001374)	SBIN0007013
DECLARATION I/WE, HEREBY DECLARE THAT THE PARTICULARS GIVEN ABOVE ARE CORRECT AND COMPLETE. IN CASE THE TRANSACTION IS DELAYED OR NOT EFFECTED AT ALL FOR REASONS OF INCOMPLETE OR INCORRECT INFORMATION AND FOR REASONS BEYOND THE CONTROL OF NBPL, I/WE WOULD NOT HOLD, NBPL RESPONSIBLE. I/WE DECLARE THAT, WHENEVER THERE IS A CHANGE IN THE ABOVE DETAILS, I/WE SHALL FURNISH THE FORM AFRESH.	
SIGNATURE : <i>N. Thalpathy</i> NAME : <i>17/12/2015</i> DESIGNATION : N. THALAPATHY DATE : Sr. Accounts Officer COMPANY SEAL : BHEL/BAP/ RANIPET	VERIFIED THE ABOVE DETAILS For STATE BANK OF INDIA <i>[Signature]</i> (SIGNATURE OF BANKER) BHEL Project, Muk. Puram SEAL OF THE BANKER L. KUMAR K-7346

(signature & seal of bidder)



Bharat Heavy Electricals Limited
 (A Government of India Undertaking)
 Boiler Auxiliaries Plant
 Ranipet-632406

Ref No. 975522072E



ACCEPTANCE FOR ELECTRONIC FUND TRANSFER / RTGS TRANSFER

01	NAME & ADDRESS OF THE SUPPLIER / VENDOR PHONE NO. WITH STD CODE	PAN NO. <input type="text"/>
02	VENDOR CODE (as in WORK ORDER)	<input type="text"/>
03	Details of Bank Account:	
A)	NAME & ADDRESS OF THE BANK (WITH PIN CODE)	<input type="text"/>
B)	BANK TELEPHONE NUMBER (WITH STD CODE)	<input type="text"/>
C)	BANK BRANCH CODE:	<input type="text"/>
D)	MICR CODE	<input type="text"/>
E)	ACCOUNT NUMBER	<input type="text"/>
F)	TYPE OF ACCOUNT	CURRENT / OD / CASH CREDIT
G)	VENDOR NAME AS PER BANK RECORDS	<input type="text"/>
H)	BANK BRANCH RTGS IFSC CODE	<input type="text"/>
I)	BANK BRANCH NEFT IFSC CODE	<input type="text"/>
J)	VENDOR'S EMAIL ID (give two ids)	<input type="text"/> <input type="text"/>
K)	NAME OF AUTHORISED SIGNATORY	<input type="text"/>

CERTIFICATE

I / We hereby agree to receive the payments due from BHARAT HEAVY ELECTRICALS LIMITED, RANIPET by the National Electronic Funds Transfer and/or RTGS Transfer mode by credit to my / our above mentioned Bank Account. I / We also agree that payments made to the above mentioned Account is a valid discharge of the liability of Bharat Heavy Electricals Limited, Ranipet. I / we also agree to bear the applicable Bank Charges for the above mode of transfer.

AUTHORISED SIGNATORY OF VENDOR WITH SEAL

Banker's Certification

We confirm that we are enabled for receiving RTGS and NEFT credits and we further confirm that the account number of _____

_____ (name of account holder), the signature of the authorized signatory and the MICR and IFSC codes of our Branch mentioned above are correct.

PLACE:

DATE:

 (Manager / Officer's
 Signature Under Bank stamp)
 Authorisation No. _____

Note: This EFT Form is to be submitted duly filled in manually in all fields and duly signed by Authorised Signatory and certified by Banker.

(signature & seal of bidder)



Bharat Heavy Electricals Limited
(A Government of India Undertaking)
Boiler Auxiliaries Plant
Ranipet-632406

Ref No. 975522072E

PRICE BID

Name of Work: Fabrication, Inspection, Painting of Steel boxes, and Crates inside BHEL, Ranipet premises with BHEL material.

Period of Work: One Year

S. NO	Description	Unit	Qty (a)	Total Amount in Rs (excluding GST)
			A	D
1	Fabrication, Inspection, Painting of Packing Steel boxes of various sizes inside BHEL, Ranipet premises with BHEL material as per scope of work.	No	1	To be quoted in BHEL GePNIC portal
Total Amount without GST (a)				To be quoted in BHEL GePNIC portal
GST@ _____% (b)				To be quoted in BHEL GePNIC portal
Total Amount including GST (c)=(a)+(b)				(c)=(a)+(b)

Note

1. The above rates are quoted after having fully read and understood the tender terms and conditions.
2. The evaluation currency for this tender shall be INR.
3. Applicable/Quoted GST amount will be extra & same will be taken into account while evaluating total cost to BHEL, for arriving at L1 bidder.
4. Any other entry elsewhere (individual item rate, if any) in the Price bid by the bidder shall be treated as Null and Void.
5. Payment shall be made for the actual quantities of work executed.

(signature & seal of bidder)



Bharat Heavy Electricals Limited
(A Government of India Undertaking)
Boiler Auxiliaries Plant
Ranipet-632406

Ref No. 975522072E

Tender Inviting Authority: BHEL BAP Ranipet									
Fabrication, Inspection, Painting of Packing Steel boxes of various sizes inside BHEL, Ranipet premises with BHEL material.									
Tender Notice No: 975522072E									
Name of the Bidder/ Bidding Firm / Company :									
PRICE SCHEDULE (This BOQ template must not be modified/replaced by the bidder and the same should be uploaded after filling the relevant columns, else the bidder is liable to be rejected for this tender. Bidders are allowed to enter the Bidder Name and Values only)									
NUMBER #	TEXT #	NUMBER #	TEXT #	TEXT #	NUMBER #	NUMBER #	NUMBER #	NUMBER #	TEXT #
Sl. No.	Item Description	Quantity	Units	Quoted Currency	Total Amount to be entered by the Bidder excluding GST in INR Rs. P	GST (IGST , SGST+CGST) IN %	TOTAL AMOUNT Without Taxes in Rs. P	TOTAL AMOUNT With Taxes in Rs. P	TOTAL AMOUNT In Words
1	2	4	5	12	13	16	53	54	55
1	Fabrication, Inspection, Painting of Steel boxes, and Crates inside BHEL, Ranipet premises with BHEL material. as per scope of work.	1	No	INR	To be Quoted in e-Procurement portal	To be Quoted in e-Procurement portal	0.00	0.00	INR Zero Only
Total in Figures							0.00	0.00	INR Zero Only
Quoted Rate in Words		INR Zero Only							

(signature & seal of bidder)



Annexure-I

Drawings

Page No	Description	Assembly Drawing no.
56	Type I Box	2-79-000-01740 REV07
57	Type I Box-SH	2-79-000-07777 REV00
58	Type II Box	2-79-000-01714 REV06
59	Type II B Box	2-79-000-01715 REV04
60	Type III Box	2-79-000-01713 REV07
61	Type IV Box	2-79-000-01741 REV06
62	Type V Box	2-79-000-01742 REV05

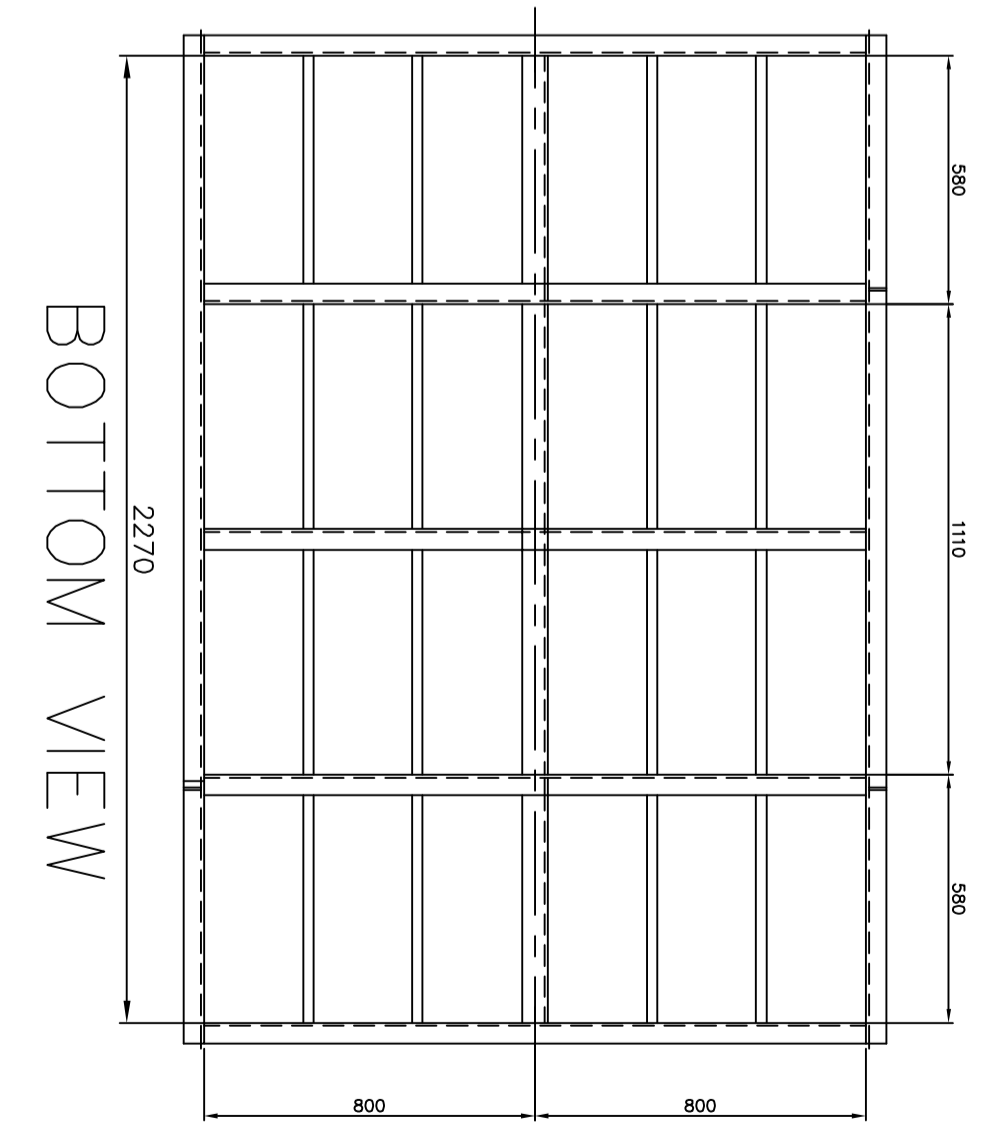
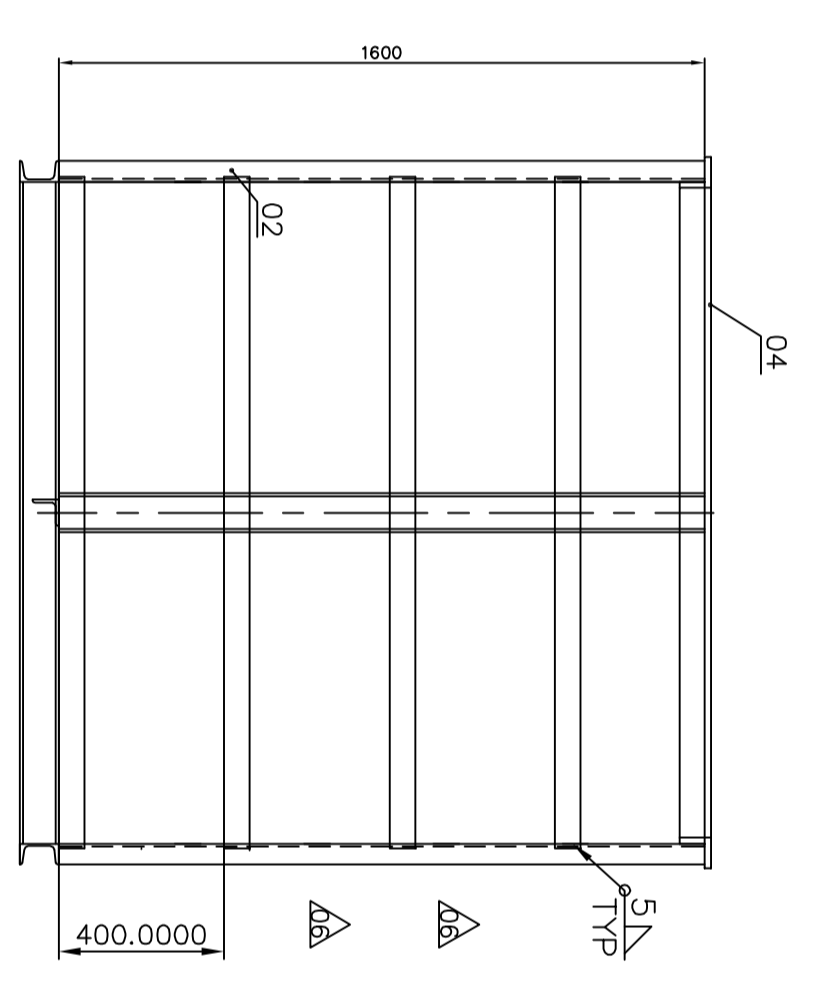
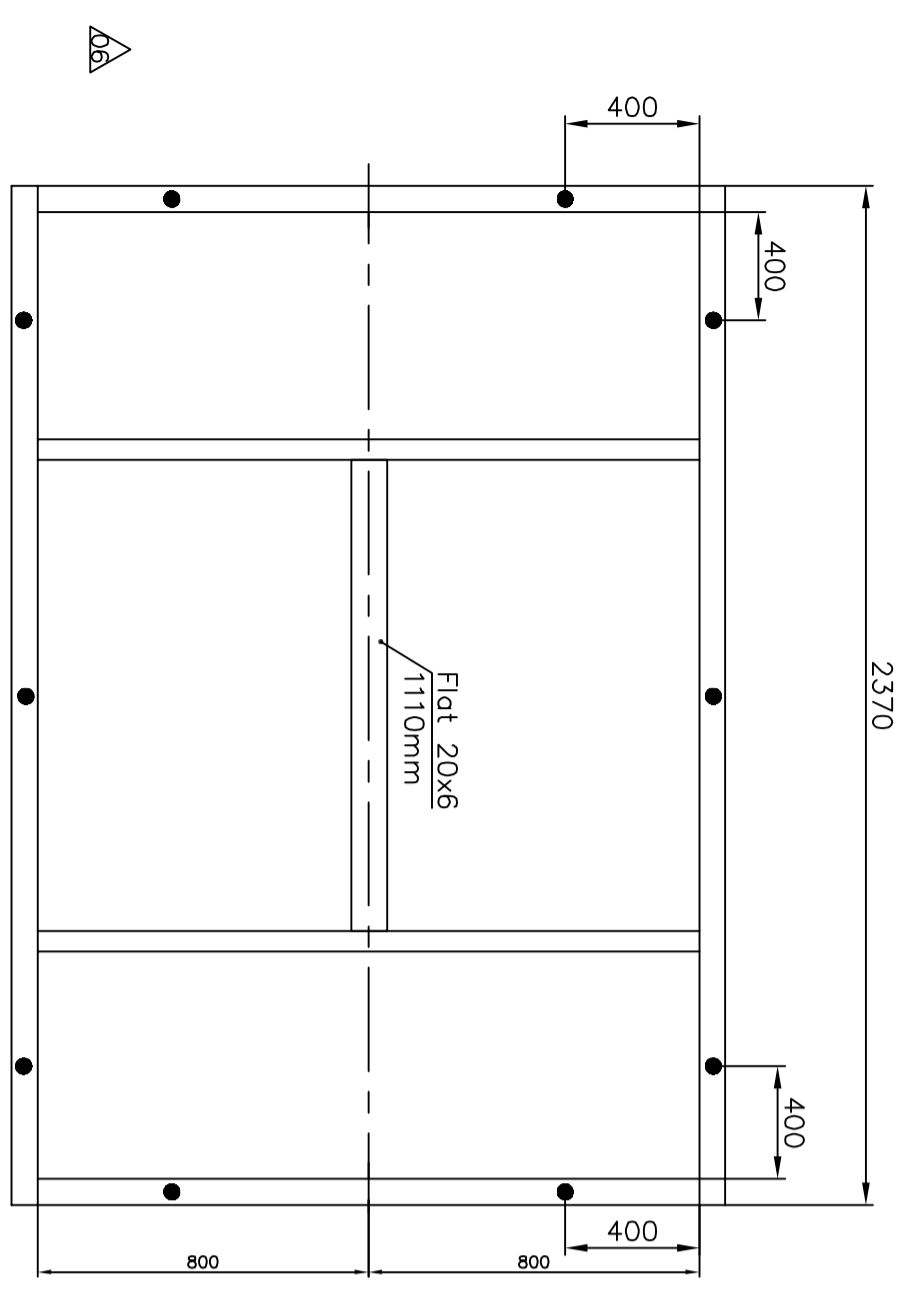

TOP VIEW

BOTTOM VIEW

Flats to be bend at the ends and welded.

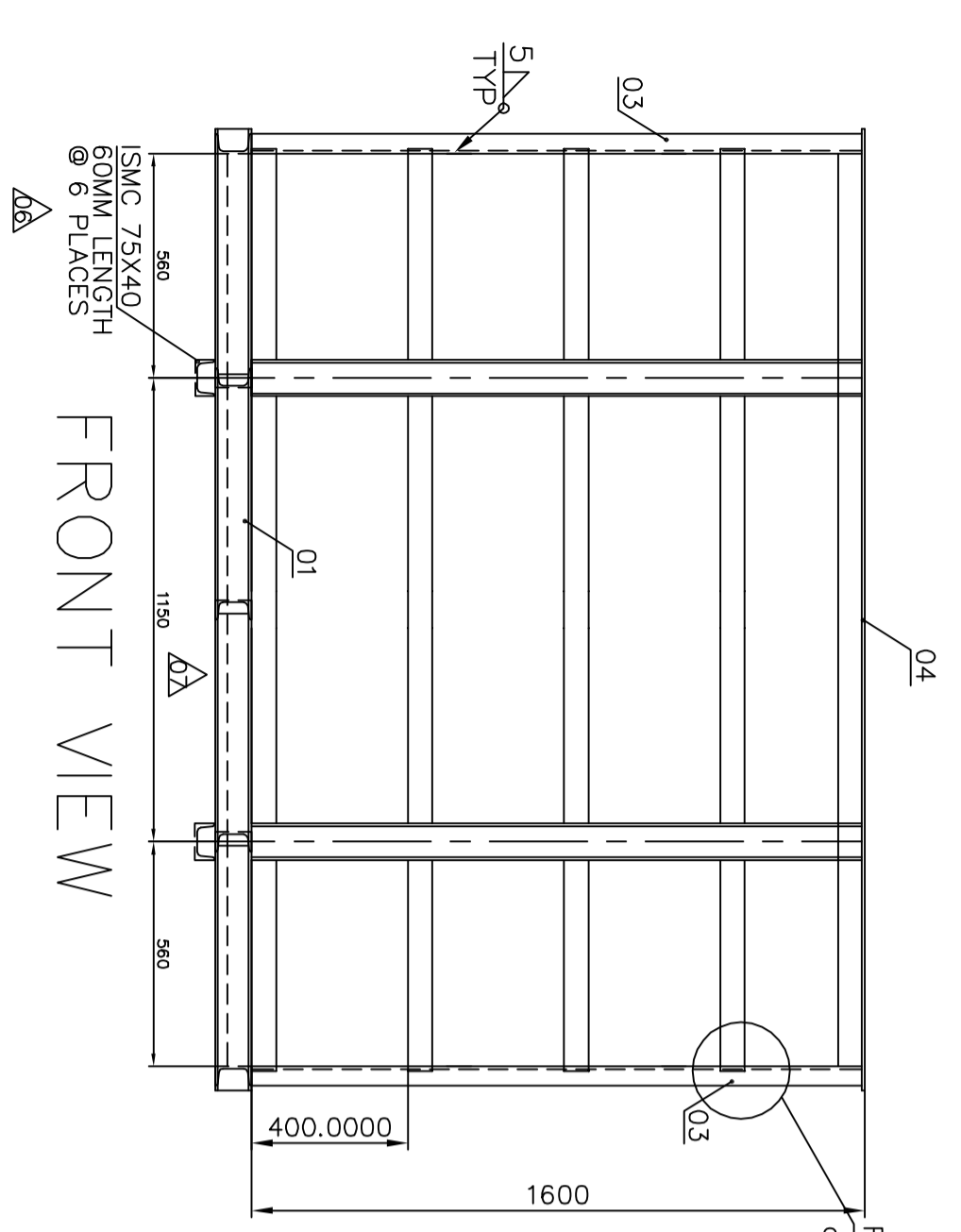

FRONT VIEW

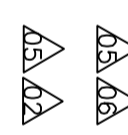

- NOTES:
- ALL BOX OPENING SHALL BE CLOSED USING ITEM-04.
 - TOP FRAME SHALL BE TACK WELD AT VENDOR WORKS TO ENABLE SHIPPING TO OPEN AND USE.
 - ONE COAT OF RED OXIDE PAINT IS TO BE APPLIED, TO AVOID RUSTING.
 - WELD 2A WHEREVER NOT SHOWN.
 - ITEMS USED ISMC75 SHALL BE SUBSTITUTED WITH MATERIALS ON HIGHER SIDE ONLY.
 - LOAD CARRYING CAPACITY: 4500Kgs.

VARIANT NO	ITEM NO	DESCRIPTION	DRAWING NO.	ITEM NO. VAR NO.	MATL. CODE	MATL. SPEC	A	B	C	D	UNIT WT.	QUANTITY
	06	Screw & Nut M10X35			4125510035						0.040	
	05	SH 0.63mm / Corr. Sheet / CE RANDOM SHEET			IS:1363 15-911-7150100						4.946 18.968	
	04	TOP FRAME			3-79-000-01449						57.290	
	03	SIDE FRAME			3-79-000-01448						32.154	
	02	FRONT FRAME			3-79-000-01447						31.703	
	01	BOTTOM FRAME			3-79-000-01446						114.032	

REV	DATE	ALTERED	BY	REASON	REV	DATE	ALTERED	BY	REASON
07	7-7-2015	CHECKED	S.MANIVANNAN	DRAWING CORRECTED BASED ON SHIPPING FEEDBACK WEIGHT ALSO CHANGED.	02	18.02.11	CHECKED		
06	02.09.14	CHECKED	C.Ganesh	DRAWING CORRECTED BASED ON SHIPPING FEEDBACK	01	20.05.09	CHECKED		
05	07.03.11	CHECKED	C.Ganesh	Lifting hook arrangement modified based on comml feedback.	03	07.03.11	CHECKED		
04	31.12.12	CHECKED	C.Ganesh	AS 0.63mm THICK 2mm CHANGED ITEM 01 TO 04 WT. ALTERED. TOTAL WEIGHT CORRECTED.	04	31.12.12	CHECKED		
05	02.08.13	CHECKED	C.Ganesh	ZONEDRAWING CORRECTED BASED ON OS FEEDBACK	05	02.08.13	CHECKED		

CAUTION: The information on this document is the property of BHARAT HEAVY ELECTRICALS LTD. It must not be used directly or indirectly in any way detrimental to the interest of the company.

BHARAT HEAVY ELECTRICALS LTD.
UNIT: BOILER AUXILIARIES PLANT,
RANIPET - 632 406.

TYPE OF PRODUCT
OR NAME OF CUSTOMER/PROJECT
LOAD CARRYING CAPACITY=4500KGS.

DEPT ACOSS UNTL.DIM
GRADE OF PR:QA:500
SCALE N.T.S
WEIGHT (KG) 393,252
DRN A.PARASU
CHD C.GANESH
APPD C.GANESH
REF. TO ASSY/OLD DRG. 1-SH-BAP-025
DATE 14.01.2009
NO.OF 05

TITLE
TYPE-I STEEL BOX
PACKING ASSEMBLY

CARD CODE U 01
DRAWING NO. 2-79-000-01740
REV 07

REV	DATE	ALTERED	BY	REASON
05	02.08.13	CHECKED	C.Ganesh	ZONEDRAWING CORRECTED BASED ON OS FEEDBACK
04	31.12.12	CHECKED	C.Ganesh	AS 0.63mm THICK 2mm CHANGED ITEM 01 TO 04 WT. ALTERED. TOTAL WEIGHT CORRECTED.
03	07.03.11	CHECKED	C.Ganesh	Lifting hook arrangement modified based on comml feedback.
02	18.02.11	CHECKED		BOM -ITEM No.05 QTY ALTERED.
01	20.05.09	CHECKED		ITEM No.06&07 ADDED IN BOM. TOTAL WT. ALTERED.

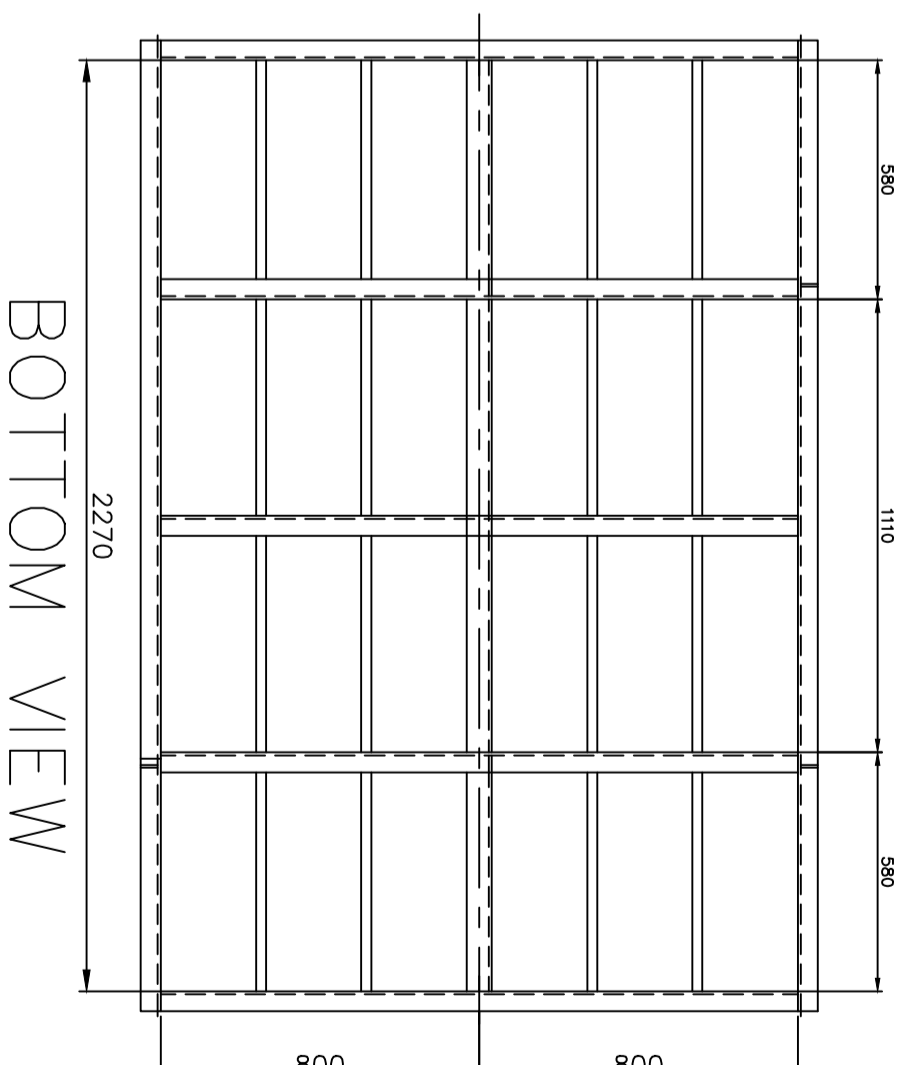
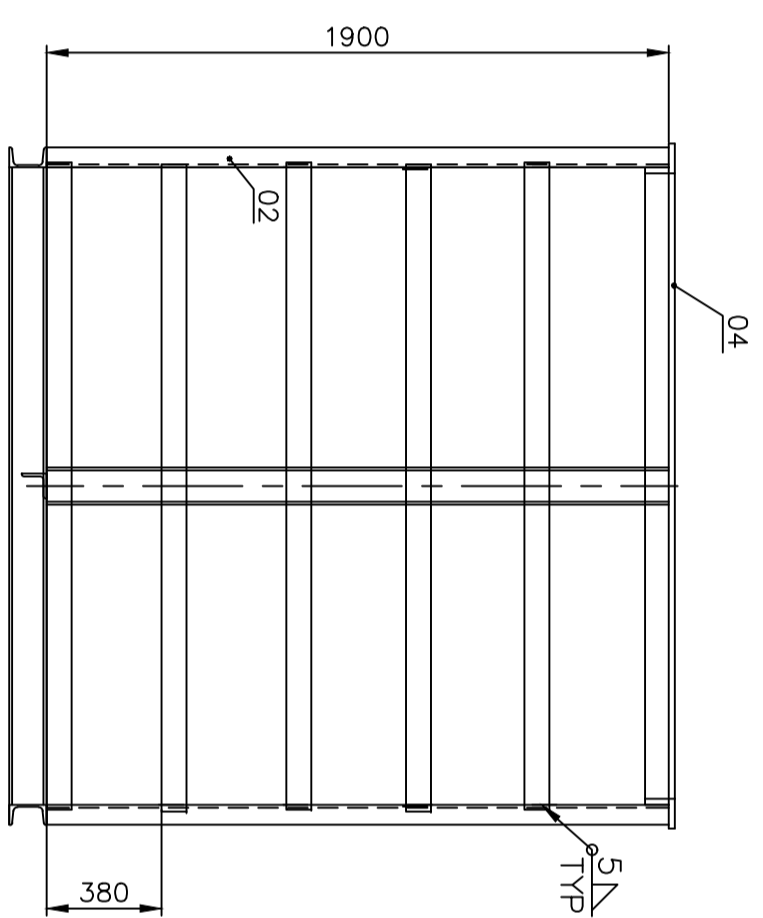
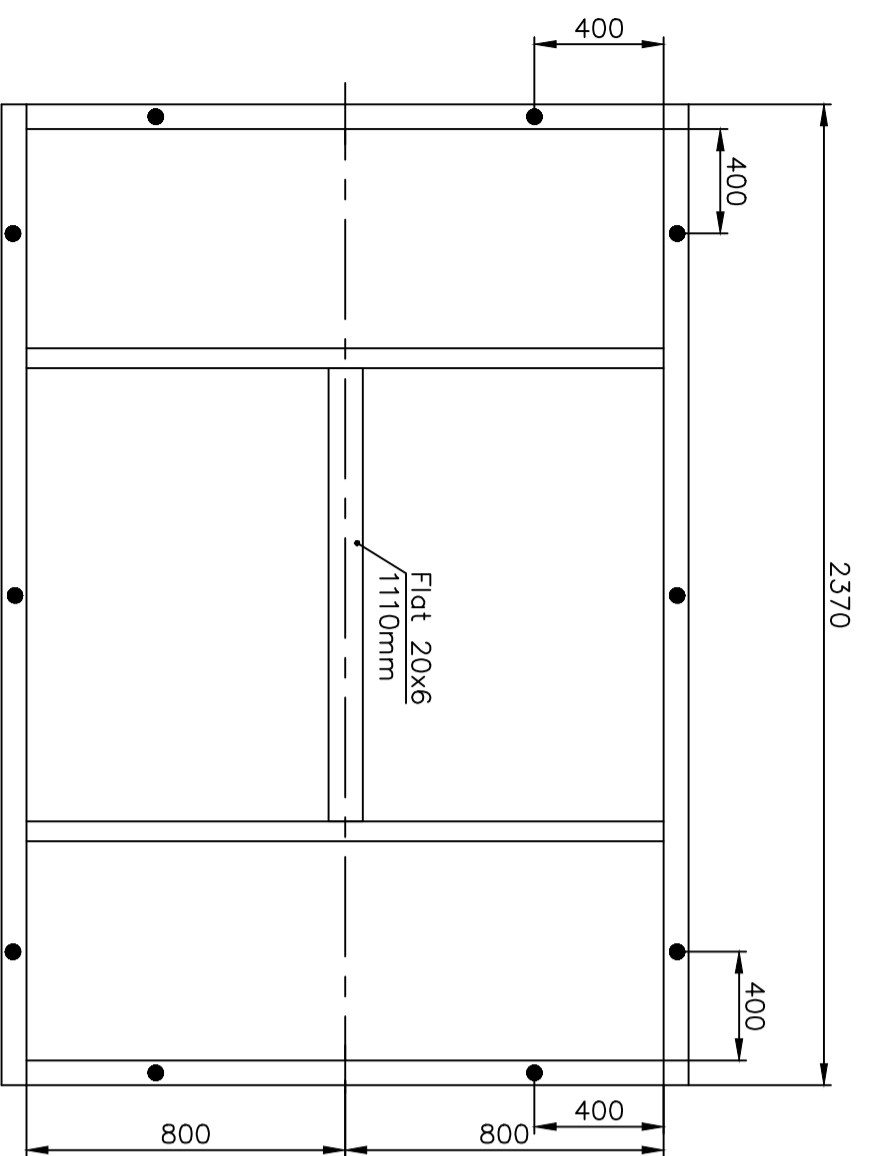

ALL DIMENSIONS ARE IN MILLIMETRES

TOP VIEW

SIDE VIEW

BOTTOM VIEW

Flats to be bend at the ends and welded.

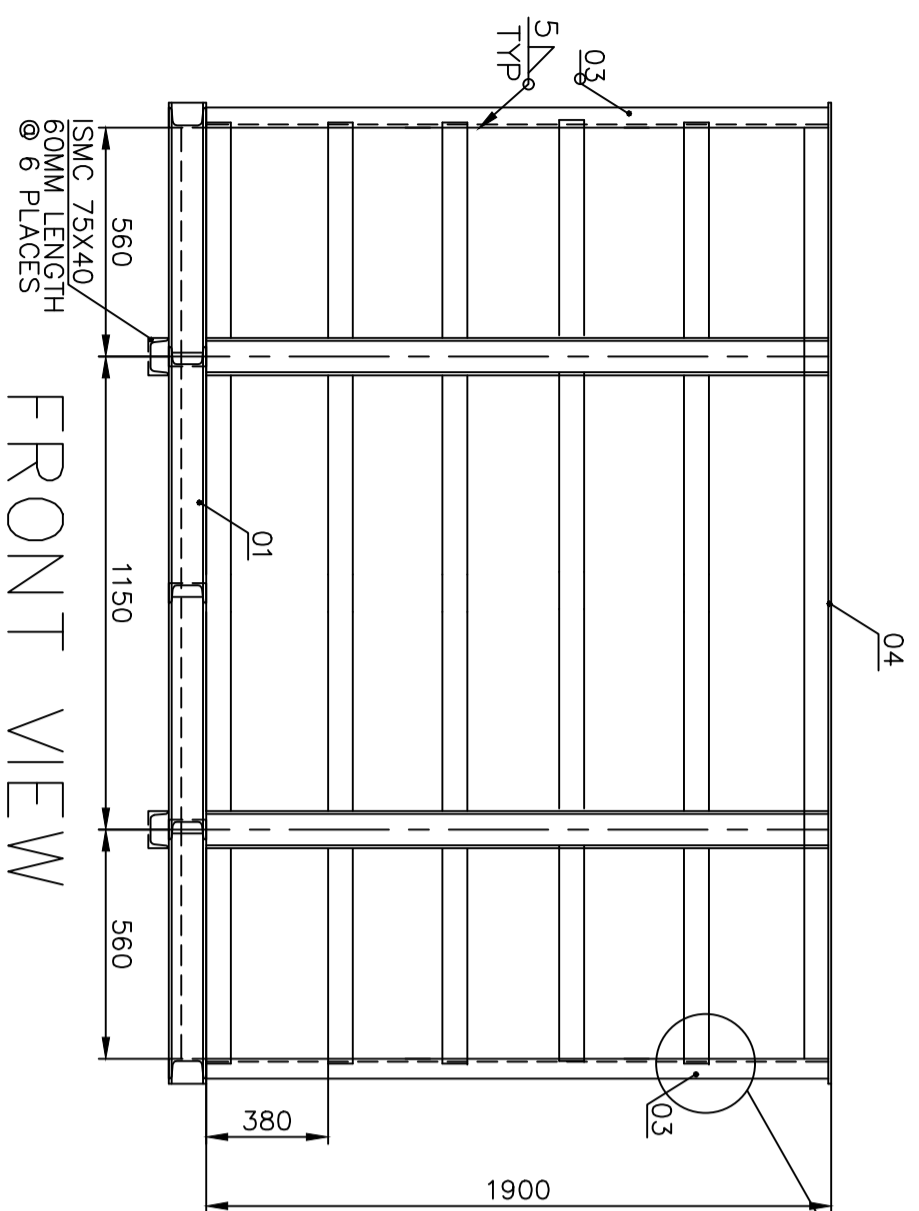

FRONT VIEW

NOTES:

01. ALL BOX OPENING SHALL BE CLOSED USING ITEM-04.
02. TOP FRAME SHALL BE TACK WELD AT VENDOR WORKS TO ENABLE SHIPPING TO OPEN AND USE.
03. ONE COAT OF RED OXIDE PAINT IS TO BE APPLIED, TO AVOID RUSTING.
04. WELD 2A WHEREVER NOT SHOWN.
05. ITEMS USED ISMC75 SHALL BE SUBSTITUED WITH MATERIALS ON HIGHER SIDE ONLY.
06. LOAD CARRYING CAPACITY: 4500Kgs.
07. THIS DRAWING IS PREPARED BASED ON SHIPPING FEEDBACK TO INCREASE EXISTING STEEL BOX HEIGHT FROM 1600MM TO 1900MM.

VARIANT NO	ITEM NO	DESCRIPTION	IS	DRAWING NO.	ITEM NO	MATL. CODE	UNIT WT.	QUANTITY	ZONE
	06	Screw & Nut M10X35				4125510035	0.040		
	05	SH 0.63mm/Corr. Sheet/CE RANDOM SHEET				IS: 1363 15-911-7150100 IS: 513 DD	10 4.946 18.968		
	04	TOP FRAME		3-79-000-01449			57.290	1	
	03	SIDE FRAME		3-79-000-03923			38.579	2	
	02	FRONT FRAME		3-79-000-03922			38.20	2	
	01	BOTTOM FRAME		3-79-000-01446			114.032	1	

TYPE OF PRODUCT
OR NAME OF
CUSTOMER/PROJECT
LOAD CARRYING CAPACITY=4500Kgs.

BHARAT HEAVY ELECTRICALS LTD.
UNIT: BOILER AUXILIARIES PLANT.
RANIPET - 632 406.

REV	DATE	ALTERED
		CHECKED
		ZONE

DEPT	GRADE OF	SCALE	WEIGHT (KG)	APPD	NAME	SIGN	DATE	NO. OF
AGCS	UNIT/DIM	N.T.S	419.096	C.HD	K.RAJI		12.04.19	VAR.
CODE	PR.OA:500			C.GANESH				
TITLE	TYPE-1900MM LENGTH			CARD	DRAWING NO.			REV
	STEEL BOX PACKING ASSEMBLY			U 01	2-79-000-07777			00

CAUTION: The information on this document is the property of BHARAT HEAVY ELECTRICALS LTD. It must not be used directly or indirectly in any way detrimental to the interest of the company.

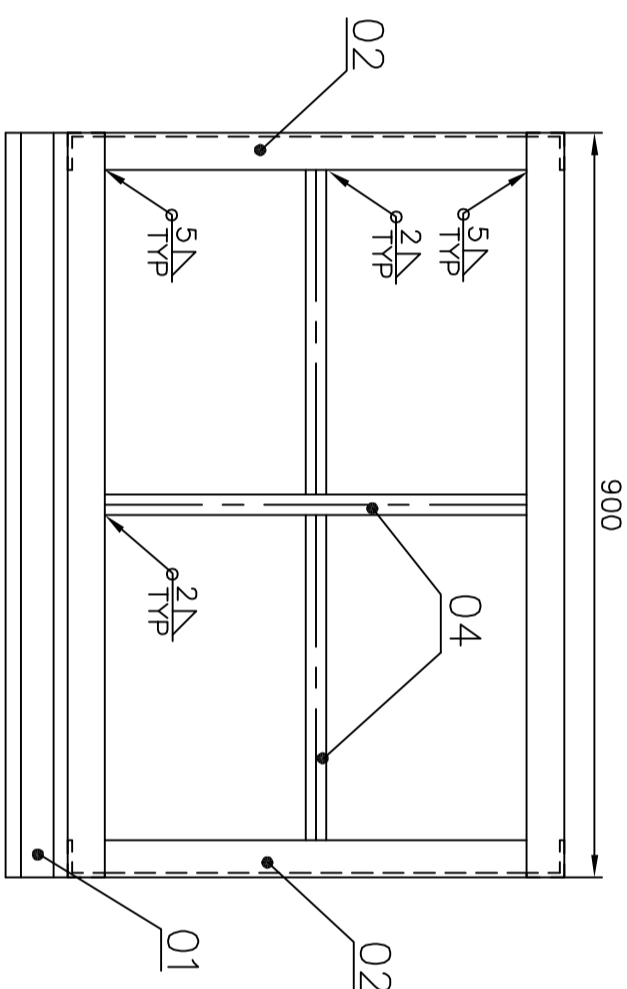
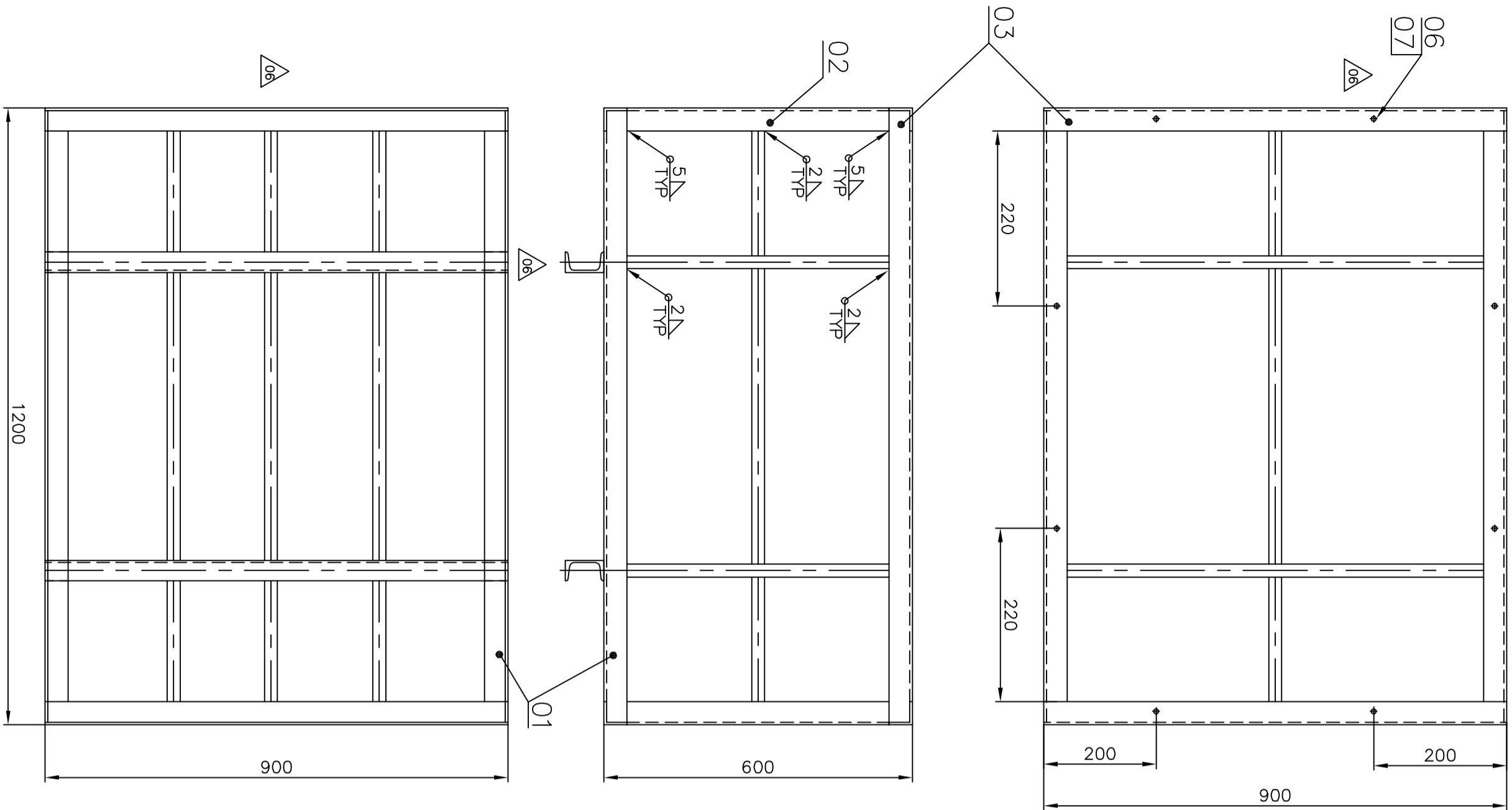

REV	DATE	ALTERED	BY	CHECKED	ZONE
06	08.06.15	CHECKED	Adarsh	C.Ganesh	
06	08.06.15	CHECKED	C.Ganesh		
ZONE Additional one flat added at zone					
E2, length of channel shortened to 900mm and qty changed for Item 05 based on Shipping feedback.					
Weight changed for Packing box.					
06	08.06.15	CHECKED	Adarsh	C.Ganesh	
03	05.09.12	CHECKED			
ITEM No.07 DELETED IN BOM. TOTAL WT. ALTERED.					
04	15.02.14	CHECKED			
ITEM No.03 Top Frame wt altered					
02	25.03.11	CHECKED			
ITEM No.04 DESCRIPTION & TOTAL WT. ALTERED.					
05	22.02.14	CHECKED	C.Ganesh		
Wt corrected for SI 01 & 02					

NOTES:

01. ALL BOX OPENING SHALL BE CLOSED USING ITEM-04 / 0.63 SHEETS.
02. SHEET 0.63 SHALL ALSO CAN BE FIXED USING SELF DRILL GUN AND SELF TAPPING SCREWS. TOOL REQUIRED IS SELF DRILL GUN & SCREWS ONLY.
03. TOP FRAME SHALL BE TACK WELD AT VENDOR WORKS TO ENABLE SHIPPING TO OPEN AND USE.
04. ONE COAT OF RED OXIDE PAINT IS TO BE APPLIED, TO AVOID RUSTING.
05. WELD 2A WHEREVER NOT SHOWN.
06. ITEMS USED A45x45x5, ISMC75 AND SH 2.5 SHALL BE SUBSTITUED WITH MATERIALS ON HIGHER SIDE ONLY.
07. LOAD CARRYING CAPACITY: 2000Kgs.
08. CHANNEL 75X40 SHORTENED TO 900MM & ONE ADDITIONAL FLAT ADDED.

VARIANT NO	ITEM NO	DESCRIPTION	QTY	DRAWING NO.	ITEM VAR NO	MATL CODE	MATL SEC	A	B	C	D	UNIT WT.	QTY	ZONE
	07	HEX NUT M16				4130400010		NO				0.0031	8	
	06	SCRU & NUT M10X35				412551003500		NO				0.040	8	
	05	SH 0.63				IS.1363		NO				4.945	2	
	04	FLAT 20X6				IS.513 DD		NO				0.942	2	
	03	TOP FRAME				15-008-207		NO				2.65	1	
	02	FRONT FRAME				IS.2062		NO				20.874	1	
	01	BOTTOM FRAME						NO				5.475	1	
								NO				30.268	2	

TYPE OF PRODUCT
OR NAME OF
CUSTOMER/PROJECT

LOAD CARRYING CAPACITY 2000KGS.

BHARAT HEAVY ELECTRICALS LTD.,
UNIT. BOILER AUXILIARIES PLANT,
RAIPET - 632 406.

DEPT: A.P.PARASU
ACCS: C.GANESH
PR: 04: 500
SCALE: N.T.S
WEIGHT (KG): 91.523
CARD CODE: U 01
DRAWING NO.: 2-79-000-01714

CAUTION: The information on this document is the property of BHARAT HEAVY ELECTRICALS LTD. It must not be used directly or indirectly in any way detrimental to the interest of the company.

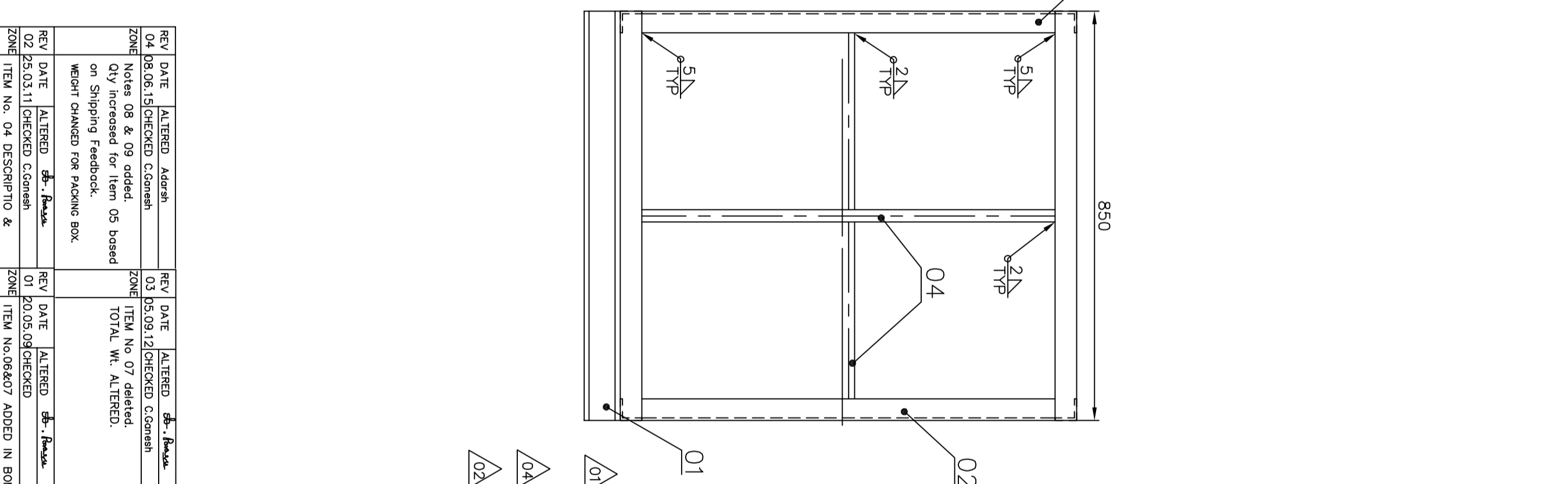
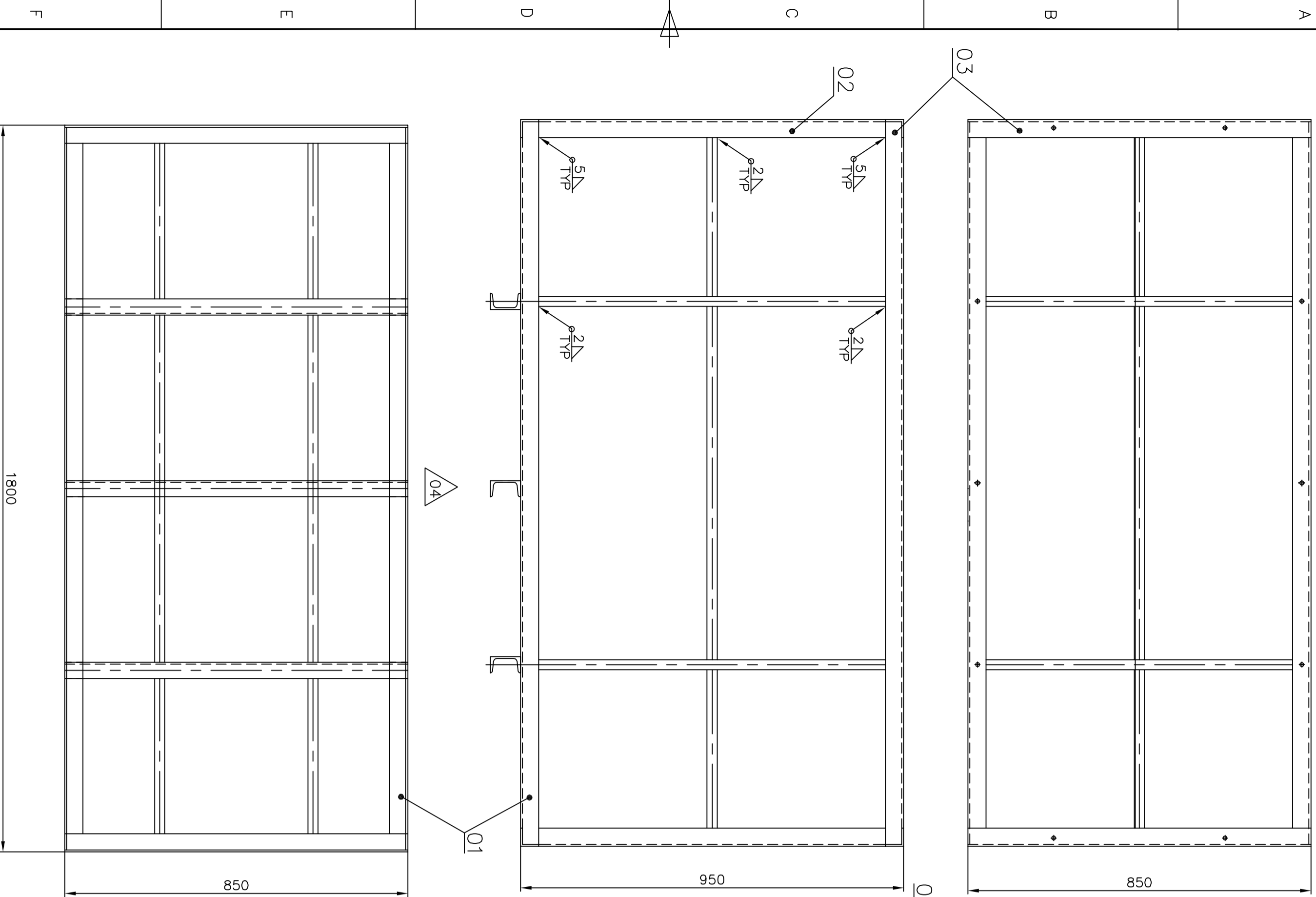

- NOTES:**
01. ALL BOX OPENING SHALL BE CLOSED USING ITEM-04 / 0.63 SHEETS.
 02. SHEET 0.63 SHALL ALSO CAN BE FIXED USING SELF DRILL GUN AND SELF TAPPING SCREWS. TOOL REQUIRED IS SELF DRILL GUN & SCREWS ONLY.
 03. TOP FRAME SHALL BE TACK WELD AT VENDOR WORKS TO ENABLE SHIPPING TO OPEN AND USE.
 04. ONE COAT OF RED OXIDE PAINT IS TO BE APPLIED, TO AVOID RUSTING.
 05. WELD 2A WHEREVER NOT SHOWN.
 06. ITEMS USED A45x45x5, ISMC75 AND SH 2.5 SHALL BE SUBSTITUED WITH MATERIALS ON HIGHER SIDE ONLY.
 07. LOAD CARRYING CAPACITY: 2500Kgs.
 08. ONE ADDITIONAL CHANNEL ISMC 75X40 ADDED AT ZONE E2.
 09. LENGTH OF THE CHANNEL SHORTENED TO 850MM AT ZONE E2..

VARIANT NO	ITEM NO	DESCRIPTION	DRAWING NO.	ITEM NO. VAR NO	MATL. CODE	MATL. SPEC	A	B	C	D	UNIT WT.	QUANTITY	REV
07	HEX-NUT M10	03			413040010						0.003	40	
06	SCRU & NUT M10X35				412551003500						0.040	10	
05	SH 0.63				15-811-715						4.945	2	
04	FLAT 20X6				15-513 DD						9.310	1	
03	TOP FRAME				15-008-207						0.942	3.24	
02	FRONT FRAME										26.12	1	
01	BOTTOM FRAME										9.079	2	
											39.449	1	

REV	DATE	ALTERED	ADDSH	REV	DATE	ALTERED	ADDSH
04	08.06.15	CHECKED	C.Ganesh	03	05.09.12	CHECKED	C.Ganesh
02	25.03.11	CHECKED	C.Ganesh	01	20.05.09	CHECKED	

Zone Notes 08 & 09 added Qty increased for Item 05 based on Shipping Feedback.
Weight changed for Packing Box.

CAUTION: The information on this document is the property of BHARAT HEAVY ELECTRICALS LTD. It must not be used directly or indirectly in any way detrimental to the interest of the company.

TYPE OF PRODUCT OR NAME OF CUSTOMER/PROJECT
LOAD CARRYING CAPACITY 2500KGS.

BHARAT HEAVY ELECTRICALS LTD.,
UNIT: BOILER AUXILIARIES PLANT,
RAIPET - 632 406.

DEPT: ACOCS
GRADE OF UNITS: DIM
PR. QA: 500
SCALE: N.T.S
WEIGHT (KG): 133,218

DRN: A.PARASU
SIGN: C.GANESH
DATE: 27.12.2008

CHD: C.GANESH
REF. TO ASSY/OLD DRG.: 2-SH-BAP-026

APPD: C.GANESH
NO. OF REVS: 05

TITLE: TYPE-IIB STEEL BOX PACKING ASSEMBLY

CARD CODE: U 01

DRAWING NO.: 2-79-000-01715

REV: 04

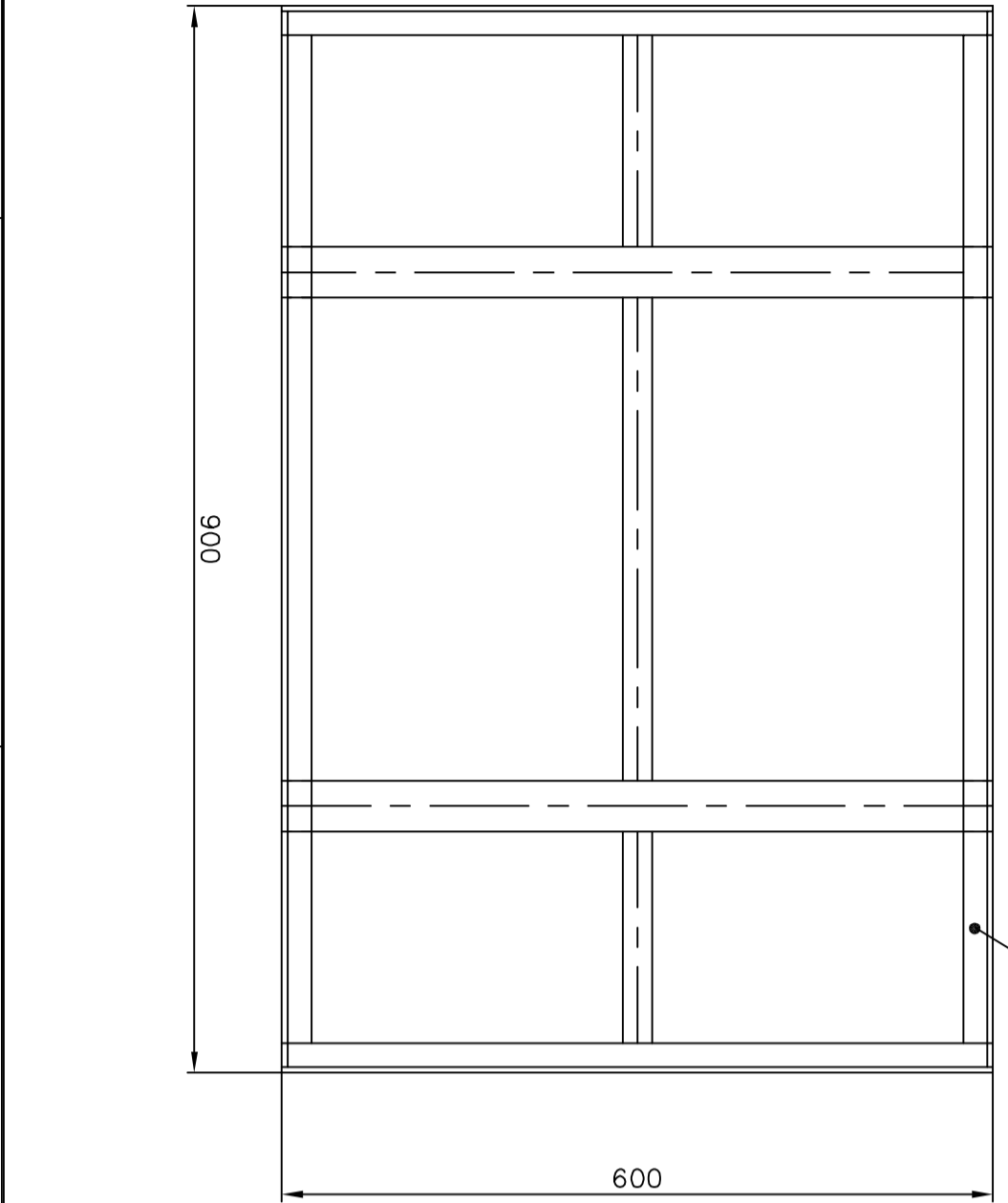
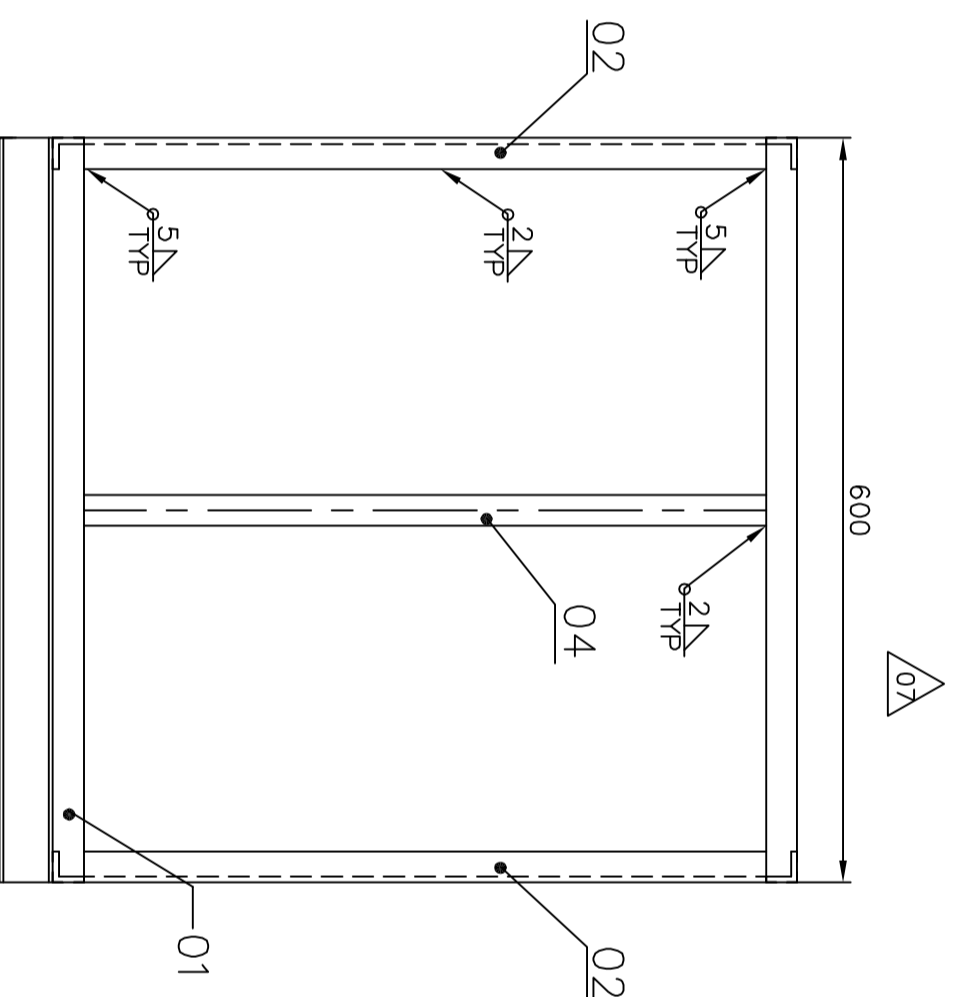
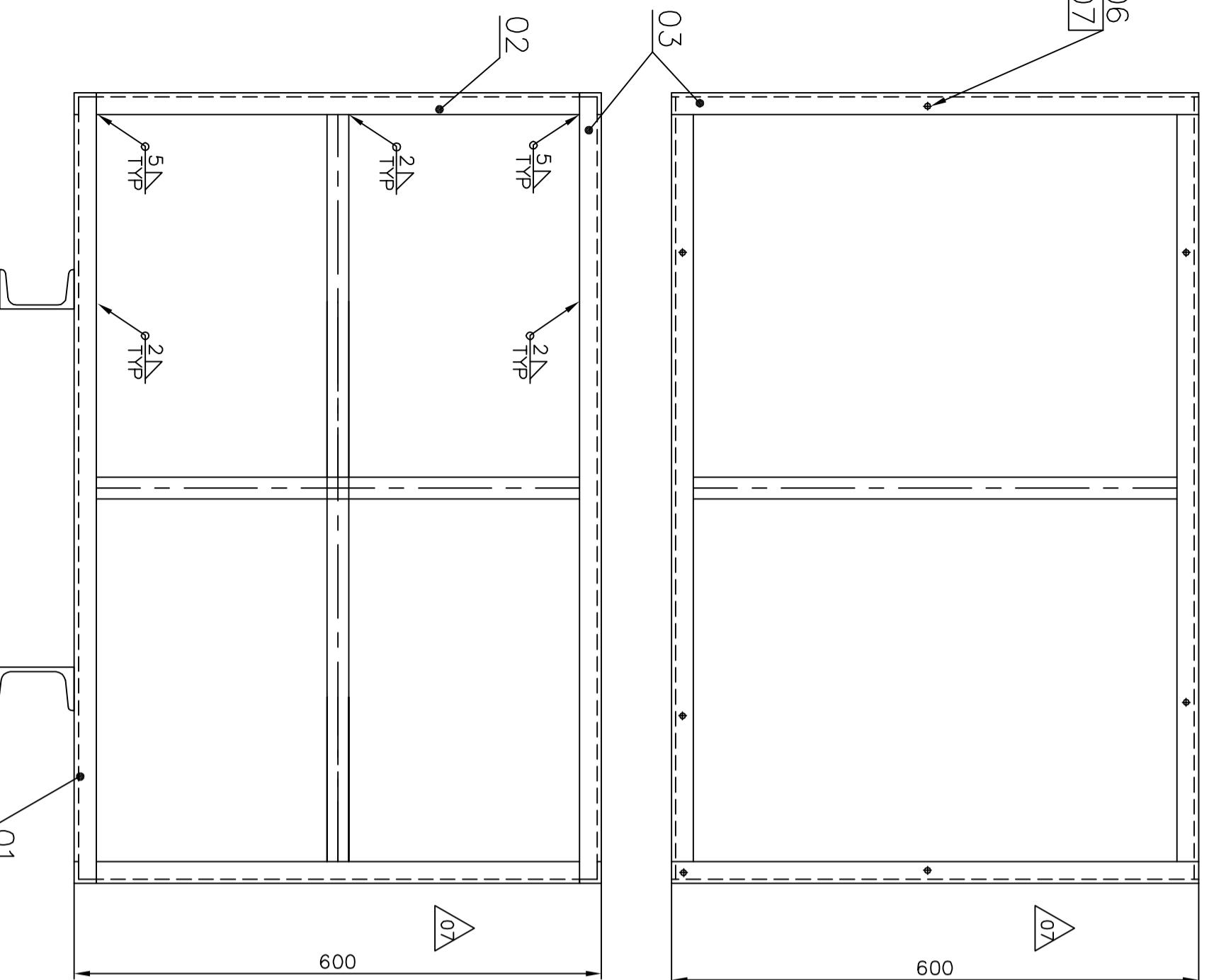

REV	DATE	ALTERED	By: <i>Pankaj</i>		
06	23.06.14	CHECKED			
ZONE weight corrected for item no 1&3					
REV	DATE	ALTERED	By: <i>Pankaj</i>		
05	17.12.13	CHECKED			
ZONE REVISED BASED ON FEEDBACK FROM OS					
REV	DATE	ALTERED	By: <i>Pankaj</i>		
04	17.12.13	CHECKED			
ZONE ITEM No.01,02&03 Wt. CORRECTED					
REV	DATE	ALTERED	By: <i>Pankaj</i>		
03	05.09.12	CHECKED			
ZONE ITEM No.07 DELETED IN BOM. TOTAL Wt. ALTERED.					
REV	DATE	ALTERED	By: <i>Pankaj</i>		
02	25.03.11	CHECKED			
ZONE ITEM No.04 DESCRIPTION ALT. TOTAL Wt. ALTERED.					
REV	DATE	ALTERED	By: <i>Pankaj</i>		
01	20.05.09	CHECKED			
ZONE ITEM No.06&07 ADDED IN BOM. TOTAL Wt. ALTERED.					

NOTES:

01. ALL BOX OPENING SHALL BE CLOSED USING ITEM-04 / 0.63 SHEETS.
02. SHEET 0.63 SHALL ALSO CAN BE FIXED USING SELF DRILL GUN AND SELF TAPPING SCREWS. TOOL REQUIRED IS SELF DRILL GUN & SCREWS ONLY.
03. TOP FRAME SHALL BE TACK WELD AT VENDOR WORKS TO ENABLE SHIPPING TO OPEN AND USE.
04. ONE COAT OF RED OXIDE PAINT IS TO BE APPLIED, TO AVOID RUSTING.
05. WELD 2A WHEREVER NOT SHOWN.
06. ITEMS USED A25x25x2.5 COMMERCIAL QUALITY CAN BE USED. FOR MATERIAL SUBSTITUTION USE MATERIALS ON HIGHER SIDE ONLY.
07. ITEM USED TUBE DIA 42.9X3.25 CAN BE SUBSTITUTED ON HIGHER SIDE ONLY.
08. LOAD CARRYING CAPACITY:1000Kgs.
09. FLATS REMOVED FORM FRONT, TOP AND SIDE FRAME BASED ON SHIPPING FEEDBACK.
10. LENGTH OF CHANNEL SHORTENED TO 600 MM AT ZONE E2.
11. QUANTITY FOR ITEM NO 05 INCREASED BASED ON SHIPPING FEEDBACK.

REV	DATE	ALTERED	By: <i>Pankaj</i>		
02	25.03.11	CHECKED			
ZONE ITEM No.04 DESCRIPTION ALT. TOTAL Wt. ALTERED.					
REV	DATE	ALTERED	By: <i>Pankaj</i>		
01	20.05.09	CHECKED			
ZONE ITEM No.06&07 ADDED IN BOM. TOTAL Wt. ALTERED.					

REV	DATE	ALTERED	By: <i>Pankaj</i>		
06	23.06.14	CHECKED			
ZONE weight corrected for item no 1&3					
REV	DATE	ALTERED	By: <i>Pankaj</i>		
05	17.12.13	CHECKED			
ZONE REVISED BASED ON FEEDBACK FROM OS					
REV	DATE	ALTERED	By: <i>Pankaj</i>		
04	17.12.13	CHECKED			
ZONE ITEM No.01,02&03 Wt. CORRECTED					
REV	DATE	ALTERED	By: <i>Pankaj</i>		
03	05.09.12	CHECKED			
ZONE ITEM No.07 DELETED IN BOM. TOTAL Wt. ALTERED.					
REV	DATE	ALTERED	By: <i>Pankaj</i>		
02	25.03.11	CHECKED			
ZONE ITEM No.04 DESCRIPTION ALT. TOTAL Wt. ALTERED.					
REV	DATE	ALTERED	By: <i>Pankaj</i>		
01	20.05.09	CHECKED			
ZONE ITEM No.06&07 ADDED IN BOM. TOTAL Wt. ALTERED.					

REV	DATE	ALTERED	By: <i>Pankaj</i>		
02	25.03.11	CHECKED			
ZONE ITEM No.04 DESCRIPTION ALT. TOTAL Wt. ALTERED.					
REV	DATE	ALTERED	By: <i>Pankaj</i>		
01	20.05.09	CHECKED			
ZONE ITEM No.06&07 ADDED IN BOM. TOTAL Wt. ALTERED.					

CAUTION: The information on this document is the property of BHARAT HEAVY ELECTRICALS LTD. It must not be used directly or indirectly in any way detrimental to the interest of the company.

TYPE OF PRODUCT
 OR NAME OF
 CUSTOMER/PROJECT
 LOAD CARRYING CAPACITY 1000KGS.

BHARAT HEAVY ELECTRICALS LTD.
 UNIT: BOILER AUXILIARIES PLANT,
 RAIPUR - 832 406.

DEPT: APCS
 GRADE OF UNITS: 500
 SCALE: N.T.S
 WEIGHT (KG): 41.946
 CARD CODE: U 01
 DRAWING NO.: 2-79-000-01713
 REV: 07

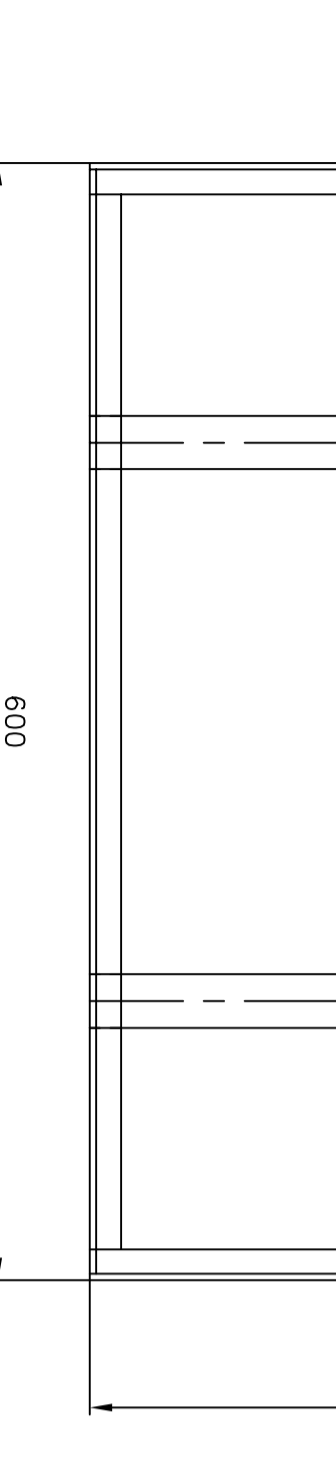
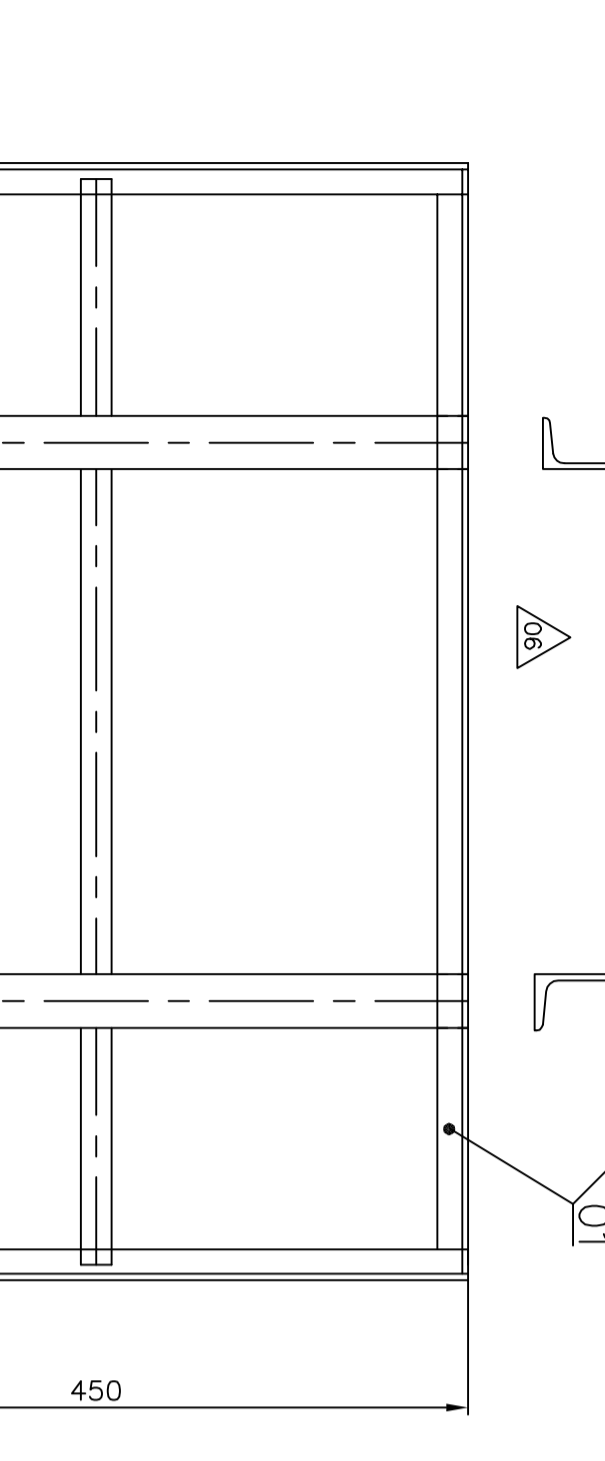
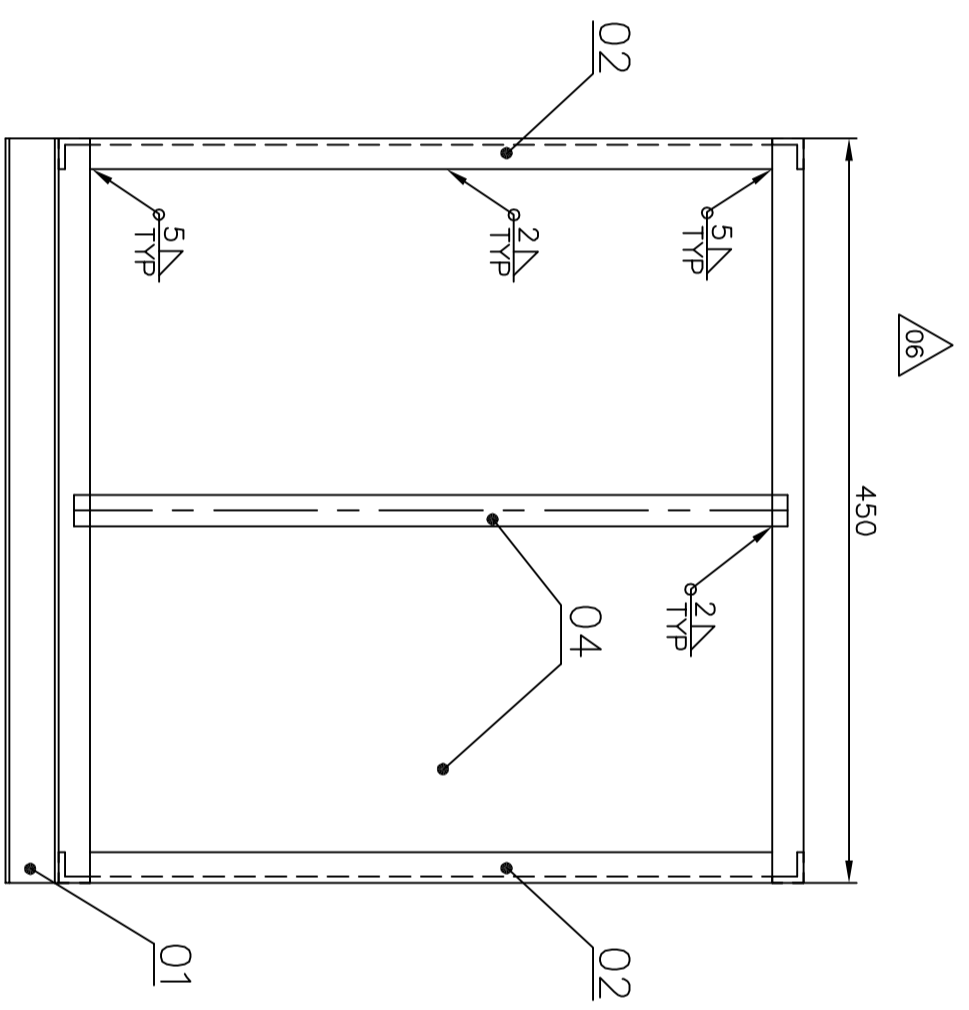
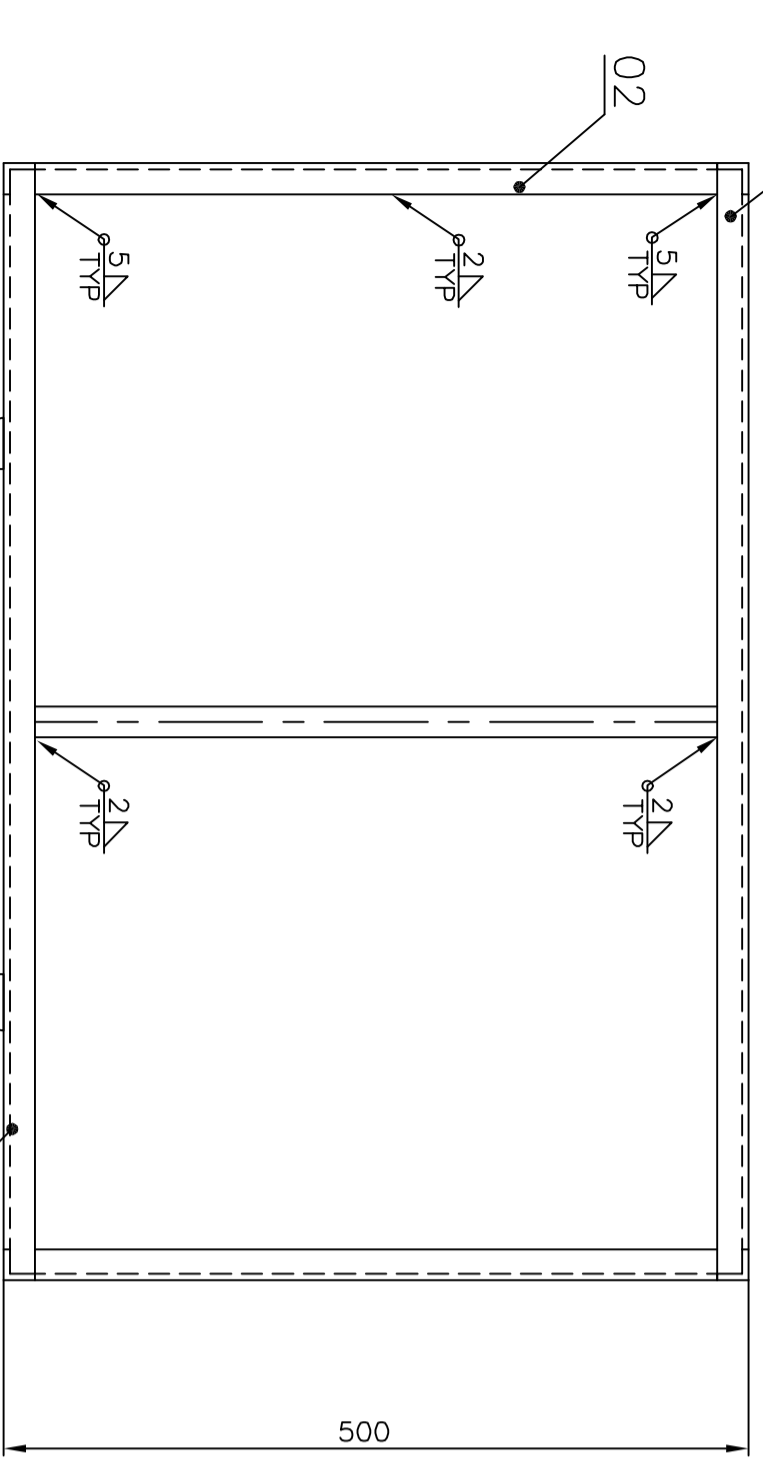
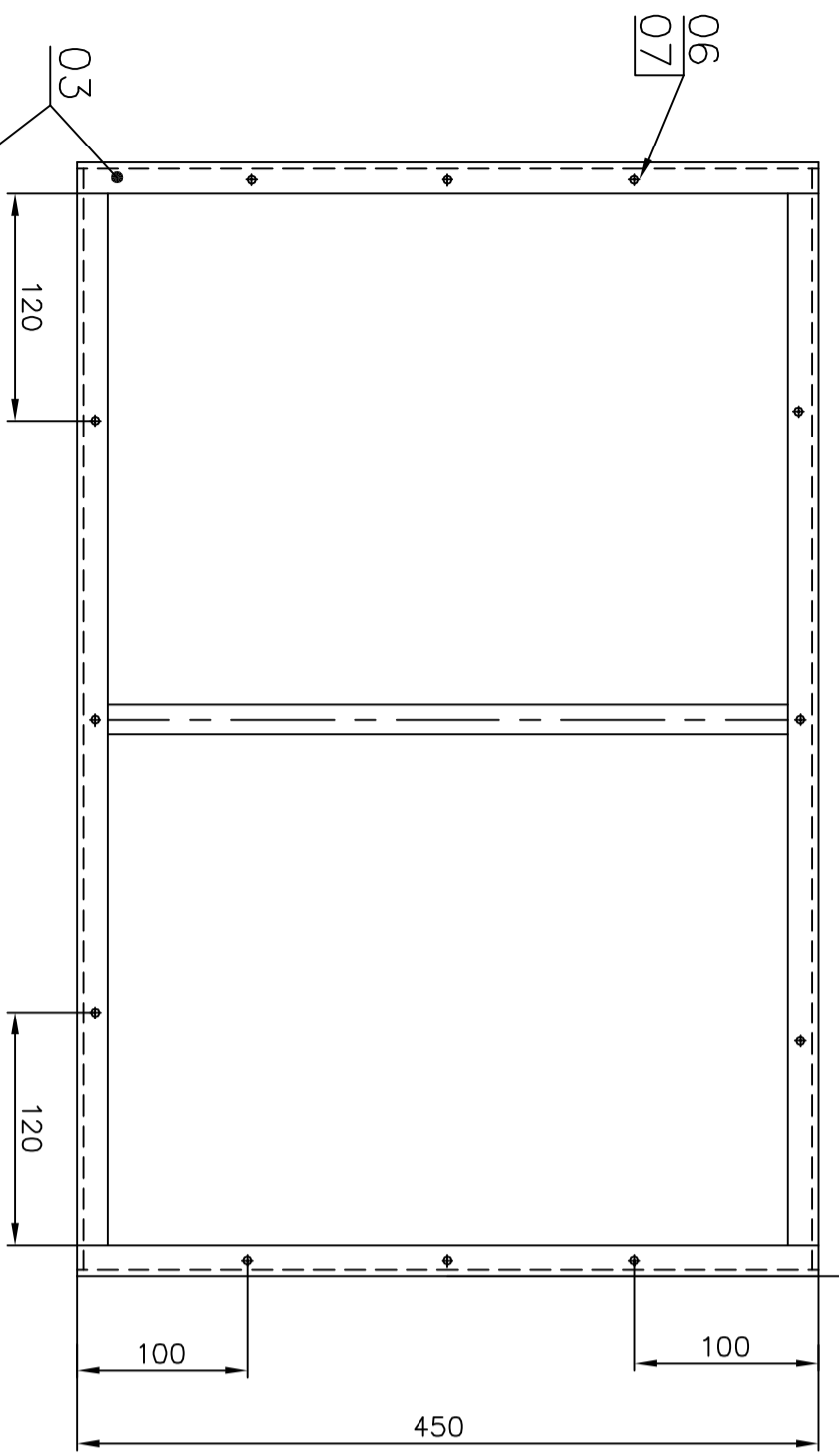

- NOTES:**
01. ALL BOX OPENING SHALL BE CLOSED USING ITEM-04 / 0.63 SHEETS.
 02. SHEET 0.63 SHALL ALSO CAN BE FIXED USING SELF DRILL GUN AND SELF TAPPING SCREWS. TOOL REQUIRED IS SELF DRILL GUN & SCREWS ONLY.
 03. TOP FRAME SHALL BE TACK WELD AT VENDOR WORKS TO ENABLE SHIPPING TO OPEN AND USE.
 04. ONE COAT OF RED OXIDE PAINT IS TO BE APPLIED, TO AVOID RUSTING.
 05. WELD 2A WHEREVER NOT SHOWN.
 06. ITEMS USED A25x25x2.5 COMMERCIAL QUALITY CAN BE USED. FOR MATERIAL SUBSTITUTION USE MATERIALS ON HIGHER SIDE ONLY.
 07. ITEM USED TUBE DIA 42.9X3.25 CAN BE SUBSTITUTED ON HIGHER SIDE ONLY.
 08. LOAD CARRYING CAPACITY: 500Kgs.
 09. FLATS REQUIRED FROM FRONT, TOP & SIDE FRAME BASED ON FEEDBACK FROM SHIPPING.
 10. LENGTH OF CHANNEL SHORTENED TO 450MM DL ZONE E2.
 11. QTY CHANGED FOR ITEM NO.05 BASED ON SHIPPING FEEDBACK.

REV	DATE	ALTERED	BY	REASON
06	17.12.13	CHECKED	C GANESH	
05	17.12.13	CHECKED	SARATHI S	
04	17.12.13	CHECKED	SARATHI S	
03	05.09.12	CHECKED	SARATHI S	
02	25.03.11	CHECKED	SARATHI S	
01	20.05.09	CHECKED	SARATHI S	

REV	DATE	ALTERED	BY	REASON
06	17.12.13	CHECKED	C GANESH	
05	17.12.13	CHECKED	SARATHI S	
04	17.12.13	CHECKED	SARATHI S	
03	05.09.12	CHECKED	SARATHI S	
02	25.03.11	CHECKED	SARATHI S	
01	20.05.09	CHECKED	SARATHI S	

VARIANT NO	ITEM NO	DESCRIPTION	QTY	DRAWING NO.	ITEM NO	MATL. CODE	UNIT WT.	QTY	UNIT WT.	NO. OF VARS	NO. OF VARS
	07	HEX-NUT M10	4			4130400910	0.003	4			
	06	SCRU.&NUT M10X25	4			4125510025	0.038	4			
	05	SH 0.63	4			15-811-715	4.945	4			
	04	FLAT 20X6	1			15-008-207	0.942	1			
	03	TOP FRAME	1			3-79-000-01452	0.90	1			
	02	FRONT FRAME	2			3-79-000-01451	1.414	2			
	01	BOTTOM FRAME	1			3-79-000-01450	9.254	1			

CAUTION: The information on this document is the property of BHARAT HEAVY ELECTRICALS LTD. It must not be used directly or indirectly in any way detrimental to the interest of the company.

TYPE OF PRODUCT: LOAD CARRYING CAPACITY 500KGS.

OR NAME OF CUSTOMER/PROJECT: BHARAT HEAVY ELECTRICALS LTD., UNIT. BOILER AUXILIARIES PLANT, RAIPET - 632 406.

DEPT	ACCOS	GRADE OF UNTOLO DIM	SCALE	WEIGHT (KG)	APPD	NAME	SIGN	DATE	NO. OF VARS
862	500	N.T.S	26.780			A.PARASU	SARATHI S	14.01.2009	
						C.GANESH			
						C.GANESH			

TITLE: TYPE-IV STEEL BOX PACKING ASSEMBLY

CARD CODE: U 01

DRAWING NO.: 2-79-000-01741

REV: 06

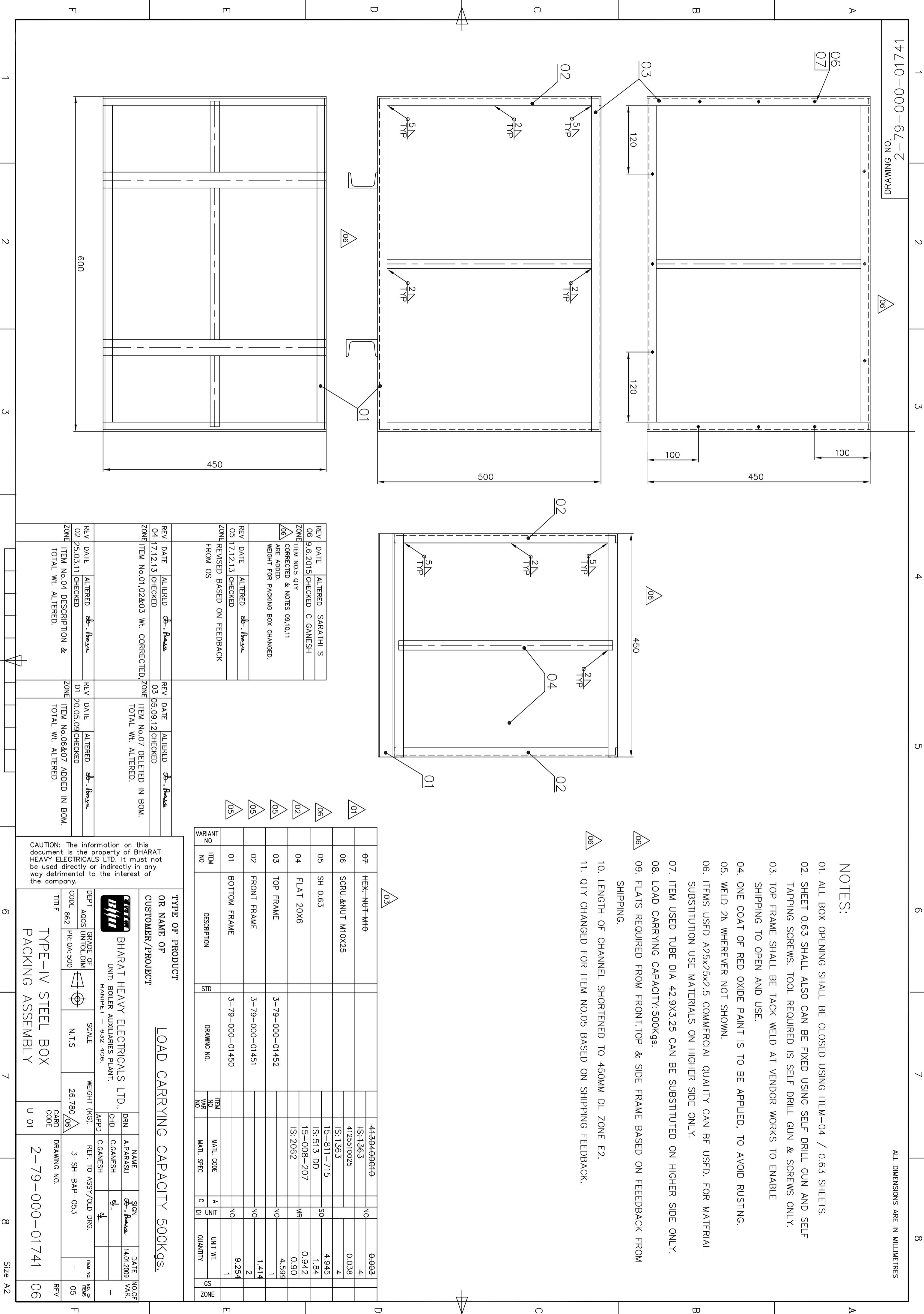

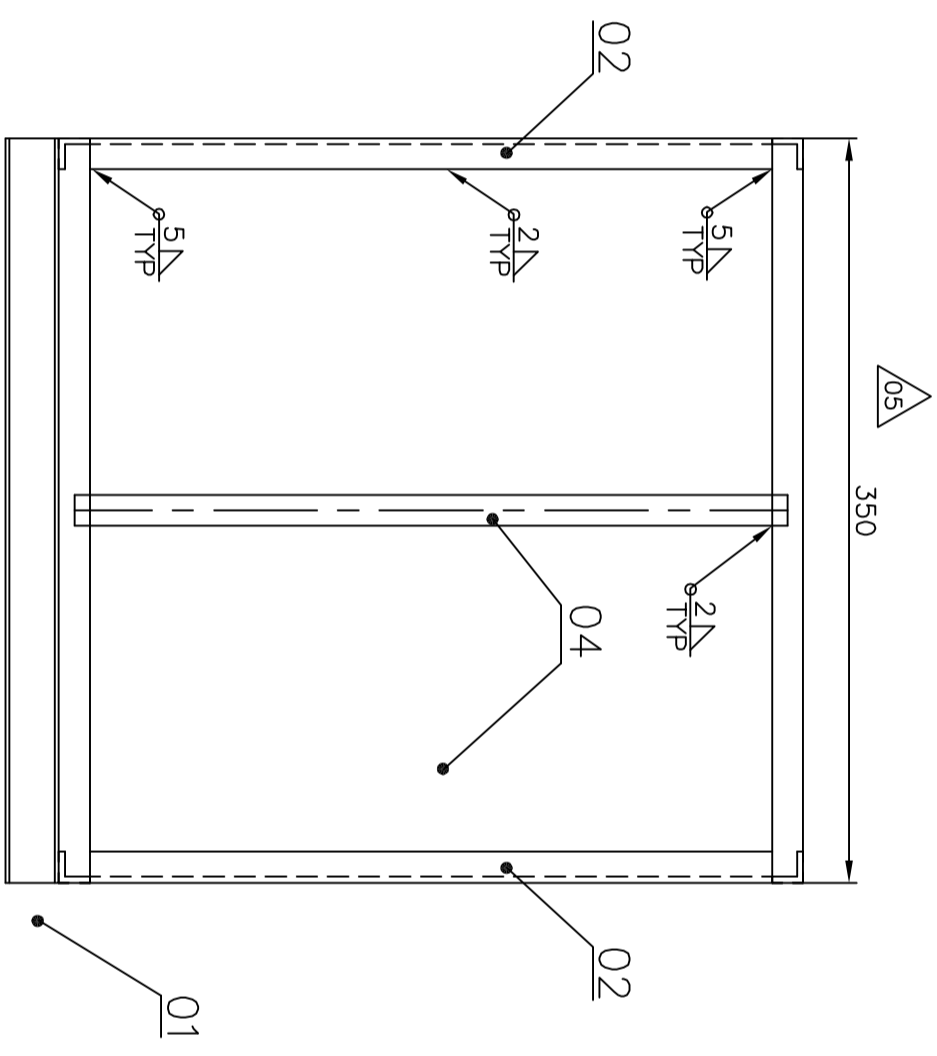
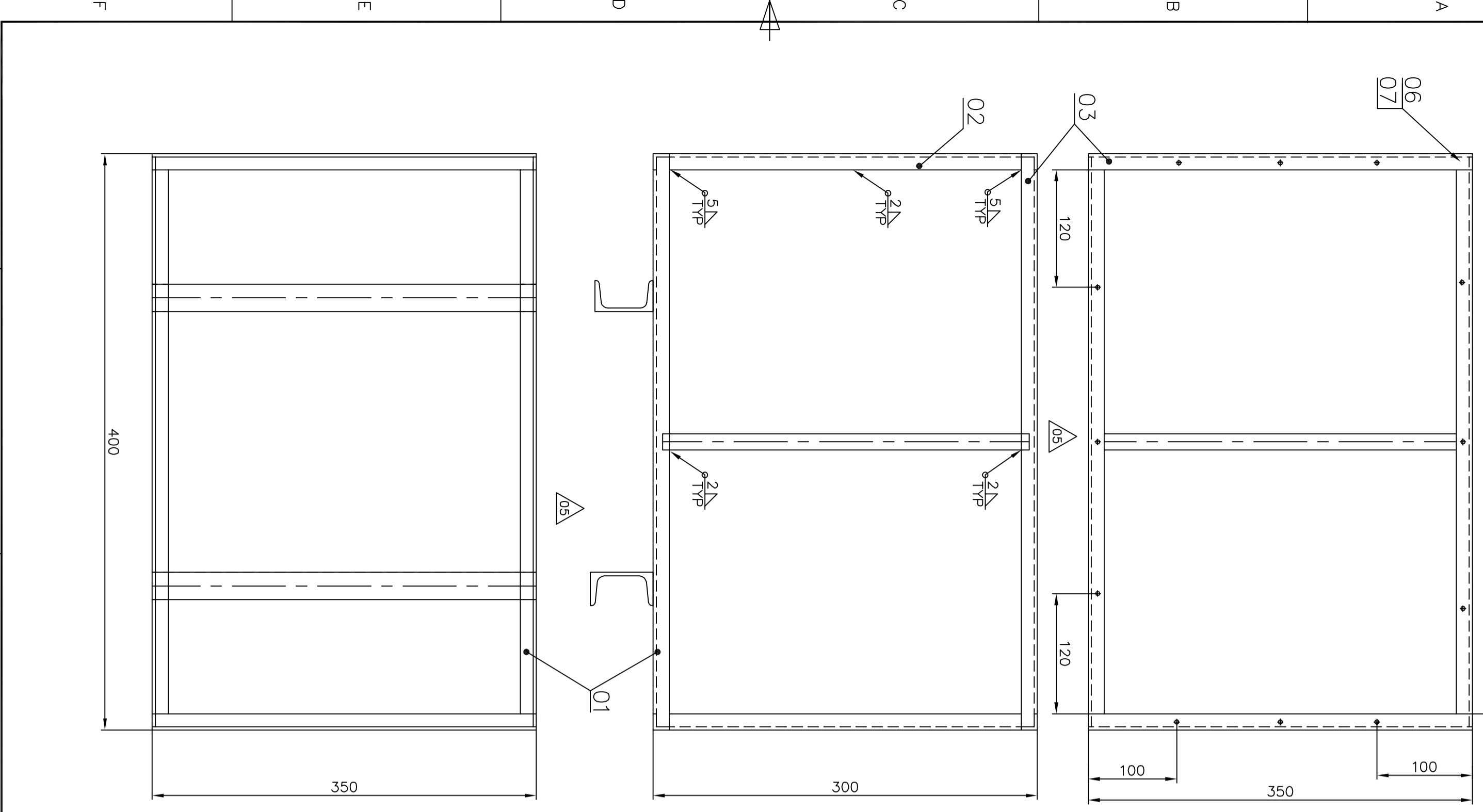

REV	DATE	ALTERED	SMITH S
05	22.05.14	CHECKED	Completed
04	22.05.14	CHECKED	Completed
02	25.03.11	CHECKED	

ZONE ITEM No.5 QTY CORRECTED & NOTES 09.10.11 ARE ADDED.

NOTE: WEIGHT FOR PACKING BOX CHANGED.

VARIANT NO	ITEM NO	DESCRIPTION	DRAWING NO.	ITEM NO. VAR NO	MATL. CODE	MATL. SPEC	UNIT WT.	QUANTITY	REV
01	07	HEX-NUT M10			4130400040		0.003	4	
02	06	SCRU & NUT M10X25			4125510025		0.038	4	
03	05	SH 0.63			IS:1363		4.945	4	
04	04	FLAT 20X6			IS:513 DD		0.840	0.942	
05	03	TOP FRAME	3-79-000-01455		IS:2062	MR	0.15	3.280	
06	02	FRONT FRAME	3-79-000-01454					0.786	
07	01	BOTTOM FRAME	3-79-000-01453					6.648	

- NOTES:**
01. ALL BOX OPENING SHALL BE CLOSED USING ITEM-04 / 0.63 SHEETS.
 02. SHEET 0.63 SHALL ALSO CAN BE FIXED USING SELF DRILL GUN AND SELF TAPPING SCREWS. TOOL REQUIRED IS SELF DRILL GUN & SCREWS ONLY.
 03. TOP FRAME SHALL BE TACK WELD AT VENDOR WORKS TO ENABLE SHIPPING TO OPEN AND USE.
 04. ONE COAT OF RED OXIDE PAINT IS TO BE APPLIED, TO AVOID RUSTING.
 05. WELD 2A WHEREVER NOT SHOWN.
 06. ITEMS USED A25x25x2.5 COMMERCIAL QUALITY CAN BE USED. FOR MATERIAL SUBSTITUTION USE MATERIALS ON HIGHER SIDE ONLY.
 07. ITEM USED TUBE DIA 42.9X3.25 CAN BE SUBSTITUTED ON HIGHER SIDE ONLY.
 08. LOAD CARRYING CAPACITY: 200Kgs.
 09. FLATS REQUIRED FROM FRONT TOP & SIDE FRAME BASED ON FEEDBACK FROM SHIPPING.
 10. LENGTH OF CHANNEL SHORTENED TO 450MM DL ZONE E2.
 11. QTY CHANGED FOR ITEM NO.05 BASED ON SHIPPING FEEDBACK.

REV	DATE	ALTERED	By: Pankaj
04	22.05.14	CHECKED	Completed
03	05.09.12	CHECKED	
02	25.03.11	CHECKED	

ZONE ITEM No.01 to 03 WT corrected.

ZONE ITEM No.07 DELETED IN BOM.

ZONE ITEM No.04 DESCRIPTION & TOTAL WT. ALTERED.

ZONE ITEM No.06&07 ADDED IN BOM. TOTAL WT. ALTERED.

CAUTION: The information on this document is the property of BHARAT HEAVY ELECTRICALS LTD. It must not be used directly or indirectly in any way detrimental to the interest of the company.

TYPE OF PRODUCT OR NAME OF CUSTOMER/PROJECT

LOAD CARRYING CAPACITY 200KGS.

DEPT ACOES	GRADE OF UNTO L DIM	SCALE	WEIGHT (KG)	DRN A.PARASU	NAME	SIGN	DATE
862	PR: 0A: 500	N.T.S	16.277	CHD C.GANESH	C.GANESH	dl	14.01.2009
BHARAT HEAVY ELECTRICALS LTD., UNIT: BOILER AUXILIARIES PLANT, RAIPUR - 832 406.				APRD C.GANESH	REF. TO ASSY/OLD DRG.		
TYPE-V STEEL BOX PACKING ASSEMBLY				U 01	DRAWING NO. 2-79-000-01742	REV 05	