

Name of Woks: WORKS CONTRACT FOR SHOT BLASTING AND PAINTING OF STEAM GENERATOR AT ATP, BHEL-TRICHY

Enquiry No: 9001700001 /06.01.2017

**BHARAT HEAVY ELECTRICALS LIMITED
TIRUCHIRAPPALLI-620 014
WORKS CONTRACTS MANAGEMENT**

NOTICE INVITING TENDER

1.	Tender Ref No:	9001700001/06.01.2017
2.	Name of works	WORKS CONTRACT FOR SHOT BLASTING AND PAINTING OF STEAM GENERATOR AT ATP,BHEL-TRICHY
3.	Location of work	BHEL, TRICHY.
4.	Period of contract	03 months from the date of award of contract.
5.	Earnest Money Deposit	₹ 9,870/-
6.	Tender Document details	A] Technical Bid Part-1A (Technical Bid-Qualifying Criteria) - 02 Pages. Part-1B (Scope of Work and Technical Terms & Conditions) - 03 Pages. Part-1C (General Terms & Conditions of Contract) - 13 Pages B] Price Bid Part-2 (Price bid) - 01 Page.
7.	Address for Sending Tender Document along with EMD.	Senior Manager Works Contracts Management (WCM) Building 53,First Floor, BHEL-High Pressure Boiler Plant, Trichy - 620 014
8.	Last Date for submission of Tender Document	27.01.2017 / 10:00 Hrs.
9.	Date of Techno Commercial Bid Opening	27.01.2017 / 10:30 Hrs.
10.	Date of Price Bid Opening	Will be intimated separately to Technically qualified vendors.

Name of Woks: WORKS CONTRACT FOR SHOT BLASTING AND PAINTING OF STEAM GENERATOR AT ATP, BHEL-TRICHY

Enquiry No: 9001700001 /06.01.2017

INSTRUCTIONS TO THE TENDERERS

The offer should be addressed to SENIOR MANAGER, Works Contracts Management, 53 Building, BHEL, Tiruchirappalli 620 014, to reach WCM Dept. on or before 27.01.2017 at 10:00 Hrs. or the same may be dropped in the Tender Box kept at Works Contracts Management, 53 Building, BHEL, Tiruchirappalli 620 014.

Tenders will be opened on 27.01.2017 at 10:30 Hrs. (IST) at Works Contracts Management, 53 Building, BHEL, Tiruchirappalli 620 014. BHEL shall not responsible for any postal delay.

Bidder has to submit (1) Part-I (Techno-Commercial bid) (2) Part-II (Price bid) & (3) EMD draft in separate covers.

- a. The first envelope shall contain DD / Pay order drawn in favor of BHEL, Trichy as EMD and super scribed as EMD Cover for NIT / Enquiry No.

Note: **1. Offer without EMD will be rejected**

2. EMD may be submitted in the form of DD/Pay Order /Bankers Cheque drawn in favor of BHEL, Trichy (along with offer) or Electronic Fund Transfer credited in BHEL account (before Tender opening). EMD in any other form (Like FD / One Time EMD etc.) is not acceptable.

- b. The second envelope shall be sealed and super scribed as Part-I (Technical Bid for NIT/Enquiry No.)

- c. The third envelope shall contain only Part-II (Price bid) for the above work as per scope and to be quoted as per the format given in price bid. Any other information in price bid will not be considered. The envelope shall be sealed and super scribed as Price Bid for NIT / Enquiry No.

All the above three envelopes shall be kept into one cover ,sealed and super scribed as Tender Document for the work as per NIT (NIT/Enquiry No).

Note:

1. The contract will be awarded for a period of 03 months from the date of ordering.
2. The quoted rates shall be valid up to six months from date of Tender opening.
3. The rates shall remain firm for the entire period of the contract in case WO is awarded.
4. If the Contractor back outs after opening of tender, the contractor is liable for forfeiture of the EMD paid.
5. **Evaluation of the offer shall be done on "Net Cash outflow to BHEL after taking into account applicable Taxes and Duties".**
6. BHEL reserves the right to increase or decrease the tendered quantity.
7. **BHEL does not guarantee any minimum quantity.**
8. Income Tax deduction at source as applicable in the IT Act from time to time will be made on the value of the bills in the absence of Income Tax Exemption Certificate from the concerned IT officer.
9. All the Statutory Obligations such as ESI, PF, Labor Acts, Factories Act, Service Tax, etc. will have to be taken care of by the vendor. BHEL will have no liability on them. Notwithstanding the above, if any demand notice is served by the concerned Statutory Authorities for recovery of any of their dues on BHEL, the same would be paid to the statutory authorities without notice to the vendor and recovered as a due from any pending / future bills.
10. In case contract is not executed by vendor after award and acceptance of contract, BHEL may exercise the right to forfeit EMD, Security Deposit / BG of such contractors and also suitable action will be taken by BHEL on those Contractors as deemed fit.

Name of Woks: WORKS CONTRACT FOR SHOT BLASTING AND PAINTING OF STEAM GENERATOR AT ATP, BHEL-TRICHY

Enquiry No: 9001700001 /06.01.2017

PART-I (TECHNO COMMERCIAL BID)

ANNEXURE-1A

A: Bidder Profile

1.	Name of the Agency /Company /vendor.	
2.	Address:	
3.	Phone No.:	
4.	E-mail Address:	
5.	Name and Contact details of person for communication related to Tender :	
6.	BHEL Vendor Code (If any)	
7.	PF Registration (No. & Date) (Copy of PF Registration to be attached)	
8.	ESI Registration (No. & Date) (Copy of ESI Registration to be attached)	

Note:

- 1. Vendors not having PF Registration /ESI Registration / Labour License (as applicable) shall immediately get registered after award of work to comply with statutory requirements.**
- 2. If vendor fails to get PF / ESI Registration and Labour License (As applicable) within 30 days of award of work, EMD / SD shall be forfeited and penal action shall be taken as per Extant rules of BHEL.**

Contractor Signature

Contractor Seal

Name of Woks: WORKS CONTRACT FOR SHOT BLASTING AND PAINTING OF STEAM GENERATOR AT ATP, BHEL-TRICHY

Enquiry No: 9001700001 /06.01.2017

B: Qualifying Criteria:

Sl. No	Qualifying Criteria	DETAILS
A	<p>EMD(Earnest Money Deposit) : Amount: ₹ 9,870 /- (Offer without EMD will be rejected.) (EMD will be waived off for SME/NSIC/SSI vendors upon verification.) (Copy of valid Certificate to be enclosed)</p>	<p>AMOUNT :₹ DD NO: DD DATE: ISSUING BANK :</p>
B	<p>Technical Competence : The requisite experience shall be as follows:</p>	
B.1	<p>Experience of execution of at least one contract related to Shot blasting and spray painting. (Vendor shall submit documentary evidence for the same in form of WO / Contract agreement / Completion report / Inspection report)</p>	
C	<p>Income Tax Registration : Income Tax registration Number (Copy of PAN to be attached)</p>	
D	<p>Service Tax Registration. Service Tax Registration Number (Copy of Service Tax Registration to be attached) (In case Bidder is exempted from Service Tax, Self - Declaration to be attached.)</p>	
E	<p>Acceptance to Scope of Work (Annexure-1B) and General Terms & Conditions of Contract (Annexure-1C).</p>	
		Contractor Signature
		Contractor Seal

PART-I (TECHNO COMMERCIAL BID)

Name of Vendor:

SCOPE OF WORK AND TECHNICAL TERMS & CONDITIONS

A. BILL OF QUANTITY

SN	Work Description	UOM	QTY
1	Pre-treatment, shot blasting and painting of 700MW Steam Generator inside assembly shop at BHEL,Trichy	No.	1

SCOPE OF WORK

1. Scope of Work

Pre-treatment, shot blasting and painting of 700MW Steam Generator inside BHEL assembly shop.

2. General requirements

- a. Job (Steam Generator) will be provided by BHEL placed inside shop floor on rotators.
- b. Vendor to erect scaffolding structures, etc. and cover it to create a temporary covered region
- c. Refer Drawing 3-HE-170-02703 for dimensions of the job / equipment.
- d. The contractor should employ painters with experience in spray painting process.

3. Pre-Treatment

- a. Cleaning of entire outer surface to free the surface from oil, grease and other external contaminants
- b. Surface shall be thoroughly cleaned using solvents like acetone or trichloroethylene or any other equivalent petroleum solvents.
- c. Inspection of surface by BHEL & NPCIL to ensure removal of grease / oil by Water Film Break Test.
- d. The areas, where the water is not uniformly wetting and shattering into tiny droplets shall be further cleaned with alkaline degreasing agent.
- e. Only those areas cleaned with alkaline degreasing agent shall be rinsed with water till the surface is free of alkali and then dried. Water film break test shall be further conducted in these areas to ensure the total removal of grease / oil.

Contractor Signature

Contractor Seal

Name of Woks: WORKS CONTRACT FOR SHOT BLASTING AND PAINTING OF STEAM GENERATOR AT ATP, BHEL-TRICHY

Enquiry No: 9001700001 /06.01.2017

4. Scaffolding & Covering

- a. Rigid structures should be erected for scaffolding covering the entire Steam Generator area of approximately L-30m x W-6m x H-6m.
- b. Covering over scaffolding shall be preferably of rubber sheets or thick tarpaulin or any other protective cover to prevent the shots leakage.
- c. Rotators on which the job is supported is to be protected suitably during shot blasting
- d. Adequate light and ventilation arrangements to be provided for the covered area for the safety of the personnel working inside
- e. All shots/grits to be completely cleaned and collected after completion of blasting. Area to be completely cleaned when scaffolding is removed after completion of job

5. Shot Blasting

- a. Blasting of the surface with a surface finish of SA 2 1/2 finish.
- b. Blasting media shall comprise of steel shots + grits in a mixing ratio of approximately 3:1 to achieve the required surface roughness of 25-40 microns.
- c. Inspection of surface finish shall be done by BHEL

6. Power Tool Cleaning (if necessary)

- a. Wherever blast cleaning is not possible due to design configuration power tool cleaning shall be done by mechanical surface preparation methods like hand grinding, wire brushing, disc sanders etc. to minimum St3 grade.
- b. Power wire brushing shall be taken care to avoid the risk of polishing the surface. The surface shall appear rough and matt.

7. Painting (DFT 40 microns)

- a. 'Airless Spray painting' process shall be used for painting with Heat Resistant Aluminum Paint Grade II.
- b. First coat of painting to be done within 4 hours of inspection clearance
- c. First coat shall be applied and should be allowed to cure for 48 hours.
- d. DFT check to ensure 20 microns thickness after first coat.
- e. Second coat of paint to be done after 48 hours of first coat and cured for 24 hours.
- f. DFT check to ensure final thickness of 40 microns (cumulative coats)

Contractor Signature

Contractor Seal

Name of Woks: WORKS CONTRACT FOR SHOT BLASTING AND PAINTING OF STEAM GENERATOR AT ATP, BHEL-TRICHY

Enquiry No: 9001700001 /06.01.2017

- g. In case the measured DFT of coating surface is not adequate, in some locations they shall be roughened by manual cleaning (emery paper, wire brushing etc) then touch up painting shall be done preferably by spray or brush to the required DFT as specified.
- h. Peel off test shall be done by BHEL

8. Scope of BHEL

- a. Compressed air at 5 to 5.5 bar shall be provided near to job
- b. Power for lighting and other requirements shall be provided at single point near the job
- c. Required quantity of Acetone, degreasing powder (maxi clean) Cotton waste, White cloth for pre treatment
- d. Tools such as grinding machine, buffing wheels, emery papers for power tool cleaning
- e. Heat Resistant Aluminum Paint – Grade II

9. Scope of Vendor

- a. All tools / equipment, consumables and raw materials required for blasting and spray painting such as
 - a. Shot blasting equipment with adequate hoses.
 - b. Adequate quantity of steel shots and grits
 - c. Airless spray painting equipment
 - d. Paint stirring equipment
- b. Necessary safety and personnel protective equipment.
- c. Scaffolding structures and covers.
- d. Required skilled manpower for blasting and experienced painters for spray painting.
- e. One supervisor to be present throughout till completion of job for all necessary coordination
- f. Pretreatment, blasting and painting to be completed within 1 week from the time SG is handed over to the vendor

Contractor Signature

Contractor Seal

PART-I (TECHNO COMMERCIAL BID)

ANNEXURE-IC

Name of Vendor:

GENERAL TERMS & CONDITIONS OF CONTRACT

1. Definition:

In these General Conditions of Contract, the following terms shall have, I meaning hereby assigned to them, except where the context otherwise requires:

- a) The "Contract" means, the documents forming the tender and acceptance thereof, together with all the documents referred to therein including general and special conditions to contract. All these documents as applicable taken together shall be deemed to form one contract and shall be complementary to one another.
- b) The "Work" means, the work described in the tender documents in individual work orders as may be issued from time to time to the contractor by the Officer-In charge within the power conferred upon him including all notified or additional items of works and obligations to be carried out as required for the performance of contract.
- c) The "contractor" means, the individual Firm or Company whether incorporated or not, undertaking the work and shall include the legal personal representatives of such individuals or the persons composing the firm or Company or the successors of the firm or company and the permitted assigns of such individual or firm or Company.
- d) "The Officer-In charge" means, the Officer deputed by the respective area **HOD** to supervise the work or part of the work.
- e) "Approved" and "Directed" means, the approval or direction of the respective area **HOD** or person deputed by him for the particular purposes.
- f) "BHARAT HEAVY ELECTRICALS LIMITED" (hereinafter referred to as BHEL) shall mean the Board of Directors, Chairman, Executive Director, General Manager or, other Administrative Officer of the said Company including Sr.Manager / WCM authorised to invite tenders and enter into contract for works on behalf of the Company.
- g) The "Contract sum" means, the sum accepted or the sum calculated in accordance with the prices accepted in tender and / or the contract rates as payable to the contractor for the execution of the work during the currency of the contract.
- h) A "week" means, Seven Days, without regard to the number of hours worked or not worked in any day in that week.
- i) A "day" means, the day of 24 hours (TWENTY FOUR) irrespective of the number of hours worked or not worked in that day.

Contractor Signature

Contractor Seal

Name of Woks: WORKS CONTRACT FOR SHOT BLASTING AND PAINTING OF STEAM GENERATOR AT ATP, BHEL-TRICHY

Enquiry No: 9001700001 /06.01.2017

2. Heading to the Contract Conditions:

The heading to these conditions shall not affect the interpretations thereof.

3. Work To Be Carried Out:

The Contract shall include all labour which may be required for the execution of the work.

The Contractor will be deemed to have satisfied himself as to the nature of the site, local facilities of access and all matters affecting the execution of the work. No. extra charges consequent on any misunderstanding in these respects or otherwise will be allowed.

4. Deviations:

The contractor shall carry out any Scope of work as per instructions of Executing official.

5. Assignment of Transfer of Contract:

The Contractor shall not, without the prior written approval of the BHEL, assign or transfer the contract or any part thereof, or any share, or interest thereon to any other persons. No sum of money which may become payable under the contract shall be payable to any person, other than the contractor unless the prior written approval of the BHEL to the assignment or transfer of such money is given.

6. Sub-Contract:

The Contractor shall not sublet any portion of the contract without the prior written approval of the BHEL.

7. Compliance to Regulations and Bye-Laws:

The Contractor shall confirm to the provisions of any statute relating to the work and regulations and Bye- laws of any local authority. The Contractor shall be bound to give all notices required by statutory regulations or by-laws as aforesaid and to pay all fees and taxes payable to any authority in respect thereof.

8. Earnest Money Deposit (EMD) & Security Deposit (SD):

Earnest Money Deposit (EMD):

Tender must be accompanied by Earnest Money for the amount mentioned in tender notice, pledged to BHEL, Trichy in any of the forms mentioned below.

Modes of Deposit:

The EMD shall be accepted only in the following forms:

- a) Cash deposit as permissible under the extant Income Tax Act (before tender opening)
- b) Electronic Fund Transfer credited in BHEL account (before tender opening)
- c) Banker's cheque/ Pay order/ Demand draft, in favour of BHEL (along with offer)

In case total EMD amount is more than ₹ 20 Lakh, the amount in excess of ₹ 20 lakh may be accepted in the form of Bank Guarantee from scheduled bank. The Bank Guarantee in such cases shall be valid for at least six months.

Forfeiture of EMD:

EMD by the tenderer will be forfeited as per tender documents if

- i) After opening the Tender, the Tenderer revokes his Tender within the validity period or increase his earlier quoted rates.

Contractor Signature

Contractor Seal

Name of Woks: WORKS CONTRACT FOR SHOT BLASTING AND PAINTING OF STEAM GENERATOR AT ATP, BHEL-TRICHY

Enquiry No: 9001700001 /06.01.2017

- ii) If only, a part of the work included in the tender has been awarded to the tenderer and the tenderer refuses to take up the work the amount of Earnest Money to be forfeited will be based on the value of the contract so awarded.
- iii) The Tenderer does not commence the work within the period as per LOI / Contract. In case the LOI / Contract is silent in this regard then within 15 days after award of Contract.

General Terms related to EMD:

Earnest Money Deposit (EMD) will not carry any interest.

Earnest Money Deposit (EMD) of the successful tenderer will be retained as part of Security deposit. The Earnest Money Deposit (EMD) will be refunded to the unsuccessful tenderers within 15 days of acceptance of the award of work by successful tenderer / expiry of offer validity period

Security Deposit (SD):

The contractor whose tender has been accepted shall, within seven days of receipt of the notification of acceptance of his tender, should deposit Security deposit @ 5 % of Contract value.

EMD of the successful tenderer shall be converted and adjusted towards the required amount of Security deposit (SD):

Modes of Deposit:

The balance amount to make up the required Security Deposit of 5% of the contract value may be accepted in the following forms:

- i) Cash (as permissible under the extant Income Tax Act)
- ii) Local cheques of Scheduled Banks (subject to realization)/ Pay Order/ Demand Draft/ Electronic Fund Transfer in favour of BHEL
- iii) Bank Guarantee from Scheduled Banks/ Public Financial Institutions as defined in the Companies Act. The Bank Guarantee format should have the approval of BHEL
- iv) Fixed Deposit Receipt issued by Scheduled Banks/ Public Financial Institutions as defined in the Companies Act (FDR should be in the name of the Contractor, a/c BHEL)
- v) Securities available from Indian Post offices such as National Savings Certificates, Kisan Vikas Patras etc. (held in the name of Contractor furnishing the security and duly endorsed/ hypothecated/ pledged, as applicable, in favor of BHEL)

General Terms related to SD:

The security Deposit will not carry any interest.

Security Deposit shall be released to the contractor upon fulfilment of Contractual obligations as per terms of contract.

BHEL, shall not be responsible for any loss of securities due to liquidation or any other reason whatsoever or any depreciation in the value of the Securities while in their charge or for any loss of interest thereon.

Contractor Signature

Contractor Seal

Name of Woks: WORKS CONTRACT FOR SHOT BLASTING AND PAINTING OF STEAM GENERATOR AT ATP, BHEL-TRICHY

Enquiry No: 9001700001 /06.01.2017

NOTE: Acceptance of Security Deposit against Sl. No. (iii),(iv) and (v) above will be subject to hypothecation or endorsement on the documents (Signature of the Branch Manager must be present) in favor of BHEL. However, BHEL will not be liable or responsible in any manner for the collection of interest or renewal of the documents or in any other matter connected therewith.

All compensation or other sums of money payable by the contractor to BHEL under the terms of this contract or under any other contract with BHEL, may be deducted from the Security Deposit or realized by the sale of the securities or from the interest arising there from or from any sums which may be due or may become due to the contractor payable by BHEL, on any account whatsoever against this contract or any other contract with BHEL and in the event of his Security Deposit being reduced by reason of such deductions or sale as aforesaid, the Contractor shall within seven days thereafter make good in cash or in securities endorsed as aforesaid, any sum or sums by which the security Deposit has been so reduced.

In case of an Award of a Contract and if the Contractor fails to perform or does not comply with the Performance Evaluation Criteria, the Security Deposit will not be refunded / Bank Guarantee encashed.

The Bank Guarantee shall be kept valid until the due date for refund of Security Deposit.

Security Deposit has to be deposited within 15 days of LOI/WO. Else EMD will be forfeited and may also attract the provision of "Suspension of Business dealings with Suppliers/Contractors".

9. MSE VENDORS:-

MSE suppliers can avail the intended benefits only if they submit along with the offer, attested copies of either EM II certificate having deemed validity (Five years from the date of issue of acknowledgement in EM-II) or valid NSIC certificate or EM II certificate along with attested copy of a CA certificate (Format is provided as Annexure-A where deemed validity of EM II certificate of five years has expired) applicable for the relevant financial year (latest audited). Date to be reckoned for determining the deemed validity will be the date of bid opening (Part 1 in case of two part bid). Non submission of such documents will lead to consideration of their bids at par with other bidders. No benefit shall be applicable for this enquiry if any deficiency in the above required documents are not submitted before price bid opening. If the tender is to be submitted through e-procurement portal, then the above required documents are to be uploaded on the portal. Documents should be notarized or attested by a Gazetted officer.

Contractor Signature

Contractor Seal

Name of Woks: WORKS CONTRACT FOR SHOT BLASTING AND PAINTING OF STEAM GENERATOR AT ATP, BHEL-TRICHY

Enquiry No: 9001700001 /06.01.2017

Annexure-A

Certificate by Chartered Accountant on letter head

This is to certify that M/s. _____ (hereinafter referred to as „company“) having its registered office at _____ is registered under MSMED Act 2006, (Entrepreneur Memorandum No (Part II)) _____ dtd. _____, Category :____(Micro/Small). (Copy enclosed).

Further verified from the Books of Accounts that the investment of the company as per the latest audited financial year _____ as per MSMED Act 2006 is as follows:

- 1. For Manufacturing Enterprises:** Investment in plant and machinery (i.e. original cost excluding land and building and the items specified by the Ministry of Small Scale Industries vide its notification No. S.O.1722(E) dated October 5, 2006):

₹ _____ Lacs

- 2. For Service Enterprises:** Investment in equipment (original cost excluding land and building and furniture, fittings and other items not directly related to the service rendered or as may be notified under the MSMED Act 2006):

₹ _____ Lacs

(Strike off whichever is not applicable)

The above investment of ₹ _____ Lacs is within permissible limit of ₹ _____ Lacs for _____ Micro / Small (Strike off which is not applicable) Category under MSMED Act 2006.

Or

The company has been graduated from its original category (Micro/Small) (Strike off which is not applicable) and the date of graduation of such enterprise from its original category is (dd/mm/yyyy) which is within the period of 3 years from the date of graduation of such enterprise from its original category as notified vide S.O. No. 3322(E) dated 01.11.2013 published in the gazette notification dated 04.11.2013 by Ministry of MSME.

Date:

(Signature)

Name:

Membership number:

Seal of Chartered Accountant

Place:

Date:

Contractor Signature

Contractor Seal

Name of Woks: WORKS CONTRACT FOR SHOT BLASTING AND PAINTING OF STEAM GENERATOR AT ATP, BHEL-TRICHY

Enquiry No: 9001700001 /06.01.2017

10. Orders under the Contract:

All orders, notices etc. to be given under the contract shall be in writing, typescript or printed and if sent by registered post to the address given in the tender of the Contract, shall be deemed to have been served on the date, when in the ordinary course they would have been delivered to him. The Contractor shall carry out without delay all orders given to him.

Contractor shall be deemed to have included in his tender price of all the plant, machinery and appliances required for the purpose of all operations connected with the work embraced under the contract to secure a satisfactory quality of work and rate of progress which in the opinion of the " Contract Signing Officer" will ensure the completion of the work within the time specified. BHEL is having every right to split the schedule and to award the work to single or many parties on the lowest offered rates basis. This is a time bound contract for period mentioned, and does not envisage any extension of time / period.

11. Contractor's Supervision:

1. The Contractor shall either himself supervise the execution of the contract or shall appoint a competent agent acceptable to BHEL Officials.
2. Orders given to the Contractor's agent shall be considered to have the same force as if they have been given to the Contractor himself.
3. The Contractor or his accredited agent shall attend when required without making any claim for doing so to the OFFICER-INCHARGE, to receive instructions.
4. The respective area HOD shall have full powers and without assigning any reason, requires the Contractor to immediately cease to employ in connection with this contract, any agent, servant or employee where continued employment is, in his opinion undesirable. The Contractor shall not be allowed any compensation on this account.

12. Labour:

1. The Contractor shall remain liable for the payment of all wages and other payments in connection with the employees engaged by him and with regard to the work.
2. The Contractor shall comply with the applicable provisions of Payment of Wages Act, 1936, Minimum Wages Act, 1948, Employees Liability Act. 1938, Employees' Compensation Act 1923, Payment of Bonus Act, EPF and Miscellaneous Provisions Act, 1952, Employees State Insurance Act, 1948 and other relevant Acts and rules framed, there under from time to time
3. Contractor shall be responsible for making payment of wages before expiry of 7days from the last day of wage period and shall ensure disbursement of wages in the presence of the authority's representative of contract operating division who shall record under his signature at the end of entries in the Register of wages.
4. Contractor shall have/ obtain license under CL(R&A) Act, 1970.
5. As per BHEL circular HR-Welfare circular dt 08.04.2014, the following additional wages per month has to be paid by the Contractor over and above minimum wages declared by Tamil Nadu Government to labors as:
 - a) Unskilled : Rs. 3200/
 - b) Semi-skilled : Rs. 3700/-
 - c) Skilled : Rs. 4100/-

Contractor Signature

Contractor Seal

Name of Woks: WORKS CONTRACT FOR SHOT BLASTING AND PAINTING OF STEAM GENERATOR AT ATP, BHEL-TRICHY

Enquiry No: 9001700001 /06.01.2017

6. The contractor should remit the salary/wages of their employee only through Bank, directly to the salary/savings account of the employee concerned. The relevant Bank statement/proof for Bank payment should be produced along with PF and ESI challans every month.

13. Precautions against Risk:

The Contractor shall be responsible for providing at his own expense for all precautions to prevent loss or damage from any and all risks and to minimize the amount of any such loss or damage and for the necessary steps to be taken for the said purpose.

14. Damage & Loss to Private Property & Injury to workmen:

The Contractor shall at his own expense reinstate and make good to the satisfaction of the respective area HOD and pay compensation for any injury, loss or damage occurred to any property or rights whatever including property and rights of BHEL (or agents) servants or employee of BHEL, the injury loss or damage arising out of or in any way in connection with the execution or purported execution of the contract and further the contractor shall indemnify BHEL against all claims enforceable against BHEL (or any agent, servant or employee of BHEL) or which would be so enforceable against BHEL, in respect of any such injury (including injury resulting in death) loss or damage to any person whomsoever or property including all claims which may arise under the Employees Compensation Act or otherwise.

15. Laws Governing the Contract:

The contract shall be governed by the Indian Laws for the time being in force.

16. Cancellation of Contract for Corrupt Acts:

BHEL, whose decision shall be final and conclusive, shall without prejudice to any other right or remedy which shall have accrued, shall accrue thereafter to BHEL cancel the contract in any of the following cases and the Contractor shall be liable to make payment to BHEL for any loss or damage resulting from any such cancellation to the same extent as provided in the case of cancellation for default.

If the Contractor shall:

a) Offer or give or agree to give to any person in BHEL service any gift or consideration of any kind, as an inducement or reward for doing or for bearing to do or for having done or for having borne to do any act, in relation to the obtaining or execution of this or any other contract for BHEL service,

OR

b) enter into a contract or understanding with any person in BHEL in connection with which commission has been paid or agreed to be paid by him or with his knowledge, unless the particulars of any such commission and the terms of payment thereof have previously been disclosed in writing to BHEL,

Contractor Signature

Contractor Seal

Name of Woks: WORKS CONTRACT FOR SHOT BLASTING AND PAINTING OF STEAM GENERATOR AT ATP, BHEL-TRICHY

Enquiry No: 9001700001 /06.01.2017

OR

c) To obtain' a contract with BHEL as a result of ring tendering or by non-bonafide methods of competitive tendering, without first disclosing the fact in writing to BHEL.

17. Cancellation of Contract for Insolvency Assignment of Transfer or Subletting Of Contract:

BHEL, without prejudice to any other right or remedy, which shall have accrued or shall accrue thereafter to BHEL, shall cancel the contract in any of the following cases:

If the Contractor,

a) Being an individual or if a firm any partner thereof shall at any time be adjudged bankrupt or have a receiving order for administration of his estate, made against him or shall take any proceedings for liquidation or composition under any bankruptcy Act or assignment of his effects of composition or arrangement for the benefit of his creditors or purport to do so, or if any application made under any Bankruptcy Act for the time being in force for the sequestration of his estate or if a trust deed be granted by him on behalf of his creditors.

OR

b) Being a Company, shall pass a resolution or Court shall make an order for the liquidation of its assets, or a receiver or Manager on behalf of the debenture holders shall be appointed or circumstances shall a rise which entitle the Court or debenture holders to appoint a receiver or Manager.

OR

c) Assigns, Transfers, Sublets or attempts to assign, transfer or sublet any portion of the work without the prior written approval of the BHEL.

d) Whenever BHEL exercises the authority to cancel the contract under these conditions, BHEL may have the work done by any means at the Contractor's risks and expenses provided always that in the event of the cost of the work so done (as certified by the respective area **HOD**) being less than the contract cost, the advantage shall accrue to BHEL and if the cost exceeds the money due to Contractor under the contract, the Contractor shall either pay the excess amount ordered by the respective area **HOD** or the same shall be recovered from the Contractor by other means.

e) In case BHEL carries out the work under the provisions of this condition, the cost to be taken into account in determining the excess cost to be charged to the Contractor under this condition shall consist of the cost of the materials, hire charges of tools and plants and / or labour provided by BHEL with an addition of such percentage to cover superintendence and establishment charges as may be decided by the respective area **HOD** whose decision shall be final and conclusive.

f) Labour engaged by the contractor should be disciplined & exhibit good behaviour in dealing with employees of BHEL. Any misbehaviour or undesirable conduct of any person engaged by the contractor is reported, contractor shall change that person immediately or else it may even lead to termination of the contract & in such case security deposit will be forfeited as penalty.

Contractor Signature

Contractor Seal

Name of Woks: WORKS CONTRACT FOR SHOT BLASTING AND PAINTING OF STEAM GENERATOR AT ATP, BHEL-TRICHY

Enquiry No: 9001700001 /06.01.2017

18. Cancellation of Contract In Part or Full for Contractor's Default:

If the contractor:

- a) makes default in carrying out the work as directed and continues in that state after a reasonable notice from the respective area **HOD** or his authorized representative:
- b) fails to comply with any of the terms & conditions of the contract or failure to comply orders after reasonable notice in writing with orders properly issued thereunder:

BHEL, May without prejudice to any other right or remedy which shall have accrued or shall accrue thereafter to BHEL CANCEL the contract as whole or in part thereof or only such work order or items of work in default from the contract. Whenever BHEL exercises the authority to cancel the contract as a whole or part under this condition, BHEL may complete the work at the contractor's risk and cost (as certified by the respective area **HOD** which is final and conclusive) being less than the contract cost, the advantage shall accrue to BHEL. If the cost exceeds the money due to the Contractor under this contract, the Contractor shall either pay the excess amount ordered by the respective area **HOD** or the same shall be recovered from the Contractor by other means. In case BHEL carries out the work or any part thereof under the provisions of the conditions the cost to be taken into account in determining the excess cost to be charged to the Contractor under this condition shall consist of the cost of the materials, hire charges of tools and plant and/or labour provided by BHEL with an addition of such percentage to cover the superintendence and establishment charges as may be decided by the respective area **HOD** whose decision shall be final and conclusive.

19. Termination of Contract on Death of Contractor:

Without prejudice to any of the rights or remedies under this contract, if the Contractor dies, or if the firm is dissolved or the company is liquidated, BHEL shall have the option of terminating the contract without compensation to the Contractor.

20. Special Power to Termination:

If at any time after the award of contract, BHEL shall for any reason whatsoever not require whole or any part of the work to be carried out the respective area **HOD** shall give notice in writing of the fact to the Contractor who shall have no claim to any payment of compensation or otherwise howsoever on account of any profit or advantage which he might have derived from the execution of the work in full but which he did not derive in consequence of the foreclosing of the work.

21. Submission and Processing Of Bills:

Payment of Bills:

1. Payment will be made after completion of work on pro-rata basis on acceptance and certification of bills by BHEL Engineer.
2. Payment shall be made against Certification by respective area **Engineer in charge**.

Contractor Signature

Contractor Seal

Name of Woks: WORKS CONTRACT FOR SHOT BLASTING AND PAINTING OF STEAM GENERATOR AT ATP, BHEL-TRICHY

Enquiry No: 9001700001 /06.01.2017

The Contractor at the end of each month shall submit a bill in triplicate detailing the various items of work done during the month supported by the requisitions issued from time to time. The Contractor shall, once in every month, submit to the respective area **HOD** separately details of their claims for the work done by them up to and including the previous month which are not covered by their contract agreement in any of the following respects:

- a) Deviation from the items provided in the contract documents.
- b) Extra items / new items of work.
- c) Items in respect of which rates have not been settled. He should in addition furnish a clear certificate to the effect that the claims submitted by him as aforesaid cover all his claims and that no further claims shall be raised by him in respect of the work done up to and including the period under report. Payment will be at the sole discretion of BHEL.

22. Along with bills, Contractors has to furnish copy of the following documents for further processing of bills:

- a) Documentary proof for payment of PF/ESI with respect to the employees engaged by the contractor with payment details relating to individual names to be submitted.
- b) Copy of payment challan of previous Month / Quarter as proof of deposit of Service Tax along with a certificate from the Contractor that tax collected from BHEL has been remitted to tax authorities.
- c) Any other relevant document which is required from time to time as per BHEL requirement.
- d) If the Contractor is not registered for any statutory obligation and not liable thereto, then a declaration shall be submitted along with offer that they are within the threshold limit.

23. Recovery from Contractor:

Whenever under the contract, any sum of money, shall be recoverable from or payable by the Contractor, the same may be deducted from or any sum then due or which at any time thereafter may become due to Contractor under the contract or under any other contract with BHEL or from his Security Deposit unless the contractor pays the claim on demand.

24. Post- Technical Audit of Work and Bills:

BHEL reserves the right to carry out the post-payment Audit and technical examination of the work and final bill including all supporting vouchers, abstracts etc., and enforce recovery of any sum becoming due as a result thereof in the manner provided in the presiding sub- paragraphs. However no such recovery shall be enforced after three years of passing the final bill.

25. Refund of Security Deposit:

The Security Deposit mentioned in condition 8 above may be refunded to the Contractor after a period of 6 months on termination or expiry of the contract provided always that the Contractor shall first have been paid the last and final bill and have rendered a "NO DEMAND CERTIFICATE".

Contractor Signature

Contractor Seal

Name of Woks: WORKS CONTRACT FOR SHOT BLASTING AND PAINTING OF STEAM GENERATOR AT ATP, BHEL-TRICHY

Enquiry No: 9001700001 /06.01.2017

26. Force Majeure Clause:

If, at any time during the continuance of this Contract the performance in whole or in part by either party of any obligations under this Contract shall be prevented or delayed by reason of any War, Hostile acts of the public enemy Civil Commotion, Epidemics, or Acts of God (Floods, Storm/Cyclone, Hurricane, Earthquake etc.) then provided notice of happening of any such event is given by either party to other within 7 days from the date of occurrence thereof neither of the parties shall by reason of such event be entitled to terminate this Contract or claim for damages against the other in respect of such non-performance or delay for such period. Performance under the contract shall be resumed as soon as practicable after such event has come to an end or ceased to exist. If the performance in whole or part of any obligation under this Contract is prevented or delayed by reason of any such event, claims for extension of time may be granted for periods considered reasonable by the respective area **HOD** at his discretion subject to prompt notification by the contractor.

27. Arbitration:

All disputes between the parties to the contract, arising out of or relating to the contract, other than those for which the decision of the respective area **HOD** or Accepting Officer or any other person is by the contract expressed to be final and conclusive shall after written notice by either party to the contract to the other party be referred to the Arbitrator, to be appointed by the GENERAL MANAGER of BHEL in his sole discretion. Unless the parties otherwise agree, such reference shall not take place until after the completion, alleged completion or abandonment of the work of the determination of the contract. The venue of Arbitration shall be such a place or places, as may be fixed by the Arbitrator in his sole discretion. The award of the Arbitrator shall be final, conclusive and binding on both parties to the contract.

28. Signing Of Contract:

Each contract document shall be signed by the Contractor with his usual signature. Contract by partnership or Hindu Joint Family firm, may be signed in the FIRM'S name by the Managing Partner or all /one of the Partners on behalf of the firm or the Karta or Manager for HUF as the case may be. Contract by a Company shall be signed with the name of the Company from a person authorised in this behalf and a Resolution or power of attorney or other satisfactory proof, showing that the person signing the Contract documents on behalf of the Company is duly authorised to do so, shall accompany the contract.

29. LIQUIDATED DAMAGES (LD)/PENALTY:

If the contractor fails to complete the service/work as per terms & conditions of the order within the delivery schedule,

- a) LD shall be levied @ 0.5 % of the order value per week of delay or part thereof subject to a maximum of 5% of the full order value.
- b) In case of any change to the order value, the LD shall be @ 0.5 % of the revised order value per week of delay or part thereof subject to a maximum of 5% of the revised order value.

Contractor Signature

Contractor Seal

Name of Woks: WORKS CONTRACT FOR SHOT BLASTING AND PAINTING OF STEAM GENERATOR AT ATP, BHEL-TRICHY

Enquiry No: 9001700001 /06.01.2017

30. Biometric Entry/Exit System for Contract Workmen:

1. The Entry/Exit of the employees engaged by contractor is to be regulated only through Biometric system.
2. The Contractor initially will be issued with a temporary gang pass for his/her employees for a period of ten days.
3. The contractor should arrange photo coverage for all his/her employees within the above stipulated time.
4. The contractor has to submit FORM-I for all his/her contract employees. All the particulars required in FORM-I are to be provided by the contractor without fail.
5. Every employee of the Contractor shall be provided with Employment Card as per Form XIV (as per Rule 76 of the Contract Labour (Central) Rules, 1971 and the contractor shall instruct its employees to carry the Employment Card as well as Entry Card without fail, while entering/exiting factory.
6. The contractor should educate his employees in registering the attendance through the system.
7. Whenever a contract employee migrates or leaves service of the contractor, the contractor has to surrender the biometric card of the particular employee to Contract Cell with immediate effect, without fail.
8. On completion of the work, the contractor has to surrender all the biometric entry cards issued to its employees immediately to the contract cell. Otherwise, an amount of Rs.100/- per card will be deducted from the final bill/security deposit of the contractor.
9. If any contract employee lose his/her entry card, the contractor shall arrange a duplicate entry card for the employee by paying an amount of Rs.100/-.
10. The Contractor is totally responsible for the biometric cards issued to his/her employee.
11. The Contractor has to indemnify BHEL for all the damages and losses caused by his/her employees.

31. Common Terms and Conditions for Works Contract relevant to Safety:

1. All the Contract employees should be trained on Safety and certified by Safety/BHEL. New employees should undergo Safety Training before take up the work, without Safety Training no contract person is allowed to do any work.
2. Use of cell phones and other mobile electronic devices (including hands-free devices) in the work spot and during the operation of a vehicle in the BHEL premises is prohibited.
3. Contract employees working on BHEL premises must wear appropriate personal protective equipment. Strict adherence to all required Personal Protective Equipment (Helmet, Safety Shoes and Goggles) are mandatory, specific PPE requirements will be based on job type or tasks performed.
4. Excessively loose-clothing, dhoti/Lungi is prohibited especially around rotating or moving equipment.

Contractor Signature

Contractor Seal

Name of Woks: WORKS CONTRACT FOR SHOT BLASTING AND PAINTING OF STEAM GENERATOR AT ATP, BHEL-TRICHY

Enquiry No: 9001700001 /06.01.2017

5. The contractors' work area should be kept clean and orderly, free of clutter and trash, so that work may proceed in a safe and orderly manner. Tools should be safely positioned during use and promptly put away when no longer required.
6. Fire-fighting, emergency shutdown devices, and life-saving equipment, should not be blocked by the contractor/employees and access to the path to this equipment should be maintained at all times.
7. Only approved equipment should be used in locations where flammable mixtures are present. A Hot Work Permit is required when open flames, or electric arcs are in the work area and while handling flammable materials.
8. Smoking is not allowed in work area.
9. BHEL operate under a comprehensive Emergency Response Plan.

Contractors should be aware of the site Emergency Response Plan and communicate that plan to all their employees.

10. It is recommended that the contractor should know & display the emergency phone numbers like Fire, Ambulance, Safety, Security etc. at their work area.
11. It is the responsibility of the contractor to understand and use the appropriate Work Permits and to verify any permit requirements at the location. Contractor must make necessary arrangements with their Representative to acquire appropriate authorization to perform those operations at the site.

32. FRAUD PREVENTION POLICY

The Bidder along with its associate / collaborators / sub – vendors / consultants / service providers shall strictly adhere to BHEL Fraud Prevention Policy displayed on BHEL website <http://www.bhel.com> and shall immediately bring to the notice of BHEL Management about fraud or suspected fraud as soon as it comes to their notice”.

Fraud Prevention policy and List of Nodal Officers shall be hosted on BHEL website, vendor portals of Units / Regions intranet.

33. SUSPENSION OF BUSINESS DEALINGS WITH SUPPLIERS / CONTRACTORS:

Penal action can be initiated on the suppliers / Contractors in line with extant ‘Guidelines for Suspension of Business Dealings with Suppliers/ Contractors. The abridged version of extant ‘Guidelines for suspension of business dealings with suppliers/ contractors’ has been uploaded on <http://www.bhel.com> on “supplier registration page”.

34. RISK PURCHASE:

a) In the event of any successful Tenderer's failure to fulfil any of the tender / Contract obligations as per Contract / Agreement, BHEL may entrust the job to alternate vendor and get it completed to meet the BHEL requirement and additional expenditure, if any, including consequential cost viz., demurrage etc., will be fully recovered from the Contractor who failed to complete the job in line with the Contract.

b) The decision of BHEL with regard to the actual losses / consequential expenditure incurred by BHEL shall be final and binding on the Contractor.

Contractor Signature

Contractor Seal

Name of Woks: WORKS CONTRACT FOR SHOT BLASTING AND PAINTING OF STEAM GENERATOR AT ATP, BHEL-TRICHY

Enquiry No: 9001700001 /06.01.2017

Name of Vendor:

PART-II (PRICE BID)

ANNEXURE-II

SN	Work Description	UOM	QTY	Rate / UOM (₹ / UOM)	Total in (₹)
1	Pre-treatment, shot blasting and painting of 700MW Steam Generator inside assembly shop at BHEL,Trichy	No.	1		
Total Value					
Service Tax @ _____ %					
Total Value Including Service Tax					

NOTES

1. Rates should be quoted in figures and words and are to be identical, if not the prices in the words will be considered as correct and the same shall be valid and binding.
2. The rate quoted shall remain firm during contract period and no extra payment will be reimbursed to the contractor by BHEL. Any increase of DA/ wages to the contract labor shall be absorbed by the contractor themselves during the period of contract.

Contractor Signature

Contractor Seal

ALL DIMENSIONS ARE IN MILLIMETERS

DRAWING NO:
3-HE-170-02703

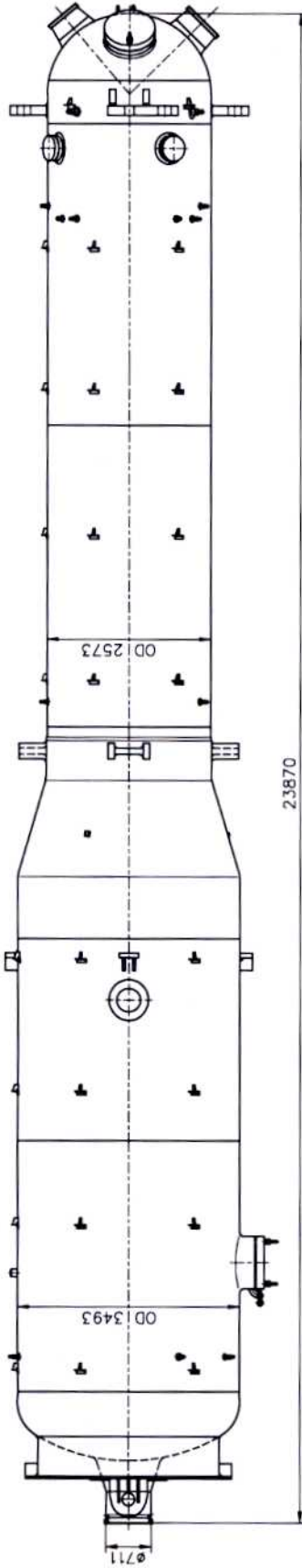

NOTES

- 01. TOTAL SURFACE AREA (OUTER SURFACE ONLY) OF 700 MWe STEAM GENERATOR IS 259 m² (INCLUDING SSA)
- 02. STEAM GENERATOR WEIGHT (INCLUDING SSA) : ~ 215 TONNES

TYPE OF PRODUCT OR NAME OF CUSTOMER/PROJECT 700 MWe KAPP-3 & 4, RAPP-7 & 8 PAINTING OF STEAM GENERATOR		NAME RAMESH KUMAR S NITHIN/BAVVARMA SUNDARAJAN A	SIGNATURE [Signature] [Signature] [Signature]	DATE 14.11.16 15.11.16 15.11.16	NO. OF VAR
Bharat Heavy Electricals Ltd UNIT: HIGH PRESSURE BOILER PLANT TIRUCHIRAPALLI - 620014		DIBK CHD APPD	WEIGHT (Kg) -	SCALE NTS	REF TO ASST / OLD DWG
DEPT NC CODE 150	GRADE OF UNTOC. DIM C/M/F	TITLE OUTER SURFACE PAINTING DETAILS OF SG	CARD CODE U 01	DRAWING NO : 3-HE-170-02703	REV
CAUTION: The information on this document is the property of BHARAT HEAVY ELECTRICALS LTD. It must not be used directly or indirectly in any way detrimental to the interest of the company.					

Size A3

014
VICE