

LIST OF TENDER DOCUMENTS HOSTED FOR 54A ARC-2023-24			
Enquiry No.652002E			Dt.02-03-2023
S.No	Section	Description	Pages
TENDER SECTIONS			
1	Section I	Notice Inviting Tender	01 to 01
2	Section II	Techno Commercial Terms and Conditions	01 to 23
3	Section III	Technical Description for RS 54A	01 to 03
4	Section IIID	List of Extra Rate Schedules for reference purpose	01 to 02
5	Section IV	General Terms & Conditions	01 to 19
6	Section-V	Drawing Numbers for RS	10 Drawings
7	Section-VI	Flow Chart for MAS	01
8	Section-VII	Not Applicable	N.A
9	Section-VIII	List of Approved Vendors for (A) procurement of Welding Consumables, Paints, Penetrant Chemicals and (B) conducting of NDT, Galvanising, Blasting and Heat Treatment	01 to 47
10	Section-IX	List of Standard QWI	01 to 01
11	Section-X	List of Quality Documents	13 Docs
12	Section-XI	BG instruction & Banker details	01 to 02
13	Section-XII	Bank Guarantee Format	01 to 04
TENDER ANNEXURES			
14	Annexure-A	Check List for Cover-I	01
15	Annexure-B	Check List for Cover-II	01
16	Annexure-C	Technical Bid Format	01
17	Annexure-D	Price Bid Format –(BoQ)	01
18	Annexure-E	Standard Commercial Terms and Conditions	01
19	Annexure-F	Eligibility Criteria - Manufacturing Facilities Available for 54A Fabrication Annexure-FH with Firm (Format will be used for Vendor Evaluation)	01 to 02
20	Annexure-G	Not applicable	NA
21	Annexure-H	Integrity Pact	01 to 05
22	Annexure-I	Affidavit	02
23	Annexure-J	Sample copy of Power of Attorney	01 to 02
24	Annexure-K	Vendor Registration Forms	01 to 14
25	Annexure -L	Not Applicable	NA

The above documents and sketches are to be downloaded from the website

**BHARAT HEAVY ELECTRICALS LIMITED**

(A Government of India Undertaking)

பாரதமிகுமின் நிறுவனம்**BOILER AUXILIARIES PLANT, Indira Gandhi Industrial Complex,
RANIPET- 632 406 (Tamil Nadu)**Ph: 04172-284030,
284158, 241170
Email:
bsmanian@bhel.in
ssvasan@bhel.in**SECTION – I****NOTICE INVITING TENDER (NIT)****(This is only a request for an offer and not a Contract)**

E Tenders are hereby invited from experienced Contractors to finalize the rate for entering into Annual Rate Contract for the year 2023-24 for Complete Manufacture of casing wall, Hopper Walls, insulator supp panels bracket assembly in X25 and other product job similar to plate panels etc, from the raw materials supplied by BHEL. Vendor scope includes collection of raw materials from BHEL (single/multiple) and delivery of finished goods to BHEL shipping. Power tool cleaning and painting is in vendor scope. In case of blast cleaning and painting to be done as per respective painting scheme, the same will be done at BHEL approved source. All extra charges are payable extra as per prevailing ARC rates. All the terms and conditions applicable for prevailing Main ARC shall be applied to this tender also.

Reverse Auction will be conducted for finalizing the rates among the technically qualified bidders

Vendors are requested to read the conflict of interest mentioned on the Clause D of Section IV before quoting the offer.

Enquiry No. & Date	652002E dt 02.03.2023
Due Date & Time for Submission Of Offer	13-03-2023 by 10.00 Hr
Date & Time for Tender Opening (Other than Price Bid)	13-03-2023 by 14.00 Hr
Place of Tender Opening	E procurement portal

This tender specifies a set of prequalification criteria defining the eligibility for the vendors to quote against a particular Rate Schedule (54A) of this tender. The Bidders are advised to go through all the enclosed Tender documents terms & conditions detailed under **Sections I to XII, Annexures- A to K**, and Rate Schedule carefully before submitting their Offer.

All the **Annexures A to K** should be filled, wherever applicable by the bidders without fail for evaluation of their offer and **all necessary / Self attested copies of the supporting documents** as required are to be uploaded in the portal. Copy of the uploaded documents are to be sent to the contracting authority.

The bid shall be submitted in three parts namely (1) EMD or Valid MSME certificate (2) Techno Commercial Bid and (3) Price Bid.

Kindly refer to the **Section-IV** – General Terms and Conditions of the tender for detailed procedure for submission of offers and details of exemption from submission of EMD for vendors registered with MSE

Kindly refer to Section-II to Section-IV for detailed scope. E Tender are hereby invited from experienced Contractors for the above scope.

Corrigendum:**Contact details / address for any clarification.**

Sr.Manager-(Contracts)

Outsourcing Department, Boiler Auxiliaries Plant
Bharat Heavy Electricals Limited, ,Ranipet-632406
Phone : 04172-284030, 284158, 284035, 241170E-Mail : bsmanian@bhel.in, ssvasan@bhel.in

	Bharat Heavy Electricals Limited (A Government of India Undertaking)		☎: 04172-284030, 284158, 284035 241170
	Boiler Auxiliaries Plant, Ranipet – 632 406		
AN ISO 9001 COMPANY	OUTSOURCING DEPARTMENT		E-Mail :bsmanian@bhel.in ssvasan@bhel.in
Enquiry No	652002E	Due Date & Time for submission of offers	10.00 Hrs by 13-03-2023
Enq-Dated	02-03-2023	Date & Time of Tender opening	14-00 Hrs by 13-03-2023
<u>SECTION II</u>			
Techno Commercial Terms & Conditions of the Annual Rate Contract 2023-24 for OS- Wall Panel Fabrication			

Scope of the enquiry is to finalize the Rate for entering into Annual Rate Contract for the requirement of 2023-24 for Complete Manufacture of casing walls, Hopper Walls, insulator panels, bracket assembly in X25 and other product job similar to plate panels etc from raw materials supplied by BHEL. Vendor scope includes collection of raw materials from BHEL (single/multiple) and delivery of finished goods to BHEL shipping. Power tool cleaning and painting is in vendor scope. In case of blast cleaning and painting to be done as per respective painting scheme, the same will be done at BHEL approved source. All extra charges are payable extra as per prevailing ARC rates. All the terms and conditions applicable for prevailing Main ARC shall be applied to this tender also.

- 1.0 Contract period for this Enquiry is One Year from the date of finalization of the contract. The Total Tonnage tentatively for this Rate Contract is 5000 MT**
- 1.1 For study and quoting of rates for Rate Schedule (**54A**), Representative Drawings, sketches, against the Rate Schedule indicated in the tender for fabrication/Assembly are made available for downloading. The sample drawings are attached in Section V.
- 1.2 Vendors are requested to have a perusal of these drawings, QWI, etc., before submitting their offer. No deviation or change from the Tender conditions will be entertained and BHEL reserves the right to reject such offers.
- 1.3 Based on the Rate contract, to be finalized, the Firms shall accept and undertake all jobs awarded to them under Rate Schedule allotted to them and execute them to the satisfaction of BHEL. Failure to comply with this requirement will be viewed seriously.
- 1.4 BHEL will conclude that the offer has been submitted by the firm, fully understanding all the requirements both explicit and implied and other conditions and accepting the same. After tender opening, contractors do not have any right to change / alter any of the conditions either partly or fully. Offers of any such firms doing so, will be rejected.
- 1.5 Vendors are requested to refer to **SECTION-IV** of this tender for (a) the applicability of EMD, (b) waiver available for EMD for MSE vendors and (c) procedure involved in submitting the offer in three parts.

2.0 FIRM RATES :

- 2.1 Please quote **FIRM** rates per MT as called for in **Price Bid** which are applicable to the firm (for Conversion Work only). The rate shall include the following and the operations called for in the conditions indicated in the tender.
- (a) The rate shall include all consumables for welding as stipulated in the drawings/QWIs /welding procedures and any indirect materials required for fabrication.(Any change in the consumable specification implemented /effected after finalizing the contract shall be reviewed and the rate shall be adjusted accordingly.)
 - (b) The rate shall be inclusive of the Transport Charges (inclusive of Toll Charges, if any) for Collection of Raw Material with allowances as specified in **Clause 3.0** and other components from Stores at BHEL, Ranipet and Dispatch of finished goods to Shipping/Stores at BHEL, Ranipet. (The rate shall be common for all vendors irrespective of the location/distance of their factory from BHEL, Ranipet). No extra transport charges shall be allowed for multiple collection and deliveries.
 - (c) Incase of transfer of raw material/semi-finished items from one vendor to another vendor, through IUWTV, the responsibility for collection of materials including the cost of transportation and handling etc. shall rest with Second Vendor (fabrication vendor dispatching the finished goods).
 - (d) The Rate shall include Transport charges (inclusive of Toll Charges, if any) for Return of balance material to BHEL, Ranipet Stores.
 - (e) The rate shall include machining of castings, forgings and fasteners which are supplied as free issue by BHEL, Ranipet.
 - (f) The rate shall include safe delivery of the finished fabrications as per QWIs and Drawings to withstand transit damages by rail/road.
 - (g) For safe delivery of export consignments as per QWIS / DRGS rates shall be quoted for the relevant extra rate schedules for payment of conversion charges shall be claimed as per remarks in the IR (**RS E72**). However in these export cases recovery on normal safe delivery charges will not be done. The extra rate schedule rate for the same shall be quoted accordingly. Supply of packing materials for such export packing will be supplied by BHEL free of cost.
 - (h) The rate shall include for protecting machined/threaded areas to avoid physical damages while handling, transportation and storage.
 - (i) Splicing of Structural, shall be done with prior permission from Outsourcing, BHEL, Ranipet.
 - (j) All Painting charges including Red Oxide painting / application of rust preventive oil as applicable shall be payable extra as per applicable extra Rate Schedule.
 - (k) Stenciling of Finished Product for Identification as per **Clause 8.5**
 - (l) The rate shall include for rectification of raw materials such as straightening, removal of bend, twist, etc. wherever necessary.
 - (m) For stainless steel fabrication, plasma cutting is not in the scope of sub-contractor. Special purpose welding, wherein materials of different specifications are to be welded (items like welding of alloy steel shafts of Fan damper etc.,) stress relieving of the same are not in the scope of sub-contractor. The rate shall be quoted considering this aspect.
 - (n) The rate shall include **LPI wherever required as per QWIs / Drgs /Sketches**. All other NDT charges like MPI/UT/RT etc payable extra as per **Clause 9.0**.
 - (o) Offering the jobs for inspection to BHEL /Customer or its authorized inspection agency is in Contractors scope and the quoted rate shall include the same.

- (p) Not Applicable
- (q) The description and PGMA's given in the Rate schedule is only indicative. Any items of similar nature shall be loaded against Rate Schedule based on the work content. For payment purpose, only Rate schedule numbers shall be considered.
- (r) Wherever Trial assembly is called for in the drawings/QWIs or by Inspection, the charges as per extra rate schedule shall be payable extra. It should be indicated in IR **subject to approval by the concerned field officer.**
- (s) Not Applicable
- (t) **Note 1:** As the charges for shot blasting, painting, heat treatment and NDT (Other than LPI) are payable extra as per extra Rate Schedule, the rate quoted **shall not include** the cost of shot blasting, painting, heat treatment and NDT.
- Note 2:** The rates to be quoted for Rate Schedule requiring the intermediate operations (including shot blasting, painting, heat treatment, NDT) **shall NOT include** the cost of TO and FRO transportation and handling of the products to the respective firms and back. Where as separate Rate Schedules are added for the same. Hence whenever intermediate operations are required to be carried out, the Charges for TO and FRO Transport is payable extra.
- Note 3:** Vendors are requested to quote the rates for (RS) in Rs. per MT (OR) as applicable for conversion, scope of work, and meeting the terms and conditions of this tender in full.
- 2.2 The rates shall be FIRM and not subject to any variation/escalation on any account during the validity of this Contract period. The rates are operative for placement of job work orders valid for **One Year from the date of finalization of the contract** on Rate Contract basis to be entered into between BHEL and the Contractor.
- 2.3 VACANT
- 2.4 VACANT
- 2.5 BHEL does not guarantee ordering of any minimum quantity or does not guarantee more share for the lowest tenderers. However, if the L1-contractors are performing well in terms of sequential dispatches and required tonnage interalia meeting the requirements laid down above, the same will be considered during loading.
- 2.6 "Notwithstanding anything to the contrary, including, but not limited to, provisions relating to extension of time and compensation/or delay, time shall be the essence of the Contract."
(The scope of Machining / fabrication, Customer approved Quality plan will be indicated in the PO as Addenda).
- 2.7 In case if the quantum of load is beyond the capacity of vendors in the opinion of BHEL or for shorter delivery requirements, BHEL reserves the right to extend/award the contract for manufacture of items covered herein to other probable new or alternative sources, without prior intimation to the contractors and BHEL's decision is final in this regard.
- 2.8 The Contractors are responsible till the Finished/Semi-finished components are safely deposited to BHEL, Ranipet. They should carefully pack, load, stack by providing wooden reapers, etc. for avoiding damage during transit and lash the consignment properly at the time of despatch so that the consignment reach the destination safely.
- 2.9 Job Work orders will be issued after entering into Rate contract with the Sub-Contractors. Discrepancy in the JWOs if any, has to be settled immediately then and there within 20 days from the date of Job Work Order.

3.0 Raw Material Issues and Accounting :

The weight indicated in GMS/DRG/ and or as per Scope indicated in the PO addendum will be the basis for accounting of raw materials issued. For billing conversion / transportation charges if any the weight indicated in GMS/Drawing only will be considered. Raw materials will normally be issued with process allowance as given below for economical operations.

Description	Invisible wastage	Working allowance	Total process allowance
Sheets	2%	1%	3%
Plates	2%	2%	4%
Structurals (Beams, Channel, Angles, Flats Rods, Pipes, Tubes, Packing etc.,)		1%	1%
** Plates of PGMAs 7xx42, 7xx44, 7xx45, 7xx46, 7xx47, 7xx49 and 7xx50. The number of permitted joints for these PGMAs are detailed in ESP:SQP:284:(Latest revision)		2%	2%

** Generally cutting plan need not be required to submit by the firm for the plates of PGMAs 7xx42, 7xx44, 7xx45, 7xx46, 7xx47, 7xx49 and 7xx50 .(clause 6.4a not applicable). However, Cutting plan for the plates of PGMAs 7xx42, 7xx44, 7xx45, 7xx46, 7xx47, 7xx49 and 7xx50 should be submitted,

- a) if the issued weight is less than the demanded weight (for the purpose of completion of job),
- b) if the Issued weight is more than the demanded weight (for the purpose of declaration of off-cut).

If the difference (between the Issued and demanded weight) is less than the off-cut norms(CI.5.0), cutting plan need not be submitted by the firm for the plates of PGMAs 7xx42, 7xx44, 7xx45, 7xx46, 7xx47, 7xx49 and 7xx50 even if the weight is more than 5MT.

For all other cases cutting plan is to be submitted before taking up the job for fabrication as per clause 6.4.

Cleared material shall be collected by the Contractors at the earliest without any delay. If BG limit becomes a constraint to issue the cleared materials, vendor shall arrange for additional BG within 2 weeks time from JWO date/material cleared date, prior to material collection.

- 3.1 The Cutting Plans should be of "Optimum only", in order to maximize the utilization of the material issued, specifically where the left out material can better be used for other jobs. The balance material, if any after Cutting Plan approval/ machining / fabrication shall be returned to our Stores at Contractor's cost. BHEL reserves the right to call for the returning of the balance material not withstanding its designation (ie. Whether Scrap / Big-size-Scrap).
- 3.2 Balance material arising out of issued quantity shall be returned by sub-contractor. However, if original issued quantity is insufficient due to the shape or size required to be cut, cutting plans may be furnished for BHEL approval WITHIN ONE WEEK OF DRAWAL of Raw materials(However for Spiral Casing, Suction chamber and Silencer required for FAN Assy the Cutting Plan to be submitted within 15 days). Any off cut available from the original issue should be returned to us as per our approved cutting plan. Wherever the materials are supplied by BHEL for mockup test, welders qualification test, Etc., the material is to be treated as scrap on weight basis and material accounting to be settled accordingly.
- 3.3 Wherever firm comes across receipt of excess material due to the error in GMS/Drawings that is to be brought to the notice of AGM/OS immediately. Since material is issued on weight basis, any excess material received on account of section weight variation or otherwise, the same is the property of BHEL, not withstanding the status of MAS. Such information shall be declared by the supplier to BHEL immediately.
- 3.4 Inventory statement has to be submitted every month by the firm for the free issued materials. If the Fabricator fails to produce or properly account the materials so issued, BHEL,

Ranipet will have the right to take further action as deemed fit including recovery of the value of the materials along with the respective administrative charges and statutory levies from the running bills of the Fabricator / temporary suspension of load / termination of contract / de-listing.

- 3.5 Any act of Contractor resulting in dishonest misappropriation or conversion of the materials so issued for his own use shall constitute the offence of Criminal Breach of Trust under Indian Penal Code and /or such other offences under any other provisions of law and the Contractee shall have every right to proceed against the Contractor under Criminal Law in order to ensure proper punishment to such perpetrator/s for the said offence/s. In such cases, BHEL shall take all necessary steps to recover the material available with those firms.
- 3.6 Movement of BHEL materials from Contractor's premises to any other Firm(s), if necessary, for the purpose of production related work shall be documented properly, signed by the sender & receiver and the same to be authenticated by the concerned OS official, otherwise such materials will be treated as shortage by BHEL Accounts.
- 3.7 Protecting the material issued by BHEL under safe custody until completing the delivery as required is vendor's responsibility.

4.0 Working Allowance:

After scrutinizing the design documents, whenever additional allowance is required due to more volume of machining process, the process planner is authorized to increase/decrease the **working** allowance. Cutting plan must be submitted by the vendor for such cases. This is done to avoid unnecessary raise of supplementary MIV. Whenever the demand weight is **low** and less than off-cut weight, the process planner is entitled for giving net weight credit (NWC) to the firm, **instead of raising MIV**.

- 4.1 Wherever shearing and punching, raisal of supplementary MIV are involved, No process allowance is applicable. However Process allowance is applicable for profile and zigzag cutting process. No invisible wastage will be allowed for the following:
Sheet 2 mm in Screen Sheets 7XX 08 PGMA's, Stainless steel material, dia 8mm bright bar for EE holder, Retainers processed by Punching, haste alloy material in Damper & Gate Seals, Shock Bar Plate of RS No :160 **and perforated sheets 2mm used in FAN Silencers**.
- 4.2 For HASTE ALLOY MATERIALS the weights of component as per drawing will hold good for accounting of raw materials. Raw material will be issued in running meter for haste alloy material and since coils are in running meter, there will be no process allowance for all shearing operations. The Carbon steel (CS) portion of Haste alloy welded seals must be painted with one coat of synthetic enamel paint or as per specific requirement of the customer, the painting charges will be payable extra as per extra rate schedule and all seals must be packed as per BHEL'S requirement. The contractor will have to return all the balance material of haste alloy strip, in issued width, to BHEL/Ranipet Stores at contractor's cost.

5.0 Scrap / OFF-Cut Norms :

Sl	Description	Scrap Size (mm)	Off Cut Size (mm)
1	CS/AS Sheets & Plates	Below 500 X 250	500 X 250 & above
2	Rolled Sections Including Structural(other than CS/AS rods upto dia 40mm/tubes/pipes): Length	Below 1000	1000 & above
3	CS/AS Rods greater than dia 40mm, RHS, SHS, Tubes and Pipes: Length	Below 500	500 & above

4	SS Non Ferrous Sheets & Plates	Below 500 x 250	500 x 250 & above
5	SS Non Ferrous Structural, rods, tubes, pipes: Length	Below 250	250 & above
6	Haste Alloy Length	Below 250	250 & above
7	Big Size scrap Length x Breadth CS/AS	(2500 & above)X (150-249)	-----
8	WSTE/NAXTRA Materials.	Below 500 x 250 dia 350	Below 500 x 250 & above Dia 350 & above

The issue of various wool, CAF Joints, Asbestos rope etc. will be as per required Quantity. Excess material issued if any will be treated as scrap in view of practical problems (Re-Packing, verification, receipt, accounting, storage etc.)

- a) All Off-Cuts (Ferrous, Non-Ferrous, SS etc.) are to be returned to BHEL stores with RSV at contractors' cost.
- b) Returning of Off-Cuts/Prime material to BHEL is mandatory. Failure to return the materials (prime material/off-cut) will entail recovery of the cost of materials along with GST duty, & other Statutory levies as applicable plus departmental/administrative charges fixed from time-to-time **Cl.6.7** from any of the running bills of the supplier/other means of recovery available for the non-returned quantum. The non returned quantum of material (Prime/off-cut) will be as per FMAS approved by BHEL.
- c) Wherever the materials are supplied by BHEL for mock-up test, welders qualification test etc. (except for Nitriding & Case Hardening), the same will be treated as scrap as classified above.

5.1 All scraps (Ferrous, Non-ferrous, SS, CS/AS, WSTE etc.,) including Turnings and borings need not be returned to BHEL. Contractors can dispose the above scrap, on completion of Final-Material-Accounting for the respective IP. Necessary cost shall be recovered along with ED, Sales Tax and any other statutory levies if applicable.

5.2 The Rate Schedules for recovery of different types of scraps are as follows:

Sl.No.	Description	Rate Schedule
01	Recovery rate for Scrap of CS/ AS, Asbestos, wool, CAF etc.,	E41
02	Big size scrap (CS/AS sheets/plates)	E42
03	Recovery Rate for Scrap of Stainless Steel (NON Magnetic), NON -Ferrous Metals.	E43
04	Recovery Rate for Turnings and Borings scrap of CS/AS	E44
05	Recovery Rate for Turnings and Borings scrap of SS Non magnetic , Non Ferrous	E45
06	Recovery Rate for Turnings and Borings Scrap of Stainless Steel- Magnetic	E46
07	Recovery Rate for Stainless Steel magnetic scrap	E73

As far as the Recovery RS u/E44, E45, E46 prevailing rates shall apply for this contract also.

5.3 For machining/drilling jobs, the Turning & Boring scrap generated shall be accounted and recovery will be made as per Scrap norms as given in **Cl. 5.0 , 5.1 and 5.2**. For SS and nonferrous 100% of T&B scrap will be recovered.

6.0 Disposal of Scrap and Return/Accounting of Balance Materials:

Contractors who wish to dispose off the scrap from their end are permitted to do so subject to the following conditions:

- (a) They should possess GST Registration under GST Act and GSTIN NO. under GST Law. Copies of the same shall be furnished to Manager /Finance/BHEL, Ranipet.

- (b) The recovery for the above all categories of scrap will be as per the Final Material Accounting Statement (FMAS) approved by BHEL and as per the ARC Rates signed by BHEL and Contractors.
 - (c) However GST applicable for all the scrap disposed off at the Contractor's end will be to their account. BHEL will not reimburse this amount. Necessary GST formalities are to be followed by the Contractor.
 - (d) GST on scrap will be recovered as applicable
 - (d) Scraps shall be disposed off only after submission and approval of Final Material Accounting Statement (FMAS) by BHEL
- 6.1 Wherever attested materials are issued, the balance materials are to be returned only in the attested condition. Otherwise **Cl. 6.7** below will be applicable.
- 6.2** The materials rejected as PDO due to reasons attributable to vendors like (a). Faulty workmanship, (b). Improper storage of raw material issued by BHEL (c) improper handling (d) improper packing etc.. Will entail recovery at prime material's cost as per **Cl. 6.7**.
- 6.3 The materials rejected due to other than reasons **u/cl.6.2** shall be returned to BHEL, Ranipet Stores failing which recovery will be made as per **Cl. 6.7**.
- 6.4 The material supplied by BHEL, Ranipet shall properly be utilized as per the Scope in Contract/drawings/QWIs in job work order to meet the design and quality requirements of the product. Hence economic cutting plans are required to be submitted by the Contractor for approval in the following cases:
- (a) For sheets, plates & structural where the original issued / transferred(IUTV) quantity is more than 5 MT.
 - (b) Whenever the issued quantity is insufficient owing to shape or size.
 - (c) All stainless steel/Haste alloy/Non-ferrous items.
 - (d) Excess issue in weight against demanded quantity wherein the excess quantum is more than off-cut norms (**vide Cl. 5.0**).
 - (e) For items like flanges, rings, cover plates, etc. where demanded weight is in excess of net weight with higher rate of process allowance. (However cutting plans need not be submitted where the collected material weight and net weight difference which is less than off-cut weight). In any case, cutting plan need to be submitted for issue weight 5 MT and above.
- 6.5 However, in working out such economic cutting plans, it is to be ensured that the details furnished by the contractor are as per current GMS, Job works order & IOM and meets the requirements as prescribed in QWIs shall have to be adhered to. After the approval of the cutting plans, any off-cut, available from the issues made either in original or in supplementary shall be returned to the BHEL, Ranipet Stores at the Contractor's cost. The cutting plans as approved by the Outsourcing, BHEL, Ranipet shall be kept at the Contractor's premises and to be made available as and when demanded by the BHEL Officials or their representatives. It should also be ensured that the jobs shall be as per the approved cutting plans. All returnable materials (prime/off-cut) as per Cutting Plan approval covering letter shall be returned to BHEL, Ranipet Stores immediately without waiting for the W.O./P.O completion to avoid any payment hold and subsequent recovery.
- 6.6 Whenever machining / fabrications are done without proper approved cutting plans, any loss of material arising due to the same will be recovered at prime materials cost including the process allowance indicated in **CL. 3.0 & 4.0** plus Departmental / Administrative charges fixed from time to time (**vide Cl. 6.7.**). In addition, statutory taxes, duties and levies etc., applicable will also be recovered from the Contractor and also other actions as deemed fit will

be taken and no claim for refund will be admitted by BHEL, Ranipet. BHEL's approved cutting plan is final.

- 6.7 Failure to return the materials (prime/off-cut) will entail recovery of the value of the materials plus departmental/administrative charges fixed from time to time. Currently the departmental/administrative charges are 25% for indigenous material and 50% for imported materials on the material value. In addition, statutory taxes, duties & levies as applicable will also be recovered and no claim for refund will be admitted by BHEL, Ranipet. The rate of departmental and administrative charges as applicable from time to time irrespective of the date of failure will be applicable. Besides penal interest will be levied on the material value, for the period starting from date of issue of material.
- 6.8 Where an increased allowance over the process allowance as stated in **CL. 3.0 & 4.0** is necessary, the same will be issued after scrutinizing and approval of cutting plans.
- 6.9 For the purpose of material accounting after completion of a particular WO, BHEL/OS department will issue a preliminary material accounting statement thro' E-mail, the next day of completion.
- (a) The Contractor shall respond within 7 days of receipt of Preliminary MAS, Either by Accepting the Pre-MAS OR submit their own MAS (Contractor/Firm-MAS) in the case if the Pre-MAS is not in line with the requirement.
- (b) Any discrepancy Like weight correction, DU correction, variation in off-cut /scrap quantum etc., as indicated in Pre-MAS will have to be reconciled with the Material Accounting section with necessary proof of documents within a week from the date of issue of Pre-MAS. If reconciliation is not done within a week, it will be treated that Pre-MAS is correct in all respects
- (c) If the Pre-MAS is accepted by the Contractor, BHEL will prepare, within 7 days, the Final-MAS.
- (d) In case if Pre-MAS is not accepted by the Contractor, the Contractor/Firm-MAS submitted, if any, by the Contractor will be considered and if no such Contractor/Firm-MAS is submitted also, BHEL will prepare a Provisional-MAS and send through email, within a week.
- (e) If the material (CS/AS) to be recovered as per BHEL MAS working is within plus or minus 10 Kgs with respect to Contractor/Firm-MAS, then final MAS will be released with out Pre-MAS acceptance.
- (f) For Deleted /Diverted Job Work orders, Final material accounting should be settled within 14 days time, after deletion/diversion. Otherwise, BHEL will prepare Final-MAS on completion of 14 days of IOM date on suo-motto basis. For exceptional cases with reasons attributable to BHEL, a further relaxation of 1 week will be given on the certification of respective field officers (Please Refer **Section VI** on work-flow for details).
- (g) The response if any received from the Contractor, will be studied and considered and Final MAS will be prepared. In case if no response is received, the provisional MAS will be treated as 'Final' MAS and accordingly, Final material accounting statement (FMAS) will be issued. BHEL will prepare the FINAL MAS within 30 days of DC control.
- (h) After completion/cancellation of (Issue Position) IP the Contractor has to submit Contractor/Firm MAS comprising material issue cum working details, contract and receipt statement as per the format specified by BHEL for entire IP within 7 days from the date of delivery of last despatch or on date of submission of 100% invoice whichever date falls earlier of the respective IP. Further to, Contractor should certify the submission of bills with 4 (5)(a) Challan's duly signed with seal in part II including completion of all transactions like cutting plan approvals, return of BHEL Material on RSV, IUWTV controls and submit along with MAS.

- (i) Once the IP is closed as mentioned above no re-opening of IP except recovery from running bills will be entertained.
- (j) The contractor shall be bound by the accounts, statements acknowledgement of materials, BHEL material issue documents, receipts etc., wherever signed by their representative.
- 6.10 Return of any balance material to our applicable Stores-Ward at BHEL / Ranipet immediately after cutting plan approval.
- 6.11 Recovery towards non-return of balance material as per FMAS will be done as per Contract norms along with statutory taxes, duties & levies as applicable from any one of the running bills OR from other means of recovery available Hence, any correction after the issue of FMAS, the job work order will be treated as closed in all respects thereby any requests towards refund of recovery, if any, will not be entertained.
- 6.12 Wherever MAS not required to be submitted, in case if the material (CS/AS) to be recovered as per our MAS is within (+) or (-) 10 Kg and there is no material collection is involved, BHEL will prepare Final-MAS on suo-motto basis and Recover/Net-weight credit will be provided accordingly.
- 6.13 Please note that the Contractor is responsible for prompt material accounting and settlement of outstanding dues towards non-return of balance material. Repeated occurrence of inordinate delay in settling the material accounting / outstanding dues will entail BHEL the right to terminate the contract forthwith or to impose temporary suspension on further loading at the discretion of BHEL, Ranipet. Also in case of non-return of material or non-submission of material accounting statement, BHEL reserves the right to en-cash the Bank Guarantee / Fixed Deposit Receipt submitted by the Contractor and initiate legal action against the Contractor against this contract OR any other contract, in addition to the other means of recovery from contractor, available with BHEL.
- 6.14 The raw material issued to the Contractor as free issue shall remain the property of BHEL, Ranipet. The Contractor shall use the above material only for the execution of BHEL'S contract/addenda and for no other purpose whatsoever. The Contractor shall be responsible for the full value thereof to be assessed by BHEL, Ranipet whose decision shall be binding on the Contractor, The Contractor shall be liable for the loss or damage to such property while such property is in the possession or under the control of the Contractor, their employees, workmen, representatives or agents or any other person connected with the Contractor. The Contractor should execute an agreement in **Rs. 100/-** non- judicial stamp paper and maintain the secrecy of the design, know how of BHEL products.
- 6.15 All the materials of BHEL, Ranipet shall under no circumstance be hypothecated/leased/liened /encumbered to any bank or to any lending Institution or to any party whomsoever. It should not also be shown as the Contractor's assets in any of the statements of the Contractor to any party.
- 6.16 The Contractor shall, whenever required, produce the materials supplied as free issue by BHEL, Ranipet in the form of raw material, semi-finished or fully completed boiler components to BHEL officials visiting the Contractor's unit for verification purposes. If the Contractor fails to produce or properly account the material so issued, BHEL, Ranipet will have the right to take further action as deemed fit including recovery of the value of materials along with the respective administrative charges and statutory levies from the running bills of the Contractor (with BHEL, Ranipet and with other Units of BHEL) and also any or all of the actions such as, Suspension of business dealing, temporary suspension of loading, termination of Contract, holding the payment due etc., Similarly for the claim made by any units of BHEL (on account

- of such vendor) to the BHEL, Ranipet, the Bank Guarantee submitted to BHEL, Ranipet will be encashed.
- 6.17 As and when required/applicable, BHEL, Ranipet will transfer(or advice for returning u/RSV) the balance material available including scrap size available for which PO/Issue Position(IP) is not closed, from one Contractor to the other contractor/other IP of the same contractor. For this, necessary credit will be given in material accounting, the material transfer emanating from Outsourcing, BHEL, Ranipet is to be honored by the Contractor within 15days or otherwise recovery will be made at the prime material cost., Any difficulty for effecting such transfer shall be brought to the knowledge of OS/ BHEL, Ranipet officials immediately.
- 6.18 The Contractor is responsible for submission of CLEAR material accounting statement (MAS) i.e. ensure that all transactions are completed (including IUWTV/RSV, supplementary material collection, submission of cutting plan, etc.) within 7days from the date of completion of work order & failing, without prejudice to other rights under Contractor, law or otherwise, which MAS will be closed suo motto basis and recovery of the scrap/off-cut will be effected after adjusting of balance payment due to the Contractor from any of the running bills. Delay in settling the material accounting will entail BHEL the right to terminate the contract forthwith or to impose a temporary suspension on further loading at the discretion of BHEL, Ranipet.
- 6.19 For any IP if the total requirement of carbon steel plates of 5mm to 10mm thick is 20 kgs or less, Contractors have to use the required material from the balance material of other work orders. However, these quantities will be adjusted as Net Weight Credit (NWC) during material accounting.
- 6.20 Raw materials will be loaded by BHEL, Ranipet either in lorries/trailers/ bullock carts and can be overseen by Contractor's representative at BHEL Stores / Shop. Shortage or variation in quantity, size and weight shall not be accepted once the material leaves BHEL, Ranipet Stores. Raw materials will be issued by BHEL, Ranipet, only after the receipt of necessary Bank Guarantee as per **Cl.20.0 and 21.0.**
- 6.21 Where an entity (whether a proprietorship, partnership, company, Hindus Undivided Family or otherwise) commits a default or breaches the Contract and the proprietor/ partner/ director/ member of such entity is also a proprietor/ partner/ director/ member of another entity that is registered with BHEL (in Ranipet or any other unit of BHEL), BHEL shall have the right to recover losses due to the default or breach, whether direct, indirect or consequential, either from the defaulting/ breaching entity or the other said entity or both. Such right shall also include the right to encash any security (in any form such as but not limited to bank guarantee, demand draft, FDR, etc.) furnished by either or both entities. Without limiting the applicability of the foregoing, it shall not be a defence to the other said entity for enforcement of such a right that:
- (a) Both entities are legally distinct/ separate entities, or
- (b) The management of the entity/ partners/ directors/ members of such other entity were not aware that the proprietor/ partner/ director/ member of the defaulting/ breaching entity was also a proprietor/ partner/ director/ member of the other said entity.
- 6.22 The Contractor shall be bound by the accounts, statements acknowledgement of materials, receipts etc., wherever signed by their representatives.
- 6.23 The value of the materials and statutory levies towards non-return of off-cut/scrap wherever applicable will be calculated at the rate prevailing as on the date of accounting and demand thereof by BHEL irrespective of the date of failure for return of the off-cut/scrap by the Contractor.
- 6.24** For the Contractors who come under **Cl.28.0(B)**, the scrap arising out of the issued raw material shall be disposed off as per **Cl.6.0.**

- 7.0 Surface Preparation:** Surface preparation to a cleanliness level of Swedish Standard Protective Coating (SSPC) Sa 2 ½ (near white metal finish) i.e " Removal of loose mill scale and loose paint, to the degree specified, by the impact of abrasive blast propelled through nozzles or by centrifugal wheels. Near white blasted surface shall be free of all visible oil, grease, dirt, mill scale, rust, paint, oxides, corrosion products, and other foreign matter, except for staining limited to not more than 5% of the surface area. Such staining may consist of light shadows, slight streaks or minor discoloration caused by stains of rust mill scale, or stains of previously applied paint. The surface preparation to Sa 2 ½ (near white metal finish) and immediate painting is to be done, only at the BHEL approved sources allocated by BHEL / with the approval of BHEL in case of Self blasting and painting.
- 8.0 PAINTING:** All painting works shall be part of main fabricators responsibility, including cost of paints. However extra rates are payable as per extra rate schedules (listed under Heading "Charges for Painting" in **Section-III-D** titled "List of Extra Rate Schedules"). The fabricators are advised to quote their rates for each Rate Schedule per Sq.meter basis. ALL PAINTING CHARGES (PRIME/FINISH/SPECIAL PAINTS ETC) PAYABLE EXTRA AS PER EXTRA RATE SCHEDULES. The paints shall be procured from BHEL-Approved paint manufacturers list given in **Section-VIII**
- 8.1 The finished/Semi-finished components shall be cleaned by power operated wire brush and painted with primer as per QP/ QWIs/ CIS purchased from our approved paint manufacturer's list hosted with this tender as **Section VIII**.
- 8.2 For all painting over and above the Primer painting whenever required, the finish paint as per applicable QWIs/CIS shall be applied.
- 8.3 For all painting including primer painting , the charges shall be payable as per applicable extra rate schedule.
- 8.4 For painting of Extra Coating thickness with reference to coating thickness mentioned in the extra rate schedule description pro-rata charges shall be payable extra based on IOM issued by BHEL/OS.
- 8.5 Unless stated specifically Foundation material, columns up to zero level need not be painted with red oxide. Further, the fabricated semi-finished components shall be legibly stenciled with the Project Name, Work Order Number, DU Number , quantity, weight, Sub-contractor's code Number, match mark no., etc., for identification and dispatched as may be advised.
- 8.6 Sub-contractor code number alone shall be punched using ½ inch letter punch and bordered suitably for easy identification. All the identification marks shall be coated with an overcoat of transparent varnish to protect against weather.
- 8.7 Application of one coat of the specified primer painting is to be done immediately after Blast cleaning as per the stipulated dry film thickness (DFT) normally varies from 35 microns to 100 microns.
- 8.8 Machined surfaces and Retainers shall be applied with rust preventive oil in place of red oxide.
- 8.9 Whenever blasting by Grit/shot for surface preparation is to be done, the applicable ARC rates will be payable extra. The allied To & Fro Transport charges are also payable extra as per the respective extra Rate Schedule and a self certified declaration from the fabricator (certified by Field officer) is to be enclosed by the concerned fabricator , along with their respective invoices to the effect that the components are blasted not in their works but else where .

8.10 Whenever galvanizing is to be done the charges for Galvanising and The allied To & Fro Transport charges are also payable extra as per the respective extra Rate Schedule. Whenever the galvanizing is done at Galvanizing source, who signed Annual Rate Contract **(ref. Section-VIII)** exclusively for galvanizing rate schedules, the charges for galvanizing will be directly paid to Galvanizing supplier against their Job Work order and respective invoices.

9.0 UT/RT/HT/SR: The Ultrasonic Testing, Radiographic Testing, Heat Treatment and Stress Relieving as called for in the drawing/QWI/JWO are to be carried out by the fabricator, through the approved agency of BHEL. Approved agencies are as per **Section–VIII**. For Charges for carrying out of the above operation is payable extra as per the extra rate schedules and allied To and Fro Transport charges are also payable extra as per the respective extra Rate Schedules. In case there is no approved agency near vendor's works, vendor may locate suitable agency for RT, MPI, LPI, SR and UT and get them approved by BHEL before commencing the job. For such approval, the agency has to fill up relevant Vendor Registration Form available with BHEL.

10.0 EXTRA RATES FOR CONVERSION:

Rates for the special requirements like Special Painting, Heat Treatment, Transport Cost for Intermittent Operations etc. other than RS specified in this tender are to be paid as per prevailing ARC rates,

Rates as per extra rate schedules shall be payable extra as per remarks in the IR. The extra Rate Schedules are applicable for all the contractors. The rate finalized for RS-NO. 185A for "Surface preparation equal to shot blasting " will also be operated under Extra Rate Schedule-E08.

Any other extra work not covered under extra RS, but incidental to the completion of fabrication job till handing over to BHEL, shall be deemed to be part of the main fabrication rates.

10.1 **Conversion of Sections:** In a situation where flats of various sections called for in the assembly are not available, plates will be issued for conversion into flats. Also, you may be required to convert channels/angles to another size for which extra charges are payable (as certified by OS officials based on certification made in the IR) for the net weight of finished section as per the Extra Rate Schedules.

10.2 whenever substitution are offered which involves higher / lower work content, the charges shall be paid extra/ recovered as the case may be.

10.3 **For Additional Joints:** In case any additional joints **made over and above the drawing /QWI requirements** with prior approval of BHEL owing to the non-availability of required size of raw materials is **applicable** only for the following, rate schedules. **Rates for extra joints includes cost of LPI/MPI charges also.**

The Sub contractor can claim extra rate as per applicable extra rate schedules based on IR and certification from OS expediting officials..

10.4 For all jobs wherever optional joints are mentioned in the drawing, no extra rates are permissible. For Ducts no extra rates are permissible for joints.

10.5 The fabricator can claim extra rate as per applicable extra rate schedules for any additional joints put up by fabricators during fabrication, over and above called for in the Drawings and based on IR and certification from OS officials for applicability of extra rate for additional joint enclosed along with fabricators invoice.

- 10.6 Extra rate for Radiography, UT and for MPI alone are applicable. However, **NO extra rate** is allowed for LPI. Rates as per extra rate schedules shall be payable extra for Grit/ shot blasting, painting (all type) of painting, HT & NDT charges (Other than LPI) etc.,
- 11.0 TRANSPORT CHARGES :** Tender calls for the offers on F.O.R-Destination basis (ie. Freight charges inclusive in the quoted price), hence No Transport Charges payable extra for the Raw Materials / Components collected from BHEL and return of finished items vice-versa.
- 11.1 Incase of transfer of raw material/semi-finished items from one vendor to another vendor, through IUWTV, the responsibility for collection of materials including the cost of transportation and handling etc.. shall wrest with Second Vendor (fabrication vendor dispatching the finished goods).
- 11.2 No extra charges towards transport will be allowed for multiple collection & deliveries (due to various reasons including 1. Part-qty available for collection, 2. Part-qty required to be delivered by vendor.
- 11.3 **Additional Transport Charges:** Transport Charges incurred by the vendor for any special intermittent operations other than specified in the Rate Schedules or any additional movement requested by BHEL officials in writing, the transport charges payable extra as per the Extra Rate Schedules available in the contract.
- 11.4 For return of PDO materials thro RSV (PDO other than reasons **u/cl.6.2** like issue of faulty materials, non suitable materials, any drawing revision etc), TO & FRO transport charges as per applicable extra rate schedule shall be payable extra.
- 11.5 The Rate payable against the Extra Rate Schedules are inclusive of Toll charges, if any.
- 12.0 Recovery of Transport Charges:** If the materials are delivered/collected by BHEL/BHEL approved transport contractor when the scope of transport is with vendor, the freight charges incurred by BHEL will be recovered from the vendors.
- 12.1 If Purchase Order is placed with delivery destination other than BHEL-Ranipet, the respective transport charges for delivering the finished job is to BHEL's Account and the amount of transport charges (already included in the rates finalized for the RS) for delivering to BHEL-Ranipet is deductible.
- 12.2 **Dispatch of finished goods Direct to Site (DTS):** Wherever necessary, BHEL may advise fabricators to dispatch finished goods directly to site with transport charges to BHEL's Account. The scope includes loading of finished products on truck for dispatch to respective BHEL-site offices/BHEL's-Customer. In such cases the cost of transportation from Contractor's works to BHEL,Ranipet, not incurred by the vendor shall be recovered from the vendors.
- For all the above, the recovery of Transport Charges will be made as per Extra RS E07X, E07Y and E07Z which is to be finalized in OS MAIN ARC tender.*
- 13.0 PAYMENT FOR EXTRA CHARGES :** 100% Payment will be made for extra charges against Invoice supported by acknowledged Delivery Chelan and Inspection Report (IR) issued by BHEL Inspector/agency. **The payment of extra charges will be made only to the Extra RS Nos, UNIT, Qty mentioned in the IR duly concurred by BHEL Field Officers.**
- 14.0 SAFE DELIVERY:** The Contractor shall do at his cost the necessary packing for easy & safe handling and transportation as per BHEL drawing wherever specific packing arrangements are applicable and normal packing for the other items required for transit by rail/road transport wherever necessary.
- 15.0 TERMS OF DELIVERY:** The price should be on "F.O.R- BHEL Stores/Shipping, Ranipet" basis only (Inclusive of packing, forwarding and freight charges).

The finished machining / fabrications on acceptance by BHEL, Ranipet inspector or by their authorized inspection agency shall be delivered to BHEL, Ranipet Stores / Shipping or to BHEL Sites / Customer as the case may be immediately.

16.0 TECHNICAL REQUIREMENTS :

- 16.1 The machining / fabrications shall strictly confirm to the dimensions and tolerances indicated in the drawings/QWI. Care must be taken to adhere strictly to the NOTES given in the drawings/Contract. It should be ensured that actual dimensions, and deviations if any, are recorded properly in the D.R. books and preserved at least for 5 years. The same shall be made available to BHEL Officials or their authorized agencies.
- 16.2 Any other work carried out outside the requirements of drawings/QWIs shall have the prior approval of the competent authority of Outsourcing / BHEL, Ranipet.
- 16.3 Adequate facilities like welding equipments, baking oven, handling facilities and measuring instruments as called for, must be available duly calibrated and kept with the Contractor for the manufacture of boiler components. All the above basic machining / fabrication facilities/equipments must be under working condition and the same be made available for verification by the BHEL officials or their authorized agencies whenever they are called for.

The instrument/gauges are to be calibrated periodically as follows:

Sl.No.	Type	Periodicity
01	Measuring instruments / gauges	One year
02	Limit Gauges (Eg. Plug/ring)	One year
03	Temperature , Pressure gauges	6 months
04	Measuring Steel tape	Once

Calibration status shall be displayed at the Contractors works in a conspicuous location. Calibration can be performed either at BHEL or at any Govt. approved labs traceable to National Standards.

- 16.4 For Rate Schedule, the manufacturing, handling and testing facilities requirement as specified by BHEL from time to time shall be available with the Contractor.
- 16.5 Only the right kind of matching welding electrodes shall be used as called for in the drawings/QWIs after necessary baking and pre-heating mentioned in QWI. Welding electrodes shall be sourced only from approved vendors as per **Section-VIII**. The electrodes shall be suitably baked and preheated wherever applicable before use in addition to the general precautions that may be applicable for all electrodes in storing etc...
- 16.6 Welding to be carried out by Qualified Welders and as per BHEL Approved Welding Procedure Specification (WPS). Necessary raw material for conducting the pre-production test will be supplied by BHEL as supplementary materials. The welder qualification and welding procedure will be done by QC, BHEL or by their authorized agency.
- 16.7 All welds of Submerged Arc Welded components shall be carried out by certified welders and shall be dye-checked for root and by MPI for final welding.

17.0 INSPECTION:

- 17.1 Inspection of fabrications/Machinings (conversion work) shall be by BHEL Quality control department and/or by the customers and/or by an agency or persons authorized by BHEL, Ranipet at the Contractor's works including Self Inspection firms. Selected firms shall be approved by competent authority authorizing self inspection. The concerned Engineer/supervisor/Authorized Official of the firm authorized by the firm to carry out all

Inspection activities and their authority/activities shall be on par with any other Inspection agency approved by BHEL (like TUV/IRS/INTERTEK etc.,). All facilities and equipments, calibrated instruments like tapes, thread checking gauges upto M20, and bore dial gauges and bits up to 100 mm. and standard gauges required for inspection shall be provided by the Contractor free of cost.

- 17.2 BHEL representatives/authorized agencies will have free access to the Contractor's works at any time during the execution of job work orders as well as for verification of requisite documents/materials. (The requirement of Customer approved quality plan will be indicated in the PO/Addenda).
- 17.3 The semi-finished components are deemed to have been accepted as ready for delivery only after IR is released by the Inspecting Agency.
- 17.4 Statutory inspection requirements such as IBR/External Inspection agency requirements if any, are to be met by the Contractor.
- 17.5 The paint quality will be checked by BHEL Ranipet at regular intervals. Samples will be collected from vendor works and will be tested at BHEL to ensure quality as per relevant standards. In case of discrepancy in meeting our specification the job may be rejected/vendor may be put under suspension of business. **The vendor shall ensure mentioning of the details of paint applied, no of coats, coating thickness on the respective IR of the job.**

18.0 PAYMENTS :

- 18.1 Payment will be made for IP wise 100% for the supplies made against submission of Vendor invoices in duplicate to Finance section furnishing the job work order Sl. No., W.O., IR & DC No. along with IR, giving details of work carried out as per Extra Rate Schedule applicable, if any supported by
- (a) Stores Receipt Voucher in case of Stock Work Order items.
 - (b) Delivery challan acknowledged by BHEL Stores/Shipping.
 - (c) Inspection Report (IR)
 - (d) finished goods are dispatched directly to site (DTS) from fabricators works as per BHEL instructions, necessary formalities to be followed as per BHEL conditions stipulated from time to time . Also in such DTS cases, the documents like copy of DC, Lorry Way Bill etc shall be submitted along with their invoices for payment purposes.
- 18.2 The amount due to BHEL, Ranipet, if any, will also be recovered from the Contractor's running bills. No request for the refund of penalty/recovery will be entertained after final material accounting is done. Payment will be made only through 'Electronic Fund transfer/RTGS Transfer'. Acceptance for the same may be submitted in the prescribed format if not done already.
- 18.3 Owing to the substitution, if the raw material weight changes over and above (+) or (-) 5%, the conversion cost for the difference in weight shall be paid/recovered prior to the issue of FMAS. Since payment is made for notional design weight, any correction issued for the design weight after processing the original invoice, Contractor is entitled to raise another invoice for the difference in weight without any other supporting document except the copy of the original invoice.
- 18.4 Payment will be restricted to two bills per Work Order or Job Work Order Sl. No. only. Excise Duty as applicable for Contractor's covered under **clause 28.0**, can be claimed along with documents / certificates mentioned therein. However, one more bill per month against any one of the pending Work Orders will also be permitted as a special case and this should have the prior approval by competent authority.

- 18.5 The Contractor shall ensure that ALL claims including extra charges, if any, as per **Cl. 4.0** are made against the particular work order before the issue of Final-MAS since BHEL will not be able to reopen the case after issue of Final-MAS.
- 18.6 The payment shall be subject to the deduction of any amount for which the fabricator is liable indirectly under this contract or any other contract of the fabricator or any other fabricator's contract where the proprietor / any of the partners / directors of the present fabricator is / are proprietor/director/s/partner/s, in respect of which BHEL / Ranipet is a contractee.
- 18.7 Request for delivery extension is to be made if there is a valid reason, in the format for that particular job work order Sl. No., failing which liquidated damages will automatically be levied as per **Cl. 23.0**. No request for extension/refund of penalty will be entertained there after.
- 18.8 Payment will be made in about 45 days after receipt of valid invoices raised in accordance with **Cl. 18.1** and supported by full set of necessary documents at Accounts Department. No interest shall be payable by BHEL on any money due to the Contractor by BHEL.
- 18.9 For the purpose of payment, only the unit rates are to be considered based on the RATE SCHEDULE NUMBERS. The description of the item is only indicative and it is not binding. Any description given in the item column is only for the purpose of clarity for manufacturing the item. (the description may change designer to designer and/or drawing to drawing).
- 18.10 Vendors are required to prepare the invoices based on IP /PO wise along with supporting documents and submit to Finance through Outsourcing department. Two invoices per IP/PO is permitted (1st invoice will be minimum 50 % of IP/PO value and remaining value will be covered in second invoice). Third invoice will be permitted based on approval from competent authority on exceptional ground. Invoicing is allowed only for the full quantity of DU/PO line item.
- 18.11 Invoicing for partial dispatches of a PO line item /DU shall not be accepted.
- 18.12 Payment for 2nd bill of a IP/PO shall be made after settlement of FMAS.
- 18.13 If invoices are processed through RXIL mode, the submission of invoice will be allowed only after completion of the Final Material Accounting System (FMAS) for that PO. There is no partial invoicing for RXIL payment processing.
- 18.14 If fabricator fails to complete the FMAS within 30 days of Goods receipt, Payment block will be created and invoice of the fabricator for other IP/PO's also will be blocked for payment.
- 18.15 All Outsourcing invoices including RXIL will be processed by finance only after ensuring entry in the GST portal for that particular invoice.

19.0 PROGRESS REPORT:

The Contractor shall submit progress report from time to time and also discuss with our officials concerning the progress of the work and commitment as may be required by BHEL, Ranipet. The submission, receipt and acceptance of such reports shall not prejudice the rights of BHEL, Ranipet under the Contract nor shall operate as an estoppel against BHEL, Ranipet merely by reason of the fact that they have not taken notice of/or objected to any information contained in such reports. Action as deemed fit will be taken if the progress of the work is not satisfactory.

20.0 BANK GUARANTEE :

- 20.1 The Contractor shall execute a Bank Guarantee to a specified value not less than **Rs.5.00 Lakh** from any one of the Scheduled or Nationalized banks on behalf of the Contractor for the

safe custody of the materials supplied by the BHEL, Ranipet as free issue and for the satisfactory performance of the Contracts. The guarantee shall be executed on a non-judicial stamp paper or value Rs. 100/- as per our standard Bank Guarantee clauses and shall be kept valid for the full contract period & Claim period of additional Three months /One year over the contract period and extensible till final settlement of supply and payment **and BG to be submitted directly by Bankers to BHEL in a Standard format as per Section XII. BG format will be given by BHEL and it has to be filled in that format only.**

- 20.2 In place of Bank guarantee, Fixed Deposit Receipt (FDR) drawn in favour of BHEL, Ranipet can also be furnished. In any case BG/FDR shall be available at the time of signing the contract.
- 20.3 The Bank Guarantee should cover the recoveries to be made by BHEL towards Safe custody of Material Supplied, Scrap / Faulty workmanship, etc. also for which proper material accounting is not made within the stipulated time and shall cover all Contracts past, present and future placed / to be placed by the BHEL, Ranipet. If the recovery amount is more than the pending bills, the difference amount to be settled immediately submitting Demand Draft in favour of BHEL/ Ranipet.
- 20.4 Loading on the vendor shall be restricted in such a way that the value of the materials to be issued and the stock of BHEL materials already available with the vendor.

21.0 BANK GUARANTEE NORMS;

- 21.1 Necessary Bank Guarantee (BG) / Fixed Deposit Receipt(FDR) should be furnished. The Bank Guarantee value applicable for the Firm is indicated in **Section XII** enclosed. The BG shall be kept **valid throughout the contract period PLUS 3 Months /one year as claim period** and must be renewed in-time. It is also to be noted that the BG for the value indicated shall be made available with BHEL at the time of entering into ARC, failing which Firm will not be considered for entering in to contract with BHEL.

The required Bank Guarantee shall be submitted within 15 Days of finalization of the contract, else the non submission of BG will be treated as "not *honoring his own offer* which leads to tampers with tendering procedure affecting ordering process" stated/agreed in the tender and declared fit for taking suitable action by BHEL as per "*Suspension of Business dealings vide Clause S of section IV*".

- 21.2 The release of Contract by BHEL, Ranipet shall be on the strength of Bank Guarantee for the safe custody of raw materials issued by BHEL, Ranipet as free issue in line with **CL. 20.1.**
- 21.3 Based on the capacity declared by the firm, the Sub-contractor may decide the maximum BG value over the base BG value, and the same shall be submitted to BHEL before ordering.
- 21.4 **BG shall be given by bidders for 50% of value of materials** to be issued to the vendor against Job Work Order. The value of materials shall be as per BHEL calculation, which is final.
- 21.5 JWO / Loading on the vendor shall be restricted in such a way that the value of the materials to be issued and the stock of BHEL materials already available with the vendor together do not exceed the value of BG at any point of time.
- 21.6 BHEL reserves the right to increase the value of BG/FDR depending on the material availability with the contractors from time to time. For placement of PO/addendum, if available BG is short of the required BG value, the same will be intimated to the vendor to submit additional BG. The vendor shall arrange for the required BG within 15 days from the date of receiving such intimation from BHEL. If the vendor does not submit the required BG within 15 days, then the loading quantity may be reduced / diverted to other firms. After completion of that particular order, the vendors can request for return of BG (other than base BG) and the same shall be considered by BHEL.
- 21.7 The base BG shall be returned by BHEL after 90 days from the date of final bill submission or ARC validity period whichever is later.

22.0 GUARANTEE OF FABRICATION / MACHINING:

The Contractor shall warrant that the conversion work comply fully with the drawings and other technical conditions. If the jobs are found defective owing to reasons attributable to the vendors like faulty workmanship / incomplete work within a period of eighteen months from the date of handing over to BHEL, the Contractor shall make good of it / replace the same free of cost. Alternatively, the rework / replacement charges will be recovered from the Contractor.

23.0 LIQUIDATED DAMAGES and RISK PURCHASE:

- 23.1 The semi-finished jobs/fabrications on acceptance by BHEL, Ranipet inspector or by their authorized inspection agency, shall have to be delivered to BHEL, Ranipet Stores / Finishing Bay immediately on or before the delivery date stipulated in the addendum. Where the Contractor supplied the finished machining / fabrications beyond the delivery date stipulated in the addendum, liquidated damages at the rate of **1/2%** of the value (Conversion Cost) of the assemblies delayed for each week or part thereof will be levied subject to a maximum of **10%** value of the particular Work Order in the addendum to the Contract for the undelivered portion without prejudice to any other relief or compensation to the BHEL, Ranipet under any other conditions of the Contract.
- 23.2 Further, BHEL, Ranipet will get these items fabricated elsewhere, without notice to the Contractor on the account and at the cost and risk of the Contractor, the jobs not so delivered without canceling the Contract in respect of installments of machining / fabrications not yet due for delivery or cancel the Contract or a portion thereof and, if so desired, fabricate elsewhere at the cost and risk and account of the Contractor. Any additional expenditure incurred by BHEL on this account shall be recovered from the Contractor.
- 23.3 In general, delivery period for each JWO shall be 3 Months from JWO Date/Last material clearance date including further materials, whichever is later. However actual delivery shall be fixed by BHEL for each JWO on project requirement and product lead time.
- 23.4 Where delivery extension is sought with waiver of penalty, the same should be applied to OS with justification and approval to be obtained before delivery to BHEL Stores/Shipping and two copies of such letters (One for Accounts & One for OS Department) are to be enclosed along with all the bills. Failure to comply with this requirement will result in recovery of penalty while processing the bills for payment as stated in **Cl. 23.1** from the same bill and no claims for refund of liquidated damages will be entertained there after.
- 23.5 Reasons like power cut, Labour Issue, Machine Break-down etc., which are controllable by the vendors shall not be accepted as reasons for delay for delivery extension purposes. No compensation shall be given to the Contractors, in case of cancellation/diversion of PO'S beyond the delivery Due Date, even if the Jobs have been processed partly.

24.0 ACTION AND COMPENSATION IN CASE OF BAD WORKMANSHIP:

If any work has been executed with unsound, imperfect or bad workmanship or with materials of inferior quality, the Contractor shall on demand in writing from BHEL specifying the work, material/articles complained of, notwithstanding that the same may have been passed, certified and paid for, forthwith, rectify the work so specified in whole or in part as the case may require, at their own cost and in the event of his failure to do so within reasonable period. BHEL will rectify or remove and re-execute the work at the risk and expense of the Contractor.

25.0 COMPENSATION AGAINST DAMAGE OF MACHINERY/TOOLS AND GAUGES SUPPLIED:

- 25.1 BHEL reserves the right to claim adequate compensation from the Contractor on account of any damage caused to the machinery / equipment / tools and gauges supplied to them for

execution of work, due to careless or faulty handling or negligence on the part of the Contractor. The total cost of recovery will be decided by BHEL.

- 25.2 BHEL shall have general supervision and direction over the work, BHEL has the authority to stop the work, whenever such stoppage may be necessary to ensure the proper execution of the Contract. BHEL shall also have the authority to reject all the works which do not conform to the specification, to direct the application of forces to any portion of the work as, in their judgment is required, and order the force increase or decrease and to decide on the issues which arise in the execution of the work.
- 25.3 BHEL reserves the right to suspend the work or part thereof put a hold on further loading to the Contractor at any time for any reason at its discretion and no claim whatsoever on this account will be entertained.

26.0 SUBLETTING :

- 26.1 The Contractor shall not sublet or assign this Contract or any part thereof without the written permission of BHEL, RANIPET. Subletting or assigning this Contract or any part thereof without such permission BHEL, Ranipet shall be entitled to cancel the Contract and to execute the conversion work elsewhere at the risk and cost of the Contractor and the Contractor shall be liable for any loss or damage which BHEL, Ranipet may sustain in consequence of or arising out of such machining / fabrication elsewhere and also cancellation of registration/temporary suspension of further loading.
- 26.2 However, if the PO/PGMA loading demands part processing / Special Process (like Heat Treatment, Machining, Bending, Shearing, Threading, etc..) of certain items at, other BHEL OS-approved Contractor's works, the same may be allowed with the prior permission of BHEL in writing, indicating the period of returning.
- 26.3 "Movement of BHEL materials from our Contractor's premises to any other Firm(s), if necessary, for the purpose of production related work shall be documented properly, signed by the sender & receiver and the same to be authenticated by the concerned OS official, otherwise such materials will be treated as shortage by Accounts".
- 26.4 The vendors will be allowed to indicate alternate sources for carrying out these intermediate operation, wherein the said other sources shall seek approval from BHEL for carrying out these operations.
- 26.5 These intermediate operations are to be carried out only at the approved sources and addition/deletion to this list will be indicated to the vendors then and there.

27.0 TAXES & DUTIES-GST:

- 27.1.1 Taxes and duties as applicable from time to time, shall be paid extra over the quoted rates. (as per latest GST guidelines)
- 27.1.2 Vendors should provide a valid GST registration number and the same should be clearly mentioned in the offer. If any specific exemption is available, a declaration with due supporting documents need to be furnished for considering the offer. Vendor should get themselves registered and obtain a valid GST registration number as per the GST guidelines
- 27.1.3 In case any changes in GST guidelines as per Gov. Notification , the same shall be applicable from time to time.
- 27.2 Taxes applicable if any will be reimbursed at actual on submission of necessary tax invoice mentioning the GSTN registration number and proof of payment to the statutory authorities.
- 27.3 BHEL will recover applicable GST along with cost of prime material, off cut, scrap including Turning & Boring (T and B) **as per clause 5.1** at the time of finalizing MAS wherever the property in the goods passed on to the Contractor. An Invoice will be issued under relevant rules of GST.

- 27.3.1 Wherever GST is claimed by Contractor as above BHEL shall reimburse the applicable GST presently @ 12% against submission of the following documents:-
- i. GST Registration Certificate
 - ii. Original Tax Invoice (as per GST Rules)
 - iii. Certificate for payment of GST
 - iv. Abstract of GSTR-I & GSTR-3B or any other returns as prescribed from time to time
- 27.3.2 In case BHEL is not able to get input Tax credit (ITC) for the payment made by vendor for any of the reason attributable to vendor , the same shall not be reimbursed/recovered from the bills/claims of the vendor (if reimbursed)
- 27.4 GST TDS deduction at such percentage as prescribed under GST Law from time to time will be made on the value of invoices
- 27.5 Income Tax deduction and surcharge on IT at source at such percentage as prescribed in the Income Tax Act from time to time will be made on the value of the invoices in the absence of Income Tax Exemption Certificate from the concerned Income Tax Officer received and submitted by the Contractor. Contractor has to submit photocopy of PAN Card along with original for verification.
- 27.6** All statutory documents required for execution of contract to be finalized against this enquiry and required from time to time by State/central Govt. Authorities shall be submitted to BHEL, failing which appropriate recovery/actions as deemed fit will be levied from the running bills of the contractor.
- 27.7 Contractors are exempted from payment of GST as they are job workers as prescribed under Section 143(1) of GST Law as amended from time to time for the purpose of free issue of raw materials/semi finished goods to them for carrying out necessary operation and return the finished components without payment of duty to the BHEL RANIPET's factory for further processing. This is subject to subsequent statutory modifications and amendments in force from time to time. Contractors shall comply with the requirements of the said Section and also rules made under GST LAW . This is subject to subsequent statutory modifications and amendments in force from time to time. Besides, Taxes, duties, levies and any other govt. special levies as applicable from time to time, through notifications/amendments to original notification/orders, during the tenure of the rate contract, shall be extra as applicable against valid documentary evidence. Any increase or decrease in this regard will be effected accordingly against valid documentary evidence.
- 27.8 The required raw materials will be issued under the cover of Delivery challan as prescribed under GST Law. The Contractor receiving the materials under above said challan (2 Copies) have to complete the work order and return the finished components and scrap under the cover delivery challan issued by BHEL within 3 months from the date of first issue of materials unless otherwise extended by BHEL and all materials shall be fully accounted for in FMAS. For this purpose Duplicate (ONE) copy of all the Challan shall be returned back to BHEL after duly signing in with seal with FMAS and DC copy. If the materials are not returned/ fully accounted for within three months or such extended period as may be allowed by BHEL, any financial implication on BHEL will be recovered from the Contractor's bills.
- (i) In case of failure of non submission of challan due to reasons not attributable to Contractor, (like non matching of materials, hold informed by BHEL, delay due to cycle time etc.,) is to be intimated to BHEL every month by the Contractor.

- (ii) Incase of direct dispatch to customer site (or) returning of material back to BHEL store, necessary GST formalities have to be complied with by Contractor and also necessary records as per GST Law have to be maintained by the Contractor.
- (iii) FMAS is to be prepared immediately on dispatch in all cases based on which applicable GST on scrap/Off cut will be recovered from Contractor and paid to GST Dept.
- (iv) BHEL, RANIPET will not be responsible for payment of any taxes and duties wrongly paid on account of ignorance of law or otherwise and also duty paid at a later date based on litigation.

28.0 GENERAL :

- (a) BHEL reserves the right to recover the dues if any, from the contractor from any one of the running bills of this contract or any other contract with the contractor or from any other division of BHEL. Vendors disqualify themselves to be an approved vendor of BHEL, in the event , it is found that they carryout activities / business which are in direct competition to BHEL business and accordingly they will be delisted. Vendors / Firms indulging in business practices detrimental to BHEL, will be severely dealt with by the due process of law. In addition to the above conditions the following specific conditions also bound under this contract.
- (b) It is preferred that the Proprietor/Managing Partner/Director as applicable to the company should be easily accessible to BHEL official for day to day interaction and to have the residence within 30 KM from BHEL/BAP for the firms located in and around Ranipet. Any change in the constitution of the Contractor's unit or in shifting of works to a new location, the same shall be made only after getting specific approval from Outsourcing BHEL RANIPET. Any deviation found later will be dealt with as deemed fit including cancellation of registration. Also change of Banker requires the prior approval of BHEL, Ranipet.
- (c) Partnership firms should have the latest Form A (Rule 5) Declaration filed with the Registrar of Firms and private Limited firms should have the current MOA and the copy of the same should be produced at the time of signing the Contract.
- (d) The Contractor is liable for all statutory obligations, including but not limited to taxes and duties, ESI, PF, ED/ST, Labour Acts, Factories Acts, Workmen Compensation Act, etc., for their workers. BHEL, RANIPET will have no liability in respect thereof. Notwithstanding the above, if any demand notice is served by the concerned Statutory authorities for recovery of any of their dues on BHEL, BHEL shall have the right to pay the same without notice to the Contractor and recover the same plus administrative charges of 15% of such amount from the Contractor either from the pending/future bills of the Contractor or otherwise. Such act of repeated default is liable for suspension/stoppage of further business till such time the default/violations get vacated. Notwithstanding anything to the contrary, BHEL shall not be liable for any penalty or interest imposed by any statutory authority due to the action of the Contractor or his employees, workers, agents, etc. .
- (e) The Contractor has to devise suitable scheme whereby the employment of child labour should be regulated in line with the child Labour Act (prohibition and Employment Act 1986).
- (f) All the safety precautions and use of safety equipments are to be followed while carrying out the fabrication and despatch of the same. The Contractor must have proper tools and handling equipments. There should always be a responsible person available at the Contractor's works to oversee the operation and compliance of safety regulations. If any non-compliance with respect to proper safety conditions/requirements, BHEL may withhold visit/inspection, instruct stoppage of work till such time the desired safety requirements/conditions are met with.
- (g) All the documents (Inclusive of Drawings, GMS and Standards) of BHEL made available to the Contractor should be kept in a strict confidence and under no circumstance be made available to others or allow others to make use of them for any other commercial purpose whatsoever. This secrecy clause is binding on the employees of the Contractors also. Any contravention will be subjected to legal action besides suspending business with BHEL. Such documents should be returned to the BHEL, RANIPET destroyed with the prior approval of Outsourcing, BHEL, RANIPET.

- (h) Unauthorized act of engagement of any individual who is a full time employee of BHEL for part time/full time work by the Contractor will be viewed very seriously and such act is liable for suspension/total stoppage of further business dealings with the Contractor by BHEL, RANIPET.
- (i) Should a Contractor has a relation or relations in the case of a firm or a company of the Contractor, one or more of its shareholders or relation or relations of the shareholders employed in BHEL or any ex employee who has retired/resigned within a period of two years as on date of the Contract or at any subsequent date after award of this contract, BHEL shall be informed of the fact at the time of signing the contract and thereafter as applicable and obtain the permission of BHEL for such engagement, failing which BHEL may in its own discretion rescind the contract.
- (j) The Contractor shall not attempt any unethical acts and if they are found indulging in such acts, they are liable to be blacklisted apart from other actions. Contractors indulging in any business practices detrimental to BHEL either directly or Indirectly, will be dealt with severely by the due process of law.
- (k) In case of any internal dispute of the Contractor, such as but not limited to disputes between partners of the Contractor, dispute between Contractor and its employees, the same shall be intimated to BHEL within One Month from the date of dispute. Notwithstanding anything to the contrary, BHEL shall not be made a party any suit or legal proceeding in respect of such internal dispute. In case BHEL is made a party to the same, the Contractor and other party(ies) to the dispute, if signatories to this Agreement, shall indemnify BHEL for (a) all direct and indirect costs expended towards such legal proceedings immediately on the issue of a claim notice to that effect from BHEL and (b) any liability that may be imposed in such legal proceedings against BHEL.
- (l) Payment for all the invoices shall be effected by a crossed A/C payee cheque /EFT/RTGS in favor of the Banker which should be indicated in all invoices of the Contractor.
- (m) In order to ensure safe custody of our materials, leasee of those firms under lease shall ensure that their lease period is valid for minimum of 3 years (from date of signing the contract).
- (n) In addition to the above, our standard General Conditions enclosed shall also apply.
- (o) The entire terms and Conditions contained in this tender shall be deemed to form an integral part of the Contract to be entered.

29.0 BHEL reserves the right to :

- (a) Negotiate with the Contractor who has submitted the Lowest offer for "Payment Rate Schedules" and Highest offer for "Recovery Rate Schedules"
- (b) Distribute the requirements on more than one contractor at the Lowest (for Payment RS) / Highest (for Recovery RS) acceptable rate.
- (c) The rates and other terms and conditions in this contract are applicable for the job work orders likely to be placed by other Departments/Units of BHEL also, for similar items.

30.0 **Primary e-Mail-ID:** Contractors are requested to indicate their own email-Id as "Primary e-Mail-ID", which will only be used for all correspondences (like for MAS and Payment etc..)

31.0 **Arbitration and Jurisdiction:**

- (a) Any dispute between BHEL and the Contractor arising out of or in connection with this Contract, other than those for which BHEL decision is final, shall be referred to arbitration by a sole arbitrator.
- (b) The parties hereto agree that the Sole Arbitrator shall the Unit Head of BHEL, BAP, Ranipet or his nominee. The venue of Arbitration shall be Ranipet, Tamil Nadu. The arbitrator may hold meetings for convenience at such places as per his discretion.

- (c) The award of the Arbitrator shall be final, conclusive and binding on both parties to the Contract.
- (d) Subject to the above, the courts at Ranipet alone have the jurisdiction to decide any dispute arising out of or in respect of the Contract.

Vendors are requested to quote only for the Rate Schedules **(54A)** as per the Technical Bid and Price Bid hosted.

The offers should be submitted as detailed in **Section I to Section XII and Annexures A to K**

BHEL, Ranipet is not responsible for any type of delay in receipt of tender.

BHEL, Ranipet reserves the right to reject any or all the tenders either in full or part thereof at their discretion without assigning any reason thereof.

Thanking you,

Yours truly,

For and on behalf of
BHARAT HEAVY ELECTRICALS LIMITED,

Sr.MANAGER (CONTRACTS) / OS

	Bharat Heavy Electricals Limited (A Government of India Undertaking)		☎: 04172-284030, 284158, 241170
	Boiler Auxiliaries Plant, Ranipet – 632 406		
AN ISO 9001 COMPANY	OUTSOURCING DEPARTMENT		E-Mail : bsmanian@bhel.in
Enquiry No	652002E	Due Date & Time for submission of offers	10.00 Hrs by 13-03-2023
Enq-Dated	02-03-2023	Date & Time of Tender opening	14-00 Hrs by 13-03-2023
SECTION III Technical Description and Rate Schedule Classification ARC 2023-24 for OS RS 54A			

Scope of the enquiry is to finalize the rate for entering into Annual Rate Contract for the year 2023-24 for Complete Manufacture of casing wall, Hopper Walls, insulator supp panels bracket assembly in X25 and other product job similar to plate panels etc, from the raw materials supplied by BHEL. Vendor scope includes collection of raw materials from BHEL (single/multiple) and delivery of finished goods to BHEL shipping. Power tool cleaning and painting is in vendor scope. In case of blast cleaning and painting to be done as per respective painting scheme, the same will be done at BHEL approved source. All extra charges are payable extra as per prevailing ARC rates. All the terms and conditions applicable for prevailing Main ARC shall be applied to this tender also.

1.0 The Total Tonnage tentatively for this Rate Contract is 5000 MT.

The requirements are given in the form of Rate Schedule (RS). Rate Schedule contains Rate Schedule Number, Description of the scope of operation to be carried out Unit and Quantity Anticipated in **2023-24** for ordering.

2.0 Rate Schedule: Rate schedule **54A** is given in the tender. For extra Rate Schedules Ref. **Section IIID**. Extra rate schedule mentioned in the section IIID are indicative. If any changes in rate are there, BHEL prevailing rates only will be operated.

3.0 Extra Rate schedule: Extra works if any carried out as per drawing / QWI / JWO requirement shall qualify for extra payment, as per extra rate schedule listed in **Section IIID**. For extra Rate Schedules Ref. **Section IIID**. Extra rate schedule mentioned in the section IIID are indicative. All Extra rates will be operated as per the BHEL prevailing rate contract rates.

Note: For reference purpose, the current running ARC rates for extra Rate schedule are indicated in **Section IIID**.

4.0 Recovery Rate Schedules: The Rate Schedules E43 and E73 are the recovery Rate Schedules given under EXTRA RS Group in Section IIID.

5.0 Scope of the Operation : Complete Manufacture as per Drawing. The Rate Schedule contains descriptive details of item only. However, during actual release of orders, specific Drawing will be given for manufacturing.

6.0 Mandatory and General Facilities Required : To carry out the operations required on the job for the concerned Rate Schedule, the manufacturing Facilities required like Welding Machines, Presses, Shearing Machines, Measuring Instruments etc. are mentioned against Rate Schedule in **Annexure-FH**.

7.0 Eligibility of Vendors : The vendors who are all having the Facilities required, mentioned against Rate Schedules in **Annexure – FH** can quote for the Rate Schedule.

8.0 Distance Eligibility Criteria- Vendors Location.

Vendors located within the radius of 350 KM from BHEL, Ranipet are only eligible for this tender.

9.0 Quantity : Tentative annual requirement is mentioned against Rate Schedule in the Tender- Technical Bid. This quantity may vary during the currency of the contract according to the receipt of orders by BHEL.

10.0 Technical Bid : Technical specification Document for Rate Schedule is available in the Technical Bid

11.0 Price Bid : Price Bid is available in excel format .Vendor has to download the Price bid format & fill the price and upload in e procurement.

Note: Unit rate only to be mentioned in the price bid. Any Rate indicated other than in Price Bid Part III shall not be considered.

12.0 Drawings : Rate Schedule relates to a group of drawings / PGMAs consisting of similar nature and content of work. List of Drawings are given in **Section V** for reference purpose.

Similar Sketches hosted in the web site are detailing the work content of these drawings. Vendors can view the original Drawings at OS department.

The drawings will be displayed at BHEL for the Vendors who are willing to quote for the Rate Schedule.

Hence it is suggested that, the Vendors has to visit BHEL to study the drawings along with their Technically competent officials to study the operations involved, facilities required and to estimate the cost of operations for quoting.

The fabrication rate are to be quoted based on sketches/drawings indicated.

16.0 Quality Documents: Relevant Quality Work Instructions (QWI), Procedure of Quality Assurance (PR:QA), Welding Procedure Specification (WPS) specified in the Rate Schedule / Drawings are given in **Section X**.

Care: Offers received other than the format hosted in the web site will be summarily rejected. Vendor has to study carefully all the technical requirements before quoting for the Rate Schedules.

Section - III D Extra RS Applicable

Enq .No:- 652002E

Dt 02/03/2023

SI No	Extra RS No	Extra RS Desc	Unit	Rate
1	E01	CONVERSION CHARGES FOR FLAT OUT OF PLATES .	MT	2300
2	E03	MAGNETIC PARTICLE INSPECTION/TESTING [MPI].	MR	60
3	E04	RADIOGRAPHY [RT]	MR	800
4	E07X	DEDUCTION OF TRANSPORT CHAGES FOR DTS 0 TO 100 KMS	MT	1200
5	E07Y	DEDUCTION OF TRANSPORT CHAGES FOR DTS 101 TO 350 KMS	MT	1500
6	E07Z	DEDUCTION OF TRANSPORT CHAGES FOR DTS 351 TO 450	MT	1750
7	E11	25 MIC OF EPOXYZINC RICH PRIMER [EXCEPT WM XXX]	SM	94
8	E14	40 MIC OF WHITE ENAMEL PAINT TO IS2932	SM	58
9	E16	25 MIC OF HEAT RESISTANT BLACK BITUMINOUS PAINT TO IS-158	SM	26
10	E17A	TRANSPORT CHARGES FOR TO AND FRO MOVEMENT OF SEMIFINISHED COMPONENTS FROM YOUR WORKS TO THE WORKS OF CONTRACTOR SITUATED WITH IN 60 KMS FROM YOUR WORKS DOING THE INTERMITTENT OPERATION SUCH AS GALVANIZING/BLAST CLEANING / BALANCING / HEATTREATMENT / OTHER SPECIFIC OPERATION ETC AS PER ENQUIRY.	MT	650
11	E17B	TRANSPORT CHARGES FOR TO AND FRO MOVEMENT OF SEMIFINISHED COMPONENTS FROM YOUR WORKS TO THE WORKS OF CONTRACTOR SITUATED BETWEEN 61 KMS AND 160 KMS FROM YOUR WORKS DOING THE INTERMITTENT OPERATION SUCH AS GALVANIZING/BLAST CLEANING /BALANCING/HEATTREATMENT/ OTHER SPECIFIC OPERATION ETC AS PER ENQUIRY	MT	1000
12	E17C	TRANSPORT CHARGES FOR TO AND FRO MOVEMENT OF SEMIFINISHED COMPONENTS FROM YOUR WORKS TO THE WORKS OF CONTRACTOR SITUATED BETWEEN 161 KMS AND 350 KMS FROM YOUR WORKS DOING THE INTERMITTENT OPERATION SUCH AS GALVANIZING/ BLAST CLEANING/ BALANCING/ HEATTREATMENT/ OTHER SPECIFIC OPERATION ETC AS PER ENQUIRY	MT	2500
13	E18	40 MIC OF HIGH BUILD CHLORINATED RUBBER ZINCPHOSPHATE PRIMER.	SM	71
14	E19	5 MIC OF ETCH PRIMER/WASH PRIMER	SM	65
15	E20	20 MIC OF SYNTHETIC ENAMEL LONG OIL ALKYD TOIS-2932 [SMOKE GREY AND OTHER SHADES]	SM	32
16	E23	25 MIC RUST PREVENTIVE OIL	SM	12
17	E24	20 MIC BLACK ENAMEL PAINT TO IS - 2932	SM	32
18	E27	50 MIC HIGH BUILD EPOXY PAINT TO IS14209 DARK GREY AND OTHER SHADES	SM	75
19	E28	40 MIC EPOXY FINISH PAINT LIGHT GREY AND OTHER SHADES	SM	66
20	E29	75 MIC INORGANIC ZINC SILICATE PRIMER TO IS14946	SM	83
21	E30	30 MIC CHLOROKOTE ZINC PHOSPHATE TO IS 8632.	SM	33
22	E40	TRIAL ASSY OF TOTAL INLET/OUTLET FUNNEL ASSY[PYRAMID SHAPE] COLUMNS, LONGITUDINAL ROOF BEAMS, TRUSSES (X55), SPIRALCASINGS, TURBINE HALL STRUCTURES, DUCTS ,SILENCERS (ASSEMBLED FROM MULTIPLE BLOCKS), BRACKETS IN X25, SUCTION HOOD OF FANS AND ROOF ASSEMBLY OF FANS ETC.	MT	875
23	E43	RECOVERY RATE FOR STAINLESS STEEL [NON-MAGNETIC], NON-FERROUS METAL SCRAP.	MT	98000
24	E51	HR ALUMINIUM PAINT [20 MIC] [UP TO 200 DEGREE C] IS 13183 / 1991 GRADE - III	SM	35
25	E52	HR ALUMINIUM PAINT [20 MIC] [ABOVE 200 DEGREE C] IS 13183 / 1991 GRADE - II	SM	54
26	E54	HR CHIMNEY BLACK PAINT [>250 DEGREE C] / FERROTOL BLACK CHIMNEY [50 MIC]	SM	57
27	E55	EPOXY HB MIO TO IS14209 INTERCOAT [125 MIC]	SM	63
28	E56	ALIPHATIC PU FINISH TO IS13213 OR EQVT. [75 MIC]	SM	70
29	E57	CHLORINATED RUBBER FINISH PAINT DARK GREY [40 MIC]	SM	70
30	E59	ETHYL ZINC SILICATE/ZINC DUST ETHYL SILICATE[75 MIC]	SM	70
31	E60	HB EPOXY ZINC RICH PRIMER [50 MIC]	SM	75
32	E61	CHLORINATED RUBBER BASED TITANIUM OXIDE PIGMENTED INTERMEDIATE PAINT [WHITE] - [50 MIC]	SM	100
33	E62	EPOXY RESIN BASED TWO PACK, TITANIUM OXIDEPIGMENTED INTER- MEDIATE PAINT [WHITE] -[100 MIC]	SM	55
34	E64	RED OXIDE ZINC PHOSPHATE PRIMER 80 MICRONS	SM	45
35	E65	UT OF WELD,BUTT JOINTS OR FILLET WELDS OF COLUMN BASE [ALL WELDS] THICKNESS 12 TO 32MM ASPER AWS D.1.1	MR	55
36	E68	LABOUR COST FOR ONE COAT OF PAINTING. [PAINT- BHEL SUPPLY].	SM	6.3

Section - III D Extra RS Applicable

Enq .No:- 652002E

Dt 02/03/2023

SI No	Extra RS No	Extra RS Desc	Unit	Rate
37	E69	SYNTHETIC ENAMEL TO IS 2932 GREY SHADE RAL 9002 [20 MICRONS].	SM	38
38	E71	ULTRASONIC TESTING [UT] OF PLATES / STRUCTURALS	SM	39
39	E72	CONVERSION CHARGES FOR EXPORT PACKING [FOR FINISHED COMPONENT WEIGHT [DU WEIGHT]	MT	1300
40	E73	RECOVERY RATE FOR STAINLESS STEEL [MAGNETIC] SCRAP	MT	48500
41	E76	CONVERSION CHARGES FOR STRUCTURALS TO STRUCTURALS	MT	1300
42	E77	JOINTS OF CS/ HIGH TENSILE PLATES UPTO 4 MM/RM	MR	63
43	E78	JOINTS OF CS/HIGH TENSILE PLATES 5MM TO 10 MM/RM	MR	190
44	E79	JOINTS OF PLATES 12 TO 20 MM /RM	MR	320
45	E80	JOINTS OF BEAM/CHANNEL UPTO 200 MM /JT.	NO	105
46	E81	JOINTS OF BEAM/CHANNEL 201MM - 300 MM /JT.	NO	127
47	E82	JOINTS OF BEAM/CHANNEL 301- 450 MM /JT.	NO	165
48	E83	JOINTS OF ANGLES UPTO 75X75X8	NO	46
49	E84	JOINTS OF ANGLES ABOVE 75X75X8 UPTO 100X100X12	NO	82
50	E85	JOINTS OF ANGLES ABOVE 100X100X12	NO	120
51	E86	JOINTS IN BEAM /CHANNEL ABOVE 450 MM	NO	350
52	E87	ADDITIONA JOINTS FOR PLATES 21-25 MM/RM	MR	660
53	E88	ADDITIONAL JOINTS FOR PLATES 26-32MM/RM	MR	730
54	E89	ADDITIONAL JOINTS FOR PLATES 33-36 MM /RM	MR	1000
55	E90	ADDITIONAL JOINTS FOR PLATES 37-40 MM/RM	MR	1070
56	E91	ADDITIONAL JOINTS FOR PLATES 41 - 50 MM /RM	MR	1050
57	E92	ADDITIONAL JOINTS FOR PLATES 51-56 MM /RM	MR	1100
58	E93	ADDITIONAL JOINTS FOR PLATES 57 MM AND ABOVE/RM	MR	1800
59	E94	CHLORINATED RUBBER FINISH PAINT (RAL)- 40 MICRONS	SM	40
60	E95	TESTING CHARGES OF GATE/DAMPER ASSEMBLY ELECTRICALLY / PNEUMATICALLY OPERATED UPTO 7 MT	NO	5700
61	E96	TESTING CHARGES OF GATE / DAMPER ASSY ELECTRICALLY / PNEUMATICALLY OPERATED ABOVE 7 AND UPTO 10 MT.	NO	8000
62	E97	TESTING CHARGES OF GATE ASY ELECTRICALLY OPERATED ABOVE 10 MT.	NO	15000
63	E98	EXTRA CHARGES PAYABLE FOR FIXING OF BULB SEALS (BULB SEALS ISSUED AS FREE BY BHEL)	MT	20000
64	E99	JOINTS OF Stainless Steel PLATES UPTO 4 MM/RM	MR	200
65	E100	JOINTS OF Stainless Steel PLATES 5 mm TO 10 MM/RM	MR	395
66	E102	PAINTING - ZINC PHOSPHATE PRIMER - GREY SHADE 40 MICRONS	SM	52
67	E103	% for full CORTEN - A material fabrication - all Rate schedules in GEN, CHIM A, B and C	%	37
68	E105	EPOXY GLASS FLAKE PAINT TO 125 MIC	SM	101
69	E106	HIGH BUILD CHLORINATED RUBBER BASED INTERMEDIATE PAINT 60MIC	SM	75
70	E107	COMMERICAL BLASTING TO SA2	SM	90
71	E108	HEAT RESISTANCE ALUMINIUM PAINT (Gr -I) 400-600°C TO IS 13183 20MIC	SM	57



Enquiry Number: 652002E

Dt.02-03-2023

SECTION IV

GENERAL TERMS & CONDITIONS OF THE TENDER

(FOR GUIDANCE TO THE SUPPLIERS)

Before preparing the offer, vendors are requested to go through the following details carefully

A] Vendor Classification

Vendors to this tender are classified as "(54A)".

MAIN Vendor:

Vendors who are having manufacturing facilities for fabrication/machining with minimum 0.9 Acre Land in single location within the radius of 350 KM from BHEL, Ranipet.

B] Eligibility of Vendors to Quote:

Firms who are having sufficient manufacturing facilities and experience in manufacturing of similar Fabrication / Machining of jobs for Boiler Auxiliaries components like Hopper Walls of without corner welding, Bunker Assembly Bunker Walls, Cable Top, ESP Casing Walls, Roof Panels Assembly without Coller, Insulator Supporting Panels, Brackets etc.. and able to meet Eligibility Criteria (Facility Requirement) mentioned against Rate Schedule can quote for this tender.

Firms already registered with Outsourcing (OS) BHEL/BAP/Ranipet shall indicate vendor code in their offer and indicate PO/IP number if available. If vendor is new, then mention as "New" in the space provided for Vendor Code.

Vendors registered with any unit of BHEL for the similar jobs, shall give details of their registration along with the category registered for.

i) Evaluation Methodology For Eligibility Criteria :

- a. The Techno Commercial bids submitted by the firm will be scrutinized. The eligibility of the firms will be verified based on the pre-qualification criteria of the tender and compliance / confirmation to the tender requirements Rate Schedules by BHEL vendor evaluation team including spot verification if necessary for approval. Only those firms complying with the pre-qualification criteria shall be considered for participation in the tender.
- b. Once the vendor is found to be technically suitable meeting all the technical and commercial requirements of BHEL, price bid of those qualified vendors only will be considered for further processing.
- c. New vendor shall submit **Filled-in Vendor Registration form as in Annexure-K**

Note:

(i) The facilities indicated in the RS should be available in working condition as on date at the time of submission of offer and to be made available for the whole contract period. Vendors shall not quote for the ranges-which are beyond their manufacturing capacity.

(ii) Firm Land shall be owned either by the partners/ proprietor or registered in the name of the firm. In case of Leased land, the lease agreement shall be registered in the name of either by the partners/ proprietor or registered in the name of the firm and valid for a minimum period of 3 years from the date of Tender Opening. Self attested Copy of Registered Lease agreement / own land document to be enclosed along with the tender.



C] Vendors Not Eligible to Quote

Vendors declared / notified as defaulters / poor performers on quality / delivery grounds are not eligible to quote. The vendors with whom the material shortages were found during stock verification and not settled at the time of tender opening will not be considered. Offers if any received such vendors shall not be considered.

Vendors under HOLD by BHEL are not eligible for such RS and vendor delisted/banned are not eligible for whole tender.

D) Conflict of Interest

A bidder shall not have conflict of interest with other bidders. Such conflict of interest can lead to anti-competitive practices to the detriment of Procuring Entity's interests. The bidder found to have a conflict of interest shall be disqualified. A bidder may be considered to have a conflict of interest with one or more parties in this bidding process, if:

- a) they have controlling partner (s) in common; or**
- b) they receive or have received any direct or indirect subsidy/ financial stake from any of them; or**
- c) they have the same legal representative/agent for purposes of this bid; or**
- d) they have relationship with each other, directly or through common third parties, that puts them in a position to have access to information about or influence on the bid of another Bidder; or**
- e) Bidder participates in more than one bid in this bidding process. Participation by a Bidder in more than one Bid will result in the disqualification of all bids in which the parties are involved. However, this does not limit the inclusion of the components/ sub-assembly/ Assemblies from. one bidding manufacturer in more than one bid; or**
- f) In cases of agents quoting in offshore procurements, on behalf of their principal manufacturers, one agent cannot represent two manufacturers or quote on their behalf in a particular tender enquiry. One manufacturer can also authorize only one agent/dealer. There can be only one bid from the following:**
 - 1. The principal manufacturer directly or through one Indian agent on his behalf; and**
 - 2. Indian/foreign agent on behalf of only one principal, ·**

or

- g) A Bidder or any of its affiliates participated as a consultant in the preparation of the design or technical specifications of the contract that is the subject of the Bid ; or**
- h) In case of a holding company having more than one independently manufacturing units, or more than one unit having common business ownership/management, only one unit should quote. Similar restrictions would apply to closely related sister companies. Bidders must proactively declare such sister/ common business/ management units in same/ similar line of business.**

E] EMD (Earnest Money Deposit)

Non MSE Vendors has to submit EMD for Rs. 2.00 Lakh in the form of Demand Draft favouring "Bharat Heavy Electricals Ltd., Ranipet – 632 406" payable at Ranipet (Original copy should reach BAP RANIPET before tender opening). **EMD is applicable for Medium category vendor also.**

BHEL has now made arrangements for payment of EMD thru' Online. The steps to make online payment is detailed as below:



- 1) Visit <https://www.onlinesbi.sbi/sbicollect/collecthome.htm>
- 2) Click 'Proceed' button
- 3) Select '**Tamilnadu**' in the drop down menu under 'State of Corporate/Institution **'
- 4) Select '**PSU-PUBLIC SECTOR UNDERTAKING**' in the next drop down menu under " Type of Corporate/Institution"
- 5) Click 'Go' button
- 6) Select '**BHEL BAP RANIPET**' in the drop down menu under "PSU-PUBLIC SECTOR UNDERTAKING"
- 7) Click 'Submit' Button
- 8) Select '**EMD**' in the drop down menu under ' Select Payment Category'
- 9) Now Fill in the required details and ensure correctness of data filled. Ensure that you are entering correct enquiry/tender number and other details correctly.
- 10) Make payment for EMD as required in tender after entering the details and enclose copy of receipt along with tender documents.

(i) No interest shall be payable by BHEL on Earnest Money Deposit (EMD).

(ii) EMD will be forfeited if

- a) The Tenderer withdraws his Tender within the validity period,
- b) After becoming L1, if the firm does not sign the contract or not submitting the required base BG within the specified period, the EMD will be forfeited.

(iii) The EMD submitted by the vendors will be returned within a month from the date of signing the contract.

F] Validity of Offer

Price validity shall be One Year from the date of finalisation of Annual Rate Contract; however the validity date of the offer is 180 days from the date of tender opening for ordering.

G] Submission of Offer

TENDERS

An electronic Bids shall be submitted in three parts namely (i) Earnest Money Deposit (EMD) fee Cover/ valid MSE document (ii) Techno Commercial Bid Cover and (iii) Price bid cover.

The details of contents of the offer covers are as under:-

Cover I: EMD / MSME Requirements

- a) **Check list for Cover-I**
- b) **Earnest Money Deposit (EMD) Rs. 2.00 lakh** in the form of Demand Draft, as called for (for Non MSE supplier), **(OR)**
- c) **MSE documents** to avail exemption from submission of EMD: –
 - i) UDYAM REGISTRATION CERTIFICATE (URC)

Date to be reckoned for determining the deemed validity will be the date of Tender opening. Non submission of such documents will lead to consideration of their bids at par with other bidders and MSE status of such suppliers shall be shifted to Non MSE supplier till the supplier submits these documents.

Cover II: Qualifying Criteria, Techno-Commercial Bid

- a) **Check list for Cover-II (Annexure-B)**
- b) **Signed in Standard Commercial Terms & Conditions format** given as **Annexure-E.**,
- c) **Signed in Technical Bid** for each Group quoted in this tender (without Price) as per **Annexure-C.**



- d) **Signed in Section III D** for Extra Rate Schedule
- e) **Affidavit** in Stamp Paper value Rs.100 as per **Annexure-I**
- f) **Own land** - Document copy / **Lease Land** – Self attested Copy of Registered Lease Agreement and Encumbrance Certificate covering past 20 years for Own/Lease land.
- g) **Integrity Pact** as per **Annexure-H**
- h) **Documents to be enclosed for Partnership Firm –Self Attested Copies**
- i) Latest Form- A, issued after 01.04.2022.
- ii) Partnership Deed Copy (AT WILL).
- i) **Documents to be enclosed for Limited Firm (Private Firm) – Self Attested Copies**
- i) Latest resolution by Board of Directors.
- ii) Memorandum of Article of Association.
- iii) Company's Affidavit for existence
- iv) Latest Annual Report.
- v) Directors Share details
- j) **Vendor Registration Form** given as **Annexure-K** along with all necessary documents (**For New Vendor**)
- k) **Eligibility Criteria format** given in **Annexure-FH**

Important Note 1:

Technically qualified vendors who have submitted the following documents for the tender enquiry MAIN-OS-ARC-652001E dt.09.09.2022, need not submit the same again for this tender.

SI.No. f) Land Document along with EC, h) Partnership firm Documents i) Private firm documents

Declaration in Annexure-B is required for confirmation.

Note:

- (i) All new firms shall submit vendor registration forms (**Annexure-K**) along with supporting documents.
- (ii) Price bids of firms failing to meet the Technical Qualification / Eligibility Criteria of the quoted Rate Schedules shall not be considered for further processing in the tender.
- (iii) Rates shall not be indicated anywhere in the Technical Bid.
- (iv) All Annexure to the Techno-Commercial bid should be serially numbered.
- (v) Tenders not submitted in the prescribed formats given in the Annexures like Standard *Commercial Terms & Conditions, Technical Bid*, etc. and *incomplete offers* are liable for rejection.
- (vi) Documents shall be annexed in the order specified above (**clause a to k of cover-II**)

Cover-III : Price Bid

Price Bid - Price duly filled-in the Price Bid format provided in the tender document as **Annexure-D** 54A BOQ

The Prices shall be indicated in figures .Unit rate only to be mentioned in the price bid.

Any Rates indicated other than in Price Bid Cover III shall not be considered.

Note:



- i) The price should be on “FOR BHEL, Ranipet” basis only (Inclusive of packing, forwarding and freight charges). No other delivery terms shall be acceptable.
- ii) While quoting their rates, the Bidders are advised to take into account the likely expenditure, escalations, statutory requirements & levies, labour laws, safety requirements, taxes, etc during the operation of Rate Contract for one year from the date of award of Contract. No price escalation/variations shall be entertained during the ARC period on any account. The rates are operative for placement of orders for **ONE YEAR** on Rate Contract basis to be entered into between BHEL and the Contractor.
- iii) Tenderer shall bear all cost incidentals to preparation, submission and negotiations of the tender.
- iv) If BHEL withdraws the Tender before or after the receipt of offers, whether the offer is accepted or not, tenderer shall not be entitled to claim any costs, charges, expenses incidental or incurred by him through or in connection with the submission of the offer.
- v) In case, there is a discrepancy in the term quoted in techno-commercial bid and price bid, the term as per the techno-commercial bid (Cover II) shall hold good and the commercial term quoted in the Price Bid (Cover III) shall not be considered.
- vi) In their own interest, all Tenderers are advised to double check their prices before submitting the offer.
- vii) The quotation should be valid at least for a period of 180 days from the tender opening date.
- viii) vacant
- ix) The offers should invariably contain Signature (ink-signed) & Office Stamp of the Supplier. Any corrections / erasures in the offers should be initialled and stamped.
- x) Bidders should submit the prices in Indian Rupees only.

H] Persons Authorized for Signing the Offers:

The Tender documents shall be signed by the Authorized Signatory Only.

- i) Proprietary Firm:** In case of Single Ownership / Proprietorship establishment, the Tender shall be signed by the Owner / Proprietor Only.
- ii) Partnership Firm:** In case the Bidder is a Partnership Firm under Partnership Act, the Tender shall be signed by all the Partners of the firm or by the Managing Partner who have Signature and Seal of the Firm authorized to do so **OR** by a person holding the Power of Attorney on behalf of the Partnership Firm. Power of Attorney attested by a **Public Notary** shall accompany the Techno-Commercial-Bid. Power of Attorney shall be submitted as per format given as **Annexure J** only.
- iii) Private Firm:** Authorized signatory shall be the person holding “Power of Attorney” on behalf of the firm/company/Bidder-concerned and authorized/empowered by MD or Board of Directors or owner of the firm, to act on behalf of the firm for quoting this Tender and all proceedings connected with, till finalization and execution of the Contract. Power of Attorney attested by a **Public Notary** shall accompany the Techno-Commercial-Bid.
- iv)** This tender is being floated through E Procurement Portal. Submission of requisite documents for tender are being submitted by the Authorized Signatory of the Firm.
- v) For participating in the e-tender, Digital Signature Certificate Class III is mandatory for the subcontractor to quote.**
- vi)** Subcontractors should quote the rate and fill other required details only in the respective fields provided.



- vii) The offer should be submitted on or before the due date & time mentioned in the Procurement portal. Further tender due date extension, if any, will be communicated through E-procurement portal only. Hard copy bid or bids through E-mail / fax shall not be accepted.
- viii) Subcontractor should take utmost care for the use of their Digital Key registered while participating in a Tender.
- ix) Latest updates on the important dates, Amendments, Correspondences, Corrigenda, Clarifications, Changes, Revisions, etc. to Tender Specifications will be hosted in E Procurement portal

I] Opening of Offers

a) Tenders (Offers) shall be received upto 14.00 Hours on the said due date. The times indicated are Indian Standard Time (IST).

b) It is bidder's responsibility to ensure that the Tenders are submitted before the specified date and time. BHEL shall not be responsible for any postal delay.

c) First Cover I containing EMD / MSME documents shall be opened, only if EMD as mentioned above OR the valid MSME certificate is available, the respective Cover II - Techno Commercial bid will be opened subsequently.

d) Price Bid opening followed by Reverse Auction method will be done. All tenderers would have to specifically give their acceptance for this in their bid/s. The date / time of Price Bid opening will be communicated to the technically qualified Bidders separately.

J] Evaluation of Techno Commercial Offers

The Techno commercial bids submitted by the firm will be scrutinized. The eligibility of the firms will be verified based on the pre-qualification criteria of the tender and compliance / confirmation to the tender requirements for each Rate Schedules/ Group of Rate Schedules quoted. Only those firms complying with the pre-qualification criteria shall be considered for participation in the tender. Once the vendor is found to be technically suitable meeting all the technical and commercial requirements of BHEL, price bid of those qualified vendors for respective category only will be considered for further processing.

Offers of vendors not technically qualified will be rejected and the same will be communicated to the vendors with reasons.

No deviation or change from the Tender conditions will be allowed and BHEL reserves the right to reject such offers.

Conditions for rejection of offers:

Following is the list of situations which would lead to rejection of offer/s.

This list is not exhaustive but only indicative.

BHEL reserve the right to reject one or all offers without assigning any reason. The decision of BHEL will be final in this regard.

- 1. If the offer fails to meet the technical requirements/specifications of the tendered item/s.*
- 2. If the offer does not meet the commercial terms & conditions, such as but not limited to delivery period specified in the tender, Delivery terms, payment terms, Liquidated damages, Risk Purchase, cancellation clause etc., specified in the tender.*



3. If the bidder fails to respond to clarification sought, within a reasonable period. In case of doubts / lack of clarity on the technical and commercial offer of the bidder, BHEL will seek clarifications. Bidders are required to respond completely to such BHEL's queries within 3 working days unless otherwise agreed to in writing by BHEL for period beyond 3 days. If supplier fails to respond within 3 working days or maximum 2 working days on a reminder thereon, the offer of such bidders will be automatically dis-qualified in the tender without further recourse to informing the bidder.

KJ Evaluation of Price Bid

- i) The rates quoted shall be evaluated RS wise on the basis of "Total cost to BHEL".
- ii) In the course of evaluation, if more than one bidder happens to occupy L1 status, effective L1 will be decided by soliciting discounts from the respective L1- bidders. In case more than one bidder happens to occupy the L-1 status even after soliciting discounts, the L1-bidder shall be decided by a toss/draw of lots, in the presence of the respective L-1 bidder(s) or their representative(s). Ranking will be done accordingly. BHEL's decision in such situations shall be final and binding.
- iii) If more than one bidder happens to occupy same status other than L1 or H1 the following methodology will be followed. The sub-ranking will be done in the order by providing lower ranking for vendors
- (1) Nearer to BHEL by location
 - (2) Earlier date of commencement of activity as in MSME certificate
 - (3) Having OWN land,
 - (4) Draw of lots as a final measure (in presence of such vendors, who may like to be present).
- iv) Tenderer contacted in this tender does not automatically qualify for consideration just because they are found to be the lowest in Tender. BHEL reserves the right to reject any offers without assigning any reasons. BHEL also reserves the right to negotiate or counter offer the rates to any of the parties at their discretion.
- v) If the L1 rate against any rate schedules are found not acceptable to BHEL, then the L1 firms may be called for negotiation before finalizing the rate.
- vi) BHEL has the right to refloat or short-close the Tender if L1 price is not the lowest acceptable price, or for other reasons.
- vii) After price bid opening but before placement of order, Supplier withdraws his offer or varies it in any manner within the validity period, suitable action will be taken as per guidelines for Suspension of Business Dealings.
- vii) Elimination of Vendors:**
- a) H1 vendor will not be considered. In case of tie in H1 position, then all tied bidders will be deemed as H1.**
 - b) Maximum vendors are required for entering in to contract except H1 vendors.**
- viii) All bidders shall submit their offers by filling-in the format of the BHEL tender documents. Offers received in any other format are liable to be rejected. Offers are asked in BHEL's format for purpose of standardisation - to help in the offer evaluation.
- ix) Offer with any pre-conditions (like conditional discounts) for price is liable for rejection.
- x) BHEL reserves the right to reject without assigning any reasons other than already specified for such offers having deviations to BHEL Specifications, Standard Terms & Conditions at its discretion. The decision of BHEL in this regard shall be final.



- xi) In case of any discrepancy between the description of the Rate Schedule or quantities, specifications, drawings and for other tender documents, the decision of BHEL in writing is final, binding and conclusive for the purpose of this contract.
- xii) BHEL reserves the right to reject an offer due to unsatisfactory past performance during tender finalisation / execution of a contract at any of BHEL projects / units.
- xiii) BHEL reserves the right to conduct negotiations on the "Price" and "Other Commercial Terms and Conditions" with the lowest ranked offeror and
- xiv) If so required by BHEL, Supplier may have to share their cost data / costing sheet with BHEL.
- xv) BHEL reserves the right to restrict the number of parties for award of contract for any or all the Rate Schedules and restrict the number of parties to be called for negotiation (if necessary) based on their competitive bidding, past performance etc.

L] Abnormally Low Offers

If the prices offered by L1 Bidders are found to be unrealistic, unworkable with respect to BHEL's estimate or prevailing market rates, BHEL will ask for justification also demand the break up cost element for such rates from the vendors with appropriate documentary evidence and if not submitted it will be construed that the vendor has offered the rates with an intention to sabotage BHEL Tender process/ tamper Tendering procedure, affecting the ordering process. In such cases, BHEL will have the discretion to reject the offer in line with BHEL procedures. Hence the bidders are advised to exercise abundant care in submitting a correct genuine offer.

M] Counter offer

- i) Once the L1 rates for the rate schedule is finalized by BHEL, then the L1 rate shall be counter offered to the other technically qualified vendors for their acceptance.
- ii) Based on the acceptance of vendors for the Rate Schedule, rate contract will be entered with them.
- v) Counter offering will not be extended to top higher ranked (H1.etc.) eliminated vendors as per **clause K (vi)** Counter offering will be made to all participated vendors except H1 ranked vendors .
- vi) If none of the vendors are accepting for the counter offer given by BHEL, then BHEL will place orders on the L1 ranked vendor for the tentative quantity mentioned subject to the capacity availability indicated by the vendor.

N] Placement of Orders and Loading

- a) ARC Contract will be entered only with the **vendors** who respond to this ARC-Enquiry. New vendors who have not responded to this ARC-Tender-but registered/approved later, if any will be permitted in the next year ARC (provided they respond to the next-year ARC).
- b) Annual Rate Contract would be signed by the vendors for the Rate Schedule by way of becoming L1 and accepting counter offer rates for the Rate Schedule with BHEL, Ranipet subject to the availability of requisite acceptable Bank Guarantee.
- c) Tentative quantity likely to be ordered against Rate Schedule is indicated in the Technical Bid. Tender quantity may increase/decrease during the rate contract period. BHEL does not guarantee any minimum load for any vendor.
- d) The contract is to be signed in Rs.100/- stamp paper. Hence after getting a confirmation on signing of contract, vendor shall get a stamp-paper for a value of Rs. 100/- and submit to BHEL for contract preparation.



- e) After finalization of tender, if the Contractor is awarded the Contract, Proprietor, Partners and Directors (as applicable) should physically present themselves and sign the contract in the presence of Head of OS Department with in the dates specified.
- f) Orders would be placed as Addenda's on the Annual Rate Contract signed by the vendors.
- g) *Lowest (L1) vendor will be given TWO (2) splits of load, when all other ranked vendors (other than L1) were given One (1) split, during every bulk loading cycle, subject to meeting all the basic requirements such as Tender ranking, Capacity availability, Availability of BG, Delivery & Quality Performance, Legal compliances, validity of lease document if applicable and Validity of constitution., required as per contract. In case the above said requirements are not complied, loading of two splits for L1 vendor and one split for other ranked vendor will not be considered for subsequent loading.*
- h) If none of the vendors are accepting for the counter offer given by BHEL, then BHEL will place orders on the L1 ranked vendor for the tentative quantity mentioned against RS subject to the capacity availability indicated by the vendor.
- i) vacant
- j) Purchase orders will be issued after entering into Rate contract with the Contractors. Discrepancy in the PO's if any, has to be settled immediately then and there within 20 days from the date of release of PO.

O] Execution of the Order

a) Once the order is released, vendor can view the orders in B2B portal of BHEL, Ranipet. However vendor has to collect hard copies of Engineering Drawings and relevant documents from BHEL through their authorised representative.

Based on the Rate contract, to be finalized, the Sub-Contractors shall accept and undertake all jobs awarded to them under various Rate Schedules allotted to them and execute them to the satisfaction of BHEL. Failure to comply with this requirement will be viewed seriously.

- b) Vendor has to collect Raw materials / Components from BHEL stores / Shop to their works on clearance.
- c) Vendor has to study the Drawings, Welding Procedure Specification (WPS), Standard Quality Plan (SQP), any Customer Hold Points (CHP), any stage inspection requirement etc. carefully before start of manufacture.
- d) Vendor has to submit Cutting Plan (CP) for the collected Raw Materials within a week of collection and shall get approval from CP section before proceeding for manufacture.
- e) During manufacturing, wherever stage inspection is required, vendor has to offer for inspection to BHEL QC / BHEL approved Inspection Agencies for clearance to proceed further.
- f) All measuring Instruments to be calibrated as per standards at BHEL Metrology / any approved Labs on chargeable basis and manufacturing / inspection will be carried out with calibrated instruments only.
- g) On completion of Job, final inspection is to be offered to BHEL QC / BHEL approved Inspection Agencies with relevant Dimensional Report (DR). After clearance from the above agencies, Inspection Report (IR) has to be obtained for the same.
- h) Painting of one coat Red Oxide / applying of Rust Preventive oil on machined surfaces is to be made on the job.
- i) Despatch the items to BHEL, Shipping / Stores along with Delivery Chelan (DC), Inspection Report (IR), and Dimensional Report (DR) each 6 copies and shall get Inward Entry on Delivery Chelan (DC) from the Gate In charge.



- j) On delivery, authorised representative of vendor shall follow Shipping / Stores to control the DC's/Stores Receipt Voucher (SRV).
- k) Intimation of controlled DC's/SRV will be mailed by Finance to vendors for submitting the Invoices.
- l) Vendors have to submit the invoice and relevant documents to finance in stipulated time for the release of payments.
- m) In case of new vendors, The Inspection report on **First-of-trial** of First-addendum-PO shall be submitted. Further loading of jobs will only be considered after the successful completion of the First-addendum-PO.
- n) The Contractors are responsible till the semi finished components are safely deposited with BHEL / Ranipet. They should carefully pack, Load, and stack as per QWIs, for avoiding damages during transit and lash the consignment properly at the time of dispatch so that the consignment reach the destination safely.

P] Risk Purchase

In case of delay in delivery beyond PO delivery / mutually agreed delivery, or Subcontractor fails /refuses to complete the PO as per terms or insufficient facilities at Subcontractor's works to execute a PO or default by Subcontractor of any nature, BHEL has the right to get the items ordered elsewhere at the risk and cost of the subcontractor with notice to the subcontractor; and the additional expenditure / difference in cost, if any, including consequential cost shall be recovered from the defaulted subcontractor.

In addition, BHEL may recover from the default Subcontractor any loss to BHEL arising due to default by Subcontractor of any nature and action shall be taken as per latest revision of BHEL Guidelines for Suspension of Business dealings with Suppliers / Contractors.

Sub-contractor pending payments shall be withheld and/or their BG may be invoked to cover the liabilities of BHEL towards risk purchase, if any.

No compensation shall be given to the Subcontractor, in case of cancellation/diversion of PO(s) even if the jobs have been processed partly.

Process of calculating the risk and cost amount is as follows:

Risk & Cost Amount= [(A-B) + (A x H/100)]

Where,

A= Value of Balance scope of Work/ Supply (*) as per rates of new contract

B= Value of Balance scope of Work/ Supply (*) as per rates of old contract being paid to the contractor/ supplier at the time of termination of contract.

H = Overhead Factor to be taken as 5

In case (A-B) is less than 0 (zero), value of (A-B) shall be taken as 0 (zero).

Q] Liquidated Damages:

BHEL will levy penalty as Liquidated Damages (LD), for delay in delivery. The damages shall be at the rate of ½% per week or part thereof subject to a maximum of 10% value of the particular Work Order in the addendum to the Contract for the undelivered portion. Delivery for purpose of L.D, will be reckoned as the date of clearance of the items for dispatch by BHEL. Supplier should quote a definite delivery period and any delay in delivery will attract penalty.

The delivery period includes time involved in material collection, cutting plan approval, collection of further materials if any and handing over of the finished goods to BHEL-Shipping. Finished goods items shall be door delivered at Shipping/Stores inside the factory, BHEL, Ranipet.

R] Termination of Inquiry / Orders:

- a) BHEL reserves the right to cancel any inquiry before opening of the tender, without assigning any reason.
- b) BHEL reserves the right to cancel any tender and refloat a fresh tender, at any time after opening of the tender, in case it finds the response to its tender as not meeting its requirement. This shall be at the sole discretion of BHEL.



c) In the event of non-performance of the contract by the Supplier, BHEL reserves the right to cancel the order with issue of a written notice. BHEL would provide a curing period of 30 days, for the Supplier to rectify the situation. If the Supplier fails to rectify the reason/s that led to the issue of cancellation notice by BHEL, then the cancellation order would be issued automatically by BHEL, without further recourse to the Vendor. BHEL will not pay any cancellation charges or any other charges / damages to the Supplier, arising out such cancellation.

d) In the event of the non-performance of the contract, by the Supplier, the rights of BHEL include, in addition to cancelling the order, to take alternate action at the cost and risk of the supplier. The additional expenditure to be incurred by BHEL in such alternate action would be to the account of the supplier.

e) BHEL reserves the right to cancel the order for delay in supply beyond penalty period without any monetary or legal obligations and at the risk and cost of the Supplier and

f) BHEL will levy penalty as Liquidated Damages (LD), for delay in delivery. The damages shall be at the rate of ½% per week or part thereof subject to a maximum of 10% value of the particular Work Order in the addendum to the Contract for the undelivered portion. Delivery for purpose of L.D, will be reckoned as the date of clearance of the equipment for dispatch by BHEL.

S) Suspension of Business Dealings with vendors

The offers of the bidders who are under suspension as also the offers of the bidders, who engage the services of the banned firms, shall be rejected. The list of banned firms is available on BHEL web site www.bhel.com. Vendors are requested to read the Guidelines for Suspension of business dealings with Suppliers /Contractors are available on BHEL website <https://www.bhel.com/supplier-registration> before quoting.

1.0 Integrity commitment, performance of the contract and punitive action thereof:

1.1. Commitment by BHEL:

BHEL commits to take all measures necessary to prevent corruption in connection with the tender process and execution of the contract. BHEL will during the tender process treat all Bidder(s) in a transparent and fair manner, and with equity.

1.2. Commitment by Bidder/ Supplier/ Contractor:

1.2.1. The bidder/ supplier/ contractor commit to take all measures to prevent corruption and will not directly or indirectly influence any decision or benefit which he is not legally entitled to nor will act or omit in any manner which tantamount to an offence punishable under provision of the Indian Penal Code, 1860 or any other law in force in India.

1.2.2. The bidder/ supplier/ contractor will, when presenting his bid, disclose any and all payments he has made, and is committed to or intends to make to agents, brokers or any other intermediaries in connection with the award of the contract and shall adhere to relevant guidelines issued from time to time by Govt. of India/ BHEL.

1.2.3. The bidder/ supplier/ contractor will perform/ execute the contract as per the contract terms & conditions and will not default without any reasonable cause, which causes loss of business/ money/ reputation to BHEL.

If any bidder/ supplier/ contractor during pre-tendering/ tendering/ post tendering/ award execution/ post-execution stage indulges in mal-practices, cheating, bribery, fraud or and other misconduct or formation of cartel so as to influence the bidding process or influence the price or acts or omits in any manner which tantamount to an offence punishable under any provision of the Indian Penal Code, 1860 or any



other law in force in India, then, action may be taken against such bidder/ supplier/ contractor as per extant guidelines of the company available on [www. bhel.com](http://www.bhel.com) and/or under applicable legal provisions”.

Submission of offer shall be deemed to be evidence of the Bidder to have read and understood the above said policy.

T) Reverse auction (RA) :

- 1.1 BHEL shall be resorting to Reverse Auction (RA) (Guidelines as available on www.bhel.com) for this tender. RA shall be conducted among the techno commercially qualified bidders. Price bids of all techno commercially qualified bidders shall be opened and same shall be considered for RA. In case any bidder(s) do(es) not participate in online Reverse Auction, their sealed envelope price bid along with applicable loading, if any, shall be considered for ranking.
- 1.2 The philosophy followed for reverse auction shall be English Reverse (No ties).
- 1.3 For the proposed reverse auction, technically and commercially acceptable bidders only shall be eligible to participate.
- 1.4 BHEL will engage the services of a service provider who will provide all necessary training and assistance before commencement of on line bidding on internet.
- 1.5 Before reverse auction, BHEL will inform the bidders the details of Service Provider to enable them to contact & get trained.
- 1.6 Business rules like event date, time, bid decrement, extension etc. also will be communicated through service provider for compliance.
- 1.7 Bidders have to fax/E mail the Compliance form before start of Reverse auction. Without this, the bidder will not be eligible to participate in the event.
- 1.8 Reverse auction will be conducted on scheduled date & time.
- 1.9 The lowest bidder has to fax/e-mail the duly signed and filled-in prescribed format for price breakup including that of line items, to the Service provider within two working days of Auction without fail.
- 1.10 Bidders are required to read the “Terms and Conditions” section of the auctions site of Service provider, using the Login IDs and passwords given to them by the service provider before reverse auction event. Bidders should acquaint themselves of the „Business Rules of Reverse Auction”, which will be communicated before the Reverse Auction.
- 1.11 If the Bidder or any of his representatives are found to be involved in Price manipulation/ cartel formation of any kind, directly or indirectly by communicating with other bidders, action as per extant BHEL guidelines, shall be initiated by BHEL and the results of the RA scrapped/ aborted.
- 1.12 The Bidder shall not divulge either his Bids or any other exclusive details of BHEL to any other party.
- 1.13 . The calculation sheet e.g. excel sheet (which will help to arrive at ‘Total Cost to BHEL’) will be communicated to respective bidders of RA by BHEL. In line with the NIT terms, BHEL will provide the calculation sheet (e.g., EXCEL sheet) which will help to arrive at “Total Cost to BHEL” like Packing & forwarding charges, Taxes and Duties, Freight charges, Insurance, Goods & Services Tax (GST) and loading factors (for non-compliance to BHEL standard Commercial terms & conditions) for each of the bidder to enable them to fill-in the price and keep it ready for keying in during the Auction.]
- 1.14 This calculation sheet will be finalized based on the evaluation criteria specified in the NIT.
- 1.15 Start price for RA shall be lowest of sealed envelope price bid.
- 1.16 Wherever more than one lowest sealed envelope price bids are identical and lower than the estimate, the start price, would be that price arrived by reducing the lowest sealed envelope price bid by maximum of one decrement.
- 1.17 The start price & bid decrement will be decided by RA committee of BHEL and the same would be communicated to the service provider, to start the bidding process.
- 1.18 Only those bidders who have submitted the ‘Process compliance form’ duly signed and within the scheduled time would be eligible to participate in RA process.
- 1.19 Reverse Auction will be conducted if two or more bidders are techno commercially qualified. In case of two or three qualified bidders, there shall be no elimination of H1 bidder (whose quote is highest in sealed envelope price bid). In case of four qualified bidders, the H1 bidder shall be eliminated whereas in case of five qualified bidders, H1 & H2 bidders shall be eliminated. However, in case of

six or more qualified bidders are available, RA would be conducted amongst first 50% of the bidders arranged in the order of prices from lowest to highest. Number of bidders eligible for participating in RA would be rounded off to next higher integer value if number of qualified bidders is odd (e.g. if 7 bids are qualified, then RA will be conducted amongst lowest four bidders). However, there will be no elimination of qualified bidders who are MSE or qualifying under PPP-MII, Order 2017, irrespective of the number of bidders qualifying techno-commercially.

- 1.20 In case of multiple H1 bidders, all H1 bidders (excluding MSEs and bidders qualifying under PPP-MII, Order 2017) shall be removed provided minimum two bidders remain in fray, else no H1 removal.
- 1.21 The lowest bidder in sealed envelope price bid shall be shown as current L1 automatically by the system. System shall have the provision to indicate this bid as current L1 for further bidding. This price can be displaced by an even lower bid of a competing bidder.
- 1.22 If the start price is lower than the lowest sealed envelope price bid (in line with clause 8.0), on acceptance of such start price by any bidder this bid would be indicated as current L1 for further bidding. However, if no bidder accepts the start price, RA shall be treated as cancelled for the respective line item(s) and the tender shall be processed accordingly.
- 1.23 In case of no further bidding, RA will be deemed to have been successful with current L1 bidder.
- 1.24 During RA, all bidders will see their rank and current L1 price on the screen. Once the RA is done, the ranking status would be based on the last quoted price of the bidder(s) irrespective of the quote received in RA or sealed envelope price bid.
- 1.25 No bidder shall be allowed to lower its bid below the current L1 by more than 5 decrements at one go.
- 1.26 Wherever the evaluation is done on total cost basis, after RA, prices of individual line items shall be reduced on pro-rata basis.
- 1.27 In case of splitting requirement, H1 bidder(s) who were removed from participation in RA may also be considered for counter offer if the pre-stated (NIT) number of suppliers do not accept the counter offer. However, the principle of splitting to N-1 bidder shall be maintained in line with extant Purchase Policy / Work Policy
- 1.28 Reasonability of rates received through RA to be ascertained as per extant Policy provisions.
- 1.29 In case of enquiry through e-Procurement, the sealed electronic price bid (e-bid) would be treated as sealed envelope price bid.

Note: In order to bring more transparency and to address any queries of Bidders on Reverse Auction, an abridged version of BHEL's "Common Guidelines for conducting Reverse Auction (RA)" has been hosted in BHEL's web site www.bhel.com under the links "Supplier Registration Page" and "Tender Notification". All Bidders are requested to visit the link and familiarize themselves with BHEL's RA procedures and guidelines before submission of their bid/s. Submission of Bid shall mean that the Bidder has read and understood BHEL's RA procedures and the bid is in agreement with the same.

UJ Force Majeure

i) If at any time during the currency of this contract, the performance in whole or in part, by either party of any obligations under this contract shall be prevented or delayed by reason, of any war, hostilities, acts of the public enemy, civil commotion, sabotage, fires, explosions, epidemics, quarantine, restrictions or acts of GOD (hereinafter referred to as events), then provided notice of happening of any such events is given by either party to other within ten days from the date of occurrence thereof, neither party shall reason of such events be entitled to terminate this contract nor shall either party have any such non performance and delay is resumed as soon as practicable after such events has come to an end or ceased to exist. If the performance in whole or part of any obligation under this contract is prevented or delayed by reason or any such event claims for extension of time shall be granted for period considered reasonable by the purchaser subject to prompt notification by the seller to the purchaser of the particulars of the events and supply to the purchaser if required of any supporting evidence. Any waiver of time in respect of partial installment shall not be deemed to be a waiver of time in respect of remaining deliveries.



ii) If as a result of difficulty in procurement of raw materials or due to force majeure reasons or any other reasons what-so-ever the contractor is unable to keep the delivery schedule of the contractee, extension of time may be granted by the contractee at their discretion as may be necessary to the extent considered necessary should there be delay in supply beyond the extended date of delivery, it shall be open to the contractee to terminate the contract in part or full and make other arrangements for executing fabrication elsewhere at the cost and risk of the contractor.

VJ Applicability of Integrity Pact

IP is a tool to ensure that activities and transactions between the company and its Bidders/ Contractors are handled in a fair, transparent and corruption free manner. Following Independent External Monitors (IEMs) on the present panel have been appointed by BHEL with the approval of CVO to oversee implementation of IP in BHEL.

The IP as enclosed with the tender is to be submitted (duly signed by authorized signatory who signs in the offer) along with techno-commercial bid. Only those bidders who have entered into such an IP with BHEL would be competed to participate in the bidding. In other words, entering into pact would be a preliminary qualification.

Sl no	IEM	Email
1	Shri Otem Dai, IAS (Retd.)	iem1@bhel.in
2	Shri Bishwamitra Pandey, IRAS (Retd.)	iem2@bhel.in
3	Shri Mukesh Mittal, IRS (Retd.)	iem3@bhel.in

Please refer section-8 of the IP for Role and Responsibilities of IEMs. In case of any complaint arising out of the tendering process, the matter may be referred to any of the above IEM(s). All correspondence with IEMs shall be done through email only.

No routine correspondence shall be addressed to the IEM (phone / post/ email) regarding the clarifications, time extensions or any other administrative queries, etc. on the tender issued. All such clarification/issues shall be addressed directly to the tender issuing (procurement) department's officials whose contact details are provided below

Name: B.Sivasubramanian Sr.Manager & S.Srinivasan, Exe.Addl.Engr II
Deptt: Outsourcing
Address: BHEL, Ranipet
Phone: (Landline/ Mobile) 04172-284030/284158/ 9442586376 & 9442308554
e-mail: *b smanian@bhel.in & ssvasan@bhel.in*

Integrity Pact are applicable for all the BHEL enquiries whose estimated value is equal to or more than Rupees 02 Crores.

Format of Integrity Pact as per annexure H is attached along with the tender documents for ready reference.

WJ Fraud Prevention Policy:

The Bidder along with its associate/ collaborators/ sub-contractors/ sub-vendors/ consultants/ service providers shall strictly adhere to BHEL Fraud Prevention Policy displayed on **BHEL website <http://www.bhel.com>** and shall immediately bring to the notice of BHEL Management about any fraud or suspected fraud as soon as it comes to their notice.

As per BHEL's Fraud prevention Policy, Nodal officers were nominated by BHEL Management. The details of such Nodal officers are furnished below:



Name shri/smt	Designation	Email ID	Phone No
Manimala K P	GM-OS & WCM	manimala@bhel.in	04172-28 4050
Ashok K	GM-,SOM , PMS & DTG	apa @bhel.in	04172-28 4607
Ravikumar P	GM- OPERATIONS	pravi @bhel.in	04172-28 4574
Saravanan G A	GM- MM,Marketing & NGA	saravananga@bhel.in	04172-28 4446
Sivaprakasam P	GM-ENGINEERING	sprakasam@bhel.in	04172- 28 4964
Suresh Kumar P	GM – Coml ,RM & Shipping	psureshkumar @bhel.in	04172-28 4300
Vijayalakshmi K G	GM-Finance	kgviji@bhel.in	04172- 28 4518
Umapathi N K	SDGM-VIGILENCE	umapathi@bhel.in	04172-28 4463

Any bidder / contractor who come across any fraudulent behaviour of BHEL's employees may communicate the same to any / all of these Nodal officers.

X] Others

- a) The Firms are advised to study and understand the scope of work and the entire process of Contract execution involved before quoting. Any technical clarifications required can be sought in person or by e-mail one week before the due date of Tender opening.
- b) In case of any contradiction in the terms and conditions given here and elsewhere in the other documents of the tender or any omissions in the Tender documents or for any clarifications in the tender conditions, it shall be the responsibility of the tenderer to get it clarified from BHEL. The officer authorized to provide such clarifications is the Manager / Contracts, Outsourcing Department, Phone: 04172 – 284030, e-mail bsmanian@bhel.in, ssvasan@bhel.in
- c) Alterations to the conditions of the Tender can be done only by the authorized officer, at any time before the date and time of tender opening. Such changes, if any, would be communicated in writing and / or hosted in the web-page.
- d) BHEL will conclude that the offer has been submitted by the firm fully understanding all the requirements both explicit and implied and other conditions and accepting the same. After tender opening, the bidders are not allowed to change / alter any of the conditions either partly or fully. Offers of any such firms doing so, will be rejected.
- e) Conditional and late Tenders, Tenders which are incomplete or otherwise considered defective with respect to Tender conditions and Tenders not in accordance with the Tender conditions herein contained and the Tenders not in original shall be rejected out rightly, at any point of time during the Tender processing.
- f) Should the tenderer or the contractor have a relation or relations in the case of a firm or company of contractors, one or more of its shareholders or relations or relations of the share holders employed in BHEL or any ex-employee who has retired / resigned within a period of two years as on date of quotations or at any subsequent date after the award of the contract, the authority inviting the Tender shall be informed of the fact at the time of submission of the tender and there after as applicable and obtain the clearance of BHEL for such engagement failing which, BHEL may in its own discretion reject the tender or rescind the contract.



- g) If a Bidder is found to have given false information / documents as a part of their offer, such offers shall be rejected / the contract shall be terminated and the firm shall be banned from getting business from all BHEL units.
- h) If any Supplier attempts to bribe, or pay commission, gift or any advantage or bring in undue influence either by himself or on his behalf any one including a stranger to the tender, in addition to instituting legal proceedings as per the extant laws prevailing, will disqualify the supplier from this tender and all future tenders of BHEL. Decision of the Purchaser would be final in this matter.
- i) The laws governing this transaction shall be the laws in India.
- j) The tenderer shall acquaint himself with the conditions/limitations and official regulations under which or conforming to which the jobs are to be performed and shall examine carefully at the information as may be furnished to them in writing from time to time.
- k) The tenderer shall acquaint himself with applicable Acts.
- l) As a policy BHEL is not registering any power of attorney issued by Contractors/Contractors in favour of their bank for the collection of Invoice amounts on behalf of Contractors/Contractors and merely because BHEL had acted upon any such request by the party or their bankers does not constitute any legal right or binding on BHEL for any acts of omissions and commissions or failure to act upon it or for any payment made directly to the party. If any banker includes BHEL also as a party to any such dispute between the banker and the party, All legal and incidental expenses thereof will be recovered from the concerned parties only.
- m) In the event of an order, Supplier shall agree to settlement of disputes or differences, if any, by way of arbitration, in accordance with the "Rule of Arbitration" of the Indian Council of Arbitration.
- n) The offer/s of such of those bidders who do not accept for levy of liquidated damages (LD) for delay in delivery and who do not accept for submission of the BG for the value and period specified herein above is likely to be summarily rejected. No correspondence would be entertained by BHEL in this regard, on this subject. BHEL specifically draws the need of this mandatory requirement to the notice of all Bidders. The Price Bid of such of those offerers failing to meet this requirement, would not be considered for the Price-Bid Opening.*
- o) The language in the tender downloaded by the Bidders shall at no point of time be changed, altered or modified in any manner by the Tenderer. If such changes are made by any tenderer, it shall be considered as tampering with BHEL's specifications and the offer shall be summarily rejected, whenever it is noticed by BHEL. Such Bidders would be disqualified from the Bidding Process and their offers would be forfeited / Bank Guarantees invoked. They would not be allowed to participate in future tenders of BHEL.*

Y] General :

1.0 Definitions : Throughout these conditions and in the specifications the terms :

- (a) **"The Contractee"** means the Bharat Heavy Electricals Limited, acting through the Additional General Manager, Outsourcing Department ,Boiler Auxiliaries Plant, Ranipet – 632 406 unless the context otherwise provides.
- (b) **"The Contractor"** means the person, firm or company with whom the order for machining / fabrication is placed and shall be deemed to include the Contractor's successor (approved by the Contractee), representatives, heirs, executors and administrators, as the case may be, unless excluded by the terms of the Contract.
- (c) **"The Drawings"** means the drawings exhibited or provided for the guidance of the Contractor.

2.0 Execution :

The whole contract is to be executed in the most approved substantial and workman like manner to the entire satisfaction of the contractee, or the inspecting officer, who shall have power to reject any of the



fabrication of which he may disapprove; and his decision thereon and on any question as to the true intent and meaning of the specifications of drawings or of the work necessary for the proper completion of the contract, shall be final and conclusive. The contractee may require alterations if any to be made during the progress of machining /fabrication, and should these alterations be such that either partly to the contract considers an alteration in the changes justified such alteration shall not be carried out until amended cost of machining /fabrication charges have been submitted by contractor and accepted to fabricate without obtaining the consent of the contractee in writing to an amended cost of machining /fabrication charges, the contractor shall be deemed to have agreed to execute fabrication at such charges as may be considered reasonable by the contractee.

3.0 Interpretation :

Any dispute or difference of opinion in respect of the interpretation, effect or application of this particular condition of the contract or of the amount recoverable here under from the contractor shall be decided by the contractee and the decision shall be final and conclusive.

4.0 Book Examination Clause :

(a) The contractor shall, whenever required, produce or cause to be produced for examination by any officer of the contractee authorized in that behalf any cost or other account book or account voucher, receipt letter, memorandum, paper or writing or any copy of extract from any such document and also furnish information and returns verified in such a manner as may be required in any way relating to the execution of this contract or relevant for verifying, ascertaining, the cost of execution of this contract (the decision of such officer of the contractee on this question or relevancy of any document, information or return being final and binding on the parties). The obligation imposed by this clause is without prejudice to the obligation of the contract/Job-Work-Order or under any statutory rules or orders binding the contractor.

(b) The contractor shall, if the authorized officer of the contractee so requires (whether before or after the prices have been finally fixed), afford facilities to the officer of the contractee concerned to visit the contractor's works for the purpose of examining the process of manufacture and estimate of ascertaining the cost of production of the articles. If any portion of the work be carried out by a Contractor or any subsidiary or an allied firm or company, the authorized officer of the contractee shall have power to secure the books of such Contractor or any subsidiary or an allied firm or company shall be open to this inspection.

5.0 Set – Off Clauses :

BHEL shall have the right to recover any money which in the sole opinion or BHEL is due from the Contractor from any money due to the Contractor under this Contract or any other contract or from the Security Deposit furnished by the Contractor under this Contract or any other contract.

"For the sake of clarity, the phrases "from any money due to the contractor" and "from the Security Deposit furnished by the Contractor" shall include money due from and Security Deposit furnished to any other Unit/ Office of BHEL as the case may be".

6.0 Laws Governing the Contract :

(a) The contract shall be governed by the laws of Government of India in force.

(b) Irrespective of the place of execution of the contract, place of delivery, place of payment under the contract, the contract shall be deemed to have been made at Ranipet.

7.0 The Global Compact :

Global compact is a signature initiative of United Nations Security General and four United Nation Agencies

- Office of the High Commissioner for Human rights
- International Labour Organization



- United Nations Environment Programme
- United Nations Development programme

This is a board based initiative and engages:

- Individual Companies
- Business Associations
- International Labour
- Human Rights, Environment and development Organisations
- Academic & Public Policy Instructions and United Nations

The Contractee (BHEL) is a member of this Global Compact. As a participating Company, We have the obligation to

- ** Support and respect Human rights with in our spheres of influence.
- ** Make sure we are not complicit in Human right abuses.
- ** Make sure we are not employing forced or compulsory labour.
- ** Refrain from employing child labour
- ** Eliminate discrimination in our hiring and firing policies
- ** Support a precautionary approach to Health, Safety of employees and society and environmental challenges.
- ** Undertake initiatives to promote greater environmental responsibility
- ** Encourage development and diffusion of environmentally friendly technologies.

Contractor shall also ensure to fall in line with the above principles.

8.0 Occupational Health and Safety Management System (ISO 45001) and Environmental Management System (EMS 14001)

BHEL/BAP/RANIPET got accreditation Occupational Health and Safety Management System (ISO 45001) and Environmental Management System (ISO 14001). As per this, OS Contractors are requested to meet the requirements of EHS (Environmental Health & Safety) guidelines (mentioned below), while engaging and using Vehicles for incoming/outgoing transportation.

- To have valid Driving licence and RC book for the Transports
- To load the vehicle/bullock cart within the Safe Working Load (S.W.L.) The S.W.L. is to be displayed/painted on the vehicle/bullock cart.
- To load the material in such a way that it should not project outside the dimensions of the Vehicle/bullock cart.
- To stack the material in a manner that the material should not slide/fall during transportation.
- During manual lifting with an Adult, the weight should not exceed 50 kg.
- To attempt to adopt ISO 45001 / ISO 14001 requirements in their manufacturing process at Contractor's work place.
- To comply with applicable provisions of the Central Motor Vehicles Rules 1989 (Rule:136 and if any). List of important Phone Nos: (given by OS) should be available with the driver while transporting BHEL materials.
- To train drivers to handle emergency situation during transportation.
- To follow the Various Acts/Rules and Regulations (particulary Factories Act 1948 and Tamil Nadu Factory Rules 1950) applicable to them.
- To maintain valid PUC (Pollution Under Control) certificates and produce while vehicle is in this company premises.



Contractors are requested to meet the requirements of ISO 45001 / ISO 14001 as given below:

- ** To adopt ISO 45001 / ISO 14001 requirements in their manufacturing process at Contractor's work place.
- ** To comply with applicable provisions of the Central Motor Vehicles Rules 1989 (Rule: 136 and if any).
- ** To follow the applicable Acts/Rules and Regulations (like Factories Act 1948 and Tamil Nadu Factory Rules – 1950) applicable to them.
- ** In addition to this, they should follow the day to day communication of OS on this regard.

Special Note:

BHEL is a Government of India Undertaking. Its procurement practices are governed by the (Internal) Purchase Policy issued by the management of the company and as per the tender conditions applicable at the time of finalising the order against this tender.

Enquiry :652002E

Section V 54A Typical Drawing

1-78-244-04293
DRAWING NO.

ALL DIMENSIONS ARE IN MILLIMETRES

FOR PRODUCTION
REF.-PR:QA:590 FOR PAINTING
REF.-PR:QA:500 FOR UNTOL DIMNS.

SIZE OF WELD	ELECTRODE SPECN.
6	E 6013

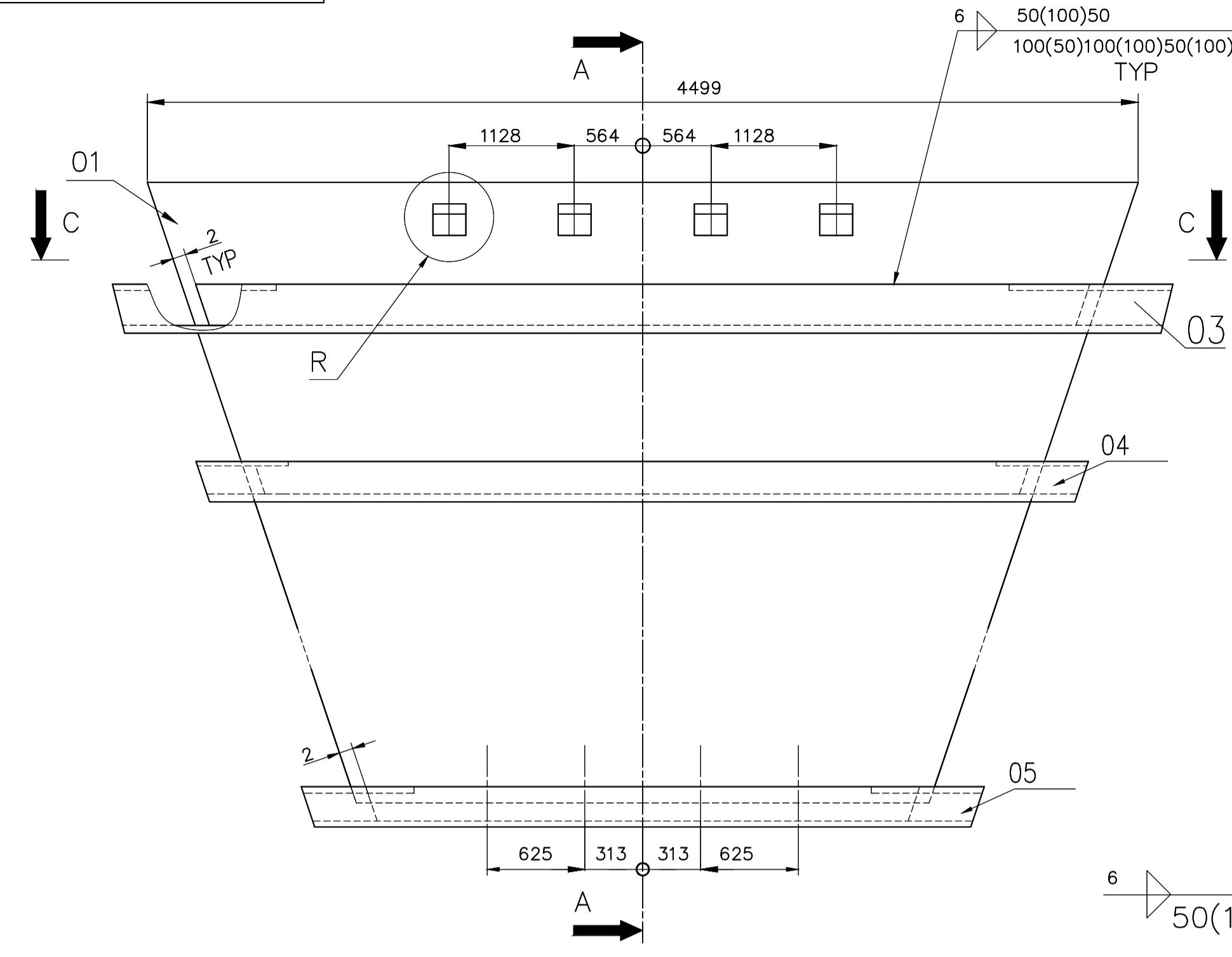

VARIANT - 01

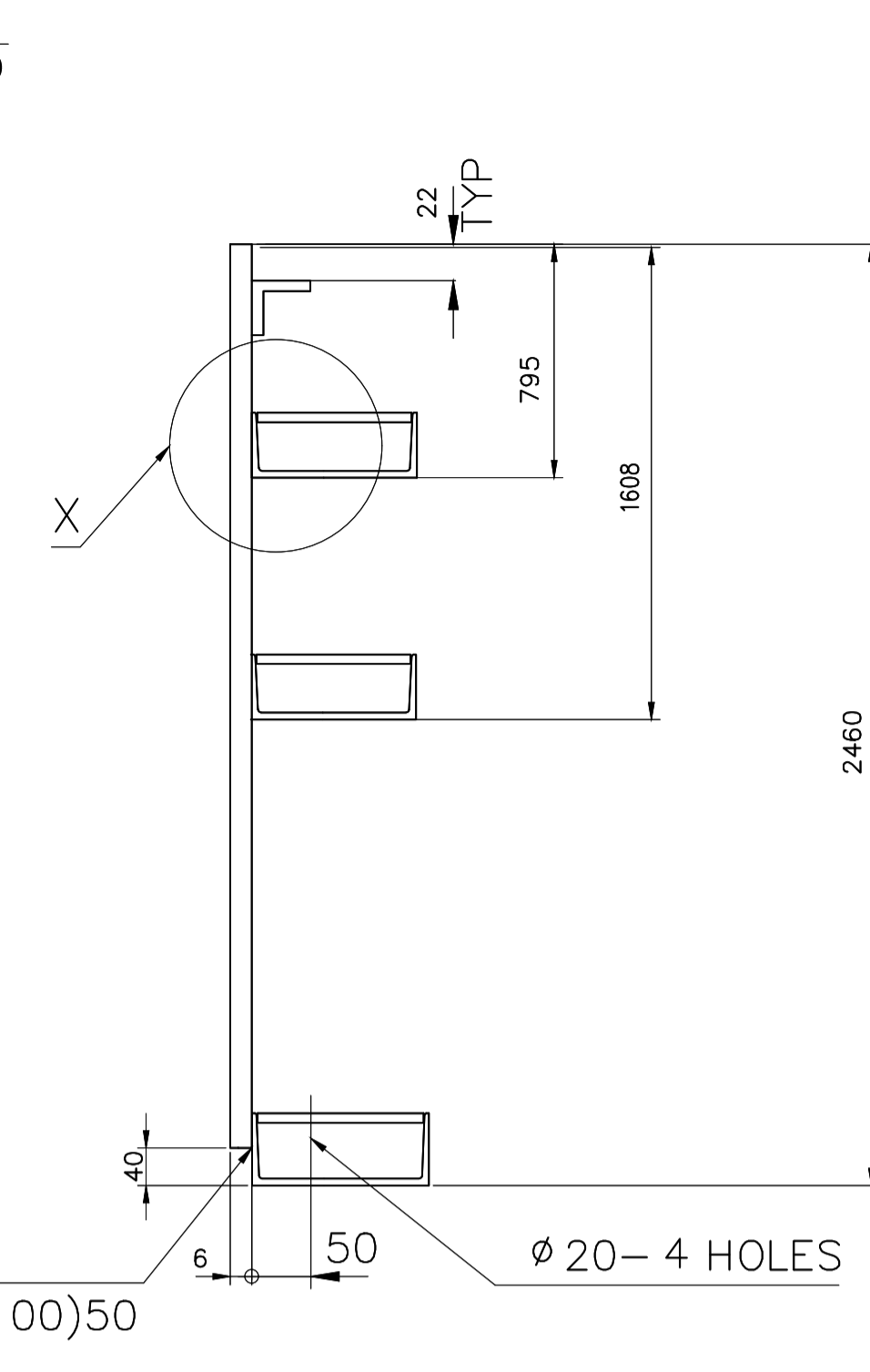

SECTION - AA

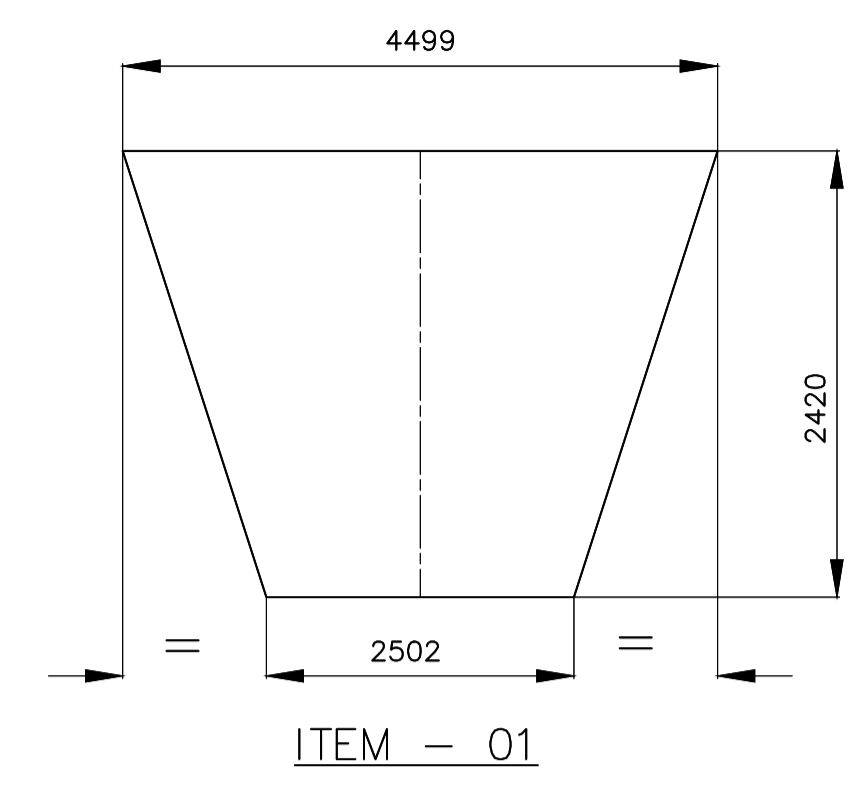

ITEM - 01

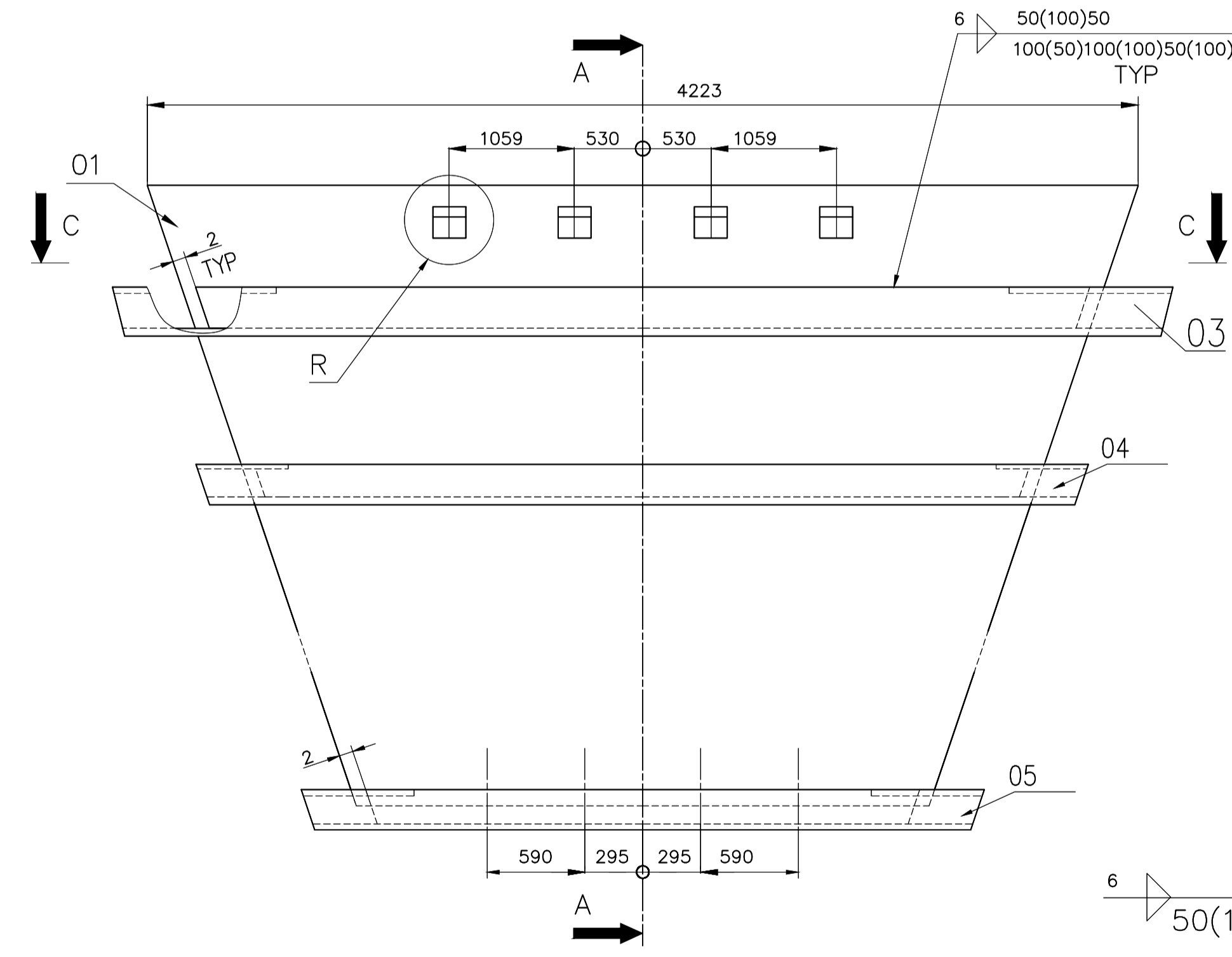

VARIANT - 02

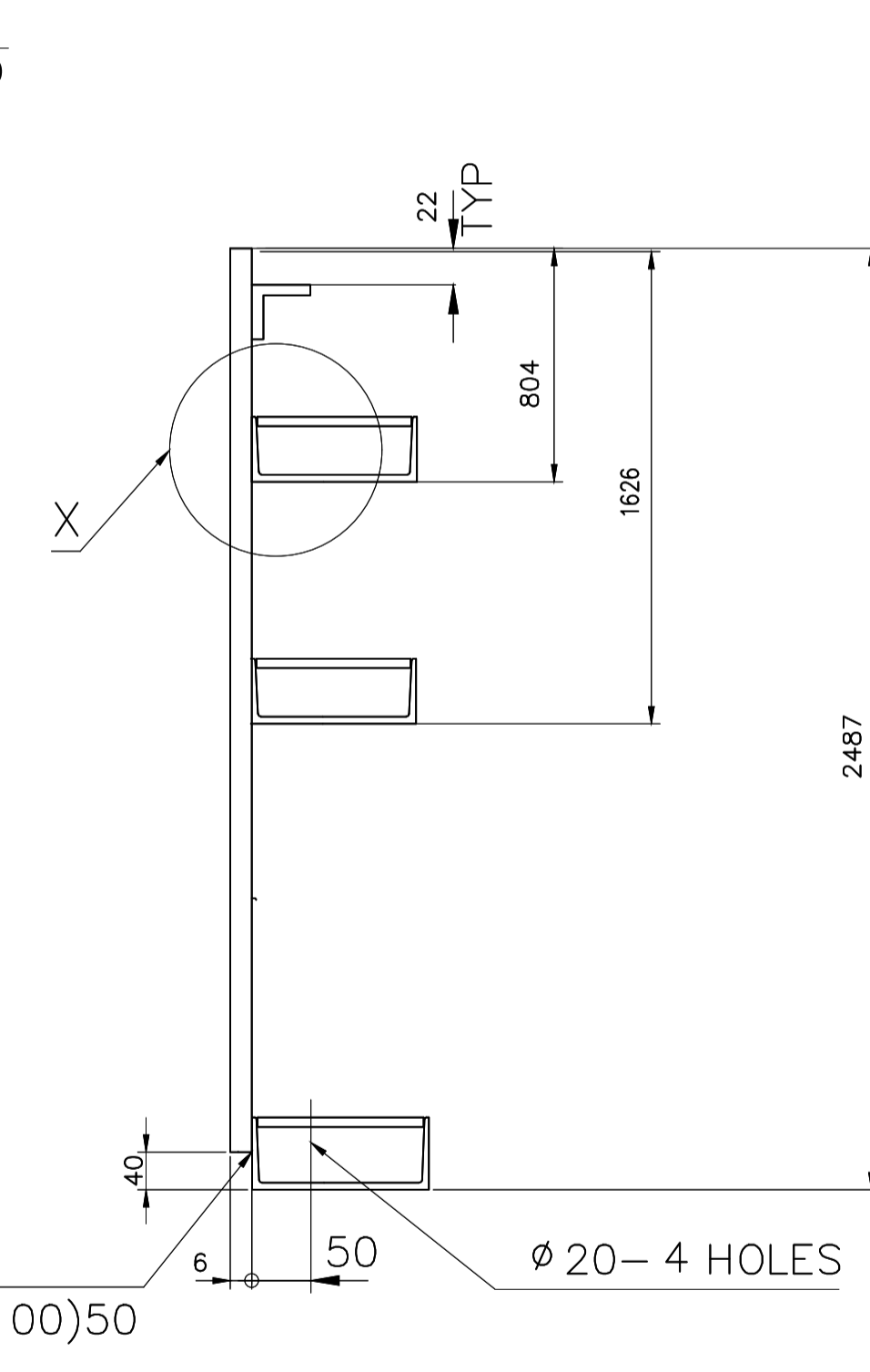

SECTION - AA

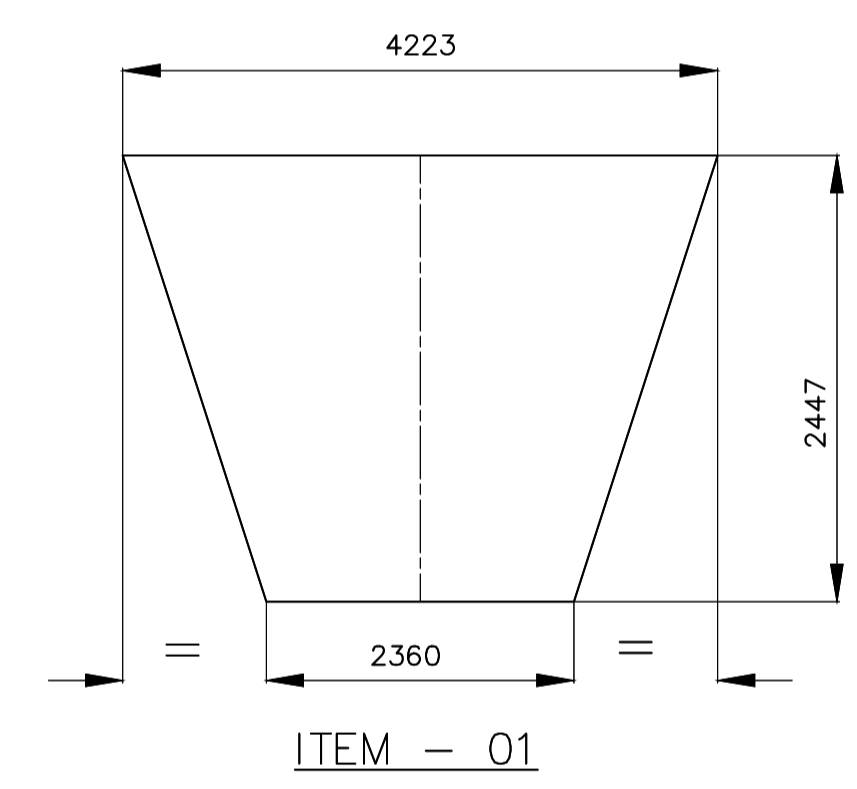

ITEM - 01

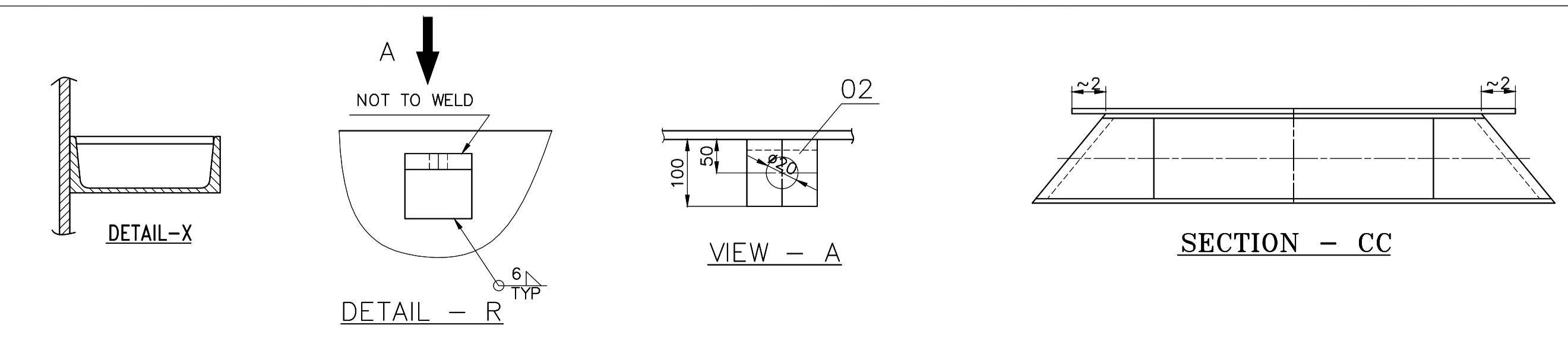

- NOTES**
- FOR FABRICATION TOLERANCE REFER -> PR:QA:500.
 - FOR MANUFACTURING REFER QCP : E : 002.

VAR NO	ITEM NO	DESCRIPTION	CAT	DRAWING No.	ITEM NO VAR	MATL SPECN MATL CODE	UNIT	QTY	UNIT WT	C.S	ZONE
02	05	STIFFENER CHANNEL I		1-78-244-04297	10				35.661		
02	04	STIFFENER CHANNEL I		1-78-244-04297	09				57.866		
02	03	STIFFENER CHANNEL I		1-78-244-04297	08				69.045		
02	02	ISA 100x100x10-100				150130180000			1.470		
02	01	PLATE 6X4223X2447				15011092			379.357		
01	05	STIFFENER CHANNEL I		1-78-244-04297	05				37.528		
01	04	STIFFENER CHANNEL I		1-78-244-04297	04				61.075		
01	03	STIFFENER CHANNEL I		1-78-244-04297	03				73.012		
01	02	ISA 100x100x10-100				150130180000			1.470		
01	01	PLATE 6X4499X2420				15011092			398.993		

CAUTION: The information on this drawing is the property of BHARAT HEAVY ELECTRICALS LTD. It must not be used directly or indirectly in any way without the prior approval of this company.

TYPE OF PRODUCT OR NAME OF CUSTOMER/PROJECT

BHARAT HEAVY ELECTRICALS LTD.,
UNIT: BOILER AUXILIARIES PLANT.
RANIPET - 632 406.

DRN	NAME	SIGN	DATE/NO. OF REV.
CHD	BV REDDY		5/15/2020
APPD	MK NAHAK		5/15/2020

DEPT: EDCS GRADE OF UNTOLO.DIM: PR:QA:500 SCALE: NTS WEIGHT (KG): REF. TO ASSY/OLD DRG. ITEM NO. OF THIS REV.

TITLE: **HOPPER MIDDLE WALL I** CARD CODE: U 01 DRAWING NO.: **1-78-244-04293** REV:

REV	DATE	ALTERED	CHECKED

TYP OF WELD.	ELECT. SPEECH.
5	E 6013

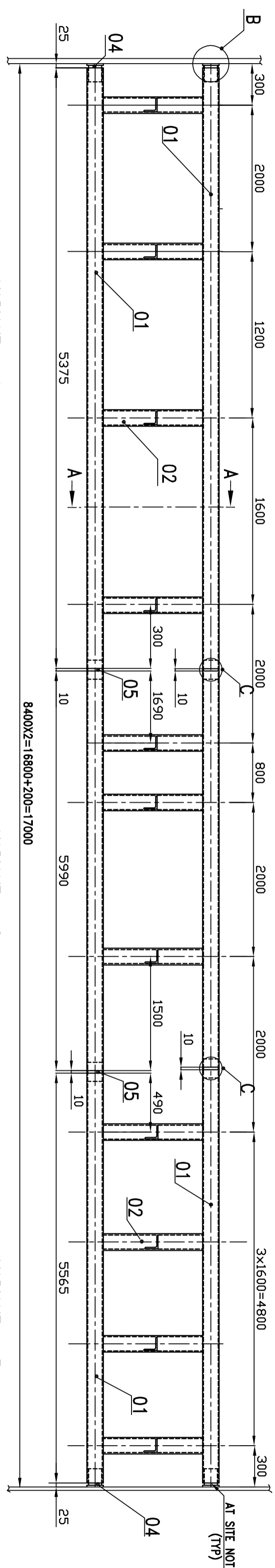

VARIANT - 1

VARIANT - 2

VARIANT - 3

NOTE:
 01. MAXIMUM DEVIATION ALLOWABLE FOR CENTRE LINE OF ITEMS 01 & 02 IS +0.5MM.
 02. STRAIGHT DEVIATION PERMITTED IS 1MM/M AND 2MM OVER TOTAL LENGTH.

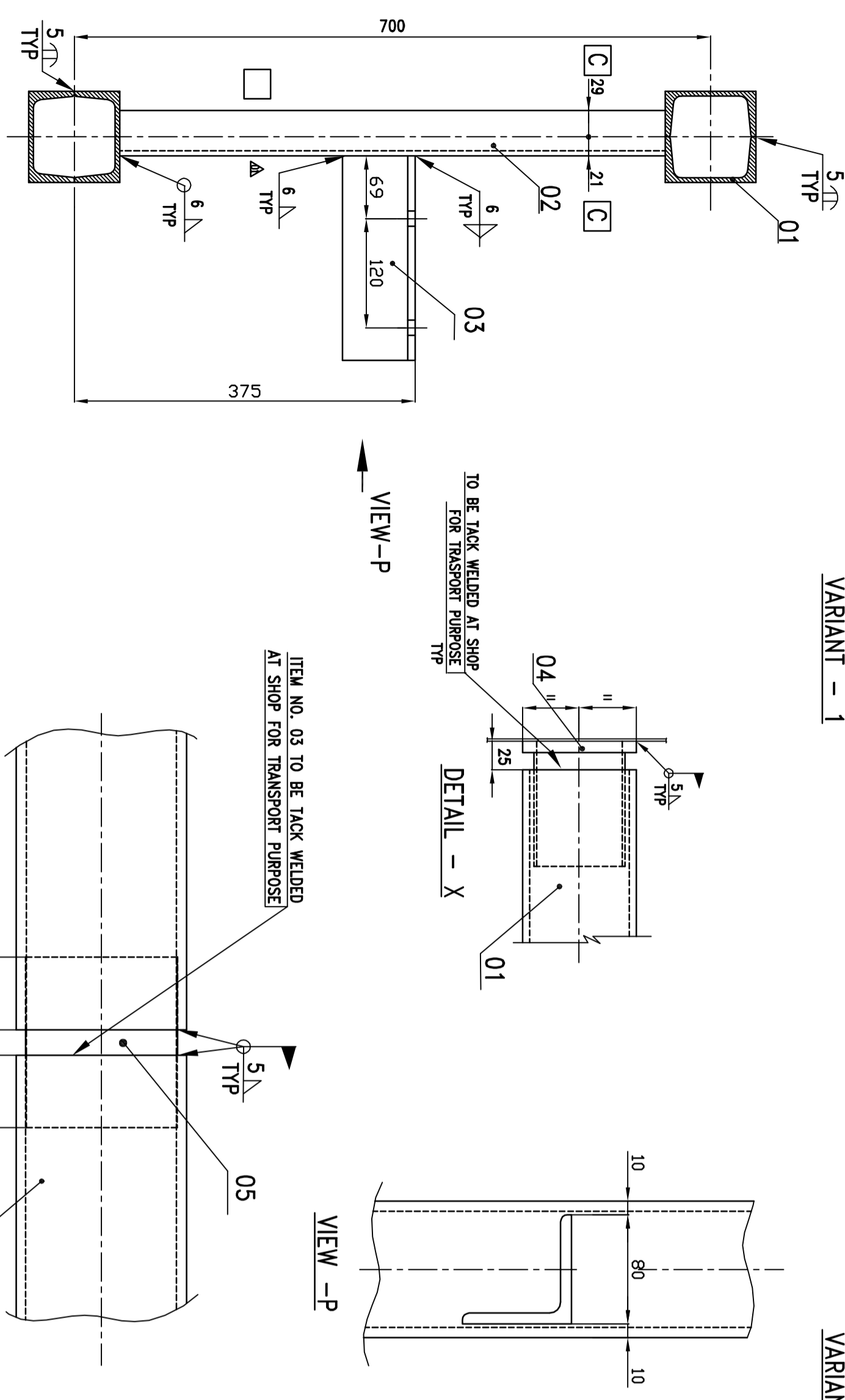

TO BE TACK WELDED AT SHOP FOR TRANSPORT PURPOSE TYP

ITEM NO. 03 TO BE TACK WELDED AT SHOP FOR TRANSPORT PURPOSE

SECTION - AA

VIEW - P

VIEW - P

DETAIL - Y

VAR. NO.	WEIGHT
01	241.030
02	257.405
02	248.294

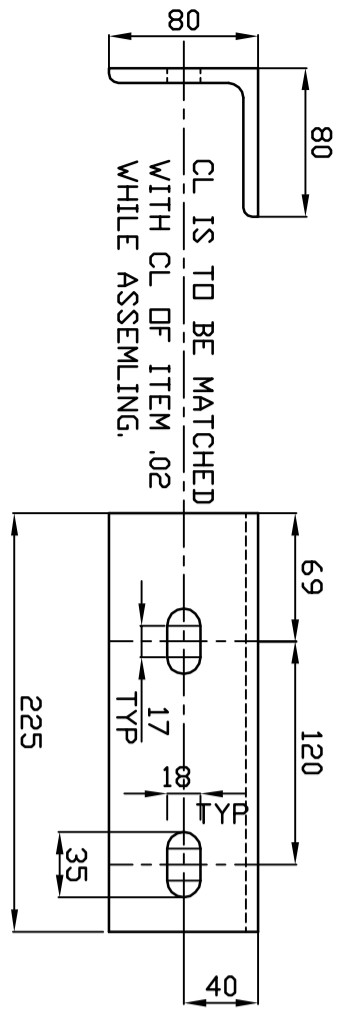

ITEM NO 03

VAR. NO.	ITEM NO.	DESCRIPTION	DRAWING NO.	ITEM NO.	VAR. NO.	MATL. CODE	MATL. SPECN	UNIT	WT.	QTY.	REMARKS
03	04	PLUG	6172-0120						1.955	2	
03	03	ISA 80X80X8:225							2.160	4	
03	02	ISMC 100:600							5.735	4	
03	01	ISMC 100-5565							53.201	4	
02	05	TUBE	6172-0121						1.170	4	
02	03	ISA 80X80X8:225							2.160	3	
02	02	ISMC 100:600							5.735	3	
02	01	ISMC 100-5990							57.260	3	
01	04	PLUG	6172-0120						1.955	4	
01	03	ISA 80X80X8:225							2.160	2	
01	02	ISMC 100:600							5.735	4	
01	01	ISMC 100-5375							51.385	4	

CAUTION: The information on this document is the property of BHARAT HEAVY ELECTRICALS LTD. It must not be used directly or indirectly in any way detrimental to the interest of the company.

TYPE OF PRODUCT OR NAME OF CUSTOMER/PROJECT		BHARAT HEAVY ELECTRICALS LTD. UNIT. BOILER AUXILIARIES PLANT. RANIBET - 632 406.	
DEPT. ACOS	GRADE OF UNTOLO DIM	SCALE	WEIGHT (KG)
C / M / F		N T S	*
REV. DATE	ALTERED	CHECKED	DATE
01 01/07/2016	A.PALANI	C.GANESH	19/02/2015
ZONE			
TITLE		CARD CODE	DRAWING NO.
BRACKET ASSY. (400 mm PITCH)		U 01	2-79-825-06137
			01

DRAWING NO.

ALL DIMENSIONS ARE IN MILLIMETRES

FOR PRODUCTION
REF.-PR:QA:590 FOR PAINTING
REF.-PR:QA:500 FOR UNTOL. DIMNS.

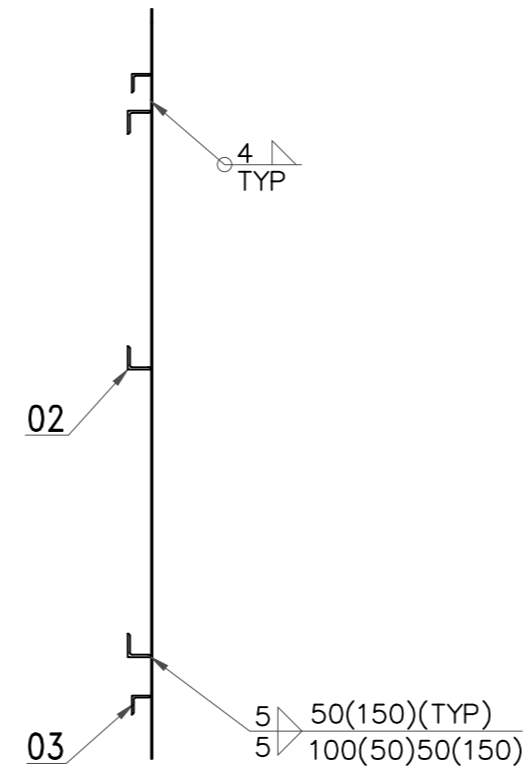
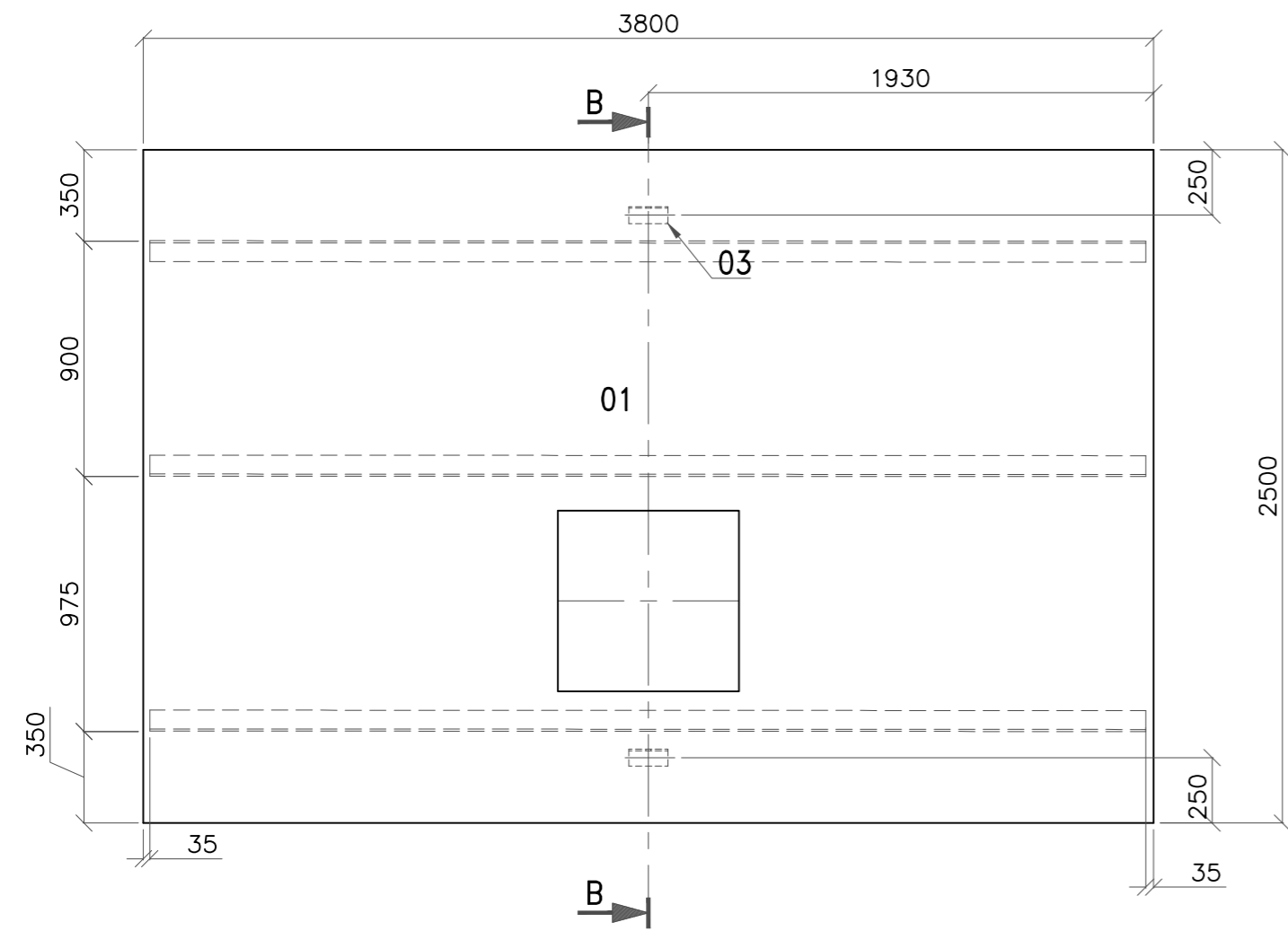

SECTION BB

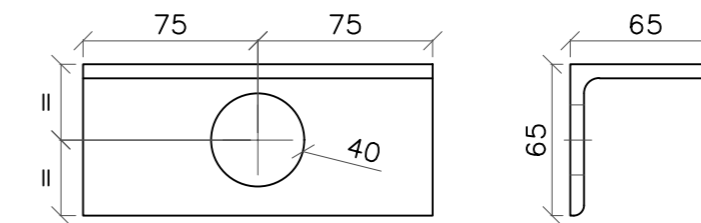
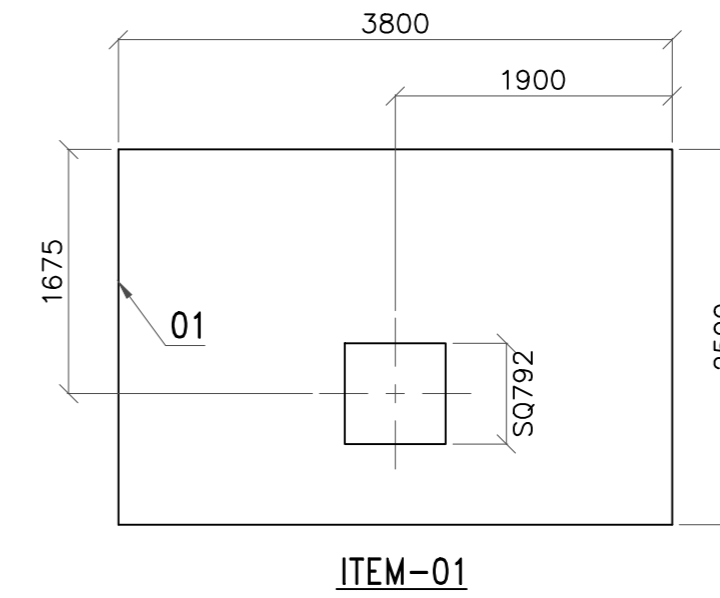

ITEM-03

VARIANT NO	ITEM NO	DESCRIPTION	STD	DRAWING NO.	ITEM NO	MATL. CODE	A	UNIT	UNIT WT.	CS	ZONE
					VAR NO	MATL. SPEC	C	DI	QUANTITY		
	03	LIFTING ANGLE ISA 65X65X6-150				AA1012508099			0.870		
						IS 2062			2		
	02	ISA 80x80x8-11190				AA1012508161			107.424		
						IS 2062			1		
	01	CH PL 5x3800x2500				150111810000			402.378		
						IS 2062			1		

TYPE OF PRODUCT
OR NAME OF
CUSTOMER/PROJECT

BHARAT HEAVY ELECTRICALS LTD.
UNIT: BOILER AUXILIARIES PLANT.
RANIPET - 632 406.

DRN	P.PUGAZH	SIGN	DATE	NO.OF
CHD	R.ARUN MANTICKAM		19.07.18	VAR.
APPD	C. GANESH			2

DEPT	AQCS	GRADE OF	SCALE	WEIGHT (KG).	REF. TO ASSY/OLD DRG.	ITEM NO.	NO. OF
CODE	862	UNTOL. DIM	N.T.S	511.542		-	ITEMS
TITLE	OUTER ROOF PANEL - XI				CARD	DRAWING NO.	REV
				U 01	2-79-842-07551	00	

REV	DATE	ALTERED
ZONE		CHECKED

CAUTION: The information on this document is the property of BHARAT HEAVY ELECTRICALS LTD. It must not be used directly or indirectly in any way detrimental to the interest of the company.

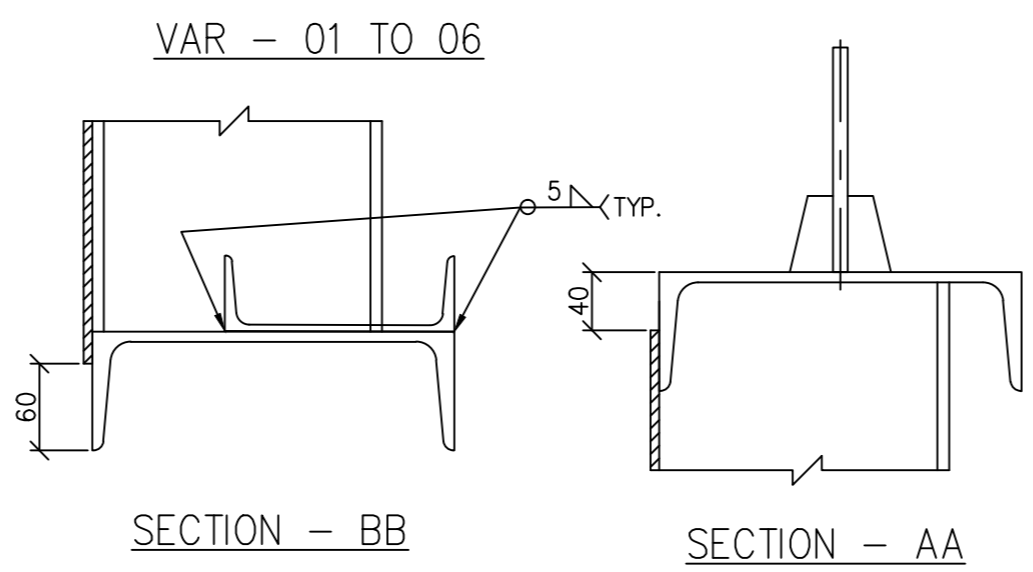
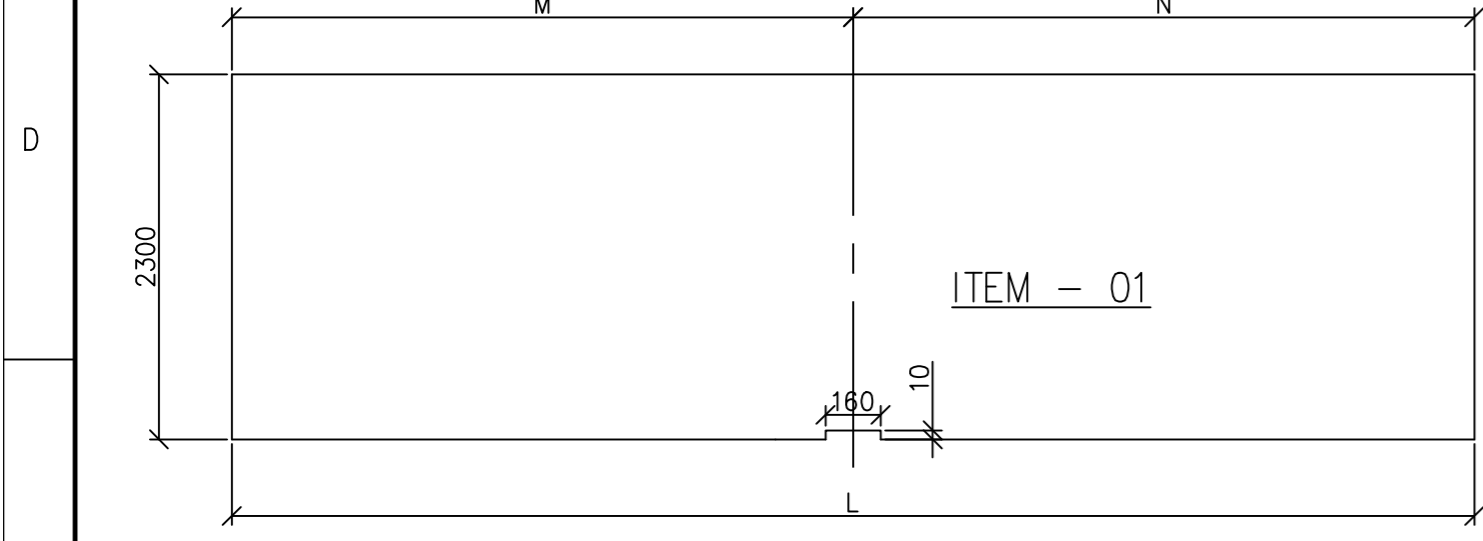
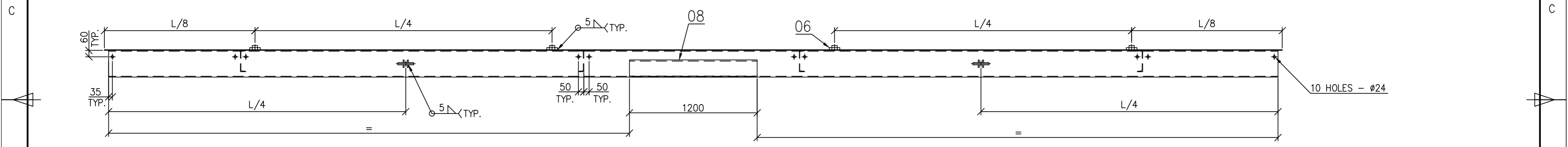
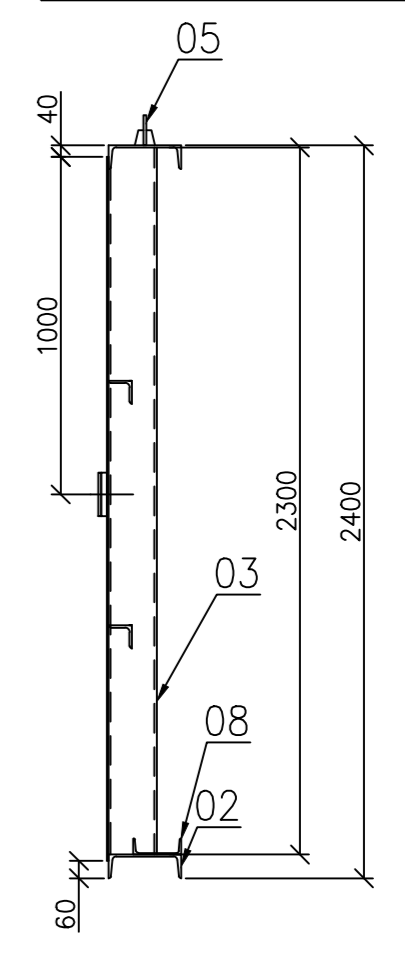
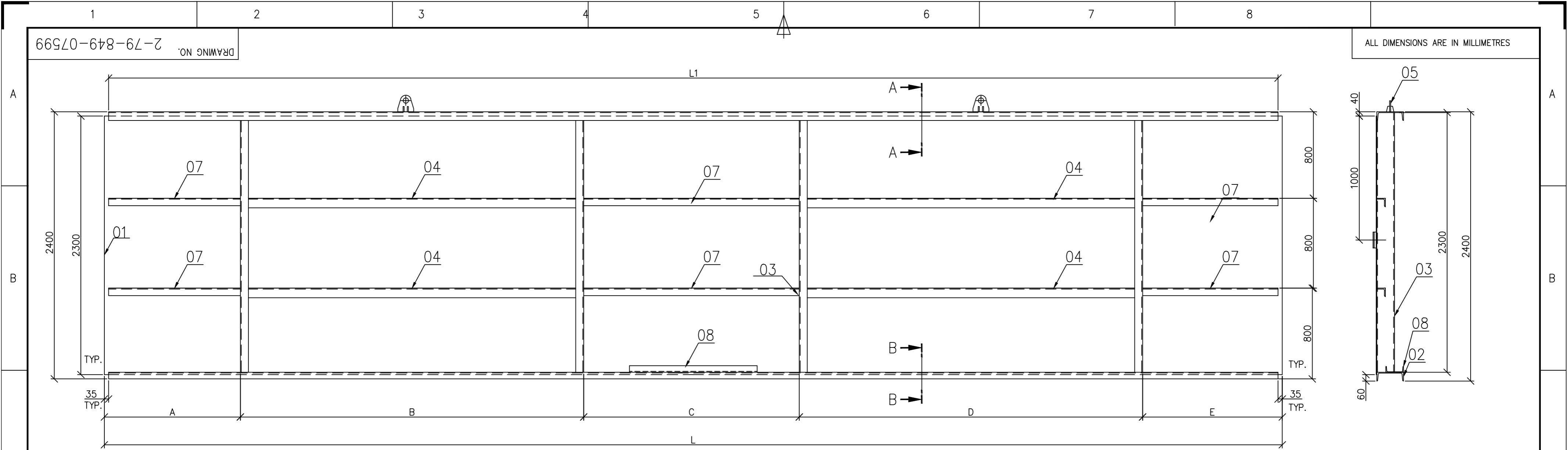

VAR No.	ITEM No.	DESCRIPTION	STD	DRAWING NO.	ITEM No. VAR No.	MATL. CODE	A UNIT	UNIT WT.	G.S.	ZONE
	08	MC100-1200				AA1012708039		11.472		
						IS 2062 Gr. A		1		
	07	EA75x75x6				AA1012508129	MR	6.800		
						IS 2062 Gr. A		RM2		
	06	SUPPORT LUG	6172-0140			942851580000		0.886		
								4		
	05	LIFTING EYE-50				942230050000		1.510		
						61810130		2		
	04	UEA125x75x8				AA1012608077	MR	12.1		
						IS 2062 Gr. A		RM1		
	03	MC300-2300				AA1012708179		83.490		
						IS 2062 Gr. A		4		
	02	MC300-L1				AA1012708179		WT1		
						IS 2062 Gr. A		2		
	01	PL6x2300xL				AA1011808030		WT		
						IS 2062 Gr. A		1		

NOTES: -
 FOR FABRICATION REFER RELEVANT QW.
TOLERANCE :
 LENGTH : +5MM
 DIAGONAL : +7MM
 CAMBER : 1MM/M MAX. 5MM
 SWEEP : 1MM/M MAX. 5MM
 FOR UNTOLERANCEDIMENSION REFER RELEVANT QW.
 FOR PAINTING REFER RELEVANT QW.
 FOR FAB/OTHER WELDING DETAILS REFER DRG.
 1-79-049-00550 & 00553.

VAR	A	B	C	D	E	L	L1	WT	WT1	Item 04 (B+D)*2 RM1	Item 07 (A+C+E)*2 RM2	TW	M	N
01	1270	3900	1850	3900	1267	12187	12117	1320.142	439.847	15.6	8.800	2800.432	6095	6092
02	817	3900	2300	3900	1267	12184	12114	1319.816	439.738	15.6	8.800	2799.888	6092	6092
03	817	3900	2300	3900	1270	12187	12117	1320.142	439.847	15.6	8.800	2360.585	6092	6095
04	1267	3900	1850	3900	1270	12187	12117	1320.142	439.847	15.6	8.800	2360.585	6092	6095
05	1267	3900	2300	3900	817	12184	12114	1319.816	439.738	15.6	8.800	2360.150	6092	6092
06	1270	3900	2300	3900	817	12187	12117	1320.142	439.847	15.6	8.800	2360.585	6095	6092

REV	DATE	ALTERED
01	31.01.19	K.VENKAT
		CHECKED TN

TYPE OF PRODUCT OR NAME OF CUSTOMER/PROJECT

BHARAT HEAVY ELECTRICALS LTD.,
 UNIT: BOILER AUXILIARIES PLANT.
 RANIPET - 632 406.

DEPT	AGCS	GRADE OF UNTO.LDIM	SCALE	WEIGHT (KG).	REF. TO ASSY/OLD DRG.	ITEM NO.	NO. OF ITEMS
862	PR: QA: 500		N.T.S	****	-	-	-

DRN: K.VENKAT, SIGN: C.GANESH, DATE: 14.09.18, NO. OF VAR: 06

TITLE: **TOP PANEL - I, II & IV RIGHT & LEFT**

CARD CODE: U 01, DRAWING NO.: 2-79-849-07599, REV: 01

DRAWING NO. 2-79-849-07602

ALL DIMENSIONS ARE IN MILLIMETRES

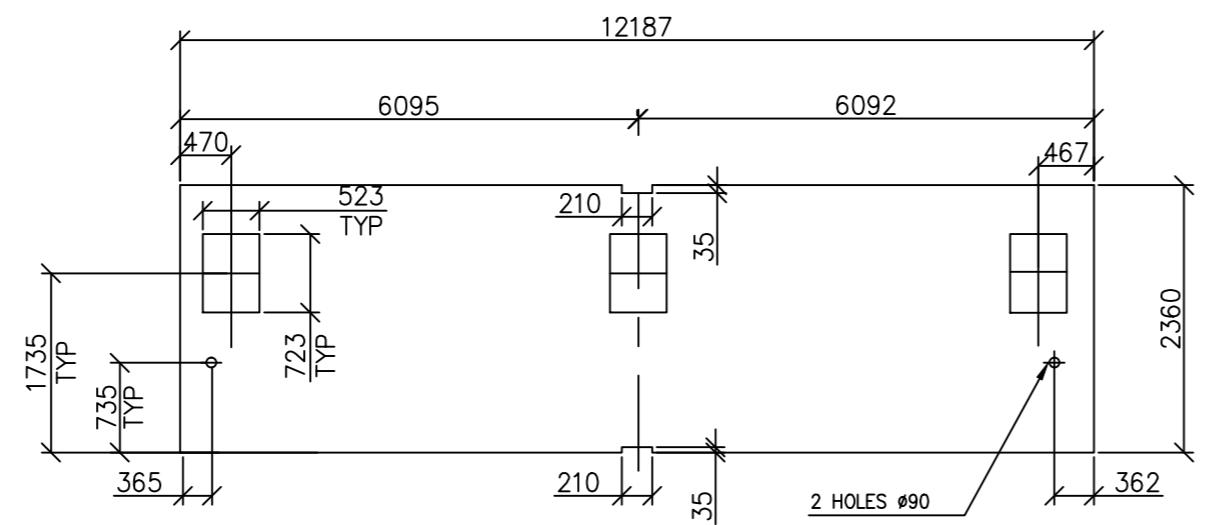
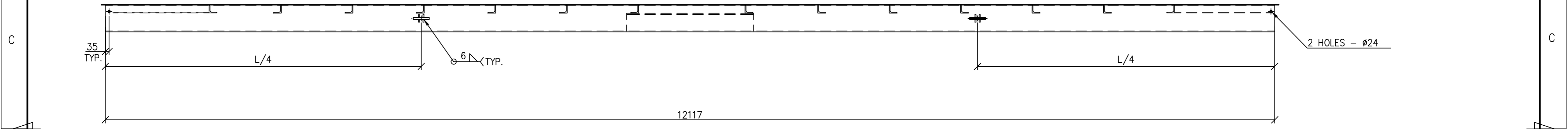
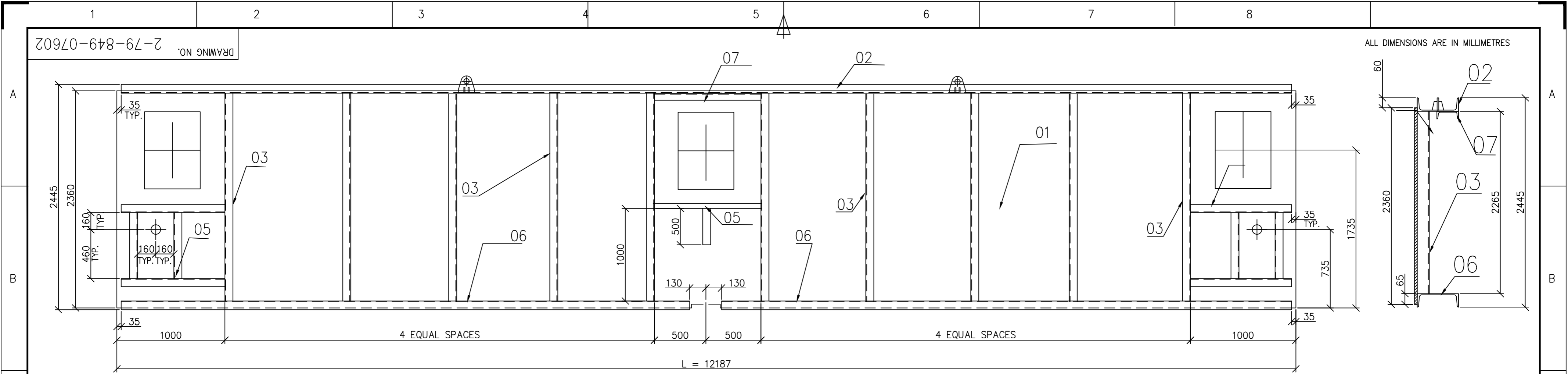

ITEM - 01

VAR No.	ITEM No.	DESCRIPTION	STD	DRAWING NO.	ITEM No.	MATL. CODE	A	UNIT	UNIT WT.	G.S.	ZONE
					VAR No.	MATL. SPEC	C	DI	QTY.		
	07	MC100-1200				AA1012708039 IS 2062 Gr. A			11.472 1		
	06	MC300-5928				AA1012708179 IS 2062 Gr. A			215.186 2		
	05	MC100 -RM				AA1012708039 IS 2062 Gr. A	MR		9.56 7.90		
	04	LIFTING EYE -D50				942230050000 61810130			1.510 2		
	03	EA100X50X8-2265				150131630100 IS 2062 Gr. A			20.362 10		
	02	MC300-12117				AA1012708179 IS 2062 Gr. A			439.847 1		
	01	PL5x2360x12187				AA1011808013 IS 2062 Gr. A		NO	1083.781 1		

NOTES: -
 FOR FABRICATION REFER RELEVANT QWI.
TOLERANCE :
 LENGTH : +5MM
 DIAGONAL : +7MM
 CAMBER : 1MM/M MAX. 5MM
 SWEEP : 1MM/M MAX. 5MM
 FOR UNTOLERANCEDIMENSION REFER RELEVANT QWI.
 FOR PAINTING REFER RELEVANT QWI.
 FOR FAB/OTHER WELDING DETAILS REFER DRG. 1-79-049-00550 & 00553.

TYPE OF PRODUCT OR NAME OF CUSTOMER/PROJECT

BHARAT HEAVY ELECTRICALS LTD.,
 UNIT: BOILER AUXILIARIES PLANT.
 RANIPET - 632 406.

DRN	K.VENKAT	SIGN	DATE	NO.OF VAR.
CHD	TNR		15.09.18	
APPD	C.GANESH		15.09.18	

DEPT	AQCS	GRADE OF UNTOL.DIM	SCALE	WEIGHT (KG)	REF. TO ASSY/OLD DRG.	ITEM NO.	NO. OF ITEMS
CODE	862	PR: QA: 500	N.T.S	*****	-	-	-

TITLE: **BOTTOM PANEL - I (RIGHT)**

CARD CODE: U 01

DRAWING NO. **2-79-849-07602**

REV **00**

REV	DATE	ALTERED	CHECKED

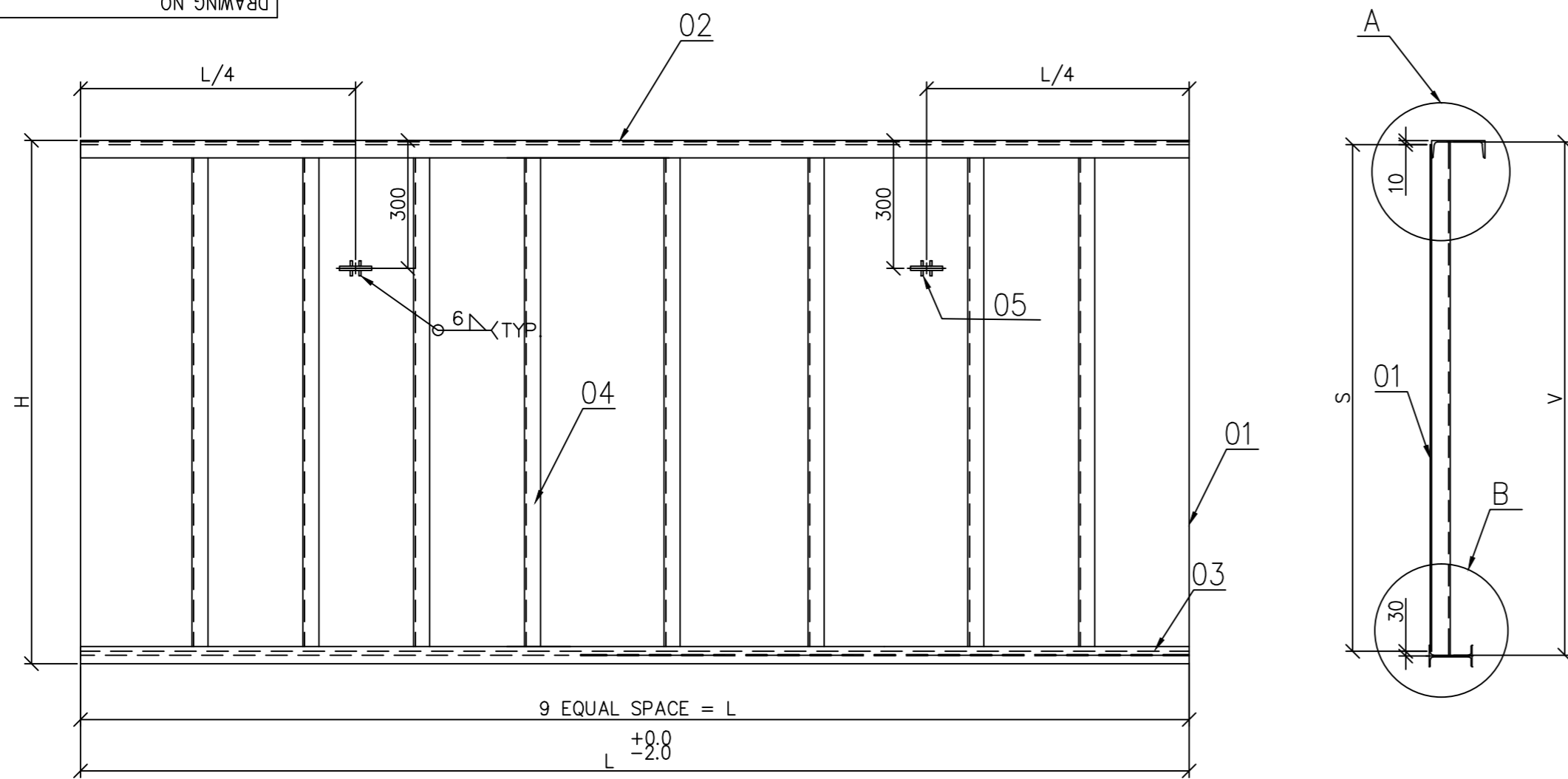

VAR. No. 01 & 02

VAR. No.	L	H	V	S	TW	GABLE BOTTOM
01	8748	950	895	860	****	INLET-BOTTOM
02	8701	2050	1995	1960	****	OUTLET-BOTTOM

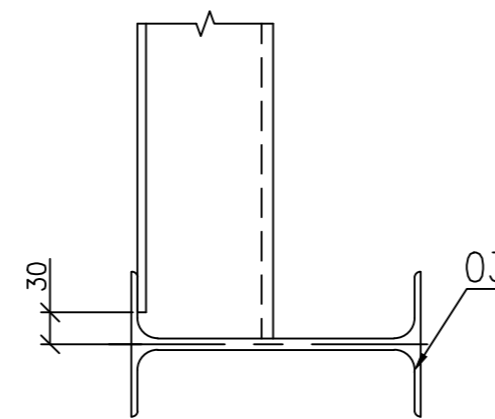

DETAIL - B

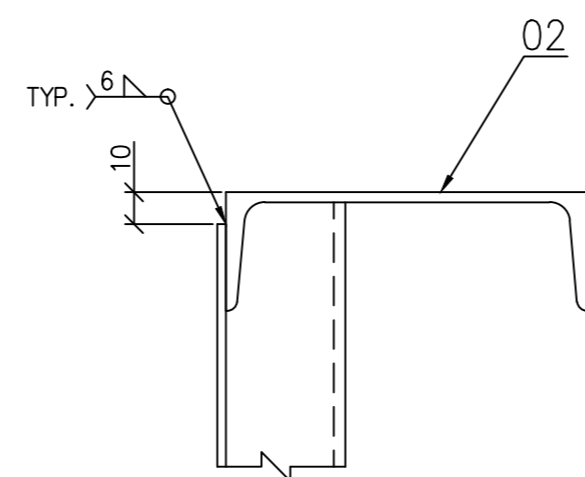

DETAIL - A

NOTES: -

1. FOR UNTOLERENCED DIMENSIONS REFER RELEVANT QWI.
2. FOR PAINTING REFER RELEVANT QWI.
3. FOR FABRICATION REFER RELEVANT QWI.
4. FOR WELDING USE E6013 ELECTRODE ONLY
5. FOR FAB/OTHER WELDING DETAILS REFER DRG. 1-79-049-00550 & 00553.

VAR No.	ITEM No.	DESCRIPTION	STD	DRAWING NO.	ITEM No.	MATL. CODE	A	UNIT	UNIT WT.	GS	ZONE
					VAR No.	MATL. SPEC	C	DI	QTY.		
02	05	LIFTING EYE - D50		61810130		942230050000			1.510		
									2		
02	04	ISA75X75X6-1995				AA1012508129			13.566		
						IS 2062 Gr. A			8		
02	03	MB200-8701				AA1012808092			210.564		
						IS 2062 Gr. A			1		
02	02	MC300-8701				AA1012708179			315.846		
						IS 2062 Gr. A			1		
02	01	PL5x1960x8701				AA1011808013			669.367		
						IS 2062 Gr. A			1		
01	05	LIFTING EYE - D50		61810130		942230050000			1.510		
									2		
01	04	ISA75X75X6-895				AA1012508129			6.086		
						IS 2062 Gr. A			8		
01	03	MB200-8748				AA1012808092			211.701		
						IS 2062 Gr. A			1		
01	02	MC300-8748				AA1012708179			317.552		
						IS 2062 Gr. A			1		
01	01	PL5x860x8748				AA1011808013			295.288		
						IS 2062 Gr. A			1		

TYPE OF PRODUCT OR NAME OF CUSTOMER/PROJECT		BHARAT HEAVY ELECTRICALS LTD., UNIT: BOILER AUXILIARIES PLANT. RANIPET - 632 406.		DRN K.VENKAT	SIGN	DATE 15.09.18	NO.OF VAR. 02
DEPT AQCS CODE 862	GRADE OF UNTOL.DIM PR: QA:500	SCALE N.T.S	WEIGHT (KG) TW	REF. TO ASSY/OLD DRG. -	ITEM NO. -	NO. OF ITEMS -	
TITLE GABLE BOTTOM (INLET & OUTLET)			CARD CODE U 01	DRAWING NO. 2-79-849-07609		REV 00	

CAUTION: The information on this document is the property of BHARAT HEAVY ELECTRICALS LTD. It must not be used directly or indirectly in any way detrimental to the interest of the company.

REV	DATE	ALTERED	CHECKED

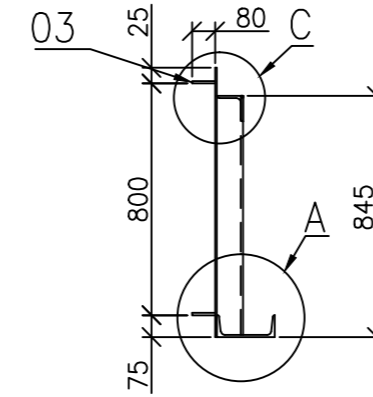
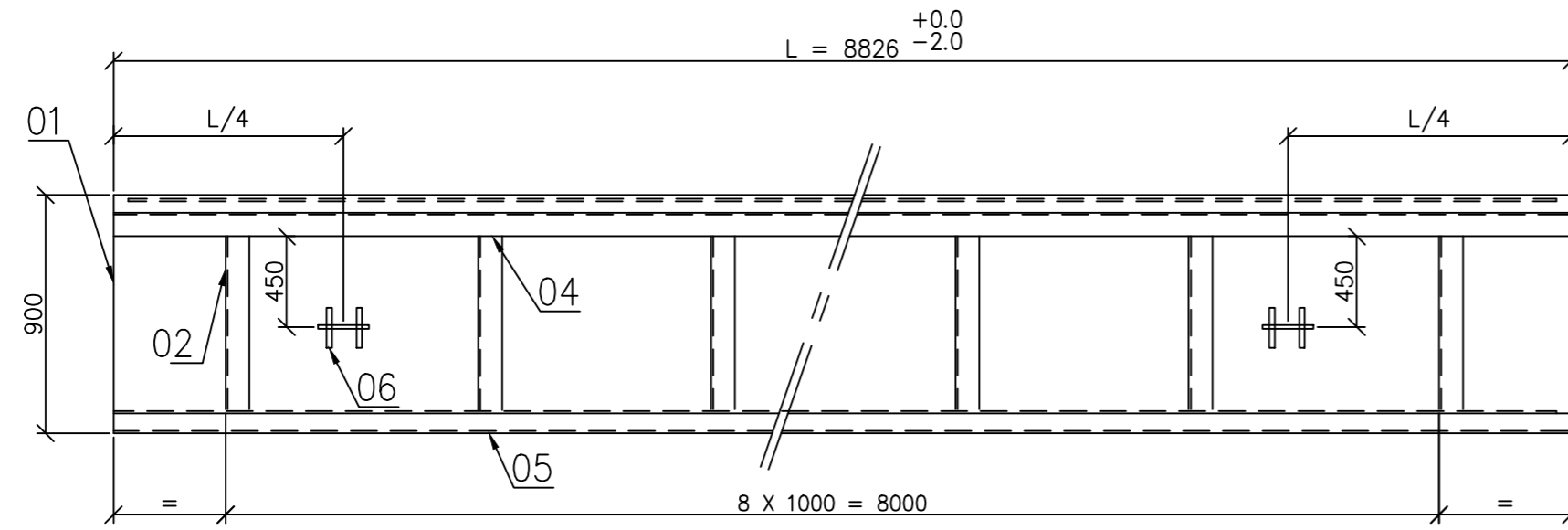

NOTES: -
 FOR FABRICATION REFER RELEVANT QWI.
TOLERANCE :
 LENGTH : +5MM
 DIAGONAL : +7MM
 CAMBER : 1MM/M MAX. 5MM
 SWEEP : 1MM/M MAX. 5MM
 FOR UNTOLERANCEDIMENSION REFER RELEVANT QWI.
 FOR PAINTING REFER RELEVANT QWI.
 FOR FAB/WELDING DETAILS REFER DRG. 1-79-049-00550 & 00553.

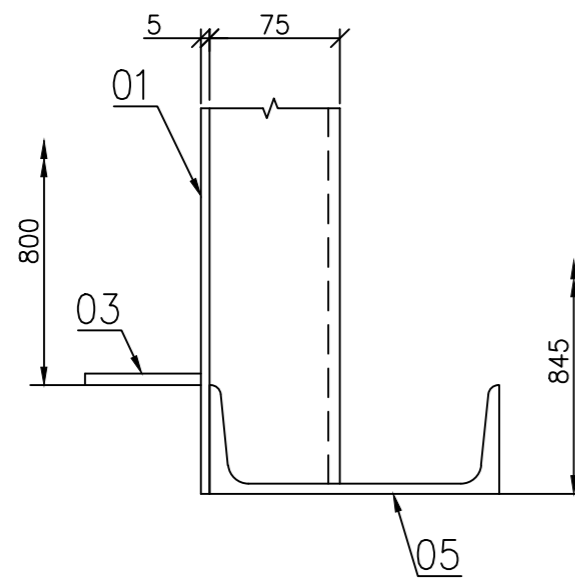
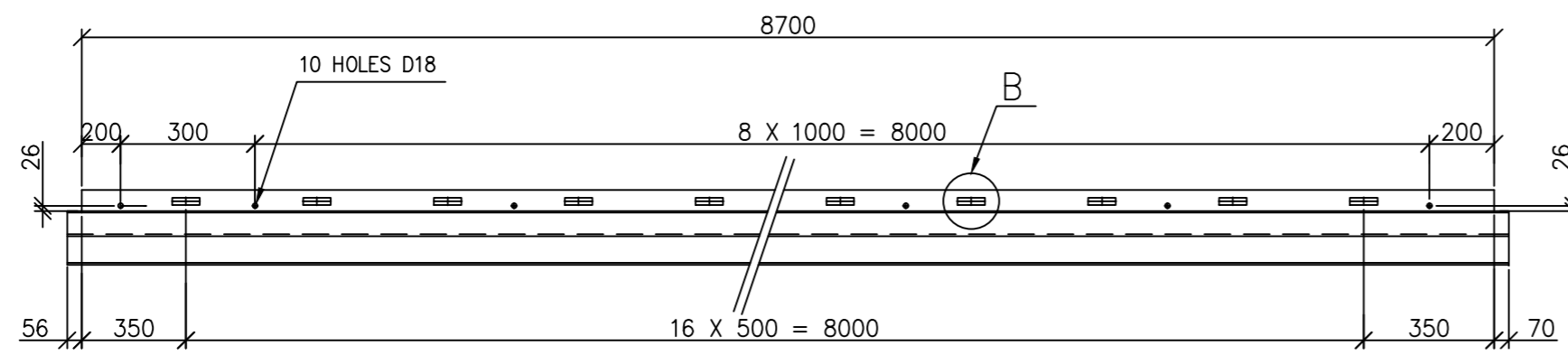

DETAIL - A

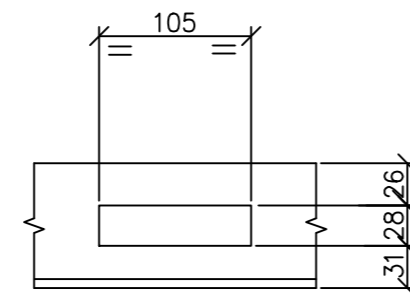

DETAIL - B

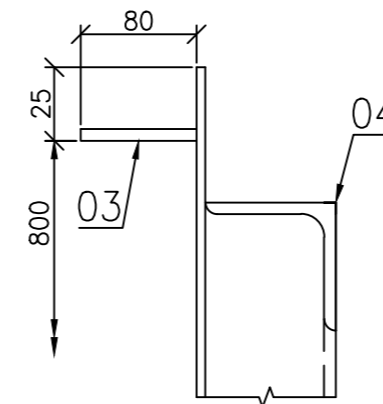

DETAIL - C

VAR No.	ITEM No.	DESCRIPTION	STD	DRAWING NO.	ITEM No. VAR No.	MATL. CODE	A UNIT	UNIT WT.	GS	ZONE
	06	LIFTING EYE - D50			942230050000			1.510		
					61810130			2		
	05	ISM 200 : 8826			AA1012708101			196.819		
					IS 2062 Gr. A			1		
	04	EA 75x75x6 ; 8826			AA1012508129			60.016		
					IS 2062 Gr. A			1		
	03	PL. 8x80x8700			AA1011808056			40.621		
					IS 2062 Gr. A			2		
	02	EA 75x75x6 ; 833			AA1012508129			5.664		
					IS 2062 Gr. A			9		
	01	PL. 5x900x8826			AA1011808013			311.778		
					IS 2062 Gr. A			1		

TYPE OF PRODUCT OR NAME OF CUSTOMER/PROJECT		BHARAT HEAVY ELECTRICALS LTD., UNIT: BOILER AUXILIARIES PLANT. RANIPET - 632 406.		DRN	K VENKAT	SIGN	DATE	NO.OF VAR.
DEPT		AGCS	GRADE OF UNTOL.DIM	SCALE	WEIGHT (KG).	REF. TO ASSY/OLD DRG.	ITEM NO.	NO. OF ITEMS
CODE		862	PR: QA:500	N.T.S	****	-	-	-
TITLE		TOP PANEL RIGHT (GD HOUSING)		CARD CODE	DRAWING NO.		REV	
				U 01	2-79-849-07610		00	

CAUTION: The information on this document is the property of BHARAT HEAVY ELECTRICALS LTD. It must not be used directly or indirectly in any way detrimental to the interest of the company.

REV	DATE	ALTERED	CHECKED

COPYRIGHT AND CONFIDENTIAL
THE INFORMATION ON THIS DOCUMENT IS THE PROPERTY OF BHARAT HEAVY ELECTRICALS LIMITED.
IT MUST NOT BE USED DIRECTLY OR INDIRECTLY IN ANY WAY DETRIMENTAL TO THE INTEREST OF THE COMPANY.

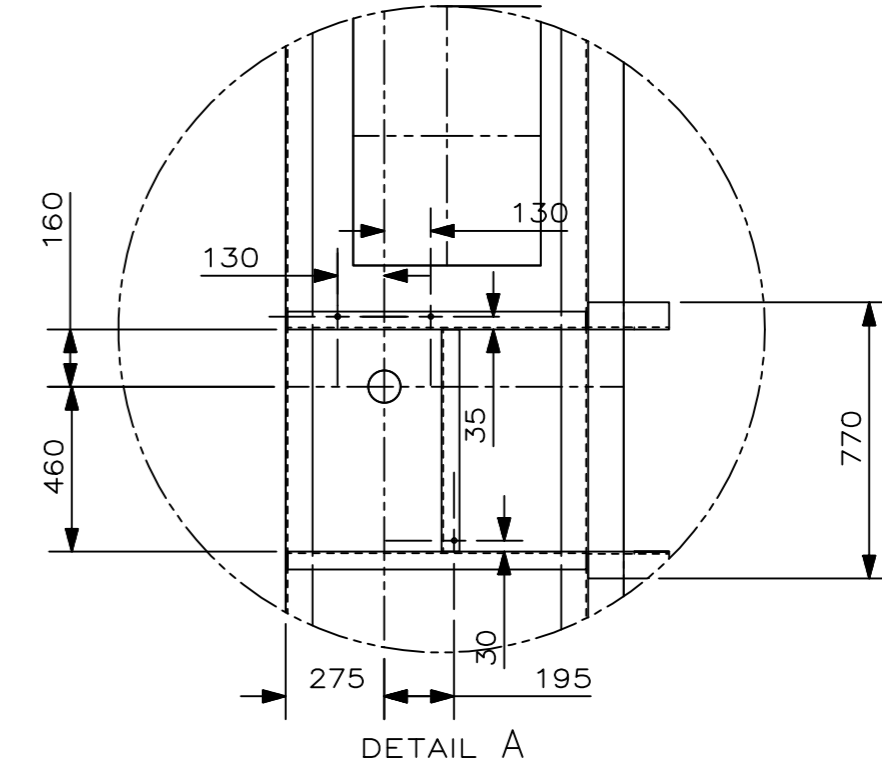
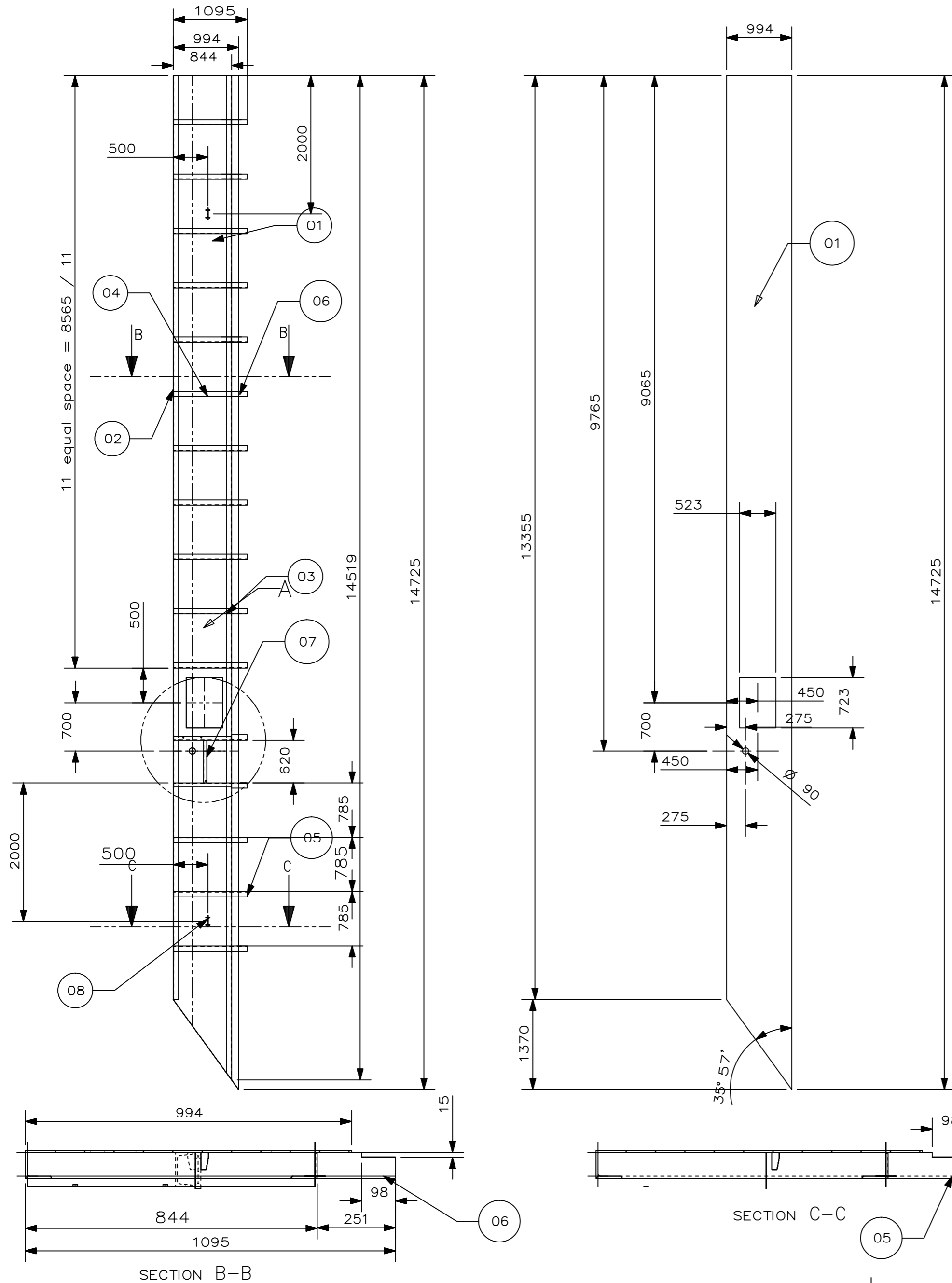

NOTES:
FOR FABRICATION REFER RELEVANT QWI.
TOLERANCE:
LENGTH : ±5 MM
DIAGONAL: ±7 MM
CAMBER: 1 MM/M MAX. 5 MM
SEWWP: 1MM/M MAX. 5MM
FOR UNTOLERENCEDDIMWENSON REFER RELEVANT QWI.
FOR PAINTING REFER RELEVANT QWI.
FOR FAB/OTHER WELDING DETAILS REFER
DRG.1-79-049-00550 & 00553

VAR NO	ITEM NO	DESCRIPTION	STD	DRAWING NO	ITEM NO	MATL. CODE	A	DI	UNIT	UNIT.WT	GS	ZONE
										QUANTITY		
	08	LIFTING EYE-D50				942230050000 61810130				1.510 2		
	07	MC 100-RM				AA1012708039 IS 2062 GR.A		MR		9.560 2.38		
	06	EA 75X75X6-251				AA1012508129 IS 2062 GR.A				1.634 12		
	05	EA 75X75X6-251				AA1012508129 IS 2062 GR.A				1.634 4		
	04	EA 75X75X6-832				AA1012508129 IS 2062 GR.A				5.657 14		
	03	EA 75X75X6-14519				AA1012508129 IS 2062 GR.A				98.729 1		
	02	EA 75X75X6-13355				AA1012508129 IS 2062 GR.A				90.814 1		
	01	PL 5X994X14725				AA1011808013 IS 2062 GR.A				532.512 1		

TYPE OF PRODUCT
OR
NAME OF CUSTOMER/ PROJECT

	BHARAT HEAVY ELECTRICALS LTD.		NAME	SIGN	DATE	NO.OF VAR.
	RANIPET		DRN	VENKAT K	09.10.18	
			CHD	TNR	9.10.18	
		APD	C.GANESH	09.10.18	73, 74	

REV.	DATE	ALTERED	CHECKED	DEPT. AQCS	SCALE	WEIGHT(Kg)	REF. TO ASSY. DRG.	ITEM NO.	NO.OF ITEMS
				862		****.***			75, 77
TITLE							1	3	REV
SIDE PANEL (GD - RAP RIGHT)									00
DRAWING NO.							2-79-849-07614		

ALL DIMENSIONS ARE IN MILLIMETERS

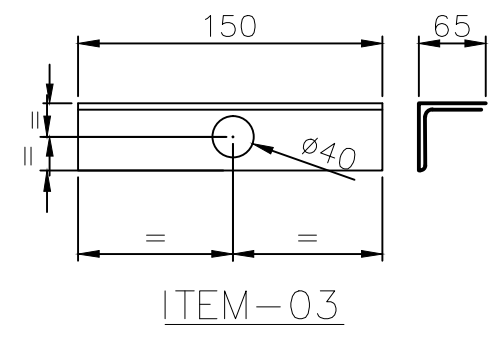
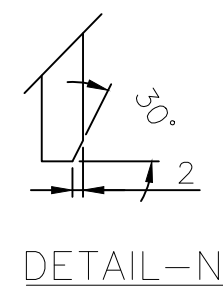
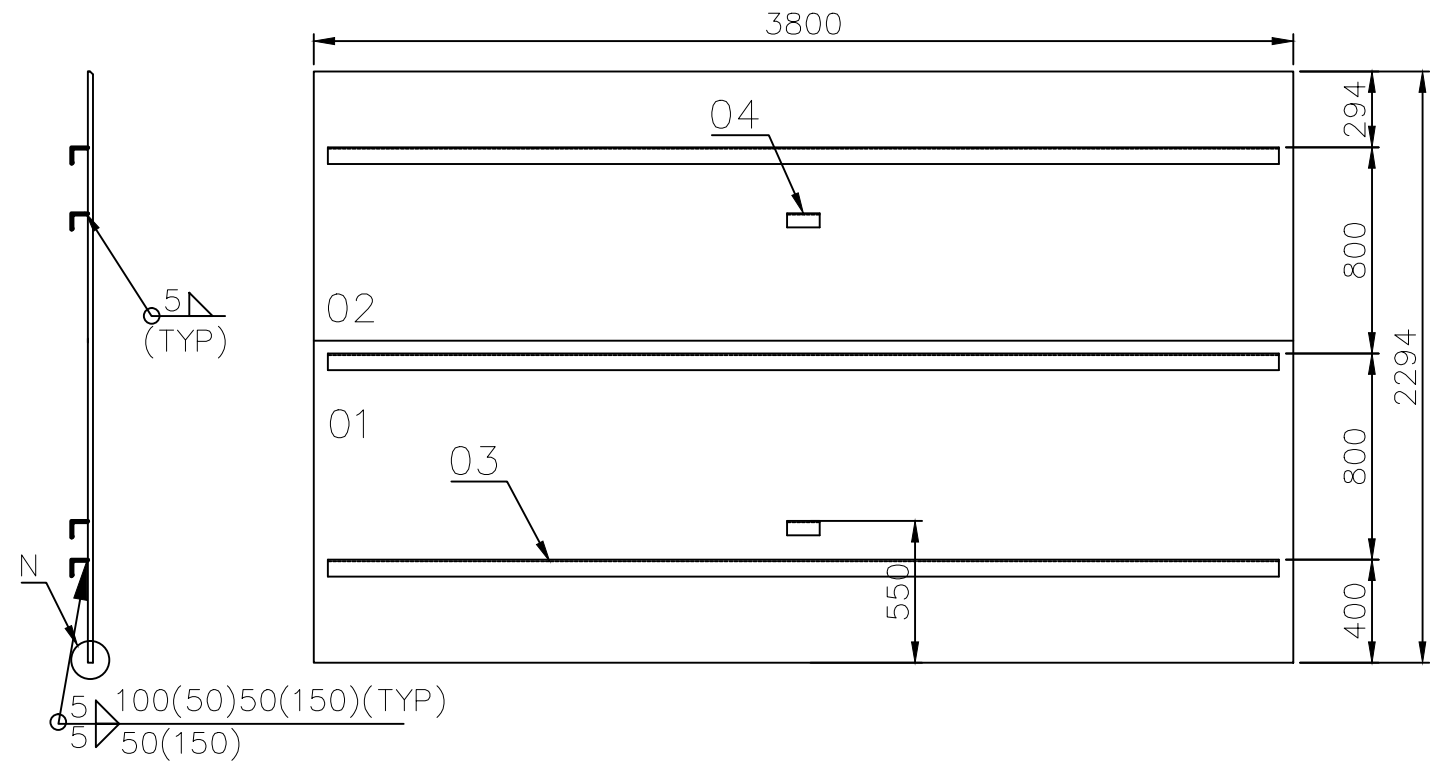

NUMBER	ITEM NUMBER	DESCRIPTION	STD	DRAWING NUMBER/SIZE	ITEM NO	MATERIAL CODE	A/C	UNIT	UNIT WEIGHT	GS	ZONE
					VAR NO	MATERIAL SPECN		D1	QUANTITY		
	03	ISA 65x65x6-150				AA1012608077			0.87		
						IS 2062 GR-A			2		
	01	UEA 125X75X8-3690				AA1012608077			44.649		
						IS 2062 GR-A			3		
	01	PLATE 8x3800x2294				150110372600			547.440		
						IS 2062 GR-A			1		

NOTES:

- 01. FOR FABRICATION REFER RELEVANT QWI
- 02. FOR UNTOL DIMENSION REFER PR:QA;500
- 03. FOR PAINTING REFER RELEVANT QWI

REV	DATE	ALTERED
00	-	CHECKED

TYPE OF PRODUCT OR NAME OF CUSTOMER/PROJECT											
05-227/D		Bharat Heavy Electricals Ltd				DRN	KCM	SIGNATURE	DATE	NO. OF VAR	
		BOILER AUXILIARIES PLANT RANIPET-632 406				CHD	C.G		12.05.18	-	
DEPT AQCS		GRADE OF UNTOL DIM PR:QA:500		SCALE - NTS		WEIGHT (Kg) 683.127		REF TO ASSY / OLD DWG -		ITEM NO -	
CODE 862										No OF ITEMS -	
TITLE						CARD CODE		DRAWING NO :		REV	
ROOF PANEL-2						U 01		3-79-447-0381800		00	

CAUTION: The information on this document is the property of BHARAT HEAVY ELECTRICALS LTD. It must not be used directly or indirectly in any way detrimental to the interest of the company.

ALL DIMENSIONS ARE IN MILLIMETERS

NOTES:

- 01. FOR FABRICATION REFER RELEVANT QWI
- 02. FOR UNTOL DIMENSION REFER PR:QA;500
- 03. FOR PAINTING REFER RELEVANT QWI

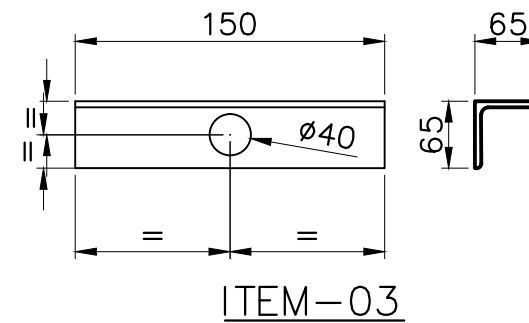
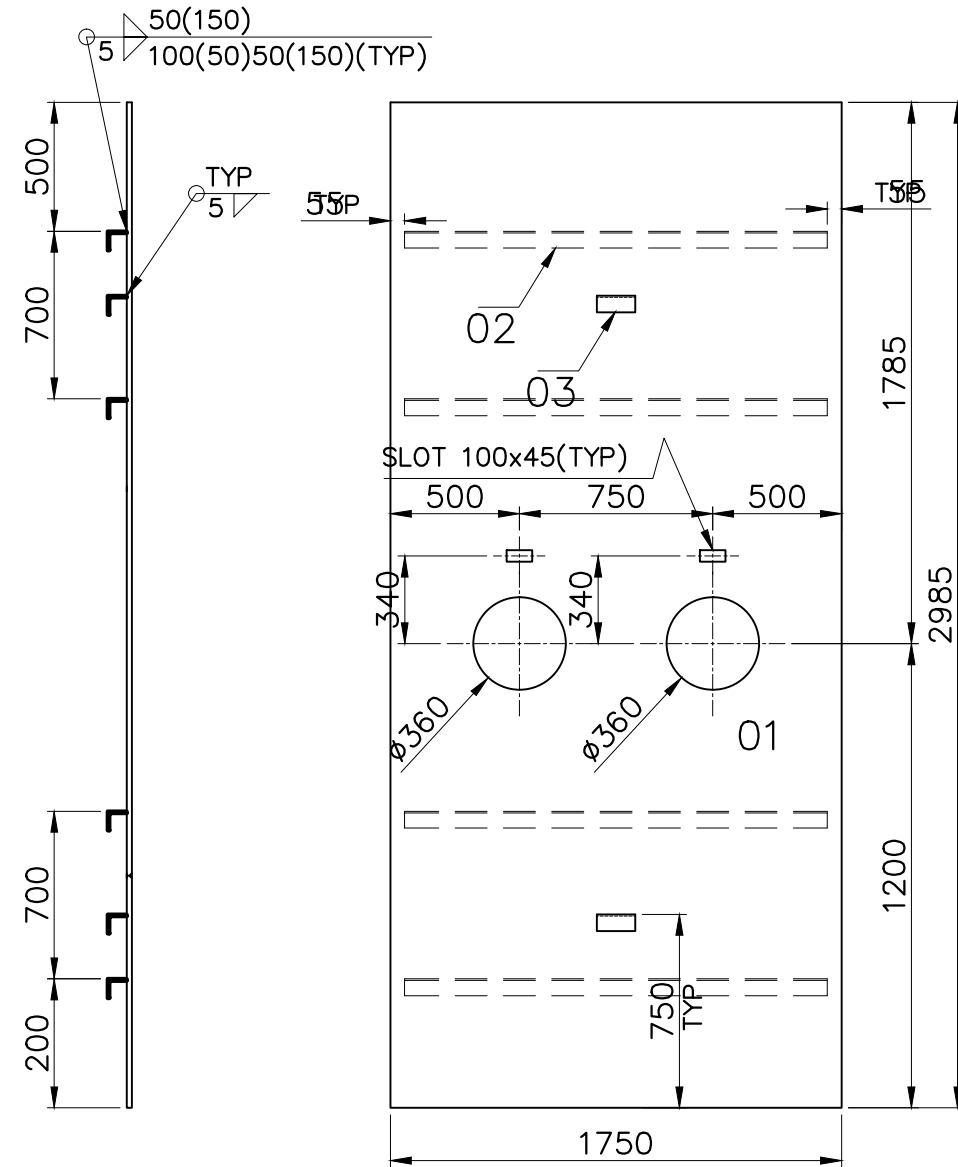

NUMBER	ITEM NUMBER	DESCRIPTION	STD	DRAWING NUMBER/SIZE	ITEM NO	MATERIAL CODE	A/C	UNIT	UNIT WEIGHT	GS	ZONE
					VAR NO	MATERIAL SPECN		D1	QUANTITY		
	03	ISA 65X65X6-150				AA1012508099			0.870		
						IS 2062 GR-A			2		
	02	ISA 65x65x6-1640				AA1012508099			9.512		
						IS 2062 GR-A			4		
	01	PLATE 6x1750x2985				AA1011808030			236.097		
						IS 2062 GR-A			1		

REV	DATE	ALTERED
		CHECKED

CAUTION: The information on this document is the property of BHARAT HEAVY ELECTRICALS LTD. It must not be used directly or indirectly in any way detrimental to the interest of the company.

TYPE OF PRODUCT OR NAME OF CUSTOMER/PROJECT		05-227/D		Bharat Heavy Electricals Ltd		DRN	KCM	NAME	SIGNATURE	DATE	NO. OF VAR
		BHEL		BOILER AUXILIARIES PLANT		CHD	BVR			08.09.2020	-
				RANIPET-632 406		APPD	TNR			08.09.2020	-
DEPT	AQCS	GRADE OF UNTOL. DIM	PR:QA:500	SCALE	-	WEIGHT (Kg)	275.885	REF TO ASSY / OLD DWG	-	ITEM NO	No OF ITEMS
CODE	862				NTS					-	-
TITLE		INSU.SUPT.PANEL-5		CARD CODE	U 01	DRAWING NO :		3-79-446-0395500		REV	

Section-VI

Enquiry No.652002E

Dt.02.03.2023

Flow chart for processing of Material Account Statement (MAS)

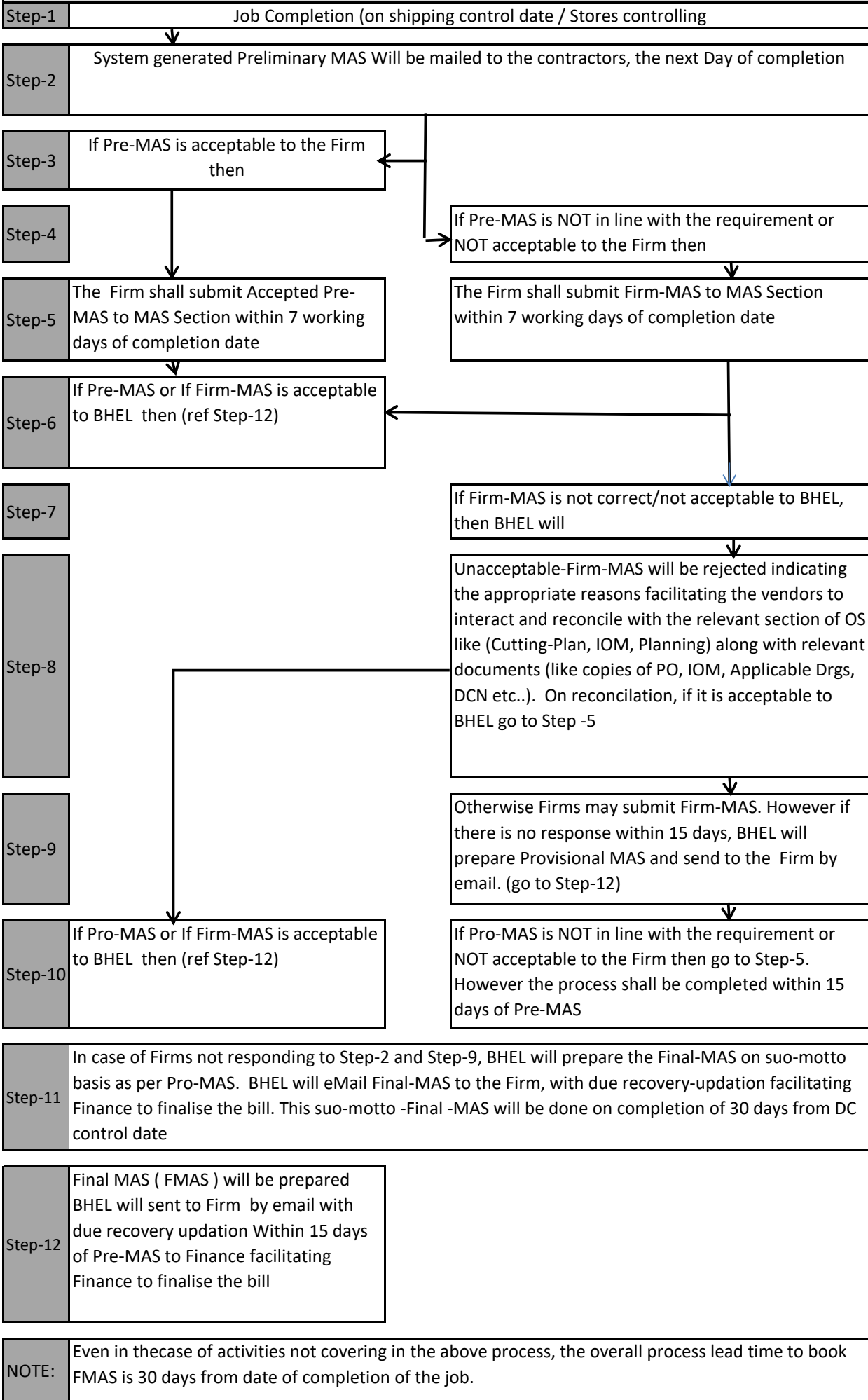

NOTE: Even in the case of activities not covering in the above process, the overall process lead time to book FMAS is 30 days from date of completion of the job.

SECTION-VIII

 An ISO Company	BHARAT HEAVY ELECTRICALS LIMITED (A Government of India Undertaking) பாரதமீக்ரமின் நிறுவனம்	Ph: 04172-284030, 284323, 241120 Email: bsmanian@bhel.in ssvasan@bhel.in
	BOILER AUXILIARIES PLANT, Indira Gandhi Industrial Complex,	
	RANIPET- 632 406 (Tamil Nadu)	

BHEL-BAP-OS-54A-ARC-2023-24

SECTION – VIII - List of Approved vendors for (A) Welding Consumable ,Paints, Penetrant Chemicals and (B) Conducting NDT, Galvanising,Blasting and Heat Treatment

Ref	Description	Page No
1	List of approved welding Consumables Suppliers	01 to 27
2	List of approved Paint Suppliers	01 to 03
3	List of approved Suppliers for Penetrant Chemicals	01 to 05
4	List of approved NDT vendors	01 to 05
5	List of approved Galvanizing Vendor	01 to 01
5	List of approved Blasting vendor	01 to 01
6	List of approved Heat Treatment Vendor	01 to 04

**SECTION - VIII
LIST OF APPROVED VENDORS**

1) WELDING CONSUMABLES SUPPLIERS LIST

Mat Group	Material Group Description	Vendor No	Vendor Name	Vendor Address	EMAIL	PHONE1
DRMFL	WELDING FLUX-DRUM	20047	KANEMATSU TRADING CORPORATION	6th FLOOR,AKEBONO NIHONBASHI BLDG,19 - 5,NIHONBASHIKOAMI-CHO,CHUO - KU, TOKYO, 103 - 0016.	nikko-bocki@kgt.kanematsu.co.jp	81 3 5283 3680
		10081	ESAB INDIA LTD	KARUMUTTU CENTRE, 6TH FLOORNEW NO.634(OLD NO.498)ANNA SALAI, NANDANAM,CHENNAI-35CHENNAI	jagdeesh.ds@esab.co.in	044-826 9343
		11712	TAPADIA ENGINEERS & TRADERS P.LTD.	2, INDUSTRIAL ESTATE,BHANPURI, CHATTISGARH.RAIPUR	tet_tgirpr@rediffmail.com	0770 - 4090636
FINFL	WELDING FLUX-FIN	11712	TAPADIA ENGINEERS & TRADERS P.LTD.	2, INDUSTRIAL ESTATE,BHANPURI, CHATTISGARH.RAIPUR	tet_tgirpr@rediffmail.com	0770 - 4090636
		19371	NDT FLUXES.	SURAJ,35,VIVEKANANDA NAGAR,RAIPUR		
GVW01	WELDING ELECTRODES	11378	MAILAM INDIA LIMITED	MAILAM MAIN ROAD,SEDARAPET,PONDICHERRY	mailam@mailanindia.com	0413-2677311
		80019	ESAB INDIA LTD.	KIRTI NAGAR		
		80018	D & H INDIA LIMITED	182/75, INDUSTRIAL AREA PH- 1CHANDIGARH	dnhindiachd@yao.co.in	0172- 2653063
		80020	HONAVAR ELECTRODES PVT LTD	Industrial Complex, 9, LBS Marg, Kurla (West)Mumbai	honavarelectrodes@gmail.com	9820249301
		10774	D&H SECHERON ELECTRODES PVT LTD.	P.B.NO.344-46,INDL.ESTATE,KILAMAIDANINDORE	sales@dnhsecheron.net	0731-4229222
		80291	Bharat Heavy Electricals Limited ,T	TiruvaramburTrichy		
		80218	M/s Modi Arc Electrodes Co.	G.T. Road, Oil Mill Gate, Modinagar		
		80126	Ador Welding Limited	C-116, Naraina Industrial Area, Phase-1New Delhi	delhi@adorwelding.com	1141411049
10936	AHURA WELDING ELECTRODE MANUFACTURE	SF 139 & 144/3 THIRUMALAYAMPALAYAMPALGHAT ROADPALGHAT ROADCOIMBATORE	sunarc@md2.vsnl.net.in	0422 - 822232		
GVW02	WELDING WIRE	80291	Bharat Heavy Electricals Limited ,T	TiruvaramburTrichy		
GVW03	WELDING ELECTRODE OT	80291	Bharat Heavy Electricals Limited ,T	TiruvaramburTrichy		
GVW04	COBALT POWDER	80291	Bharat Heavy Electricals Limited ,T	TiruvaramburTrichy		
GVWFX	WELDING FLUX	10785	ADOR WELDING LIMITED	CORPORATE MARKETING OFFICE,P.B. NO. 2, CHINCHWAD,PUNE	acegasindia@gamail.com	
		10015	ANITA FLUXES ALLOY SPECIALITY	24, 3RD PHASEPEENYA INDUSTRIAL ESTATEBANGALOREBANGALORE		080/ 839 4411
MIGA1	GMAW WIRE ER80S-B3L	20563	BOHLER SCHWEISSTECHNNIK	UNIONSTRASSE-1,D-59067 HAMM,DEUTSCHLAND GmbH.,GERMANY		
		20047	KANEMATSU TRADING CORPORATION	6th FLOOR,AKEBONO NIHONBASHI BLDG,19 - 5,NIHONBASHIKOAMI-CHO,CHUO - KU, TOKYO, 103 - 0016.	nikko-bocki@kgt.kanematsu.co.jp	81 3 5283 3680

**SECTION - VIII
LIST OF APPROVED VENDORS**

1) WELDING CONSUMABLES SUPPLIERS LIST

Mat Group	Material Group Description	Vendor No	Vendor Name	Vendor Address	EMAIL	PHONE1
		21411	METRODE PRODUCTS LIMITED,	HANWORTH LANE,CHERTESSY,SURREY KT169LL,		
		22391	AIR-LIQUIDE WELDING FRANCE,	13,RUE D'EPLUCHES-BP70024 SAINT-OUEN I'AUMONE,95315 CERGY PONTOISE CEDEX	jean-paul.shmitt@airliquide.com	1342 13480
MIGA2	GTAW WIRE FOR T92	20563	BOHLER SCHWEISSTECHNNIK	UNIONSTRASSE-1,D-59067 HAMM,DEUTSCHLAND GmbH.,GERMANY		
		21411	METRODE PRODUCTS LIMITED,	HANWORTH LANE,CHERTESSY,SURREY KT169LL,		
MIGA4	ER80S-B2 BPGMAW WIRE	21411	METRODE PRODUCTS LIMITED,	HANWORTH LANE,CHERTESSY,SURREY KT169LL,		
		10081	ESAB INDIA LTD	KARUMUTTU CENTRE, 6TH FLOORNEW NO.634(OLD NO.498)ANNA SALAI, NANDANAM,CHENNAI-35CHENNAI	jagdeesh.ds@esab.co.in	044-826 9343
MIGN1	GMAWWIRE ERNiCRFe-7A	21991	SPECIAL METALS WELDING PRODUCTS	1401,BURRIS ROAD,NEWTON,NORTH COROLINA 28658	rphillips@smwpc.com	828-465-0352
		20047	KANEMATSU TRADING CORPORATION	6th FLOOR,AKEBONO NIHONBASHI BLDG,19 - 5,NIHONBASHIKOAMI-CHO,CHUO - KU, TOKYO, 103 - 0016.	nikko-bocki@kgt.kanematsu.co.jp	81 3 5283 3680
MIGS1	GMW WIRE ER308H	20130	ALCONIX CORPORATION	SANNO PARK TOWER,12TH FLOOR,2-11-1 NAGATA-CHO,CHIYODA-KU,TOKYO ,JAPAN	Inamori.khei@alconix.com	
		20067	UTP SCHWEISS MATERIAL GMBH & CO	ELSASSER STR 10D-79189, BAD KROZINGENGERMANY.		49(0) 07633 / 40
		20047	KANEMATSU TRADING CORPORATION	6th FLOOR,AKEBONO NIHONBASHI BLDG,19 - 5,NIHONBASHIKOAMI-CHO,CHUO - KU, TOKYO, 103 - 0016.	nikko-bocki@kgt.kanematsu.co.jp	81 3 5283 3680
MIGS2	GMAW WIRE ER309LSi	20130	ALCONIX CORPORATION	SANNO PARK TOWER,12TH FLOOR,2-11-1 NAGATA-CHO,CHIYODA-KU,TOKYO ,JAPAN	Inamori.khei@alconix.com	
		20047	KANEMATSU TRADING CORPORATION	6th FLOOR,AKEBONO NIHONBASHI BLDG,19 - 5,NIHONBASHIKOAMI-CHO,CHUO - KU, TOKYO, 103 - 0016.	nikko-bocki@kgt.kanematsu.co.jp	81 3 5283 3680
		20067	UTP SCHWEISS MATERIAL GMBH & CO	ELSASSER STR 10D-79189, BAD KROZINGENGERMANY.		49(0) 07633 / 40
		22391	AIR-LIQUIDE WELDING FRANCE,	13,RUE D'EPLUCHES-BP70024 SAINT-OUEN I'AUMONE,95315 CERGY PONTOISE CEDEX	jean-paul.shmitt@airliquide.com	1342 13480
		22391	AIR-LIQUIDE WELDING FRANCE,	13,RUE D'EPLUCHES-BP70024 SAINT-OUEN I'AUMONE,95315 CERGY PONTOISE CEDEX	jean-paul.shmitt@airliquide.com	1342 13480
		20130	ALCONIX CORPORATION	SANNO PARK TOWER,12TH FLOOR,2-11-1 NAGATA-CHO,CHIYODA-KU,TOKYO ,JAPAN	Inamori.khei@alconix.com	

**SECTION - VIII
LIST OF APPROVED VENDORS**

1) WELDING CONSUMABLES SUPPLIERS LIST

Mat Group	Material Group Description	Vendor No	Vendor Name	Vendor Address	EMAIL	PHONE1
MIGS3	GMAW WIRE ER309L	20047	KANEMATSU TRADING CORPORATION	6th FLOOR,AKEBONO NIHONBASHI BLDG,19 - 5,NIHONBASHIKOAMI-CHO,CHUO - KU, TOKYO, 103 - 0016.	nikko-bocki@kgt.kanematsu.co.jp	81 3 5283 3680
		20067	UTP SCHWEISS MATERIAL GMBH & CO	ELSASSER STR 10D-79189, BAD KROZINGENGERMANY.		49(0) 07633 / 40
MIGW1	ER 70S-A1 GMAW WIRE	20047	KANEMATSU TRADING CORPORATION	6th FLOOR,AKEBONO NIHONBASHI BLDG,19 - 5,NIHONBASHIKOAMI-CHO,CHUO - KU, TOKYO, 103 - 0016.	nikko-bocki@kgt.kanematsu.co.jp	81 3 5283 3680
		20011	BOHLER SCHWEISSTECHNIK AUSTRIA	WERK DEUCHENDORF,A 8605, KAPPENBERG, POSTFACH - 9,AUSTRIA.AUSTRIA.		0043/3862301
		21411	METRODE PRODUCTS LIMITED,	HANWORTH LANE,CHERTESSY,SURREY KT169LL,		
		20563	BOHLER SCHWEISSTECHNNIK	UNIONSTRASSE-1,D-59067 HAMM,DEUTSCHLAND GmbH.,GERMANY		
MIGW2	ER 80S-B2 GMAW WIRE	20047	KANEMATSU TRADING CORPORATION	6th FLOOR,AKEBONO NIHONBASHI BLDG,19 - 5,NIHONBASHIKOAMI-CHO,CHUO - KU, TOKYO, 103 - 0016.	nikko-bocki@kgt.kanematsu.co.jp	81 3 5283 3680
		21411	METRODE PRODUCTS LIMITED,	HANWORTH LANE,CHERTESSY,SURREY KT169LL,		
		10774	D&H SECHERON ELECTRODES PVT LTD.	P.B.NO.344-46,INDL.ESTATE,KILAMAIDANINDORE	sales@dhsecheron.net	0731-4229222
MIGW3	ER 90S-B3 GMAW WIRE	20047	KANEMATSU TRADING CORPORATION	6th FLOOR,AKEBONO NIHONBASHI BLDG,19 - 5,NIHONBASHIKOAMI-CHO,CHUO - KU, TOKYO, 103 - 0016.	nikko-bocki@kgt.kanematsu.co.jp	81 3 5283 3680
		20563	BOHLER SCHWEISSTECHNNIK	UNIONSTRASSE-1,D-59067 HAMM,DEUTSCHLAND GmbH.,GERMANY		
		21461	INDUSTRIA NAZIONALE ELETTRODI S.p.A	Via.FACCA 10,CITTADELLA, 35013ITALY.		
		21411	METRODE PRODUCTS LIMITED,	HANWORTH LANE,CHERTESSY,SURREY KT169LL,		
MIGW4	WELDG.WIRE-MIG ER347	22391	AIR-LIQUIDE WELDING FRANCE,	13,RUE D'EPLUCHES-BP70024 SAINT-OUEN l'AUMONE,95315 CERGY PONTOISE CEDEX	jean-paul.shmitt@airliquide.com	1342 13480
		11784	VENUS WIRE INDUSTRIES PVT LTD	19, RAGHUVANSHI MILL COMPOUNDS.B.MARG, LOWER PARELMUMBAI	sales@venuswires.com	022 - 4978840
		21411	METRODE PRODUCTS LIMITED,	HANWORTH LANE,CHERTESSY,SURREY KT169LL,		
		20047	KANEMATSU TRADING CORPORATION	6th FLOOR,AKEBONO NIHONBASHI BLDG,19 - 5,NIHONBASHIKOAMI-CHO,CHUO - KU, TOKYO, 103 - 0016.	nikko-bocki@kgt.kanematsu.co.jp	81 3 5283 3680

**SECTION - VIII
LIST OF APPROVED VENDORS**

1) WELDING CONSUMABLES SUPPLIERS LIST

Mat Group	Material Group Description	Vendor No	Vendor Name	Vendor Address	EMAIL	PHONE1
MIGW5	WELDG.WIRE-MIG ERNIC	22391	AIR-LIQUIDE WELDING FRANCE,	13,RUE D'EPLUCHES-BP70024 SAINT-OUEN I'AUMONE,95315 CERGY PONTOISE CEDEX	jean-paul.shmitt@airliquide.com	1342 13480
		21411	METRODE PRODUCTS LIMITED,	HANWORTH LANE,CHERTESSY,SURREY KT169LL,		
		20047	KANEMATSU TRADING CORPORATION	6th FLOOR,AKEBONO NIHONBASHI BLDG,19 - 5,NIHONBASHIKOAMI-CHO,CHUO - KU, TOKYO, 103 - 0016.	nikko-bocki@kgt.kanematsu.co.jp	81 3 5283 3680
		20067	UTP SCHWEISS MATERIAL GMBH & CO	ELSASSER STR 10D-79189, BAD KROZINGENGERMANY.		49(0) 07633 / 40
MIGW6	WELDG.WIRE-MIG ER90S	20563	BOHLER SCHWEISSTECHNNIK	UNIONSTRASSE-1,D-59067 HAMM,DEUTSCHLAND GmbH.,GERMANY		
		22391	AIR-LIQUIDE WELDING FRANCE,	13,RUE D'EPLUCHES-BP70024 SAINT-OUEN I'AUMONE,95315 CERGY PONTOISE CEDEX	jean-paul.shmitt@airliquide.com	1342 13480
		21411	METRODE PRODUCTS LIMITED,	HANWORTH LANE,CHERTESSY,SURREY KT169LL,		
		20011	BOHLER SCHWEISSTECHNIK AUSTRIA	WERK DEUCHENDORF,A 8605, KAPPENBERG, POSTFACH - 9,AUSTRIA.AUSTRIA.		0043/3862301
		91270	VEEPEES INDIA,	C-52, 4TH AVENUE ROAD,GUINDY INDUSTRIAL ESTATE,GUINDY.CHENNAI	veepeesindia@gmail.com	044-43534354
		14428	SHAKUNT ENTERPRISES PRIVATE LIMITED	G.T.ROADSANWALKA BHAWANMILLER GANJLUDHIANA	shakunt@satyam.net.in	161 2538323
		18705	MODI HITECH INDIA LTD.,	1400,MODI TOWER98,NEHRU PLACE,NEW DELHI	gmmelectrode@gmail.com	011 4250 4577
		16661	KLINWELD WIRES PVT. LTD.,	207,TIMMY ARCADE,MAKWANA NAKA, ANDHERI (EAST)MUMBAI	wires@vsnl.net	022 28504848
		17841	PRASHANTH CYLINDERS PVT. LTD.,	35-B,VEERASANDRA INDL. ESTATE,19th K.M.HOSUR ROAD,ELECTRONIC CITY POST,BANGALORE		
		17842	PRECISION DRAWEL PVT., LTD.,	KHASARA NO.221&222/2,VILLAGE TEKADI,TAH. PARSEONI,NAGPUR		
		16548	WELD EXCEL INDIA LTD.,	D-230,PHASE VII,FOCAL POINT,LUDHIANA		
		11288	JAGSHAAN INDUSTRIES	94 FRIENDS COLONYKATOL ROADNAGPUR	jagshaan@nagpur.dot.net.in	0712 - 581557
		10758	ALPHA ARC INDUSTRIES,	B-5,SECTOR A5/6 TRONICA CITYLONIGHAZIABAD, UP	alphaarc@yahoo.com	0 99114 41441
		16662	NATIONAL ENGINEERING ENTERPRISES,	C-9,1st PHASE,INDUSTRIAL AREA,ADITYAPUR,JAMSHEDPUR	nationaljsr@redifmail.com	0657 6539875
		10774	D&H SECHERON ELECTRODES PVT LTD.	P.B.NO.344-46,INDL.ESTATE,KILAMAIDANINDORE	sales@dhsecheron.net	0731-4229222
		13763	CLASSIC ELECTRODES (INDIA) LTD.,	1, BONFIELD LANE2 ND FLOORKOLKATA	classicelectrodes@yahoo.co.in	033 22429581

**SECTION - VIII
LIST OF APPROVED VENDORS**

1) WELDING CONSUMABLES SUPPLIERS LIST

Mat Group	Material Group Description	Vendor No	Vendor Name	Vendor Address	EMAIL	PHONE1
MIGW7	GMAW WIRE ER70S-6	13743	UNIQUE WELDING PRODUCTS PVT.LTD.,	PLOT NO.1205,G.I.D.C. PHASE-IVVITTHAL UDYOGNAGAR,ANAND-388121GUJARAT	ump_vvn@rediffmail.com	02692-236 092...
		11528	RAAJRATNA ELECTRODES LTD	11, SONAROOA, OPP.LALBANGLOWC.G.ROAD, NAVARANGPURA AHMEDABAD	mktg@gnahd-rel.global.net.in	079 - 6445258
		14575	WELD ALLOY PRODUCTS,	C - 33, SECTOR - IV, NOIDANOIDA DIST.GAUTAM BUDH NAGAR (UP)	wap2005@airtelmail.in	0120-2557183
		17644	VARUN ELECTRODES PVT. LTD.,	H-56,INDUSTRIAL AREA,PANIPAT	kapoor@varunelectrodes.com	0180 2653085
		10737	SRI DHARAANI STEEL,	1060/463,SIVAKASI- VIRUDHUNAGARROAD,THIRUTHANGAL- 626130VIRUDHUNAGAR DIST.	wire@sridharaanisteel.com	98943-88857
		16575	STANDARD WIRE PRODUCTS	219, SIDCO INDUSTRIAL ESTATE,AMBATTUR,CHENNAI		044 26254946
		17813	K.M.CROWN WELDING CONSUMABLES PVT.,	BLOCK NO.16A,16B & 17A,INDUSTRIAL AREA NO.1,A.B.ROAD,DEWAS	kmcrownwelding@dataone.com	07272 259384578
		13911	ROYAL ARC ELECTRODES PVT. LTD	ROYAL HOUSE, PLOT NO.26,VILLAGE VALIV,VASAI (EAST)THANE	royalarc@vsnl.com	0250 2480520
		13693	RASI ELECTRODES LTD.,	21, RAJA ANNAMALAI ROAD,FLAT NO A / 14, THIRD FLOOR,CHENNAI	rele@airtelmail.in	044 26424523
		17814	CALCUTTA ELECTRODES PVT. LTD.,	SARDAR PATEL TIMBER MARKET,BHANPURI,RAIPUR	calcutta_electrodes2006@yahoo.com	0771 4090615
		13986	B&H ELECTRODES PVT. LTD,	VILLAGE SAIDPURA, BARWALA ROAD,DERABASSI,MOHALI		
		15085	VOLTARC ELECTRODES (P) LTD,	10-77, FIRST MAIN,ROYAL NAGAR,H.O.SURYAJYOTHI,R.C.ROAD, P.B.NO.33,TIRUPATHI	voltarc@rediffmail.com	0877 2241462
		14455	WIRE AND WIRE PRODUCTS	SIDCO INDUSTRIAL ESTATEAMBATTURCHENNAI	www@vsnl.net	044 26242378
		15810	NOUVEAUX INDUSTRIES (P) LTD.,	NO.2,SOWDAMBIGA NAGARTIRUPUR ROAD.KANGAYAM		
		14340	NALLI ARC INDUSTRIE,	SF NO. 340,NALLIPALAYAM,PADIYUR POST,KANGAYAM TALUKERODE Dt.	nalliar@yaho.com	04257 245185
		13906	MARUTI WELD LIMITED,	I-1, KIRTI NAGARNEW DELHI	marutiweld@marutiweld.com	25913411
		15101	PRECISION WELDARC LTD,	49,B.T. ROAD, PANIHATI24,PARGANAS (NORTH) KOLKATA.	pwires@yahoo.co.in	033 25634753
		15100	MANTEK WIRES	24,SIDCO INDUSTRIAL ESTATE,P.VADUGAPALAYAM,PALLADAMCOIMBAT ORE		

**SECTION - VIII
LIST OF APPROVED VENDORS**

1) WELDING CONSUMABLES SUPPLIERS LIST

Mat Group	Material Group Description	Vendor No	Vendor Name	Vendor Address	EMAIL	PHONE1
		16166	EVERSHINE WIRES	178/2-A3, THURAIYUR ROAD,PULIVALAM,MUSIRI TALUK,TRICHY	evershinewires@rediffmail.com	04327 235527
		13549	ATHARVE WELDING TECHNOLOGIES (INDIA	PVT.LTD.,A 192,M.I.D.C.CHINCHOLI,SOLAPUR	atharv.wt@hotmail.com	0217-273 7029
		10081	ESAB INDIA LTD	KARUMUTTU CENTRE, 6TH FLOORNEW NO.634(OLD NO.498)ANNA SALAI, NANDANAM,CHENNAI-35CHENNAI	jagdeesh.ds@esab.co.in	044-826 9343
		11378	MAILAM INDIA LIMITED	MAILAM MAIN ROAD,SEDARAPET,PONDICHERRY	mailam@mailanindia.com	0413-2677311
		14791	ANAND ARC LTD.,	NO.22(OLD.31),RAILWAY COLONY,III STREET ,AMINJIKARAI,CHENNAI		044 23746379
		10785	ADOR WELDING LIMITED	CORPORATE MARKETING OFFICE,P.B. NO. 2, CHINCHWAD,PUNE	acegasindia@gamail.com	
		13487	MAGNARC ELECTRODES PVT.LTD.,	PENDUTHIVISAGAPATNAM	magnarc@hotmail.com	0891-276 4381...
		13211	D&H INDIA LIMITED	PLOT 'A', SECTOR 'A'INDUSTRIAL AREA,SANWER ROADINDORE	dhindia@sancharnet.in	0731-4273501-...
		14458	M W WIRETECK PVT. LTD.	GF-9, GURU ARJUN DEV BHAWAN,RANJIT NAGAR COM. CMPLX,NEW DELHI.	wire@wireteck.in	011 4540 7712
		13690	GEE LIMITED,	PLOT E-1, ROAD NO. 7,WAGLE INDUSTRIAL ESTATETHANE		
MIGW8	GMAW WIRE ER80S-G	21411	METRODE PRODUCTS LIMITED,	HANWORTH LANE,CHERTESSY,SURREY KT169LL,		
		20047	KANEMATSU TRADING CORPORATION	6th FLOOR,AKEBONO NIHONBASHI BLDG,19 - 5,NIHONBASHIKOAMI-CHO,CHUO - KU, TOKYO, 103 - 0016.	nikko-bocki@kgt.kanematsu.co.jp	81 3 5283 3680
MIGW9	GMAW WIRE ER90S-G	21411	METRODE PRODUCTS LIMITED,	HANWORTH LANE,CHERTESSY,SURREY KT169LL,		
		20563	BOHLER SCHWEISSTECHNNIK	UNIONSTRASSE-1,D-59067 HAMM,DEUTSCHLAND GmbH.,GERMANY		
		20047	KANEMATSU TRADING CORPORATION	6th FLOOR,AKEBONO NIHONBASHI BLDG,19 - 5,NIHONBASHIKOAMI-CHO,CHUO - KU, TOKYO, 103 - 0016.	nikko-bocki@kgt.kanematsu.co.jp	81 3 5283 3680
MIGWA	GMWA WIRE FOR T23.	20130	ALCONIX CORPORATION	SANNO PARK TOWER,12TH FLOOR,2-11-1 NAGATA-CHO,CHIYODA-KU,TOKYO ,JAPAN	Inamori.khei@alconix.com	
		20047	KANEMATSU TRADING CORPORATION	6th FLOOR,AKEBONO NIHONBASHI BLDG,19 - 5,NIHONBASHIKOAMI-CHO,CHUO - KU, TOKYO, 103 - 0016.	nikko-bocki@kgt.kanematsu.co.jp	81 3 5283 3680
		21411	METRODE PRODUCTS LIMITED,	HANWORTH LANE,CHERTESSY,SURREY KT169LL,		

**SECTION - VIII
LIST OF APPROVED VENDORS**

1) WELDING CONSUMABLES SUPPLIERS LIST

Mat Group	Material Group Description	Vendor No	Vendor Name	Vendor Address	EMAIL	PHONE1
P91FL	WELDING FLUX-P91	22391	AIR-LIQUIDE WELDING FRANCE,	13,RUE D'EPLUCHES-BP70024 SAINT-OUEN I'AUMONE,95315 CERGY PONTOISE CEDEX	jean-paul.shmitt@airliquide.com	1342 13480
		20047	KANEMATSU TRADING CORPORATION	6th FLOOR,AKEBONO NIHONBASHI BLDG,19 - 5,NIHONBASHIKOAMI-CHO,CHUO - KU, TOKYO, 103 - 0016.	nikko-bocki@kgt.kanematsu.co.jp	81 3 5283 3680
		10081	ESAB INDIA LTD	KARUMUTTU CENTRE, 6TH FLOORNEW NO.634(OLD NO.498)ANNA SALAI, NANDANAM,CHENNAI-35CHENNAI	jagdeesh.ds@esab.co.in	044-826 9343
		20563	BOHLER SCHWEISSTECHNIK	UNIONSTRASSE-1,D-59067 HAMM,DEUTSCHLAND GmbH.,GERMANY		
		20011	BOHLER SCHWEISSTECHNIK AUSTRIA	WERK DEUCHENDORF,A 8605, KAPPENBERG, POSTFACH - 9,AUSTRIA.AUSTRIA.		0043/3862301
P92FL	SAWFLUX FOR SA335P92	20563	BOHLER SCHWEISSTECHNIK	UNIONSTRASSE-1,D-59067 HAMM,DEUTSCHLAND GmbH.,GERMANY		
SAWA1	SAWWIRE FOR SA335P92	21411	METRODE PRODUCTS LIMITED,	HANWORTH LANE,CHERTESY,SURREY KT169LL,		
		20563	BOHLER SCHWEISSTECHNIK	UNIONSTRASSE-1,D-59067 HAMM,DEUTSCHLAND GmbH.,GERMANY		
SSOFL	WELD:SS-OVERLAY FLUX	10785	ADOR WELDING LIMITED	CORPORATE MARKETING OFFICE,P.B. NO. 2, CHINCHWAD,PUNE	acegasindia@gamail.com	
		10015	ANITA FLUXES ALLOY SPECIALITY	24, 3RD PHASEPEENYA INDUSTRIAL ESTATEBANGALOREBANGALORE		080/ 839 4411
		13833	SUN FLUX,	PUTHUKUDI ROAD,RAYAMUNDANPATTITANJORE		
		15082	ROYAL WELDING WIRES PVT. LTD.,	7,KARANAI PUDUCHERRY VILLAGE,VIA.URAPAKKAM,KANCHIPURAM DIST,	royal@royalwires.co.in	044-3741 1610
		12184	LAKSHMI CHEMICAL INDUSTRIES	D-52, DEVELOPED PLOT ESTATETHUVAKUDITIRUCHIRAPALLI	lakshmi.chem@yahoo.com	9842550538
		13534	RUPA INDUSTRIES,	2-2-105 to 180/10,GANESH CHAMBERSRANIGUNJ,SECUNDERABAD	rupaent@vsnl.net	040-2771 3714
		13484	OSCAR AUTO FLUX,	3/216,INAMKULATHUR ROAD,AMMAPETTAI,POOLANGULATHUPATTY(PO), TRICHY	oscarautoflux@gmail.com	0431-2914567
		13691	MANTEK WELDAIDFLUX CO.	32, FIRST STREETGANDHI NAGARTHIRUVERUMBURTIRUCHIRAPPALLI	mantek@eth.net	2501540
		14593	R.M.H.CHEMICAL INDUSTRIES	C-12-A,DEVELOPED PLOTS ESTATE,THUVAKUDY,TIRUCHIRAPALLY	rmhfbbricators@vsnl.net	2500498

**SECTION - VIII
LIST OF APPROVED VENDORS**

1) WELDING CONSUMABLES SUPPLIERS LIST

Mat Group	Material Group Description	Vendor No	Vendor Name	Vendor Address	EMAIL	PHONE1
STRFL	SAW FLUX STRUCT.WELD	14309	S.CHEMS & ALLIED PRODUCERS PVT LIMI	PLOT NO.197,JANKIDEVI SCHOOL ROAD,MHADA BUNGALOW CSHEME,Nr. VARSOVA TEL. EXCHANGE,ANDHERI (W)MUMBAI	s chems@yahoo.co.in	022 26368557
		11701	SUPER WELD PRODUCTS	91/1 THINNANUR ROADPULIVALAM,MUSIRI TKTIRUCHIRAPALLI		0431 - 765626
		19114	WELMET TECHNOLOGIES PVT. LTD.,	34,P.N.MAIDU INDUSTRIAL ESTATE,M.I.D.C. HINGNA,NAGPUR		
		10785	ADOR WELDING LIMITED	CORPORATE MARKETING OFFICE,P.B. NO. 2, CHINCHWAD,PUNE	acegasindia@gamail.com	
		15099	THERMIT ALLOYS (P) LTD,	PLOT NO.7, INDUSTRIAL ESTATE,B.H.ROAD,SHIMOGA	thermit@vsnl.net	08182 250431
		17381	NOUVEOFLUX CHEMICAL COMPANY	1 /B 83 & 85, TIRUPUR ROADKANGAYAM		
		13211	D&H INDIA LIMITED	PLOT 'A', SECTOR 'A'INDUSTRIAL AREA,SANWER ROADINDORE	dhindia@sancharnet.in	0731-4273501-...
		11712	TAPADIA ENGINEERS & TRADERS P.LTD.	2, INDUSTRIAL ESTATE,BHANPURI, CHATTISGARH.RAIPUR	tet_tgirpr@rediffmail.com	0770 - 4090636
		13486	A V WELDTECH PVT.LTD.,	NO.206/12,CIVIL LINES,NEAR G.P.O. SQUARENAGPUR.	products@aveasyweld.com	0712-252 1727
		11288	JAGSHAAN INDUSTRIES	94 FRIENDS COLONYKATOL ROADNAGPUR	jagshaan@nagpur.dot.net.in	0712 - 581557
		15084	DWEKAM ELECTRODES LTD,	TALAWALI CHANDA,A.B.ROAD, P.O.MANGILAINDORE (MP)	vk.khandelwal@dwkam.org	0731 422 9500...
		15085	VOLTARC ELECTRODES (P) LTD,	10-77, FIRST MAIN,ROYAL NAGAR,H.O.SURYAJYOTHI,R.C.ROAD, P.B.NO.33,TIRUPATHI	voltarc@rediffmail.com	0877 2241462
		19695	SUBMER FLUX TECHNOLOGIES,	178/2A1,THURAIYUR ROAD,PULIVALAM,TRICHY		
		10466	SUN AUTO WELD INDUSTRIES,	SF NO.137/2,GANAPATHY NAGAR,ARIYAMANGALAM,TRICHY		
		19735	RENUKA FLUXES COMPANY,	3-227 - A, SEMMANKUDAL (PO),OMALUR TALUK,SALEM		04290 313331
		10081	ESAB INDIA LTD	KARUMUTTU CENTRE, 6TH FLOORNEW NO.634(OLD NO.498)ANNA SALAI, NANDANAM,CHENNAI-35CHENNAI	jagdeesh.ds@esab.co.in	044-826 9343
14791	ANAND ARC LTD.,	NO.22(OLD.31),RAILWAY COLONY,III STREET,AMINJIKARAI,CHENNAI		044 23746379		
15101	PRECISION WELDARC LTD,	49,B.T. ROAD, PANIHATI24,PARGANAS (NORTH)KOLKATA.	pwires@yahoo.co.in	033 25634753		

**SECTION - VIII
LIST OF APPROVED VENDORS**

1) WELDING CONSUMABLES SUPPLIERS LIST

Mat Group	Material Group Description	Vendor No	Vendor Name	Vendor Address	EMAIL	PHONE1
		11528	RAAJRATNA ELECTRODES LTD	11, SONAROOPA, OPP.LALBANGLOWC.G.ROAD, NAVARANGPURA AHMEDABAD	mktg@gnaht-rel.global.net.in	079 - 6445258
TIGA1	GTAW ROD - T92 / P92	21411	METRODE PRODUCTS LIMITED,	HANWORTH LANE,CHERTESSY,SURREY KT169LL,		
		20563	BOHLER SCHWEISSTECHNNIK	UNIONSTRASSE-1,D-59067 HAMM,DEUTSCHLAND GmbH.,GERMANY		
TIGA2	GTAW ROD ER80S-B3L	20563	BOHLER SCHWEISSTECHNNIK	UNIONSTRASSE-1,D-59067 HAMM,DEUTSCHLAND GmbH.,GERMANY		
		20047	KANEMATSU TRADING CORPORATION	6th FLOOR,AKEBONO NIHONBASHI BLDG,19 - 5,NIHONBASHIKOAMI-CHO,CHUO - KU, TOKYO, 103 - 0016.	nikko-bocki@kgt.kanematsu.co.jp	81 3 5283 3680
		21411	METRODE PRODUCTS LIMITED,	HANWORTH LANE,CHERTESSY,SURREY KT169LL,		
		22391	AIR-LIQUIDE WELDING FRANCE,	13,RUE D'EPLUCHES-BP70024 SAINT-OUEN L'AUMONE,95315 CERGY PONTOISE CEDEX	jean-paul.shmitt@airliquide.com	1342 13480
TIGS1	GTAW ROD ER316H	20067	UTP SCHWEISS MATERIAL GMBH & CO	ELSASSER STR 10D-79189, BAD KROZINGENGERMANY.		49(0) 07633 / 40
		20047	KANEMATSU TRADING CORPORATION	6th FLOOR,AKEBONO NIHONBASHI BLDG,19 - 5,NIHONBASHIKOAMI-CHO,CHUO - KU, TOKYO, 103 - 0016.	nikko-bocki@kgt.kanematsu.co.jp	81 3 5283 3680
		20130	ALCONIX CORPORATION	SANNO PARK TOWER,12TH FLOOR,2-11-1 NAGATA- CHO,CHIYODA-KU,TOKYO ,JAPAN	Inamori.khei@alconix.com	
TIGS2	GTAW ROD ER309L	20047	KANEMATSU TRADING CORPORATION	6th FLOOR,AKEBONO NIHONBASHI BLDG,19 - 5,NIHONBASHIKOAMI-CHO,CHUO - KU, TOKYO, 103 - 0016.	nikko-bocki@kgt.kanematsu.co.jp	81 3 5283 3680
		20130	ALCONIX CORPORATION	SANNO PARK TOWER,12TH FLOOR,2-11-1 NAGATA- CHO,CHIYODA-KU,TOKYO ,JAPAN	Inamori.khei@alconix.com	
		20067	UTP SCHWEISS MATERIAL GMBH & CO	ELSASSER STR 10D-79189, BAD KROZINGENGERMANY.		49(0) 07633 / 40
		22391	AIR-LIQUIDE WELDING FRANCE,	13,RUE D'EPLUCHES-BP70024 SAINT-OUEN L'AUMONE,95315 CERGY PONTOISE CEDEX	jean-paul.shmitt@airliquide.com	1342 13480
TIGS3	GTAW ROD ER308H	20130	ALCONIX CORPORATION	SANNO PARK TOWER,12TH FLOOR,2-11-1 NAGATA- CHO,CHIYODA-KU,TOKYO ,JAPAN	Inamori.khei@alconix.com	
		20047	KANEMATSU TRADING CORPORATION	6th FLOOR,AKEBONO NIHONBASHI BLDG,19 - 5,NIHONBASHIKOAMI-CHO,CHUO - KU, TOKYO, 103 - 0016.	nikko-bocki@kgt.kanematsu.co.jp	81 3 5283 3680
		20067	UTP SCHWEISS MATERIAL GMBH & CO	ELSASSER STR 10D-79189, BAD KROZINGENGERMANY.		49(0) 07633 / 40

**SECTION - VIII
LIST OF APPROVED VENDORS**

1) WELDING CONSUMABLES SUPPLIERS LIST

Mat Group	Material Group Description	Vendor No	Vendor Name	Vendor Address	EMAIL	PHONE1
TIGW1	ER 70S-A1 GTAW ROD	10774	D&H SECHERON ELECTRODES PVT LTD.	P.B.NO.344-46,INDL.ESTATE,KILAMAIDANINDORE	sales@dnhsecheron.net	0731-4229222
		20563	BOHLER SCHWEISSTECHNNIK	UNIONSTRASSE-1,D-59067 HAMM,DEUTSCHLAND GmbH.,GERMANY		
		20047	KANEMATSU TRADING CORPORATION	6th FLOOR,AKEBONO NIHONBASHI BLDG,19 - 5,NIHONBASHIKOAMI-CHO,CHUO - KU, TOKYO, 103 - 0016.	nikko-bocki@kgt.kanematsu.co.jp	81 3 5283 3680
		15083	MARUTHI ELECTRODES (P) LTD.,	138,5TH FLOOR,MARUTHI TOWERAIRPORT ROAD,KODIHALU,BANGALORE	meplelec@bgl.vsnl.net.in	080 25275848
		21411	METRODE PRODUCTS LIMITED,	HANWORTH LANE,CHERTESSY,SURREY KT169LL,		
		20011	BOHLER SCHWEISSTECHNIK AUSTRIA	WERK DEUCHENDORF,A 8605, KAPPENBERG, POSTFACH - 9,AUSTRIA.AUSTRIA.		0043/3862301
		22456	I.A.BARNES & CO. LTD,	UNIT E,GUNNELS WOOD PARK,GUNNELS WOOD ROAD,STEVENAGE, HERTFORDSHIRE, SG1 2BH,		
TIGW2	ER 80S-B2 GTAW ROD	20047	KANEMATSU TRADING CORPORATION	6th FLOOR,AKEBONO NIHONBASHI BLDG,19 - 5,NIHONBASHIKOAMI-CHO,CHUO - KU, TOKYO, 103 - 0016.	nikko-bocki@kgt.kanematsu.co.jp	81 3 5283 3680
		10774	D&H SECHERON ELECTRODES PVT LTD.	P.B.NO.344-46,INDL.ESTATE,KILAMAIDANINDORE	sales@dnhsecheron.net	0731-4229222
		21461	INDUSTRIA NAZIONALE ELETTRODI S.p.A	Via.FACCA 10,CITTADELLA, 35013ITALY.		
		21411	METRODE PRODUCTS LIMITED,	HANWORTH LANE,CHERTESSY,SURREY KT169LL,		
TIGW3	ER 90S-B3 GTAW ROD	21461	INDUSTRIA NAZIONALE ELETTRODI S.p.A	Via.FACCA 10,CITTADELLA, 35013ITALY.		
		20047	KANEMATSU TRADING CORPORATION	6th FLOOR,AKEBONO NIHONBASHI BLDG,19 - 5,NIHONBASHIKOAMI-CHO,CHUO - KU, TOKYO, 103 - 0016.	nikko-bocki@kgt.kanematsu.co.jp	81 3 5283 3680
		21411	METRODE PRODUCTS LIMITED,	HANWORTH LANE,CHERTESSY,SURREY KT169LL,		
		20563	BOHLER SCHWEISSTECHNNIK	UNIONSTRASSE-1,D-59067 HAMM,DEUTSCHLAND GmbH.,GERMANY		
TIGW4	WELDG.WIRE-TIG ER347	20067	UTP SCHWEISS MATERIAL GMBH & CO	ELSASSER STR 10D-79189, BAD KROZINGENGERMANY.		49(0) 07633 / 40
		21411	METRODE PRODUCTS LIMITED,	HANWORTH LANE,CHERTESSY,SURREY KT169LL,		
		20047	KANEMATSU TRADING CORPORATION	6th FLOOR,AKEBONO NIHONBASHI BLDG,19 - 5,NIHONBASHIKOAMI-CHO,CHUO - KU, TOKYO, 103 - 0016.	nikko-bocki@kgt.kanematsu.co.jp	81 3 5283 3680

**SECTION - VIII
LIST OF APPROVED VENDORS**

1) WELDING CONSUMABLES SUPPLIERS LIST

Mat Group	Material Group Description	Vendor No	Vendor Name	Vendor Address	EMAIL	PHONE1
		20563	BOHLER SCHWEISSTECHNNIK	UNIONSTRASSE-1,D-59067 HAMM,DEUTSCHLAND GmbH.,GERMANY		
TIGW5	WELDG.WIRE-TIG ERNiC	20067	UTP SCHWEISS MATERIAL GMBH & CO	ELSASSER STR 10D-79189, BAD KROZINGENGERMANY.		49(0) 07633 / 40
		15083	MARUTHI ELECTRODES (P) LTD.,	138,5TH FLOOR,MARUTHI TOWERAIRPORT ROAD,KODIHALU,BANGALORE	meplelec@bgl.vsnl.net.in	080 25275848
		20047	KANEMATSU TRADING CORPORATION	6th FLOOR,AKEBONO NIHONBASHI BLDG,19 - 5,NIHONBASHIKOAMI-CHO,CHUO - KU, TOKYO, 103 - 0016.	nikko-bocki@kgt.kanematsu.co.jp	81 3 5283 3680
		20563	BOHLER SCHWEISSTECHNNIK	UNIONSTRASSE-1,D-59067 HAMM,DEUTSCHLAND GmbH.,GERMANY		
TIGW7	WELDG.WIRE - TIG ER9	20047	KANEMATSU TRADING CORPORATION	6th FLOOR,AKEBONO NIHONBASHI BLDG,19 - 5,NIHONBASHIKOAMI-CHO,CHUO - KU, TOKYO, 103 - 0016.	nikko-bocki@kgt.kanematsu.co.jp	81 3 5283 3680
		22391	AIR-LIQUIDE WELDING FRANCE,	13,RUE D'EPLUCHES-BP70024 SAINT-OUEN L'AUMONE,95315 CERGY PONTOISE CEDEX	jean-paul.shmitt@airliquide.com	1342 13480
		20011	BOHLER SCHWEISSTECHNIK AUSTRIA	WERK DEUCHENDORF,A 8605, KAPPENBERG, POSTFACH - 9,AUSTRIA.AUSTRIA.		0043/3862301
		20563	BOHLER SCHWEISSTECHNNIK	UNIONSTRASSE-1,D-59067 HAMM,DEUTSCHLAND GmbH.,GERMANY		
		21411	METRODE PRODUCTS LIMITED,	HANWORTH LANE,CHERTESSY,SURREY KT169LL,		
TIGW9	ER80S - D2 GTAW ROD	20563	BOHLER SCHWEISSTECHNNIK	UNIONSTRASSE-1,D-59067 HAMM,DEUTSCHLAND GmbH.,GERMANY		
		21411	METRODE PRODUCTS LIMITED,	HANWORTH LANE,CHERTESSY,SURREY KT169LL,		
		20130	ALCONIX CORPORATION	SANNO PARK TOWER,12TH FLOOR,2-11-1 NAGATA-CHO,CHIYODA-KU,TOKYO ,JAPAN	Inamori.khei@alconix.com	
TIGWA	GTAW ROD T23 / P23	20047	KANEMATSU TRADING CORPORATION	6th FLOOR,AKEBONO NIHONBASHI BLDG,19 - 5,NIHONBASHIKOAMI-CHO,CHUO - KU, TOKYO, 103 - 0016.	nikko-bocki@kgt.kanematsu.co.jp	81 3 5283 3680
		21411	METRODE PRODUCTS LIMITED,	HANWORTH LANE,CHERTESSY,SURREY KT169LL,		
		20563	BOHLER SCHWEISSTECHNNIK	UNIONSTRASSE-1,D-59067 HAMM,DEUTSCHLAND GmbH.,GERMANY		
		20130	ALCONIX CORPORATION	SANNO PARK TOWER,12TH FLOOR,2-11-1 NAGATA-CHO,CHIYODA-KU,TOKYO ,JAPAN	Inamori.khei@alconix.com	
TIGWR	GTAW ROD SUPER304H	20563	BOHLER SCHWEISSTECHNNIK	UNIONSTRASSE-1,D-59067 HAMM,DEUTSCHLAND GmbH.,GERMANY		

**SECTION - VIII
LIST OF APPROVED VENDORS**

1) WELDING CONSUMABLES SUPPLIERS LIST

Mat Group	Material Group Description	Vendor No	Vendor Name	Vendor Address	EMAIL	PHONE1
TIGWB	GTAW ROD SUPERSONIC	20130	ALCONIX CORPORATION	SANNO PARK TOWER,12TH FLOOR,2-11-1 NAGATA-CHO,CHIYODA-KU,TOKYO ,JAPAN	Inamori.khei@alconix.com	
TIGWD	GTAW ROD	20047	KANEMATSU TRADING CORPORATION	6th FLOOR,AKEBONO NIHONBASHI BLDG,19 - 5,NIHONBASHIKOAMI-CHO,CHUO - KU, TOKYO, 103 - 0016.	nikko-bocki@kgt.kanematsu.co.jp	81 3 5283 3680
		21991	SPECIAL METALS WELDING PRODUCTS	1401,BURRIS ROAD,NEWTON,NORTH COROLINA 28658	rphillips@smwpc.com	828-465-0352
WCA08	WELDG.ELECTRODES:SMA	10774	D&H SECHERON ELECTRODES PVT LTD.	P.B.NO.344-46,INDL.ESTATE,KILAMAIDANINDORE	sales@dnhsecheron.net	0731-4229222
		15090	RAJ KESARI ELECTRODES,	35,RAVINDRA NAGAR,(PRATAP NAGAR)UDAIPUR	rajkesari@yahoo.com	0294 2490193
WCA10	WELDG.ELECTRODES:SMA	14040	MANTEK ELECTRODS PRIVATE LTD,	D-74A, DEVELOPED PLOT ESTATE,THUVAKUDITRICHY		2501540
		13690	GEE LIMITED,	PLOT E-1, ROAD NO. 7,WAGLE INDUSTRIAL ESTATETHANE		
		18705	MODI HITECH INDIA LTD.,	1400,MODI TOWER98,NEHRU PLACE,NEW DELHI	gmmelectrode@gmail.com	011 4250 4577
		10774	D&H SECHERON ELECTRODES PVT LTD.	P.B.NO.344-46,INDL.ESTATE,KILAMAIDANINDORE	sales@dnhsecheron.net	0731-4229222
		11227	HONAVAR ELECTRODES PVT. LTD.,	305-309,3RD FLOOR,DAMJI SHAMJI INDUSTRIAL COMPLEX ,9,L.B.S MARG, KURLA(WEST)MUMBAI	hel@vsnl.com	022-25020317
		11378	MAILAM INDIA LIMITED	MAILAM MAIN ROAD,SEDARAPET,PONDICHERRY	mailam@mailanindia.com	0413-2677311
		11420	MODI ARC ELECTRODES CO.	MODINAGARUTTAR PRADESHGHAZIABAD	modiarc@ndb.vsnl.net.in	01232 - 242427
WCA12	WELDG.ELECTRODES:SMA	10774	D&H SECHERON ELECTRODES PVT LTD.	P.B.NO.344-46,INDL.ESTATE,KILAMAIDANINDORE	sales@dnhsecheron.net	0731-4229222
		11227	HONAVAR ELECTRODES PVT. LTD.,	305-309,3RD FLOOR,DAMJI SHAMJI INDUSTRIAL COMPLEX ,9,L.B.S MARG, KURLA(WEST)MUMBAI	hel@vsnl.com	022-25020317
		13690	GEE LIMITED,	PLOT E-1, ROAD NO. 7,WAGLE INDUSTRIAL ESTATETHANE		
		11420	MODI ARC ELECTRODES CO.	MODINAGARUTTAR PRADESHGHAZIABAD	modiarc@ndb.vsnl.net.in	01232 - 242427
		11378	MAILAM INDIA LIMITED	MAILAM MAIN ROAD,SEDARAPET,PONDICHERRY	mailam@mailanindia.com	0413-2677311
		20011	BOHLER SCHWEISSTECHNIK AUSTRIA	WERK DEUCHENDORF,A 8605, KAPPENBERG, POSTFACH - 9,AUSTRIA.AUSTRIA.		0043/3862301

**SECTION - VIII
LIST OF APPROVED VENDORS**

1) WELDING CONSUMABLES SUPPLIERS LIST

Mat Group	Material Group Description	Vendor No	Vendor Name	Vendor Address	EMAIL	PHONE1
WCA23	SMAW ELECTRODE E9015	20047	KANEMATSU TRADING CORPORATION	6th FLOOR,AKEBONO NIHONBASHI BLDG,19 - 5,NIHONBASHIKOAMI-CHO,CHUO - KU, TOKYO, 103 - 0016.	nikko-bocki@kgt.kanematsu.co.jp	81 3 5283 3680
		21411	METRODE PRODUCTS LIMITED,	HANWORTH LANE,CHERTESSY,SURREY KT169LL,		
		22391	AIR-LIQUIDE WELDING FRANCE,	13,RUE D'EPLUCHES-BP70024 SAINT-OUEN I'AUMONE,95315 CERGY PONTOISE CEDEX	jean-paul.shmitt@airliquide.com	1342 13480
		20563	BOHLER SCHWEISSTECHNIK	UNIONSTRASSE-1,D-59067 HAMM,DEUTSCHLAND GmbH.,GERMANY		
WCA24	SMAW ELECTRD T23/P23	21411	METRODE PRODUCTS LIMITED,	HANWORTH LANE,CHERTESSY,SURREY KT169LL,		
		20047	KANEMATSU TRADING CORPORATION	6th FLOOR,AKEBONO NIHONBASHI BLDG,19 - 5,NIHONBASHIKOAMI-CHO,CHUO - KU, TOKYO, 103 - 0016.	nikko-bocki@kgt.kanematsu.co.jp	81 3 5283 3680
		20130	ALCONIX CORPORATION	SANNO PARK TOWER,12TH FLOOR,2-11-1 NAGATA-CHO,CHIYODA-KU,TOKYO ,JAPAN	Inamori.khei@alconix.com	
WCA25	SMAW ELECD - T92/P92	21411	METRODE PRODUCTS LIMITED,	HANWORTH LANE,CHERTESSY,SURREY KT169LL,		
		20563	BOHLER SCHWEISSTECHNIK	UNIONSTRASSE-1,D-59067 HAMM,DEUTSCHLAND GmbH.,GERMANY		
WCA26	SMAW ELEC E8018-B3L	10774	D&H SECHERON ELECTRODES PVT LTD.	P.B.NO.344-46,INDL.ESTATE,KILAMAIDANINDORE	sales@dnhsecheron.net	0731-4229222
		11227	HONAVAR ELECTRODES PVT. LTD.,	305-309,3RD FLOOR,DAMJI SHAMJI INDUSTRIAL COMPLEX ,9,L.B.S MARG, KURLA(WEST)MUMBAI	hel@vsnl.com	022-25020317
WCA27	SMAW ELEC E7018-B2L	11227	HONAVAR ELECTRODES PVT. LTD.,	305-309,3RD FLOOR,DAMJI SHAMJI INDUSTRIAL COMPLEX ,9,L.B.S MARG, KURLA(WEST)MUMBAI	hel@vsnl.com	022-25020317
		10774	D&H SECHERON ELECTRODES PVT LTD.	P.B.NO.344-46,INDL.ESTATE,KILAMAIDANINDORE	sales@dnhsecheron.net	0731-4229222
		15080	SUNCRAFT ELECTRODES	BYE PASS ROAD,MUSIRI		04326 60525
		15085	VOLTARC ELECTRODES (P) LTD,	10-77, FIRST MAIN,ROYAL NAGAR,H.O.SURYAJYOTHI,R.C.ROAD, P.B.NO.33,TIRUPATHI	voltarc@rediffmail.com	0877 2241462
		18433	NUCOR WELD(INDIA)PVT.LTD.,	NO.223,KONAPPANA AGRAHARA,ELECTRONIC CITY POST,BANGALORE	nuکورweldinida@yahoo.com	080-2852 2057
		15083	MARUTHI ELECTRODES (P) LTD.,	138,5TH FLOOR,MARUTHI TOWERAIRPORT ROAD,KODIHALU,BANGALORE	mepolec@bgl.vsnl.net.in	080 25275848

**SECTION - VIII
LIST OF APPROVED VENDORS**

1) WELDING CONSUMABLES SUPPLIERS LIST

Mat Group	Material Group Description	Vendor No	Vendor Name	Vendor Address	EMAIL	PHONE1
		11881	FUSION ENGG. PRODUCTS LTD.,	B-16,Vith PHASE, POST.GAMARIA(JAMSHEDPUR)SERAIKELA- KHARSAWAN,GAMARIA	info@fusionweld.co.in	0657-6542444
		13538	WELDCOM ELECTRODES PVT.LTD.,	T-357,ASHIRWAD PALACENR.BHATAR CHAR RASTA,JIVKOR NAGAR,SURAT		0261-305 4555
		13693	RASI ELECTRODES LTD.,	21, RAJA ANNAMALAI ROAD,FLAT NO A / 14, THIRD FLOOR,CHENNAI	rele@airtelmail.in	044 26424523
		15102	SOLARC WELD RODS,	OLD NO.12,NEW NO.14,65th STREET12th AVENUE,ASHOK NAGAR,CHENNAI	soarcweldrods@gmail.com	044-24891173
		15081	ANNAI SIVAKAMI AMMAL INDUSTRIES,	5/1C,M.M.K.COMPLEX,(OPP. TO S.I.T.)ARIYAMANGALAM.TIRUCHIRAPALLY		0431 2441696
		11378	MAILAM INDIA LIMITED	MAILAM MAIN ROAD,SEDARAPET,PONDICHERRY	mailam@mailanindia.com	0413-2677311
		13663	ORION WIRE MANUFACTURING CO.,	POST BOX NO.7,PLOT NO.56A & 44A,GIDC ESTATE,NARNADA NAGAR,BHARUCH	info@sunarcindia.com	02462-246419
		17820	SETH ELECTRODES PVT. LTD.,	SHRIMANT BHAWAN,KHURAI	sepl@sethindia.com	07581 240704
		11380	MALU ELECTRODES PVT.LIMITED	111, RAMAKRISHNA APPARTMENT,CHHAPRU NAGAR SQUARE,CENTRAL AVENUE NAGAR,NAGPUR	meploffice@rediffmail.com	0712 - 2734895
		11420	MODI ARC ELECTRODES CO.	MODINAGARUTTAR PRADESHGHAZIABAD	modiarc@ndb.vsnl.net.in	01232 - 242427
		17661	ALPHA WELDING & ALLIED	#B-10,VEERASANDRA INDUSTRIALESTATE, HOSUR ROAD,BANGALORE		
		17664	ELMARC ELECTRODES PVT. LTD.,	118,SISIDCO INDUSTRIAL ESTATE,AMBATTUR,CHENNAI		
		17813	K.M.CROWN WELDING CONSUMABLES PVT.,	BLOCK NO.16A,16B & 17A,INDUSTRIAL AREA NO.1,A.B.ROAD,DEWAS	kmcrownwelding@dataone.com	07272 259384578
		17812	VICTOR ELECTRODES LIMITED ,	T-1/ 113-114,MANGOLPURI INDUSTRIAL AREA,PHASE - I,NEW DELHI	victor@del2.vsnl.net.in	011 43860025
		17802	SRI VARSHA ELECTRODES,	SHED NO. 55,PHASE V,SIDCO INDUSTRIAL ESTATE,KAKKALUR,THIRUVALLUR DIST.CHENNAI		0 98402 60618
		17643	SUNDEEP ELECTRODES PVT. LTD.,	BULANSHAHAR ROAD,HAPUR		
		17801	JAIN WELDING ELECTRODES PVT. LTD,	G-1-318(C).INDRAPRASTHA INDUSTRIAL AREA,ROAD NO.6,RAJASTHAN,KOTA	info@jainelectrodes.com	0744 2490177
		11227	HONAVAR ELECTRODES PVT. LTD.,	305-309,3RD FLOOR,DAMJI SHAMJI INDUSTRIAL COMPLEX ,9,L.B.S MARG, KURLA(WEST)MUMBAI	hel@vsnl.com	022-25020317

**SECTION - VIII
LIST OF APPROVED VENDORS**

1) WELDING CONSUMABLES SUPPLIERS LIST

Mat Group	Material Group Description	Vendor No	Vendor Name	Vendor Address	EMAIL	PHONE1
WCC01	WELDG.ELECTRODES:SMA	13729	ORANGE ELECTRODES INDUSTRIES,	PLOT NO.9,SHIV SHAKTI LAGHU UDYOGSANKUL,OPP.NEEL ENGG.CO.MUMBAI-NASIK HIGHWAY,ASANGAON	orangeelectrodes@gmail.com	02527-271 995
		13690	GEE LIMITED,	PLOT E-1, ROAD NO. 7,WAGLE INDUSTRIAL ESTATETHANE		
		15087	V.N.C.ELECTRODEES,	3, INDUSTRIAL ESTATE,S.VELLALAPATTIKARUR	kru_vnc@sancharnet.in	04324 242774
		19906	BAGHERWAL ELECTRODES PVT.LTD.,	20-23,VAIBHAV CHAMBER,7/1,USHAGANJ CHHAWANI,INDORE	bagherwal13@yahoo.com	0731-2905067
		13986	B&H ELECTRODES PVT. LTD,	VILLAGE SAIDPURA, BARWALA ROAD,DERABASSI,MOHALI		
		10081	ESAB INDIA LTD	KARUMUTTU CENTRE, 6TH FLOORNEW NO.634(OLD NO.498)ANNA SALAI, NANDANAM,CHENNAI-35CHENNAI	jagdeesh.ds@esab.co.in	044-826 9343
		19875	ABIRAMI ELECTRODES,	SF NO.107-A,SARAVANAMPATTI ROAD,VELLAIKINARU,COIMBATORE	sun_weld@yahoo.com	0422 3232724
		14457	BALAJI ELECTRODES	4A / 1A, N.G. NARAYANASAMY STREET,NEW SIDHAPUDUR (PO),COIMBATORE.	sonyaarc6013@gmail.com	0422 438 7817
		19751	FINE WELD ELECTRODESS INDIA (P)LTD.	2/630,PERUMAL KOIL THOTTAM,VENKATAPURAM (PO),COIMBATORE	fineweldcbe@yahoo.com	0422-6581990/...
		19745	MEGA WELD TECHNOLOGIES,	3/219,AVINASHI ROAD,NEELAMBUR (PO),COIMBATORE	megaweldcbe@yahoo.com	0422-658 1989
		14449	IDEAL ELECTRODES	7 - A, SITRA ROAD,KALAPPATTI,COIMBATORE.	idealelectrode@gmail.com	0422 262 7710
		14447	UPARC ELECTRODES COMPANY.	BEHIND NAV BHARAT INTER COLLEGE,KHASRA No.1, INDIRA PURAM COLONY,PARTAPUR,MEERUT.		0121 244 0203
		10667	EUREKA SYSTEMS AND ELECTRODES P.LTD	11/15A,SELVARAJAPURAM,CHINTHAMANIPUDUR, COIMBATORE	info@eurekaelectrodes@gmail.com	0422-268 7199...
		12893	RUKHMANI ELECTRODES PVT.LTD.,	31,THAKURPUKUR (N.W) ROAD,P.O.BADU,DIST:24 PARGANAS(N)KOLKATA	rukhmanielectrodes@rediffmail.com	033-2526 2039
		14448	BRIGHT WELD TECHNOLOGIES	9 / 9, SAKTHI NAGAR,UPPILIPALAYAM POST,COIMBATORE.	brigtweld13@gmail.com	0422 257 4756
		10785	ADOR WELDING LIMITED	CORPORATE MARKETING OFFICE,P.B. NO. 2, CHINCHWAD,PUNE	acegasindia@gamil.com	
15086	SRI RENGA ELECTRODES (P) LTD,	137/3, GANAPATHY NAGAR,ARIYAMANGALAMTRICHY		0431-25501173		

**SECTION - VIII
LIST OF APPROVED VENDORS**

1) WELDING CONSUMABLES SUPPLIERS LIST

Mat Group	Material Group Description	Vendor No	Vendor Name	Vendor Address	EMAIL	PHONE1
		13911	ROYAL ARC ELECTRODES PVT. LTD	ROYAL HOUSE, PLOT NO.26,VILLAGE VALIV,VASAI (EAST)THANE	royalarc@vsnl.com	0250 2480520
		11528	RAAJRATNA ELECTRODES LTD	11, SONAROOA, OPP.LALBANGLOWC.G.ROAD, NAVARANGPURAAHMEDABAD	mktg@gnahd-rel.global.net.in	079 - 6445258
		17644	VARUN ELECTRODES PVT. LTD.,	H-56,INDUSTRIAL AREA,PANIPAT	kapoor@varunelectrodes.com	0180 2653085
		17814	CALCUTTA ELECTRODES PVT. LTD.,	SARDAR PATEL TIMBER MARKET,BHANPURI,RAIPUR	calcutta_electrodes2006@yahoo.com	0771 4090615
		19111	SPECTRA SUPER ALLOYS LTD,	324 / 325, 3RD FLOOR,ASHIANA TRADE CENTER,ADITYAPUR,JAMSHEDPUR	ss_alloys@yahoo.co.in	0657 6577148
		18846	COSMOS ELECTRODES PVT., LTD,	9/2,KIBE COMPOUND,CHHOTI GEALTOLI CHOURAHA,INDORE		0731 2707946
		18705	MODI HITECH INDIA LTD.,	1400,MODI TOWER98,NEHRU PLACE,NEW DELHI	gmmelectrode@gmail.com	011 4250 4577
		10758	ALPHA ARC INDUSTRIES,	B-5,SECTOR A5/6 TRONICA CITYLONIGHAZIABAD, UP	alphaarc@yahoo.com	0 99114 41441
		18300	SUPERON SCHWEISSTECHNIK INDIA LTD.,	191-D,SECTOR-IV,PHASE-II,IMT MANESAR,GURGAON,HARYANA		011-24647199
		15089	WELDCRAFT PRIVATE LIMITED,	72, INDUSTRIAL SUBURB,2ND STAGE, TUMKUR ROAD,BANGALORE.	weldcraft@vsnl.net	080 3373351
		18597	SHIELDARC EQUIPMENTS PVT. LTD,	85,ELLIOT ROAD,KOLKATA		
		18540	KOLLIPARA ELECTRODES PVT.LTD.,	KRISHNA NAGAR,PENAMALURUKRISHNA DIST.(AP)		
		14575	WELD ALLOY PRODUCTS,	C - 33, SECTOR - IV, NOIDANOIDA DIST.GAUTAM BUDH NAGAR (UP)	wap2005@airtelmail.in	0120-2557183
		14429	ALPHA FLUX & ELETRODES,	178/2-A2,THURAIYUR ROAD,PULIVALAM, MUSIRI - T.K.TRICHY DISTRICT	t.vasanthan@sify.com	04327 294169
		13211	D&H INDIA LIMITED	PLOT 'A', SECTOR 'A'INDUSTRIAL AREA,SANWER ROADINDORE	dhindia@sancharnet.in	0731-4273501-...
		14040	MANTEK ELECTRODS PRIVATE LTD,	D-74A, DEVELOPED PLOT ESTATE,THUVAKUDITRICHY		2501540
		13906	MARUTI WELD LIMITED,	I-1, KIRTI NAGARNEW DELHI	marutiweld@marutiweld.com	25913411
		13763	CLASSIC ELECTRODES (INDIA) LTD.,	1, BONFIELD LANE2 ND FLOORKOLKATA	classicelectrodes@yahoo.co.in	033 22429581
		15088	NIVETHA ELECTRODES,	195,PUDUKKOTTAI ROAD,TAMILNADU TANNREY'S BUILDING,SEMPATTU,TIRUCHIRAPALLY		0431 2341377
		10774	D&H SECHERON ELECTRODES PVT LTD.	P.B.NO.344-46,INDL.ESTATE,KILAMAIDANINDORE	sales@dnhsecheron.net	0731-4229222
		13549	ATHARVE WELDING TECHNOLOGIES (INDIA	PVT.LTD.,A 192,M.I.D.C.CHINCHOLI,SOLAPUR	atharv.wt@hotmail.com	0217-273 7029

**SECTION - VIII
LIST OF APPROVED VENDORS**

1) WELDING CONSUMABLES SUPPLIERS LIST

Mat Group	Material Group Description	Vendor No	Vendor Name	Vendor Address	EMAIL	PHONE1
		13487	MAGNARC ELECTRODES PVT.LTD.,	PENDUTHIVISAGAPATNAM	magnarc@hotmail.com	0891-276 4381...
		14523	JINDAL DUROWELD	BN / 19 & 20,KALUNGA INDL. ESTATE,ROURKELA.	jdplrkl@yahoo.co.in	0661 266 0621
		15082	ROYAL WELDING WIRES PVT. LTD.,	7,KARANAI PUDUCHERRY VILLAGE,VIA.URAPAKKAM,KANCHIPURAM DIST,	royal@royalwires.co.in	044-3741 1610
		15090	RAJ KESARI ELECTRODES,	35,RAVINDRA NAGAR,(PRATAP NAGAR)UDAIPUR	rajkesari@yahoo.com	0294 2490193
		14584	SUN ELECTRODE	SF No.119/3, RAYAMUNDANPATTI,PUDHUKUDI ROAD,TANJORE.	sunenterprises2011@gmail.com	0 88256 36464
		14534	AARYA ELECTRODES PVT.LTD.	JOHN'S MILL NO.3,JEONI MANDI,AGRA.	vibhor@aaryaelectrodes.com	0562 262 2121
		18433	NUCOR WELD(INDIA)PVT.LTD.,	NO.223,KONAPPANA AGRAHARA,ELECTRONIC CITY POST,BANGALORE	nucorweldinida@yahoo.com	080-2852 2057
		18846	COSMOS ELECTRODES PVT., LTD,	9/2,KIBE COMPOUND,CHHOTI GEALTOLI CHOURAHA,INDORE		0731 2707946
		13487	MAGNARC ELECTRODES PVT.LTD.,	PENDUTHIVISAGAPATNAM	magnarc@hotmail.com	0891-276 4381...
		11380	MALU ELECTRODES PVT.LIMITED	111, RAMAKRISHNA APPARTMENT,CHHAPRU NAGAR SQUARE,CENTRAL AVENUE NAGAR,NAGPUR	meploffice@rediffmail.com	0712 - 2734895
		11227	HONAVAR ELECTRODES PVT. LTD.,	305-309,3RD FLOOR,DAMJI SHAMJI INDUSTRIAL COMPLEX ,9,L.B.S MARG, KURLA(WEST)MUMBAI	hel@vsnl.com	022-25020317
		15102	SOLARC WELD RODS,	OLD NO.12,NEW NO.14,65th STREET12th AVENUE,ASHOK NAGAR,CHENNAI	soarcweldrods@gmail.com	044-24891173
		15086	SRI RENGHA ELECTRODES (P) LTD,	137/3, GANAPATHY NAGAR,ARIYAMANGALAMTRICHY		0431-25501173
		18432	VIJEY ELECTRODES AND WIRES PVT.	83/1,THIRUNEERMALAI ROAD,NAGELKENI, CHROMPET,CHENNAI	vjelect@yahoo.co.in	044-2238 1098
		19305	MURLI ELECTRODE PVT. LTD,	EL. 30,M.I.D.C.INDUSTRIAL ESTATE,HINGNA ROAD,NAGPUR	sudhir_0408@rediffmail.com	0712 2769347
		18540	KOLLIPARA ELECTRODES PVT.LTD.,	KRISHNA NAGAR,PENAMALURUKRISHNA DIST.(AP)		
		18705	MODI HITECH INDIA LTD.,	1400,MODI TOWER98,NEHRU PLACE,NEW DELHI	gmmelectrode@gmail.com	011 4250 4577
		15085	VOLTARC ELECTRODES (P) LTD,	10-77, FIRST MAIN,ROYAL NAGAR,H.O.SURYAJYOTHI,R.C.ROAD, P.B.NO.33,TIRUPATHI	voltarc@rediffmail.com	0877 2241462

**SECTION - VIII
LIST OF APPROVED VENDORS**

1) WELDING CONSUMABLES SUPPLIERS LIST

Mat Group	Material Group Description	Vendor No	Vendor Name	Vendor Address	EMAIL	PHONE1
WCC05	WELDG.ELECTRODES:SMA	15091	MAGNA ENGINEERING	CHINNAVUTAPALLIGANAVARAM MANDAL,VIJAYAWADA		08676 252181
		11378	MAILAM INDIA LIMITED	MAILAM MAIN ROAD,SEDARAPET,PONDICHERRY	mailam@mailanindia.com	0413-2677311
		17643	SUNDEEP ELECTRODES PVT. LTD.,	BULANSHAHAR ROAD,HAPUR		
		13763	CLASSIC ELECTRODES (INDIA) LTD.,	1, BONFIELD LANE2 ND FLOORKOLKATA	classicelectrodes@yahoo.co.in	033 22429581
		16548	WELD EXCEL INDIA LTD.,	D-230,PHASE VII,FOCAL POINT,LUDHIANA		
		10758	ALPHA ARC INDUSTRIES,	B-5,SECTOR A5/6 TRONICA CITYLONIGHAZIABAD, UP	alphaarc@yahoo.com	0 99114 41441
		12893	RUKHMANI ELECTRODES PVT.LTD.,	31,THAKURPUKUR (N.W) ROAD,P.O.BADU,DIST:24 PARGANAS(N)KOLKATA	rukhmanielectrodes@rediffmail.com	033-2526 2039
		18300	SUPERON SCHWEISSTECHNIK INDIA LTD.,	191-D,SECTOR-IV,PHASE-II,IMT MANESAR,GURGAON,HARYANA		011-24647199
		10785	ADOR WELDING LIMITED	CORPORATE MARKETING OFFICE,P.B. NO. 2, CHINCHWAD,PUNE	acegasindia@gamil.com	
		14575	WELD ALLOY PRODUCTS,	C - 33, SECTOR - IV, NOIDANOIDA DIST.GAUTAM BUDH NAGAR (UP)	wap2005@airtelmail.in	0120-2557183
		15083	MARUTHI ELECTRODES (P) LTD.,	138,5TH FLOOR,MARUTHI TOWERAIRPORT ROAD,KODIHALU,BANGALORE	meplelec@bgl.vsnl.net.in	080 25275848
		15089	WELDCRAFT PRIVATE LIMITED,	72, INDUSTRIAL SUBURB,2ND STAGE, TUMKUR ROAD,BANGALORE.	weldcraft@vsnl.net	080 3373351
		13906	MARUTI WELD LIMITED,	I-1, KIRTI NAGARNEW DELHI	marutiweld@marutiweld.com	25913411
		15082	ROYAL WELDING WIRES PVT. LTD.,	7,KARANAI PUDUCHERRY VILLAGE,VIA.URAPAKKAM,KANCHIPURAM DIST,	royal@royalwires.co.in	044-3741 1610
		13211	D&H INDIA LIMITED	PLOT 'A', SECTOR 'A'INDUSTRIAL AREA,SANWER ROADINDORE	dhindia@sancharnet.in	0731-4273501-...
		13911	ROYAL ARC ELECTRODES PVT. LTD	ROYAL HOUSE, PLOT NO.26,VILLAGE VALIV,VASAI (EAST) THANE	royalarc@vsnl.com	0250 2480520
		17813	K.M.CROWN WELDING CONSUMABLES PVT.,	BLOCK NO.16A,16B & 17A,INDUSTRIAL AREA NO.1,A.B.ROAD,DEWAS	kmcrownwelding@dataone.com	07272 259384578
		13388	THE INDIAN SEEL & WIRE PRODUCTS LTD	PO INDIRA NAGAR,JAMSHEDPUR - 831 008JHARKAND	upshar@tatasteel.com	0657- 6512744
		14791	ANAND ARC LTD.,	NO.22(OLD.31),RAILWAY COLONY,III STREET,AMINJIKARAI,CHENNAI		044 23746379
		10667	EUREKA SYSTEMS AND ELECTRODES P.LTD	11/15A,SELVARAJAPURAM,CHINTHAMANIPUDUR, COIMBATORE	info@eurekaelectrodes@gmail.com	0422-268 7199...

**SECTION - VIII
LIST OF APPROVED VENDORS**

1) WELDING CONSUMABLES SUPPLIERS LIST

Mat Group	Material Group Description	Vendor No	Vendor Name	Vendor Address	EMAIL	PHONE1
		15087	V.N.C.ELECTRODEES,	3, INDUSTRIAL ESTATE,S.VELLALAPATTIKARUR	kru_vnc@sancharnet.in	04324 242774
		11881	FUSION ENGG. PRODUCTS LTD.,	B-16,Vith PHASE, POST.GAMARIA(JAMSHEDPUR)SERAIKELA- KHARSAWAN,GAMARIA	info@fusionweld.co.in	0657-6542444
		15084	DWEKAM ELECTRODES LTD,	TALAWALI CHANDA,A.B.ROAD, P.O.MANGILAINDORE (MP)	vk.khandelwal@dwekam.org	0731 422 9500...
		17814	CALCUTTA ELECTRODES PVT. LTD.,	SARDAR PATEL TIMBER MARKET,BHANPURI,RAIPUR	calcutta_electrodes2006@yahoo.com	0771 4090615
		17644	VARUN ELECTRODES PVT. LTD.,	H-56,INDUSTRIAL AREA,PANIPAT	kapoor@varunelectrodes.com	0180 2653085
		14040	MANTEK ELECTRODS PRIVATE LTD,	D-74A, DEVELOPED PLOT ESTATE,THUVAKUDITRICHY		2501540
		15833	THIRUMALA ELECTRODES CO.,	S1-17B,'S' TYPE,SIDCO INDUSTRIAL ESTATE,THUVAKUDI,TRICHY	tec_sevenarcs@yahoo.co.in	0431-6573566
		17451	WELDWELL ELECTRODES,	D-59 M.I.D.C.,HINGNA INDUSTRIAL AREA,NAGPUR	weldwellngp@gmail.com	07104 232211/...
		13693	RASI ELECTRODES LTD.,	21, RAJA ANNAMALAI ROAD,FLAT NO A / 14, THIRD FLOOR,CHENNAI	rele@airtellmail.in	044 26424523
		11420	MODI ARC ELECTRODES CO.	MODINAGARUTTAR PRADESHGHAZIABAD	modiarc@ndb.vsnl.net.in	01232 - 242427
		19111	SPECTRA SUPER ALLOYS LTD,	324 / 325, 3RD FLOOR,ASHIANA TRADE CENTER,ADITYAPUR,JAMSHEDPUR	ss_alloys@yahoo.co.in	0657 6577148
		15090	RAJ KESARI ELECTRODES,	35,RAVINDRA NAGAR,(PRATAP NAGAR)UDAIPUR	rajkesari@yahoo.com	0294 2490193
		11528	RAAJRATNA ELECTRODES LTD	11, SONAROOPA, OPP.LALBANGLOWC.G.ROAD, NAVARANGPURA AHMEDABAD	mktg@gnahd-rel.global.net.in	079 - 6445258
		10081	ESAB INDIA LTD	KARUMUTTU CENTRE, 6TH FLOORNEW NO.634(OLD NO.498)ANNA SALAI, NANDANAM,CHENNAI-35CHENNAI	jagdeesh.ds@esab.co.in	044-826 9343
		19906	BAGHERWAL ELECTRODES PVT.LTD.,	20-23,VAIBHAV CHAMBER,7/1,USHAGANJ CHHAWANI,INDORE	bagherwal13@yahoo.com	0731-2905067
		10774	D&H SECHERON ELECTRODES PVT LTD.	P.B.NO.344-46,INDL.ESTATE,KILAMAIDANINDORE	sales@dnhsecheron.net	0731-4229222
		13690	GEE LIMITED,	PLOT E-1, ROAD NO. 7,WAGLE INDUSTRIAL ESTATETHANE		
		18432	VIJEY ELECTRODES AND WIRES PVT.	83/1,THIRUNEERMALAI ROAD,NAGELKENI, CHROMPET,CHENNAI	vjelect@yahoo.co.in	044-2238 1098
		11378	MAILAM INDIA LIMITED	MAILAM MAIN ROAD,SEDARAPET,PONDICHERRY	mailam@mailanindia.com	0413-2677311

**SECTION - VIII
LIST OF APPROVED VENDORS**

1) WELDING CONSUMABLES SUPPLIERS LIST

Mat Group	Material Group Description	Vendor No	Vendor Name	Vendor Address	EMAIL	PHONE1
WCC06	WELDG.ELECTRODES:SMA	10774	D&H SECHERON ELECTRODES PVT LTD.	P.B.NO.344-46,INDL.ESTATE,KILAMAIDANINDORE	sales@dnhsecheron.net	0731-4229222
		11227	HONAVAR ELECTRODES PVT. LTD.,	305-309,3RD FLOOR,DAMJI SHAMJI INDUSTRIAL COMPLEX ,9,L.B.S MARG, KURLA(WEST)MUMBAI	hel@vsnl.com	022-25020317
		13690	GEE LIMITED,	PLOT E-1, ROAD NO. 7,WAGLE INDUSTRIAL ESTATETHANE		
WCC09	Welding Consumable	20130	ALCONIX CORPORATION	SANNO PARK TOWER,12TH FLOOR,2-11-1 NAGATA-CHO,CHIYODA-KU,TOKYO ,JAPAN	Inamori.khei@alconix.com	
WCF01	WELDG.WIRE:FLUX CORE	21065	HYUNDAI WELDING CO. LTD.,	15F, 137-37 GANGNAM KU,INSONG BUILDING,SAMSUNG DONG,SEOUL	alex@hdweld.co.kr	82-02 6230-6077
		20970	THE SHANGHAI LINCOLN ELECTRIC	LANE 5008,HU TAI ROAD,BOASHAN, SHANGAI-201907		86 21 560 26664
		20047	KANEMATSU TRADING CORPORATION	6th FLOOR,AKEBONO NIHONBASHI BLDG,19 - 5,NIHONBASHIKOAMI-CHO,CHUO - KU, TOKYO, 103 - 0016.	nikko-bocki@kgt.kanematsu.co.jp	81 3 5283 3680
		91270	VEEPEES INDIA,	C-52, 4TH AVENUE ROAD,GUINDY INDUSTRIAL ESTATE,GUINDY.CHENNAI	veepeesindia@gmail.com	044-43534354
		14676	ITW INDIA LIMITED: WELDING GROUP.	CORPORATE HOUSE,NO.1, SUN CHAMBERS,NEAR SOLA BRIDGE, S.G. HIGHWAY,AHMEDABAD.	fredric.prabhu@itwindia.com	079 3315 4009
WCF02	WELDG.WIRE:FLUX CORE	20047	KANEMATSU TRADING CORPORATION	6th FLOOR,AKEBONO NIHONBASHI BLDG,19 - 5,NIHONBASHIKOAMI-CHO,CHUO - KU, TOKYO, 103 - 0016.	nikko-bocki@kgt.kanematsu.co.jp	81 3 5283 3680
		20563	BOHLER SCHWEISSTECHNNIK	UNIONSTRASSE-1,D-59067 HAMM,DEUTSCHLAND GmbH.,GERMANY		
WCF03	WG:WIRE.FC.E309LMoTO	20563	BOHLER SCHWEISSTECHNNIK	UNIONSTRASSE-1,D-59067 HAMM,DEUTSCHLAND GmbH.,GERMANY		
		20047	KANEMATSU TRADING CORPORATION	6th FLOOR,AKEBONO NIHONBASHI BLDG,19 - 5,NIHONBASHIKOAMI-CHO,CHUO - KU, TOKYO, 103 - 0016.	nikko-bocki@kgt.kanematsu.co.jp	81 3 5283 3680
		20033	KISWEL LTD.,	HEUNGKOOK B/D, 43-1,JUJA-DONGCHUNG-GU, C.P.O.BOX 8641SEOUL, KOREA.SEOUL,KOREA.	export@kiswel.com	82-2-2270-9400
WCF04	WELDG: WIRE: FLUX CO	91270	VEEPEES INDIA,	C-52, 4TH AVENUE ROAD,GUINDY INDUSTRIAL ESTATE,GUINDY.CHENNAI	veepeesindia@gmail.com	044-43534354
		21065	HYUNDAI WELDING CO. LTD.,	15F, 137-37 GANGNAM KU,INSONG BUILDING,SAMSUNG DONG,SEOUL	alex@hdweld.co.kr	82-02 6230-6077

**SECTION - VIII
LIST OF APPROVED VENDORS**

1) WELDING CONSUMABLES SUPPLIERS LIST

Mat Group	Material Group Description	Vendor No	Vendor Name	Vendor Address	EMAIL	PHONE1
		20047	KANEMATSU TRADING CORPORATION	6th FLOOR,AKEBONO NIHONBASHI BLDG,19 - 5,NIHONBASHIKOAMI-CHO,CHUO - KU, TOKYO, 103 - 0016.	nikko-bocki@kgt.kanematsu.co.jp	81 3 5283 3680
WCF05	WELDG: WIRE: FLUX CO	91270	VEEPEES INDIA,	C-52, 4TH AVENUE ROAD,GUINDY INDUSTRIAL ESTATE,GUINDY.CHENNAI	veepeesindia@gmail.com	044-43534354
		20047	KANEMATSU TRADING CORPORATION	6th FLOOR,AKEBONO NIHONBASHI BLDG,19 - 5,NIHONBASHIKOAMI-CHO,CHUO - KU, TOKYO, 103 - 0016.	nikko-bocki@kgt.kanematsu.co.jp	81 3 5283 3680
WCF06	WELDG. WIRE: FLUX CO	91270	VEEPEES INDIA,	C-52, 4TH AVENUE ROAD,GUINDY INDUSTRIAL ESTATE,GUINDY.CHENNAI	veepeesindia@gmail.com	044-43534354
		20047	KANEMATSU TRADING CORPORATION	6th FLOOR,AKEBONO NIHONBASHI BLDG,19 - 5,NIHONBASHIKOAMI-CHO,CHUO - KU, TOKYO, 103 - 0016.	nikko-bocki@kgt.kanematsu.co.jp	81 3 5283 3680
		20011	BOHLER SCHWEISSTECHNIK AUSTRIA	WERK DEUCHENDORF,A 8605, KAPPENBERG, POSTFACH - 9,AUSTRIA.AUSTRIA.		0043/3862301
		20067	UTP SCHWEISS MATERIAL GMBH & CO	ELSASSER STR 10D-79189, BAD KROZINGENGERMANY.		49(0) 07633 / 40
WCF09	E71T-1 MARATHON PACK	20047	KANEMATSU TRADING CORPORATION	6th FLOOR,AKEBONO NIHONBASHI BLDG,19 - 5,NIHONBASHIKOAMI-CHO,CHUO - KU, TOKYO, 103 - 0016.	nikko-bocki@kgt.kanematsu.co.jp	81 3 5283 3680
		91270	VEEPEES INDIA,	C-52, 4TH AVENUE ROAD,GUINDY INDUSTRIAL ESTATE,GUINDY.CHENNAI	veepeesindia@gmail.com	044-43534354
		20970	THE SHANGHAI LINCOLN ELECTRIC	LANE 5008,HU TAI ROAD,BOASHAN, SHANGAI-201907		86 21 560 26664
		14676	ITW INDIA LIMITED: WELDING GROUP.	CORPORATE HOUSE,NO.1, SUN CHAMBERS,NEAR SOLA BRIDGE, S.G. HIGHWAY,AHMEDABAD.	fredric.prabhu@itwindia.com	079 3315 4009
		10081	ESAB INDIA LTD	KARUMUTTU CENTRE, 6TH FLOORNEW NO.634(OLD NO.498)ANNA SALAI, NANDANAM,CHENNAI-35CHENNAI	jagdeesh.ds@esab.co.in	044-826 9343
		21065	HYUNDAI WELDING CO. LTD.,	15F, 137-37 GANGNAM KU,INSONG BUILDING,SAMSUNG DONG,SEOUL	alex@hdweld.co.kr	82-02 6230-6077
WCF11	ER70S - 6 BULK PACKS	20970	THE SHANGHAI LINCOLN ELECTRIC	LANE 5008,HU TAI ROAD,BOASHAN, SHANGAI-201907		86 21 560 26664
		14676	ITW INDIA LIMITED: WELDING GROUP.	CORPORATE HOUSE,NO.1, SUN CHAMBERS,NEAR SOLA BRIDGE, S.G. HIGHWAY,AHMEDABAD.	fredric.prabhu@itwindia.com	079 3315 4009

**SECTION - VIII
LIST OF APPROVED VENDORS**

1) WELDING CONSUMABLES SUPPLIERS LIST

Mat Group	Material Group Description	Vendor No	Vendor Name	Vendor Address	EMAIL	PHONE1
		10081	ESAB INDIA LTD	KARUMUTTU CENTRE, 6TH FLOORNEW NO.634(OLD NO.498)ANNA SALAI, NANDANAM,CHENNAI-35CHENNAI	jagdeesh.ds@esab.co.in	044-826 9343
WCFA1	BULKPACK :E551T1-B2C	14676	ITW INDIA LIMITED: WELDING GROUP.	CORPORATE HOUSE,NO.1, SUN CHAMBERS,NEAR SOLA BRIDGE, S.G. HIGHWAY,AHMEDABAD.	fredric.prabhu@itwindia.com	079 3315 4009
		91270	VEEPEES INDIA,	C-52, 4TH AVENUE ROAD,GUINDY INDUSTRIAL ESTATE,GUINDY.CHENNAI	veepeesindia@gmail.com	044-43534354
WCH03	WELD:SMAW:HF-ECrA	20130	ALCONIX CORPORATION	SANNO PARK TOWER,12TH FLOOR,2-11-1 NAGATA-CHO,CHIYODA-KU,TOKYO ,JAPAN	Inamori.khei@alconix.com	
		20018	KENNAMETAL STELLITE	L.P. 1201 Eisenhower Drive N.Goshen ,IN 46526 USAUSA	asiasales@stellitesales.com	44-0-1793 498...
WCH05	SMAW ELECTRO ECoCr-E	20073	WEARTECH INTL INC	13032, PARK STREETSANTA FE SPRINGS , CA 90670USAUSA		001-562 945 7847
WCL07	WELDG.ELECTRODES:SMA	10774	D&H SECHERON ELECTRODES PVT LTD.	P.B.NO.344-46,INDL.ESTATE,KILAMAIDANINDORE	sales@dnhsecheron.net	0731-4229222
		20067	UTP SCHWEISS MATERIAL GMBH & CO	ELSASSER STR 10D-79189, BAD KROZINGENGERMANY.		49(0) 07633 / 40
		21991	SPECIAL METALS WELDING PRODUCTS	1401,BURRIS ROAD,NEWTON,NORTH COROLINA 28658	rphillips@smwpc.com	828-465-0352
		20563	BOHLER SCHWEISSTECHNNIK	UNIONSTRASSE-1,D-59067 HAMM,DEUTSCHLAND GmbH.,GERMANY		
WCL08	SMAW ELECTRODE	21411	METRODE PRODUCTS LIMITED,	HANWORTH LANE,CHERTESY,SURREY KT169LL,		
		21991	SPECIAL METALS WELDING PRODUCTS	1401,BURRIS ROAD,NEWTON,NORTH COROLINA 28658	rphillips@smwpc.com	828-465-0352
		22391	AIR-LIQUIDE WELDING FRANCE,	13,RUE D'EPLUCHES-BP70024 SAINT-OUEN I'AUMONE,95315 CERGY PONTOISE CEDEX	jean-paul.shmitt@airliquide.com	1342 13480
WCS20	WELDG.ELECTRODES:SMA	10774	D&H SECHERON ELECTRODES PVT LTD.	P.B.NO.344-46,INDL.ESTATE,KILAMAIDANINDORE	sales@dnhsecheron.net	0731-4229222
		10081	ESAB INDIA LTD	KARUMUTTU CENTRE, 6TH FLOORNEW NO.634(OLD NO.498)ANNA SALAI, NANDANAM,CHENNAI-35CHENNAI	jagdeesh.ds@esab.co.in	044-826 9343
		11420	MODI ARC ELECTRODES CO.	MODINAGARUTTAR PRADESHGHAZIABAD	modiarc@ndb.vsnl.net.in	01232 - 242427
		11378	MAILAM INDIA LIMITED	MAILAM MAIN ROAD,SEDARAPET,PONDICHERRY	mailam@mailanindia.com	0413-2677311
WCS22	WELDG.ELECTRODES:SMA	10081	ESAB INDIA LTD	KARUMUTTU CENTRE, 6TH FLOORNEW NO.634(OLD NO.498)ANNA SALAI, NANDANAM,CHENNAI-35CHENNAI	jagdeesh.ds@esab.co.in	044-826 9343

**SECTION - VIII
LIST OF APPROVED VENDORS**

1) WELDING CONSUMABLES SUPPLIERS LIST

Mat Group	Material Group Description	Vendor No	Vendor Name	Vendor Address	EMAIL	PHONE1
		10774	D&H SECHERON ELECTRODES PVT LTD.	P.B.NO.344-46,INDL.ESTATE,KILAMAIDANINDORE	sales@dnhsecheron.net	0731-4229222
WCS27	WELDG.ELECTRODES:SMA	10081	ESAB INDIA LTD	KARUMUTTU CENTRE, 6TH FLOORNEW NO.634(OLD NO.498)ANNA SALAI, NANDANAM,CHENNAI-35CHENNAI	jagdeesh.ds@esab.co.in	044-826 9343
		10774	D&H SECHERON ELECTRODES PVT LTD.	P.B.NO.344-46,INDL.ESTATE,KILAMAIDANINDORE	sales@dnhsecheron.net	0731-4229222
WCS28	WELDG.ELECTRODES:SMA	10036	BHARAT HEAVY ELECTRICALS LTD	WELDING CONSUMABLE MFG CENTRETIRUCHIRAPALLITIRUCHIRAPALLI		
		10774	D&H SECHERON ELECTRODES PVT LTD.	P.B.NO.344-46,INDL.ESTATE,KILAMAIDANINDORE	sales@dnhsecheron.net	0731-4229222
		10081	ESAB INDIA LTD	KARUMUTTU CENTRE, 6TH FLOORNEW NO.634(OLD NO.498)ANNA SALAI, NANDANAM,CHENNAI-35CHENNAI	jagdeesh.ds@esab.co.in	044-826 9343
WCS29	WELDG.ELECTRODES:SMA	10081	ESAB INDIA LTD	KARUMUTTU CENTRE, 6TH FLOORNEW NO.634(OLD NO.498)ANNA SALAI, NANDANAM,CHENNAI-35CHENNAI	jagdeesh.ds@esab.co.in	044-826 9343
		10774	D&H SECHERON ELECTRODES PVT LTD.	P.B.NO.344-46,INDL.ESTATE,KILAMAIDANINDORE	sales@dnhsecheron.net	0731-4229222
		10036	BHARAT HEAVY ELECTRICALS LTD	WELDING CONSUMABLE MFG CENTRETIRUCHIRAPALLITIRUCHIRAPALLI		
WCS30	WELDG.ELECTRODES:SMA	11378	MAILAM INDIA LIMITED	MAILAM MAIN ROAD,SEDARAPET,PONDICHERRY	mailam@mailanindia.com	0413-2677311
		10774	D&H SECHERON ELECTRODES PVT LTD.	P.B.NO.344-46,INDL.ESTATE,KILAMAIDANINDORE	sales@dnhsecheron.net	0731-4229222
		10081	ESAB INDIA LTD	KARUMUTTU CENTRE, 6TH FLOORNEW NO.634(OLD NO.498)ANNA SALAI, NANDANAM,CHENNAI-35CHENNAI	jagdeesh.ds@esab.co.in	044-826 9343
		11420	MODI ARC ELECTRODES CO.	MODINAGARUTTAR PRADESHGHAZIABAD	modiarc@ndb.vsnl.net.in	01232 - 242427
WCS31	WELD:SMAW:SS E410-15	10774	D&H SECHERON ELECTRODES PVT LTD.	P.B.NO.344-46,INDL.ESTATE,KILAMAIDANINDORE	sales@dnhsecheron.net	0731-4229222
		10036	BHARAT HEAVY ELECTRICALS LTD	WELDING CONSUMABLE MFG CENTRETIRUCHIRAPALLITIRUCHIRAPALLI		
		11378	MAILAM INDIA LIMITED	MAILAM MAIN ROAD,SEDARAPET,PONDICHERRY	mailam@mailanindia.com	0413-2677311
WCS32	WELD:SMAW:SS E430-15	10774	D&H SECHERON ELECTRODES PVT LTD.	P.B.NO.344-46,INDL.ESTATE,KILAMAIDANINDORE	sales@dnhsecheron.net	0731-4229222
		11378	MAILAM INDIA LIMITED	MAILAM MAIN ROAD,SEDARAPET,PONDICHERRY	mailam@mailanindia.com	0413-2677311

**SECTION - VIII
LIST OF APPROVED VENDORS**

1) WELDING CONSUMABLES SUPPLIERS LIST

Mat Group	Material Group Description	Vendor No	Vendor Name	Vendor Address	EMAIL	PHONE1
		10036	BHARAT HEAVY ELECTRICALS LTD	WELDING CONSUMABLE MFG CENTRETIRUCHIRAPALLITIRUCHIRAPALLI		
WCS38	SMAW ELECTRD 253MA	22515	BOHLER WELDING GROUP NORDIC SALES A	BOX 501, SE - 774 27 AVESTA,SWEDEN.	INFO@BWGNORDIC.COM	46022685750
		22516	AB SANDVIK PROCESS SYSTEM,	SE 811 81 SANDVIKENSWEDEEN.	donald.anderson@sandvik.com	4602626 5600
WCS39	SMAW ELEC E308H-16	10081	ESAB INDIA LTD	KARUMUTTU CENTRE, 6TH FLOORNEW NO.634(OLD NO.498)ANNA SALAI, NANDANAM,CHENNAI-35CHENNAI	jagdeesh.ds@esab.co.in	044-826 9343
		10774	D&H SECHERON ELECTRODES PVT LTD.	P.B.NO.344-46,INDL.ESTATE,KILAMAIDANINDORE	sales@dnhsecheron.net	0731-4229222
WCS40	SMAW ELEC E316H-16	10081	ESAB INDIA LTD	KARUMUTTU CENTRE, 6TH FLOORNEW NO.634(OLD NO.498)ANNA SALAI, NANDANAM,CHENNAI-35CHENNAI	jagdeesh.ds@esab.co.in	044-826 9343
		10774	D&H SECHERON ELECTRODES PVT LTD.	P.B.NO.344-46,INDL.ESTATE,KILAMAIDANINDORE	sales@dnhsecheron.net	0731-4229222
WCT01	WELD:HF-HAY.ALLY 25	20130	ALCONIX CORPORATION	SANNO PARK TOWER,12TH FLOOR,2-11-1 NAGATA- CHO,CHIYODA-KU,TOKYO ,JAPAN	Inamori.khei@alconix.com	
		10313	ZIRCAST LTD	UNIT -2, NO.37,JIGANI INDUSTRIAL AREABANGALORE - 562 106BANGALORE	jsuresh@zircast.com	08110 /26238
WCT02	WELD:HF-HAY.ALLY 21	20073	WEARTECH INTL INC	13032, PARK STREETSANTA FE SPRINGS , CA 90670USAUSA		001-562 945 7847
		20130	ALCONIX CORPORATION	SANNO PARK TOWER,12TH FLOOR,2-11-1 NAGATA- CHO,CHIYODA-KU,TOKYO ,JAPAN	Inamori.khei@alconix.com	
WCT03	WELD:HF-RCO CRA	20018	KENNAMETAL STELLITE	L.P. 1201 Eisenhower Drive N.Goshen ,IN 46526 USAUSA	asiasales@stellitesales.com	44-0-1793 498...
		20073	WEARTECH INTL INC	13032, PARK STREETSANTA FE SPRINGS , CA 90670USAUSA		001-562 945 7847
		20130	ALCONIX CORPORATION	SANNO PARK TOWER,12TH FLOOR,2-11-1 NAGATA- CHO,CHIYODA-KU,TOKYO ,JAPAN	Inamori.khei@alconix.com	
		10313	ZIRCAST LTD	UNIT -2, NO.37,JIGANI INDUSTRIAL AREABANGALORE - 562 106BANGALORE	jsuresh@zircast.com	08110 /26238
WCT04	WG:PWD:HF:TYP COCRA	20011	BOHLER SCHWEISSTECHNIK AUSTRIA	WERK DEUCHENDORF,A 8605, KAPPENBERG, POSTFACH - 9,AUSTRIA.AUSTRIA.		0043/3862301
		20073	WEARTECH INTL INC	13032, PARK STREETSANTA FE SPRINGS , CA 90670USAUSA		001-562 945 7847
		20018	KENNAMETAL STELLITE	L.P. 1201 Eisenhower Drive N.Goshen ,IN 46526 USAUSA	asiasales@stellitesales.com	44-0-1793 498...
		20067	UTP SCHWEISS MATERIAL GMBH & CO	ELSASSER STR 10D-79189, BAD KROZINGENGERMANY.		49(0) 07633 / 40

**SECTION - VIII
LIST OF APPROVED VENDORS**

1) WELDING CONSUMABLES SUPPLIERS LIST

Mat Group	Material Group Description	Vendor No	Vendor Name	Vendor Address	EMAIL	PHONE1
		20130	ALCONIX CORPORATION	SANNO PARK TOWER,12TH FLOOR,2-11-1 NAGATA-CHO,CHIYODA-KU,TOKYO ,JAPAN	Inamori.khei@alconix.com	
		20321	HOGANAS BELGIUM SA	COLDSTREAM DIVISIONRUELLE GROS PIERRE 10B-7800 ATHRUELLE GROS PIERRE 10B-7800 ATH		
WCW01	EL-8 SAW WIRE	14791	ANAND ARC LTD.,	NO.22(OLD.31),RAILWAY COLONY,III STREET,AMINJIKARAI,CHENNAI		044 23746379
		15085	VOLTARC ELECTRODES (P) LTD,	10-77, FIRST MAIN,ROYAL NAGAR,H.O.SURYAJYOTHI,R.C.ROAD, P.B.NO.33,TIRUPATHI	voltarc@rediffmail.com	0877 2241462
		15084	DWEKAM ELECTRODES LTD,	TALAWALI CHANDA,A.B.ROAD, P.O.MANGILAINDORE (MP)	vk.khandelwal@dwekam.org	0731 422 9500...
		13693	RASI ELECTRODES LTD.,	21, RAJA ANNAMALAI ROAD,FLAT NO A / 14, THIRD FLOOR,CHENNAI	rele@airtelmail.in	044 26424523
		19905	T.M.INDUSTRIES,	PLOT NO.26-27,PHASE-I,SILTARA GROWTH CENTRE,SILTARA RAIPUR	tmtapadia@rediffmail.com	0771-2100524
		10774	D&H SECHERON ELECTRODES PVT LTD.	P.B.NO.344-46,INDL.ESTATE,KILAMAIDANINDORE	sales@dnhsecheron.net	0731-4229222
		19114	WELMET TECHNOLOGIES PVT. LTD.,	34,P.N.MAIDU INDUSTRIAL ESTATE,M.I.D.C. HINGNA,NAGPUR		
		11528	RAAJRATNA ELECTRODES LTD	11, SONAROOPA, OPP.LALBANGLOWC.G.ROAD, NAVARANGPURA AHMEDABAD	mktg@gnaht-rel.global.net.in	079 - 6445258
		13534	RUPA INDUSTRIES,	2-2-105 to 180/10,GANESH CHAMBERSRANIGUNJ,SECUNDERABAD	rupaent@vsnl.net	040-2771 3714
		13211	D&H INDIA LIMITED	PLOT 'A', SECTOR 'A'INDUSTRIAL AREA,SANWER ROADINDORE	dhindia@sancharnet.in	0731-4273501-...
		11378	MAILAM INDIA LIMITED	MAILAM MAIN ROAD,SEDARAPET,PONDICHERRY	mailam@mailanindia.com	0413-2677311
		17813	K.M.CROWN WELDING CONSUMABLES PVT.,	BLOCK NO.16A,16B & 17A,INDUSTRIAL AREA NO.1,A.B.ROAD,DEWAS	kmcrownwelding@dataone.com	07272 259384578
		16166	EVERSHINE WIRES	178/2-A3, THURAIYUR ROAD,PULIVALAM,MUSIRI TALUK,TRICHY	evershinewires@rediffmail.com	04327 235527
		10785	ADOR WELDING LIMITED	CORPORATE MARKETING OFFICE,P.B. NO. 2, CHINCHWAD,PUNE	acegasindia@gamil.com	
		10081	ESAB INDIA LTD	KARUMUTTU CENTRE, 6TH FLOORNEW NO.634(OLD NO.498)ANNA SALAI, NANDANAM,CHENNAI-35CHENNAI	jagdeesh.ds@esab.co.in	044-826 9343
11288	JAGSHAAN INDUSTRIES	94 FRIENDS COLONYKATOL ROADNAGPUR	jagshaan@nagpur.dot.net.in	0712 - 581557		

**SECTION - VIII
LIST OF APPROVED VENDORS**

1) WELDING CONSUMABLES SUPPLIERS LIST

Mat Group	Material Group Description	Vendor No	Vendor Name	Vendor Address	EMAIL	PHONE1
		15100	MANTEK WIRES	24,SIDCO INDUSTRIAL ESTATE,P.VADUGAPALAYAM,PALLADAMCOIMBAT ORE		
		14340	NALLI ARC INDUSTRIE,	SF NO. 340,NALLIPALAYAM,PADIYUR POST,KANGAYAM TALUKERODE Dt.	nalliar@yahoo.com	04257 245185
		15101	PRECISION WELDARC LTD,	49,B.T. ROAD, PANIHATI24,PARGANAS (NORTH)KOLKATA.	pwires@yahoo.co.in	033 25634753
		14455	WIRE AND WIRE PRODUCTS	SIDCO INDUSTRIAL ESTATEAMBATTURCHENNAI	wwp@vsnl.net	044 26242378
		15810	NOUVEAUX INDUSTRIES (P) LTD.,	NO.2,SOWDAMBIGA NAGARTIRUPUR ROAD.KANGAYAM		
WCW02	WELDING WIRE:SAW EB3	20047	KANEMATSU TRADING CORPORATION	6th FLOOR,AKEBONO NIHONBASHI BLDG,19 - 5,NIHONBASHIKOAMI-CHO,CHUO - KU, TOKYO, 103 - 0016.	nikko-bocki@kgt.kanematsu.co.jp	81 3 5283 3680
		20563	BOHLER SCHWEISSTECHNIK	UNIONSTRASSE-1,D-59067 HAMM,DEUTSCHLAND GmbH.,GERMANY		
		20011	BOHLER SCHWEISSTECHNIK AUSTRIA	WERK DEUCHENDORF,A 8605, KAPPENBERG, POSTFACH - 9,AUSTRIA.AUSTRIA.		0043/3862301
WCW04	WG:WIRE:SAW ER430	20047	KANEMATSU TRADING CORPORATION	6th FLOOR,AKEBONO NIHONBASHI BLDG,19 - 5,NIHONBASHIKOAMI-CHO,CHUO - KU, TOKYO, 103 - 0016.	nikko-bocki@kgt.kanematsu.co.jp	81 3 5283 3680
		20033	KISWEL LTD.,	HEUNGKOOK B/D, 43-1,JUJA-DONGCHUNG-GU, C.P.O.BOX 8641SEOUL, KOREA.SEOUL,KOREA.	export@kiswel.com	82-2-2270-9400
WCW05	WG:WIRE:SAW ER410	20047	KANEMATSU TRADING CORPORATION	6th FLOOR,AKEBONO NIHONBASHI BLDG,19 - 5,NIHONBASHIKOAMI-CHO,CHUO - KU, TOKYO, 103 - 0016.	nikko-bocki@kgt.kanematsu.co.jp	81 3 5283 3680
		20033	KISWEL LTD.,	HEUNGKOOK B/D, 43-1,JUJA-DONGCHUNG-GU, C.P.O.BOX 8641SEOUL, KOREA.SEOUL,KOREA.	export@kiswel.com	82-2-2270-9400
WCW06	WELDING WIRE:SAW EB2	20047	KANEMATSU TRADING CORPORATION	6th FLOOR,AKEBONO NIHONBASHI BLDG,19 - 5,NIHONBASHIKOAMI-CHO,CHUO - KU, TOKYO, 103 - 0016.	nikko-bocki@kgt.kanematsu.co.jp	81 3 5283 3680
		20563	BOHLER SCHWEISSTECHNIK	UNIONSTRASSE-1,D-59067 HAMM,DEUTSCHLAND GmbH.,GERMANY		
		20011	BOHLER SCHWEISSTECHNIK AUSTRIA	WERK DEUCHENDORF,A 8605, KAPPENBERG, POSTFACH - 9,AUSTRIA.AUSTRIA.		0043/3862301

**SECTION - VIII
LIST OF APPROVED VENDORS**

1) WELDING CONSUMABLES SUPPLIERS LIST

Mat Group	Material Group Description	Vendor No	Vendor Name	Vendor Address	EMAIL	PHONE1
WCW08	WELDING WIRE:SAW EA4	20047	KANEMATSU TRADING CORPORATION	6th FLOOR,AKEBONO NIHONBASHI BLDG,19 - 5,NIHONBASHIKOAMI-CHO,CHUO - KU, TOKYO, 103 - 0016.	nikko-bocki@kgt.kanematsu.co.jp	81 3 5283 3680
		20011	BOHLER SCHWEISSTECHNIK AUSTRIA	WERK DEUCHENDORF,A 8605, KAPPENBERG, POSTFACH - 9,AUSTRIA.AUSTRIA.		0043/3862301
		20563	BOHLER SCHWEISSTECHNNIK	UNIONSTRASSE-1,D-59067 HAMM,DEUTSCHLAND GmbH.,GERMANY		
WCW09	WELDING WIRE:SAW EM1	20047	KANEMATSU TRADING CORPORATION	6th FLOOR,AKEBONO NIHONBASHI BLDG,19 - 5,NIHONBASHIKOAMI-CHO,CHUO - KU, TOKYO, 103 - 0016.	nikko-bocki@kgt.kanematsu.co.jp	81 3 5283 3680
		15810	NOUVEAUX INDUSTRIES (P) LTD.,	NO.2,SOWDAMBIGA NAGARTIRUPUR ROAD.KANGAYAM		
		10081	ESAB INDIA LTD	KARUMUTTU CENTRE, 6TH FLOORNEW NO.634(OLD NO.498)ANNA SALAI, NANDANAM,CHENNAI-35CHENNAI	jagdeesh.ds@esab.co.in	044-826 9343
		20563	BOHLER SCHWEISSTECHNNIK	UNIONSTRASSE-1,D-59067 HAMM,DEUTSCHLAND GmbH.,GERMANY		
WCW12	WELDING WIRE:SAW 3 B	20011	BOHLER SCHWEISSTECHNIK AUSTRIA	WERK DEUCHENDORF,A 8605, KAPPENBERG, POSTFACH - 9,AUSTRIA.AUSTRIA.		0043/3862301
		20563	BOHLER SCHWEISSTECHNNIK	UNIONSTRASSE-1,D-59067 HAMM,DEUTSCHLAND GmbH.,GERMANY		
		20047	KANEMATSU TRADING CORPORATION	6th FLOOR,AKEBONO NIHONBASHI BLDG,19 - 5,NIHONBASHIKOAMI-CHO,CHUO - KU, TOKYO, 103 - 0016.	nikko-bocki@kgt.kanematsu.co.jp	81 3 5283 3680
		10081	ESAB INDIA LTD	KARUMUTTU CENTRE, 6TH FLOORNEW NO.634(OLD NO.498)ANNA SALAI, NANDANAM,CHENNAI-35CHENNAI	jagdeesh.ds@esab.co.in	044-826 9343
		22391	AIR-LIQUIDE WELDING FRANCE,	13,RUE D'EPLUCHES-BP70024 SAINT-OUEN I'AUMONE,95315 CERGY PONTOISE CEDEX	jean-paul.shmitt@airliquide.com	1342 13480
		21411	METRODE PRODUCTS LIMITED,	HANWORTH LANE,CHERTESY,SURREY KT169LL,		

BHEL:BAP:Ranipet :: Outsourcing Department

Section-VIII - 2) List of approved vendors for procurement of Paints

SL-No.	Prod Description	SL-No	Supplier Name M/s.	Place
01	INTUMESCENT PAINT	01	AKZO NOBEL INDIA LIMITED	BENGALURU
	INTUMESCENT PAINT	02	CLEAN COATS PVT. LTD.	MUMBAI
	INTUMESCENT PAINT	03	NOBLE PAINTS PVT. LTD	MUMBAI
02	CHLORINATED RUBBER PAINTS	01	ASIAN PAINTS LTD	MUMBAI
	CHLORINATED RUBBER PAINTS	02	ASIAN PAINTS LTD	CHENNAI
	CHLORINATED RUBBER PAINTS	03	BERGER PAINTS INDIA LTD	KOLKATA
	CHLORINATED RUBBER PAINTS	04	BERGER PAINTS INDIA LIMITED	CHENNAI
	CHLORINATED RUBBER PAINTS	05	CARBOLINE INDIA PVT. LTD.,	CHENNAI
	CHLORINATED RUBBER PAINTS	06	JENSON & NICHOLSON LTD.,	KOLKATA
	CHLORINATED RUBBER PAINTS	07	SHALIMAR PAINTS	KOLKATA
	CHLORINATED RUBBER PAINTS	08	SHALIMAR PAINTS	CHENNAI
03	HEAT RESISTANT EPOXY PAINTS	01	ASIAN PAINTS LTD	MUMBAI
	HEAT RESISTANT EPOXY PAINTS	02	ASIAN PAINTS LTD	CHENNAI
	HEAT RESISTANT EPOXY PAINTS	03	BERGER PAINTS INDIA LTD	KOLKATA
	HEAT RESISTANT EPOXY PAINTS	04	BERGER PAINTS INDIA LIMITED	CHENNAI
	HEAT RESISTANT EPOXY PAINTS	05	CARBOLINE INDIA PVT. LTD.,	CHENNAI
	HEAT RESISTANT EPOXY PAINTS	06	JENSON & NICHOLSON LTD.,	KOLKATA
	HEAT RESISTANT EPOXY PAINTS	07	SHALIMAR PAINTS	KOLKATA
	HEAT RESISTANT EPOXY PAINTS	08	SHALIMAR PAINTS	CHENNAI
04	POLYURETHANE ACRYLIC PAINTS	01	ASIAN PAINTS LTD	MUMBAI
	POLYURETHANE ACRYLIC PAINTS	02	ASIAN PAINTS LTD	CHENNAI
	POLYURETHANE ACRYLIC PAINTS	03	BERGER PAINTS INDIA LTD	KOLKATA
	POLYURETHANE ACRYLIC PAINTS	04	BERGER PAINTS INDIA LIMITED	CHENNAI
	POLYURETHANE ACRYLIC PAINTS	05	CARBOLINE INDIA PVT. LTD.,	CHENNAI
	POLYURETHANE ACRYLIC PAINTS	06	JENSON & NICHOLSON LTD.,	KOLKATA
	POLYURETHANE ACRYLIC PAINTS	07	SHALIMAR PAINTS	KOLKATA
	POLYURETHANE ACRYLIC PAINTS	08	SHALIMAR PAINTS	CHENNAI
05	REDOXIDE ZINC CHROME PRIMER PAINT IS:2074	01	ADDISION PAINTS	CHENNAI
	REDOXIDE ZINC CHROME PRIMER PAINT IS:2074	02	ASIAN PAINTS LTD	MUMBAI
	REDOXIDE ZINC CHROME PRIMER PAINT IS:2074	03	ASIAN PAINTS LTD	CHENNAI
	REDOXIDE ZINC CHROME PRIMER PAINT IS:2074	04	BERGER PAINTS INDIA LTD	KOLKATA
	REDOXIDE ZINC CHROME PRIMER PAINT IS:2074	05	BERGER PAINTS INDIA LIMITED	CHENNAI
	REDOXIDE ZINC CHROME PRIMER PAINT IS:2074	06	BOMBAY PAINTS, CORRIDOR ROAD,	MUMBAI
	REDOXIDE ZINC CHROME PRIMER PAINT IS:2074	07	JENSON & NICHOLSON LTD.,	KOLKATA

SL-No.	Prod Description	SL-No	Supplier Name M/s.	Place
	REDOXIDE ZINC CHROME PRIMER PAINT IS:2074	08	NOBLE PAINT & VARNISH CO P LTD	CHENNAI
	REDOXIDE ZINC CHROME PRIMER PAINT IS:2074	09	PERIYAR CNSL WORKERS INDL.COOP	KUNDRAKUDI
06	RUST PREVENTIVE OIL	01	PLASTIPEEL CHEMICALS & PLASTIC	THANE
	RUST PREVENTIVE OIL	02	PROCESS AIDS	BENGALURU
	RUST PREVENTIVE OIL	03	SEMPER-SEAL CHEMICALS,	AGRA
	RUST PREVENTIVE OIL	04	THIN CHEMIE FORMULATIONS	CHENNAI
	RUST PREVENTIVE OIL	05	WESTERN (I) PAINT & COLOUR CO,	CHENNAI
07	SPECIAL PAINTS OF ALL TYPES	01	ASIAN PAINTS LTD	MUMBAI
	SPECIAL PAINTS OF ALL TYPES	02	ASIAN PAINTS LTD	CHENNAI
	SPECIAL PAINTS OF ALL TYPES	03	BERGER PAINTS INDIA LTD	KOLKATA
	SPECIAL PAINTS OF ALL TYPES	04	BERGER PAINTS INDIA LIMITED	CHENNAI
	SPECIAL PAINTS OF ALL TYPES	05	CARBOLINE INDIA PVT. LTD.,	CHENNAI
	SPECIAL PAINTS OF ALL TYPES	06	FOSROC CHEMICALS (I) LTD	BENGALURU
	SPECIAL PAINTS OF ALL TYPES	07	FOSROC CHEMICALS (INDIA) LTD	CHENNAI
	SPECIAL PAINTS OF ALL TYPES	08	JENSON & NICHOLSON LTD.,	KOLKATA
	SPECIAL PAINTS OF ALL TYPES	09	SHALIMAR PAINTS	KOLKATA
	SPECIAL PAINTS OF ALL TYPES	010	SHALIMAR PAINTS	CHENNAI
08	EPOXY BASED & FINISH PAINTS &ITS THINER	01	ASIAN PAINTS LTD	CHENNAI
	EPOXY BASED & FINISH PAINTS &ITS THINER	02	BERGER PAINTS INDIA LIMITED	CHENNAI
	EPOXY BASED & FINISH PAINTS &ITS THINER	03	GRAUER&WEIL(INDIA) LIMITED,	CHENNAI
	EPOXY BASED & FINISH PAINTS &ITS THINER	04	SHALIMAR PAINTS	CHENNAI
	EPOXY BASED & FINISH PAINTS &ITS THINER	05	AKZO NOBEL INDIA LIMITED	BENGALURU
	EPOXY BASED & FINISH PAINTS &ITS THINER	06	GRAND POLYCOATS CO.PVT LTD	VADODARA
09	SPECIAL PRIMER PAINTS AND ITS THINER	01	ASIAN PAINTS LTD	CHENNAI
	SPECIAL PRIMER PAINTS AND ITS THINER	02	BERGER PAINTS INDIA LIMITED	CHENNAI
	SPECIAL PRIMER PAINTS AND ITS THINER	03	GRAUER&WEIL(INDIA) LIMITED,	CHENNAI
	SPECIAL PRIMER PAINTS AND ITS THINER	04	SHALIMAR PAINTS	CHENNAI
	SPECIAL PRIMER PAINTS AND ITS THINER	05	AKZO NOBEL INDIA LIMITED	BENGALURU
	SPECIAL PRIMER PAINTS AND ITS THINER	06	KANSAI NEROLAC PAINTS LIMITED	CHENNAI
	SPECIAL PRIMER PAINTS AND ITS THINER	07	GRAND POLYCOATS CO.PVT LTD	VADODARA
010	CONVENTIONAL PAINTS & THINNER	01	ASIAN PAINTS LTD	CHENNAI
	CONVENTIONAL PAINTS & THINNER	02	BERGER PAINTS INDIA LIMITED	CHENNAI
	CONVENTIONAL PAINTS & THINNER	03	GRAUER&WEIL(INDIA) LIMITED,	CHENNAI
	CONVENTIONAL PAINTS & THINNER	04	CARBOLINE INDIA PVT. LTD.,	CHENNAI
	CONVENTIONAL PAINTS & THINNER	05	SHALIMAR PAINTS	CHENNAI
	CONVENTIONAL PAINTS & THINNER	06	WESTERN (I) PAINT & COLOUR CO,	CHENNAI

SL-No.	Prod Description	SL-No	Supplier Name M/s.	Place
	CONVENTIONAL PAINTS & THINNER	07	NOVAA PAINTS	TIRUCHIRAPPALLI
	CONVENTIONAL PAINTS & THINNER	08	SUNDARAM PAINTS (P) LTD	THANJAVUR
	CONVENTIONAL PAINTS & THINNER	09	KANSAI NEROLAC PAINTS LIMITED	CHENNAI
	CONVENTIONAL PAINTS & THINNER	010	SRI MEENAKSHI PAINT INDUSTRIES,	PUDUKKOTAI
	CONVENTIONAL PAINTS & THINNER	011	PASUM MEENA PAINT INDUSTRIES	SIVAGANGAI DIST
	CONVENTIONAL PAINTS & THINNER	012	JAI KAMAL PAINTS	CHENNAI
	CONVENTIONAL PAINTS & THINNER	013	CHEMECOAT PAINTS	TIRUCHIRAPPALLI
011	SEA WORTHY RUST PREVENTIVE OIL	01	SHALIMAR PAINTS	CHENNAI
	SEA WORTHY RUST PREVENTIVE OIL	02	SUNDARAM PAINTS (P) LTD	THANJAVUR
012	H.R.ALUMINIUM PAINT GRADE II TO IS:13183	01	ASIAN PAINTS LTD	CHENNAI
	H.R.ALUMINIUM PAINT GRADE II TO IS:13183	02	BERGER PAINTS INDIA LIMITED	CHENNAI
	H.R.ALUMINIUM PAINT GRADE II TO IS:13183	03	SHALIMAR PAINTS	CHENNAI
	H.R.ALUMINIUM PAINT GRADE II TO IS:13183	04	KANSAI NEROLAC PAINTS LIMITED	CHENNAI
	H.R.ALUMINIUM PAINT GRADE II TO IS:13183	05	STAR PAINT & OIL INDUSTRIES	MUMBAI
013	CONVENTIONAL PAINTS & THINNER	01	ASIAN PAINTS LTD	CHENNAI
	CONVENTIONAL PAINTS & THINNER	02	BERGER PAINTS INDIA LIMITED	CHENNAI
	CONVENTIONAL PAINTS & THINNER	03	GRAUER&WEIL(INDIA) LIMITED,	CHENNAI
	CONVENTIONAL PAINTS & THINNER	04	CARBOLINE INDIA PVT. LTD.,	CHENNAI
	CONVENTIONAL PAINTS & THINNER	05	SHALIMAR PAINTS	CHENNAI
	CONVENTIONAL PAINTS & THINNER	06	WESTERN (I) PAINT & COLOUR CO,	CHENNAI
	CONVENTIONAL PAINTS & THINNER	07	NOVAA PAINTS	TIRUCHIRAPPALLI
	CONVENTIONAL PAINTS & THINNER	08	SUNDARAM PAINTS (P) LTD	THANJAVUR
	CONVENTIONAL PAINTS & THINNER	09	KANSAI NEROLAC PAINTS LIMITED	CHENNAI
	CONVENTIONAL PAINTS & THINNER	010	SRI MEENAKSHI PAINT INDUSTRIES,	PUDUKKOTAI
	CONVENTIONAL PAINTS & THINNER	011	PASUM MEENA PAINT INDUSTRIES	SIVAGANGAI DIST
	CONVENTIONAL PAINTS & THINNER	012	JAI KAMAL PAINTS	CHENNAI
	CONVENTIONAL PAINTS & THINNER	013	CHEMECOAT PAINTS	TIRUCHIRAPPALLI

LEGEND :

Supplier Control :

1. Inspection at Supplier's works by BHEL / QC / Inspection agency appointed by BHEL
2. Inspection at Supplier's works by Customer / Third party
3. Inspection as per approved Quality Plan
4. Qualification of Suppliers Operators & Process for execution of the job
5. Sample approval required
6. Periodical Process audit by BHEL
7. Inspection after receipt at BHEL



Section-VIII- 3) PENETRANT TESTING CHEMICALS AND
MAGNETIC TESTING CONSUMABLES

PENETRANT TESTING

**PENETRANT TESTING CHEMICALS
DYE (SOLVENT REMOVABLE, FLUORESCENT, WATER WASHABLE, POST
EMULSIFIER) , DEVELOPER, CLEANER**

Sl.No	Vendor address	Approved by
1.	P-MET HIGH-TECH COMPANY (P) LTD. 1-5/6,INDUSTRIAL ESTATE, GORWA, BARODA (GUJARAT) INDIA-390016 PHONE NO.: 0265-282326/281125 FAX : 0265-2793868 E-MAIL : P-MET@ICENET.NET	TRICHY HYDERABAD RANIPET HARIDWAR
2.	ORIENTAL CHEMICAL WORKS (P) LTD 23 SATTANA NAICKEN STERRET 1ST LOOR,SRIVISHAKANYA NILAYAM, ADJACENT STREET, NATRAJ THEATRE CHENNAI 600 112	TRICHY RANIPET
3.	ITW SIGNODE INDIA LTD 3RD FLOOR,MERCHANT TOWERS, 5,ROAD NO.4,BANJARA HILLS HYDERBAD 500 034 E MAIL : VARDA@TCH.ITWSIGNODE.CO.IN Ph.No: 044 -24723956	TRICHY HYDERABAD RANIPET
4.	ITW SIGNODE INDIA LTD PLOT NO 34-37, IDA , APIIC, PASHAMNYLARAM, PHASE-II, MEDAK INDIA -502307 PHONE NO.: 08455- 26089, 26055 , 26328 FAX : 08455-26336 EMAIL: dst@fps.itwsignode.co.in	TRICHY HYDERABAD RANIPET HARIDWAR
5.	ITW SIGNODE INDIA LTD. 10, COMMUNITY CENTRE, EAST OF KAILASH, NEW DELHI , INDIA -110065 PHONE NO.: 01126424984, 01126424990	TRICHY HYDERABAD RANIPET HARIDWAR
6.	PRADEEP METAL TREATMENT CHEMICALS (P) LTD. PLOT NOS A-488/489, ROAD U, WAGLE INDUSTRIAL ESTATE, THANE ,INDIA -400604 PHONE NO.:022-5598 8781 / 82 , FAX : 022-2582 7460 E-MAIL : pradeepndt@mtnl.net.in	TRICHY HYDERABAD RANIPET HARIDWAR
7.	FERROCHEM, 1,GURUPRASAD KUNU 1122/6 ERANDAWAANA PUNE 411 004	TRICHY HYDERABAD RANIPET



Section-VIII- 3) PENETRANT TESTING CHEMICALS AND
MAGNETIC TESTING CONSUMABLES

8.	FERROCHEM NDT SYSTEMS PVT. LTD 6, PRAGATI INDUSTRIAL COMPLEX, 17/1-B, KOTHRUD, PUNE (MAHARASHTRA) INDIA -411004 PHONE NO.: (020)5465258/5432528/5437339 FAX : 5463038 E-MAIL : ferro@pn2.vsnl.net.in	TRICHY HYDERABAD RANIPET HARIDWAR
9.	ANDHRA SPARES COMPANY SHOP NO: 5-5-80/2, 1ST FLOOR, SRI SRINIVASA COMMERCIAL COMPLEX, RANIGUNJ, SECUNDERABAD- 500 003	HYDERABAD
10.	CHECKMATE CHEMICALS LTD, 13, MODERN INDUSTRIAL ESTATE, ROHTAK ROAD, BAHADUR GARH, HARYANA 124 507	TRICHY HYDERABAD RANIPET
11.	CHECKMATE CHEMICALS PVT. LTD. EC-11, 2ND FLOOR, INDER PURI, NEW DELHI , INDIA , 110012 PHONE NO.: 011-2585889/25835870 FAX : 011-25833160 E-MAIL : dlsharma@vsnl.com	TRICHY HYDERABAD RANIPET HARIDWAR
12.	NDT CHEMICAL PRODUCTS, 5-7-9/6, SANGEETH NAGAR, KUKATPALLY, HYDERABAD-500 072. EMAIL: ndtcp787_hyd@dataone.in WEB: WWW.NDTCPHYD.COM PHONE: 09246530958	HYDERABAD
13.	THE ORIENTAL CHEMICAL WORKS, KOLKATTA 1/1B, GOBINDA AUDDY ROAD, CHETLA, KOLKATA-700 027	HYDERABAD
14.	M /S KRISH MET TECH PVT LTD 10 /1ST FLOOR, ARUNACHALAM ROAD,(OPP.SURRYA HOSPITAL) SALIGRAM,CHENNAI 600 093 EMAIL KRISHMETTECH@ETH.NET PH 23761491, 23764450	TRICHY RANIPET



Section-VIII- 3) PENETRANT TESTING CHEMICALS AND
MAGNETIC TESTING CONSUMABLES

MAGNETIC TESTING CONSUMABLES
DRY POWDER

Sl.No	Vendor address	Approved by
1.	ITW SIGNODE INDIA LTD 3RD FLOOR, MERCHANT TOWERS, 5, ROAD NO.4, BANJARA HILLS HYDERBAD 500 034 E MAIL: varda@tch.itwsignode.co.in 044 -24723956	TRICHY HYDERABAD
2.	FERROCHEM NDT SYSTEMS PVT. LTD 6, PRAGATI INDUSTRIAL COMPLEX, 17/1-B, KOTHRUD, PUNE (MAHARASHTRA) INDIA-411004 PHONE NO.: (020)5465258/5432528/5437339 FAX : 5463038 E-MAIL : ferro@pn2.vsnl.net.in	TRICHY HYDERABAD
3.	EAST COAST ENTERPRISES 33, BRABOURNE ROAD, P.BNO. 2217 GPO CALCUTTA 700 001	TRICHY HYDERABAD
4.	ELECTRO MAGFIELD CONTROLS & SERVICES 561 G.M.T.H ROAD (NEAR TELEPHONE EXCHANGE) AMBATHUR CHENNAI 600 098 EMAIL: emcs@eth.net PH 625 4327, 652 1041	TRICHY HYDERABAD
5.	EAST WEST ENGG. & ELECTRONICS CO 204, ACHARYA COMMERCIAL CENTRE DR. C. G. ROAD, CHEMBUR MUMBAI 400 074	TRICHY HYDERABAD
6.	KIRAN ENTERPRISES PLOT NO 175, PRAGATHINAGAR, OPP. JNTU KUKATPALLY, HYDRABAD 500 072	HYDERABAD
7.	PARADEEP NDT PRODUCTS REGIS. OFFICE: 32 WESTMINSTER, MANIKIKAR MARG, CHUNABHATTI, SION, MUMBAI-400 022 WORKS: SHED NO.3, CHANDRASAKHA ESTATE SURVEY NO.1, AMBEGAON BUORUK TAL.HAVELI DIST. PUNE 411 046 PHONE NO. 020 -24210699	TRICHY HYDERABAD



Section-VIII- 3) PENETRANT TESTING CHEMICALS AND
MAGNETIC TESTING CONSUMABLES

8.	PRADEEP METAL TREATMENT CHEMICALS (P) LTD. PLOT NOS A-488/489, ROAD U, WAGLE INDUSTRIAL ESTATE, THANE ,INDIA-400604 PHONE NO.: 022-5598 8781 / 82, FAX : 022-2582 7460 E-MAIL : pradeepndt@mtnl.net.in	
----	---	--

MPI CHEMICALS (WET)

Sl.No	Vendor address	Approved by
1.	CHECKMATE CHEMICALS PVT. LTD. EC-11, 2ND FLOOR, INDER PURI, NEW DELHI , INDIA -110012 PHONE NO.: 011-2585869/25835870 FAX : 011-25833180 E-MAIL : dbsharma@vsnl.com	TRICHY HYDERABAD BHOPAL HARIDWAR
2.	P-MET HIGH-TECH COMPANY (P) LTD. 1-5/6,INDUSTRIAL ESTATE, GORWA, BARODA (GUJARAT) INDIA -390016 PHONE NO.: 0265-282326/281125,FAX : 0265-2793868 E-MAIL : p-met@icenet.net	TRICHY HYDERABAD BHOPAL HARIDWAR
3.	K ELECTRONICS G11 ,RAJMAHAL, 55-E,M. VASANJI ROAD ANDHERI(EAST) MUMBAI 400 089 PHONE:020-25432528,25437339 FAX:020-25463038 E-MAIL: ferro@pn2.vsnl.net.in	TRICHY HYDERABAD BHOPAL
4.	PRADEEP METAL TREATMENT CHEMICALS (P) LTD. PLOT NOS A-488/489, ROAD U, WAGLE INDUSTRIAL ESTATE, THANE , INDIA, 400604 PHONE NO.: 022-5598 8781 / 82 , FAX : 022-2582 7460 E-MAIL : pradeepndt@mtnl.net.in	TRICHY HYDERABAD BHOPAL HARIDWAR
5.	PRADEEP NDT PRODUCTS PVT. LTD. 32, WESTMINISTER, MANKIKAR MARG, SION, MUMBAI - 400 022 PHONE:022-24073309, 24093118 pradeepndt@vsnl.net vardeji@bol.net.in	TRICHY HYDERABAD BHOPAL



Section-VIII- 3) PENETRANT TESTING CHEMICALS AND
MAGNETIC TESTING CONSUMABLES

6.	ITW SIGNODE INDIA LTD PLOT NO 34-37, IDA , APIIC, PASHAMNYLARAM, PHASE-II MEDAK, INDIA -502307 PHONE NO.: 08455- 26089, 26055 , 26328 ,FAX : 08455- 26336 EMAIL: dst@fps.itwsignode.co.in	TRICHY HYDERABAD BHOPAL HARIDWAR
7.	ITW SIGNODE INDIA LTD 3 RD FLOOR, MERCCHANT TOWERS, 5, ROAD NO 4, BANJARA HILLS, HYDERABAD-500034 PHONE: 040-23353781 E-MAIL: itwindia@hdl.ven.net.in	TRICHY HYDERABAD BHOPAL
8.	ITW SIGNODE INDIA LTD. 10, COMMUNITY CENTRE, EAST OF KAILASH, NEW DELHI, INDIA -110065 PHONE NO.: 01126424984, 01126424990	TRICHY HYDERABAD BHOPAL HARIDWAR
9.	FERROCHEM NDT SYSTEMS PVT. LTD 6, PRAGATI INDUSTRIAL COMPLEX, 17/1-B, KOTHRUD, PUNE (MAHARASHTRA) ,INDIA-411004 PHONE NO.: (020)5465258/5432528/5437339, FAX : 5463038 E-MAIL : ferro@pn2.vsnl.net.in	TRICHY HYDERABAD BHOPAL HARIDWAR

**ARC Main 54A BHEL Ranipet :: Outsourcing Department
LIST OF NDT APPROVED VENDORS**

Sl.No	Name of the Firm and Address	Approved Methods	Valid upto
1	M/s G.B. NDT Engg. Services, E-52,Industrial Estate,Thuvakudi, Tiruchy-620015 Phone:(0431)2501112,2500891 email:gbandt.xrayengg@yahoo.com	RT, UT, MT, PT	31-05-2024
2	M/s C Premier NDE Services, CP-17, Electrical and Electronics Industrial Estate, Thuvakudi, Tiruchy 620015 Phone (0431)2500878 , 9842455733 email:premierndt@yahoo.com, venu.raj_1954@yahoo.com	RT	31-05-2024
3	M/s Super Quality Services, 95,SQS Building, Near Police Station, Palakkarai Main Road, Trichy-620001Phone (0431)2415087,2414218, Fax- 0431-2464218 E-Mail:sqsndt@yahoo.co.in	RT, UT, MT, PT	31-05-2024
4	M/s Metal Care Engg. Services Plot 13,14, B-1 Kether Manor,3rd Cross, North Extension, Thillai nagar,Trichy 620018 Phone(0431) 2762190, 2481593 9942904651 (Selvaraj) mces_try@yahoo.co.in	RT, MT	31-05-2024
5	M/s Scaanray Metallurgical Services, C-12, Industrial Estate,Mogappair (West) Chennai 600 037 Phone: 044-26250651, 23762613 Fax 26358741 e-mail: scaanray@vsnl.com	RT, UT, MT,PT	31-05-2024
6	M/s Industrial Radiographic Inspection Company SP-111, South Avenue, Ambattur Industrial Estate,Chennai 600 058 Phone: 044-26253235,26250790,26255602, Fax-044-26255838 e-mail : info@iricondt.com	RT,UT	31-05-2024
7	M/s Everest Industrial Radiographer, "GREEN LAND", 1/25, Arisipalayam, Coimbatore- 641032 ,Phone:0422-2638148,2638348, Cell:9843011031 (A.Rathinam) email: everestndt@gmail.com	RT	31-05-2024

8	M/s KGB Inspection Services, P-16, Electrical & Electronics Industrial Estate, Thuvakudi, Tiruchirappalli 620015 Phone (0431)2500164, 9842453258 (Kumaran) email:kgbist2002@yahoo.co.in	RT, UT, MT, PT	31-05-2024
9	M/s Supreme Excel NDT Services, II Floor, Vairam Memorial Complex 24-A/B, Jeeva Street, Subramaniapuram, Tiruchirappalli - 620020 Phone:(0431)2333528, 2501241 e-mail:ndtsrvcs2008@yahoo.co.in	RT, UT, MT, PT	31-05-2024
10	M/s.NDE Inspections, 50,Raja Colony, 4th Cross,Collector Office Road, Trichy-620001. Phone (0431)2416388 , 9345499916 e-mail:ndeinspections@gmail.com, www.rla-ndeinspections.com	RT,UT, MT,PT	31-05-2024
11	M/s Sri Vinayaga NDT Inspection Services, SF 303, Peria Thottam, Kadathur Road, Coimbatore- 641 107. Phone 0422-2653640, 9443027274(Shanmugam) email:svndt@yahoo.co.in	RT	31-05-2022
12	M/s.Sri Shanmuka NDT & Inspection Services, 701, Avoor Road, Mathur, Pudukottai Dist- 622515. email:shanmukandt@gmail.com Mobile:9486675664	RT	19-08-2022
13	M/s United Inspection and Engineering Services, New No 9, Old No 22, Parthasarathypuram, North Usman Road, T.Nagar, Chennai 600 017. Phone:044-42123180, Fax: 044-28142268, Cell:Leeladhar 9444062268, E-mail:uies@sify.com.	RT	01-11-2022
14	M/s Jai Inspection Agencies, Plot No 21, Natesan Nagar, Ayanampakkam, Chennai- 600 095, Phone: 044-26533028, Fax: 044-26531770 email: engineerndt@gmail.com, jai_inspection@yahoo.com	RT.MT,PT,UT	15-06-2023

15	M/s.Naveen NDT Services, Plot No:54, Mariammal Nagar, Near SIDCO, Industrial Estate, Mathur-622515 email:naveenndt@yahoo.co.in Phone:0431-2203637, Mobile:9940743989,9842954850	RT	26-11-2022
16	M/s.A-Star Testing & Inspection Pvt.Ltd, No- 1A,Umapathy Street, West Mambalam, Chennai, India.Pin600 033. Tel:044 4851 4533, Cell:9840919166.Email:admin@astartesting.co.in	RT,UT,PT,MT	03-08-2021
17	M/s.SEA HUB Inspection Services, 1st Floor, Deepam Complex, Thiruverumbu,Trichy-620013	RT& UT,MT,PT	01-11-2022
18	M/s PERFECT INSPECTION SERVICES, Regd.Office:265, Light Industrial Area,Bhilai, Dist: Durg,Pin-490026, Ph:0788-4033857/4039576/2221729,Fax: 0788 4062759 email:pisbhilai@sify.com dkdutta7@yahoo.com09755985599	RT,UT,MT,PT	14-06-2023
19	M/s SIEVERT India Pvt.Ltd, Plot No.B3/B4, TTC Industrial Area, Opp. to Thane Belapur Road, MIDC, Digha, Navi Mumbai, Thane, Maharashtra - 400708. Office:+91 22 67859141 E-Mail : tkrudra@sievert.in	RT,UT	23-03-2023
20	M/s Test Ray's Inspection Services, S.F 413 / 3B, Mopperi Palayam,Palladam Taluk, Coimbatore-642654 Ph:0421-3269845, Mobile9600944001, 02,03 Email:tiesndt@gmail.com	RT	30-04-2024
21	M/s.BECQUEREL industries Pvt Ltd.33,Rushikesh,Ingole Nagar,Modern Co-op.Hsg.Society,Wardha Road, Nagpur.440 005.Cell +91- 9822565879.Email:info@biplndt.com	RT,UT,MT,PT	10-02-2024
22	M/s METALFAB HIGHTECH (P) LTD E 21-25, MIDC, INDUSTRIAL AREA, HINGNA NAGAR, NAGPUR-440 028 Ph:07104- 234240 e-mail:mfhpl@hotmail.com planning@metalfabhightech.com A.K.GHOSH-09922900206	RT,UT,MT,PT	21-12-2022

23	MAG Integrity Resources plot.No-1-3, Electrical & Electronic Industrial Estate, SIDCO, Thuvakudi, Trichy-620015, Ph.No: 0431-2500215,0431-4060209, Contact Person:K.Thangaiyan,MD,9443495215 E-Mail:carrier@magintegrity.com	UT,MT,PT	25-03-2023
24	M/s.Madras Radiography Engineers, 705,3rd Cross,HRBR I Block, Kalyan Nagar,Bangalore-560043 Contact Person: Damodharan.S- 9944033446,09448040882 E-Mail: mre.ndt@gmail.com	RT	25-07-2023
25	M/s RAIPUR WELDING AND NDT SERVICES PVT LTD, MD 559 Housing Board colony, Industrial Estate, Bhilai-490026,Mr.Santosh Sahu Tel: +91 9165444863, +91 9669363073 E-Mail: rwns_ndt@outlook.com	RT	30-11-2023
26	M/s. Integrity and Reliability Service, No:5/8c, Thiruvengada Nagar, Thiruverumbur, Trichy- 620013. E-Mail: iris.ndte@gmail.com , irinspectionsservice@gmail.com , Ph.No:+91-8526666028,9944674608.	UT	06-07-2023
27	M/s.UNIK NDT Inspection and Engineers Pvt Ltd, Regd.Office:23, Trikone Park, North Balia, Garia, Kolkata-700084. E-Mail: unikndt@gmail.com, info@unikndt.com Pradeep Mondal:07890009619,07059691066	RT	22-02-2024
28	M/s. VMAX Engineers, No:107, Lokamanya Thilakar Street, Kumarannagar, Padi, Chennai-vmxengineers@gmail.com Contact: Meganathan-07397788741.	UT,MT,PT	11-08-2023
29	M/s.COSMIC INSPECTION SERVICES Works:SF.No:475/2D,Sellappampalayam Road, Near LRT Foundry, Ponnadampalayam, Kanniur Post, Coimbatore-641659, E-Mail: cosmicinspectionsservices@gmail.com Mob:+91-9894670567-Mr.S.Esakki.	RT	23-07-2022

30	M/s Coimbatore Industrial Radiographers, S.F.No 221, Therkku Thottam, Othakkal Mandapam, Coimbatore-641032.Mobile:99443243201, email:cirndt@gmail.com	RT	01-11-2022
31	M/s.CUTECH SOLUTIONS INDIA PVT TLD, No-152, 2nd Floor, Tap Turbo Park, 4th lane, First Main Road,21st phase, Ambattur real estate, Chennai-600058 Phone:044-43023170 Mayuran-9043717310	RT,UT,MT	01-11-2022
32	M/s.Shri Vignesh NDT Works, Off:14 A BELL Nagar, Thuvakudi,, Trichy-620015, Phone:0431-2770551, Cell.No:9994381772 Contact person: Shri.D.Selvaganapathy, EMail: shrivigneshndtworks@gmail.com	UT,MT,PT,RT	13-06-2023
33	M/s. National Radiographic Inspection Co Pvt Ltd, A22,F/1,Brindavanam Flats,5h Avenue, Banu Nagar, Pudur, Chennai-600053 E-Mail:info@nricndt.co.in, snmoorthy@nricndt.co.in 0461-6540529,09246643275	RT	22-02-2024
34	M/s. Gama Industrial Services Pvt.Ltd, 301,Suprabath, Bejai Kapikad, Mangalore-575004 Phone: 0824 2223901 E-Mail: mlr@gamaind.com Mr.V.Sankaran ,Mobile: 09844044901.	RT	21-10-2023

ARC MAIN RATE CONTRACT – BHEL Ranipet :: Outsourcing Department

LIST OF APPROVED GALVANISING VENDORS

- 1 M/s MKK metal Sections Private Limited
Plot No:S-99 to S-108, SIPCOT Phase III
MUKUNDARAYPURAM POST , Ranipet 632406

- 2 M/S AARUSH Manufacturing Solutions Private Limited
282/4 Soorai Mottur Road , Soorai Village ,
Ranipet Dt
632505

Outsourcing Department
BAP:Ranipet

List of approved vendors for ARC Blasting-2022-23

Sl No	Vendor Code	Vendor Name
1	A29	M/s Sri Vari Industrial Works, NO.358/2B, Thiruvalluvar Nagar, Nellikuppam Mottur,Ranipet-632405
2	V66	M/s Pradeep Engineering Enterprises, S.F. No-448/3,Krishnapuram,Ekambaranellore Post,Ranipet-632405
3	S87	M/s Metal Merge Manufacturers, S.F. No-345/1,347/3,347/4, Kanigapuram Village, Kokkeri Post, Katpadi-632520
4	S72	M/s Hari Engineering Works, S.F. No-63,186,189, Eranthangal Village, Katpadi-632519
5	A78	M/s Thirupathi Heavy Engineering Industries, 466/1,RENDADI ROAD, KRISHNAPURAM, RANIPET -632405

**SECTION - VIII
LIST OF APPROVED VENDORS**

6) LIST OF APPROVED HEAT TREATMENT VENDORS

S.No	Vendor Code	Area Code	Vendor Name	ADDRESS	EMAIL ID	PHONE NO
1	30332	A05	RAMAN STRLS & ALLIED INDS.	RAMAN STRLS & ALLIED INDS. No:F-1, Ancy. Indl. Estate Thiruverumbur TIRUCHIRAPALLI 620014	ramanstructurals@yahoo.com	9443302468
2	30175	A10	KATTHIRMALAI ENGINEERING WORKS	KATTHIRMALAI ENGINEERING WORKS G1 ANCILLARY INDUSTRIAL ESTATE THIRUVERUMBUR TIRUCHIRAPALLI TIRUCHIRAPALLI - 620 014 620014	katthirmalai@hotmail.com	9942984454
3	30114	A21	VANGUARD INDUSTRIES	VANGUARD INDUSTRIES D2-B, INDL ESTATE THIRUVERUMBUR TIRUCHIRAPALLI THIRVERAMBUR 620014	van30114@yahoo.co.in	9842412672
4	30265	B21	JAYARAM ENGINEERING WORKS,	JAYARAM ENGINEERING WORKS, E-15 & 16,DEVELOPED PLOTS ESTATE, THUVAKUDI, TRICHY 620015	cmrao@jayaramengg.com	98424-55045
5	30061	C34	G.K SONS ENGG ENTERPRISES PVT.LTD.,	G.K SONS ENGG ENTERPRISES PVT.LTD., 30, MANNARPURAM TIRUCHIRAPALLI TRICHY-TOWN 620020	unit3@gksons.com	9842412262

SECTION - VIII
LIST OF APPROVED VENDORS

6) **LIST OF APPROVED HEAT TREATMENT VENDORS**

S.No	Vendor Code	Area Code	Vendor Name	ADDRESS	EMAIL ID	PHONE NO
6	31321	C62	WIRE AND WIRE PRODUCTS	WIRE AND WIRE PRODUCTS NO.46/210, PUDUKKOTTAI MAIN ROAD SEMPATTU TIRUCHY 620007	wwp620007@yahoo.co.in	9444278887
7	31490	C69	DREAMZ INDUSTRY	DREAMZ INDUSTRY 149/1B, VENGANGUDI MANNACHANALLUR TALUK TIRUCHIRAPALLI 621112	dreamzindustry2012@yahoo.com	9894661983
8	31841	F06	SREE SIVA SAKTHI ENGINEERING WORKS	SREE SIVA SAKTHI ENGINEERING WORKS PLOT No.11,12 & 13, SF.No.18/1 - C AVOOR MAIN ROAD MATHUR MATHUR-PUDUKKOTTAI 622515	ssshangers@gmail.com	9842052200
9	31203	J09	M.Se INDUSTRIES	M.Se INDUSTRIES 57B, ANAMALAI AMMAN KOVIL STREET L&T BYE PASS ROAD, VELLALORE COIMBATORE 641111	msemovers@yahoo.co.in	9843347004
10	31025	J71	MANI NAGGAPPA MOTORS MADURAI P LTD.	MANI NAGGAPPA MOTORS MADURAI P LTD. SL.NO.90/3 MADURAI-MELUR MAIN ROAD, NARASINGAMPATTI, MADURAI 625122	nagauto@gmail.com	9344101699

**SECTION - VIII
LIST OF APPROVED VENDORS**

6) LIST OF APPROVED HEAT TREATMENT VENDORS

S.No	Vendor Code	Area Code	Vendor Name	ADDRESS	EMAIL ID	PHONE NO
11	30236	L78	VUJJAAY COY INDUSTRIESS	VUJJAAY COY INDUSTRIESS F2 / 4, SIDCO INDUSTRIAL ESTATE ARIYAMANGALAM TIRUCHIRAPPALLI 620010	vcitry@yahoo.com	9952411461
12	30761	L81	AMBIGAI ENGINEERING WORKS UNIT II	Ms. AMBIGAI ENGINEERING WORKS UNIT II SF NO. 169/1,170/1A,170/1B,170/3a2, 174/3,170/11,170/3A1, PUDUKKUDI,-TANJORE DISTRICT 613402	ambigai_engg@hotmail.com	9345986491
13	30086	M16	PIONEER ENGG INDS	PIONEER ENGG INDS NO2,CHENNAI BYPASS ROAD SUBARAMANIYABURAM TIRUCHIRAPALLI TRICHY-TOWN 620020	pioneereng_ind@yahoo.co.in	9842402255
14	30084	M27	NIRMAL ENTERPRISES	NIRMAL ENTERPRISES PUGAZH NAGAR (OPP.OIL MILL BUS STOP) TIRUCHIRAPALLI KATTUR 620019	try.nent@gmail.com	94432 11693
15	30090	M52	R.K METAL INDUSTRIES	R.K METAL INDUSTRIES 32/4, III STREET,NEHRU NAGAR KAJAMALAI MAIN TIRUCHIRAPALLI TRICHY-TOWN 620023	rkmatal2003@yahoo.com	0431-2556564

SECTION - VIII
LIST OF APPROVED VENDORS
6) LIST OF APPROVED HEAT TREATMENT VENDORS

S.No	Vendor Code	Area Code	Vendor Name	ADDRESS	EMAIL ID	PHONE NO
16	30087	M68	PUNITHA ENGG WORKS	PUNITHA ENGG WORKS SF No.286/2-A, TRICHYRAPPALLI THIRUNEDUNGULAM 620015	punithaenggtry@gmail.com	9942462023
17	30861	D03	MARIA ENGINEERING ENTERPRISES,	MARIA ENGINEERING ENTERPRISES SF.NO.22/1, TRICHY-TANJORE MAIN ROAD, ASSUR POST TRICHY 620015	mariaenggenterprises@gmail.com	9865370000

Section IX

BHEL/BAP/Ranipet ::: OS-54A-ARC ::: PAGE: 01 / 01 Enquiry :652002E

List Of Standard QWI

PROCEDURE NUMBER	Rev	Effective Date	Title Of The Procedure
<u>A. GENERAL</u>			
QCP:002	02	24/04/04	Manufacture of Non-Pressure Parts
SIP:NP:06	00	15/07/96	Visual Inspection of Non-Pressure Parts
SIP:NP:07	00	15/07/96	Welding Qualification For Structural Application
BAP:NDT:RP:MT:01	03	30/08/2016	Procedure For Magnetic Particle Examination Of Ferric Material And Welded Components
BAP:NDT:RP:PT:01	03	30/08/2016	Procedure For Liquid Penetrant Examination
PR:QA:500	01	10/09/20	Procedure For Allowable For Deviations For Dimensions Without Specified Tolerances
PR:QA:505	01	14/07/93	Procedure For Storage Of Shelf Life Items Like Rust Preventive Fluids, Paints, Rubber Components, Grease, Anti Seize Compounds And Similar Components/Items
PR:QA:509	00	04/08/93	Guide Lines For NDT Requirement On Gas Cut Edges
PR:QA:512	00	31/04/94	Procedure For Control Of Surface Preparation And Painting Of Fabricated Components At Sub Contractors Works
PR:QA:590	02	24/01/18	Procedure For Surface Preparation And Painting For Bap Products
SQW-01	00	10/06/93	Standard QP For Welding
<u>B. ELECTROSTATIC PRECIPITATORS</u>			
QCP:E:002	03	30/05/13	Splicing Norms For Sheets, Plates And Other Structural Items
SQP:ESP:284	01	06/06/07	Sheet/Plate formed Component Shells, Panels & Funnel Assy/Splitters, Hopper Walls, GD Housing panels

Enquiry :652002E

Section X Quality documents

**BHARAT HEAVY ELECTRICALS LIMITED
TIRUCHIRAPPALLI 620 014 INDIA**

**QUALITY CONTROL PROCEDURE FOR
MANUFACTURE OF NON PRESSURE PARTS**





QCP:002 / 02

Page 1 of 14

Prepared by
Quality Assurance

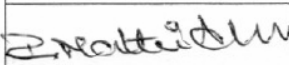
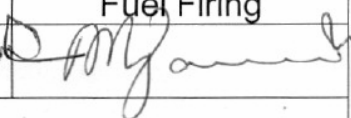
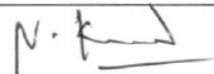
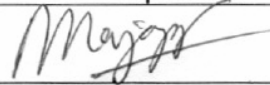
G S N Murthy

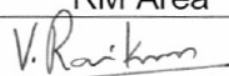

Reviewed by	Signature	
	Engineering	Structures
		
OP & C		
Manufacturing	Shops	Ancillary Development
		
Quality Assurance		
Quality Control	RM Area	OLI
		

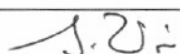
Revision No.	Date	Approved by	Signature
00	01/04/93	SM / QA	-sd-
01	01/01/95	SM / QA	-sd-
02	24/04/04	SDGM /QA	

Proprietary Data - For Internal Use Only

RECORD OF REVISIONS

Rev No...	Clause No	Details of revision
00	--	This document consolidates all the general requirements and technical disciplines covered in the various previous
01	--	All amendments issued has been regularized and editorial correction made for better clarity. Scope of machining added in this document.
02		Shaded clauses are Revised /added

1.0 SCOPE

- 1.1 This procedure details out the process control and quality requirements for manufacture of Non Pressure Parts.

2.0 REFERENCE DOCUMENTS

- 2.1 AWS D.1.1, D1.6, IS 7215 and CE: M&P 5.11.1.1, 5.11.2.1 & 5.11.2.2 as guidelines.

3.0 MATERIALS

- 3.1 CLASSIFICATION OF MATERIALS (commonly used):

<u>P No. Group</u>	<u>Specifications</u>
P1 - Group 1 - 515 Gr 60.	Carbon steel IS 2062 Gr A & B, IS 1239, IS 1161, A 36, SA
P1 - Group 2 - IS 8500.	H.Strength CS :SA105, SA 515 Gr 70, SA 299, SA 516 Gr 70,
P4 - Alloy Steel	SA 387 Gr 11 & Gr 12, SA 182 Gr F 11 & F 12.
P5 – Gr A,	SA 387 Gr 22, SA 182 Gr F 22
P6 -	SA 240-410,429
P8 - Stainless steel	SA 240 - 304 ,309,310, 316, 321, 347

Any other materials as specified in the drawings.

- 3.2 Raw materials used shall conform to the relevant specification as given in drawings and applicable TDC/PO. Any substitution of materials shall be done only with prior approval of engineering through applicable documents. Where subcontractors procure the raw materials, the same shall have valid test certificates.
- 3.3 Raw materials shall be free from visual defects like cracks, seams, laps, laminations, heavy pitting etc. When defects are noticed in visual inspection the same shall be confirmed using appropriate NDE techniques and repaired using applicable approved process .
- 3.4 All materials are procured with permitted dimensional tolerances of the material specifications and / or TDC. Wherever required, the raw materials shall be corrected prior to fabrication to achieve the required product tolerances.
- 3.5 Customer supplied materials are to be verified as per SP 0626.
- 3.6 The requirements of material traceability shall be as indicated in the respective drawings.
- 3.6.1 Product Attest "P" items indicated as in drawings are traceable to the test certificates and identified with material Specification, grade and melt number by stamping.
- 3.6.2 CERTIFIED items indicated as "C" in drawings are traceable to material Specification / grade only and identified by stamping / engraving / stenciling / painting.
- 3.6.3 Raw materials not covered by the above shall be identified by its W.O.No / material code / Specification / grade by painting / stenciling / engraving.
- 3.6.4 All subdeliveries shall be identified by its material code by painting or through name plates / tags.

3.7 When materials (including stock) are to be upgraded for special contract requirements QC shall ensure that the respective specification / contract TDC (as applicable) are complied..

4.0 FABRICATION

4.1 MARKING, CUTTING AND PREPARATION

4.1.1 Raw material shall be marked and cut to size by shearing, machining, saw cutting , flame or plasma (for SS materials) cutting. Flame cut edges shall be cleaned to remove slag. Uneven edges shall be dressed by grinding. Gas cutting notches shall be filled up by welding using compatible electrodes and ground before taking up for further fabrication.

4.1.2 Wherever raw materials supplied / available are not sufficient for the sizes required, the same can be built up using the splicing instructions given in the respective SQPs/ Drawings (Incl. Production Notes) / DCN.

4.1.3 Layout for size and shape shall be marked before cutting (for other than CNC applications) The tolerance for marking shall be maintained within + 2mm unless otherwise specified. The diagonal difference shall be within 3 mm.

4.1.4 The markings shall be punched at convenient intervals and bordered with white paint.

4.1.5 Stainless Steel (SS) materials shall be cut using plasma cutting or shearing only. Any further dressing/ grinding of cut surfaces should be done with separate and clean abrasive wheels.

4.1.5.1 The cut edges should be smoothly ground.

4.1.5.2 Notches above 3 mm or 20 % 'T' shall be thoroughly cleaned and welded by using a qualified WPS and examined visually and by LPI . The repaired surfaces are to be cleaned to bright metal surface.

4.1.6 Clip / Cleat angles above 10mm thick used for beam connections which are sheared to length shall require heat treatment.

4.1.7 Heat treatment shall be done after shearing for P4 materials $t > 12.5\text{mm}$ and for P5 materials $t > 10\text{mm}$.

4.1.8 The requirements of preheat for gas cutting are as follows:

Carbon steel	$t \leq 50\text{mm}$:	: Nil
Carbon steel	$t > 50\text{mm}$:	: 100 ° C.min.
Alloy steel (P4)	$t \leq 25\text{mm}$:	: Nil
Alloy steel (P4)	$t > 25\text{mm}$:	: 150 ° C
Alloy steel (P5)	All	: 150 ° C
Stainless steel	Not applicable	

4.1.8.1 Stress relieving for gas cut edges shall be as follows.

Material	Thickness	Heat treatment cycle
P1	> 50 mm	600 ° - 650 ° C for 30 minutes . Furnace cool (Alternatively, the cut surface can be ground / machined upto 3 mm to remove HAZ)
P4	> 16 mm	650 ° – 700 ° C for 30 minutes . Furnace cool
P5	All	680 ° - 730 ° C for 30 minutes . Furnace cool
SS (plasma)	Any	Not required

4.1.9 The prepared plates shall be visually inspected and repaired if required as per SIP:NP:06.

4.1.10 The raw materials after cutting shall be identified with relevant WO No., DU No., Part No. and Material Spec / Grade (transferred).

4.2 FORMING

4.2.1 Forming shall be done using proper tooling free from damages. Method of forming and work centre shall be identified in OPS / relevant QWI referred in PO.

4.2.2 Forming operations of sheets / plates shall be done by rolling / pressing. Circularity of rolled shells shall be checked using templates (of length > ¼ of ID).

4.2.3 Suitable nonmetallic padding shall be provided while forming of stainless steels to avoid contamination.

4.2.4 All formed components shall be checked for orientation, angle, and other dimensions as per drg. All formed parts shall have smooth finish and shall be free from bends, folds and sudden transitions.

4.2.5 Minimum thickness after forming shall be ensured whenever specified in drg.

4.2.6 Tolerances for formed components when not specified in drg. Shall be as follows

- a) St.Length / Dia, Width & Height : + 1 mm / M, 5 mm Max
- b) Verticality : 1 mm / M, 5 mm Max
- c) Squareness : 1 mm / M of length / Dia
- d) Straightness : 1 mm / M, 5 mm Max
- e) Radius : + 5 mm
- f) Bend Angle : + 2°
- g) Ovality : 1%
- h) E.P Angle : + 5° / - 2.5°
- i) Diagonal diff : 3 mm

4.3 WELDING

4.3.1 WELDING CONSUMABLES

4.3.1.1 Welding consumables conforming to the qualified welding procedures shall be used. However the following guide lines are provided.

4.3.1.2 Only Basic coated electrodes shall be used in the following cases:-

- a. All Strength welds like welds in main ceiling girders, flange butt welds in other beams, columns etc.
- b. For all structural welds, or when thickness of any one member of the weld joint is > 12 mm (unless otherwise indicated in the drawings / Qualified WPS).
- c. For welding of high tensile steels like IS 8500, SA299, SA515 Gr.70, SA516 Gr.70.

4.3.1.3 Rutile electrodes may be used for other weld joints.

4.3.1.4 All low hydrogen electrodes (EXX 16 & EXX 18) shall be dried in the baking oven at 350 deg.C for 2 hours and the electrodes shall be held at 100 deg.C until they are used.

- 4.3.1.5 All rutile electrodes (EXX 13) shall be dried at 100 deg. C for 1 hour min. and held at 100 deg.C till use.
- 4.3.1.6 Fluxes for SAW shall be dried at 200 deg.C for 1 hour min. before use. Height of flux bed while drying in pan or oven, shall not be more than 100mm.

4.3.1.7 Unless otherwise specified, SS consumable shall be baked as per Electrode manufacturer's recommendations and stored at 120 ° - 150 ° C until use.

4.3.2 FIT UP

- 4.3.2.1 Proper fit up shall be ensured before welding as per Drawing. Tack welding or mechanical clampings shall be used to maintain the fit up requirements before and during welding. Bridge pieces used during fit up shall be of ferritic for ferritic materials and stainless for stainless steel materials.
- 4.3.2.2 Dimensions of the cross sections of groove welded joint shall be within the following tolerances w.r.t. drawing requirements:

	Root not back gouged	Root back gouged
1. Root face of joint(land)	± 2 mm	Not limited
2. Root opening of joint (with out backing)	± 2 mm	+ 2 mm - 3 mm
Root opening of joint* with backing)	+ 6 mm - 2 mm	Not Applicable
3. Groove angle of of joint	+ 10° - 5°	+ 10° - 5°

*(NOTE): Root opening wider than permitted by above tolerances but not greater than twice the thickness of the thinner part or 19mm, whichever is less may be corrected by edge buildup to acceptable dimensions prior to welding. Such build up edge shall be MPI / LPI checked.

4.3.2.3 For C. S. fillet welds, the parts shall be as close as practicable and gap shall be limited to 5 mm (If gap exceeds 2 mm, the leg of fillet shall be increased by the amount of gap but in no case shall exceed 4.8 mm). For thickness 75 mm and above gap up to 8 mm can be permitted provided suitable backing is used.

4.3.2.4 For S. S. fillet welds, the parts shall be as close as practicable. Gaps 2 mm and above upto 5mm are acceptable if the fillet size is increased by an amount equal to the gap.

4.3.2.4 Parts to be joined by butt welds shall be properly aligned. An offset not exceeding 10% of the thickness of the thinner part joined can be permitted, but in no case more than 3.2 mm, is permitted.

4.3.3 PRE HEATING

4.3.3.1 Pre heating requirements for welding shall be as per Clause 4.6.7 and controls shall be exercised as detailed below. No preheating is required for stainless steels.

4.3.3.2 Preheating shall be maintained during the entire process of welding.

- 4.3.3.3 Preheating is to be done using gas burner or induction / resistance heating. The temperature must be uniform and verified using thermal chinks or thermocouples prior to start of welding as well as during welding for a width of 't' (maximum) or 75 mm whichever is less.
- 4.3.3.4 Where interpass temperature control is required during welding, the temperature must be ensured using thermal chinks / thermocouples. Inter pass nitrogen / air cooling can be adopted to maintain inter pass temperature in case of stainless steels.
- 4.3.3.5 Wherever post heating is specified, the preheating shall be continued after welding till attaining the post heat temperature and maintained for the required time and cooled slowly by wrapping suitable insulating blankets like asbestos.
- 4.3.4 Welding shall be performed using qualified procedures and qualified personnel. Edge preparation and welding details shall be as per drawing.
- 4.3.5 For items to be manufactured at subcontractor's works, for requirements of qualification of procedure and personnel as per SIP:NP: 07 shall be followed.
- 4.3.6 When double bevel welding is adopted, back gouging and grinding is to be done. Back gouged groove shall be checked with PT / MT before welding from second side.
- 4.3.7 Proper sequence of welding shall be adopted to minimise distortion. The distortion of the finished jobs, if any may be corrected by mechanical means / hot correction.
- 4.3.7.1 For welding of SS extreme care is to be taken in weld sequencing to minimize the weld distortion and shrinkage. For complex weldments a weld sequence instructions may be prepared by contractor prior to work commencement. Weld joints likely to have high shrinkage should be welded (with minimum restraints) before welding other joints providing allowance for shrinkage.
- 4.3.7.2 While cutting long web plates suitable camber may be required to compensate for the distortion during cutting and welding.
- 4.3.8 All butt welds of divider plate and guide vanes in ducts shall be flush ground inside.
- 4.3.9 The use of jigs and fixtures is recommended where ever practicable. Suitable allowances shall be provided for weld shrinkage. Proper sequence of welding shall be followed to control the distortion during welding.
- 4.3.10 All temporary attachments shall be welded with the required preheat. After their removal welded spots shall be ground flush and LPI checked.
- 4.3.11 Groove welds shall preferably be made with minimum reinforcement unless and otherwise specified in drawing / SQP. In case of butt welds, reinforcement shall not exceed 3.2 mm. and shall have gradual transition to the plane of the base material surface.
- 4.3.12 The surface of the welds shall be free from coarse ripples, overlaps, undercuts and abrupt ridges to avoid stress raisers.
- 4.3.13 Where parts of different thicknesses are welded or surface offset is more, the transition shall be made gradual by grinding / machining with 1: 2.5 taper.
- 4.3.14 Stray arcs shall be avoided to the extent possible. Arc spots if noticed shall be ground and checked by LPI / MPI. Thickness requirements shall be ensured after grinding.

4.4 WELD REPAIRS

- 4.4.1 Removal of defective weld / portions of the base material may be done by machining, grinding, chipping, gas cutting, oxygen gouging or carbon arc gouging. Defective portions of the weld shall be removed without substantial removal of sound base metal.
- 4.4.2 For under sized welds additional weld metal shall be deposited using an electrode preferably smaller than that used for making original weld limited to 4mm in diameter. The surfaces shall be cleaned thoroughly before deposition.
- 4.4.3 Defective welds/base metal shall be repaired by removing or/and rewelding as follows:
- 4.4.3.1 Overlap / excess weld metal shall be removed by grinding.
- 4.4.3.2 For excess concavity, crater, undersize & undercuts, deposit additional weld metal after cleaning the weld surface.
- 4.4.3.3 For Cracks in weld or base metal, ascertain the extent of crack by suitable NDE / acid etching, remove the crack to sound metal upto each end of the crack by arresting the ends for further propagation and reweld.
- 4.4.3.4 For weld porosity, slag inclusions & lack of fusion remove defective portions & reweld

4.5 HOT CORRECTION

- 4.5.1 Members which require hot correction are to be supported at suitable locations and mark the locations for heating.
- 4.5.2 Heat the locations marked by using neutral flame. Torches used for heating shall be moved continuously & uniformly over selected area to avoid localised over heating.
- 4.5.3 For Carbon steels the maximum temperature shall not exceed 650 ° C and shall be ensured using thermal chalks / thermocouples.

For alloy steels P4 – 705° C , P5 – 735° C temperatures are to be maintained for hot corrections

- 4.5.3.1 For Austenitic stainless steels the maximum temperature shall not exceed 430 ° C and shall be made known to inspection authorities . Otherwise , after hot correction solution annealing at 1050 – 1100 deg C is to be done.
- 4.5.3.2 For Ferritic/Martensitic/Duplex stainless steels the maximum temperature shall not exceed 315° C and shall be made known to inspection authorities . The temperature shall be ensured using thermal chalks / thermocouples.
- 4.5.4 Additional dead weights may be placed over the positive side of the bend depending upon the requirement to accelerate hot correction.
- 4.5.5 Allow for natural cooling. Accelerated cooling shall not be adopted. Remove the dead weights used after cooling.
- 4.5.6 Wherever the correction for distortion affects the weld joints, applicable NDE shall be repeated after the correction.

4.6 POST WELD HEAT TREATMENT (PWHT)

- 4.6.1 The process controls (temperature control and recording) for heat treatment shall cover the activities before, during and after heat treatment.

- 4.6.2 The weldment shall be cleaned to free of grease, oil etc. prior to heat treatment.
- 4.6.3 PWHT shall be done in a furnace or by local heating a band (including the entire weld and adjacent area of the base metal) .
- 4.6.4 The thermocouples and recording instruments shall be calibrated as per applicable standards and records maintained. The furnace shall have been qualified and calibrated.
- 4.6.5 All materials to be heat treated in furnace shall be loaded in such a way that they shall not be subjected to direct flame impingement. Jobs shall be preferably loaded on raised plat forms so that no material projects into the plane of burners. Alternatively flame deflectors may be provided in front of the burners to avoid direct flame impingement. Ensure loading of test coupons wherever applicable. **The furnace temperature shall not exceed 315 ° C at the time of loading material / weldment.**
- 4.6.6 Number of thermocouples and their location shall be decided covering maximum and minimum thickness and covering all the zones. **The temperature variation within 5 meters shall not exceed 140 ° C during heating period (above 315 ° C).**
- 4.6.7 The **temperature requirements** for Pre heating, Post Weld Heat Treatment(PWHT) & temperatures are as below.(Unless otherwise specified.)

Material	Thickness	Pre heating	PWHT Temp.	Remarks
P1 Gr 1&2	t < 38	Nil	600 – 650 ° C	a) For all butt welds in plate welded girders when t > 50mm.
	T= 39-62	100 ° C		
	t > 63	150 ° C		
P4 Gr 1&2	All	150 ° C	680 – 700 ° C	a)All butt welds in tension member b)All fabricated components when t > 16mm(Note1)
P5 Gr 1&2	All	150 ° C (Note2)	680 – 730 ° C	All welds (Note 3)
P8	300 type	120 ° C	-	
	400type	205 ° C	-	

Note 1 All fabricated structural components of P4 materials with any member above 16mm thickness, the entire assembly shall be post weld heat treated. However when size of fillet weld is less than 12 mm, PWHT is not required for non load carrying members.

Note 2 All welds on P5 material shall be post heated at 250 ° C for 2 hrs or 150 ° C for 4 Hrs, immediately following welding.

Note 3 All welds of P5 material shall be post weld heat treated. In case where the size of fillet is less than 12 mm, PWHT is not required for non load carrying members.

4.6.7.1 The **soaking time** shall be as follows:

- For P1 materials the soaking time shall be 1 hr/inch of thickness(t) (2.5 mts / mm) upto 2" and 2 hrs + 15 minutes for each additional inch for t > 2".
- For P4 & P5 materials the soaking time shall be 1 hr/inch of thickness (2.5 mts / mm) upto 5" and 5 hrs + 15 minutes for each additional inch for t > 5".

- c. For combination cycles mentioned above, calculate the minimum soaking time for individual components as 2.5 minutes/mm of the thickness of weld/material whichever is applicable. Soaking time selected for the cycle shall not exceed the limits given below:

Material	Thickness (mm)	Max. soaking time (minutes)
P1 (A,B,C), P4, P5A,	Up to 25 mm	125
P1 (A,B) + P4, P4 + P5A	26 - 50 mm	200
	51 - 80 mm	250
	81 - 150mm	375
P1C + P4, P1 + P3	Up to 25 mm	65
	26 - 50 mm	125

4.6.7.2 Unless otherwise specified, in case of mixed loads of materials not covered under simulation HT, the following heat treatment temperatures shall be followed. In such cases, guidelines for soaking can be taken from Clause 4.6.9.

For components having butt joint between P1 & P4, or P3 & P4, the cycle shall be 630 - 670° C.

Where a component has a butt joint between P4 & P5A, the cycle shall be 680 - 710° C.

Where a component has a butt joint between P1 & P3, the cycle shall be 620-660 ° C

For P1+P5A material combination, follow the WPS requirements

The following jobs shall not be combined in the same cycle during PWHT.

Separate jobs of P1 and P4 Separate jobs of P4 and P5

- 4.6.8 The following rules shall apply to establish the thickness to be used in determining the soaking time for PWHT.
- 4.6.8.1 For Butt welds, the thickness shall be the thickness of the material at the weld. For bar stock, the thickness shall be the diameter.
- 4.6.8.2 For fillet welds, the thickness shall be the throat thickness. If a fillet weld is used in conjunction with a groove weld, the thickness shall be the greater of the depth of the groove or the throat thickness.
- 4.6.8.3 For partial penetration branch welds, the thickness shall be the depth of the groove prior to welding.
- 4.6.8.4 For repairs, thickness shall be the depth of the groove as prepared for repair welding.
- 4.6.8.5 For combination of different welds in a component, maximum thickness of weld shall govern.
- 4.6.9 Requirements of Rate of Heating (ROH) above loading temperature 315 ° C and Rate of Cooling (ROC) are as given below. During heating and cooling, variation in temperature between thermocouples shall be 85 ° C maximum, unless otherwise specified.

Thickness	ROH / ROC (Max) Above / upto 315 ° C
Up to 25mm	220 ° C / hour
26 - 50 mm	95 ° C / hour
50 – 75 mm	70° C / hour
Above 75 mm	55 ° C
For S.S Matl	200 ° C / hour min (Forced air cooling)

- 4.6.10 In case of interruption during Heat treatment the following action has to be taken depending on the stage of occurrence:

Type of Heat treatment	Stage of interruption	Action
Annealing & stress relieving	Heating	Heat treat subsequently as specified
	Soaking	Heat treat subsequently for balance soaking
	Cooling	If the ROC during interruption period meets the specified rate, cool subsequently at required rate upto 400° C. Otherwise, reheat to the soaking temperature, hold for 15 minutes and then cool at the specified rate
Normalising(N) Tempering (T) & Soln. annealing (S)	Heating	Heat treat subsequently as specified
	Soaking	Heat treat subsequently for full soaking(N,S) / Balance soaking (T)
	Cooling	Not applicable

- 4.6.11 Local heat treatment can be carried out by Resistance heating or Induction heating. For local heat treatment of weld joints, width of the heated band on either side of the weld must be at least 3 times the width of the weld groove of the thickest part or 3 times the highest section thickness, whichever is greater.
- 4.6.11.1 The width of the insulation band beyond the heating band shall be at least twice the total width of the heating band.
- 4.6.11.2 A minimum of three thermocouples shall be placed such that at least one is on the weldment and the other two on the base material on either side of the weldment.
- 4.6.11.3 The winding arrangement shall be established to attain the required temperature. The initial rate of heating shall be minimum such that it stabilises at the required rate of heating before reaching 400 deg C.
- 4.6.12 After heat treatment, the charts shall be correlated with the job and cleared by QC. The chart shall contain cycle no, Date, W.O and DU details. Temperature, ROH, ROC and soaking time shall be calculated, entered in the chart and signed off by QC.
- 4.6.13 Wherever applicable the test coupons shall be tested and reports obtained to complete the clearance of heat treatment operation.

5.0 NON-DESTRUCTIVE TESTING

- 5.1 The requirement of NDE, extent and type of examination shall be as per respective product SQP and / or CQP .Wherever product SQP is not existing the following requirements shall apply.
- 5.2 Visual inspection shall be performed as per SIP:NP:06
- 5.3 RADIOGRAPHY.
- All Butt welds of Carbon steel for thickness $t \geq 32\text{mm}$
 - All butt welds of alloy steels for thickness $t > 12.0\text{mm}$ for P5 and $T > 16\text{mm}$ for P4.
 - All butt welds in monorails.
 - SS butt welds of $T > 16\text{mm}$ unless otherwise specified.

- 5.3.1 All radiographic films shall possess Firm code , RT agency, Cust. No, Part No, RT reference No. and weld location reference no. The job shall be numbered with Radiograph no.
- 5.4 MPI / LPI BEFORE PWHT
- a. All flame cut edges of Carbon steel for $t > 37.5$ mm and alloy steels for $t > 12$ mm.
 - b. All butt welds joining plate members in which one of the plate member is over 25 mm thick for Carbon steel and over 12 mm thick for alloy steel.
 - c. All fillet welds between tension flange and web.
 - d. All fillet welds joining plate members in which both the plate members are over 25 mm thick for Carbon steel and over 12 mm thick for alloy steel.
 - e. For all butt welds of CS & AS weld groove after back chipping prior to welding from second side.
 - f. All main fillet welds for SS require LPI
 - g. MPI/LPI for all fillet welds & HAZ of SA387 Gr.22 materials after HT.
- 5.5 All NDE shall be carried out by qualified personnel as per BHEL NDT procedures. Where subcontractors use their own procedures for NDE the same shall have the approval of BHEL NDTL.

6.0 MACHINING

6.1 GENERAL

- 6.1.1 Ensure of raw material identification throughout the machining process. Traceability to the contract shall be ensured by stamping or marking / painting or by tags(WO No.and DU / Part no.)
- 6.1.2 Where the material identification is likely to be removed during cutting or machining , the transfer of material identification shall be ensured.
- 6.1.3 In case of components / part processed items received from Subcontracting / other shops, ensure the completeness and clearance by QC / Customer Inspector through Inspection Reports / OPS.
- 6.1.4 Proper care shall be taken during handling of materials at all stages of manufacture. Items stored in the shop floor shall be properly identified and preserved to prevent mixup and damages / rusting / warpages.
- 6.1.5 All Machined surfaces shall be properly protected and stored. Wherever long storage is envisaged, they shall be preserved with grease / rust preventive oils and protected suitably with polythene / gunny bag or plastic peel off coatings.

6.2 MARKING

- 6.2.1 The marking on machined components shall be in such a location which will not be detrimental to the surface finish requirements of the component.
- 6.2.2 Purpose of marking is to:
- 1. Ensure availability of machining allowance.
 - 2. Identify locations for machining.
 - 3. Provide reference for setting and inspection.

6.3 PROCESS CONTROLS

6.3.1 The following shall be ensured for selection of work centers, tools, jigs and fixtures:

- a The work centre for machining shall be identified in OPS / loading sheet based on the process capability of the machine or Machine accuracy established to suit the tolerances.
- b Test hardware (Jigs, Fixtures and Templates) used as a means of inspection / process control shall have been qualified through first off trials and shall be regulated through valid number. The same shall be reflected in the OPS / loading sheet .
- c Softwares used in case of CNC / NC machines shall have been validated through trials or inspection of similar components produced and accepted.
- d All cutting tools shall have been ensured for its correctness before use. In case of regrinding of tools they shall be verified after regrinding.

6.3.2 The following shall be ensured before setting the job on the machine, during processing and after completion of machining:

- a Ensure the verticality and flatness of the job after clamping by using the reference markings or dialing the surfaces. Ensure the adequacy of clamping.
- b Ensure proper clamping of the correct tool in to the tool holders.
- c After machining the machined surfaces shall be cleaned and all corners shall be deburred. After removing from the machine they shall be properly stored.
- d Before starting reaming ensure proper material allowance for finish operation.
- e During drilling, reaming and tapping the removal of chips shall be done periodically to prevent clogging of chips. For deep drilling ensure that run out and drill travel are verified in free condition and ensure proper clamping of the tools.

6.4 INSPECTION

6.4.1 Ensure completeness of all final machining operations. Dimensional inspection shall be done with relevant drawings. Ensure use of calibrated instruments / gauges.

6.4.2 Unless otherwise specified in the drawing or SQP, the following tolerances can be used for untoleranced dimensions.

1. Linear Tolerance (:millimeters) - Medium

PERMISSIBLE DEVIATIONS FOR BASIC SIZE RANGE						
Up to 6	From 6 TO 30	from 30-120	From 120-400	From 400-1000	From 1000-2000	Above 2000
± 0.1	± 0.2	± 0.3	± 0.5	± 0.8	± 1.2	± 2.0

2. Angular Tolerance

- a. Assembly characteristics ± 0.5°
- b. Other characteristics ± 1°

7.0 FINAL INSPECTION

7.1 All dimension shall be inspected as per relevant drawings. Tolerances for fabricated items when not specified in drawings shall be as per clause 4.2.6.

8.0 CLEANING AND PAINTING

8.1 All the temporary cleats, bridge pieces shall be removed carefully so as to avoid damage to parent material. Temporary tack welds shall be ground smooth. Complete assembly shall be cleaned to remove mill scales, spatter, slag, rust, oil or grease. Surfaces shall be prepared and painted as per SIP:PP:22 (latest). Site EPs shall be applied with weldable primer. All site EP shall be protected suitably from mechanical damage.

8.2 All temporary stiffeners / attachments used for transportation and handling that are removed after site assembly shall be painted with yellow paint.

8.3 Match marking and flow direction for applicable components shall be as per the respective product SQP./Drawing

8.4 The following details shall be clearly marked with relevant details by paint, bordered and covered by one coat of transparent varnish

Project Name :
Work order number :
Component / Assly. Designation :
DU Number :
Weight :
Sub-contractor Name / Code :

8.5 Tension flanges in girders are to be identified by hard punching indicating 'TENSION FLANGE'.

8.6 For subcontracted items the firm code shall be punched and bordered with white paint.



BHARAT HEAVY ELECTRICALS LIMITED
TIRUCHIRAPALLI 620 014

QUALITY ASSURANCE

SIP:NP:06

PAGE : 1 OF 5

PROCEDURE FOR VISUAL INSPECTION OF NON PRESSURE PARTS

REV.	DATE	PREPARED	REVIEWED	APPROVED
00	15/07/96	 P.S. Narayanan	 A.R. Reddy	 V. Raghavendran

MN ICN
↓
MN RSR
↓
MN VJ
↓
112

QUALITY ASSURANCE
CAP. FILED HANDLER
MASTER COPY

REVISION STATUS		
REVISION NO:	CLAUSE NO	DETAIL OF REVISION
00	----	1)PR:QE:021/02 renumbered as SIP:NP:06. 2)Editorial corrections for clarity. 3)Clause 3.1 modified.

1.0 **SCOPE**

1.1 This procedure details out the visual inspection of all base metal surfaces and weld joints of Non pressure parts.

2.0 **REFERENCE DOCUMENTS**

AWS D 1.1 & Relevant drawings

3.0 **VISUAL INSPECTION OF GAS CUT EDGES**

3.1 Acceptability and repair of mill induced laminar discontinuities in cut surfaces

Description of Discontinuity	Repair Required
Any discontinuity 25mm in length or less	No repair
Any discontinuity over 25mm in length and 3mm max.depth	No repair
Any discontinuity over 25mm in length with depth over 3mm but not greater than 6mm.	Remove by grinding
Any discontinuity over 25mm in length with depth over 6mm but not greater than 25mm.	Completely remove and weld.
Any discontinuity over 25mm in length with depth greater than 25mm.	See CI.3.2

3.2 For discontinuities over 25mm in length with depth greater than 25mm, discovered by visual inspection of plate cut edges before welding or during examination of welded joints by radiography or ultrasonic inspection, following procedure shall be followed:

3.2.1 Where discontinuities such as (W),(X) or (Y) are determined visually prior to completing the joint, the size and shape of discontinuity shall be determined as per Fig.1.

- 3.2.2 The repair of the discontinuity by welding shall be allowed in case area of discontinuity does not exceed 4% of the plate area with the following exceptions. If the width of the discontinuity or the aggregate width of discontinuities on any transverse section, as measured perpendicular to the plate length, exceeds 20% of the plate width, the limit of 4% area shall be reduced by percentage amount of the width exceeding 20% (e.g., if the discontinuity is 30% of plate width, the area of discontinuity cannot exceed 3.6% of the plate area). The discontinuity on the cut edge of the plate shall be gouged out to a depth of 25mm beyond its intersection of the surface by chipping, or carbon arc gouging, or grinding and blocked off by welding with manual shielded metal arc process in layers not exceeding 3mm in the thickness.
- 3.2.3 If discontinuity (Z) not exceeding the allowable area is discovered after the joint has been completed and is determined to be 25mm or more away from the face of the weld, as measured on the plate surface, no repair of discontinuity is required. If the discontinuity (Z) is less than 25mm away from the weld, it shall be gouged out to a distance of 25mm from the fusion zone of the weld by chipping, air carbon arc gouging or grinding. It shall then be blocked off by welding with SMAW process for at least four layers not to exceed 3mm thickness per layer. Submerged arc or other welding process may be used for remaining layers.
- 3.2.4 If the area of discontinuity (W), (X), (Y) or (Z) exceeds the allowable limits of Cl.3.2.2, the plate or sub-component shall be rejected.
- 3.2.5 The aggregate length of weld repair shall not exceed 20% of plate length.
- 4.0 **VISUAL INSPECTION OF WELDS**
- 4.1 Visual examination of welds shall be performed after completion of welding and subsequent cooling to room temperature. However for ASTM A514 and A517 steels visual examination of welds shall be performed only after 48 hours of completion of welding.
- 4.2 All welds shall be cleaned to remove slag, spatter etc. and visually examined for defects like crack, undercut, porosity, lack of fusion etc.
- 4.3 The welds shall also be examined for size, shape and reinforcement.

4.4 ACCEPTANCE CRITERIA AND DISPOSITION DETAILS ARE AS FOLLOWS

<u>Nature of defects</u>	<u>Acc. norms</u>	<u>Disposition</u>
1) Crack, Lack of fusion, Overlap	Not accepted	Confirm by LPI/MPI, repair and retest.
2) Crater	Not accepted	Fill by weld deposit.
3) Undercut	Upto 0.8 mm accepted. > 0.8 mm not accepted.	---
4) Porosity for Butt/Fillet welds	One pore of dia ≤ 2.4 mm every 100 mm length is permitted. However pores of dia > 2.4 mm not accepted.	---

Weld contour

1) Face of fillet	Flat or concave accepted. Slightly convex accepted provided convexity is $< 0.1 S + 1.5$ mm where S is fillet size.
2) Size (Minimum)	As per drawing. Under size permitted upto 1.6 mm for a cumulative length of 10% of the total length.
3) Reinforcement	Max. 3 mm upto 19 mm. Max. 5 mm above 19 mm.

Fig.1 EDGE DISCONTINUITIES IN CUT PLATE

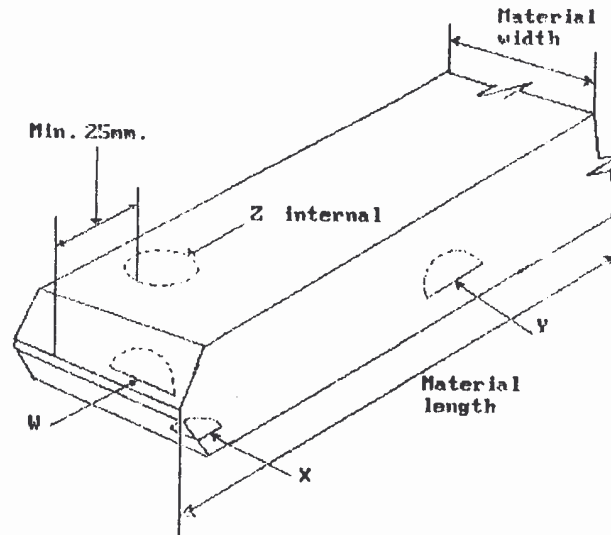

BHARAT HEAVY ELECTRICALS LIMITED
TIRUCHIRAPALLI 620 014



QUALITY ASSURANCE

SIP:NP:07

PAGE : 1 OF 23

WELDING QUALIFICATION FOR STRUCTURAL APPLICATIONS

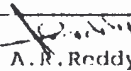
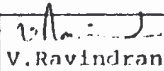
QUALITY ASSURANCE
BHP/BE/SA/1
MASTER COPY

REV.	DATE	PREPARED	REVIEWED		APPROVED
00	15/07/96	 P.S. Narayanan	 A.R. Reddy	 V. Ravindran	 V. Raghavendran

REVISION STATUS

REVISION NO:	CLAUSE NO	DETAIL OF REVISION
		1)PR:QE:172/00 renumbered as SIP:NP:07. 2)Editorial corrections for better clarity.

1.0 SCOPE

1.1 This procedure details out the requirements of

a) Welding procedure qualification for Manual and Submerged arc welding performed at sub contractors works for structural welding.

b) Qualification tests for welders and welding operators in carbon steel and alloy steel welding.

1.2 REFERENCE DOCUMENTS

1.2.1 AWS D 1.1

1.2.2 ASME Sec 1X

2.0 MATERIALS

2.1 The following materials are used for welding procedure and welder qualification.

n) Carbon steel plates/sheets	IS 8500, IS 2062 Gr A&B, ASTM A36 SA 515 Gr.70
h) Alloy steel	Carbon SA588 Gr. A, SA387 Gr12 & 22.
c) Pipes/Tubes (carbon steel)	SA 106 Gr.B, SA 210 Gr.A1

2.1.1 The materials with equivalent chemical composition also may be used.

3.0 PROCEDURE QUALIFICATION

3.1 The procedure to be qualified shall be written clearly indicating the parameters in welding procedure specification as per Table I & II.

3.1.1 The fabricator should ensure that the data given in the WPS is exhaustive and takes care of all the relevant essential variables.

3.2 Preparation of test coupons:

3.2.1 Two plates of size 400 x 250 of required thickness shall be prepared by gas cutting or shearing.

3.2.2 The test plates shall be prepared as per rolling direction of plates as given in fig1.

3.2.3 The plates shall be beveled either by gas cutting and grinding or edge planning.

- 3.2.4 The angle of bevel shall be as per WPS required to be qualified. (Single bevel edge preparation of included angle $60^{\circ} \pm 10^{\circ}$ with root gap of 0 to 3mm and land thickness of 0 to 3mm is suggested).
- 3.2.5 Matching consumables shall be used for welding test coupons as per written welding procedures.
- 3.2.6 Welders engaged in qualifying the procedure shall have adequate experience to produce a satisfactory weld and they shall not be exposed to inclement conditions during preparation of Test Coupons.
- 3.2.7 Test Coupons shall be welded in the presence of Inspecting Engineers.
- 3.2.8 Weld cleaning shall be done in the same position as the weld is being qualified.
- 3.2.9 Test Coupons shall have stamp of the Inspecting Engineers on all the test-pieces prior to cutting specimens from test coupons.
- 3.3 Visual Inspection of Plate shall be carried out as per SIP:NP:06.
- 3.4 All the test welds shall be radiographically tested before preparing mechanical test specimens. Ultrasonic testing may be done in the presence of Inspection Engineer in lieu of radiography.
- 3.5 Radiography shall be evaluated as per BHE:NDE:S:RT5.
- 3.6 Mechanical Tests:
- 3.6.1 Reduced section tension test is carried to ensure the tensile strength.
- 3.6.2 Root and face or side bend tests are carried out to confirm the soundness of welds.
- 3.6.3 Macro etch tests for ensuring soundness and fusion of welds.
- 3.7 Test Specimens:
- 3.7.1 The type and number of specimens that must be tested to qualify a welding procedure is given in Table III & IV and Fig. 1 & 2, the thickness range is based on the thickness of the test coupon welded.
- 3.8 Qualification - Types and Limitation:
- 3.8.1 Procedure qualified in groove weld qualifies fillet also as per Table III & IV and figure 3,4,5 and 6.
- 3.8.2 For range of thickness qualified (for plate and pipe) refer Table III & IV.

- 3.9 Requalification is required in the following cases.
- 3.9.1 Shield metal arc welding.
- 3.9.1.1 A change increasing filler metal strength level (e.g. a change from E 70 xx to E 80 xx and not vice versa).
- 3.9.1.2 A change from low Hydrogen type electrode to non-low hydrogen type of electrode and not vice versa.
- 3.9.1.3 A change of electrode amperage and voltages that is not within ranges recommended by the electrode manufacturer.
- 3.9.1.4 For a specified groove a change of more than + or -25% in the specified number of passes. If the area of the groove is changed the number of passes can be changed proportional to the area.
- 3.9.1.5 A change in position in which welding is done.
- 3.9.1.6 A change in type of groove (a change from V to U, for example).
- 3.9.1.7 An increase of diameter of electrode by more than 1mm over that used in the procedure qualification.
- 3.9.1.8 A change exceeding the tolerances in shape of any one type of groove involving:
- a. a decrease of included angle of the groove.
 - b. a decrease in root opening of the groove.
 - c. a increase in root face of the groove.
 - d. the omission but not inclusions, of backing material.
- 3.9.1.9 A decrease of more than 13°C in min. specified preheat and interpass temperature.
- 3.9.1.10 In vertical welding, a change in progression specified for any pass from upward to downward or vice versa.
- 3.9.1.11 The omission but not inclusion of back gouging.
- 3.9.1.12 The addition or deletion of post weld heat treatment.
- 3.9.2 Submerged arc welding
- 3.9.2.1 A change from one approved flux wire combination except for a change decreasing filler metal strength level.

- 3.9.2.2 A change from one approved flux wire combination for which there is no AWS classification
- 3.9.2.3 A change in diameter of electrodes when using an alloy flux
- 3.9.2.4 A change in the number of electrode used.
- 3.9.2.5 A change in the type of current(AC or DC) or polarity when welding quenched and tempered steel or when using an alloy flux.
- 3.9.2.6 A change of more than 10% above or below specified mean amperage for each dia of electrodes used if the wire feed speed is measured and controlled rather than the amperage,a change of more than 10% in the specified wire feed speed.
- 3.9.2.7 A change of more than 7% above or below the specified the mean arc voltage for each dia electrode used.
- 3.9.2.8 A change of more than 15% above or below the specified mean travel speed.
- 3.9.2.9 A change of more than 10% or 3mm whichever is greater,in the longitudinal spacing of the area.
- 3.9.2.10 A change of more than 10% or 1.6mm whichever is greater in the lateral spacing of the area.
- 3.9.2.11 A change of more than $\pm 10^\circ$ in the angular position of any parallel electrode.
- 3.9.2.12 A change in the angle of electrodes in machine or automatic welding of more than:
 - a) $\pm 3^\circ$ in the direction of travel
 - b) $\pm 5^\circ$ normal to the direction of travel
- 3.9.2.13 For a specified groove, a change of more than $\pm 25\%$ in the specified number of passes. If the area of the groove is changed,it is permissible to change the number of passes in proportion to the area.
- 3.9.2.14 A change in position in which welding is done
- 3.9.2.15 For a change in groove type(a change from V-groove to U-groove for example)
- 3.9.2.16 A change in the shape of any one type of groove involving:
 - a) A decrease in the included angle of the groove
 - b) A decrease in the root opening of the groove
 - c) An increase in the root face of the groove
 - d) The omission, but not inclusion of backing
- 3.9.2.17 A decrease of more than 13°C in the min. specified pre heat or interpass temperature.

- 3.9.2.18 An increase in the dia of electrode used over that called for in the WPS.
- 3.9.2.19 The omission, but not the inclusion, of back gouging.
- 3.9.2.20 The addition of or deletion of postweld heat treatment.
- 3.9.3 Qualification of fillet weld:
 - 3.9.3.1 The type and number of specimens that must be tested to qualify a fillet welding procedure are shown in Table VI.
 - 3.9.3.2 A 'T' test fillet weld as shown in Fig. 7 shall be made for each procedure and position to be used in construction. One test weld shall be the max. size single pass fillet and one test weld shall be the minimum size multiple pass fillet weld use in construction. These two fillet weld tests may be combined in a single test weldment or assembly. The weldment shall be cut perpendicular to the direction of welding at three locations as shown in Fig. 7
 - 3.9.3.3 Specimens representing one face of each of three cuts shall be macro etched after preparing the specimen with suitable finish for etching.
- 4.0. Personnel qualification: (Carbon steel and alloy steel welding)
 - 4.1 For carbon steel welding carbon steel material shall be used. For alloy steel welding alloy steel materials shall be used.
 - 4.1.1 A welder may also be qualified by welding a satisfactory procedure qualification test plate.
 - 4.2 For pipe or tube welding, welder/welding operator shall be qualified as per the welding procedure.
 - 4.3 Groove weld, plate qualification test:
 - 4.3.1 Qualification test for welders engaged in manual arc welding. Joint details of test plate are, thickness 25mm or above; single v-groove, 60° included angle; 3mm root opening (see fig.8). Minimum length of welding groove shall be 125mm. With this test, welder gets qualified for unlimited thickness.
 - 4.3.2 Qualification test for welding operators engaged in submerged arc welding. Joint detail of test plate for operators are thickness 25mm plate, single V-groove, 20° included groove angle, 15mm root opening with backing. Backing must be at least 10mm x 75mm if radiography is used for testing without removal of backing. It must be at least 10mm x 38mm for mechanical testing or if radiography is used for testing after the backing is removed. Minimum length of welding groove shall be 380mm (see fig 9). This test will qualify the welding operator for groove and fillet welding in materials of unlimited thickness.

4.3.3. Position of test weld.

4.3.3.1 Qualification in 1G(flat) position qualifies for 1G(flat) position groove welding.

4.3.3.2 If vertical welding is also anticipated, the welder shall be qualified in 3G (Vertical) position only; qualification in 3G (Vertical) position qualifies for 1G (Flat), 2G (Horizontal) and 3G (Vertical) position groove welding. If welder is qualified for 4G position, this qualifies for 1G (Flat) also but not in 3G (Vertical). Details are given below.

Qualification	Type of weld & Plate positions	position of welding qualified	
		Groove	Fillet
Weld plate groove	1G	F	F, H
	2G	F, H	F, H
	3G	F, H, V	F, H, V
	4G	F, OH	F, H, OH
	3G+4G	All	All

Note: F = Flat, H = Horizontal, V = Vertical, OH = Overhead.

4.3.3.3 When there is a change in direction of welding in 3G position, this needs re-qualification.

4.3.3.4 For fillet welding, welders need not be qualified separately. Qualification in groove welding will qualify for fillet welding also.

4.3.4 Limitations and variables:

4.3.4.1 Change in base metal within carbon steel or alloy steel material need not necessitate re-qualification.

4.3.4.2 A welder/operator shall be qualified for each of the process used.

4.3.4.3 A welder qualified for shielded metal arc welding with an electrode identified in the following table shall be considered qualified to weld or tack weld with any other electrode listed in a numerically lower group designation. In other words, a welder qualified with basic coated electrode is eligible to weld with any other electrode.

GROUP DESIGNATION	AWS ELECTRODE CLASSIFICATION		
F4	E XX 15,	E XX 16,	E XX 18
F3	E XX 10,	E XX 11,	
F2	E XX 12	E XX 13	E XX 14
F1	E XX 20,	E XX 24,	E XX 27, E XX 28

4.3.4.4 An operator qualified with an approved wire and flux combination shall be considered qualified to weld any other approved wire and flux combination for the process used in qualification test.

4.3.4.5 Weld cleaning shall be done with the test weld in the same position being qualified.

4.3.5 Visual inspection shall be carried out as per SIP:NP:06.

4.3.6 Radiographic examination of a welder's or welding operator's qualification test plate may be done in lieu of the guided bend tests as prescribed below:

4.3.7 Bend tests will be conducted on each test plate. Number and type of specimens and range of thickness qualified are as given below.

Type of weld	Thickness of test plate as welded	Plate thickness qualified	Bend tests No. of specimens		
			All positions		
			Face	Root	Side
Groove	25mm & over	Unlimited	-	-	2

4.3.8 Method of cutting bend test specimens:

4.3.8.1 Side bend specimen shall be cut and prepared from the test plate as shown in fig.10

4.3.9 Method of testing the specimen (Bend test):

- 4.3.9.1 Each side bend specimen shall be bent in a suitable jig using a mandrel of diameter 4 times the thickness of the test specimen. For test specimen of 10mm thick, for example, mandrel diameter shall be 40mm. The specimens shall be bent through 180° ('U' shape).
- 4.3.10 Test results required:
- 4.3.10.1 For bend test, the convex surface of the side bend specimen shall be examined for the appearance of cracks or other open defects. Any specimen in which a crack or other open defect is present after the bending, exceeding 3mm measured in any direction shall be considered as having failed. Cracks occurring in the corners of the specimen during testing shall not be considered.
- 4.3.10.2 For Radiographic test, the acceptance requirements are as per BIII:NDI:S:RT5.
- 4.3.10.3 In case a welder fails to meet the requirements of one or more test welds, a retest may be allowed under the following conditions.
- 4.3.10.3.1 An immediate retest may be made consisting of two test welds, of each type and position which he failed, all the test specimens of which shall meet all the requirements for such welds.
- 4.3.10.3.2A Retest may be made provided there is evidence that the welder has had further training or practice. In this case a complete retest (Single, test welds of each type) shall be made.
- 4.3.11 The welders/welding operators qualification shall be considered as remaining in effect indefinitely unless
- a) The welding operator is not engaged in the given process of welding for which welding operator is qualified for a period exceeding six months or unless
 - b) There is some specific reason to question the welding operators ability.
- 4.3.12 The manufacturer shall maintain the records of the qualification test results of the welders and the records shall be available to the Inspection Engineers for verification. A proforma for this purpose is given in Table VII.

**Procedure Qualification Record (PQR) # _____
Test Results**

TENSILE TEST

Specimen no.	Width	Thickness	Area	Ultimate tensile load, lb	Ultimate unit stress, psi	Character of failure and location

GUIDED BEND TEST

Specimen No.	Type of bend	Result	Remarks

VISUAL INSPECTION

Appearance _____
 Undercut _____
 Piping porosity _____
 Convexity _____
 Test date _____
 Witnessed by _____

Radiographic-ultrasonic examination

RT report no: _____ Result _____
 UT report no: _____ Result _____

FILLET WELD TEST RESULTS

Minimum size multiple pass	Maximum size single pass
Macroetch	Macroetch
1. _____ 3. _____	1. _____ 3. _____
2. _____	2. _____

Other Tests

All-weld-metal tension test

Tensile strength, psi _____
 Yield point/strength, psi _____
 Elongation in 2 in., % _____
 Laboratory test no. _____

Welder's name _____ Clerk no. _____ Stamp no. _____
 Tests conducted by _____ Laboratory

Test number _____
 Per _____

We, the undersigned, certify that the statements in this record are correct and that the test welds were prepared, welded, and tested in accordance with the requirements of section 5, Part B of ANSI/AWS D1.1. (_____) Structural Welding Code-Steel.
 year

Signed _____
 Manufacturer or Contractor

By _____
 Title _____
 Date _____

TABLE -III

Number and type of Test Specimens and range of thickness qualified :

Procedure qualification complete prior penetration groove welds : Dimensions in mm

PLATE THICKNESS mm	NO. OF SAMPLE WELDS PER POSITION	NDT*	TEST SPECIMENS REQUIRED				PL. THICKNESS QUALIFIED
			REDUCED SECTION TENSION	ROOT BEND	FACE BEND	SIDE BEND	
Upto 10	1	Yes	2	2	2	-	2T
Above 10 & less than 25	1	Yes	2	-	-	4	Unlimited
25 and above	1	YES	2	-	-	4	Unlimited

NOTE: All welded test plates shall be visually inspected.
*4 minimum of 150mm of effective length shall be tested by radiographic or Ultrasonic testing prior to mechanical testing.

TABLE -IV Pipes / Tubes

Number and type of Test Specimens and range of thickness qualified :

Procedure qualification complete prior penetration groove welds : Dimensions in mm

Nominal Diameter (D)	Wall Thickness (T)	NO. OF SAMPLE WELDS PER POSITION	NDT*	TEST SPECIMENS REQUIRED				QUALIFICATION RANGE	
				REDUCED SECTION TENSION	ROOT BEND	FACE BEND	SIDE BEND	DIA	THICKNESS
D < 610	3 < T ≤ 10	1	Yes	2	2	2	-	D & above	3mm t
	10 < T < 19	1	Yes	2	-	-	4	-do-	T/2 to
	T ≥ 19	1	Yes	2	-	-	4	-do-	Above
D ≥ 610	3 < T ≤ 10	1	Yes	2	2	2	-	Above 10	3mm t
	10 < T < 19	1	Yes	2	-	-	4	Above 610	T/2 to
	T ≥ 19	1	Yes	2	-	-	4	Above 610	Above

NOTE: All welded test pipes or tubes shall be visually inspected.
The full circumference of weld seam shall be tested by radiographic or Ultrasonic testing prior to mechanical testing.

TABLE-V
PROCEDURE QUALIFICATION - TYPE AND POSITION LIMITATION

WELD	PLATE POSITION	TYPE OF WELD AND POSITION OF WELDING QUALIFIED			
		PLATE		PIPE	
		GROOVE	FILLET	GROOVE	FILLET
Plate - groove (Complete joint penetration)	1G	Flat	Flat	Flat	Flat
	2G	Horizontal	Horizontal & Flat	Flat & Horizontal	Flat & Horizontal
Plate fillet	1F	---	Flat	Flat	Flat
	2F	---	Flat & Horizontal	Flat & Horizontal	Flat & Horizontal
	3F	---	Vertical	Horizontal	Horizontal
	4F	---	Over head		Over head
Pipe-groove	1G Rotated	F	F	F	F
	2G	F,H	F,H	F,H	F,H
Complete joint penetration }	5G	F,V,OH	F,V,OH	F,V,OH	F,V,OH
	6G	F,H,V,OH (Note 1)	F,H,V,OH	F,H,V,OH (Note 1)	F,H,V,OH (Note 1)
Pipe fillet	1F Rotated--		F	--	F
	2F --		F,H	--	F,H
	2F Rotated--		F,H	--	F,H(Note 2)
	4F --		F,H,OH	--	F,H,OH
	5F --		All	--	All

Note 1 Qualifies for fillet and groove welds in all positions except for complete joint Penetration groove welding of T-, Y-, and K-joints.
2. Qualifies for horizontal fillet welds on rotated pipes only.

TABLE - VI
NUMBER AND TYPE OF TEST SPECIMENS AND RANGE OF THICKNESS QUALIFIED

Test specimen	Fillet size	No. of welds per procedure	Test specimen reqd. Macro etch.	RANGE OF THICKNESS QUALIFIED	
				Plate thick	Fillet size
'T' Test Fig.2	Single pass max. size to be used in construction	1 in each position to be used	3 Faces	Unlimited	Max. tested single pass & smaller
	Multi pass - min. size to be used in construction	1 in each position to be used	3 Faces	Unlimited	Min. tested multiple pass & larger.

TABLE- VII

WELDER AND WELDING OPERATOR QUALIFICATION TEST RECORD

Welder or welding operator's name _____ Identification No. _____
 Welding process _____ Manual _____ Semi-automatic _____ Machine _____
 Position _____
 Flat, horizontal, overhead or vertical. If vertical state whether upward or downward) _____
 In accordance with Procedure specification No. _____
 Material specification _____
 Diameter and wall thickness (if pipe) otherwise joint thickness _____
 Thickness range: This qualifies _____

FILLER METAL

Specification No. _____ Classification _____ F.No. _____
 Describe filler metal (if not covered by AWS Specification) _____

Is backing strip used? _____
 Filler metal diameter and trade name _____ Flux for submerged arc or gas
 for gas metal arc or flux cored arc welding _____

GUIDE BEND TEST RESULTS

Type	Result	Type	Result

Test conducted by _____ Laboratory Test No. _____ Per. _____

RADIOGRAPHIC TEST RESULTS

Film identification	Results	Remarks	Film identification	Results	Remarks

Test witnessed by _____ Test No. _____

We the undersigned, certify that the statements in this record are correct and that the welds were prepared and tested in accordance with the requirements of 5C or D of AWS D1.1 Structural Welding Code.

Manufacturer or Contractor _____

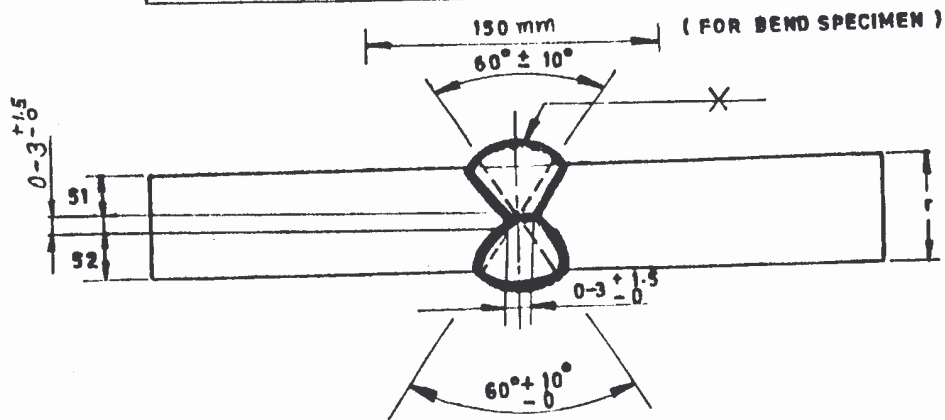
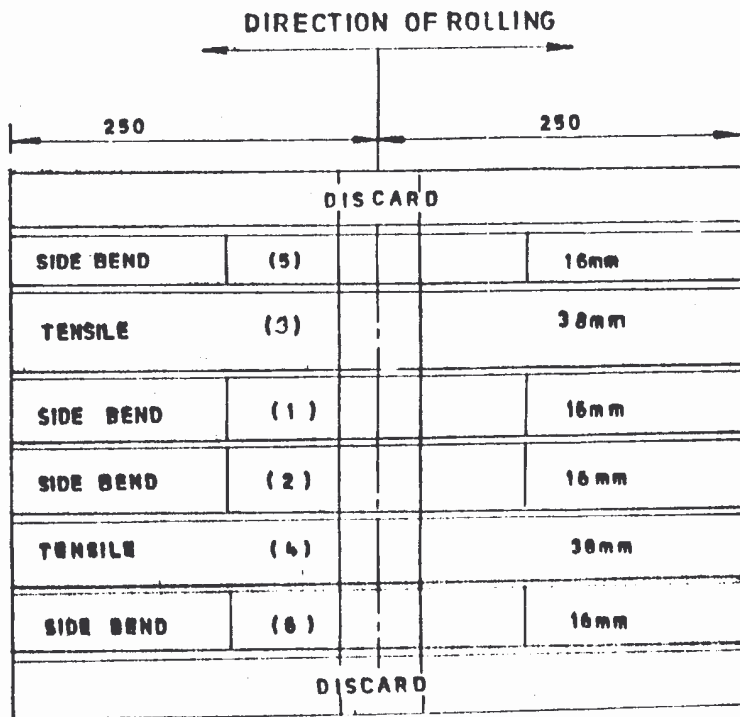

DOUBLE GROOVE WELDS MAY HAVE GROOVES OF THE EQUAL DEPTH, BUT THE DEPTH OF THE SHALLOWER GROOVES SHALL BE NOT LESS THAN ONE FOURTH OF THE THICKNESS OF THE THINNER PART JOINED.

EDGE PREPARATION DETAILS FOR TEST PLATE

FIG-1

LOCATION OF TEST SPECIMENS ON WELDED TEST PIPE

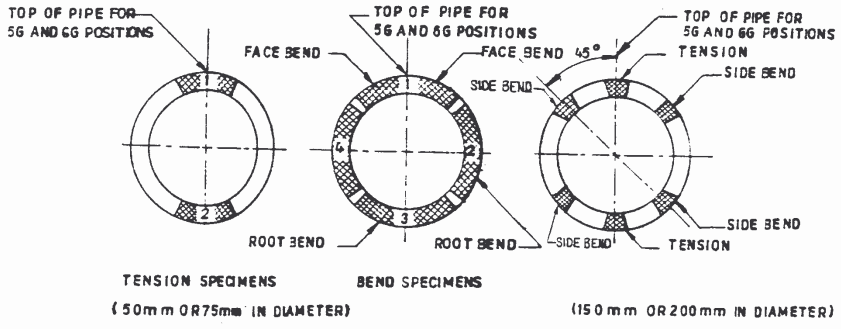

FIG-2

TEST POSITION OF TEST PLATES FOR GROOVE WELDS

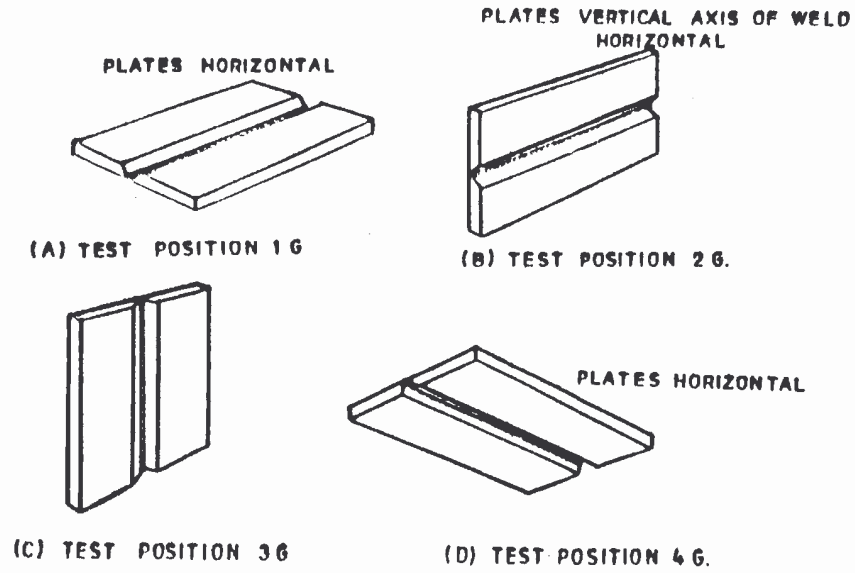

FIG.3

TEST POSITIONS OF PLATES FOR FILLET WELDS

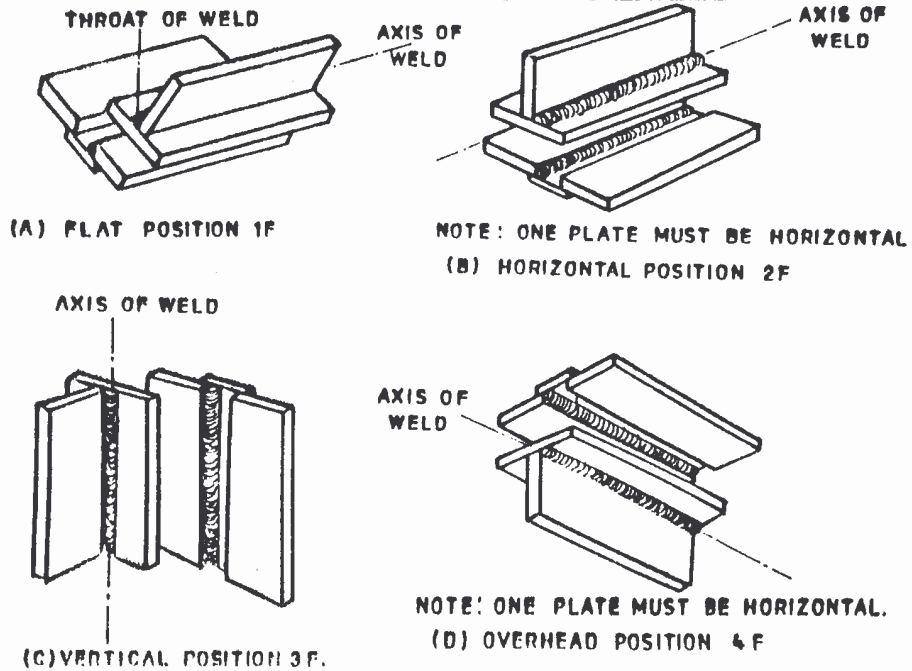

FIG - 4

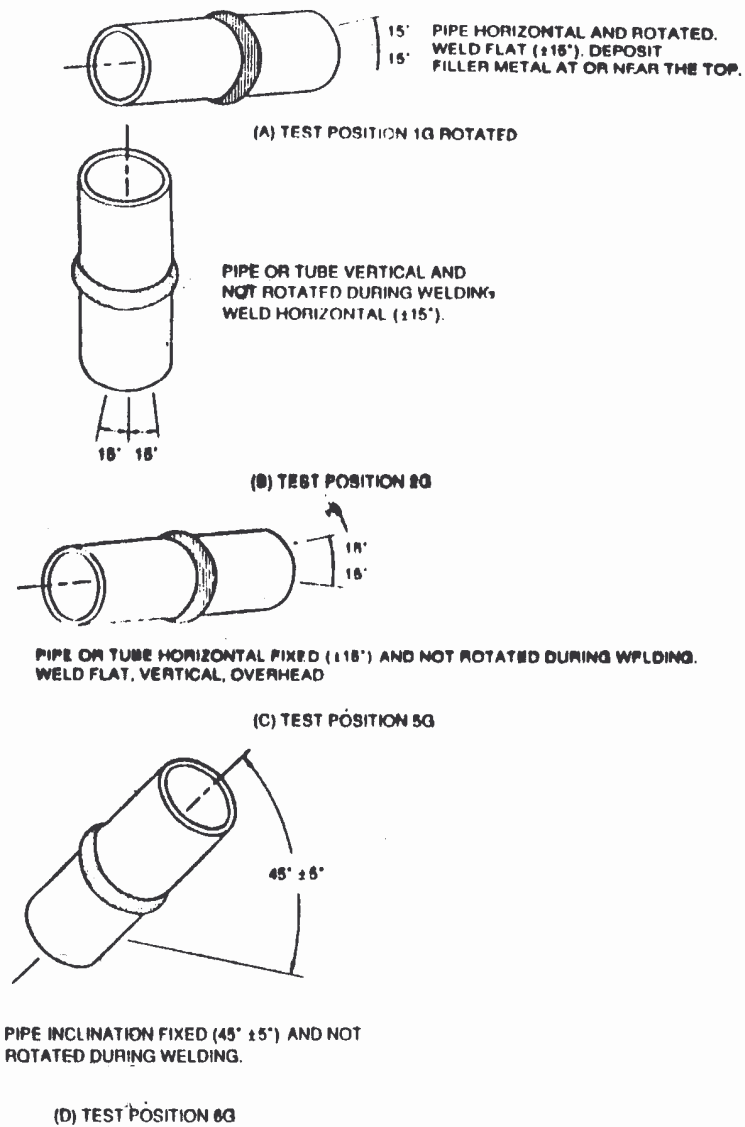
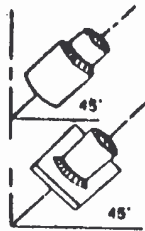

Figure 5. — Positions of Test Pipe or Tubing for Groove Welds



(A) TEST POSITION 1P
FOR FLAT POSITION
(ROTATED)



(B) TEST POSITION 2P
FOR HORIZONTAL POSITION
(FIXED)



(C) TEST POSITION 2P
FOR HORIZONTAL
POSITION (ROTATED)



(D) TEST POSITION 4P
FOR OVERHEAD POSITION
(FIXED)

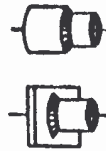

(E) TEST POSITION 6P
FOR MULTIPLE POSITION
(FIXED)

Figure .6 — Positions of Test Pipes for Fillet Welds

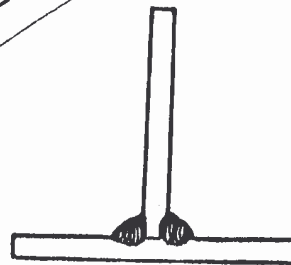
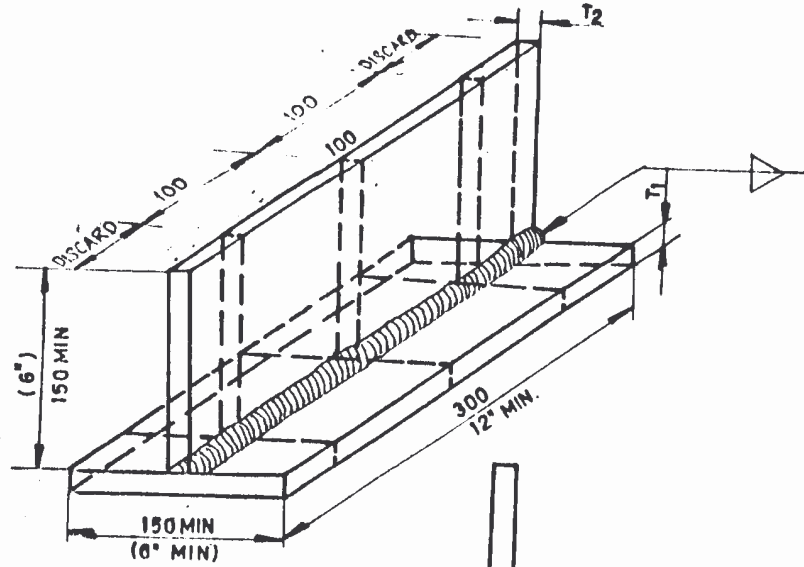

MACRO ETCH TEST SPECIMEN.

WRLD SIZE, MM	T ₁ MIN. MM	T ₂ MIN. MM
5	13	5
6	19	6
8	25	8
10	25	10
12	25	12
16	25	16
19	25	19
19	25	25

FILLET WELD SOUNDNESS TEST FOR PROCEDURE QUALIFICATION.

FIG-7

**TEST PLATE FOR UNLIMITED THICKNESS
WELDER QUALIFICATION.**

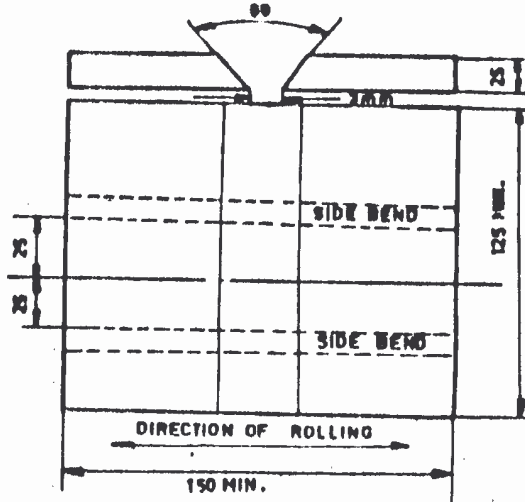

FIGURE-8

**TEST PLATE FOR UNLIMITED THICKNESS WELDING
OPERATOR QUALIFICATIONS.**

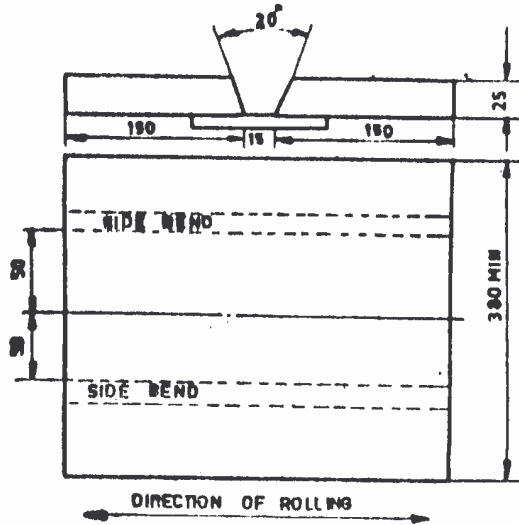
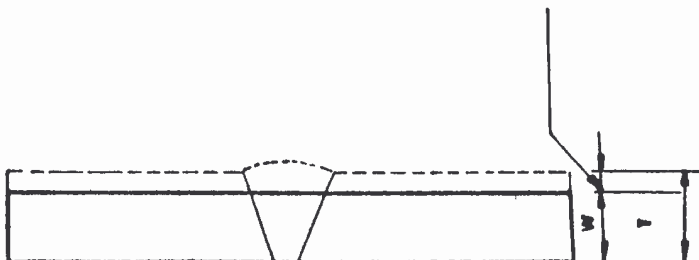

FIGURE-9

SIDE BEND SPECIMENS

MATERIAL TO BE REMOVED
WHEN PLATE THICKNESS
EXCEEDS 38MM.



FOR PLATES UP TO 38MM WIDTH 'W' EQUALS
PLATE THICKNESS 'T' FOR PLATES OVER 38MM
THICK CUT SPECIMENS IN TO MINIMUM NUMBER
OF APPROXIMATELY EQUAL STRIPS NOT
EXCEEDING 38 MM WIDTH.

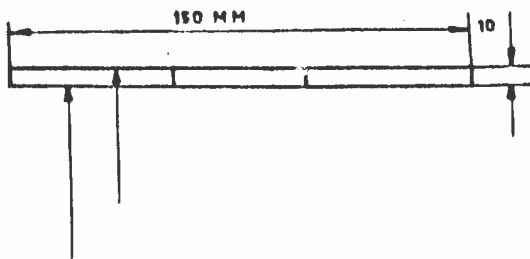

IF OXYGEN CUT NOT LESS THAN
3MM SHALL BE MACHINED FROM
EDGES.

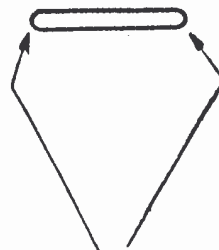



RADIUS ALL CORNERS
10MM MAX.

FIGURE-10

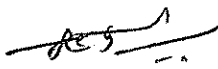

PROCEDURE
FOR
MAGNETIC PARTICLE EXAMINATION
OF
FERRITIC MATERIALS AND WELDED COMPONENTS

Prepared by	Reviewed by	Approved by
K Velladurai Dy. Engineer Level II	Kaushal Kumar Engineer Level II	Level III
		

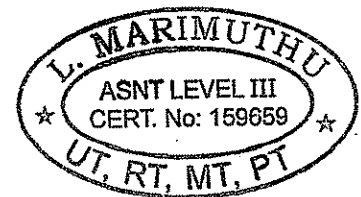

Effective Date: 30.08.2016



RECORD OF REVISION

Revision NO	Date of Revision	Reason for Revision
01	28 07 1999	Revision in entirety
02	14 08 2003	Clause modified Clause 8.2 added
03	30 08 2016	Revised in entirety based on latest standards.



1.0 SCOPE

- 1.1 This procedure describes the method, techniques and acceptance standards for Magnetic particle Examination of all shapes of ferromagnetic product forms in Boiler components Boiler Auxiliaries, pressure vessels, Heat Exchangers and Structural.
- 1.2 The examination shall include all Gas cut openings, attachment welds with a throat thickness over 6mm and on finished surface of welds as required by referencing code/section. The examination includes base material 13mm on each side of the welds.

2.0 REFERENCE

- 2.1 ASME Section V (Article 7), I & VIII (Division 1 & 2) - 2015
- 2.2 ASTM B31.1- 2012
- 2.3 ANSI / AWS D 1.1 (2010)

3.0 EQUIPMENT

- 3.1 Equipment generating half-wave rectified alternating current employing prods at the end of magnetizing cables shall be used for examination by circular magnetization method.
- 3.2 Direct / alternating current electromagnetic yokes shall be used to detect discontinuities that are open to the surface of the part by longitudinal magnetization method and to examine the surface where arcing is not permitted or prod method is not practicable.

4.0 EXAMINATION MEDIUM

- 4.1 The ferromagnetic particles used as examination medium shall be either wet or dry. Wet Particles shall be non - fluorescent type.
- 4.2 Dry magnetic particles black, gray or red in color shall be used as examination medium for examination of welds and other product forms to provide adequate contrast with the surface being examined. Particle shall be used within temperature range limitation set by the manufacturer of the particle.
- 4.3 Non fluorescent wet particles will be black or reddish brown in color that provide adequate contrast with the surface being examined. Wet particles shall be suspended in kerosene for application to the test surface by flowing or spraying. Suitable conditioning agents shall be added to the water to provide proper wetting and corrosion protection for the parts being examined.
- 4.4 The bath concentration shall be determined by measuring the settling volume through the use of pear-shaped centrifuge tube. The settling volume shall be within 1.2 ml to 2.4



ml for non- fluorescent particles per 100mL bath sample and for 0.1 to 0.4mL for fluorescent particle in 100mL bath sample.

5.0 SURFACE CONDITIONING

5.1 Preparation

5.1.1 As welded, as rolled, as cast or as forged surface is generally acceptable provided the surface irregularities will not mask the indication due to discontinuities. Otherwise surface preparation by grinding or machining may be necessary. Undercuts, Overlaps or abrupt ridges and valleys in the welds and opening shall be smoothly merged with the parent metal.

5.1.2 Prior to magnetic particle examination, ensure that the surface to be examined and adjacent area within at least 25mm of the area of interest shall be dry and free of any dirt, grease, lint, scale, welding flux, spatter, oil or other extraneous matter that would interfere with the examination.

5.1.3 Cleaning may be accomplished by detergents, organic solvents, descaling solution and paint removers, sand or grit blasting method.

5.1.4 Thin nonconductive coating such as painting will not normally interfere with the formation of indications. If nonmagnetic coatings are left on the part in the area being examined, it shall be demonstrated that indications can be detected through the existing maximum coating thickness applied.

5.2 Surface contrast Enhancement

5.2.1 When coating are applied temporarily to enhance particle contrast or if coating are left on the part being examine, it must be demonstrated that indications can be detected through the enhanced coating thickness on a test plate with machined grooves as in 16.0

5.2.2 If indications of required sensitivity could not be detected, the coating shall be removed.

6.0 METHOD OF EXAMINATION

6.1 Examination shall be made by continuous method.

6.1.1 Dry continuous magnetization method : The magnetizing current remains on while the examination medium (Dry particle) is being applied and while the excess of the examination medium is being removed.



- 6.1.2 Wet continuous magnetization method; The magnetic particle application involves bathing the surface of the part with examination medium and terminating the bath application immediately prior to cutting off the magnetizing current with two or more shots given to the part. The duration of the magnetizing current is typically on the order of 1/2 seconds.

7.0 TECHNIQUES

- 7.1 One of the following magnetization techniques shall be used.
- a) Prod Technique
 - b) Yoke Technique
 - c) Head shot and Coil Technique

8.0 TYPE OF CURRENT FOR MAGNETISATION

- 8.1 Single phase half -wave rectified current (HWDC) shall be employed for Testing with prod techniques.
- 8.2 The amperage required with single - phase Half-wave rectified current shall be verified by measuring the average current during the conducting half cycle only.
- 8.3 For Yokes, the current shall be either AC or DC.
- 8.4 For Head shot and Coil, the current shall be either HWDC or AC.

9.0 CALIBRATION

- 9.1 Ammeter of magnetizing equipment shall be calibrated as per NDT work instruction at least once a year, or after each time it has been subjected to major electrical repair, periodic overhaul or damage. If equipment has not been in use for a year or more, calibration shall be done prior to first use.
- 9.2 Lifting power of yokes
- 9.2.1 The magnetizing power of yokes shall be verified prior to use each day the yoke is used. The magnetizing power of yokes shall be verified whenever the yoke has been damaged or repaired.
- 9.2.2 Each alternating current electromagnetic yoke shall have a lifting power of at least 4.5 kg and direct current / permanent magnetic yoke shall have a lifting power of 18.kg, at the maximum pole spacing that will be used or the pole distance shall be the spacing at which the yoke lifts the stipulated weight.
- 9.2.3 Each weight shall be weighed with a scale from a reputable manufacturer and stenciled



with the applicable nominal weight prior to first use. A weight need only be verified again if damaged in a manner that could have caused potential loss of material.

10.0 EXAMINATION

10.1 Direction of magnetization

10.1.1 At least two separate examination shall be carried out on each area. During the second examination the prods/poles are spaced so that the lines of flux are approximately perpendicular to those used during the first examination. A different technique for magnetization may also be used for the second examination.

10.2 Examination Coverage: Examination shall be made with sufficient overlap to assure 100% coverage of testing.

11.0 PROD TECHNIQUE: (Fig. 1,2&3)

11.1 Magnetizing procedure: The prod electrodes are pressed firmly against the surface in the area to be examined. In order to avoid arcing a remote control switch shall be built in to the prod handles, to permit the current to be turned on after the prods have been properly positioned and to be turned off before they are removed.

11.2 Magnetizing current

11.2.1 The current shall be 100(minimum) to 125 (maximum) amperes/25mm of prod spacing for sections 19mm thick or greater.

11.2.2 For sections less than 19mm thick, the current shall be 90 to 110 amperes / 25mm of prod spacing.

11.3 Prod spacing: Prod spacing shall not be less than 75mm nor exceed a maximum of 200 mm. The prod tips shall be kept clean and dressed and the contact areas of the test surface shall be free from dirt, scale, oil etc, to minimize electrical arcing. In the open circuit voltage of the magnetizing current is greater than 25 volts, Lead, steel or Aluminum rather than copper tipped prods shall be preferred to avoid copper deposits on the part being examined.

12.0 YOKE TECHNIQUE

12.1 The pole spacing shall be between 100 mm to 150mm. The field indicator will be used to check the direction of the part magnetization.

13.0 Head shot and Coil Technique



Head shot:

13.1 Magnetizing Procedure

For this technique, magnetization is accomplished by passing current through the part to be examined. This produces a circular magnetic field that is approximately perpendicular to the direction of current flow in the part.

13.2 Magnetizing current: The current shall be 12 A/mm to 31 A/mm of outer diameter.

Coil/Longitudinal Technique:

13.3 Magnetizing Procedure

For this technique, magnetization is accomplished by passing current through a multi-turn fixed coil (or cables) that is wrapped around the part or section of the part to be examined. This produces a longitudinal magnetic field parallel to the axis of the coil. If a fixed, prewound coil is used, the part shall be placed near the side of the coil during inspection.

13.4 Magnetizing current

A) Parts with L/D Ratios Equal to or Greater Than 4.

The magnetizing current shall be within 10% of the ampere-turn value determined as follows:

$$\text{Amperes Turn} = \frac{35,000}{L/D+2}$$

B) Parts with L/D Ratios Less Than 4 but Not Less Than 2

The magnetizing ampere-turns shall be within 10% of the ampere-turns' value determined as follows:

$$\text{Amperes Turn} = \frac{45,000}{L/D}$$

C) Parts with L/D Ratios Less Than 2. Coil magnetization technique cannot be used.

Where, L is Length of the Job to be tested and D is outside Diameter of the job.

14.0 APPLICATION OF DRY PARTICLES

14.1 The dry particles shall be applied in such a manner that a light uniform dust-like coating



Settles on the surface of the area being examined. The application technique shall be such that the particles are suspended in air and reaches the examination surface in a uniform cloud with a minimum force, using a hand powder applicators (Squeeze bulb) or specially designed mechanical blower or by a spray nozzle.

14.1.1 Dry particles shall not be applied to a wet surface nor when there is excessive wind. The particles shall not be applied by pouring, throwing, or spreading with fingers.

14.1.2 Any excess powder shall be removed while the magnetization current is on and shall be with a gentle air stream without removing or disturbing particles attracted by a leakage field that may prove to be a relevant indication.

14.2 APPLICATION OF WET PARTICLES

14.2.1 The application of wet particles involves the bathing of the area to be examined, by Spraying or flowing during the application of magnetizing current.

14.2.2 Two or more shots shall be applied, but the last shot shall be applied while the bath still remains on the area to be examined and after the particles flow has been stopped. Care shall be taken to cut off the bath application before removing the magnetic field, to prevent high-velocity particle flow that wash away or remove fine or weakly held indications.

15.0 MAGNETISING FIELD ADEQUACY AND DIRECTION

15.1 By using the Pie shaped Magnetic Field Indicator, the magnetizing field adequacy and direction may be verified.

16.0 LIGHTING

16.1 Visible Light Intensity

16.2 The examination and evaluation of indications shall be performed under minimum light intensity of 100 fc (1000 lx). The light intensity shall be measured with white light meter prior to evaluation of indications or verified light source shall be used. Verification of light sources is required to be demonstrated only one time, documented, and maintained.

17.0 SYSTEM PERFORMANCE CHECK (Fig. 4)

17.1 For prod magnetization with HWAC, performance sensitivity shall be checked at least once in a shift before start of the examination on a test plate that contains machined grooves to different depths. The indication of a groove at 3mm depth from the surface of the test plate will indicate adequate sensitivity.



- 17.2 If the part is to be tested with contrast coat, the sensitivity shall be checked with the contrast coat on the surface of the test block.
- 17.3 For electromagnetic yokes, the adequacy or direction of the magnetizing force shall be verified by positioning the 'Magnetic Field Indicator' on the surface to be examined. The pattern in the indicator should be clearly developed on the surface of the block.
- 17.4 For Head shot and coil, The Ketos (Betz) ring specimen shall be used in evaluating and comparing the overall performance and sensitivity of both dry and wet, fluorescent and nonfluorescent magnetic particle techniques using a central conductor magnetization technique.

18.0 DEMAGNETISATION

- 18.1 The job to be tested using Head shot and coil technique demagnetization to be carried out.
- 18.2 The job to be tested using Yoke/Prod no demagnetization is required.

19.0 EVALUATION OF INDICATION

- 19.1 Mechanical discontinuity at the surface would be indicated by the retention of the powder or medium.
- 19.1.1 All the indication are not necessarily discontinuity indications since certain metallurgical discontinuities and magnetic permeability variation may produce similar unacceptable discontinuity indication. These non-relevant indications shall be reexamined by any other suitable NDT methods such as Liquid penetrant or macro etching.
- 19.2 Relevant indications are those which result from unacceptable mechanical discontinuities.
- 19.2.1 Linear indications are those indications in which length is greater than three times the width.
- 19.2.2 Rounded indications are circular or elliptical with the length equal to or less than three times the width.

20.0 ACCEPTANCE STANDARDS AS PER ASME (SEC I,VIII Div 1&2 and B 31.1) AND OTHERS

- 20.1 Welds and Materials
- 20.2 An indication of an imperfection may be larger than the imperfection that causes it: however, the size of the indication is the basis for acceptance for evaluation.



- 20.3 Only indications with major dimension greater than 1.5mm shall be considered relevant.
- 20.4 All surface to be examined, except as mentioned in 19.5, 19.6 and 19.7 shall be free of
- 20.4.1 Relevant linear indications
- 20.4.2 Relevant rounded indication greater than 5 mm
- 20.4.3 Four or more relevant rounded indications in a line separated by 1.5mm or less edge to Edge.
- 20.4.4 Ten or more rounded indications in any 3870 mm² (6 inch²) of surface with the major Dimension of this area not to exceed 150mm with the area taken in the most unfavorable location relative to the indication being evaluated.
- 20.5 Cut edges and openings:
- 20.5.1 All surface to be examined shall be free of
- (a) Cracks
- (b) Laminations exceeding 25mm in length.
- 20.6 In welds joining nipples to drums, spheres or headers, all slag or porosity indications Shall be investigated to assure that no leak - path exists.
- 20.7 In attachment welds of non-load carrying class, indications from crack or due to material separation are unacceptable.
- 21.0 ACCEPTANCE STANDARD FOR STRUCTURAL COMPONENTS AS PER AWS D1.1**
- 21.1 The magnetic particle acceptance criteria is based on the size of the actual discontinuity and not the size of the discontinuity as indicated by the magnetic particle inspection medium. Where discontinuity cannot be visually seen (with magnification if required) after removal of the indicating medium, evaluation shall be based on size and nature of the magnetic particle indication.
- 21.0 Statically loaded Non tubular connections
- 21.1 Cracks, Lack of Fusion, and Incomplete penetration are not acceptable.
- 21.2 Undercut-for material with thickness less than 25mm undercut shall not exceed 1.0 mm, except that a maximum 2.0 mm is permitted for a accumulated length of 50mm in any 300mm. For material equal to or greater than 25.0 mm thick, undercut shall not exceed 2.0 mm for any length of weld.



21.3 Porosity - a complete joints penetration groove welds in butt joints transverse to the direction of computed tensile stress shall have no visible piping porosity. For all other groove welds and for fillet welds, the sum of the visible piping porosity 1 mm or greater in diameter shall not exceed 10mm in any linear 25mm of weld and shall not exceed 20mm in any 300mm length of weld.

22.0 Cyclically Loaded Non tubular Connections

22.1 Undercut - In primary members, undercut shall be no more than 0.25mm deep when the weld is transverse to tensile stress under any design loading condition. Undercut shall not be more than 1.0mm deep for all other cases.

22.2 Porosity - The frequency of piping porosity in fillet welds shall not exceed one in each 100 mm of weld length and the maximum diameter shall not exceed 2.5mm. Exception for fillet connecting stiffeners to web, the sum of the diameter of the piping porosity shall not exceed 10mm in any linear 25mm of weld and shall not exceed 20mm in any 300 mm length of weld.

22.3 Complete joint penetration groove welds in butt joints transverse to the direction of computed tensile stress shall have no piping porosity.

22.4 PIPING POROSITY - (General) is elongated porosity whose major dimension lies in a direction approximately normal to the weld surface. Frequently referred to as pin holes when the porosity extends to the weld surface.

23.0 EDGE DISCONTINUITIES IN CUT MATERIALS

23.1.1 No crack is acceptable.

23.1.2 Mill induced discontinuity

23.1.3 Length 25mm and less- Acceptable

23.1.4 Length over 25mm and depth up to 3mm- Acceptable

23.1.5 Length over 25mm and depth between 3mm and 25mm ~ indications to be removed.

23.1.6 Length over 25mm and depth greater than 25mm - indications to be removed to a depth up to 25mm.

24.0 REPAIR AND RE-EXAMINATION

24.1 Whenever an imperfection is repaired by chipping or grinding or and subsequent repair



by welding is not required, the excavated area shall be blended into the surrounding surface so as to avoid sharp notches, crevices, or corners.

24.2 After a defect is thought to have been removed and prior to making weld repairs, the area will be examined by suitable method to ensure that the defect has been removed or reduced to an acceptable size of an imperfection.

24.3 where welding is required after repair of an imperfection the area shall be cleaned and repair carried out. After repairs have been made the repaired area shall be blended into the surrounding surface so as to avoid sharp notches, crevices or corners.

24.4 After repairs have been made, the repaired area shall be re-examined by methods of examination that weld originally required for the affected area.

25.0 PERSONNEL QUALIFICATION

25.1 All personnel carrying out the examination and evaluation shall be qualified to minimum Level - II as per ASNT:SNT - TC -1A Edition 2006.

26.0 FINAL CLEANING

26.1 When the inspection is concluded, the magnetic particles shall be removed by any suitable means, leaving the product in a dry and clean condition.

27.0 REPORT

27.1 Copies of the report in a standard format R 49-719-B or equivalent duly signed by a Minimum Level - II personnel shall be issued after the test.

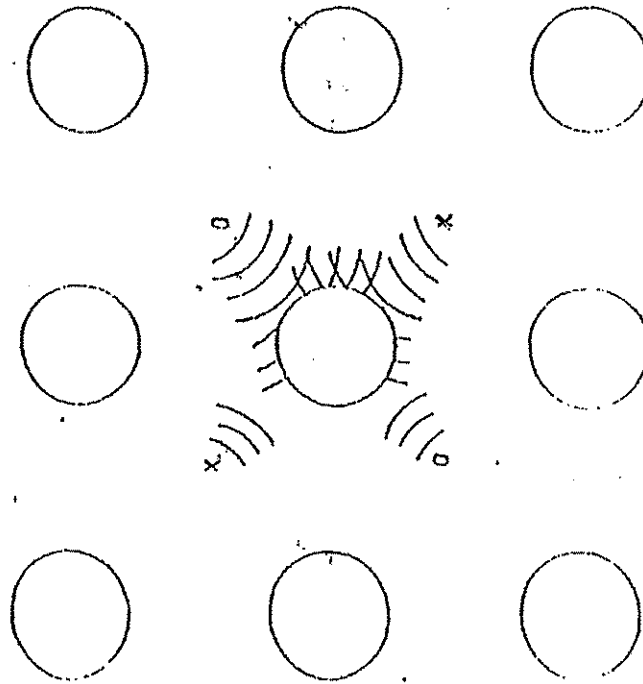

FIG (3) TECHNIQUES FOR EXAMINATION OF FILLET WELDS

0 - POSITION - 1

X - POSITION - 2

ARC BREAK LOCATION

NOTE :

- 1) PRODS must be placed on drum / header perpendicular to plate surface.
- 2) Inspection will be 100% of weld for each shot.

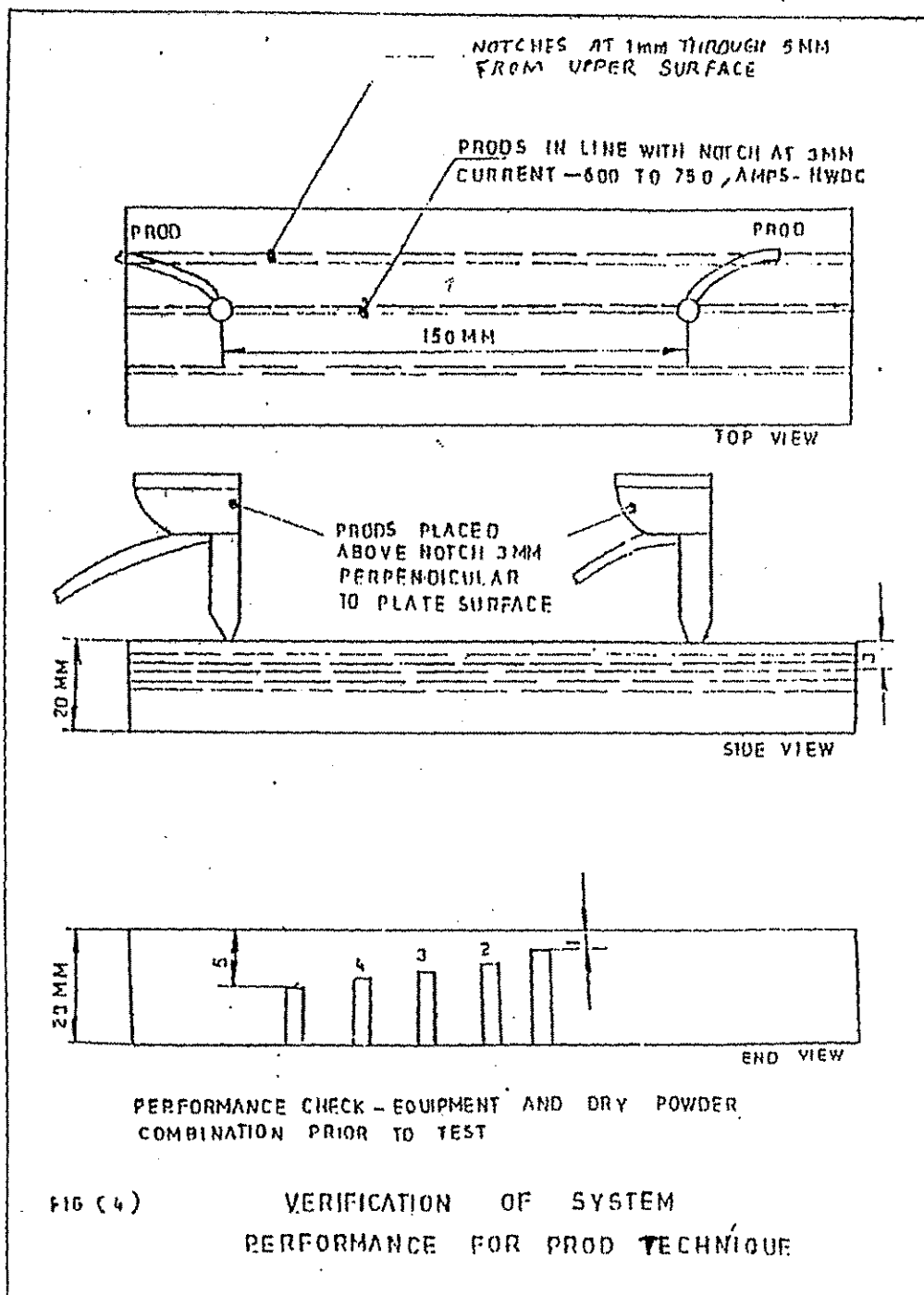



BHARAT HEAVY ELECTRICALS LIMITED
 RANIPET - 632406
 NON - DESTRUCTIVE TESTING

BHE:NDT:RP:MT:01
 REVISION 03
 PAGE 15 of 15

BHARAT HEAVY ELECTRICALS LIMITED

BAP / RANIPET - 632 406

NON - DESTRUCTIVE TESTING

MAGNETIC PARTICLE EXAMINATION

R49-719/B

REPORT NO	:		REQ DT : 02-NOV-16
REF NUMBER	:		BAY :
WORK ORDER	:		DU :
CUSTOMER	:		
PART NAME	:		
PART NUM	:		QTY :
DRAWING NO.	:		REV :
STAGE OF TEST	:		
MATL SPECIFICATION	:		THICKNESS :
WELDER NAME	:		
SURFACE PREPARATION	:		
QP NUMBER	:		CHP:
INSPECTOR NAME	:		
REMARKS	:		
DATE OF TEST	:		
PROCEDURE REFERENCE	:		
METHOD	:		
MAGNETISING CURRENT	:		PROD SPACING :
TYPE OF MAGNETISATION	:		AMPERAGE :
DEMAGNETISATION	:		
REMARKS	:		

(LEVEL-II)

OPERATOR NAME & LEVEL

ASNT LEVEL-II PT,MT,UT,RT

APPROVED BY EXTERNAL INS

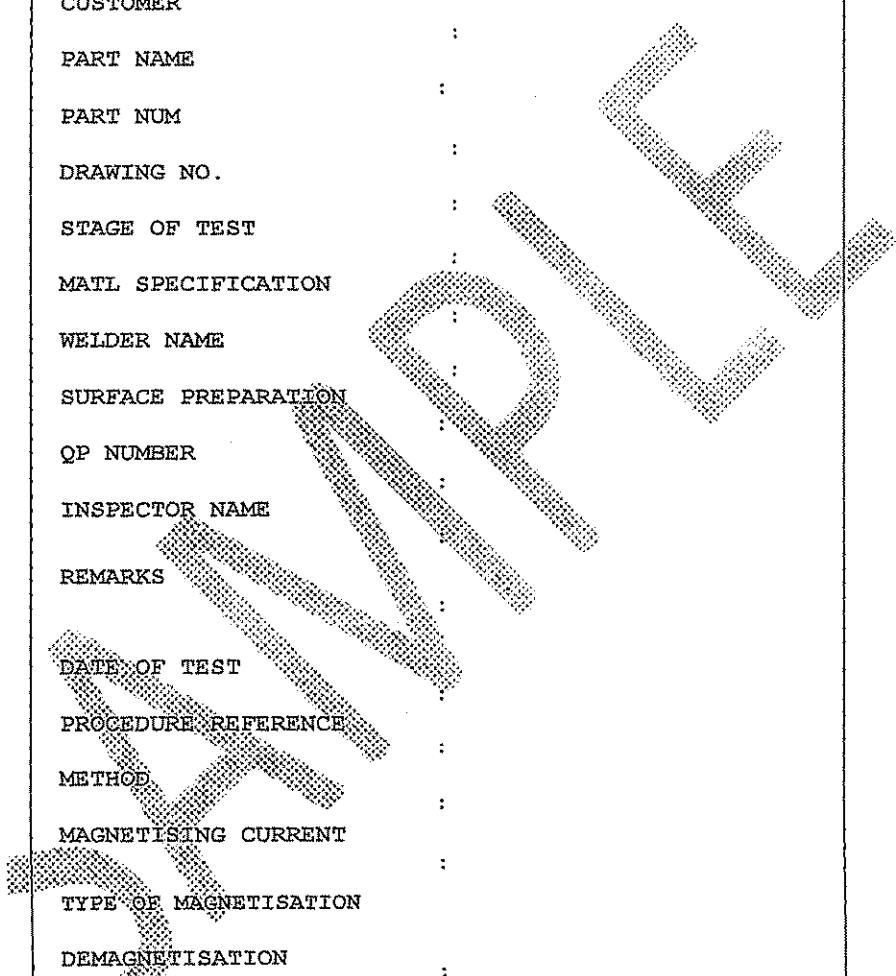

BHEL/BAP - RANIPET

APPROVED BY NDT





PROCEDURE FOR LIQUID PENETRANT EXAMINATION (Visible Method)

Prepared by	Reviewed by	Approved by
Kaushal Kumar Engineer Level II	M S Ravikumar Sr. Manager Level II	Level III
		



Effective Date 30 08 2016



1. RECORD OF REVISION

Revision No.	Date of Revision	Reason for Revision
01	28 07 1999	Revision in entirety
02	14 08 2003	Clause 2.1,2.2,2.3,12.1.2.2,12.1.3.1,12.13.2 and 13.1.2.1 modified Clause 8.2 added
03	30 08 2016	Revised in entirety based on latest standards.



1.0 SCOPE

- 1.1 This procedure defines the method, techniques and acceptance standards for liquid penetrant Examination of all shapes of ferrous and Non-ferrous product forms in Boilers, Boiler Auxiliaries, pressure vessels, Heat Exchangers and structural.
- 1.2 In pressure vessels the Examination shall include all welds around openings; attachment welds with a throat thickness over 6mm and on finished surfaces of welds as required by referencing code. The examination includes base material 13mm on each side of the weld.

2.0 REFERENCE

- 2.1 ASME Section VI Article 6, I & VIII (Division 1 &2) -2015
- 2.2 ASME B 31.1 /2015
- 2.3 AWS D 1.1 /D1.1M: 2015

3.0 EQUIPMENT

- 3.1 The term 'penetrant materials' as used in the procedure is intended to include all liquid penetrants, solvents (penetrant removers) or cleaning agents, developers etc used for 'Liquid penetrant Examination'.
- 3.2 Penetrant used shall be of solvent removable type and have a color contrast, which can be seen, readily in daylight or under normal interior illumination.
- 3.3 The cleaner used for the surface cleaning shall be an organic chemical such as Acetone or Trichloro Ethylene.
- 3.4 Developer shall be of non-aqueous suspendible type. When the developer dries, it shall form a white coating of fine powder on the part.
- 3.5 The Chemicals used for the examination of austenitic stainless steel or nickel base alloys shall be analysed for sulphur and total halogens. The residual amount of total sulphur and chlorine content shall not exceed 1% by weight.

4.0 SURFACE PREPARATION

- 4.1 In general satisfactory results may be obtained when the surface is as welded, as rolled, as forged or as cast condition. When the surface irregularities might mask the indications of unacceptable discontinuities, the surface shall be prepared by grinding or machining or any other suitable method.
- 4.2 The surface to be examined and all adjacent areas within at least 25mm shall be dry and free of any dirt, grease, lint, scale, welding flux, weld spatter, rust, paint, oil or any other extraneous matter that could obscure surface openings or otherwise interfere with the examination by preventing the penetration.



- 4.3 Shot blasting may close discontinuities at the surface and should not be used before conducting penetrant examination. If the component is shot blasted, the surface is to be etched before conducting penetrant examination.
- 4.4 Prior to the application of the penetrant, the surface is recleaned with typical industrial cleaning agents such as Acetone.

5.0 DRYING AFTER PREPARATION

After cleaning, drying of the surface shall be accomplished by normal evaporation and ensure that the cleaning solution has evaporated. The minimum time required for the cleaner to dry from the surface 60 seconds and maximum time shall be 10 minutes depending on the position.

6.0 TECHNIQUES

- 6.1 Color contrast (visible) penetrant shall be used with solvent removable penetrant process.
- 6.2 The temperature of the penetrant and the surface of the part shall not be below 5°C and not above 52°C throughout the examination period. Local heating or cooling is permitted provided the part temperature remains in the range of 5°C to 52°C during the examination.

7.0 TECHNIQUE RESTRICTIONS

- 7.1 Intermixing of penetrant materials from different families or different manufacturers is not permitted.
- 7.2 Fluorescent penetrant examination shall not follow a color contrast penetrant examination.

8.0 EXAMINATION

8.1 Penetrant Application

- 8.1.1 The penetrant shall be applied by brushing, spraying or dipping after the surface is dried. For spraying a handpump or an aerosol spray cans will be used.

8.2 Penetration time

The penetrant shall be remaining wet on the minimum and maximum period (dwell time) as given in Table 2 or as qualified by demonstration for specific application.

Table 2

MATERIAL	FORM	MINIMUM DWELL TIME	MAXIMUM DWELL TIME
----------	------	--------------------	--------------------



Aluminium, Magnesium, steel, Brass, Bronze, Titanium		TEMPERATURE RANGE	TEMPERATURE RANGE
		10 TO 52°C	10 TO 52°C
	Casting and Welds	10 Minutes	20 Minutes
	Wrought materials- Extrusions, Forging and Plates.	10 Minutes	20 Minutes

8.2.1 If the penetrant has completely dried up during the dwell time, then the surface shall be re-cleaned and reexamined.

8.3 REMOVAL OF EXCESS PENETRANT

8.3.1 After the required dwell time has elapsed, the excess penetrant remaining on the surface shall be removed by wiping with a lint free cloth, repeating the operation until most traces of penetrant have been removed. Final left out penetrant shall be removed by wiping with a clean cloth moistened with the solvent. Excessive application of the cleaner shall be avoided to prevent the possibility of removing the penetrant from discontinuities causing a decrease in the sensitivity of the test. **FLUSHING THE MATERIAL SURFACE WITH THE SOLVENT FOLLOWING THE APPLICATION OF PENETRANT AND PRIOR TO DEVELOPING IS PROHIBITED.**

8.3.2 Drying after excess penetrant removal.

8.3.2.1 After the removal of excess penetrant the surface shall be dried by normal evaporation. The minimum time required for the surface to get dried by normal evaporation is 60 seconds and maximum shall be 10 minutes. Drying of developer shall be by normal evaporation.

8.4 DEVELOPING

8.4.1 The developer shall be applied by spraying to provide uniform coating as soon as possible to the dry surface after the removal of excess penetrant. Insufficient coating thickness may not draw penetrant out of discontinuities. Excessive coating thickness may mask indications.

8.5 WET DEVELOPER APPLICATION

8.5.1 Prior to applying suspension type wet developer to the surface the developer must be thoroughly agitated to ensure adequate dispersion of suspended particles. The developer shall be applied by spraying using spray pump or aerosol spray can. The developer shall be applied over the surface in such a manner to assure complete



coverage of the part with a thin, uniform film of developer. Drying of developer shall be by normal evaporation.

8.6 DEVELOPMENT TIME

8.6.1 The surface shall be closely observed during the application of the developer to monitor the behavior of the indication, which tends to bleed-out. Developing time for final interpretation begins as soon as a wet developer coating is dry. The minimum developing time shall be 10 minutes and maximum shall be 60 minutes.

9.0 INTERPRETATION

9.1 Final interpretation shall be made within 10 to 60 minutes after the wet developer coating is dry. If the bleed - out does not alter the examination results longer periods are permitted.

9.2 The surface shall be examined in increments if the surface to be examined is large enough to complete the inspection within the prescribed time.

A minimum light intensity of 100 foot candle (1000 lux) is required to ensure adequate sensitivity during the examination and evaluation of indications, which can be achieved by a hand lamp or torch light positioning at a distance of 300mm. The light intensity shall be measured with white light meter prior to evaluation of indications or verified light source shall be used. Verification of light sources is required to be demonstrated only one time, documented, and maintained.

10.0 EVALUATION

10.1 Flaws at the surface will be indicated by bleed out of the penetrant. However localize surface irregularities such as machining marks or other surface conditions may produce false indications. Broad areas of pigmentation which would mask indications are not acceptable and such areas shall be cleaned and reexamined.

10.2 The surface shall be examined in increments if the surface to be examined is large enough to complete the inspection within prescribed time.

10.3 An indication of an imperfection may be large than the imperfection that causes it however, the size of the indication is the basis for acceptance evaluation.

10.4 Relevant indications area are those which result from mechanical discontinuities (imperfection).

10.5 Only indications with major dimension greater than 1.5mm shall be considered relevant.



- 10.6 Any indication which is believed to be non-relevant shall be regarded as a defect until the indication is either eliminated by surface conditioning or it is evaluated by other non-destructive testing and proved to be non-relevant.
- 10.7 Linear indications are those indications in which the length is more than three times the width.
- 10.8 Rounded indications are those which are circular or elliptical with the length equal to or less than three times the width.
- 10.9 Any questionable or doubtful indications shall be reexamined to determine whether they are relevant, or not.

11.0 ACCEPTANCE STANDARD

11.1 Welds and Materials (as per ASME Sec 1 and VIII Div 1&2)

11.1.1 All surface to be examined shall be free of

11.1.2 A) Relevant linear indications.

B) Relevant rounded indications greater than 5mm.

C) All relevant indications shall be investigated to assure that no leak-path exists in welds joining nipples to drums, dished-ends and headers.

11.1.3 Four or more relevant rounded indications in a line separated by 1.5mm or less edge to edge.

11.1.4 In attachment welds of non-load carrying class, indications from crack or due to material separation are unacceptable

11.2 For Power Piping(as per ASME B31.1)

11.2.1 Indications whose major dimensions greater than 2.0mm shall be considered relevant.

11.2.2 The following relevant indication are unacceptable:

- a. Any crack or linear indications.
- b. Rounded indication whose dimensions greater than 5.0mm.
- c. Four or more rounded indication in a line separated by 2.0mm or less edge to edge.
- d. Ten or more rounded indication in any 3870mm² of surface with the major dimensions of this area not to exceed 150mm with the area taken in the most unfavorable location relative to the indications being evaluated.



12.0 WELDS MADE TO STRUCTURAL WELDING CODE AWS D 1.1

12.1 For statically and cyclically loaded non-tubular connections made to AWS code the acceptance of any discontinuity shall be based upon a visual examination of the discontinuity after the removal of developer medium and evaluated for its nature and size. Where the discontinuity cannot be seen after removal of the developer medium either directly or using magnifying glass evaluation shall be based on the size and nature of liquid penetrant indication.

13.0 ACCEPTANCE STANDARD (AS PER AWS)

13.1 Statically loaded non-tubular connections.

13.1.1 Indications from cracks, lack of penetration and lack of fusion are not acceptable.

13.2 Porosity.

13.2.1 Complete joint penetration groove welds in butt joints transverse to the computed tensile stress shall have no visible piping porosity.

13.2.2 For all other groove welds and for fillet welds, the sum of the visible piping porosity of 1.0 mm or greater in diameter shall not exceed 10 mm in any linear 25 mm of weld and shall not exceed 20 mm in any 300 mm length of weld.

13.3 Undercut

13.3.1 For material less than 25 mm thick, undercut shall not exceed 1.0 mm except that a maximum 2.0 mm is permitted for an accumulated length of 50 mm in any 300 mm

13.2 For material equal to or greater than 25 mm thick undercut shall not exceed 2.0 mm for any length of weld.

14.0 Cyclically loaded non-tubular connections.

14.1 Indications from Cracks, Lack of penetration and lack of fusion are not acceptable in any welds.

14.2 Porosity

14.2.1 Complete joint penetration groove welds in butt joints transverse to the direction of computed tensile stress shall have no piping porosity. For all other groove welds, the frequency of piping porosity shall not exceed one in 100mm of length and the maximum diameter shall not exceed 2.5 mm.

14.2.2 The Frequency of piping porosity in fillet welds shall not exceed one in each 100mm of weld length and the maximum diameter shall not exceed 2.5mm. EXCEPTION for fillet welds connecting stiffeners to web, the sum of the diameter of piping porosity



shall not exceed 10mm in any linear 25mm of weld and shall not exceed 20mm in any 300mm length of weld.

14.3 Undercut.

14.3.1 In primary members, undercut shall not be more than 0.25mm deep when the weld is transverse to tensile stress under any design loading condition. Undercut shall not be more than 1mm deep for all other cases.

15.0 REPAIR AND RE-EXAMINATION

15.1 Whenever an imperfection is repaired by chipping or grinding the excavated area shall be blended into the surrounding surface so as to avoid sharp notches, crevices or corners.

15.2 After a defect is thought to have been removed and where welding is required after repair, the area shall be examined for removal of defects, area cleaned and repair carried out. The repaired area shall be blended into the surrounding surface as in 14.1 and re-examined by the liquid penetrant or any other NDT methods originally required for the affected area.

16.0 PERSONNEL QUALIFICATION

16.1 Wherever penetrant examination is required by the referencing code, the same shall be conducted by Level I and evaluated by a personnel qualified to minimum Level II as per ASNT SNT-TC-1A Edition 2006.

17.0 POST CLEANING

17.1 After the examination and evaluation is completed all penetrant testing material shall be removed from the surface, so that it will not interfere with the subsequent processing or service requirements.

18.0 REPORTING

18.1 Where penetrant test is mandatory, a copy of the report signed by personnel certified to minimum Level-II will be issued in format R49-720B or equivalent, after completion the examination.



BHARAT HEAVY ELECTRICALS LIMITED

BAP / RANIPET 632 406

R49-720/B

NON-DESTRUCTIVE TESTING
LIQUID PENETRATION TEST

REPORT NO	:	REQ DT	:
REF NO	:	BAY	:
WORK ORDER	:	DU	:
CUSTOMER	:		
PART NAME	:		
PART NUM	:	QTY	:
DRAWING NO.	:	REV	:
STAGE OF TEST	:		
MATERIAL SPECIFICATION	:	CHP	:
SURFACE CONDITION	:		
QP REFERENCE	:		
REMARKS	:		
QC-INSPECTOR NAME	:		
DATE OF TEST	:		
PROCEDURE REFERENCE	:		
TYPE OF PENETRANT	:		
PENETRANT REMOVER	:		
TYPE OF DEVELOPER	:		
TEMPERATURE	:		
DEWELL TIME	:		
REMARKS	:		

(LEVEL-II)

OPERATOR NAME & LEVEL

APPROVED BY NDT

APPROVED BY EXTERNAL I

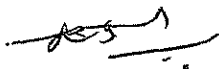
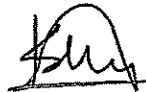
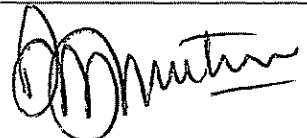

PROCEDURE FOR RADIOGRAPHIC EXAMINATION OF BUTT WELDS IN STRUCTURES OF BOILER COMPONENTS

Prepared by	Reviewed by	Approved by
K Velladurai Dy. Engineer Level II	Kaushal Kumar Engineer Level II	Level III
		

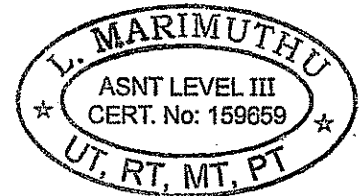

Effective from 21.09.2016



RECORD OF REVISION

Revision No	Date of Revision	Reason for Revision
01	11-02-2005	Revision in entirety
02	21-09-2016	Revision in entirety based on latest standard



1.0 SCOPE

- 1.1 This procedure describes the testing method and acceptance standards for the radiographic examination of butt welds in structures having thickness up to 75mm of boiler components, rotating parts and is applicable wherever specified in the concerned quality control procedures.

2.0 REFERENCE

- 2.1 ASME Section V 2015 (Article 2)
- 2.2 AWS D.1.1. Structural welding code - Steel 2015
- 2.3 ASTM E 94
- 2.4 ASME SECTION VIII DIV 02

3.0 SURFACE PREPARATION

- 3.1 The finished surface of the weld may be flush with the plate or have a reasonably uniform reinforcement, not to exceed 3.0 mm. Both surfaces of the test assembly in the area of the weld shall be smooth enough such that the resulting radiographic contrast due to any remaining irregularities cannot mask or be confused with that of any objectionable defect or the contract documents require the removal of weld reinforcement.

4.0 EQUIPMENTS AND MATERIALS

4.1 Radiation Sources

- 4.1.1 Iridium-192 Source may be used for radiography.

4.2 Film

- 4.2. The film used for radiography shall be generally the following brands of film.

- Kodak - Industrex AA 400 /T 200/ M
- Agfa Gevaert – Agfa D7 / D5 / D4
- Laser D7 / D5 / D4

- 4.2.2 Other brands of films shall be used subjected to approval as per procedure No: NDT: WI: 010.



- 4.3.1 Lead Intensifying Screens shall be used to improve the quality of the radiograph. Screen shall be of thickness not less than 0.13mm. Suitable lead backing shall be used to avoid back scatter wherever required. Fluorescent screens shall not be used.
- 4.3.2 All intensifying screens shall be handled carefully to avoid dents, scratches, dirt or grease on the active surfaces and shall not cause any false indications due to the defective screens. Screens shall be in direct contact with the film. Screens showing evidence of physical damage should be discarded.

5.0 TECHNIQUES OF RADIOGRAPHY

- 5.1 Radiographs shall be made with single source of radiation and the source is positioned so that the center of the cone of the radiation beam falls normal to the axis of the weld and centered with respect to the length and width of the weld being examined.
- 5.2 A single-wall exposure technique shall be used for radiography. In single-wall technique, the radiation passes through only one wall of the weld (material) which is reviewed for acceptance of the radiograph. The film being exposed shall be close to the surface of the weld, opposite to the radiation source and parallel to the front surface of the work to avoid enlargement and distortion of image. As Gamma radiations are divergent in nature the radiographic image or the structure within the weld will be larger than the object or structure itself.
- 5.3 The width of the film shall be sufficient to depict all portions of the weld joint including the heat affected zones and shall provide sufficient additional space for required IQI and film identification without infringing upon the area of interest in the radiograph.
- 5.4 The source object distance, the perpendicular distance from the radiation source to the object, shall be as large as possible as the degree of enlargement will decrease with the increase in distance.
- 5.5 The source to object distance shall neither be less than seven times the maximum thickness of the weld plus reinforcement and backing if any, under examination nor the length of the film being exposed in a single plane.
- 5.6 Films shall have sufficient length and shall be placed to produce at least 12.5 mm of film exposed to direct radiation from the source beyond each free edge where the weld is terminated.

6.0 IDENTIFICATION OF RADIOGRAPHS

- 6.1 Each butt weld will have an identification number to identify the weld and segments. These number and location marker will appear as a permanent image on the radiographs.
- 6.2 Location markers shall be placed on the source side of part. Outer edges of the weld shall be identified by keeping segment numbers or alphabetic letters on one edge and the arrows on the other edge beneath the segment number or letter, but clear from the

edges, using lead markers.



- 6.3 The weld shall be divided into suitable segments in such a way that the density at the extremities of the radiographs shall not be less than 15% of the density at the middle.
- 6.4 Radiographs shall be taken with sufficient overlap, such that no area will be left untested.
- 6.5 Information required to show on the radiograph shall include the contract identification, initials of the radiographic inspection co., initials of the fabricator, the radiography identification marks, date of radiography and weld repair number, if applicable. These identification numbers shall be placed 19 mm away from the weld edge.
- 6.6 To identify repairs, letters R1,R2,R3 etc. shall be placed in addition to the original system of identification. Suffix RT will represent retake without repair and GRE or MRT for grind and retake.

7.0 DENSITY OF RADIOGRAPHS

- 7.1 The transmitted radiographic film density through the body of appropriate hole type IQI and the area of interest shall be 2.0 minimum and 4.0 maximum for single wall viewing. A step wedge comparison film or a densitometer will be used for judging film density. A tolerance of 0.05 in density is allowed for variation between densitometer readings
- 7.2 If the ratios of thicker weld section to thinner weld section is 3 or greater radiographs shall be exposed to produce a density of 3.0 to 4.0 in thinner section. When this is done densities less than 1.8 will be accepted in the thicker section.
- 7.3 If the density of radiograph anywhere through the area of interest varies by more than minus 15 % or plus 30% rounded to the nearest 0.1 from the density through the body of the IQI within the minimum/ maximum allowable density ranges specified in the para 7.1, then an additional IQI shall be used for each exceptional area, one shall represent the lightest area and the other the darkest area of interest.

8.0 STEP WEDGE FILM

- 8.1 The density of step wedge comparison films calibration shall be verified by calibrated densitometer.

9.0 SCATTERED RADIATION

- 9.1 Back scattered radiation shall be checked by attaching lead letter 'B' of 13mm in height and 1.5 mm in thickness on the back of each film holder during exposure. If the lighter image of 'B' appears on the radiograph as an image on darker background, the radiograph shall be considered unacceptable . A dark image of 'B' on a lighter background is not a cause of rejection.

10.0 IMAGE QUALITY INDICATORS (IQI) as per AWS D1.1

10.1 IQI shall be of plate and hole type. The Designated hole type IQI with essential hole shall be as given in Table-1, below:

TABLE-1

Material thickness, IQI Nominal Single Wall Thickness range mm	Designations and Essential Holes.			
	IQI			
	Source side		Film side	
	Design.	Essn. Hole	Design.	Essn. Hole
Upto 6 inclu.	10	4T	7	4T
Over 6 thru 10	12	4T	10	4T
Over 10 thru 16	15	4T	12	4T
Over 16 thru 20	17	4T	15	4T
Over 20 thru 25	20	4T	17	4T
Over 25 thru 32	25	4T	20	4T
Over 32 thru 38	30	2T	25	2T
Over 38 thru 50	35	2T	30	2T
Over 50 thru 65	40	2T	35	2T
Over 65 thru 75	45	2T	40	2T

10.2 IQI shall conform to fig 6.9 of AWS D1.1 and shall be made of carbon steel or type 304 stainless steel. For welds, the thickness on which the IQI is selected shall be the nominal single wall thickness plus the reinforcement.

10.3 The hole type IQI shall be placed adjacent to the weld except for instances where the weld material or the geometrical configuration makes it impracticable to place the IQI, in which case the IQI shall be placed on the weld metal itself.

10.4 Number of IQI

10.4.1 For welds joining nominal equal thickness:



- 10.4.2 Where a radiograph represent 255 mm or greater of weld length, IQI shall be placed at the ends of the segment, one on either side of the weld. Where a radiograph represents less than 255 mm of weld, one IQI shall be placed at the center away from the weld edge.
- 10.4.3 For welds at a transition in thickness:
- 10.4.4 Where a radiograph represent 255mm or greater of weld length, two IQI on either end of the weld on thinner side and one IQI on thicker side at the center of the weld shall be placed 10mm away from the weld. The IQI on the transition thickness shall be based on the maximum thickness under the IQI. Similarly for weld length less than 255mm one IQI shall be placed on thinner side and one on transition side.
- 10.5 A shim of material radiographically similar to the weld metal shall be placed under the IQI, if needed, so that the radiographic density throughout the area of interest is not more than minus 15 % from the radiographic density through the designated IQI adjacent to the essential hole. The dimension of the shim shall be 3mm more than the IQI at least in 3 sides.

11.0 GEOMETRIC UNSHARPNESS (U_g)

- 11.1 The maximum value for geometric unsharpness will be



- b. The greatest type of any porosity or fusion type discontinuity (such as slag, lack of fusion and incomplete penetration) that is 2mm or larger, in greatest dimension shall not exceed the size 'B' indicated in figure 1 for the effective throat or weld size involved. The maximum size limitations 13 mm shall apply to all weld effective throat of greater than 38mm also.
- c. The distance from any porosity or fusion type discontinuity described above to another such discontinuity, to an edge, or to the toe or root of any interacting flange to web weld shall not be less than the maximum clearance allowed 'C' indicated in fig I for the size of discontinuity under examination.
- d. Discontinuities having a greatest dimension of less than 2mm shall be unacceptable if the sum of their greatest dimension exceeds 10 mm in any 25mm length of weld.
- e. Adjacent discontinuities spaced less than the minimum spacing required by fig I shall be measured as equal to the sum of total length of discontinuities plus the length of the space between them and evaluated as a single discontinuity.

13.2 For welds subject to cyclically loaded non-tubular compression member:

13.2.1 The following type of discontinuities shall not be acceptable.

- a. Any type of crack.
- b. The greatest dimension of any porosity or a fusion type discontinuity that is 3mm or larger, in greatest dimension shall not exceed the size 'B' nor shall the space between adjacent discontinuities be less than the minimum clearance allowed 'C' indicated by figure II, for the size of discontinuity under examination. The maximum size limitation 19 mm applicable to weld thickness 38mm as shown in fig II shall apply to all weld sizes greater than 38 mm.
- c. Discontinuities having a greatest dimension of less than 2mm shall be unacceptable, if the sum of their greatest dimension exceeds 10mm in any 25mm length of weld.
- d. Adjacent discontinuities not separated by two times the length of the largest discontinuity shall be measured as one length equal to the total length of discontinuity inclusive of the space in between and evaluated as a single discontinuity.

13.3 Welds in different parts of Impeller Assembly and other Rotating Machineries.

- 13.3.1 a. Any indication which is interpreted to be a crack or lack of fusion or lack of penetration is not acceptable regardless of their length.
- b. Indications of slag inclusions are not acceptable if the length is more than 5mm.



- c. Successive indication of slag inclusions less than 5mm in length shall be separated by at least 5 times the length of the longer of the two indications.
- d. The aggregate length of successive slag inclusions shall not exceed 't' in a length of 12't' ('t' is the thickness of the thinner of the section joined)
- e. Rounded indications whose major dimension is greater than 0.8 mm are considered to be relevant.
- f. Rounded indications whose major dimension is greater than 3.2 mm are not acceptable.
- g. Isolated indication of maximum size of 3.2 mm is permissible provided it is separated from the adjacent indications by at least 25 mm (fig III).
- h. Randomly distributed rounded indications are acceptable as per chart in figure III (Figure 4-5 of ASME Section VIII, Appendix 4)
- i. No cluster of rounded indication is acceptable.

14.0 PERSONNEL QUALIFICATION

14.1 Personnel performing examination shall be qualified in accordance with NDT:WI:006

- 1) Operator Minimum Level I
- 2) Film Evaluation Minimum Level II

15.0 REPORT

15.1 After the evaluation, report shall be issued in the radiographic examination report form no:R49-718/A or equivalent. Wherever required, approval shall be obtained from the concerned external inspection agency.

15.2 The tests, reports and radiographs will be preserved for five year or till the documents are signed, whichever is earlier.

16.0 SAFETY

16.1 Radiography shall be performed in accordance with all applicable safety requirements as specified in Safety Procedure BHEL: NDT: RP: SAF: 01

.....

FIGURE I

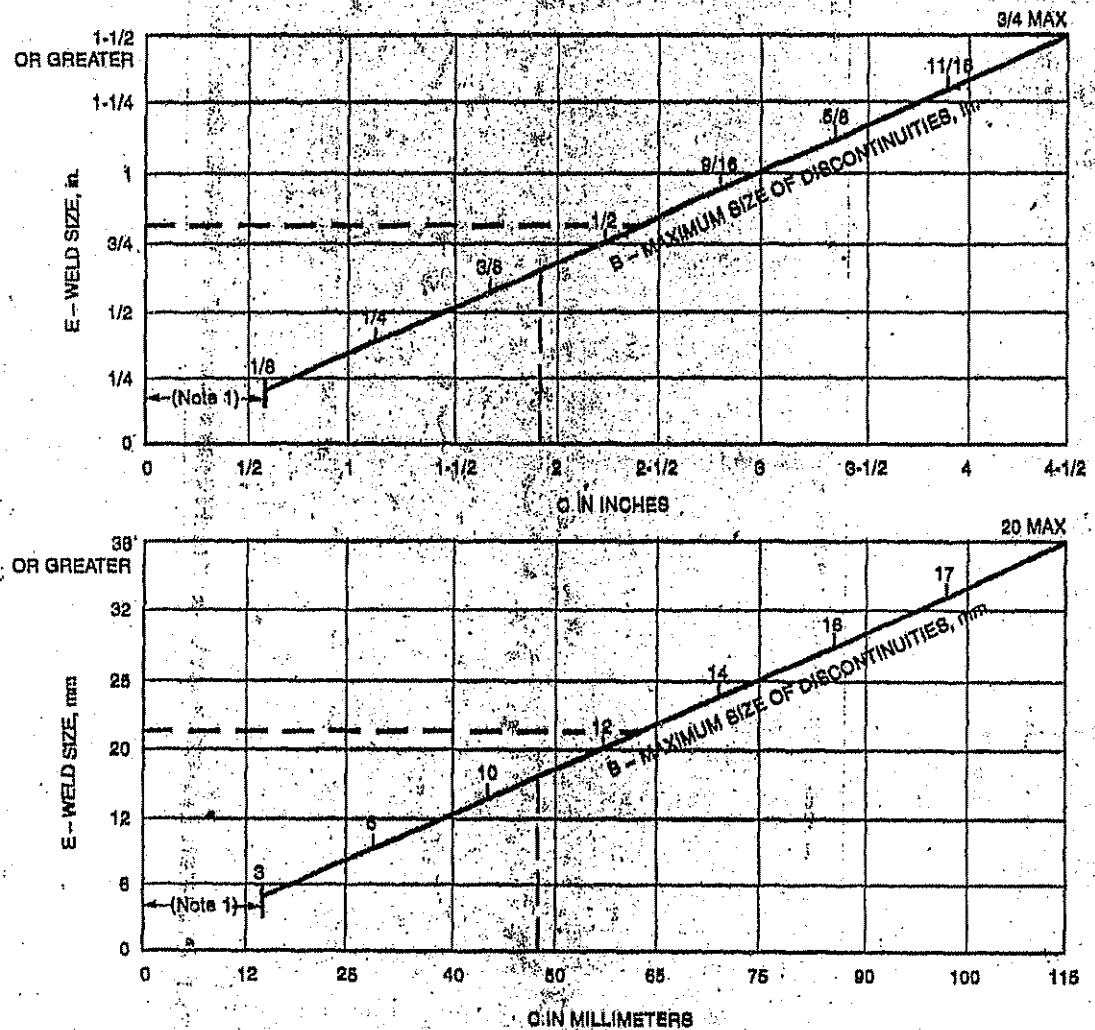

General Notes:

- To determine the maximum size of discontinuity allowed in any joint or weld size, project E horizontally to B.
- To determine the minimum clearance allowed between edges of discontinuities of any size, project B vertically to C.
- See Legend on page 225 for definitions.

Note:

1. The maximum size of a discontinuity located within this distance from an edge of plate shall be 1/8 in. [3 mm], but a 1/8 in. [3 mm] discontinuity shall be 1/4 in. [6 mm] or more away from the edge. The sum of discontinuities less than 1/8 in. [3 mm] in size and located within this distance from the edge shall not exceed 3/16 in. [5 mm]. Discontinuities 1/16 in. [2 mm] to less than 1/8 in. [3 mm] shall not be restricted in other locations unless they are separated by less than 2L (L being the length of the larger discontinuity); in which case, the discontinuities shall be measured as one length equal to the total length of the discontinuities and space and evaluated as shown in Figure 6.5.

Figure I — Weld Quality Requirements for Discontinuities Occurring in Cyclically Loaded Nontubular Compression Welds (Limitations of Porosity or Fusion-Type Discontinuities)

FIGURE II

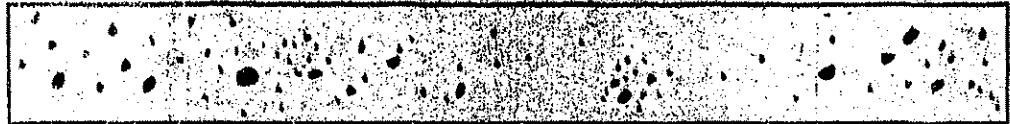

(a) Random Rounded Indications [See Note (1)]

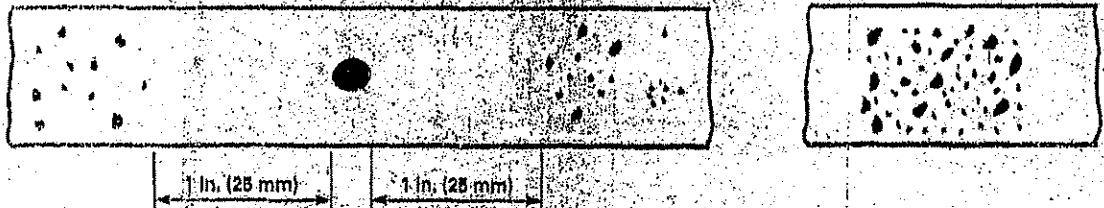

(b) Isolated Indication [See Note (2)]

(c) Cluster

NOTES:

- (1) Typical concentration and size permitted in any 6-in. (152 mm) length of weld.
- (2) Maximum size per Table 4-1.

FIG. 4-5 CHARTS FOR t OVER $\frac{3}{8}$ in. to $\frac{3}{4}$ in., INCLUSIVE



BHARAT HEAVY ELECTRICALS LIMITED
 BAP RANIPET - 632 406
 NON-DESTRUCTIVE TESTING
RADIOGRAPHIC EXAMINATION

R49-718/A

REPORT NO	:	REQ DATE :
REF NUM	:	BAY :
WORK ORDER	:	DU :
CUSTOMER	:	
PART NAME	:	QTY :
PART NUM	:	REV :
DRAWING NUMBER	:	THICKNESS :
MATL SPECIFICATION	:	TYPE OF JOINT :
WELD PROCESS	:	
WELDER NAME	:	
	:	
SURFACE CONDITION	:	CHP :
QP NUMBER	:	
REMARKS	:	
	:	
QC INSPECTOR NAME	:	
DATE OF TEST	:	
PROCEDURE REFERENCE	:	SIZE :
SOURCE & STRENGHT	:	FILM USED :
TECHNIQUE	:	SFD :
EXP TIME	:	CAMERA NO :
LEAD SCREEN (FRONT & BACK)	:	RADIOGRAPH NO :
FILM DENSITY	:	
IQI / SENSITIVITY	:	

RT READINGS

SL	LOCATION	FILM SIZE	SEGMENT NO	FINDINGS	REMARKS
1					
2					
3					
4					
5					

TEST STATUS : ACCEPTED

(LEVEL II) OPERATOR NAME & LEVEL	ASNT LEVEL-II PT, MT, RT, UT BHEL/BAP - RANIPET APPROVED BY NDT	EXTERNAL INS
---	---	--------------

BHEL
RANIPET

BHARAT HEAVY ELECTRICALS LTD.
BOILER AUXILIARIES PLANT
RANIPET 632 406

PR:QA:500
PAGE 01 OF 05

QUALITY DEPARTMENT

PROCEDURE FOR

ALLOWABLE DEVIATIONS FOR
DIMENSIONS WITHOUT SPECI-
FIED TOLERANCES

EFFECTIVE DATE

16/01/93

	NAME	SIGNATURE	DATE
PREPARED BY	K NITHIANANDAM	<i>K. Nithianandam</i>	16/1/93
REVIEWED BY	S ANIL KUMAR	<i>S. Anil Kumar</i>	16/1/93
APPROVED BY	P H TAMBAKHE	<i>P. H. Tambakhe</i>	16/1/93

ISSUED BY

: QUALITY ASSURANCE

REVISION

: NIL

DATE

:

DOCUMENT CONTROL NO:

7

File Name :PHT.RSU

QUALITY DEPARTMENT

1. Table 1 given below indicates the permissible variation in Linear Dimension of fabricated and machined components. The coarse grade is to be followed for fabricated components and medium grade for machined components.
2. Table 2 given below indicates the permissible deviations for Radii & Chamfers for machined components.
3. Table 3 given below indicates the permissible deviations for Angular dimensions for machined components.
4. Table 4 given below indicates the conditions under which the deviations given in this standard are not applicable.
5. Special rulings may be stated for linear dimensions of welded structures consisting of several assemblies.
6. If closer tolerances than those given in this procedure are necessary, the same shall be indicated in the relevant drawings.

TABLE - 1

Degree of accuracy	Deviations in mm for the nominal size range in mm												
	0.5 * up to 3	Over 3 upto 6	Over 6 upto 30	Over 30 upto 120	Over 120 upto 400	Over 400 upto 1000	Over 1000 upto 2000	Over 2000 upto 4000	Over 4000 upto 8000	Over 8000 upto 12000	Over 12000 upto 16000	Over 16000 upto 20000	
f (fine)	± 0.05	± 0.05	± 0.1	± 0.15	± 0.2	± 0.3	± 0.5	± 0.8	-	-	-	-	
n (medium)	± 0.1	± 0.1	± 0.2	± 0.3	± 0.5	± 0.8	± 1.0	± 2	± 3	± 4	± 5	± 6	
g (coarse)	± 0.15	± 0.2	± 0.5	± 0.8	± 1.2	± 2	± 3	± 4	± 5	± 6	± 7	± 8	
sg (very coarse)	-	± 0.5	± 1	± 1.5	± 2	± 3	± 4	± 6	± 8	± 10	± 12	± 12	

* In the case of nominal sizes below 0.5 mm, the deviations must be specified directly by the side of the nominal size.

TABLE - 2

DEVIATIONS FOR RADII & CHAMFERS

All dimensions are in mm

CLASS OF DEVIATION	RANGE OF NOMINAL DIMENSIONS					
	Above	0.5	3	6	30	120
Fine & Medium	Upto and Including	3	6	30	120	315
		± 0.2	± 0.5	± 1	± 2	± 4

TABLE - 3

DEVIATIONS FOR ANGULAR DIMENSIONS

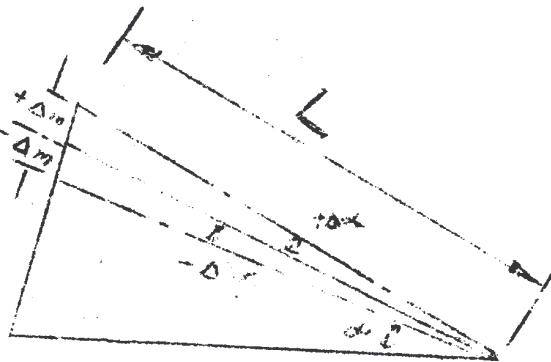

$\Delta\alpha$ =Angle Tolerance
in angular units
 Δm =Angle Tolerance
in linear units

All Dimensions are in mm

CLASS OF DEVIATIONS	Length (L) of shorter side of angle in mm							
	Above	-	10	50	120	500	800	1250
	Upto & including	10	50	120	500	800	1250	2000
FINE AND MEDIUM	Δm (mm)	± 0.1	± 0.2	± 0.6	± 0.8	± 0.96	± 1.125	± 1.5
	$\Delta\alpha$ (deg or min)	$\pm 1^\circ$	$\pm 30'$	$\pm 20'$	$\pm 10'$	$\pm 4'$	$\pm 3'$	$\pm 2'3''$

TABLE - 4
NON APPLICABILITY OF THE STANDARD

STANDARD SPECIFICATION	CONDITIONS FOR TOLERANCING	DIMENSIONS	PRODUCTION METHOD	SPECIAL AGREEMENTS
<p>Where Permissible deviations have been specified</p>	<p>Where higher values than those specified in Table 1 and 2 may be allowed.</p>	<p>For dimensions required to give a certain class of it</p>	<p>Casting, forging, pressing, rolling, welding, flame cutting</p>	<p>Where variations from this standard are agreed upon between the purchaser and the manufacturer</p>
	<p>Where only positive or only negative deviations are desired</p>	<p>For dimensions resulting after assembly</p>		
	<p>Where parts are manufactured separately and are required to be assembled together without any further treatment (selective assembly, spare parts etc)</p>	<p>Where concentricity between parts is required</p>		
		<p>For angular dimensions of a circular division (For example, angular positioning of teeth of clutches)</p>		
		<p>For angular dimensions in precision taps and in pipe bends</p>		
	<p>For dimensions of welded assemblies (unless the part is to be machined)</p>			



MASTER

BHEL: BAP:RANIPET
QUALITY DEPARTMENT

PR : QA :505
REV . NO . 01
DATE . 14 .07 .93
PAGE 01 OF 05

PROCEDURE FOR STORAGE OF SHELF LIFE ITEMS LIKE RUST
PREVENTIVE FLUIDS, PAINTS, RUBBER COMPONENTS,
GREASE AND ANTISEIZE COMPOUNDS AND SIMILAR
COMPONENTS / ITEMS.

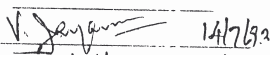
EFFECTIVE DATE : 14 . 07 . 93

	Name	Signature with date
Prepared by	V JAYRAMAN	 14/7/93
Reviewed by	P H TAMBAKHE	 14/7/93
Approved by	R N MISRA	 14/7/93

ISSUED BY : SM / QUALITY ASSURANCE

CONTROLLED COPY NO | |

INFORMATION COPY | |

BHEL : BAP : RANIPET
QUALITY DEPARTMENT

PR : QA : 505
REV . NO . 01
DATE . 14 . 07 . 93
PAGE 02 OF 05

Record of Revisions

Sl no	Revision carried out	Reason
01	S1 nos 1, 5, 7, 9 & 10 the method of storage revised.	-----

PROCEDURE FOR STORAGE OF LOW SHELF LIFE ITEMS LIKE

ANTI SEIZE / THREAD COATING COMPOUNDS , GREASES , PAINTS ,

RUST PREVENTIVE FLUIDS, RUBBER COMPONENTS

1.0 SCOPE:

This procedure spells out the method of storage of low shelf life items like antisize/thread coating compounds , greases , paints , rust preventive fluids and rubber compounds .

2.0 STORAGE

Please See the table . 1 . The method of storage of low shelf items is given in the table .

TABLE 1

S.No.	Description	Category	Method of storage	Items covered under the category .
01	Anti Seize compound/greases	L	Indoor storage in closed containers well ventilated and dry rooms , away from heat sources sunshine , flames , gas cylinders .	Thread Coating compounds , greases , molysulf lubricants etc.
02	Sealing Compounds	L	Indoor storage closed containers well ventilated and dry rooms , away from heat sources sunshine , flames , gas cylinders / solvents etc . If containers are damaged, reject the item	All sealing compounds

03	Rust preventive fluids (film forming type)	RPF	Outdoor, undershade Dry condition away from 1)Flame heat 2) Sunshine, 3)Gas cylinders, 4)Petrol Diesel, Kerosene other solvents 5) Near Fire extinguishing equipment .	Collecting Electrode rust preventive fluids, candopeel, strippable Coating.
04	Rust preventive fluids (non film forming type)	RPN	- DO -	APH heating element rust preventive fluids .
05	Natural Rubber Solvents, alkalis ,	RB	Indoor storage well ventilated dry rooms with paper and chalk powder wrapings, Away from oils, acids and flames , sunshine , weld heat.	Gaskets ,washers, forms, shapes, tubes pipes , conduits etc. .
06	Synthetic Rubber	RS	- DO -	- DO -
07	Red Oxide Zinc Chrome paints IS 2074	PR	In sealed containers indoors: In dry and well ventilated rooms Away from heat & flame , gas cylinders, flammable materials like Petrol , Diesel ,Kerosene etc .	- DO -
08	IS 2932 Synthetic enamel paints		- DO -	All Colors shades .

09 . Epoxy Paints	PEPX	In sealed containers. Indoor Dry condition . On separate racks ; Away from heat , flammable materials like Petrol , Diesel Kerosene , solvents .	This category includes Inorganic Zinc Rich paints also .
-------------------	------	--	--

10 . Chlorinated rubber paints .	PCLR	In sealed containers. Cool Dry place . Indoor only. Away from flame , heat, flammable materials like petrol , Diesel kerosene.
-------------------------------------	------	---

D: PRQA

BHEL
RANIPET
QUALITY DEPARTMENT

PR :QA:509

PAGE 01 OF 02

GUIDELINES FOR

NDT REQUIREMENTS ON
GAS CUT EDGES

EFFECTIVE DATE

04-08-93

PREPARED BY

B SRINIVASA RAO



REVIEWED BY

P.H.TAMBAKHE



APPROVED BY

R N MISTRA



ISSUED BY: QUALITY ASSURANCE

REV. NO.:00

CONTROL NO

1.0 SCOPE :

The procedure specifies the items for which for which Magnetic Particle Testing shall be conducted on gas cut edges.

2.0 PREFERENCE:

Sheet 7 of 12 of CE spec .M&P spec No.: 5.11.1.1.(s) dated 05-11-84 and review with SM/QA

3.0 GENERAL :

All gas cut edges which are machined later need not be examined by MT (Magnetic Particle Testing)

3.1 Plates above 38.1 mm for the items specified below shall only be tested. Stiffeners need not be non-destructively tested.

3.1 A FANS: Center plate , AP fan impeller hub flanges. Flanges for Conical cover plate, Flange for AP fan cover plate ,Impeller rings made of plate ,Conical cover plate seating rings.

3.1 A APH: Lug plates of lug assembly ,Rotor post header plates.

3.1 C ESP/Structural items: plates used as flanges for floor beams and those structural items for which NDT requirements are specified in other transmittals like QPS, Letters etc.



4.0 Reference standard and acceptance norm for MT shall be as per BHE :NDT:RP:MT:01/ latest revision.

BHEL::BAP::RANIPET
QUALITY DEPARTMENT

PR:QA:512
REV:00
Dt:31.1.94
Page 01 OF 04

PROCEDURE FOR CONTROL OF SURFACE PREPARATION AND
PAINTING OF FABRICATED COMPONENTS
AT SUB-CONTRACTORS WORKS.

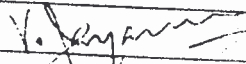
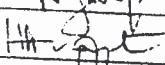
EFFECTIVE DATE 31.1.94

	NAME	SIGNATURE & DATE
PREPARED BY	V JAYARAMAN	
REVIEWED BY	H ANANTHANARAYAN	
APPROVED BY	R V MISRA	

ISSUED BY QUALITY ASSURANCE

CONTROL COPY NUMBER

MASTER COPY

PROCEDURE FOR CONTROL OF SURFACE PREPARATION AND PAINTING OF
FABRICATED COMPONENTS AT SUB-CONTRACTORS WORKS.

1.0 SCOPE:

1.1 This procedure details out the requirement for surface preparation and painting of all fabricated components at sub-contractors works.

1.1.1 Surface preparation equipment:

The sub-contractor should have the minimum surface preparation equipment as mentioned below:

- a) Wire brush
- b) Emery sheets of rough type
- c) Power wire brush to be used with pneumatic or electrical motors
- d) Brush for cleaning the dust removed by wire brushing power tool cleaning

1.2 Whenever any special requirement for surface preparation and painting are required, the same shall be indicated in the drawing or shall be informed separately to sub-contractors.

1.3 This PRQA is in line with the requirement of Painting Schedule RP 0674199.

2.0 SURFACE PREPARATION:

2.1 CLEANING OF OIL, GREASE ETC

2.1.1 The entire outer surface of the fabricated components shall be thoroughly cleaned using mineral turpentine, wire wheel, grinding wheel to make it free from OIL, GREASE, RUST, MILL SCALES and weld spatters.

2.2 METHOD OF RUST REMOVAL

2.2.1 Wire brush, emery sheets of rough type, Power /rotary wire wheel may be used for removing the dust, rust and mill scales from the surface.

2.2.2 The "Rustkil" (rust remover/converter) shall be applied whenever the rust cannot be removed by using power tool cleaning.

2.2.3 Only after clearance of surface preparation by BHEL Inspection/BHEL Authorised Inspection Agencies the sub-contractor can proceed with painting.

0 PAINTING

1 Only paints from BHEL approved suppliers shall be applied.

2 After visual inspection and clearance by QC BHEL/Authorised Inspection Agency one coat of red oxide Zinc chrome primer as per IS 2074 shall be applied by brushing to a dry film thickness of approx 25 microns.

3 The paint shall be allowed to hard dry and thoroughly before applying the second coat. Second coat shall be applied only after 18 hours.

4 A second coat of IS 2932 Synthetic Enamel smoke grey paint shall be applied over the primer to a coating thickness of 20 microns approximately.

5 The small items shall be dipped in the paint tank.

The final inspection of the component shall be offered to QC BHEL/Authorised Inspection Agency only after hard drying of the enamel paint and stencilling of work order No, D.U.No, details".

All edge prepared areas for welding at shop/site at later stage shall be applied with one coat of weldable primer.

Any scratches and soil sticking on the surfaces during handling shall be repaired before despatch to BHEL/Shipping.

K. Chandra
20

RECORDS:

The firm shall record the make/brand name and batch number of the approved paint used in the dimension report.

1. The sub-contractors shall maintain records of the primer paints procured, the source of the primer paints namely dealer, the manufacturer of the primer paints, the batch number of the primer paints and the delivery chalan reference for the paint procured along with the quantity and also copy of the test certificates certifying the quality of the paint. These records shall be verified by BHEL inspector immediately on procurement of the paint by sub-contractor and shall be countersigned by BHEL inspector. This record is subject to audit by Quality Assurance.

4.2 The firm shall show the details/evidence for procurement of approved paints to QC personnel (BHEL)/Authorised Inspection Agency whenever required during surveillance checks/audits. The sub-contractor before use of primer paints shall verify the correctness of specification of the primer paints before opening the drums. The drum shall be rolled roughly 20 times before opening the seal and stirring the contents. The contents shall be thoroughly stirred using a steel rod and shall be checked for any settling of pigment. If any pigment settlement is observed the process of resealing, rolling, stirring thereby redispersal of the paint pigment into the medium is to be ensured. Now a small quantity can be transferred to painting cans and applied by neat brushes of width atleast 3 inches.

4.3 The sub contractor shall ensure that the required number of primer coats are given on the components as per the painting schedule RP 0674199. Visual inspection shall be done for checking damages, poor paints, improper finish. After the paint films dry the inspector will randomly check the coating thickness with coating thickness gauge for the correctness of the thickness of the paint in case of any doubt.

5.0 TESTING OF PAINT SAMPLES

5.1 QC BHEL personnel shall collect random samples of paint (approx 1 litre) and submit the same to Quality Assurance for testing. Such random samples may be collected whenever any doubt arises about the quality of paint while carrying out visual inspection. Alternately QC/OLI may scrape dried paint film from painted surfaces for testing at paint test lab.

5.2 In case any batch of paint is found not conforming to requirement, the concerned brand of paint shall be removed from the approved list of paint suppliers of BAP, Ranipet.



**PROCEDURE FOR SURFACE PREPARATION
& PAINTING**

Doc no	PRQA:590
Rev.	02
Date	24.01.2018
Page no	1 of 54

PROCEDURE FOR SURFACE PREPARATION AND PAINTING

PREPARED BY

DEPARTMENT	NAME & DESIGNATION S/Shri	SIGNATURE
QA	Rajamanickam. M Sr.Engr/ QA	

REVIEWED BY

DEPARTMENT	NAME & DESIGNATION S/Shri	SIGNATURE
ENGINEERING	S.S. Mani AGM/ Engg	
QUALITY ASSURANCE	R. Aruchachalam DGM/ QA& QC-OLI	 24/1/18

APPROVED AND ISSUED BY

DEPARTMENT	NAME & DESIGNATION S/Shri	SIGNATURE
QUALITY	B. Srinivasa Rao AGM/ Quality	 9/2/18

	PROCEDURE FOR SURFACE PREPARATION & PAINTING	Doc no	PRQA:590
		Rev.	02
		Date	24.01.2018
		Page no	2 of 54

Record of Revision

Rev. No	Effective Date	Details of Revision
00	10.10.2002	RP0674199 Rev 05 requirements and PRQA rev 12 requirements were fully reviewed and this document is released as Rev 00 taking care of painting requirements of BAP projects. For project specific painting schemes respective CIS or contract specific painting schemes to be referred
01	22.05.2007	Painting requirement are fully reviewed. Red oxide Zinc chromate for primer application (IS 2074) is corrected as Red oxide Zinc phosphate primer (IS 12744) and also number of coats & DFT corrected
02	24.01.2018	Painting requirement are fully reviewed and totally revamped. Specific painting scheme for different environments are envisaged and other details added for overall painting document.

	PROCEDURE FOR SURFACE PREPARATION & PAINTING	Doc no	PRQA:590
		Rev.	02
		Date	24.01.2018
		Page no	3 of 54

1.0 SCOPE

- 1.1 This procedure specifies the requirements for surface preparation, application of primer, intermediate and finish paints, personnel qualification, testing, inspection of manufactured and sub contracted components of APH, Fans, ESP, Gates and Dampers and Chimney. (For desalination, please refer PRQA:526/ Latest respectively)
- 1.2 As these standard painting schemes have evolved well over the years, and the performance of these paint systems have been satisfactory in many sites, these schemes will be offered to the customers during the tender stage. The use of standard painting scheme has several advantages including the avoidance of certain time consuming surface preparations and also the use of the proven techno-economic options for painting of the products.
- 1.3 In case of special contract requirements, wherein the customer is specific about having a painting scheme different from the above, then those special contractual requirements will be addressed through a Contract Specific Document with customer approval, when required. The linkage will be provided in the CQR issued by QA.
- 1.4 Good preservation/ transportation enhances the life of painted products. Suitable lasing method (use of rubber, nylon, rope/bel) shall be used while transporting and avoid metal slings to tie up the product with the load carrier.

2.0 GENERAL

- 2.1 This procedure specifies the painting requirements to
- Provide adequate surface protection of components under prescribed storage conditions at Shop/ Site.
 - Temporary protection for components coming under the flue gas path till they are erected and
 - Protection for a reasonable time till completion of erection for components continuously exposed to atmospheric environment.
- 2.2 The scheme is based on the site practice of need based touch-up/ re-preservation program based on the duration of storage and the condition.
- 2.3 No painting shall be applied on the stainless steel, galvanized and any plated surfaces. For estimation of requirements of painting, the approximate area of coverage on non-absorbing surface is as given below,

	PROCEDURE FOR SURFACE PREPARATION & PAINTING	Doc no	PRQA:590
		Rev.	02
		Date	24.01.2018
		Page no	4 of 54

SL NO	Generic nature of paint	Theoretical covering area (Sq.m/ litre)	DFT/ Coat (Min)	Shade
01	Red oxide zinc phosphate primer to IS 12744	10	30	Red oxide
02	Synthetic enamel paint to IS 2932	10	20	Smoke grey
03	Heat resistant aluminum paint to IS 13183	10	20	Aluminum

2.4 For bought-out items, the painting scheme shall be specified in Engineering Drawing/ purchase Specification. Wherever it is not specified, the following is the minimum requirement,

- a) Primer: Two coats of red oxide Zinc phosphate primer to IS 12744- DFT 30 microns
- b) Finish: Two coats of synthetic enamel to IS 2932 smoke grey shade no:692 of IS: 5. DFT 20 microns per coat

Manufactured items for bough-out items shall be as per the painting scheme of the applicable PGMA in this document.

2.5 All currently active PGMA's are covered. Requirements for Missing/ new PGMA's can be obtained from Engineering and Quality Assurance department.

3.0 PAINTING SCHEME & REFERENCE ANNEXURES

3.1 The surface preparation, primer coat, intermediate coat and finish coat requirements for various painting schemes are given as part of this document.

3.2 Section I deals with the surface preparation schedule and section II deals with painting and coating.

3.3 Standard painting scheme for normal environment/ coastal (or) refinery (or) chemical environment/ export projects can be referred in Part- I/ II / III in Section II available with this document.

3.4 Annexure I shall be referred for notes on painting scheme furnished in this document. Necessary instructions given for protective coating of various components.

3.5 Inspection and testing plan on surface preparation and painting is given under Annexure II. Description given for various grade of surface cleanliness and inspection techniques.

3.6 Procedure for painter qualification given under Annexure III.

	PROCEDURE FOR SURFACE PREPARATION & PAINTING	Doc no	PRQA:590
		Rev.	02
		Date	24.01.2018
		Page no	5 of 54

- 3.7 The paints envisaged as per this document are indicated in this document under the Annexure IV- Painting scheme details for procurement and application purposes.
- 3.8 Good painting practices, which will be of assistance to task performer, have been detailed in Annexure VI.

	PROCEDURE FOR SURFACE PREPARATION & PAINTING	Doc no	PRQA:590
		Rev.	02
		Date	24.01.2018
		Page no	6 of 54

SECTION - I

4.0 SURFACE PREPARATION REQUIREMENTS FOR PAINTING AND COATING

- 4.1 The effectiveness and duration of the protection provided by organic, Inorganic and metallic coatings for corrosion protection depends among other things decisively on proper surface preparation. This section deals with the methods of surface preparation, their effectiveness and fields of application.
- 4.2 This section is largely based on ISO 8501-1; 1988 that in turn is based on the Swedish standard SS 05 59 00.

4.3 SURFACE PREPARATION METHODS

- 4.3.1 Surface preparation depends on the initial condition of uncoated surfaces. The details of rust level, rust removal methods and characteristics surfaces are given in Table 1.0.

4.4 DEFINITIONS AND METHODS OF CLEANING

4.5 CLEANLINES OF SURFACES

- 4.5.1 Cleaning requirement and levels of cleanliness, contaminants such as dirt, oil that will interfere with the adhesion or effectiveness of the proposed coating must be removed. Coats of materials related to the metal (scale, rust) and coats of different materials (e.g existing coating) should be removed until the agreed level of cleanliness is attained.
- 4.5.2 Contaminants/ coats, both of related material and of materials different from the metal may be removed in one operation if the nature, level and thickness permits this. The required level of cleanliness depends on
- The corrosion protection system selected
 - The type of corrosion exposure expected
 - The initial condition of the surface being prepared
 - The possible rust removal method
 - Economic considerations
- 4.5.3 Generally, the standard levels of cleanliness as in table 1.0 should be used as basis. This does not cover the removal of weld spatter, weld or flame cutting slag or chips, repair grinding of rolling defects (laminations) deburring and similar operations.

	PROCEDURE FOR SURFACE PREPARATION & PAINTING	Doc no	PRQA:590
		Rev.	02
		Date	24.01.2018
		Page no	7 of 54

4.6 MECHANICAL METHODS OF REMOVING DUST

4.6.1 Manual rust removal:

4.6.1.1 This applies to standard levels of cleanliness St 2, St 3 as per table 1.0 manual cleaning uses wire brush, stripping knife, Swedish scraper, rust removing hammer etc., the method must not damage the metal being derusted. Subsequent cleaning by sweeping or brushing off or by blowing off with dry air.

4.6.2 Mechanical rust removal:

4.6.2.1 This applies to standard levels of cleanliness St2, St3 as per table 1.0 cleaning can be done by mechanically driven rust removing tools viz. rotating wire brush, impact piston devices or rotary descalers, sanding discs etc. The surface areas where the power driven tool cannot enter, manual cleaning should be done. The method must not damage the metal being derusted. Subsequent cleaning by sweeping or brushing off or blowing off with dry air.

4.6.3 Blast cleaning

4.6.3.1 This applies to standard levels of cleanliness Sa 1, Sa 2½, Sa 3 as per table 1.0. Chemically contaminated surfaces must be pre-washed. Surfaces having coarse rust must be pre-cleaned with impact tools prior to blast cleaning.

4.6.3.2 Compressed air blasting is generally recommended for our operations. It is freely directed air blasting in blasting cubicles, Rooms or sheds with re-circulation of blasting abrasives.

4.6.4 Removal of contaminants/ coat of material different from the metal

4.6.4.1 Surface of metal contaminated with cutting fluid (machine coolant) oil or grease shall be wiped with mineral turpentine/ tri-chloroethylene prior to applying any methods of mechanical surface preparation.

4.6.4.2 If any old paint film or rust preventive films are present they may be removed with paint removing jelly.

4.6.4.3 As far as possible the cleaning method should be so chosen that all the scale is removed from the metallic surface to be coated. For heavily scaled metallic surfaces either blasting or picking may be adopted over and above the requirements called for in the table 1.0

4.6.5 Notes to Table 1.0

4.6.5.1 Initial condition of uncoated surfaces (rust grade as per SS 05 59 00)

a) Steel surface largely covered with adhering mill scale but little, if any rust.

	PROCEDURE FOR SURFACE PREPARATION & PAINTING	Doc no	PRQA:590
		Rev.	02
		Date	24.01.2018
		Page no	8 of 54

- b) Steel surface, which begun to rust and from which the mill scale has begun to flake.
- c) Steel surface on which the mill scale has rusted away or from which it can be scrapped, but with slight pitting visible under normal vision.
- d) Steel surface on which the mill scale has rusted away and on which general pitting is visible under normal vision.

4.6.5.2 Standard levels of cleanliness equivalent to steel structures painting council of US (SSPC) also given in brackets in table 1.0.

Table 1.0

Standard levels of cleanliness	Rust removal method	Initial conditions of steel surfaces (Uncoated ref. 4.5)	Essential characteristics of the prepared steel surface
St 2 (SSPC- SP 2)	Thorough hand and power tool cleaning	B, C, D	When viewed without magnification, the surface shall be free from visible oil, grease and dirt and from poorly adhering mill scale, rust coatings and foreign matter.
St 3 (SSPC SP 3)	Very thorough hand and power tool cleaning	B, C, D	As for St 2, but the surface shall be treated much more thoroughly to give a metallic sheen arising from the metallic substrate.
Sa 1 (SSPC SP 7)	Light blast cleaning	B, C, D	When viewed without magnification, the surface shall be free from visible oil, grease and dirt and from poorly adhering mill scale, rust coatings and foreign matter.
Sa 2 (SSPC SP 6)	Thorough blast cleaning	B, C, D	When viewed without magnification, the surface shall be free from visible oil, grease and dirt and from most of the mill scale, rust, paint coatings and foreign matter. Any residual contamination shall be firmly adhering.

	PROCEDURE FOR SURFACE PREPARATION & PAINTING	Doc no	PRQA:590
		Rev.	02
		Date	24.01.2018
		Page no	9 of 54

Standard levels of cleanliness	Rust removal method	Initial conditions of steel surfaces (Uncoated ref. 4.5)	Essential characteristics of the prepared steel surface
Sa 2½ (SSPC SP 10)	Very thorough blast cleaning	B, C, D	When viewed without magnification, the surface shall be free from visible oil, grease and dirt and from the mill scale, rust, paint coatings and foreign matter. Any remaining traces of contaminations shall show only as slight stains in the form of spots or stripes.
Sa 3 (SSPC SP 5)	Blast cleaning to visually clean steel	A, B, C, D	When viewed without magnification, the surface shall be free from visible oil, grease and dirt and from the mill scale, rust, paint coatings and foreign matter. It shall have a uniform metallic colour.

 Ranipet	PROCEDURE FOR SURFACE PREPARATION & PAINTING	Doc no	PRQA:590
		Rev.	02
		Date	24.01.2018
		Page no	10 of 54

SECTION –II

PART- I

STANDARD PAINTING SCHEME FOR NORMAL ENVIRONMENT

SI no	PGMA/Description	Surface preparation & surface profile	Primer coat		Intermediate coat		Finish coat			Total DFT μ (min)
			Paint	No of coats/ DFT	Paint	No of coats	Paint	No of coats	Shade	
A	REGENERATIVE AIR PRE- HEATERS									
01	Heating element baskets (without elements) 52010, 024, 025	Power tool cleaning to ST- 3 (SSPC SP3)	Red oxide zinc phosphate primer (Alkyd base) to IS 12744	02/ DFT=30 μ / coat	--	--	--	--	--	60
02	Heating element baskets (with elements) 52010, 024, 025	--	Temporary rust preventive oil non dry type (*) (Dipping)	--	--	--	--	--	--	--
03	Rotor post assembly machined items of (52011), Pin rack assembly (52012), Seals (52013, 52054, 52055), sector plates (52041, 52042) and machined components of APH	--	Temporary rust preventive oil dry type (**)	40	--	--	--	--	--	40
04	Components in flue gas path and insulated Rotor post assy (52011), T bars (52013), Rotor housing assy (52030), Hot and cold connecting plate assy (52041,52042)	Commercial blast cleaning (Sa 2) (SSPC SP6)	Red oxide zinc phosphate primer (Alkyd base) to IS 12744	02/ DFT=30 μ / coat	--	--	--	--	--	60

(*) Specification as per PRQA 522/ Rev 00

(**) Specification as per PRQA 523/ Rev 00; For CE coil- TEP/AQCS/RP (Latest)



**PROCEDURE FOR SURFACE PREPARATION
& PAINTING**

Doc no	PRQA:590
Rev.	02
Date	24.01.2018
Page no	11 of 54

Part- I contd....

SI no	PGMA/Description	Surface preparation & surface profile	Primer coat		Intermediate coat		Finish coat			Total DFT μ (min)
			Paint	No of coats/ DFT	Paint	No of coats	Paint	No of coats	Shade	
05	Components exposed to atmosphere Rotor drive assy (52100), Access door (52220), Air seal piping (52211), observation port other than glass part (52220), Rotor stoppage alarm other than aluminium (52220), Loose items of air receiver (52220), Guide bearing assy (52261), Support bearing assy (52262), Oil piping GB, SB (52271, 52272), Oil circulation unit (52274), Deluge and wash pipe assy (52301, 52302), Cleaning device assy (52339, 52340), Thermocouple pipe assy other than SS	Commercial blast cleaning (Sa 2) (SSPC SP6)	Red oxide zinc phosphate primer (Alkyd base) to IS 12744	01/ DFT=30 μ / coat	--	--	Synthetic Enamel paint to IS 2932	02/ DFT= 20 μ / coat; Total 40 μ	Smoke grey Shade 692 of IS 5	70
B	TUBULAR AIR PRE-HEATER									
01	Side walls (external surfaces and internal surfaces)	Commercial blast cleaning (Sa 2) (SSPC SP6)	Red oxide zinc phosphate primer (Alkyd base) to IS 12744	02/ DFT=30 μ / coat	--	--	--	--	--	60

 Ranipet	PROCEDURE FOR SURFACE PREPARATION & PAINTING	Doc no	PRQA:590
		Rev.	02
		Date	24.01.2018
		Page no	12 of 54

Part- I contd....

SI no	PGMA/Description	Surface preparation & surface profile	Primer coat		Intermediate coat		Finish coat			Total DFT μ (min)
			Paint	No of coats/ DFT	Paint	No of coats	Paint	No of coats	Shade	
02	Machined surfaces, tubes of TAPH, tube plates and intermediate plates	--	Temporary rust preventive oil dry type (**)	40	--	--	--	--	--	40
C	FANS									
01	Foundation materials 550XX, 560XX (Threaded portion)	Power tool cleaning to St-3 (SSPC SP3)	Temporary rust preventive oil	40	--	--	--	--	--	--
				Other areas except threaded portion- Red oxide Zinc phosphate primer to IS 12744, DFT- 30 μ						
02	Components exposed to atmosphere									
02.a	Bearing pedestals, Base frame, servomotor assy, shaft with bearing assy, OGV, IGV (55-1XX, 55-2XX, 55-3XX, 55-5XX, 55-6XX, 56-4XX) Bearing pedestals, Base frame, shaft with bearing assy, RVC, IGV, Support for seal, shaft protecting tube, Spiral casing (if no insulation is applicable), Damper (56-1XX, 56-2XX, 56-3XX, 56-4XX) Coupling guard (56-8XX, 55-8XX), Tools (56-000, 55-000)	Commercial blast cleaning (Sa 2) (SSPC SP6)	Red oxide zinc phosphate primer (Alkyd base) to IS 12744	01/ DFT=30 μ / coat	--	--	Synthetic Enamel paint to IS 2932	02/ DFT= 20 μ / coat; Total 40 μ	Smoke grey Shade 692 of IS 5	70
<p style="text-align: center;">General notes for SI no: 02.a & 02.b for C. Fans</p> <ol style="list-style-type: none"> 1) As a assy, no blasting to be done for servomotor assy & shaft with bearing assy. 2) Before assy, all external un-machined surfaces of bearing housing/ cylinder to be painted. 3) AP impeller painting to be done before assembly except oil chamber area & mating component contact area. 4) After SR/ Before machining, blasting and primer painting to be done. 										
02.b	AP fan components like Servomotor assy, Shaft with bearing assy	Power tool cleaning to St-3 (SSPC SP3)	Epoxy based zinc phosphate primer to IS 13238	02/ DFT=30 μ / coat	--	--	--	--	--	60

	PROCEDURE FOR SURFACE PREPARATION & PAINTING	Doc no	PRQA:590
		Rev.	02
		Date	24.01.2018
		Page no	13 of 54

Part- I contd....

Sl no	PGMA/Description	Surface preparation & surface profile	Primer coat		Intermediate coat		Finish coat			Total DFT μ (min)
			Paint	No of coats/ DFT	Paint	No of coats	Paint	No of coats	Shade	
03	Components in Air/ Gas and under insulation									
03.a	Suction chamber, diffuser, housing, OGV, Spiral casing, damper, IG, RVC, impeller, shaft (56-1XX,56-2XX, 56-3XX, 56-4XX) Silencer (55-9XX, 56-9XX)	Commercial blast cleaning (Sa 2) (SSPC SP6)	Red oxide zinc phosphate primer (Alkyd base) to IS 12744	02/ DFT=30 μ / coat	--	--	--	--	--	60
03.b	AP fan impeller (55-2XX, 55-3XX)	Power tool cleaning to St-3 (SSPC SP3)	Epoxy based zinc phosphate primer to IS 13238	02/ DFT=30 μ / coat	--	--	--	--	--	60
04	Journal area of shaft (55-1XX, 56-1XX, 55-2XX, 56-2XX, 55-3XX, 56-3XX, 56-4XX)- Refer PRQA 341/ Latest									
05	All machined surfaces shall be applied with rust preventive.									
D	ELECTROSTATIC PRECIPITATOR									
01	GD drive arrangement (7X X10), Drive arrangement for emitting system (7X X17), Inspection doors (7X X23), Drive arrangement for CE rapping (7XX26), Outer roof (7X X42), ESP Penthouse other items (7XX55), ESP test equipment (7XX61), Water washing system (7X X66), Tools & Tackles (7X 996), Lifting beam (7X X20)	Commercial blast cleaning (Sa 2) (SSPC SP6)	Red oxide zinc phosphate primer (Alkyd base) to IS 12744	01/ DFT=30 μ / coat	--	--	Synthetic Enamel paint to IS 2932	02/ DFT= 20 μ / coat; Total 40 μ	Smoke grey Shade 692 of IS 5	70

	PROCEDURE FOR SURFACE PREPARATION & PAINTING	Doc no	PRQA:590
		Rev.	02
		Date	24.01.2018
		Page no	14 of 54

Part- I contd....

SI no	PGMA/Description	Surface preparation & surface profile	Primer coat		Intermediate coat		Finish coat			Total DFT μ (min)
			Paint	No of coats/ DFT	Paint	No of coats	Paint	No of coats	Shade	
02	ESP Penthouse columns & Trusses (7X-X55), ESP columns (7X X81), Hopper approach platform (7X X65)	Blast cleaning to near white metal Sa 2½ (SSPC SP10) Surface profile of 35-50 μ m	Epoxy based Zinc phosphate primer to IS 13238 (Latest)	01/ DFT= 30 μ m	Epoxy based MIO pigmented intermediate coat	01/ DFT= 75 μ m	Epoxy based polyamide cured finish paint to IS 14209 (Latest) + Aliphatic acrylic polyurethane paint to IS 13213 (Latest)	01/ DFT= 30 μ m	Smoke grey Shade 692 of IS 5	165
		Columns below 0.0 level- Chlorinated rubber based zinc phosphate primer to 50 μ m (min) to be applied.								
03	Stringer and guard plates (8X 610), Hand rails, post, step treads, Floor grills (8X 611,612,613)	Hot dip galvanizing to a coating weight of 610gm per sq. m (minimum) and to a coating thickness of 85 microns (minimum)								

SI no	PGMA/Description	Surface preparation & surface profile	Primer coat		Intermediate coat		Finish coat			Total DFT μ (min)
			Paint	No of coats/ DFT	Paint	No of coats	Paint	No of coats	Shade	
04	Insulator housing assy (7X X06), Gas distribution assy (7X X08), GD rapping mechanism (7X X09), Gas screening (7X X11), Emitting system suspension (7X X13), Emitting Electrode rapping (7X X16), Suspension arrangement for CE (7X X19), Frame of Emitting system Top, middle & bottom (7X	Commercial blast cleaning (Sa 2) (SSPC SP6)	Red oxide zinc phosphate primer (Alkyd base) to IS 12744	02/ DFT= 30 μ / coat	--	--	--	--	--	60



**PROCEDURE FOR SURFACE PREPARATION
& PAINTING**

Doc no	PRQA:590
Rev.	02
Date	24.01.2018
Page no	15 of 54

X21, X22, X32), shock bars(7X X24), CE rapping mechanism (7X X25), contd... Contd... Ridges (7X X43), Hopper upper, lower & middle part (7X X44, X45), Insulator support panel (7X X46), Roof panel assy (7X X47) Casing structure (7X X28, X48), Casing shell (7X X49, ESP funnel (7X X50), Splitter & Guide vane (7X X57)										
--	--	--	--	--	--	--	--	--	--	--

SI no	PGMA/Description	Surface preparation & surface profile	Primer coat		Intermediate coat		Finish coat			Total DFT μ (min)
			Paint	No of coats/ DFT	Paint	No of coats	Paint	No of coats	Shade	
05	EE (7X X15) (EE hook), EE suspension hook (7X X13), CE (7X X20), CE suspension hook (7X X19), Foundation material for ESP structures & ducts (7X X80)	--	Temporary rust preventive oil dry type (**)	40	--	--	--	--	--	40
E	GATES AND DAMPERS									
01	Gates and Damper Temperature $\leq 95^{\circ}\text{C}$ (57-0XX, 57-1XX)	Commercial blast cleaning (Sa 2) (SSPC SP6)	Red oxide zinc phosphate primer (Alkyd base) to IS 12744	01/ DFT= 30 μ / coat	--	--	Synthetic Enamel paint to IS 2932	02/ DFT= 20 μ / coat; Total 40 μ	Smoke grey Shade 692 of IS 5	70
02	Gates and Damper Temperature $\geq 95^{\circ}\text{C}$ (57-2XX, 57-3XX, 57-4XX, 57-6XX)	Commercial blast cleaning (Sa 2) (SSPC SP6)	Red oxide zinc phosphate primer (Alkyd base) to IS 12744	02/ DFT= 30 μ / coat	--	--	--	--	--	60



**PROCEDURE FOR SURFACE PREPARATION
& PAINTING**

Doc no	PRQA:590
Rev.	02
Date	24.01.2018
Page no	16 of 54

03	Gates blades, Machined components of G&D	--	Temporary rust preventive oil dry type (**)	40	--	--	--	--	--	40
SI no	PGMA/Description	Surface preparation & surface profile	Primer coat		Intermediate coat		Finish coat			Total DFT μ (min)
			Paint	No of coats/ DFT	Paint	No of coats	Paint	No of coats	Shade	
F	CHIMNEY									
01	Foundation bolt (87010)	Power tool cleaning to St-3 (SSPC SP3)	Temporary rust preventive oil dry type (**)	40	--	--	--	--	--	40
02	Shells- Inside and Uninsulated side, base plate (87 100)	Blast cleaning to near white metal Sa 2½ (SSPC SP10) Surface profile of 35-50 μ m	Heat resistant aluminium paint as per IS 13183 (Gr I- Upto 600°C, Gr II- 200°C to 400°C Gr. III- Upto 200°C)	02/ DFT= 20 μ / coat	--	--	--	--	--	40
03	Ducts uninsulated, Strakes, (87150), Painter trolley (87200)	Power tool cleaning to St-3 (SSPC SP3)	Heat resistant aluminium paint as per IS 13183 (Gr I- Upto 600°C, Gr II- 200°C to 400°C Gr. III- Upto 200°C)	02/ DFT= 20 μ / Coat	--	--	--	--	--	40
04	Shells- Outside insulated (87100), Ducts- Insulated (87150)	Blast cleaning to near white metal Sa 2½ (SSPC SP10) Surface profile of 35-50 μ m	Red oxide zinc phosphate primer (Alkyd base) to IS 12744	02/ DFT= 30 μ / coat	--	--	--	--	--	60
05	Ladders, Hand rails, Floor grills. Platforms (87300)	Commercial blast cleaning (Sa 2) (SSPC SP6)	Red oxide zinc phosphate primer (Alkyd base) to IS 12744	01/ DFT= 30 μ / coat	--	--	Synthetic Enamel paint to IS 2932	02/ DFT= 20 μ / coat; Total 40 μ	Smoke grey Shade 692 of IS 5	70

 Ranipet	PROCEDURE FOR SURFACE PREPARATION & PAINTING	Doc no	PRQA:590
		Rev.	02
		Date	24.01.2018
		Page no	17 of 54

SECTION –II

PART- II

STANDARD PAINTING SCHEME FOR COASTEL/ REFINERY ENVIRONMENT

SI no	PGMA/Description	Surface preparation & surface profile	Primer coat		Intermediate coat		Finish coat			Total DFT μ (min)
			Paint	No of coats/ DFT	Paint	No of coats	Paint	No of coats	Shade	
A REGENERATIVE AIR PRE- HEATERS										
01	Heating element baskets (without elements) 52010, 024, 025	Power tool cleaning to ST- 3 (SSPC SP3)	Red oxide zinc phosphate primer (Alkyd base) to IS 12744	02/ DFT=30 μ / coat	--	--	--	--	--	60
02	Heating element baskets (with elements) 52010, 024, 025	--	Temporary rust preventive oil non dry type (*) (Dipping)	--	--	--	--	--	--	--
03	Rotor post assembly machined items of (52011), Pin rack assembly (52012), Seals (52013, 52054, 52055), sector plates (52041, 52042) and machined components of APH	--	Temporary rust preventive oil dry type (**)	40	--	--	--	--	--	40
04	Components in flue gas path and insulated Rotor post assy (52011), T bars (52013), Rotor housing assy (52030), Hot and cold connecting plate assy (52041,52042)	Commercial blast cleaning (Sa 2) (SSPC SP6)	Red oxide zinc phosphate primer (Alkyd base) to IS 12744	02/ DFT=30 μ / coat	--	--	--	--	--	60

(*) Specification as per PRQA 522/ Rev 00

(**) Specification as per PRQA 523/ Rev 00; For CE coil- TEP/AQCS/RP (Latest)



**PROCEDURE FOR SURFACE PREPARATION
& PAINTING**

Doc no	PRQA:590
Rev.	02
Date	24.01.2018
Page no	18 of 54

SI no	PGMA/Description	Surface preparation & surface profile	Primer coat		Intermediate coat		Finish coat			Total DFT μ (min)
			Paint	No of coats/ DFT	Paint	No of coats	Paint	No of coats	Shade	
05	Components exposed to atmosphere Rotor drive assy (52100), Access door (52220), Air seal piping (52211), observation port other than glass part (52220), Rotor stoppage alarm other than aluminium (52220), Loose items of air receiver (52220), Guide bearing assy (52261), Support bearing assy (52262), Oil piping GB, SB (52271, 52272), Oil circulation unit (52274), Deluge and wash pipe assy (52301, 52302), Cleaning device assy (52339, 52340), Thermocouple pipe assy other than SS	Blast cleaning to near white metal Sa 2½ (SSPC SP10) Surface profile of 35-50 μ m	Inorganic Ethyl zinc silicate primer to IS 14946 (Latest)	01/ DFT= 75 μ m/ coat	Epoxy based MIO/TiO ₂ pigmented intermediate coat	01/ DFT= 75 μ m/ coat	Epoxy based polyamide cured finish paint to IS 14209 (Latest)	01/ DFT= 75 μ m/ coat	Smoke grey Shade 692 of IS 5	225
B	TUBULAR AIR PRE-HEATER									
01	Side walls (external surfaces and internal surfaces)	Commercial blast cleaning (Sa 2) (SSPC SP6)	Red oxide zinc phosphate primer (Alkyd base) to IS 12744	02/ DFT=30 μ / coat	--	--	--	--	--	60

Part- II contd....

 Ranipet	PROCEDURE FOR SURFACE PREPARATION & PAINTING	Doc no	PRQA:590
		Rev.	02
		Date	24.01.2018
		Page no	19 of 54

SI no	PGMA/Description	Surface preparation & surface profile	Primer coat		Intermediate coat		Finish coat			Total DFT μ (min)
			Paint	No of coats/ DFT	Paint	No of coats	Paint	No of coats	Shade	
02	Machined surfaces, tubes of TAPH, tube plates and intermediate plates	--	Temporary rust preventive oil dry type (**)	40	--	--	--	--	--	40
C	FANS									
01	Foundation materials 550XX, 560XX (Threaded portion)	Power tool cleaning to St-3 (SSPC SP3)	Temporary rust preventive oil	40	--	--	--	--	--	--
				Other areas except threaded portion- Red oxide Zinc phosphate primer to IS 12744, DFT- 30 μ						
02	Components exposed to atmosphere									
02.a	Bearing pedestals, Base frame, servomotor assy, shaft with bearing assy, OGV, IGV (55-1XX, 55-2XX, 55-3XX, 55-5XX, 55-6XX, 56-4XX) Bearing pedestals, Base frame, shaft with bearing assy, RVC, IGV, Support for seal, shaft protecting tube, Spiral casing (if no insulation is applicable), Damper (56-1XX, 56-2XX, 56-3XX, 56-4XX) Coupling guard (56-8XX, 55-8XX), Tools (56-000, 55-000)	Commercial blast cleaning (Sa 2) (SSPC SP6)	Red oxide zinc phosphate primer (Alkyd base) to IS 12744	01/ DFT=30 μ / coat	--	--	Synthetic Enamel paint to IS 2932	02/ DFT= 20 μ / coat; Total 40 μ	Smoke grey Shade 692 of IS 5	70
<p style="text-align: center;">General notes for SI no: 02.a & 02.b for C. Fans</p> <ol style="list-style-type: none"> 1) As a assy, no blasting to be done for servomotor assy& shaft with bearing assy. 2) Before assy, all external un-machined surfaces of bearing housing/ cylinder to be painted. 3) AP impeller painting to be done before assembly except oil chamber area & mating component contact area. 4) After SR/ Before machining, blasting and primer painting to be done. 										
02.b	AP fan components like Servomotor assy, Shaft with bearing assy	Power tool cleaning to St-3 (SSPC SP3)	Epoxy based zinc phosphate primer to IS 13238	02/ DFT=30 μ / coat	--	--	--	--	--	60

 Ranipet	PROCEDURE FOR SURFACE PREPARATION & PAINTING	Doc no	PRQA:590
		Rev.	02
		Date	24.01.2018
		Page no	20 of 54

Part- II contd....

Sl no	PGMA/Description	Surface preparation & surface profile	Primer coat		Intermediate coat		Finish coat			Total DFT μ (min)
			Paint	No of coats/ DFT	Paint	No of coats	Paint	No of coats	Shade	
03	Components in Air/ Gas and under insulation									
03.a	Suction chamber, diffuser, housing, OGV, Spiral casing, damper, IGV, RVC, impeller, shaft (56-1XX,56-2XX, 56-3XX, 56-4XX)	Commercial blast cleaning (Sa 2) (SSPC SP6)	Red oxide zinc phosphate primer (Alkyd base) to IS 12744	02/ DFT= 30 μ / coat	--	--	--	--	--	60
03.b	Silencer (55-9XX, 56-9XX)	Blast cleaning to near white metal Sa 2½ (SSPC SP10) Surface profile of 35-50 μ m	Inorganic Ethyl zinc silicate primer to IS 14946 (Latest)	01/ DFT= 75 μ m/ coat	Epoxy based MIO/TiO ₂ pigmented intermediate coat	01/ DFT = 75 μ m/ coat	Epoxy based polyamide cured finish paint to IS 14209 (Latest)	01/ DFT= 75 μ m / coat	Smoke grey Shade 692 of IS 5	225
03.c	AP fan impeller (55-2XX, 55-3XX)	Power tool cleaning to St-3 (SSPC SP3)	Epoxy based zinc phosphate primer to IS 13238	02/ DFT= 30 μ / coat	--	--	--	--	--	60
04	Journal area of shaft (55-1XX, 56-1XX, 55-2XX, 56-2XX, 55-3XX, 56-3XX, 56-4XX)- Refer PRQA 341/ Latest									
05	All machined surfaces shall be applied with rust preventive.									
D	ELECTROSTATIC PRECIPITATOR									
01	ESP Penthouse other items (7XX55), Water washing system (7X X66), Tools & Tackles (7X 996), Lifting beam (7X X20) Ridges (7X X43), Hopper upper, lower & middle part (7X X44, X45)	Commercial blast cleaning (Sa 2) (SSPC SP6)	Red oxide zinc phosphate primer (Alkyd base) to IS 12744	01/ DFT= 30 μ / coat	--	--	Synthetic Enamel paint to IS 2932	02/ DFT= 20 μ / coat; Total 40 μ	Smoke grey Shade 692 of IS 5	70

 Ranipet	PROCEDURE FOR SURFACE PREPARATION & PAINTING	Doc no	PRQA:590
		Rev.	02
		Date	24.01.2018
		Page no	21 of 54

Insulator support panel (7X X46), Roof panel assy (7X X47) contd... Contd... Casing structure (7X X28, X48), Casing shell (7X X49, ESP funnel (7X X50), Splitter & Guide vane (7X X57)										
--	--	--	--	--	--	--	--	--	--	--

SI no	PGMA/Description	Surface preparation & surface profile	Primer coat		Intermediate coat		Finish coat			Total DFT μ (min)
			Paint	No of coats/ DFT	Paint	No of coats	Paint	No of coats	Shade	
02	GD drive arrangement (7X X10), Drive arrangement for emitting system (7X X17), Inspection doors (7X X23), Drive arrangement for CE rapping (7XX26), Outer roof (7X X42)ESP Penthouse columns & Trusses (7X-X55), ESP columns (7X X81), ESP test equipment (7XX61), Hopper approach platform (7X X65),	Blast cleaning to near white metal Sa 2½ (SSPC SP10) Surface profile of 35-50 μ m	Inorganic Ethyl zinc silicate primer to IS 14946 (Latest)	01/ DFT= 30 μ m/ coat	Epoxy based MIO/TiO ₂ pigmented intermediate coat	01/ DFT= 75 μ m/ coat	Epoxy based polyamide cured finish paint to IS 14209 (Latest) + Aliphatic acrylic polyurethane paint to IS 13213 (Latest)	01/ DFT= 30 μ m/ coat	Smoke grey Shade 692 of IS 5	165
<div style="border: 1px solid black; padding: 5px; margin: 10px auto; width: 80%;"> ESP columns- Below 0.0 level- Two coats of primer as mentioned above shall be applied since this item will be embedded inside the concrete pedestal. </div>										
03	Stringer and guard plates (8X 610), Hand rails, post, step treads, Floor grills (8X 611,612,613),	Hot dip galvanizing to a coating weight of 610gm per sq. m (minimum) and to a coating thickness of 85 microns (minimum)								

Part- II contd....

 Ranipet	PROCEDURE FOR SURFACE PREPARATION & PAINTING	Doc no	PRQA:590
		Rev.	02
		Date	24.01.2018
		Page no	22 of 54

SI no	PGMA/Description	Surface preparation & surface profile	Primer coat		Intermediate coat		Finish coat			Total DFT μ (min)
			Paint	No of coats/ DFT	Paint	No of coats	Paint	No of coats	Shade	
04	Insulator housing assy (7X X06), Gas distribution assy (7X X08), GD rapping mechanism (7X X09), Gas screening (7X X11), Emitting system suspension (7X X13), Emitting Electrode rapping (7X X16), Suspension arrangement for CE (7X X19), Frame of Emitting system Top, middle& bottom (7X X21, X22, X32), shock bars(7X X24), CE rapping mechanism (7X X25)	Commercial blast cleaning (Sa 2) (SSPC SP6)	Red oxide zinc phosphate primer (Alkyd base) to IS 12744	02/ DFT= 30 μ / coat	--	--	--	--	--	60

SI no	PGMA/Description	Surface preparation & surface profile	Primer coat		Intermediate coat		Finish coat			Total DFT μ (min)
			Paint	No of coats/ DFT	Paint	No of coats	Paint	No of coats	Shade	
05	EE (7X X15) (EE hook), EE suspension hook (7X X13), CE (7X X20), CE suspension hook (7X X19), Foundation material for ESP structures & ducts (7X X80)	--	Temporary rust preventive oil dry type (**)	40	--	--	--	--	--	40
E	GATES AND DAMPERS									
01	Gates and Damper Temperature $\leq 95^{\circ}\text{C}$	Blast cleaning to	Inorganic Ethyl zinc	01/	--	--	Epoxy based	01/	Smoke grey	160



**PROCEDURE FOR SURFACE PREPARATION
& PAINTING**

Doc no	PRQA:590
Rev.	02
Date	24.01.2018
Page no	23 of 54

(57-0XX, 57-1XX)	near white metal Sa 2½ (SSPC SP10) Surface profile of 35-50µm	silicate primer to IS 14946 (Latest)	DFT= 80µm/ coat			polyamide cured finish paint to IS 14209 (Latest)	DFT= 80µm/ coat	Shade 692 of IS 5	
------------------	---	--------------------------------------	-----------------	--	--	---	-----------------	-------------------	--

SI no	PGMA/Description	Surface preparation & surface profile	Primer coat		Intermediate coat		Finish coat			Total DFT µ (min)
			Paint	No of coats/ DFT	Paint	No of coats	Paint	No of coats	Shade	
02	Gates and Damper Temperature > 95°C (57-2XX, 57-3XX, 57-4XX, 57-6XX)	Blast cleaning to near white metal Sa 2½ (SSPC SP10) Surface profile of 35-50µm	Inorganic Ethyl zinc silicate primer to IS 14946 (Latest)	01/ DFT= 80µm/ coat	--	--	Heat resistant aluminium paint as per IS 13183 (Gr I- Upto 600°C)	02/ DFT= 20µ/ coat	Aluminium	120
03	Gates blades, Machined components of G&D	--	Temporary rust preventive oil dry type (**)	40	--	--	--	--	--	40
F	CHIMNEY									
01	Foundation bolt (87010)	Power tool cleaning to St-3 (SSPC SP3)	Temporary rust preventive oil dry type (**)	40	--	--	--	--	--	40
02	Shells- Inside and Uninsulated side, base plate (87 100)	Blast cleaning to near white metal Sa 2½ (SSPC SP10) Surface profile of 35-50µm	Heat resistant aluminium paint as per IS 13183 (Gr I- Upto 600°C, Gr II- 200°C to 400°C Gr. III- Upto 200°C)	02/ DFT= 20µ/ coat	--	--	--	--	--	40
03	Ducts uninsulated, Strakes, (87150), Painter trolley (87200)	Blast cleaning to near white metal Sa 2½	Heat resistant aluminium paint as per IS 13183	02/ DFT= 20µ/ Coat	--	--	--	--	--	40



**PROCEDURE FOR SURFACE PREPARATION
& PAINTING**

Doc no	PRQA:590
Rev.	02
Date	24.01.2018
Page no	24 of 54

SI no	PGMA/Description	Surface preparation & surface profile	Primer coat		Intermediate coat		Finish coat			Total DFT μ (min)
			Paint	No of coats/DFT	Paint	No of coats	Paint	No of coats	Shade	
04	Shells- Outside insulated (87100), Ducts- Insulated (87150)	Blast cleaning to near white metal Sa 2½ (SSPC SP10) Surface profile of 35-50 μ m	Red oxide zinc phosphate primer (Alkyd base) to IS 12744	02/ DFT= 30 μ / coat	--	--	--	--	--	60
05	Ladders, Hand rails, Floor grills. Platforms (87300)	Hot dip galvanizing to a coating weight of 610gm per sq. m (minimum) and to a coating thickness of 85 microns (minimum)								

	PROCEDURE FOR SURFACE PREPARATION & PAINTING	Doc no	PRQA:590
		Rev.	02
		Date	24.01.2018
		Page no	25 of 54

SECTION –II

PART- III

STANDARD PAINTING SCHEME FOR EXPORT CONTRACTS

SI no	PGMA/Description	Surface preparation & surface profile	Primer coat		Intermediate coat		Finish coat			Total DFT μ (min)
			Paint	No of coats/ DFT	Paint	No of coats	Paint	No of coats	Shade	
A	REGENERATIVE AIR PRE- HEATERS									
01	Heating element baskets (without elements) 52010, 024, 025	Power tool cleaning to ST- 3 (SSPC SP3)	Red oxide zinc phosphate primer (Alkyd base) to IS 12744	02/ DFT=30 μ / coat	--	--	--	--	--	60
02	Heating element baskets (with elements) 52010, 024, 025	--	Temporary rust preventive oil non dry type (*) (Dipping)	--	--	--	--	--	--	--
03	Rotor post assembly machined items of (52011), Pin rack assembly (52012), Seals (52013, 52054, 52055), sector plates (52041, 52042) and machined components of APH	--	Temporary rust preventive oil dry type (**)	40	--	--	--	--	--	40
04	Components in flue gas path and insulated Rotor post assy (52011), T bars (52013), Rotor housing assy (52030), Hot and cold connecting plate assy (52041,52042)	Commercial blast cleaning (Sa 2) (SSPC SP6)	Red oxide zinc phosphate primer (Alkyd base) to IS 12744	02/ DFT=30 μ / coat	--	--	--	--	--	60

(*) Specification as per PRQA 522/ Rev 00 (**) Specification as per PRQA 524/ Rev 00 (Sea worthy rust preventive oil); CE coil- TEP/AQCS/RP (Latest)



**PROCEDURE FOR SURFACE PREPARATION
& PAINTING**

Doc no	PRQA:590
Rev.	02
Date	24.01.2018
Page no	26 of 54

SI no	PGMA/Description	Surface preparation & surface profile	Primer coat		Intermediate coat		Finish coat			Total DFT μ (min)
			Paint	No of coats/ DFT	Paint	No of coats	Paint	No of coats	Shade	
05	Components exposed to atmosphere Rotor drive assy (52100), Access door (52220), Air seal piping (52211), observation port other than glass part (52220), Rotor stoppage alarm other than aluminium (52220), Loose items of air receiver (52220), Guide bearing assy (52261), Support bearing assy (52262), Oil piping GB, SB (52271, 52272), Oil circulation unit (52274), Deluge and wash pipe assy (52301, 52302), Cleaning device assy (52339, 52340), Thermocouple pipe assy other than SS	Blast cleaning to near white metal Sa 2½ (SSPC SP10) Surface profile of 35-50 μ m	Inorganic Ethyl zinc silicate primer to IS 14946 (Latest)	01/ DFT= 75 μ m/ coat	Epoxy based MIO/TiO ₂ pigmented intermediate coat	01/ DFT= 75 μ m/ coat	Epoxy based polyamide cured finish paint to IS 14209 (Latest)	01/ DFT= 75 μ m/ coat	Smoke grey Shade 692 of IS 5	225
B	TUBULAR AIR PRE-HEATER									
01	Side walls (external surfaces and internal surfaces)	Commercial blast cleaning (Sa 2) (SSPC SP6)	Red oxide zinc phosphate primer (Alkyd base) to IS 12744	02/ DFT=30 μ / coat	--	--	--	--	--	60

Part- III contd....

 Ranipet	PROCEDURE FOR SURFACE PREPARATION & PAINTING	Doc no	PRQA:590
		Rev.	02
		Date	24.01.2018
		Page no	27 of 54

Sl no	PGMA/Description	Surface preparation & surface profile	Primer coat		Intermediate coat		Finish coat			Total DFT μ (min)
			Paint	No of coats/ DFT	Paint	No of coats	Paint	No of coats	Shade	
02	Machined surfaces, tubes of TAPH, tube plates and intermediate plates	--	Temporary rust preventive oil dry type (**)	40	--	--	--	--	--	40
C	FANS									
01	Foundation materials 550XX, 560XX (Threaded portion)	Power tool cleaning to St-3 (SSPC SP3)	Temporary rust preventive oil	40	--	--	--	--	--	--
				Other areas except threaded portion- Red oxide Zinc phosphate primer to IS 12744, DFT- 30 μ						
02	Components exposed to atmosphere									
02.a	Bearing pedestals, Base frame, servomotor assy, shaft with bearing assy, OGV, IGV (55-1XX, 55-2XX, 55-3XX, 55-5XX, 55-6XX, 56-4XX) Bearing pedestals, Base frame, shaft with bearing assy, RVC, IGV, Support for seal, shaft protecting tube, Spiral casing (if no insulation is applicable), Damper (56-1XX, 56-2XX, 56-3XX, 56-4XX) Coupling guard (56-8XX, 55-8XX), Tools (56-000, 55-000)	Blast cleaning to near white metal Sa 2½ (SSPC SP10) Surface profile of 35-50 μ m	Inorganic Ethyl zinc silicate primer to IS 14946 (Latest)	01/ DFT=80 μ / coat	--	--	Epoxy based polyamide cured finish paint to IS 14209 (Latest)	01/ DFT= 80 μ m/ coat	Smoke grey Shade 692 of IS 5	160
<p style="text-align: center;">General notes for Sl no: 02.a & 02.b for C. Fans</p> <ol style="list-style-type: none"> 5) As a assy, no blasting to be done for servomotor assy& shaft with bearing assy. 6) Before assy, all external un-machined surfaces of bearing housing/ cylinder to be painted. 7) AP impeller painting to be done before assembly except oil chamber area & mating component contact area. 8) After SR/ Before machining, blasting and primer painting to be done. 										
02.b	AP fan components like Servomotor assy, Shaft with bearing assy	Power tool cleaning to St-3 (SSPC SP3)	Epoxy based zinc phosphate primer to IS 13238	02/ DFT=30 μ / coat	--	--	--	--	--	60

Part- III contd....

 Ranipet	PROCEDURE FOR SURFACE PREPARATION & PAINTING	Doc no	PRQA:590
		Rev.	02
		Date	24.01.2018
		Page no	28 of 54

Sl no	PGMA/Description	Surface preparation & surface profile	Primer coat		Intermediate coat		Finish coat			Total DFT μ (min)
			Paint	No of coats/ DFT	Paint	No of coats	Paint	No of coats	Shade	
03	Components in Air/ Gas and under insulation									
03.a	Suction chamber, diffuser, housing, OGV, Spiral casing, damper, IGV, RVC, impeller, shaft (56-1XX, 56-2XX, 56-3XX, 56-4XX)	Commercial blast cleaning (Sa 2) (SSPC SP6)	Red oxide zinc phosphate primer (Alkyd base) to IS 12744	02/ DFT= 30 μ / coat	--	--	--	--	--	60
03.b	Silencer (55-9XX, 56-9XX)	Blast cleaning to near white metal Sa 2½ (SSPC SP10) Surface profile of 35-50 μ m	Inorganic Ethyl zinc silicate primer to IS 14946 (Latest)	01/ DFT= 75 μ m/ coat	Epoxy based MIO/TiO ₂ pigmented intermediate coat	01/ DFT = 75 μ m/ coat	Epoxy based polyamide cured finish paint to IS 14209 (Latest)	01/ DFT= 75 μ m / coat	Smoke grey Shade 692 of IS 5	225
03.c	AP fan impeller (55-2XX, 55-3XX)	Power tool cleaning to St-3 (SSPC SP3)	Epoxy based zinc phosphate primer to IS 13238	02/ DFT= 30 μ / coat	--	--	--	--	--	60
04	Journal area of shaft (55-1XX, 56-1XX, 55-2XX, 56-2XX, 55-3XX, 56-3XX, 56-4XX)- Refer PRQA 341/ Latest									
05	All machined surfaces shall be applied with rust preventive.									
D	ELECTROSTATIC PRECIPITATOR									
01	ESP Penthouse other items (7XX55), Water washing system (7X X66), Tools & Tackles (7X 996), Lifting beam (7X X20) Ridges (7X X43), Hopper upper, lower & middle part (7X X44, X45) Insulator support panel (7X X46),	Blast cleaning to near white metal Sa 2½ (SSPC SP10) Surface profile of 35-50 μ m	Red oxide zinc phosphate primer (Alkyd base) to IS 12744	02/ DFT= 30 μ / coat	--	--	Synthetic Enamel paint to IS 2932	02/ DFT= 20 μ / coat; Total 40 μ	Smoke grey Shade 692 of IS 5	100

 Ranipet	PROCEDURE FOR SURFACE PREPARATION & PAINTING	Doc no	PRQA:590
		Rev.	02
		Date	24.01.2018
		Page no	29 of 54

Roof panel assy (7X X47) contd... Contd... Casing structure (7X X28, X48), Casing shell (7X X49, ESP funnel (7X X50), Splitter & Guide vane (7X X57)										
---	--	--	--	--	--	--	--	--	--	--

Sl no	PGMA/Description	Surface preparation & surface profile	Primer coat		Intermediate coat		Finish coat			Total DFT μ (min)
			Paint	No of coats/ DFT	Paint	No of coats	Paint	No of coats	Shade	
02	GD drive arrangement (7X X10), Drive arrangement for emitting system (7X X17), Inspection doors (7X X23), Drive arrangement for CE rapping (7XX26), Outer roof (7X X42)ESP Penthouse columns & Trusses (7X-X55), ESP columns (7X X81), ESP test equipment (7XX61), Hopper approach platform (7X X65),	Blast cleaning to near white metal Sa 2½ (SSPC SP10) Surface profile of 35-50 μ m	Inorganic Ethyl zinc silicate primer to IS 14946 (Latest)	01/ DFT= 75 μ m/ coat	Epoxy based MIO/TiO ₂ pigmented intermediate coat	01/ DFT= 75 μ m/ coat	Epoxy based polyamide cured finish paint to IS 14209 (Latest) + Aliphatic acrylic polyurethane paint to IS 13213 (Latest)	02/ DFT= 35 μ m/ coat 01/ DFT= 30 μ m/ coat	Smoke grey Shade 692 of IS 5	250
<div style="border: 1px solid black; padding: 5px; width: fit-content; margin: 0 auto;"> ESP columns- Below 0.0 level- Two coats of primer as mentioned above shall be applied since this item will be embedded inside the concrete pedestal. </div>										
03	Stringer and guard plates (8X 610), Hand rails, post, step treads, Floor grills (8X 611,612,613),	Hot dip galvanizing to a coating weight of 610gm per sq. m (minimum) and to a coating thickness of 85 microns (minimum)								

Part- III contd....



**PROCEDURE FOR SURFACE PREPARATION
& PAINTING**

Doc no	PRQA:590
Rev.	02
Date	24.01.2018
Page no	30 of 54

SI no	PGMA/Description	Surface preparation & surface profile	Primer coat		Intermediate coat		Finish coat			Total DFT μ (min)
			Paint	No of coats/DFT	Paint	No of coats	Paint	No of coats	Shade	
04	Insulator housing assy (7X X06), Gas distribution assy (7X X08), GD rapping mechanism (7X X09), Gas screening (7X X11), Emitting system suspension (7X X13), Emitting Electrode rapping (7X X16), Suspension arrangement for CE (7X X19), Frame of Emitting system Top, middle & bottom (7X X21, X22, X32), shock bars (7X X24), CE rapping mechanism (7X X25)	Blast cleaning to near white metal Sa 2½ (SSPC SP10) Surface profile of 35-50 μ m	Red oxide zinc phosphate primer (Alkyd base) to IS 12744	02/ DFT= 30 μ / coat	--	--	--	--	--	60

SI no	PGMA/Description	Surface preparation & surface profile	Primer coat		Intermediate coat		Finish coat			Total DFT μ (min)
			Paint	No of coats/DFT	Paint	No of coats	Paint	No of coats	Shade	
05	EE (7X X15) (EE hook), EE suspension hook (7X X13), CE (7X X20), CE suspension hook (7X X19), Foundation material for ESP structures & ducts (7X X80)	--	Temporary rust preventive oil dry type (**)	40	--	--	--	--	--	40
E	GATES AND DAMPERS									
01	Gates and Damper Temperature $\leq 95^{\circ}\text{C}$ (57-0XX, 57-1XX)	Blast cleaning to near white metal Sa 2½	Inorganic Ethyl zinc silicate	01/ DFT= 80 μ m/ coat	--	--	Epoxy based polyamide cured	01/ DFT= 80 μ m/ coat	Smoke grey	160



**PROCEDURE FOR SURFACE PREPARATION
& PAINTING**

Doc no	PRQA:590
Rev.	02
Date	24.01.2018
Page no	31 of 54

		(SSPC SP10) Surface profile of 35-50µm	primer to IS 14946 (Latest)				finish paint to IS 14209 (Latest)		Shade 692 of IS 5	
--	--	--	-----------------------------	--	--	--	-----------------------------------	--	-------------------	--

SI no	PGMA/Description	Surface preparation & surface profile	Primer coat		Intermediate coat		Finish coat			Total DFT µ (min)
			Paint	No of coats/ DFT	Paint	No of coats	Paint	No of coats	Shade	
02	Gates and Damper Temperature > 95°C (57-2XX, 57-3XX, 57-4XX, 57-6XX)	Blast cleaning to near white metal Sa 2½ (SSPC SP10) Surface profile of 35-50µm	Inorganic Ethyl zinc silicate primer to IS 14946 (Latest)	01/ DFT= 80µm/ coat	--	--	Heat resistant aluminium paint as per IS 13183 (Gr I- Upto 600°C)	02/ DFT= 20µ/ coat	Aluminium	120
03	Gates blades, Machined components of G&D	--	Temporary rust preventive oil dry type (**)	40	--	--	--	--	--	40



**PROCEDURE FOR SURFACE PREPARATION
& PAINTING**

Doc no	PRQA:590
Rev.	02
Date	24.01.2018
Page no	32 of 54

Sl no	PGMA/Description	Surface preparation & surface profile	Primer coat		Intermediate coat		Finish coat			Total DFT μ (min)
			Paint	No of coats/DFT	Paint	No of coats	Paint	No of coats	Shade	
F	CHIMNEY									
01	Foundation bolt (87010)	Power tool cleaning to St-3 (SSPC SP3)	Temporary rust preventive oil dry type (**)	40	--	--	--	--	--	40
02	Shells- Inside and Uninsulated side, base plate (87 100)	Blast cleaning to near white metal Sa 2½ (SSPC SP10) Surface profile of 35-50 μ m	Inorganic Ethyl zinc silicate primer to IS 14946 (Latest)	01/ DFT= 80 μ m/ coat	--	--	Heat resistant aluminium paint as per IS 13183 (Gr I- Upto 600°C, Gr II- 200°C to 400°C Gr. III- Upto 200°C)	02/ DFT= 20 μ / coat	Aluminium	120
03	Ducts uninsulated, Strakes, (87150), Painter trolley (87200)	Blast cleaning to near white metal Sa 2½ (SSPC SP10) Surface profile of 35-50 μ m	Inorganic Ethyl zinc silicate primer to IS 14946 (Latest)	01/ DFT= 80 μ m/ coat	--	--	Heat resistant aluminium paint as per IS 13183 (Gr I- Upto 600°C, Gr II- 200°C to 400°C Gr. III- Upto 200°C)	02/ DFT= 20 μ / coat	Aluminium	120

Part- III contd....



**PROCEDURE FOR SURFACE PREPARATION
& PAINTING**

Doc no	PRQA:590
Rev.	02
Date	24.01.2018
Page no	33 of 54

SI no	PGMA/Description	Surface preparation & surface profile	Primer coat		Intermediate coat		Finish coat			Total DFT μ (min)
			Paint	No of coats/ DFT	Paint	No of coats	Paint	No of coats	Shade	
04	Shells- Outside insulated (87100), Ducts- Insulated (87150)	Blast cleaning to near white metal Sa 2½ (SSPC SP10) Surface profile of 35-50 μ m	Inorganic Ethyl zinc silicate primer to IS 14946 (Latest)	01/ DFT= 80 μ m/ coat	--	--	Heat resistant aluminium paint as per IS 13183 (Gr I- Upto 600°C, Gr II- 200°C to 400°C Gr. III- Upto 200°C)	02/ DFT= 20 μ / coat	Aluminium	120
05	Ladders, Hand rails, Floor grills. Platforms (87300)	Hot dip galvanizing to a coating weight of 610gm per sq. m (minimum) and to a coating thickness of 85 microns (minimum)								

	PROCEDURE FOR SURFACE PREPARATION & PAINTING	Doc no	PRQA:590
		Rev.	02
		Date	24.01.2018
		Page no	34 of 54

ANNEXURE I

NOTES FOR PAINTING SCHEME PART I, II& III

1. This painting scheme covers a comprehensive list of PGMAs being used in 125 to 800MW in an effort to standardize the painting scheme. Therefore, entire list of PGMAs will not be applicable for any specific project and only those PGMAs applicable for the project may be used, while choosing the painting scheme applicable.
2. Rust preventive coating should be given on HSEFG bolt and nut threads and inside surfaces of fabricated structure shall be painted with red oxide primer paint during fitup stage.
3. All threaded & machined surfaces are to be applied with a coating of Temporary Rust preventive oil.
4. All surfaces of foundation materials, insulation pins, Anchor channels, Sleeves Splice/ cover plate/ gusset plate and metal contact area usually bolted at site to enhance the load transfer by friction grip shall be coated with temporary rust preventive fluid and during execution of civil works; the dried film coating shall be removed using organic solvents.
5. PGMAs under sub vendor items are not indicated. Please refer respective Engineering document for all sub-vendor items. Whenever it is not specified, it shall be as per the painting scheme of the applicable PGMA.
6. No painting is required for Aluminium, Stainless steel components and galvanized items. Abrasive blast cleaning to SSPC – SP 6 (Sa 2) grade shall be done on any damaged painting area. This repair is not applicable to inorganic ethyl zinc silicate painted component.
7. The Temporary rust preventive coating that has already been applied on any component, tubes, pipes etc shall be visually inspected for good adherence. If the coating is intact, direct coating of alkyd based red oxide paints over the coating is permitted. In case the coating is peeled off over a large area, then the coating is to be removed by suitable solvents/ heating to 350- 400 deg C for an hour before primer paint application- but in this case, it should be ensured that the minimum surface cleanliness required for primer paint application shall be SSPC – SP2 (equivalent- Hand tool cleaning)
8. All currently active PGMAs are covered. Requirements for Missing / new PGMAs will be included under the relevant section following the appropriate paint logic.
9. Ground shade/ color finish paints & identification tag/ band for equipments, supporting structures and other components shall be followed as per tender.
10. In components, wherever plate/ sheets of thickness less than or equal to 4mm, tubes/ rods are used, power/ hand tool cleaning to SSPC- SP3/ SSPC-SP 2 shall be followed and the painting shall be done as per SL no: D/01 of PRQA:590- Section II A/B/C. For all commissioning components- erection materials two coats of Red oxide Zinc phosphate primer shall be applied to meet the temporary protection till erection, after power tool cleaning.
11. Touch-up painting of damaged areas shall be carried out as per clause applicable painting scheme.
12. Structural members having welded connections at site, relevant area can be painted with primer paint instead of weldable primer.
13. This painting scheme is the final document and it overwrites any other document indicating painting/ coating schemes. The component not covered in approved painting scheme, this is the document to decide the type of paint application.
14. All components covered under different PGMAs are to be painted. In case any component is left out, the same shall be deemed to be included under relevant section.

	PROCEDURE FOR SURFACE PREPARATION & PAINTING	Doc no	PRQA:590
		Rev.	02
		Date	24.01.2018
		Page no	35 of 54

ANNEXURE II

INSPECTION & TESTING PLAN FOR SURFACE PREPARATION, PAINTING

SL NO	COMPONENT/ OPERATION	CHARACTERISTICS	CL	TYPE OF CHECK	QUANTUM OF CHECK	REFERENCE DOC/ ACCEPTANCE NORM	TYPE OF RECORD	AGENCY			REMARKS
								M	C		
1.0	Surface preparation for plates/ rolled sections/ components										
1.1	Raw material	Rust, pitting	B	Visual	100%	Note 1	R	P	V	-	
1.2	Blasting media	Type of quality of abrasives	B	Random sample test	Abrasive quality for each lot	Note 1a	R	P	V	-	
1.2.1	Blasting/ Power tool cleaning	Surface roughness/ cleanliness	A	Visual, Measurement	100% 10 spots/ sq.m	Surface profile as per approved painting scheme, Note 2	R	P	W	-	
		Profile defects	B	Visual	100%	Note 3	R	P	W		
1.2.2	Substrate dust contamination (for blasting)	Adhesive Tape test	B	Measurement	Two spots/ component	Note 4	R	P	W	-	Randomly selected 10X magnifier, Transparent adhesive tape 25mm width
1.2.3	Substrate chemical contamination (for blasting)	Surface contamination test	B	Measurement	One test/ abrasive lot used	SSPC SP 12 Chloride <15µg/cm ² (PPM) Sulphate <20 PPM	R	P	W	-	Any suitable method to identify salt contamination
1.2.4	Substrate-coating conditions	Flash rusting steel temperature environmental condition	A	Visual Measurement	100% One spot/ Lot	Note 5	R	P	V	-	
2.0	In process Painting										
2.1	Paint	Physical & Chemical	A	Review of documents	100%	Invoice/ data sheet	TC	P	V	-	Physical verification of shade, batch no, date of manufacture, supplier approval status
2.2	Mixing (Two pack system)	Mixing ratio & Durations	B	Documents	100%	Painting data sheet Note 6	R	P	V	-	Electrical/ pneumatic agitator



**PROCEDURE FOR SURFACE PREPARATION
& PAINTING**

Doc no	PRQA:590
Rev.	02
Date	24.01.2018
Page no	36 of 54

SL NO	COMPONENT/ OPERATION	CHARACTERISTICS	CL	TYPE OF CHECK	QUANTUM OF CHECK	REFERENCE DOC/ ACCEPTANCE NORM	TYPE OF RECORD	AGENCY			REMARKS
								M	C		
2.2.1	Filtering	Free from foreign particle	B	Documents	100%	Use sieves 80-100 microns	R	P	V	-	Nylon mesh or muslin cloth
2.2.2	Paint testing	Physical & chemical properties	C	Lab test	Random	Supplier TC/ Data sheet/ IS specifications	R	P	W		Sample collected at each vendor at regular intervals as advised by BHEL shall be sent to BHEL/ NABL accredited lab
2.2.3	Painting	Personnel qualification	C	Review of documents	100%	In line with this PRQA- Annexure III	R	V	V		
		Inspection personnel	C			Certification by reputed institution or by an Expert. (NACE/SSPC/ Level II)	R	V	V		
2.3	Airless/ Air spray	Spray process pot life	B	Documents	100%	Supplier manual	R	V	V		
						Tip selections, Note 7	R	P	V		
2.4	Coating thickness & coating intervals	Wet film, Dry film thickness	B	Measurement	100%	SSPC- PA 2 Note 8	R	P	V		
		Intervals	B	Documents	100%	Painting data sheet/specification	R	P	V		Min: 24 hrs or as per paint specification / data sheet
3.0	Final Testing										
3.1	Peel off test Cross cut/ X-cut	Adhesive strength between substrate & primer and subsequent over coats	A	Test on each coat: Primer, Intermediate & final coat	3 spots	ASTM D3559-7 Note 9	R	P	W		4x magnifier lens, 25mm width pressure sensitive tape (P99), cutting edges with template

	PROCEDURE FOR SURFACE PREPARATION & PAINTING	Doc no	PRQA:590
		Rev.	02
		Date	24.01.2018
		Page no	37 of 54

SL NO	COMPONENT/ OPERATION	CHARACTERISTICS	CL	TYPE OF CHECK	QUANTUM OF CHECK	REFERENCE DOC/ ACCEPTANCE NORM	TYPE OF RECORD	AGENCY			REMARKS
								M	C		
3.2	Final Inspection	Dry film thickness	A	Document	15 spots/ sq.m	Approved painting scheme, SSPC PA 2	R	P	W		
		Finish, shade and paint defect	A	Visual	100%	Note 8	R	P	W		Use of shade card

NOTE- 1: Rust Grade

As per ISO 8501-1, rust and painting are graded into four categories as A, B, C & D. Rust and pitting shall be removed by competent process prior to application of primer. Pitted area shall be cleaned by blasting/ power tool cleaning/ grinding provided thickness shall be met to the design requirement. Plates/ components identified under heavy pitted category C or D, acceptance/rejection reserved to QC/ BHEL.

NOTE- 1a: Blasting media

Blasting media shall be copper slag, iron slag, steel shots/ grits & aluminum oxide. The abrasive used for blasting process shall be within chemical contaminations chloride <15ppm and sulphate <20ppm. Mixing ratio of shots/ grits (generally 3:1) shall meet the surface roughness 35-50 microns after blasting. Blasting media shall be suitably sieved to get the required particle size 0.5 to 1.0mm. (Steel shots ASTM G40/G80)

NOTE- 2: Blast cleaning

- a) Air quality must be checked before start of blasting process by blotter test
- b) Surface finish: The blasted surface shall meet the SSPC- SP10 (SA 2.5) finish near white metal. Surface roughness shall be checked in 10 spots/Sq.m. Digital/ Analog instrument duly calibrated shall be used to measure the surface roughness. Power tool cleaned surface shall be met to SSPC- SP3. Blasting/ power tool cleaned surface shall be met as per ISO 8501-1 requirement.
- c) Surface roughness: Average value shall be 35-50 microns for blast cleaned surface.
- d) Blasting: Shall not be done during rainy/ mist seasons where relative humidity is more than 80%.
- e) Optimum blasting pressure and nozzle size (straight bore or venturi type) to get required surface roughness (90-100psi for mineral abrasives and 120-125 psi for metallic abrasives, standing distance 12-18 inches and standing angle 80-90 deg. for full blasting, sweep blast 45-60 deg. with respect to the substrate).

	PROCEDURE FOR SURFACE PREPARATION & PAINTING	Doc no	PRQA:590
		Rev.	02
		Date	24.01.2018
		Page no	38 of 54

NOTE- 3: Profile defects

- a) Surface shall be visually checked and free from defects such as rust, dust, grease, oil, sharp corner/edges, rolling imperfection/ overlap, vein, undulations, mill scales, improper weld beads/ shapes/ undercuts, weld slag, spatters etc.
- b) Sharp corner/edges shall be ground off to radius 1.5 to 2mm and blunted. Other profile defects if any shall be ground/chipped out/ repaired by suitable means

NOTE- 4: Dust

A transparent adhesive tape test shall be conducted on substrate to ensure cleanliness of the substrate and same shall meet the class 1 requirement.

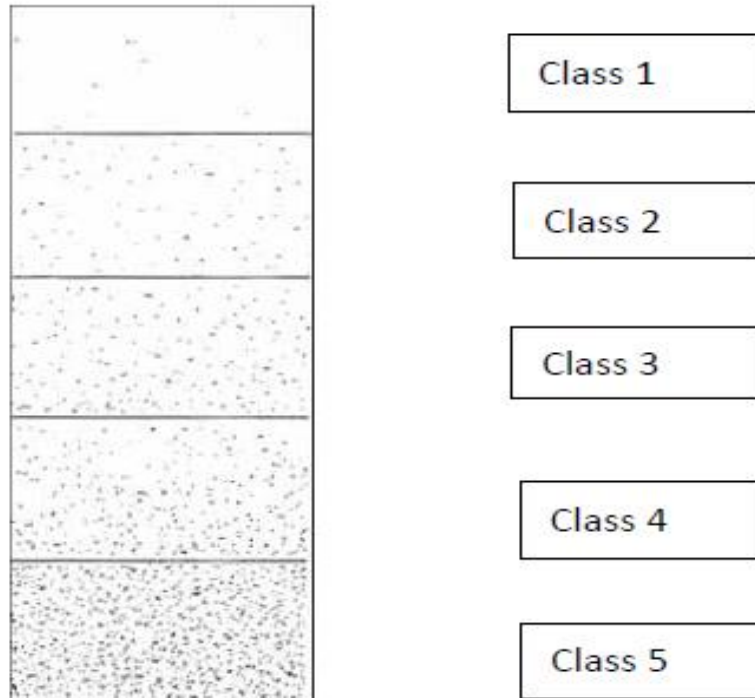

NOTE- 5: Coating conditions

- a) Abrasive media used for blasting shall be free from moisture and other contaminations.
- b) Flash rusting if any shall be removed by sweep blasting

	PROCEDURE FOR SURFACE PREPARATION & PAINTING	Doc no	PRQA:590
		Rev.	02
		Date	24.01.2018
		Page no	39 of 54

- c) Primer paint shall be applied immediately or within 4 hours in case of blast cleaning and within 8 hours in case of power tool cleaning.
- d) Painting shall not be done during rainy/ mist seasons when relative humidity is >80%.
- e) Painting shall be commenced, when the metal surface temperature is >3°C above the dew point temperature
- f) Painting shall not be done, when the steel surface temperature is >45°C.
- g) A suitable instrument duly calibrated is required to check the dew point temperature and steel surface temperature.

NOTE- 6: Mixing

- a) Paint mixing ratio for two packs painting system shall be done as per the painting data sheet provided by the manufacturer. Individual component shall be mixed thoroughly and then mix the component as per data sheet ratio (by volume or by weight). Blend by boxing is prohibited for inorganic zinc rich primer (ie react with moisture). Off ratio (partial ratio) blends won't cure properly.
- b) Mixing of thinner is not required for airless spray, however mixing of thinner <5% is permitted. If required add thinner after mixing of paints and mix it with homogenously.
- c) Paint mixing shall be done at least for not less than 20 minutes or as per paint data sheet with electrical/ pneumatic operated tool to achieve mixing chemically matured.
- d) Mixed paint particles shall be filtered with sieves of 80-100 microns to avoid clogging of nozzle tip. Once components are blended, pot life begins and use the mixed paint immediately as specified pot life period indicated in the data sheet.
- e) Zinc rich primers dispersed slowly in to binder and agitate slowly while mixing process.
- f) Primer, Intermediate and final coat shall be the same supplier, if any change, compatibility certificate shall be obtained from the paint supplier.

NOTE- 7: Spray process

- a) Painting shall be done at controlled environment only and free from dust& paint soot.
- b) When volume of solids of paint s more than 50%, airless spray shall be selected for painting application.
- c) Select proper nozzle tip size and pressure to achieve uniform DFT and less wastage.
- d) Painting shall be done within pot life period specified in the paint product data sheet, to avoid premature paint failure.
- e) Avoid arcing, tilting and maintain constant distance (12-18 inch), tip selection, tip pressure according to paint, triggering at appropriate locations and banding while painting.
- f) While painting of inorganic zinc silicate, RH shall be above 65%, if painted below RH 65% water curing is required.
- g) Top coat over and above epoxy intermediate coat shall be done within a month and proper roughness shall be created before top coat.

	PROCEDURE FOR SURFACE PREPARATION & PAINTING	Doc no	PRQA:590
		Rev.	02
		Date	24.01.2018
		Page no	40 of 54

NOTE- 8: Coating Thickness

- a) Wet film thickness (WFT) shall be measured immediately after paint applications using Comb gauge/ eccentric wheel.
- b) WFT can be calculated as: $WFT = (100 \times DFT) / VS$ where, DFT is the dry film thickness and VS= % of volume solid of supplied paint from data sheet.
- c) Dry film thickness shall be measured after hard dry condition of each coat.
- d) Dry spray/ Dust particles embedded after previous coat shall be cleaned/ removed with fine emery paper prior to application of subsequent coat. Coating thickness shall not be less than the requirement as specified in the painting scheme at any case tolerance on total DFT as specified in the applicable painting scheme shall be within -0/+20 microns or +10% of total DFT, whichever is higher.
- e) Coating thickness shall not be less than the requirement as specified in the painting scheme at any case tolerance on total DFT as specified in the applicable painting scheme shall be within -0/+20 microns as specified in the applicable painting scheme.
- f) Painted surface shall be free from paint defects namely crack, sagging, dry spray, orange peel etc.
- g) Finish and shade as per paint data sheet. A painted panel shall be made available with at works to check/ compare the painted surface.

NOTE- 9: Peel off Test

- a) Paint peel off test shall be done after 48 hours of painting operation, on single/ multi coated painted surface of the component for each coat.
- b) When total DFT is less than 125 microns- Cross cut method shall be followed.
- c) DFT up to 50 microns 1mm spacing with 6 cuts minimum to the length of 20mm.
- d) DFT more than 50 microns and less than 125 microns 2mm spacing with 6 cuts minimum to the length of 20mm.
- e) When total DFT is more than 125 microns- X cut method shall be followed. The smaller angle of cut shall be between 30 to 45 degrees cut to length of 40mm.
- f) For all tests, ensure that coating film has been penetrated and minimum three locations shall be tested.
- g) The adhesion test shall be conducted where the substrate temperature is below 35°C for alkyd base paints.

	PROCEDURE FOR SURFACE PREPARATION & PAINTING	Doc no	PRQA:590
		Rev.	02
		Date	24.01.2018
		Page no	41 of 54

Acceptable norm for Cross cut method:

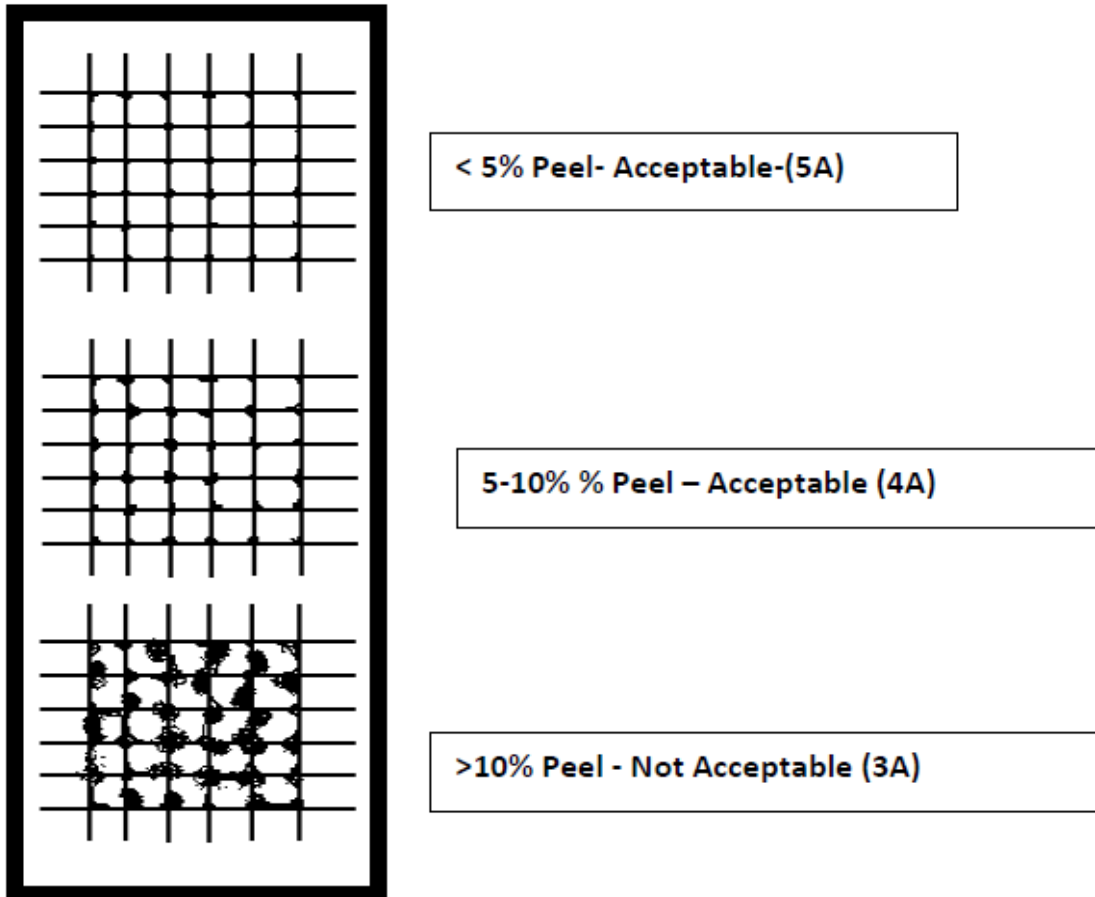

Acceptable norm for X cut method:

5A- No peeling- Acceptable

4A- Trace peeling along incisions or at their intersection- Acceptable

3A- Jagged removal along incision up to 1.6mm on either side- Not acceptable

	PROCEDURE FOR SURFACE PREPARATION & PAINTING	Doc no	PRQA:590
		Rev.	02
		Date	24.01.2018
		Page no	42 of 54

PAINTING INSPECTION FORMATS

VENDOR CODE		I ST VENDOR : FABRICATION/ 2 ND VENDOR BLASTING							
		SURFACE PREPARATION (POWER TOOL/BLASTING REPORT							
PAINTING SCHEME					REPORT NO& date				
PROJECT					PO.NO.				
WO.NO.									
PRODUCT DESCRIPTION									
SURFACE PREPARATION (REF STANDARD ISO 8501)									
Sieve size used and size of abrasive									
BLASTING MEDIUM USED				RAW MATERIAL RUST GRADE					
				A	B	C	D		
DU .NO	QTY	TEMPERATURE			RH	DATE	START TIME	END TIME REMARKS	
		DRY BULB	WET BULB	DEW POINT					
MOISTURE CONTENT TEST FOR IF COMPRESSED AIR USED (BLOTING PAPER CHECK)							OK / NOT OK		
SURFACE PROFILE GAUGE READING(IN MICRONS) DATE & TIME SURFACE FINESH TO SA 2.5 (SSPC SP 10)/ SURFACE CLEANLINES FOR POWER TOOL CLEANING									
SURFACE SALT CONTAMINATION TEST(IF ANY) FOR BLASTED SURFACE					REPORT		OK / NOT OK		
DUST FREE CHECK TEST FOR BLASTED SURFACE		TAPE REPORT							
DUST FREE CHECK RESULT LEVEL FOR BLASTED SURFACE					1	2	3	4	5
Visual inspection(pitting, weld spatter/slag, rolling defects ,etc.,									
FIRM QC					TPI /BHEL QC				



**PROCEDURE FOR SURFACE PREPARATION
& PAINTING**

Doc no	PRQA:590
Rev.	02
Date	24.01.2018
Page no	43 of 54

VENDOR CODE	1 ST VENDOR; FABRICATION, 2 ND VENDOR: PAINTING									
	PAINT REPORT									
PAINTING SCHEME		REPORT NO & date								
PROJECT		PO.NO.								
WO.NO.										
PRODUCT										
PRIMER COAT PAINT										
PAINT SPECIFICATION/STD IS No:..... /SHADE										
PAINT MANUFACTURER										
SUPPLIER/TRADER NAME										
MANUFACTURING DATE / BATCH NO. / TC No										
MIXING RATIO / TWO PART SYSTEM IF ANY										
NUMBER OF COAT										
DURATION OF MIXING (use of stirrer) DATE / TIME :										
DU NO	QTY	TEMPERATURE					DATE	START TIME	END TIME	REMARKS
		DRY BULB	WET BULB	METAL SURFACE	DEW POINT	RH				
WET FLIM THICKNESS (in microns)										
SPRAY GUN USED										
HARD DRY TIME (REQUIED)										
DFT REQUIRED										
DFT ACTUAL MEASURED (SSPC PA 2)										
Visual inspection(pitting,weld spatter/slag,rolling defects ,etc.,) / paint defect										
PEAL OFF TEST(AST M- D3359)	CROSS CUT TEST DFT UP TO 50 MICRONS PITCH 1mm , cut Length 20mm					REPORT	OK / NOT OK			
	CROSS CUT TEST DFT BETWEEN 50 TO 125 MICRONS PITCH 2mm, cut length 20 mm					REPORT	OK / NOT OK			
	X CUT TEST ABOVE 125 MIC(included angle 30 to45 deg, cut length 40mm)					REPORT	OK / NOT OK			
FIRM QC						TPI /BHEL QC				



**PROCEDURE FOR SURFACE PREPARATION
& PAINTING**

Doc no	PRQA:590
Rev.	02
Date	24.01.2018
Page no	44 of 54

VENDOR CODE	1ST VENDOR;FABRICATION 2ND VENDOR: PAINTING									
	PAINT REPORT									
PAINTING SCHEME	-					REPORT NO& Date				
PROJECT						PO.NO.				
WO.NO.										
PRODUCT										
INTERMEDIATE/FINAL COAT										
PAINT SPECIFICATION/ SHADE										
PAINT MANUFACTURER										
SUPPLIER/TRADER NAME										
MANUFACTURING DATE / BATCH NO. / TC No./DC										
MIXING RATIO / TWO PART SYSTEM IF ANY										
NUMBER OF COAT										
DURATION OF MIXING (use of stirrer) DATE / TIME :										
DU NO	QTY	TEMPERATURE				RH	DATE	START TIME	END TIME	REMARKS
		DRY BULB	WET BULB	METAL SURFACE	DEW POINT					
WET FLIM THICKNESS (in microns)										
SPRAY GUN/NOZZLE NO USED										
HARD DRY TIME (REQUIRED)										
DFT REQUIRED										
DFT ACTUAL MEASURED (Not less than specified in painting scheme)										
Visual /paint defect (if any)										
Peel of test (ASTM-D3359)	CROSS CUT TEST DFT BETWEEN 50 TO 125 MICRONS PITCH 2mm, cut length 20 mm					REPORT	OK / NOT OK			
	X CUT TEST ABOVE 125 MIC(cut included angle 30 to 45 deg, cut length 40mm)					REPORT	OK / NOT OK			
FIRM QC						TPI/BHEL QC				

	PROCEDURE FOR SURFACE PREPARATION & PAINTING	Doc no	PRQA:590
		Rev.	02
		Date	24.01.2018
		Page no	45 of 54

ANNEXURE III

PROCEDURE FOR QUALIFICATION OF PAINTERS

1.0 SCOPE

This standard describes, in general, the procedure and criteria to be followed for qualifying an operator/ painter for carrying painting work at BHEL Shop or at vendor works.

2.0 OBJECTIVE:

To evolve criteria and procedure for qualification of operators/ painters.

3.0 PROCEDURE:

Following procedure shall be adopted for certification of operator/ painter qualification for carrying out painting process.

- 3.1 Vendor shall initiate the format 'Record of personnel deployed for painting work' as shown in Annexure III A. This annexure is subsequently forwarded to concerned department of the unit.
- 3.2 Concern department is to forward to the reputed agency/expert having NACE/ SSPC (Level II) shall assess and certify the suitability of an operator / painter to conduct a painting process. In case, a new operator/ painter is inducted shall have experience in the painting field minimum 2 years and qualification not less than VII std, then he shall be assessed by reputed agency/expert. In case, an operator/painter does not carry out painting work for more than two years, then he shall be re-qualified and issued a certificate in line with the annexure.
- 3.3 An operator/ painter engaged in carrying special process like painting shall be re-qualified once in 3 years.
- 3.4 Following criteria have been identified and evaluated for each operator/ painter. Each criterion has been allocated 10 marks.
 - 3.4.1 Mainly, there are three types of painting processes which are being followed for carrying out painting, these are
 - Brush application
 - Air spray painting
 - Airless spray painting/ Air assisted airless spray

The operator is expected to know the basics of the above painting processes, technical details of process equipment and their salient features, awareness about Do's and Don'ts in painting work.

	PROCEDURE FOR SURFACE PREPARATION & PAINTING	Doc no	PRQA:590
		Rev.	02
		Date	24.01.2018
		Page no	46 of 54

3.4.2 Understanding of the documents/ specification

The operator/ painter should have the knowledge about surface cleaning and acceptance norms, paint systems, mixing ratio and pot life of two pack systems, drying and curing behavior, use of proper thinner, control of viscosity and its importance, over-coating interval, precautions to be observed during their use etc.

3.4.3 Awareness about handling of materials/ jobs

The operator/ painter is expected to have knowledge about handling of paint components like base, hardener and thinner, handling and upkeep of painting equipment, cleaning of brush, gun and other parts of equipment. He is also expected to know how to handle cleaned and painted jobs.

3.4.4 Performance evaluation based on job/samples

The operator / painter shall be asked to prepare the test panel/job which shall be evaluated for following parameters:

- Uniformity of coating + 10% DFT required.
- Visual defects like brush marks, wrinkles, pinholes etc.
- Surface finish, gloss
- Presence of dry spots, overflow marks

The operator/ painter shall first clean the test panels thoroughly followed by a coat of primer/ finishing paint etc, using requisite painting process , i.e., brush/ air spray/ airless spray etc. After evaluation of test panels and based on result, the marks shall be allotted. After evaluation of test panels and based on result, the marks shall be allotted.

3.4.5 Knowledge about safety and hygiene

Each operator/ painter is expected to know about the safety of self and surroundings, use of safety appliances, effect of solvent vapors on health etc. He is supposed to know personal hygiene as well as upkeep of painting equipment and painting area.

3.4.6 Classroom training

A class room training by the supplier/ expert (manufacturer like Nerolac, Berger etc) of the paint which we are procuring, must be arranged for the painters to have knowledge about the paints, enamels, coatings etc and their applications. The class room training must be arranged in local languages for understanding of the painters.

4.0 CERTIFICATION FOR QUALIFICATION

Each operator/ painter is evaluated for above criteria and marks are being allotted for each criterion. The operator/ painter must obtain a minimum marks 5 for each criteria and

	PROCEDURE FOR SURFACE PREPARATION & PAINTING	Doc no	PRQA:590
		Rev.	02
		Date	24.01.2018
		Page no	47 of 54

qualifying marks shall be 25 out of 50. The painter should pass in field/ practical test, even performed well in the written examination. The certification shall be specified in the area of type of application process as a painter is qualified. (example: airless/ spray/ pressure pot/ air spray) etc.

5.0 ISSUE OF CERTIFICATE

The operator/painter who qualifies the test shall be issued a certificate in standard format shown below, which shall be kept in the concerned and certifying department/ vendor works for record. The format can be modified to suit the requirement at vendor works with prior approval from QA. This certificate shall be signed by initiating section in charge and certifying department/ reputed agency/expert

6.0 VALIDITY

The validity of the certificate is for 3 years from the date of issue. The operator/ painter is required to appear for re-test to extend the validity.

 Ranipet	PROCEDURE FOR SURFACE PREPARATION & PAINTING	Doc no	PRQA:590
		Rev.	02
		Date	24.01.2018
		Page no	48 of 54

Annexure III- A

RECORD OF TRAINING & QUALIFICATION FOR PERSONNEL TO BE DEPLOYED FOR PAINTING PROCESS

VENDOR NAME AND ADDRESS

1. Name :
 2. Father's name :
 3. Date of birth/ Age :
 4. Basic Qualification :
 5. Experience in the painting field :

 Name of Expert trainer :
 Designation :



Date of start of training	Training subject	Faculty	Duration (Hrs.)	Certificate issued Yes/no	Remarks
	1.Painting process and Equipment		2		Issued on
	2.Painting Document/ Data sheet/Batch TC		1		Validity up to:
	3.Knowledge of paint component and mixing		1		
	4.Painting performance Evaluation on sample		2		
	5. Safety and hygiene		1		

Marks obtained: (each section carry 10 marks)

- 1) Knowledge of painting process and equipment : -----
 2) Understanding of documents / specification : -----
 3) Handling of components : -----
 4) Performance evaluation based on jobs/samples : -----
 5) Knowledge of safety and hygiene : -----

Qualifying marks are 25/50

Qualified for : Airless spray & air spray
 Painting System : Alkyd/ Epoxy/zinc silicate and heat Resistant based paints

Signature of
Initiating Official

Signature of
Certifying expert

	PROCEDURE FOR SURFACE PREPARATION & PAINTING	Doc no	PRQA:590
		Rev.	02
		Date	24.01.2018
		Page no	49 of 54

ANNEXURE IV

Painting Scheme- Details for procurement and application process

Sl no	Generic nature of paint	Theoretical covering capacity Sq. m per litre	No of pack	Volume solids % (min)	DFT in microns (min) per coat	Shade	Shade no to IS 5	Mode of appln	Over coating Interval hrs
01	Heat resistant Aluminium paint to IS 13183 Gr. I	10	1	--	--	Aluminium	--	Brush/ Spray	24
02	Heat resistant Aluminium paint to IS 13183 Gr. II	10	1	--	--	Aluminium	--	Brush/ Spray	24
03	Red oxide zinc phosphate primer to IS 12744	10	1	--	--	Red oxide	--	Brush/ Spray	12
04	Epoxy Zinc rich primer to IS 14589 Gr.II	8	2	35	40	Grey	--	Spray	24
05	HB Chlorinated rubber based zinc phosphate primer	10	1	40	50	Grey	--	Brush/ Spray	12
06	Epoxy based zinc phosphate primer to IS 13238	10	2	40	35	Grey	--	Spray	24
07	Inorganic Ethyl Zinc silicate to IS 14946	8	2	60	65	Grey	--	Spray	24
08	Polyamide cured Epoxy based MIO/ TiO ₂ pigmented intermediate coat	8	2	50	75	Grey/ Brown	--	Spray	16
09	Long oil alkyd synthetic enamel finish paint to IS 2932	10	1	--	--	Reqd. shade	Corr dg. Shade no	Brush/ Spray	12
10	Epoxy based polyamide cured finish paint to IS 14209	10	2	40	35	Smoke grey/ Grey white	692 RAL 9002	Spray	24
11	Aliphatic acrylic polyurethane paint to IS 13213	10	2	40	30	--	--	Spray	24

	PROCEDURE FOR SURFACE PREPARATION & PAINTING	Doc no	PRQA:590
		Rev.	02
		Date	24.01.2018
		Page no	50 of 54

Sl no	Generic nature of paint	Theoretical covering capacity Sq. m per litre	No of pack	Volume solids % (min)	DFT in microns (min) per coat	Shade	Shade no to IS 5	Mode of appln	Over coating Interval hrs
12	Temporary rust preventive fluid (Non- drying type) to PRQA 522 (Latest)- For APH Elements	10	1	--	--	Black	--	Dip	--
13	Temporary rust preventive fluid (Drying type) to TEP:AQCS:RP (Latest)- For CE coils	10	1	--	--	Black	--	Dip	--
14	Temporary rust preventive fluid (Drying type) to PRQA:523 (Latest) for other components	10	1	--	--	Amber	--	Brush/ Spray	12
15	Sea worthy rust preventive fluid to PRQA:524 (Latest) for other components	10	1	--	--	Amber	--	Brush/ Spray	12

	PROCEDURE FOR SURFACE PREPARATION & PAINTING	Doc no	PRQA:590
		Rev.	02
		Date	24.01.2018
		Page no	51 of 54

ANNEXURE V

GOOD PAINTING PRACTICES (DO's and DON'Ts IN PAINTING):

1.0 Do's:

- a) Remember, painting is an important value adding activity. Give it all your care.
- b) Store paints in covered places. Avoid direct exposure to sunlight on paints.
- c) Ensure the validity of the shelf life of the paint before use.
- d) Roll the paint drum several times to ensure thorough mixing of the paint before use.
- e) Use proper tools to open lid of the drum.
- f) Mix the paints thoroughly to ensure homogeneity.
- g) Apply strip coat on edges, corners and weld beads.
- h) Follow instructions on the paint can or literature whenever a new scheme/ source of paint is used.
- i) Draw only the required quantity of the paint for the job and immediately recap the can.
- j) Ensure proper ratio of mixing in case of two pack system, as per norms.
- k) Use only the specified thinner prescribed by the supplier or standard.
- l) Ensure good quality of compressed air (free from moisture and oil) prior to spray painting.
- m) Use only clean/ new brushes of definite size for painting.
- n) Clean the bristles well in the thinner before they are used for the painting.
- o) Painting shall be done in a well-ventilated area/ identified area
- p) Ensure proper surface preparation as per the painting scheme.
- q) Ensure that the blasted surface be painted within 4 hours after blasting.
- r) Ensure that the surface to be painted is free from oil, grease, stay arcs, dents etc.
- s) Adhere to the number of coats shade, dry film thickness and inter-coat curing time interval as specified. Clarify with lab, if needed.
- t) Use lint free cloth/ clean wiping rags for cleaning the surfaces prior to the painting.
- u) Maintain the right distance between the surface and spray gun (6 inches to 8 inches)
- v) Ensure that the mixed paints will be used before the expiry of its pot life in case of two-pack systems.
- w) Ensure that the items to be painted are inspected and cleared by the inspection personnel concerned.
- x) Preserve the balance thinned paints in a separate closed container for future use, if they don't have any restricted pot life.
- y) Clean the brush before and immediately after painting. Keep them clean during interruptions too.

	PROCEDURE FOR SURFACE PREPARATION & PAINTING	Doc no	PRQA:590
		Rev.	02
		Date	24.01.2018
		Page no	52 of 54

2.0 Don'ts:

- a) Do not use the paint, which has crossed its expiry date.
- b) Do not draw more paint than necessary from the stores.
- c) Do not make holes in the drum to draw the paint.
- d) Do not keep the paint drum open for a long time.
- e) Do not interchange the thinners for the same generic paint between suppliers.
- f) Do not use kerosene as thinner.
- g) Do not smoke while painting.
- h) DO not leave the brush without cleaning after painting.
- i) Do not paint close to a welding area.
- j) Do not paint when there is rain or sandstorm or when the relative humidity is about 90%.
- k) Do not paint when the metal is chill (temp < (dew point + 3°C) or very hot (> 48°C)
- l) Do not paint when the surface is not cleaned/ prepared for painting requirements.
- m) Do not paint the finish coat if the primer coat is not satisfactory.
- n) Do not leave the balance paint open after painting.
- o) Do not use VCI pellets for stainless steel components and its composite assemblies.

3.0 CLEANING OF PAINTED & RUST PREVENTIVE COATED SURFACES

Wherever required, paints and rust preventive protection can be removed either by using the following commercial solvents or by flame cleaning/ blasting

For rust preventive	Acetone, Methyl Ethyl ketone or Tri-chloro Ethylene
For all paints	Alkaline paint strippers or Solvent based paint strippers

4.0 SURFACE PREPARATION

- Surfaces of components shall be thoroughly cleaned before the application of primer paint and shall be free from grease, oil, rust, weld slag, spatters etc.
- Abrasive blast cleaning to SSPC SP6 (Sa 2) grade shall be done to prepare the surfaces of hot worked pipes prior to application of primer.
- A comparative chart indicating the surface preparation standard equivalents is given below for ready reference.

	PROCEDURE FOR SURFACE PREPARATION & PAINTING	Doc no	PRQA:590
		Rev.	02
		Date	24.01.2018
		Page no	53 of 54

DESCRIPTION	SSPC SCHEME	SWEDISH STANDARD SIS - 05 - 5900
Solvent cleaning	SSPC- SP 1	-
Hand tool cleaning	SSPC- SP 2	St2
Power tool cleaning	SSPC- SP 3	St3
Flame cleaning	SSPC- SP 4	F1
Blast cleaning to White metal	SSPC- SP 5	Sa3
Commercial blast cleaning	SSPC- SP 6	Sa2
Brush off blast cleaning	SSPC- SP 7	Sa1
Pickling	SSPC- SP 8	-
Blast cleaning to near white metal	SSPC- SP 10	Sa 2½

5.0 APPLICATION OF PAINT

- a) Primer paint shall be applied immediately or within 4 hours in the case of shot blast cleaning and within 8 hours for mechanical cleaning.
- b) Wherever tubes/ pipes are not either shot blasted or heat treated during manufacture, the rust preventive coating provided by the tube/ pipe mill shall be treated as base for primer coating for subsequent painting of alkyd base paints like one coat of red oxide zinc phosphate (when called for). When special paint is specified in the painting scheme, the existing rust preventive fluid is to be removed by blast cleaning. However, rusted areas are to be cleaned free of oil, grease, rust etc. thoroughly using emery paper/wire brush and making rust preventive coated surfaces coarse.
- c) Ready mixed paints shall be used as supplied by the supplier without any addition of thinner unless otherwise specified. Two pack systems are to be used as per supplier's instructions.
- d) Wherever second coat of finish coat is to be applied in succession, 24 hours minimum drying time shall be provided between each coat for single pack paints. For two-pack system refer paint supplier's catalogue.
- e) No painting is required in case of Stainless Steel, Aluminium and Galvanized components, unless otherwise specified in contracts.
- f) For all machined components, rust preventive fluids shall be applied.
- g) All weld edge preparations for site welding shall be applied with one coat of weldable primer. For small components having weld ends on both sides, full surface can be painted with weldable primer.
- h) Part processed items meant for shop assembly shall be painted at sub-contractors works with primer/ special paints (when called for in the painting scheme) based on the scope

	PROCEDURE FOR SURFACE PREPARATION & PAINTING	Doc no	PRQA:590
		Rev.	02
		Date	24.01.2018
		Page no	54 of 54

of the indent/ purchase order. Further paint touchup/ Coating shall be given appropriately during assembly.

- i) For items meant for Spares and subcontracting where no further processing is involved, the painting scheme selected shall be the same as that of similar product configuration / description and not with respect to PGMA. All running meter items for spares one coat of red oxide primer and two coats of Synthetic enamel paint to IS 2932 (Latest) shall be supplied.
- j) Assemblies consisting of machined components and special equipments shall not be shot blasted wherever it may affect the system. In such cases power tool cleaning may be adopted for the localized areas only.

SHARAT HEAVY ELECTRICALS LTD
BOILER AUXILIARIES PLANT
ANIPET-632 406 (INDIA)
QUALITY ASSURANCE DEPT.

STANDARD QUALITY PLAN FOR WELDING

MASTER COPY

Q.P.No. SQM/01
REV.No. NIL
DATE 10-06-93
PAGE 01 of 02

PREPARED BY: *V. Jayaram*

REVIEWED BY: *M. Tammish*

APPROVED BY: *M. Tammish*

No.	COMPONENT & OPERATION	CHARACTERISTICS	CLASS	TYPE OF CHECK	QUANTUM OF CHECK	REFERENCE DOCUMENT	ACCEPTANCE STANDARD	FORMAT OF REC	AGENCY	REMARKS
2	3	4	5	6	7	8	9	10	11	
1	WELDING ELECTRODE/FLUXES	CHEMISTRY	M	LAB TEST	EACH BATCH	AWS A5.1, 5.7 5.5, 5.17 or 5.18	AWS A5.1, 5.5 5.7, 5.17 or 5.18	TC	SUPPLIER	*T.C's WILL BE MAINTAINED BY WTC
2	STORAGE OF ELECTRODES/FLUXES IN STORES	METHOD OF STORAGE	MAJOR	VISUAL	100%	AS PER AWS 5.8, 5.17	A5.1, 5.5, 5.18 etc		STORES WTC	
3	ISSUE CONTROL	METHOD OF ISSUE	MAJOR	WQR	10%	AS PER WTC	DP&DI		WTC	
4	WELDER QUALIFICATION	WQR	MAJOR	LIST OF QUALIFIED WELDERS IN PRODN BAYS TO BE CHECKED	100%				WTC	VERIFICATION OF RECORD i.e, WQR
5	PROCEDURE QUALIFICATION	WPS	MAJOR	WPS TO BE VERIFIED FOR THE PARTICULAR MATL. COMBINATION	100%		ONLY THE QUALIFIED/PRE-QUALIFIED PROCEDURE FOR PARTICULAR MATERIAL COMBINATION AND POSITION METHOD SHALL BE USED		LIST OF QUALIFIED WELDER WTC	VERIFICATION OF RECORDS i.e, WPS
6	BAKING & DRYING OF LOW H2 ELECTRODES	DRYNESS OF LOW HYDROGEN ELECTRODES	MAJOR	VISUAL	RANDOM	WTC I:002/REV 02 DT. 15.7.93 AWS D.1.1 (LATEST)			LOG BOOK WTC	VERIFICATION OF RECORDS AT RANDOM

STANDARD QUALITY PLAN FOR
WELDING

Q.P. SQW01
REV. NO. NIL
DATE 10.06.93
PAGE 02 OF 02

1	2	3	4	5	6	7	8	9	10	11
7	PREHEAT, INTER PASS HEAT POST HEATING	TEMPERATURE OF JOB	MAJOR	BY THERMAL CHALK	RANDOM	PR:QA:/WPS/ OPS AND APPLICABLE	COLOUR CHANGE TO INDICATE CORRECT TEMP		PRODN/ QC	WITNESS AT RANDOM
8	ROOT WELDING OTHER WELDING	QUALITY OF WELD, INTER PASS CLEANING WIRE BRUSHING GRINDING	MAJOR	VISUAL	RANDOM	AS PER APPLI CABLE WPS, OPS, QCP, PR:QA	NO CRACKS ALLOWED		PRODN/ QC	WITNESS WELD REINFORCEMENT WELD UNDERCUT STANDARD REF. OF INSTRUMENT USED
9	NDE	QUALITY OF WELD	MAJOR	UT, RT PT, MT	AS PER APPLICABLE WI	AS PER APPLICABLE WORK INSTRUCTIONS		HC	QC	WITNESS
10	FILLET SIZES OF FILLET WELD	SIZE OF WELD	M	FILLET GAUGE CHECK	100%	AS PER DRAWING		HC	QC	WITNESS
11	POST WELD HEAT TREATMENT	CORRECTNESS OF SRT CYCLE	C	VERIFICA TION OF CYCLE AS PER PRODUCT HT CYCLE FROM HT SCHEDULE HT:001	100%	TEMPERATURE AT WHICH JOB LOADED IN FURNACE HEAT ING RATE SOAKING RATE SOAKING TIME COOLING RATE TEMPERATURE TO WHICH JOB TO BE FURNACE COOLED	AS PER SRT CYCLE IN HT:001 FOR THE PARTICULAR COMPONENT	HC	PRODN/ QC	VERIFICATION HT CYCLE

	QUALITY ASSURANCE	QCP : E : 002
	QUALITY CONTROL PROCEDURE FOR SPLICING NORMS FOR SHEETS / PLATES / STRUCTURALS APPLICABLE TO ESP COMPONENTS FABRICATION	Rev. No. 03
		DT. 30.05.2013

QUALITY CONTROL PROCEDURE

FOR SPLICING NORMS FOR SHEETS / PLATES / STRUCTURALS APPLICABLE TO ESP COMPONENTS FABRICATION

PREPARED BY :

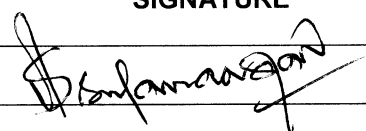
DEPARTMENT	NAME & Designation S/Shri	SIGNATURE
QA	K. Jothi Arulanandam Dy.Mgr/QA	

REVIEWED BY:

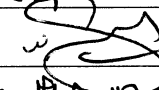
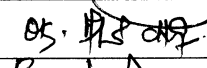
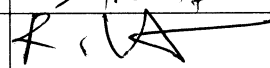
DEPARTMENT	NAME & Designation S/Shri.	SIGNATURE
EDC / AQCS	C. Ganesh Sr.Mgr/AQCS	
OUT SOURCING	N. Nandagopal Sr.Mgr/OS	
QUALITY CONTROL	O. K. Abdulhuq Sr.Mgr/QC-OLI	
QUALITY ASSURANCE	R. Arunachalam Mgr/QA	

APPROVED BY

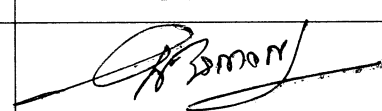
DEPARTMENT	NAME & Designation S/Shri	SIGNATURE
QA	G. BALASUBRAMANIAN SR.DGM / QA, QC(Proc.) & BE	

	QUALITY ASSURANCE	<i>QCP : E : 002</i>
	QUALITY CONTROL PROCEDURE FOR SPLICING NORMS FOR SHEETS / PLATES / STRUCTURALS APPLICABLE TO ESP COMPONENTS FABRICATION	<i>Rev. No. 03</i>
		<i>DT. 30.05.2013</i>

03	30.05.2013	Amendment A1 merged. Feedback from OS and Engg (AQCS) Splicing Norms with applicable Drawing for carbon steel materials and SS Liner Sheet were added and re-issued.
02	03.03.2000	Feedback from MSA and Engg were included and re-issued.
01	16.06.1999	All amendments were merged, feedback from Engg and MSA were included and re-issued.
00	30.10.1985	Original Issue
REV. NO.	EFFECTIVE DATE	REVISIONS MADE

HISTORY OF RECORD OF REVISIONS

1.0 SCOPE

- 1.1 This Quality Control Procedure (QCP) specifies the requirements for splicing of sheets / plates / structural which may warrant joints to make the required length / width in order to achieve the final product as per drawing.
- 1.2 This QCP is applicable to Sheets / Plates / Structural – Angles, Beams of all types, Sections of Rolled / Built up, Rounds, Pipes and Tubes.
- 1.3 The splicing norms dealt in this QCP is applicable to following ESP components ;
- 1.3.1 7X-X42 Outer Roof Assy
 - 1.3.2 7X-X44 Hopper Upper & Middle
 - 1.3.3 7X-X45 Hopper Lower with SS Liner Sheet
 - 1.3.4 7X-X46 Insulator Support Panels
 - 1.3.5 7X-X47 Inner Roof Panel Assy
 - 1.3.6 7X-X49 Casing Shell Panels
 - 1.3.7 7X-X50 Inlet / Outlet Funnel
- 1.4 This QCP covers both Carbon Steel and SS Liner Sheet materials applicable to ESP Components.

2.0 SPLICING NORMS - GENERAL POLICY

- 2.1 The fabricator or OS cutting plan section shall categorically try to avoid joints as much as possible with the supplied raw materials.
- 2.2 Further to explain the point no. 2.1 – the fabricator and OS cutting plan section shall try to make the supplied raw materials without any joints to cover up the loaded quantities – Eg., Out of 10 Nos of casing shell Panels loaded - maximum no. of panels shall be accommodated without any joints by fabricator and only to reduce the material wastage the balance quantity of casing shell panels shall be made with permitted joints as applicable.



QUALITY ASSURANCE

QUALITY CONTROL PROCEDURE FOR SPLICING NORMS FOR SHEETS / PLATES / STRUCTURALS APPLICABLE TO ESP COMPONENTS FABRICATION

QCP : E : 002

Rev. No. 03

DT. 30.05.2013

2.3 The joints permitted are considered with a following view only

- 2.3.1 To reduce the material wastage
- 2.3.2 To make the best use of supplied raw materials sizes without prejudice to appearance and quality of final product as applicable
- 2.3.3 Aesthetic appearance shall not be sacrificed in accommodating the splicing norms.
- 2.3.4 Splicing Joints shall be avoided where a cross member is meeting or on bolt hole region. This is to be strictly adhered by fabricator and shall study the drawing fully with all the matching components.

2.4 ESP Components where joints are not permitted

- 2.4.1 Shock Beam
- 2.4.2 Rapping Shaft
- 2.4.3 Vertical Beam
- 2.4.4 Foundation Bolt
- 2.4.5 Suspension Rod
- 2.4.6 Emitting Frame Top, Middle and Bottom
- 2.4.7 Collecting Suspension Arrangements
- 2.4.8 Lifting Holder
- 2.4.9 Vertical Stay
- 2.4.10 Shock bar

3.0 SPLICING NORMS – SPECIFIC TO RAW MATERIALS

3.1 SHEETS / PLATES (CARBON STEEL)

- 3.1.1 The preparation of joints shall be staggered one so that formation of (+) plus type joint is avoided. The minimum offset (staggering) to avoid the plus type joint shall be minimum 100mm.
- 3.1.2 For a surface area including 2 Mtr X 2 Mtr and less - the permitted smallest dimension of any piece shall be minimum 400 mm (either length wise or breadth wise) and the same will be 600mm minimum for more than 2 Mtr X 2 Mtr surface area – Refer sketch - S1
- 3.1.3 The distance between nearest stiffener and the joint parallel to it shall be minimum 50mm – Refer sketch – S1
- 3.1.4 The vertical joint is permitted on the taper portion. However the distance between meeting of the vertical joint with the horizontal joint shall be minimum 100mm – Refer sketch – S1
- 3.1.5 Butt weld reinforcement shall be ground flush wherever stiffeners cross them.
- 3.1.6 When bending of the plate is done before welding, the parallel joints shall be minimum 100 mm away from the bend line. The weld quality shall be ensured by



QUALITY ASSURANCE

QUALITY CONTROL PROCEDURE FOR SPLICING NORMS FOR SHEETS / PLATES / STRUCTURALS APPLICABLE TO ESP COMPONENTS FABRICATION

QCP : E : 002

Rev. No. 03

DT. 30.05.2013

MPI / LPI. If the weld joint is subjected to bend, the weld shall be checked by LPI subsequent to bending.

3.1.7 The maximum number of permitted joints shall be as given below for carbon steel sheets / plates

SI. No.	Surface Area in Sq. Mtr	Maximum No. Of joints permitted put together both axis (X & Y)
1	Less than & Up to 2	1
2	More than & Up to > 2 < 5	3
3	More than & Up to > 5 < 10	6
4	More than & Up to > 10 < 15	7
5	More than & Up to > 15 < 20	9
6	More than & Up to > 20 < 25	11
7	More than & Up to > 25 < 30	13
8	More than > 30	15

NOTE: The above permitted joints supersedes the maximum no. of joints given in clause no. 4.13 & 4.14 of SQP:ESP:284 Rev.01 Dtd.06.06.2007

3.1.8 The maximum number of permitted joints shall be as given below for **SS Liner sheets** applicable to ESP Lower hopper area;

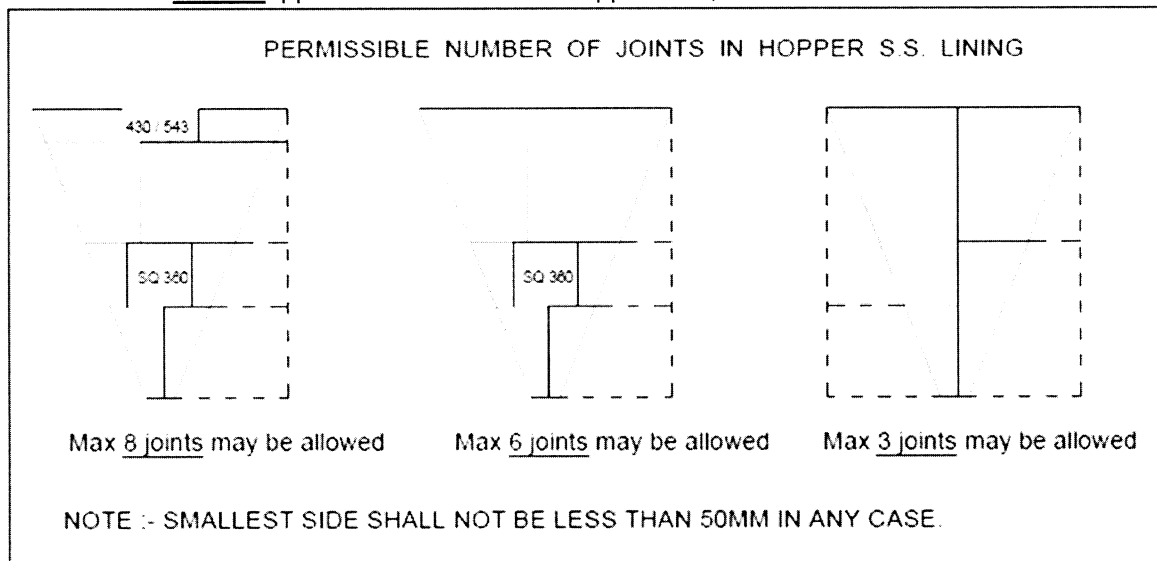

	QUALITY ASSURANCE	<i>QCP : E : 002</i>
	QUALITY CONTROL PROCEDURE FOR SPLICING NORMS FOR SHEETS / PLATES / STRUCTURALS APPLICABLE TO ESP COMPONENTS FABRICATION	<i>Rev. No. 03</i>
		<i>DT. 30.05.2013</i>

3.2 ANGLES, CHANNELS, BEAMS (BOTH ROLLED / BUILT UP - INCLUDING NPB&UB) APPLICABLE TO ESP ROOF BEAMS & SUPPORTING COLUMNS 7X-X28 and 7X-X81, 82, 83 & 84

- 3.2.1 The splicing norms for Angles, Channels and Beams (both rolled / built-up) shall be strictly followed as per the drawing no.1-79-081-02331 Rev.00.
- 3.2.2 Any change other than given in above referred drawing shall be approved by Engg (AQCS) and the request for the same shall be forwarded by cutting plan section of OS Dept.
- 3.2.3 Only one joint is permitted on the transverse roof beams.

3.3 “ H “ BEAMS APPLICABLE TO CASING STRUCTURE COLUMNS – 7X-X48 (BOTH ROLLED / BUILT UP)

- 3.3.1 The splicing norms for “H” Beams shall be strictly followed as per the drawing no. 4-79-000-00763 Rev.00.
- 3.3.2 Maximum two joints i.e., one for shop and another for site / field shall be permitted for a maximum length of 16.5 Mtr of section considering ODC constraints.
- 3.3.3 Joints on flange shall be staggered by minimum 300 mm avoiding falling of joint on the same side of the built up sections.
- 3.3.4 The splice plate provided for web joints shall not foul with the gusset plates provided on the “H” beams and a minimum clearance of 50 mm shall be maintained.
- 3.3.5 The minimum distance permissible between a joint and the nearest gusset / bracket location shall be 200mm.

3.4 RODS, ROUNDS, PIPS AND TUBES

- 3.4.1 No joint is permitted if the length of rod is 2 M or less.
- 3.4.2 Minimum length for splicing using sleeve shall be 500mm for tubes
- 3.4.3 Only one joint is permitted for Tie Rods / Strut

4.0 EDGE PREPARATION, WELDING, WELD NDE DETAILS :

- 4.1 Check for material specification of plates / sections which are to be joined to avoid mix up of material. TCN to be obtained for change of material.
- 4.2 Electrode selection shall be as per the respective WPS.

	QUALITY ASSURANCE	<i>QCP : E : 002</i>
	QUALITY CONTROL PROCEDURE FOR SPLICING NORMS FOR SHEETS / PLATES / STRUCTURALS APPLICABLE TO ESP COMPONENTS FABRICATION	<i>Rev. No. 03</i>
		<i>DT. 30.05.2013</i>

- 4.3 Welding shall be followed with suitable methods of sequence and controls to minimize the weld distortion.
- 4.4 Weld over joint shall be avoided and minimum distance between stiffeners parallel to weld joint is 50mm.
- 4.5 Wherever, back grinding is not feasible due to location of the plate / sheet, root welding to be carried out with 3.15mm electrode and LPI to be carried out after thorough cleaning and repeat LPI after final welding.
- 4.6 Following are the guidelines for Edge Preparation (EP) if not specified in drawing;
- a) **Plates / Sheets up to 5mm** : No EP required. Provide 2 to 3 mm root gap, weld on both sides. MPI to be conducted after final welding.
 - b) **Plates of 6 mm** : No EP required. Weld shall be with square butt with 2 to 3 mm gap. Weld from first side and turn the plate for back grinding and conduct root LPI. Complete the weld and conduct the final MPI.
 - c) **Plates of 7 & 8 mm** : Single "V" , 60° EP, Weld from V side and turn the plate, back grind and conduct LPI, complete the Weld. Final MPI.
 - d) **Plates above 8 mm** : Double "V" , 60° EP, Weld one side, Carryout back grind and conduct LPI to ensure sound metal and weld from other side. Final both side MPI after completion of weld.
 - e) **For Structural (Angle, Channel, Beam)** : Single "V" , 60° EP, Weld from V side and back grind and conduct LPI. Complete the weld, conduct final LPI before splice plate setting.

Note:

1. Splice plate details shall be taken from relevant fabrication Engg drawing.
2. Splice Joint shall be avoided where a cross member is meeting.
3. The weld should be ground flush and smooth and the proper splice plate is placed & welded.

!!!@@@###

QUALITY CONTROL PROCEDURE FOR SPLICING OF SHEETS,
PLATES AND OTHER STRUCTURAL ITEMS

SKETCH FOR CLAUSES 3.1.2 TO 3.1.4

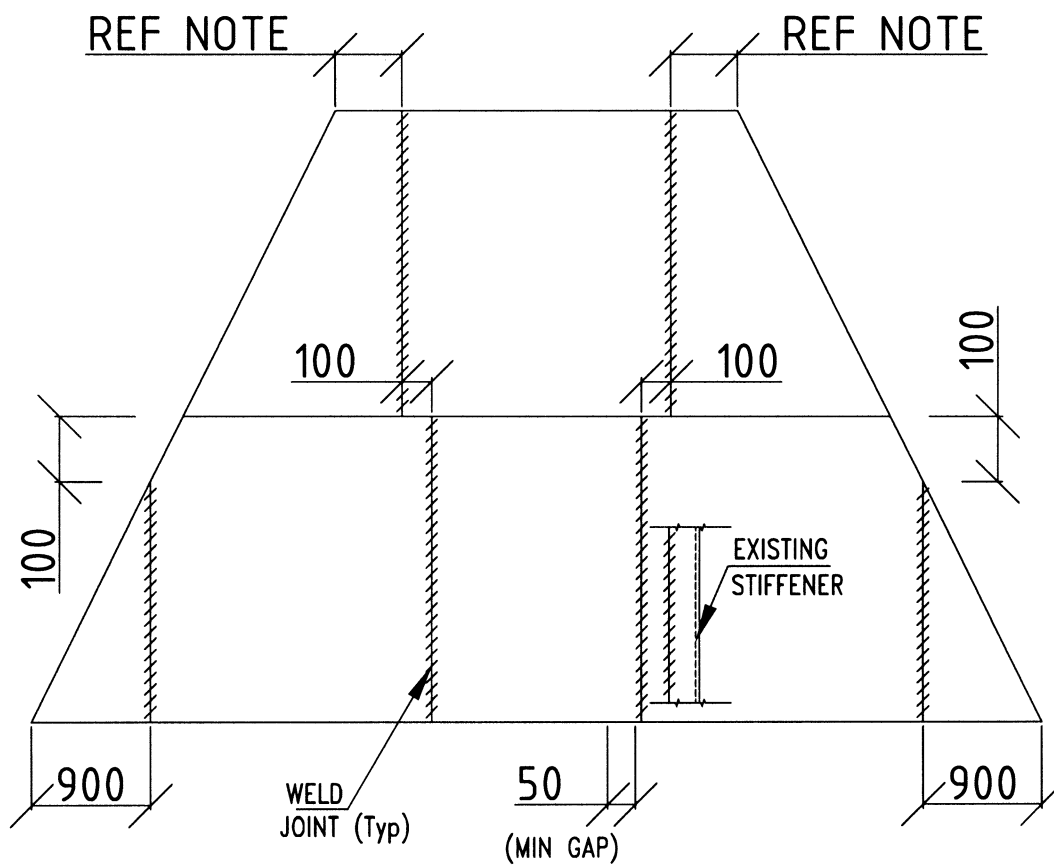

NOTE : MINIMUM DIMENSION OF SPLICED PLATE = 200 MM FOR
DUCT WALL OF ANY SIZE

ALL DIMENSIONS ARE IN MM



Ranipet

MANUFACTURER'S NAME & ADDRESS

BHARAT HEAVY ELECTRICALS LTD
BOILER AUXILIARIES PLANT
RANIPET-632 406 (INDIA)

STANDARD QUALITY PLAN

ITEM: ESP
Sub system: Sheet/Plate formed Components Shells,
Panels & Funnel Assy/Splitters, Hopper walls, GD housing
Panels.

QP NO

SQP: ESP: 284

REV NO



01

DATE

06 06 07

PAGE NO

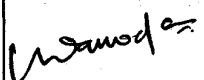
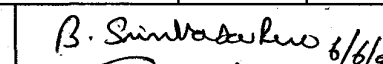
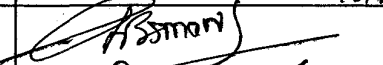
01 of 09

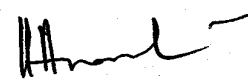
SI No	Component & operation	Characteristics	Type of Check	Quantum of Check	Reference Documents	Acceptance Norms	Format Of Records	Agency		Remarks
								M	B	
1	2	3	4	5	6	7	8	9	10	
1.0	Raw Material									
1.1	Sheets & Plates Rolled section, hollows, Tubes	Chemistry & Mechanical Properties	Chemical & tensile test	As per TDC		Respective TDC	TC	P	V	
2.0	In process control									
2.1	Flame cutting	Lamination and cracks	Visual	100%		As per AWS D1.1	R	P	V	
2.2	Joint 'V' Fit up for plates /Back gouging	Fitup Characteristics "V" Root gap, Land /weld soundness	-DO-	100%		AWS D1.1, Drawing and QCP E002 latest	R	P	V	
2.3	Welding	1) Procedure Qualification 2) Personal Qualification	Review of documents	100%		Prequalified welding procedure As per AWS D1.1	R	P	W	
			-DO-	-DO-		AWS D1.1	R	P	W	
LEGENDS:0 M - Manufacturer / Subcontractor, B - BHEL /BHEL Authorized Inspection Agency, P - perform, V - Verification of Reports W -Witness, TC - Test certificate, DR - Dimensional report,			 PREPARED BY	REVIEWED BY	QA QC-OLI ENGG	 6/6/07  	 APPROVED BY			



MANUFACTURER'S NAME & ADDRESS

BHARAT HEAVY ELECTRICALS LTD
BOILER AUXILIARIES PLANT
RANIPET-632 406 (INDIA)

STANDARD QUALITY PLAN

ITEM: **ESP**
Sub system: Sheet/Plate formed Components
Shells, Panels & Funnel Assy/Splitters, Hopper
walls, GD housing Panels.

QP NO :

SQP : ESP : 284

REV NO:

01

DATE

06 06 07

PAGE NO

02 of 09

Sl No 1	Component & operation 2	Characteristics 3	Type of Check 4	Quantum of Check 5	Reference Documents 6	Acceptance Norms 7	Format Of Records 8	Agency 9		Remarks 10
								M	B	
2.4	Weld insp									
2.4.1	Size and finish		VISUAL	-DO-	DRAWING AND SIP; NP;06		R	P	V	
2.5	Weld NDE									
2.5.1	But welds on soundness Structural joints	SOUNDESS	Visual & LPI	See Remarks*	ASW D 1.1		R	P	V	REMARKS*:- 1) Weld fitup 2) On all Primary stiffeners 100% LPI. On back gouged area 100% LPI. 3) 20% Random LPI on other joints @; In case of defects % shall be increased.
2.5.2	Fillet weld in structural	-DO-	LPI	10% Random @	-DO-		R	P	V	
3.0	Dimensional control						R	P	V	
3.1	Hopper walls	Length, width and diagonal straightness waviness, stiffener location and orientation	Measurement and visual	100%	Drawing		R	P	W	

LEGENDS:

M - Manufacturer / Subcontractor,
B - BHEL /BHEL Authorized Inspection Agency,
P - perform, V - Verification of Reports
W -Witness, TC - Test certificate,
DR - Dimensional report,

PREPARED BY

REVIEWED BY

QA

QC-OLI

ENGG

B. Srinivas Rao

P. Jayaprakash

Approved

APPROVED BY



MANUFACTURER'S NAME & ADDRESS

BHARAT HEAVY ELECTRICALS LTD
BOILER AUXILIARIES PLANT
RANIPET-632 406 (INDIA)

STANDARD QUALITY PLAN

ITEM: **ESP**
Sub system: Sheet/Plate formed Components Shells,
Panels & Funnel Assy/Splitters, Hopper walls, GD
housing Panels.

QP NO :

REV NO:

DATE

PAGE NO

SQP:ESP: 284

01

06 06 07

03 of 09

Sl No	Component & operation	Characteristics	Type of Check	Quantum of Check	Reference Documents	Acceptance Norms	Format Of Records	Agency		Remarks
								M	B	
1	2	3	4	5	6	7	8	9	10	
3.2	Roof panels	Position of support insulator, holes, length width, diagonals & straightness, waviness, stiffener location & orientation.	Measurement & visual	DO	DO		R	P	W	
3.3	Casing Shells	Length, width diagonal, straightness, waviness, stiffener location & orientation	DO	100%	DRAWING		R	P	W	
3.4	Top Panels	Length, width diagonal, straightness, waviness, stiffener location and orientation, hole size & location.	DO	100%	DRAWING		R	P	W	

LEGENDS:

M - Manufacturer / Subcontractor, B - BHEL /BHEL Authorized Inspection Agency,
P - perform, V - Verification of Reports
W Witness, TC - Test certificate,
DR - Dimensional report,

PREPARED BY

REVIEWED BY

QA

QC-OLI

ENGG

B. Sambasa Rao

[Signature]

P. Jayashankar

[Signature]

APPROVED BY



MANUFACTURER'S NAME & ADDRESS

STANDARD QUALITY PLAN

QP NO :

SQP : ESP : 284

REV NO:

01

BHARAT HEAVY ELECTRICALS LTD
BOILER AUXILIARIES PLANT
RANIPET-632 406 (INDIA)

ITEM: **ESP**
Sub system: Sheet/Plate formed Components Shells,
Panels & Funnel Assy/Splitters, Hopper walls, GD
housing Panels.

DATE

06 06 07

PAGE NO

04 of 09

Sl No 1	Component & operation 2	Characteristics 3.	Type of Check 4	Quantum of Check 5	Reference Documents 6	Acceptance Norms 7	Format Of Records 8	Agency		Remarks 10
								M	B	
								9		
3.5	Dimensional control contd... Vertical/horizontal splitters; shape	Slope, height location of flat with tacks	Measurement in layout	100%		Drawing	R	P	W	
3.6	Trial assy of hopper lower with heating chamber	Weld gap, overall dimn gap between hopper and heating chamber, matching of poke tube holes.	Measurement and visual	1(one) assy		DO	R	P	W	
3.7	Funnel assy									
3.7.1	Floor assy center line offset if any	Overall dimn length, width diagonal, taper, profile matching holes location ref	Visual measurement template for profile Match marking	100%		Drawing	R	P	W	

LEGENDS:

M - Manufacturer / Subcontractor,
B - BHEL /BHEL Authorized Inspection Agency,
P - perform, V - Verification of Reports
W -Witness, TC - Test certificate,
DR - Dimensional report,

PREPARED BY

REVIEWED BY

QA

QC-OLI

ENGG

B. Srinivas Rao

[Signature]

P. Lingappa

[Signature]

APPROVED BY



Ranipet

MANUFACTURER'S NAME & ADDRESS

BHARAT HEAVY ELECTRICALS LTD
BOILER AUXILIARIES PLANT
RANIPET-632 406 (INDIA)

STANDARD QUALITY PLAN

ITEM: **ESP**
Sub system: Sheet/Plate formed Components
Shells, Panels & Funnel Assy/Splitters, Hopper
walls, GD housing Panels.

QP NO :

SQP : ESP: 284

REV NO:

01

DATE

06 06 07

PAGE NO

05 of 09

Sl No 1	Component & operation 2	Characteristics 3	Type of Check 4	Quantum of Check 5	Reference Documents 6	Acceptance Norms 7	Format Of Records 8	Agency 9		Remarks 10
								M	B	
3.7.2	As a funnel assy flange dimns, level	Over all dimns. bottom/top openings height, diagonals of funnel, and orientation and alignment of corner end plates, verticality.	Visual measurement	100%		DO	R	P	W	
4.0	Final inspn: Surface cleaning, painting & preservation, marking	Welding, finish and appearance.	Visual	100%		Drawing, panting schedule PRQA 590(Latest)	R	P	W	

LEGENDS:

M - Manufacturer / Subcontractor,
B - BHEL /BHEL Authorized Inspection Agency,
P - perform, V - Verification of Reports
W -Witness, TC - Test certificate,
DR - Dimensional report,

[Signature]
PREPARED BY

REVIEWED BY

QA
QC-OLI
ENGG
[Signatures]

[Signature]
APPROVED BY

1.0 Note 1.0 GENERAL REQUIREMENT

- 1.1 Any additional requirement for a specific contract shall be referred separately.
- 1.2 Raw materials used shall confirm to the grades specified in the drawing &GMS.
- 1.3 Raw material shall be free from harmful visual defects like cracks, seams, laps, lamination, heavy pitting etc.
- 1.4 Fabricators shall check all the supplied raw materials for dimensions ,bend, camber etc. Straightening wherever necessary must be carried out before assy and welding.
- 1.5 Substitution of materials shall be done with the prior approval of EDC/AQCS.
- 1.6 Plates for flange shall be preferably machine gas cut. Cut edges shall be dressed smooth to remove all the undulations. Gas cut notches if any shall be filled up and dressed. The edges shall be straight and square.

Note: 2.0 INPROCESS CONTROL

- 2.1 The general requirements for process control during fabrication in QCP;002[Latest] read along with amendment 1.

Note:3.0 MARKING, CUTTING AND PREPARATION

- 3.1 Bottom level hopper lower part shall be flat and square and the same shall be assured during assembly.

Note: 4.0 WELDING REQUIREMENT & WELD INSPECTION

- 4.1 Splice joints shall be completed prior to the welding of cover plate.
- 4.2 Sequences of welding shall be so chosen as to minimize the distortion.
- 4.3 NDT as required shall be carried out on splice joints before cover plate welding.
 - 4.3.1 Visual inspection; after fabrication is completed, all welds shall be visually examined for arc strikes, sharp nicks, undercuts and size
- 4.4 Arc strike shall not be done straight on the job. Welder shall have a Separate piece for striking the arc
- 4.5 Welding procedure specification and welders qualification are detailed in SIP; NP;07[latest].
- 4.6 Butt welds in plate to make up the length shall be done carefully with suitable edge preparation. The stiffener angles & channels are to be welded to the casing shell only after completing all the splice joints and correcting weld distortions.
- 4.7 Splice joints if required, shall be in line with the following clauses.

- 4.8 Plates of 6 mm can be jointed using one of the following two alternatives;
- a) Single v preparation of 60-70 degree with 1-2 mm land and 2-3 mm gap Welding shall be done on the v side. Subsequently, the plates to be turned and backside cleaned by wire brush. Then 2nd side welding to be done. If this method of welding is adopted the inspectors hold point shall be joint fit up stage.
 - b) The plates can be jointed by keeping straight butt faces with a gap of 2-3 mm. Welding to be done from the first side. Subsequently, the back side to be fully gouged/ground and then welded. In this type, the inspectors hold Point shall be the stage after back gouging. The back gouging shall be checked visually.
- 4.9 5mm plates shall be joined by straight butt keeping a gap of 2-3mm. Inspectors may have surveillance on joint fit-up but no hold point is required.
- 4.10 In case of stiffener of small sections, used in casing shell, weld preparation may be single "v". Inspectors shall check the back gouging/grinding after first side welding.
- 4.11 Weld the "v" from the reversed side by a min of two layers.
- 4.12 The min strip to be used for weld joint shall be 500mm.
- 4.13 The distance between the nearest stiffener and the splice joint parallel to it shall be min. 50mm.

NUMBER OF JOINTS

<u>CASING SHELL AREA</u>		<u>MAX.NO OF VERTICAL JOINTS</u>
IN .M. sq		
Less than 4		-NIL-
Above	4 to 8	2
Above	8 to 12	3
Above	12 to 16	4
Above	16 to 20	5
Above	20 to 24	6
Above	24 to 30	8
Above	30	10

- 4.14 Wherever the horizontal joints are not in full length then those joints may be counted along with other vertical joints and the same may be allowed as follows.

<u>CASING SHELL AREA</u> in M sq	<u>MAX. NO. OF JOINTS</u>
Less than 2	-NIL-
Above 2-5	3
Above 5-10	5
Above 10-15	6
Above 15-20	8
Above 20-25	10
Above 25- 30	12
Above 30-32	14
Above 32	16

4.15 The joints shall be uniformly distributed throughout the casing shall be inline with above table.

Note: 5.0 FABRICATION TOLERANCES

Following tolerances shall be applicable on different dimensions of casing shells, roof panels, hopper walls.

- 5.1 Surface of finished casing shell /Hopper wall shall be flat. The manufactures shall take extra care while carrying out the welding and handling/turning the casing shell/hopper wall to avoid out of flatness or waviness. Maximum out of flatness or waviness, as checked by piano wire or straight edge shall not be more than 15mm(i. e. $\pm 7.5\text{mm}$).
- 5.2 Variation in liner dimensions shall not exceed plus or minus 1mm/Metere of nominal dimensions limited to
- Length 5mm
 - With 3mm
 - Diagonal difference 7mm (Max)
 - Out of straightness of the sides 3mm.
 - Out of squareness of flanges shall not exceed 2mm.
- 5.3 Hole size and pitch on the flange shall be strictly as per drawing. Hole size Variation shall be limited to +2mm variation in distance between hole centers shall not vary more than $\pm 2\text{mm}$.
- 5.3.1 Stiffener placement shall be with in $\pm 5\text{mm}$.
- 5.3.2 The disposition of dia 500mm hole with respect to the longitudinal center line of the panel shall be with in $\pm 3\text{mm}$.
- 5.3.3 Distance between the rectangular hole (for lifting tool) center of dia 400mm opening is $\pm 1.5\text{mm}$.
- 5.3.4 Diagonal difference of dia 400mm opening in middle roof panel (with two sets of Opening). 3mm max.

Note: 5.3.5 FABRICATION & DIMENSIONAL TOLERANCE OF SIDE PANELS AND MIDDLE PANNEL

5.3.5.1 FABRICATION

- 5.3.5.2 Butt welds in plate to make up the length shall be done carefully. All weld distortions shall be corrected before other stiffeners and Sections are welded to the plates.

5.3.5.3 TOLERANCE

- a) Length $\pm 3\text{mm}$
- b) Width $\pm 2\text{mm}$
- c) Distance between
guide pin $\pm 2\text{mm}$
- d) Diagonal difference $5\text{mm}(\text{Max})$
- e) Bottom panel walls – position of hole for collecting rapping shall be maintained with in $\pm 3\text{mm}$ from the bottom edge and the side of the panel. Similarly the position of cut-out for emitting rapping drive shall be with $\pm 3\text{mm}$ with respect to top and side of the panel.

Note; DIMENSIONAL TOLERANCE OF FUNNEL ASSY

- 5.3.5.4 Variation in liner dimensions of the funnel wall shall not exceed $\pm 1\text{mm}/\text{meter}$ of nominal dimensions limited to a maximum of 5mm.
- 5.3.5.5 Difference between diagonals shall not exceed 1mm/metre of approximate nominal diagonals length limited to max.of 7mm.
- 5.3.5.6 Out of squareness of flanges shall not exceed 1mm.
- 5.3.5.7 The level of the flanges is to be ensured by water level. The deviations Permitted is 2mm max.
- 5.3.5.8 The local out flatness allowed in individual panels is 5mm max. Flange holes, pitches of flange holes with in $\pm 1\text{mm}$.

Note: 6.0 Marking*

- 6.1 The following details shall be stenciled with white paint and the stenciled details covered with one coat of transparent varnish at the center of casing shell.
 - . Sub-Contractor code
 - . Work Order Number.
 - . DU Number.
 - . Weight
 - . Project
- 6.2 In addition of above stenciling , following details shall also be welded /punched and bordered in white paint.
 - . Sub-Contractor code
 - . Work Order Number.
 - . DU Number.

 <p>An ISO Company</p>	BHARAT HEAVY ELECTRICALS LIMITED (A Government of India Undertaking) பாரதமிகுமின் நிறுவனம்	Ph: 04172-284030, 284158,, 241170 Email: bsmanian@bhel.in ssvasan@bhel.in
	BOILER AUXILIARIES PLANT, Indira Gandhi Industrial Complex, RANIPET- 632 406 (Tamil Nadu)	

BHEL-BAP-OS- 54A ARC
SECTION – XI BANK GUARANTEE

(Instructions to Fill the Bank Guarantee Format to be issued by BHEL)

Minimum base BG value of Rs.5.00 Lakhs should be provided by the vendor at the time of signing the contract.

1. Bank Guarantee shall be issued by any one of BHEL's Bankers or any Nationalized Bank. Please refer to List of BHEL's Bankers enclosed.
 - a. If it is not possible, then BG can be issued by a Scheduled Commercial Bank with the prior approval of BHEL.
 - b. BG from Co-operative Banks is not acceptable.
2. Pre-printed BG Form of BHEL only shall be used. Should not retype the format.
 - a. Only the relevant information like Supplier Name, BG Value, Contract No., Validity etc. shall be typed in the pre-printed form and executed by Bank.
 - b. Special adhesive stamp of the required value shall be affixed on the 1st page of the Form.
 - c. If Special Adhesive stamps are not available, then applicable stamp duty shall be paid at the Bank / Agency nominated by the concerned State Government to collect stamp duty, who" will affix their signature, date and seal in the first page of the BG Form clearly marking it as "SPECIALADHESIVE" & "STAMP DUTY".
 - d. Stamp Duty for the BG shall be at the rate as applicable in the State where the BG is executed.
 - e. Bank seal shall be affixed on the special adhesive stamp.
3. The executing officer of the Bank shall indicate his name, designation and power of attorney number/signing power number etc. on the BG.
 - a. Any correction / overwriting on the BG shall be duly authenticated under the Seal and signature of the executing officer of the Bank.
 - b. Each page of the BG shall be duly signed/initialed by the executing officer of the Bank and the last page is to be signed with full particulars under the seal of the Bank.
 - c. Fax number, e-mail Address, contact person, phone number and complete postal address shall be indicated in the covering letter of the BG from Bank.
4. The validity of the BG shall cover a period of one year (or such other period as per purchase Order, if otherwise specified) from the last date of dispatch as per Purchase Order or actual date of last dispatch under the Purchase Order, whichever is later.

- a. The BG shall have a claim period of 3 months /1 year. If no separate claim period is indicated in the BG, then the validity shall be one year months (or such other period as per Purchase Order, if otherwise specified) plus 3 months / 1 year .
 - b. No clause of the BHEL BG Form shall be altered, deleted or new clauses added by the issuing Bank under any circumstances. Bank Guarantees with altered/deleted/added clauses will not be accepted by BHEL under any circumstances.
 - c. If the issuing bank wants to add any additional clauses, it shall be intimated to BHEL well in advance with exact text of clause, which shall be subject to approval by BHEL Law department. Those clauses specifically accepted by BHEL- Law department can be added in the last page of the BG form and executed by Bank.
5. Bank Guarantee shall be forwarded by issuing Bank directly to AGM(OS)/BHEL/BAP/Ranipet-632406.
- a. If it is not directly forwarded to BHEL due to unavoidable circumstance, then the issuing bank shall sent a letter directly to BHEL conforming the issue of the BG enclosing a photocopy of the original BG
 - b. The bank guarantee should not be routed through Bank along with other dispatch documents under any circumstances.
6. In case of any extension of BG the same shall be executed on non-judicial stamp paper of the required value.
- a. Only the due date and claim period shall be extended
 - b. The extension should not result in alteration of any material facts of the BG.
7. Bank Guarantees executed as per the above instruction only shall be accepted at our end. Hence kindly ensure compliance with the above instructions for yearly processing of the bills and to avoid hold up of the bills

SECTION XII

BANK GUARANTEE FOR SUPPLY FREE ISSUE MATERIAL

Bank Guarantee No:

Date:

NAME OF ISSUING BANK
& ADDRESSES OF THE BENEFICIARY
NAME OF ISSUING BANK
& ADDRESS
BANK EMAIL ID:
BANK PHONE NO:
SFMS Serial No* :
AUTHORISED SIGNATORIES CELL PHONE NO:
BANK FAX NO:
IFSC AND MICR CODE

Dear Sirs,

1. In consideration of Bharat Heavy Electricals Limited¹ (hereinafter referred to as the 'Employer' which expression shall unless repugnant to the context or meaning thereof, include its successors and permitted assigns) incorporated under the Companies Act, 1956 and having its registered office at _____¹ through its Unit at.....(name of the Unit) having awarded to.....² (Name of the Vendor / Contractor / Supplier) (**VENDOR CODE**), with its registered office at _____² (hereinafter called "the Vendor/Contractor/Supplier" which expression shall include its successors and permitted assigns) a contract Ref No.....dated³valued at Rs.....(Rupees -----) /FC.....(in words.....) for⁴(hereinafter called the 'Contract')

AND WHEREAS the Employer having agreed as per the terms and conditions of the Contract to supply free issue materials for the manufacture/fabrication of the equipment at the 'Contractor/Supplier/Fabricator's' site on furnishing of a Bank Guarantee for Rs. _____ (Rupees.....)⁵ in the manner hereinafter specified for the due safeguard of the free issue material,

2. we,, (hereinafter referred to as the Bank), having registered/Head office at and inter alia a branch at being the Guarantor under this Guarantee, hereby irrevocably and unconditionally undertake to forthwith and immediately pay to the Employer any sum or sums upto a maximum amount but not exceeding Rs ----- (Rupees -----) without any demur, merely on a demand from the Employer and without any reservation, protest and recourse and without the Employer needing to prove or demonstrate reasons for its such demand.

3. Any such demand made on the Bank shall be conclusive as regards the amount due and payable by the Bank under this guarantee. However, our liability under this guarantee shall be restricted to an amount not exceeding Rs. _____.

4. We undertake to pay to the Employer any money so demanded notwithstanding any dispute or disputes raised by the 'Contractor/Supplier/Fabricator in any suit or proceeding pending before any Court or Tribunal or Arbitrator or any other authority, our liability under this present being absolute and unequivocal.

5. The payment so made by us under this Guarantee shall be a valid discharge of our liability for payment hereunder and the 'Contractor/Supplier/Fabricator' shall have no claim against us for making such payment.

6. We theBank further agree that the guarantee herein contained shall remain in full force and effect during the period that would be taken for the performance of the said Contract and till the reconciliation of the free issue material has been carried out and that it shall continue to be enforceable till all the dues of the Employer under or by virtue of the said Contract have been fully paid and its claims satisfied or discharged.

7. We Bank further agree that the Employer shall have the fullest liberty without our consent and without affecting in any manner our obligations hereunder to vary any of the terms and conditions of the said

Contract or to extend time of performance by the said 'Contractor/Supplier/Fabricator' from time to time or to postpone for any time or from time to time any of the powers exercisable by the Employer against the said Contractor/Supplier/Fabricator and to forbear or enforce any of the terms and conditions relating to the said Contract and we shall not be relieved from our liability by reason of any such variation, or extension being granted to the said 'Contractor/Supplier/Fabricator' or for any forbearance, act or omission on the part of the Employer or any indulgence by the Employer to the said 'Contractor/Supplier/Fabricator' or by any such matter or thing whatsoever which under the law relating to sureties would but for this provision have effect of so relieving us.

8. The Bank also agrees that the Employer at its option shall be entitled to enforce this Guarantee against the Bank as a principal debtor, in the first instance without proceeding against the Contractor/Supplier/ Fabricator and notwithstanding any security or other guarantee that the Employer may have in relation to the Contractor's/Supplier's/ Fabricator's liabilities.

9. This Guarantee shall remain in force upto and including.....⁶ and shall be extended from time to time for such period as may be desired by Employer.

10. This Guarantee shall not be determined or affected by liquidation or winding up, dissolution or change of constitution or insolvency of the Contractor/ Supplier/ Fabricator but shall in all respects and for all purposes be binding and operative until payment of all money payable to the Employer in terms thereof.

11. Unless a demand or claim under this guarantee is made on us in writing on or before the **claim period last date** we shall be discharged from all liabilities under this guarantee thereafter.

12. Any claim or dispute arising under the terms of this document shall only be enforced or settled in the Courts at Ranipet.

We, BANK lastly undertake not to revoke this guarantee during its currency except with the previous consent of the Employer in writing.

Notwithstanding anything to the contrary contained hereinabove:

- a) The liability of the Bank under this Guarantee shall not exceed.....⁵
- b) This Guarantee shall be valid up to⁶
- c) Unless the Bank is served a written claim or demand on or before (minimum 3 to 6 months from the expiry date ⁷ all rights under this guarantee shall be forfeited and the Bank shall be relieved and discharged from all liabilities under this guarantee irrespective of whether or not the original bank guarantee is returned to the Bank.

13. We, _____ Bank, have power to issue this Guarantee under law and the undersigned as a duly authorized person has full powers to sign this Guarantee on behalf of the Bank.

For and on behalf of
(Name of the Bank)

Dated.....

Place of Issue.....

NAME AND ADDRESS OF THE EMPLOER. i.e Bharat Heavy Electricals Limited

¹ *NAME AND ADDRESS OF THE VENDOR /CONTRACTOR / SUPPLIER AND VENDOR CODE ASSIGNED BY BHEL . .*

² *DETAILS ABOUT THE NOTICE OF AWARD/CONTRACT REFERENCE*

³ *PROJECT/SUPPLY DETAILS AND CONTRACT VALUE*

⁴ *BG AMOUNT IN FIGURES AND WORDS*

⁵ *VALIDITY DATE (dd /mmm /yyyy)*

⁶ *DATE OF EXPIRY OF CLAIM PERIOD (dd /mmm /yyyy)*

* **Structured Financial Messaging System (SFMS)** has been/ is being implemented by the Banks as per the Ministry of Finance's instructions for Sending and receiving Bank Guarantee and also Inland Letter of Credit Instruments. The SFMS provides a platform for secure communication within the Bank and between Banks. As such, SFMS can prove to be an excellent IT enabled platform for getting secure confirmations from the Banks in respect of Bank Guarantees issued in favor of BHEL.

List of Consortium Banks

Sl. No	Nationalised Banks	Sl. No	Public Sector Banks
1	State Bank of India	18	IDBI
2	Allahabad bank		
3	Andhra bank	Sl. No	Private banks
4	Bank of Baroda	19	Axis Bank
5	Canara Bank	20	HDFC
6	Corporation bank	21	ICICI
7	Central bank	22	The Federal Bank Limited
8	Indian Bank	23	Kotak Mahindra Bank
9	Indian Oversea Bank	24	Indusind Bank
10	Oriental bank of Commerce	25	Yes Bank
11	Punjab National Bank		
12	Punjab & Sindh Bank	Sl. No	Foreign banks
13	Syndicate Bank	26	CITI Bank N.A
14	UCO Bank	27	Deutsche Bank AG
15	Union Bank of India	28	HSBC
16	United Bank of India	29	Standard Chartered Bank
17	Vijaya Bank	30	J P Morgan