

REV.	DATE	ALTERED	RAZVI	REV.	DATE	ALTERED		REV.	DATE	ALTERED	
03	30.7.02	CHECKED	G.S.N.M.RAO			CHECKED				CHECKED	
		APPROVED	T.M.R			APPROVED				APPROVED	

DRAWING REDRAWN ON AUTOCAD INCORPORATING EARLIER CHANGES NYLON RING I.D WAS NOT MENTIONED.

THE INFORMATION ON THIS DOCUMENT IS THE PROPERTY OF BHARAT HEAVY ELECTRICALS LIMITED. IT MUST NOT BE USED DIRECTLY OR INDIRECTLY IN ANY WAY DETRIMENTAL TO THE INTEREST OF THE COMPANY.

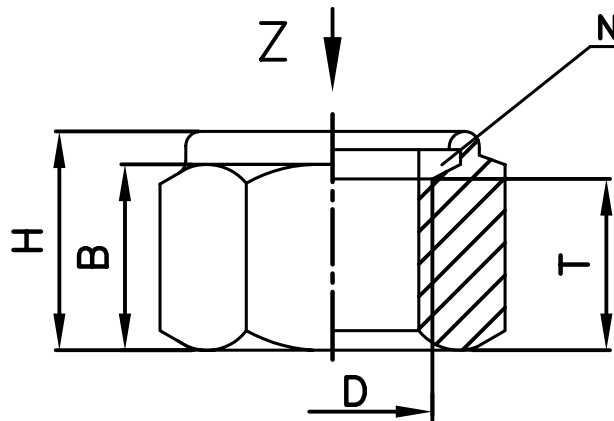

NYLON RING
(NYLON RING I.D SHALL BE EQUAL TO MINOR DIA -0.5 OF THREADING $+0.0$)

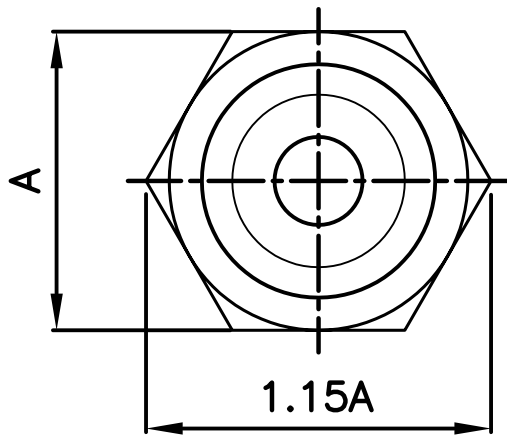

VIEW-Z

NOTE:

1. SURFACE TREATMENT WITH ZINC BICHROMATE
2. SAMPLE SHOULD BE APPROVED BY ENGG.
3. DIM TOLARANCE: IS 1364.-67 STD. PITCH,
4. MATERIAL: STEEL GRADE OF P8 CLASS.

NOMINAL DIAMETER-D	PITCH	A h 12	B MAX.	H h 14	T 0.8D	WT.IN KGS
27	3.00	41	26.0	30.8	21.6	0.182

COMPUTER NO.
46250393.DWG

DRG. NO.

REF. NO.

INVENTORY NO.

			BAN978103062	0.182	
				1	
DESCRIPTION & DRG.NO.	VAR NO.	RAW MATERIAL SIZE OR CASTING DRG.NO. OR FORGING DRG.NO.	MATL. CODE	NET.WT.	GROSS WT
			MATL. SPECN.	QTY.	

TYPE OF PRODUCT OR NAME OF CUSTOMER/PROJECT

BBD 4772/4760 TUBE MILL



भारत हेवी इलेक्ट्रिकल्स लिमिटेड
हैदराबाद
BHARAT HEAVY ELECTRICALS LTD.
HYDERABAD

	NAME	SIGN	DATE	NO.OF VAR.
DRN.	RAZVI		30.7.02	01
CKD.	G.S.N.M.RAO		30.7.02	
APPD.	T.M.R		30.7.02	

REF. TO HY0230. UNSPECIFIED TOL

DEPT. PULVE-EGG		SCALE 1:5	WEIGHT(K.G.) 0.182	REF.TO ASSY.DRG. 0-62-109-50721	ITEM NO. 14	NO.OF ITEM 39
CODE 4460	TITLE SELF LOCK NUT (WITH NYLON RING)			DRAWING NO. 4-62-108-50393		REV. 03
				SHT.NO. 01	NO.OF SHT. 01	