



**Bharat Heavy Electricals Ltd**  
**Electronics Division**  
**Mysore Road, Bangalore – 560 026**

**NOTICE INVITING TENDER**

1. TENDER NUMBER : 415/PRS/CE-Engg/mCR-FR/12/2
2. NAME OF WORK : Supply and installation of Stepped Platform, Acoustic Wall Paneling and False ceiling for the proposed training cum demo facility inside the factory premises
3. ESTIMATED COST : 27 Lakhs
4. EARNEST MONEY DEPOSIT : Rs. 60000/-
5. COMPLETION TIME : 45 DAYS
6. LAST DATE AND TIME FOR THE SUBMISSION OF DULY FILLED IN TENDER DOCUMENT : Before 13.00 Hrs. 17-08-2012
7. PLACE OF SUBMISSION OF TENDER DOCUMENT : in the tender box kept at reception area marked as FS&T., BHEL-Electronics Division Mysore Road, Bangalore - 560026
8. DATE AND TIME OF TECHNICAL BID OPENING : 13.30 Hrs. on 17-08-2012

NOTE: The tenderer shall return the duly filled in Tender document after **affixing Signatures on all pages and submit to;**

K.Venkateshalu  
Manager /Traction– CE-Engg  
BHEL-Electronics Division  
Mysore Road  
Bangalore – 560026  
Phone : 080-26998881  
eMail: venkateshalu@bheledn.co.in

CONTRACTOR

EMPLOYER

**Essential Criteria:**

1. Experience of having successfully completed similar works during last 7 years from the date of tender notice. Should satisfy any of the following similar completed works:
  - a. Three similar works each costing not less than an amount equal to 40% of estimated value mentioned against each work in tender notice.  
OR
  - b. Two similar works each costing not less than an amount equal to 50% of estimated value mentioned against each work in tender notice.  
OR
  - c. One similar works each costing not less than an amount equal to 100% of estimated value mentioned against each work in tender notice.
2. Latest bankers Solvency Certificate from Nationalized/Scheduled bank issued, not earlier than 12 months from the final date of tender submission for value not less than 10% of the estimated cost mentioned in the notice.
3. Average financial turn over during the last 3 years, ending 31<sup>st</sup> march of the previous financial year, should be 30% of the estimated cost as mentioned against each work in this notice.
4. *Mention the registration details / if registered with BHEL/CPWD/KPWD or any government or public sector organization.*

**Special conditions:**

- i) Successful bidder should have their business office/Branch office at Bangalore with adequate Administrative/Technical staff.
- ii) The Bidders should carry out a preliminary survey at proposed construction site before submission of offer to ensure the rate quoted for the relevant schedule of items are correct.
- iii) The Bidders should “furnish site inspection certificate”.
- iv) Bidders are required, to study prevailing market trends of construction materials/labours/other relevant requirement before submission of offer and submit competitive price.

**Note:** Offers of the tenderers not meeting the above requirements under are liable to be rejected.

Bharat Heavy Electricals Ltd  
Electronics Division  
Mysore Road, Bangalore – 560 026

## Tender Document

### For

Supply and installation of Stepped Platform, Acoustic Wall Paneling and False ceiling for the proposed training cum demo facility inside the factory premises

### Technical Bid

Date of opening: 13.30 Hrs. 17-08-2012

This Tender Document Contains total 43 Pages

Part – I	Technical cum commercial bid	2 Pages
	Instruction to tenderers	26 Pages
	Technical specification	05 pages <i>(Includes Drawings-3 Nos)</i>

Part – II Price Bid – 03 Pages

Note: Part – I: To be submitted in a separate sealed cover  
Part – II: To be submitted in a separate sealed cover

Earnest money deposit of Rs 60000/-to be submitted in a separate sealed cover.

Part-I, Part-II &EMD sealed covers should be put in outer envelope and super scribing the Name of work and Name & Address of the tenderer.

...

**TECHNICAL CUM  
COMMERCIAL BID**

**BHARAT HEAVY ELECTRICALS LIMITED,**  
**ELECTRONICS DIVISION**  
**MYSORE ROAD, BANGALORE-560026**

**PART-I - TECHNICAL-CUM-COMMERCIAL BID**

(Form to be filled & furnished by the Bidders)

1. NAME OF THE WORK : Supply and installation of Stepped platform, Acoustic Wall Paneling and False ceiling for the proposed training cum demo facility inside the factory premises

2. APPROXIMATE ESTT.COST Rs.: **Rs.27 lakhs**

3. STIPULATION PERIOD : **45 days**

4. NAME OF THE CONTRACTOR :

5. ADDRESS

a. OFFICE : .....

: .....

E-mail ID : .....

TEL.PH NO : .....

b. RESIDENCE : .....

: .....

TEL.PH NO : .....

QUALIFICATION : .....

6. STAFF STRENGTH

a. TECHNICAL : .....

b. GENERAL : .....

7. PLANT/EQUIPMENT : .....

8. a) SCOPE OF WORK : UNDERSTOOD/ NOT UNDERSTOOD  
(asper schedule of items)

b) ACCEPT TO EXECUTE IN TOTAL : YES/ NO

CONTRACTOR  
(With Seal)

Spec. No: DOC/TR/404/12/01/06

EMPLOYER

## 9. Documents in conformity to Essential criteria

S.N.	Check list	Yes/No/Details If any
9.1	Experience of having successfully completed similar work, as in essential criteria clause 1. Clearly indicate criteria a, b, c	
9.2	Banker solvency certificate for value in essential criteria clause 2 submitted. Indicate value.	
9.3	Average financial turn over during the last 3 years, ending 31st march of the previous financial year as per clause 3 of Essential criteria.	
9.4	Whether Registered with BHEL/KPWD/CPWD/MES/Railways/ other organisations. Specify the name of organisation, Indicate reg. no and validity of Registration.	Registered/Not registered/ Organisation / validity

## 10. Following documents are required to be submitted

10.1	Copy of PAN/GIR No. & Registration certificate issued by Income Tax authority.	
10.2	Certificate of TIN Number	
10.3	Service Tax Registration Certificate /details	Enclosed/not enclosed
10.4	Registration certificate with ESI / PF authority?	Yes/No
10.5	Whether agreeable to make necessary statutory payments as per BHEL EDN terms	Yes/No
10.6	Income tax Returns for last Three years.	
10.7	Bank statement of Last Six Months.	
10.8	Over draft facilities available with agencies	
10.9	Balance Sheet and profit and Loss Account for the last three years.	
10.10	Annual Turnover of last three years duly certified by the auditor.	
10.11	Details of works carried out during last 7 years in any Government/PSU/Large private Organization with certificate	
10.12	Plant and machinery details for the work.	
10.13	Work on Hand (Required for bid capacity also)	
10.14	Furnished site inspection certificate	
10.15	Site Office at Bangalore with Adequate technical and administrative staff.	
10.16	Availability of technical person	

11. EMD PARTICULARS :

a. CASH :

b. DEMAND DRAFT :

12. ACCEPTANCE

a. DRAWINGS :

b. DESIGNS :

b) VALIDITY OF REGISTRATION :

13. BHEL'S PAYMENT TERMS : WHETHER ACCEPTABLE / NOT

14. Electronic Fund Transfer(EFT)form enclosed : Please fill up the form

CONTRACTOR  
(With Seal)

Spec. No: DOC/TR/404/12/01/06

EMPLOYER

# **INSTRUCTIONS TO TENDERERS**

**Bharat Heavy Electricals Limited**  
**ELECTRONICS DIVISION**  
**MYSORE ROAD, BANGALORE - 560026.**

**INSTRUCTIONS TO TENDERER**

1. Sealed Tender for the above noted work is hereby invited from Contractors experienced in works of similar kind and magnitude.
2. Tenders should be addressed to the Manager (TRACTION), Electronics Division, Bharat Heavy Electricals Limited, Mysore road, Bangalore – 560 026 in two separate sealed cover for “Technical cum Commercial Bid” and Price Bid duly super-scribed and put in an outer envelope, super scribing the Name of Work and Name and Address of the Tenderer.
  - 2.1 The local address of the Contractors, the name of the person to whom all the correspondence are to be addressed should be indicated, with telephone number (both office and residence) and telephone numbers.
3. All entries in tender documents should be in one ink. Erasure and over writing are not permitted. All cancellation and insertion should be duly signed by tenderer concerned with proper indication of the name designation and address of the person signing.
4. Tenderer’s shall fill in all the required particular in the blank space provided for this purpose in the tender documents and also sign in each and every page of the tender document including the drawings attached there to before submitting tender.
5. Unit rate should be quoted in figures as well as in words in Indian Currency only i.e. Rupees and Paise with reference to each item and for the items shown in the attached schedule. These rates shall be for the finished work at site. The rate shall include all taxes and duties payable an account of Octroi, Sales Tax, tax on work contract etc., etc., and also expenses towards PF and ESI contributions (see clauses 8, 39 and Annexure ‘C’). Amount of each item and total on each sheet as also the grand total amount of the whole contract shall be filled by the tenderers.
6. In case the rate quoted in figures differs from those quoted in words, the lower of the rates will be taken as the tendered rate and shall be binding on the tenderer.
7. In quoting rates, the tenderer are advised to take into account all factors including any fluctuations in market rates. No claim for enhanced rates will be entertained on this account after acceptance of the tender or during the currency of the contract.
8. The rate to be quoted by the tenderer shall be firm and shall cover and include all statutory levies such as “Octroi, sales tax, excise duty etc., arising from Act passed by Parliament or State Legislature and rules framed there –under. The rates shall further be deemed to include statutory levies arising from such Acts, Central or State, which may come into force, subsequent to submission of tenders. The tenderer shall note that no claim for enhancement rates, on the ground that existing statutory levies have been increased or those new statutory levies have come into effect after tender, or on any other ground, will be entertained on any account.
9. a) The rate quoted in the tender shall remain valid for a period of ‘THREEMONTHS’ from the date of opening tender.

- b) Tenderer shall not increase their quoted rates, once the tenderer has submitted his quotation and during execution of contract in case his tender is accepted.
10. Quantities shown in the schedule are only approximate and are liable to variation without entitling the Contractors to any compensation, provided the total value of the contract does not vary by more than 20% (Twenty percent)
  11. Before tendering, the tenderers are advised to inspect the site of work and its environments and be well acquainted with the actual working and other prevailing conditions, position of material and labour. They should be well versed with BHEL General Conditions of Contract instruction to the tenderers, drawing and specification and all other documents which form part of the agreement to be entered into subsequent award of work. The tenderer should be specially note that it is tenderers responsibility to provide any items which is not specifically mentioned in the specifications and drawing, but which is necessary to complete the work.
  12. Details and quantities of each item of work shown in the bill of quantities attached here to only approximate. They are given as a guide for the purpose of tendering only and are liable for variation and alteration at the discretion of the competent authority. The work under each item as executed shall be measured and price at the corresponding rates to be quoted by the Contractor in the bill of quantities attached hereto.
  13. Should a tenderer find discrepancies or omission in the drawing attached to the tender documents or should be in doubt as to their meaning he should at once address to the authority inviting the tender for clarifications. Every endeavor is made to avoid any error which can materially affect the basis of the tender but successful tenderer shall take upon himself to provide for the risk of any error which may be subsequently discovered and shall make no subsequent claim on account thereof.
  14. In the event of the tender being submitted by a firm, the tender must be signed separately and legibly by each partner or member of the firm or in their absence, by the person holding the power of Attorney on behalf of firm concerned. In the latter case, a copy of the power of Attorney duly attested by the Gazetted Officer must accompany the tender.
  15. If in any case, the date of Tender Opening falls on holiday, the Tender will be opened on the next working day.
  16. Every tender must be accompanied by deposit receipt for the amount mentioned as Earnest Money Deposit. This earnest money will be refunded to the unsuccessful tenderer after finalization of the award of work. In the case of successful tenderer, the earnest money will be retained as a part of Security Deposit for satisfactory completion of the work in accordance with Clause-16 of BHEL General Conditions of the Contract. Tenders without Earnest Money Deposit receipt are liable to be rejected. No interest will be paid on the earnest money deposit.
  17. The Earnest money deposit may be furnished in any of the following forms:
    - Cash
    - Pay order.
    - Demand Draft in favour of BHEL EDN, Bangalore – 560026.
  18. Unless the contractor whose tender is accepted signs contract agreement within fifteen days (15 days) of the date of the order directing him to do so, the amount of Earnest Money already deposited by him may be forfeited and acceptance of the tender withdrawn.

19. If after opening of tenders a tenderer revokes his tender or increase his earlier quoted rates or after acceptance of his tender does not commence the work in accordance with the instruction of Engineer –in-charge, the Earnest Money Deposited by him will be forfeited and acceptance of his tender withdrawn. If only a part of work included in the tender had been awarded to the tenderer, the amount of Earnest Money to be forfeited will be based on value of the contract so awarded.
20. The BHARAT HEAVY ELECTRICALS LIMITED reserve the right to reject any or all the tenders received or accept any tender or part thereof without assigning reason thereof. In the case of acceptance of a part of tender, the time for completion may also be reduced to the extent considered approximately by the accepting authority.
21. Conditional and Unsigned tenders, tender containing absurd rates and amounts, tenders which are incomplete or otherwise considered defective, tenders which are not in accordance with the tender conditions laid down by the accepting officer and tenders not submitted in the prescribed forms are liable to be rejected.
22. The Contractors not borne on the approved list of Contractors of this organization must submit the following testimonials simultaneously with their tender super scribed. These testimonials shall be signed by the person(s) issuing the same indicating their name designation and full address  
.....  
.....
  1. A certificate to establish that the tenderer is an independent contractor working on his own.
  2. At least 2 certificate from the responsible Officer of Government or Firms of repute, regarding the tenderers capacity to undertake and carryout the work tendered for similar work satisfactorily.
  3. A certificate from the Bank of standing or magistrate regarding the tenderer financial position. Note: (a) Copies of testimonials unless attested by a Gazetted Officer will not be accepted. Non submission of the above testimonials simultaneously with the tenders may result in the tenders being rejected.
23. The tenders should be accomplished by a list of Contracts already held by the Contractor at the time of submitting the tender and giving the following particulars:
  - a. Name of the work, value and address.
  - b. The balance work remaining to be done on the same.
24. Tenders submitted by the post should be sent by “Registered Post with acknowledgement due”.
25. These should be posted with due consideration of any delay in postal delivery. Tenders received after the due date of opening tenders are liable to be rejected.
26. The Contractors responsibility under this contract shall commence from date of receipt of the order or acceptance of tender.
27. If tenderer expires after the submission of the tender or acceptance of his tender, the BHEL, may at their discretion cancel such tender. If a partner of a firm expires after the submission the tender, after the acceptance of tender, BHEL may cancel such tenders at their discretion unless the firm retains its character/s.
28. THE BHARAT HEAVY ELECTRICALS LIMITED will not be bound by any power of Attorney granted by the tenderer or changes in the composition firm made subsequent to

- execution of contract. They may however recognize such power of Attorney and changes after obtaining proper legal advice, the cost of which will be chargeable to the Contractor concerned.
29. If the tenderer deliberately gives wrong information on his tender, the BHEL reserves the right to reject such tender at any stage.
  30. Words imparting the singular number shall also be deemed to include the plural number and vice-versa where the context so require.
  31. The General and Special Conditions are complementary to each other and where they are in conflict, the special condition shall prevail.
  32. The expenses for completing the stamping agreement shall be paid by the contractor.
  33. Unless or otherwise stated above tendered work includes supply, erection, installation, testing and commissioning of equipment as agreed to in the contract.
  34. After completing of the job, the contractor has to furnish actual drawings of work done in consultation with Engineer-in-charge.
  35. Any covering letter and comments of the Contractor should be submitted in duplicate along with the offer.
  36. Cement for carrying out Civil Works and arising out of erection work will be supplied by Contractor.
  37. The Contractor shall provide all the materials needed for trial run, testing including chemicals, consumables etc. In quoting their rates, the Contractors are advised to take into account the cost of the above materials.
  38. Should a tenderer or a contractor on the list of approved contractors has a relative or in the case of firm or Company of Contractors any of its shareholders relative is employed in a Gazetted Capacity in the Electronics Division of Bharat Heavy Electricals Limited, Banalore-26, the authority inviting tenders shall be informed of this fact at the time of submission of the tender, failing which tender may be disqualified or if such fact subsequently come to light, the relevant provisions of the General Conditions of Contract will apply.
  39. These 'INSTRUCTIONS TO TENDERERS' & GENERAL CONDITIONS OF CONTRACT OF BHEL' shall be deemed to form an integral part of the Contract agreement for the work to be entered into. In cases of variation between the two in any matter, the conditions in the 'THE INSTRUCTIONS TO TENDERERS' shall prevail. Extracts of some of the important clauses of BHEL G.C.C. are enclosed (Annexure containing extracts of clauses 20, 38 and 58 of BHEL G.C.C). The Contractor has to obtain, at his cost, a copy of the BHE: GCC, Scrutinize the same, and when submitting his tender, indicate his acceptance of BHEL GCC.
  40. All operations to be carried out by the Contractor during the execution of the contract such as drilling, welding etc., shall be done with proper equipment to be brought by the tenderer. Suitable power point will be provided and tapping from the power point equipment shall be done using proper size of cables equipment and after getting approval of connections from our Engineer-in-charge.

41. The Contractor shall comply with the provision of Employees Provident Fund's and miscellaneous Provisions Act 1952 and rules, regulations and other orders issued there under. He as an employer shall be liable to pay employer's contribution/deductions towards PF under the PF Act in respect of all labour employed by him for the execution of the contract in accordance with the provisions of the Employees' Provident Funds and Miscellaneous Provisions Act, 1952 as amended from time to time. For this purpose he shall indicate the code number obtained from the Regional Provident Fund Commissioner or he should obtain a code number if he has not and produce the Photostat copy of the challanreceipt of monthly remittance of the contribution made by him to the Commissioner. Final payments due to him will be released only on production of a "No due certificate" from the Regional Provident Fund Commissioner. He shall also furnish such returns such returns as are due, under the Act, to be sent to the appropriate authorities through the Principal Employer".
42. The Contractor should get himself registered with the E.S.I Authorities as an independent Employer, obtain a separate code number and remit the dues in respect of the Labour employed by him for the work and produce the challans/Receipts of remittance of the ESI contributions due under the E.S.I Act to the Company authorities. He shall also furnish such returns, as are due, under the Act, to be sent to the appropriate authorities' through the Principal Employer.
  - 42.1. If any action is brought in by P.F.Commissioner/ESI authorities on BHEL for the work done by the Contractor for his labourers' regarding PF/ESI amount due, short remittances, non-remittances etc., the Contractor shall defends the case on behalf of BHEL and / or reimburse BHEL the expenses so incurred.
  - 42.2. The Contractor shall apply and obtain license under Contract labour(R&A) Act 1970 and comply the relevant provisions of this Act in respect of the labour employed by him for executing this contract. The contractor shall furnish necessary returns to the authority through the Principal Employer.
43. Contractor shall insure all his labourers' and material. Any claim by his Employees for damages shall be settled by the Contractor even if action is against BHEL or to reimburse the legal expenses incurred by BHEL.
44. Any action brought in by anybody on BHEL regarding patent, right etc., used by Contractor in execution of work shall be defended by the Contractor and / or reimburse BHEL the cost of the same.
45. Contractor shall produce necessary records, documents, explanation whenever he is called upon to do by any Government Agencies like ESI, PF, VIGILANCE etc.,

**BHARAT HEAVY ELECTRICALS LIMITED**  
**(ELECTRONICS DIVISION)**  
**MYSORE ROAD, BANGALORE-560 026**

**GENERAL CONDITIONS OF CONTRACTS/TECHNICAL SPECIFICATIONS**

It is hereby agreed by me/us that the BHEL General Conditions of Contract including subsequent amendments/ additions/deletions to clauses if any, and conditions pertaining the settlement of disputes by Arbitration form an integral part of the tender documents and that the tender submitted by me/ us is subject to the aforesaid BHEL General Conditions of Contract and BHEL-EDN Technical Specifications for Civil works which has been read and accepted by me/us.

CONTRACTOR  
(With Seal)

Spec. No: DOC/TR/404/12/01/06

EMPLOYER

## ANNEXURE 'C'

## CLAUSE 20 OF GENERAL CONDITIONS OF CONTRACT LABOUR

The Contractor shall employ labour in sufficient numbers either directly or through sub-contractors to maintain the required date of progress and of quality to ensure workmanship of the degree specified in the contract and to the satisfaction of the Engineer-in-charge. The contractor shall not employ in connection with the works any person who has not completed his eighteen years of age.

The contractor shall furnish to the Engineer-in-charge at the intervals specified by him, a distribution return of the number and description by trades of the work people employed on the works. The Contractor shall also submit on the 4<sup>th</sup> and 19<sup>th</sup> or every month to the Engineer-in-charge a true statement showing in respect of the second half of the preceding month and the first half of the current month (I) the accidents that occurred during the said fortnight showing the circumstances under which they happened and the extent of damage and injury caused by them and (ii) the number of female workers who have been allowed maternity benefits as provided in the maternity benefit Act, 1961 or Rules made there under and the amount paid to them.

The contractor shall pay to labour employed by him either directly or through sub-contractors wages not less than fair wages as defined in the contractors Labour Regulations.

The Contractor shall in respect of labour employed by him either directly or through sub-Contractors complies with or causes to be complied with contractors labour Regulations in regard to all matters provided therein.

The Contractors shall comply with the provisions of the payment of wages Act, 1936, Minimum Wages Act, 1948, Workmen's Compensation Act 1923, Industrial Disputes Act, 1947, Maternity Benefit Act 1961 or any modifications thereof or any other law relating there to, and rules made there under from time to time.

The Contractors shall be liable to pay his contribution and the employees' contribution of the State Insurance Scheme in respect of all labour employed by him for the execution of the contract, in accordance with the provision of "The Employees', State Insurance Act, 1948", as amended from time to time. The Contractors shall apply to the ESI Authorities, get himself registered with them and obtain a code Number. He shall pay the remittances under his code Number only.

The Contractor shall be liable to pay his contribution and the Employees' contribution towards PF as per Provident Fund Rules and Regulations in respect of all labour employed by him for the execution of the contract. The contractor shall apply to the PF Authorities, get himself registered and obtain a code number from them. He shall pay the remittances towards PF under his code Number only.

The Engineer-in -charge shall on a report having been made by an Inspecting Officer as defined in the Contractors Labour Regulations have the power to deduct from the moneys due to the Contractor any sum required or estimated to be required for making good the loss suffered by a worker or workers by reason of non-fulfillment of the conditions of the contract for the benefit of workers, non - payment of wages or of deductions made from him or their wages which are not justified by the terms of the contract of non-observance of the said contractor's Labour Regulations.

CONTRACTOR  
(With Seal)

Spec. No: DOC/TR/404/12/01/06

EMPLOYER

The Contractors shall indemnify the BHEL against any payment to be made under and for observance of the Regulation aforesaid without prejudice to his right to claim indemnity from these sub-contractors.

In the event of the contractor committing a default or breach of any of the provisions of the aforesaid contractors Labour Regulations, as amended from time to time or furnishing any information or submitting or filling any form/Register/Slip under the provisions of these Regulations which is materially incorrect then on the report of the Inspecting Officers as defined in the Contractors Labour Regulations, the contractor shall without prejudice to any other liability pay to the BHEL a sum not exceeding Rs.50/- as liquidated damages for every default breach or furnishing, making, submitting, filling materially incorrect statement as may be fixed by the Engineer-in-charge and in the event of the contractor's default continuing in this respect, the liquidated damages may be enhanced to Rs.50/- per day for each day of default subject to maximum percent of the estimated cost of works put to tender . The contractor shall defend the case by himself any action brought in by such Government Agencies for non-compliance of any Labour Regulations and / or reimburse the expense incurred by BHEL in this regard.

The Engineer –in-charge shall deduct such amount from bills or security deposit of the contractor and credit the same to the welfare fund constituted under Regulations. The decisions of the Engineer-in-charge in this respect shall be final and binding.

#### MODEL RULES FOR LABOUR WELFARE

The Contractor shall at his own expense comply with or cause to be complied with model Rules for Labour Welfare as appended to these conditions or rules framed by Government from time to time for the protection of health and for making sanitary arrangements for workers employed directly or indirectly on the works, In case the Contractors fails to make arrangements as aforesaid the engineer-in-charge shall be entitled do so and recover the cost thereof from the contractor.

**SAFETY CODERESPONSIBILITIES OF THE CONTRACTOR IN RESPECT OF SAFETY OF MEN, EQUIPMENT, MATERIAL AND ENVIRONMENT**

1. Before commencing the work, contractor has to submit a “SAFETY PLAN” to the authorized BHEL Official. The ‘SAFETY PLAN’ shall indicate in detail the measure that would be taken by the contractor to ensure safety of men, equipment, material and environment during execution of the work. The plan shall take care to satisfy all requirements specified hereunder. The contractor shall submit Safety Plan along with his offer. During negotiations before placing of work order and during execution of the contract BHEL shall have right to review and suggest modification in the Safety Plan. Contractor shall abide by BHEL decision in this respect.
2. The contractor shall take all necessary safety precautions and arrange for appropriate appliances as per direction of BHEL or its authorized officials to prevent loss of human lives, injuries to personnel engaged, and damage to property and environment.
3. The contractor shall provide to its work force and ensure the use of the following personal protective equipment as found necessary and as directed by the authorized BHEL officials: -
  - (i) Safety Helmets conforming to IS-2925: 1984.
  - (ii) Safety Belts conforming to IS-3521: 1983.
  - (iii) Safety Shoes conforming to IS-1989: 1978.
  - (iv) Eye and Face protection devices conforming to IS-8520: 1977 and IS-8940: 1978.
  - (v) Hand and body protection devices conforming to:  
IS-2573: 1975  
IS-6994: 1973  
IS-8807: 1978  
IS-8519: 1977
4. All tools, tackles, lifting appliances, material handling equipment scaffolds, cradles, safety nets, ladders, equipment’s etc. used by the contractor shall be of safe design and construction. These shall be tested and certificate of fitness obtained before putting them to use and from time to time as instructed by authorized BHEL official who shall have the right to ban the use of any item.
5. All electrical equipment’s, connections and wiring for constructions power, its distribution and use shall conform to the requirement of the Indian Electricity Act and Rules. Only electricians licensed by the appropriate statutory authority shall be employed by the contractor to carry out all types of electrical works. All electrical appliances including portable electric tools used by the contractor shall have safe plugging system to source of power and be appropriately earthed. The contractor shall not use any hand lamp energized by electric power with supply voltage of more than 24 volts. For work in confined space lighting shall be arranged with power sources of not more than 24 volts.
6. The Contractor shall adopt all fire safety measures as laid down in the “Code for fire Safety at Construction Sites” issued by the Safety Department of the Construction Management (HQ) of BHEL and as per directions of the authorized BHEL official. A copy of the above referred

CONTRACTOR  
(With Seal)

Spec. No: DOC/TR/404/12/01/06

EMPLOYER

“Code of Fire Safety at the Construction Sites” shall be made available by BHEL to the contractor for reference, on demand by the contractor, during tendering stage itself.

Where it becomes necessary to provide and/or store petroleum Products, explosives, chemicals and liquid or gaseous fuel or any other substance that may cause fire or explosion, the contractor shall be responsible for carrying out such provisions and/or storage in accordance with the rules and regulations laid down in the relevant government acts, such as Petroleum Act, Explosives Act, Petroleum and Carbides of Calcium Manual of the Chief Controller of Explosives, Govt. of India. etc., prior approval to the authorized BHEL official at the site shall also be taken by the contractor in all such matters.

7. The contractor shall arrange at his cost (wherever not specified) appropriate illumination at all work spots for safe working when natural daylight may not be adequate for clear visibility. The contractor shall be held responsible for any violation of statutory regulations local, state or central and BHEL instructions, that may endanger safety of men, equipment, material and environment in his scope of work or another contractor's or agencies. Cost of damages if any, to life and property arising out of such violation of statutory regulations and BHEL instructions shall be borne by the contractor.
8. In case of a fatal or disabling injury accident to any person at construction sites due to the lapses by the contractor, the victim and/or his/her dependents shall be compensated by the contractor as per statutory requirements. However, if considered necessary, BHEL shall have the right to impose appropriate financial penalty on the contractor and recover the same from payments due to the contractor for suitably compensating the victim and/or his/her dependents. Before imposing any such penalty, appropriate enquiry shall be held by BHEL giving opportunity to the contractor to present his case.
9. In case of any damage to property by the contractor, BHEL shall have the right to recover cost of such damages from payments from payments due to the contractor after holding an appropriate enquiry.
10. In case of any delay in the completion of a job due to mishaps attributable to lapses buy the contractor; BHEL shall have to recover cost of such delay from payments due to the contractor, after notifying suitably and giving him opportunity to present his case. If the contractor fails to improve the standards of safety in its operation to the satisfaction of BHEL after being given a reasonable opportunity to do so; and/or if the contractor fails to take appropriate safety precautions or to provide necessary safety devices and equipment or to carry out instructions regarding safety issued by the authorized BHEL official, BHEL shall have the right to take corrective steps at the risk and cost of the contractor after giving a notice of not less than seven days indicating the steps that would be taken by BHEL. The contractor shall submit report of all accidents, fires and property damage, dangerous occurrence to the authorized BHEL official immediately after such occurrence, but in any case not later than twelve hours of the occurrence. Such reports shall be furnished in the manner prescribed by BHEL. In addition, the contractor to the authorized BHEL official shall also submit periodic reports on safety from time to time as prescribed.

11. Before commencing the work, the contractor shall appoint/nominate a responsible officer to supervise implementation of all safety measures and liaison with his counterpart of BHEL. If safety record of the contractor in execution of the awarded job is to the satisfaction of Safety Department of BHEL, issue of an appropriate certificate to recognize the safety performance of the contractor may be considered by BHEL after completion the job.

**ANNEXURE 'D'**  
**CLAUSE 38 OF BHEL GENERAL CONDITIONS OF CONTRACT**

**INSURANCE OF WORKS AGAINST DAMAGE AND LOSS DUE TO FIRE, STRIKE,  
TEMPEST, FLOODS, EARTHQUAKE, RIOT AND AGAINST DAMAGE BY AIRCRAFT**

1. The Contractor shall, within one month after the date of acceptance of the contract, insure the work against loss and damage by fire, tempest, floods, earthquake, riots, and strike & against damage by air-craft with an insurance office approved by the Accepting officer from the date of acceptance of work or actual commencement of work whichever is earlier. Such insurance shall be effected in the name of BHEL and shall be for the full value of the contract sum. The contractor shall lodge with the BHEL the policies and receipts of the premiums for such insurance and shall maintain such policies in force until the entire completion of the work as certified by the Senior Engineer.  
If the contractor fails to comply with the terms of this condition the Accepting Officer may insure the work and may deduct. The amount of premium from any money that may become payable to the contractor or may at his discretion refuse payment of any advance to the contractor until the contractor shall have complied with the terms of this condition.
  
2. Such insurance whether effected by the Accepting Officer or the Contractor shall not be a limit or bar to the liability and obligation of the contractor to complete the entire work in all respects as certified by the Senior Engineer.  
In case of such a loss or damage as aforesaid, the money payable under any such insurance shall be received and may be retained by the BHEL until the work is finally completed and shall then be credited to the contractor in the final statement of accounts in the event of the contract not having been previously cancelled under these conditions after taking into account the delay in completion, settlement to his workers for damages, damage to BHEL property etc.

CONTRACTOR  
(With Seal)

Spec. No: DOC/TR/404/12/01/06

EMPLOYER

## **SPECIAL CONDITONS OF CONTRACT**

### **1. GENERAL**

The special conditions of contract and other contract documents are complimentary to each other and shall be read in conjunction with each other. In case of any conflict of meanings between the special conditions of contract and the BHEL General Conditions of Contract the provisions of the special conditions of contract shall override the corresponding provisions of the BHEL General Conditions of Contract.

### **2. SCOPE OF WORK**

The scope of work includes for the full, final and entire completion of all works as detailed in specifications and drawings, which forms part of this Contract. The scope of work also includes cleaning/removing all debris resulting from the contract as stipulated in the item schedule as per direction of the Engineer-in-charge.

The scope of work under this contract shall cover supply of all materials, labour, tools, and plants etc., unless otherwise specified in the specifications, descriptions of items or in foregoing clauses.

### **3. SITE CONDITIONS**

a) Before tendering the Contractor shall get himself/themselves acquainted with site conditions. The rates quoted by the contractor shall be deemed to have been quoted after getting acquainted with the prevailing site conditions.

b) The site of work is as mentioned in the Tender document.

### **4. SITE FACILITES: -**

#### **4.1. LAND: -**

The Employer will allot land as available free of cost to the contractor for his office stores. He must maintain the areas allotted to him in a neat and clean conditions as required by the Employer. The contractor shall provide adequate storage and office facilities with approval from the Engineer. The rate quoted by the contractor shall be deemed to include for these and no separate payment will be made towards these.

On completion of work, the site shall be cleaned by the contractor of all materials, temporary debris, rubbish plants and equipment's, belonging to the contractor at no extra cost. The site and surroundings shall be handed over in neat and clean conditions. In case of any failure by the contractor, the employer will get inside cleared at risk and cost of the Contractor

#### **4.2. POWER AND WATER SUPPLY**

Subject to availability water and electricity for the work may be provided by BHEL at one point and the contractor will have to make further arrangements for utilizing the supply from other points if required cost there of shall be recovered from the contractors from the bills due to them at the prevailing cost rates worked out by BHEL. At present, the cost rates of recovery by BHEL are Rs.15.00/- per1000 liters of water and Rs.5.90 per unit of Electricity. BHEL is not responsible for any failure of water/electricity supply and the contractor will have to make his own arrangements for the same, without claiming any extra rate.

CONTRACTOR  
(With Seal)

Spec. No: DOC/TR/404/12/01/06

EMPLOYER

#### **4.3. MACHINERY**

The Contractor shall at his own expense, supply all tools, plant and equipment (hereinafter referred to as T & P) required for execution of contract, as specified in the tender documents.

No. P.O.L. can be supplied by the Employer.

5. a) The whole of the works shall be executed in perfect conformity with the specifications and drawings. If contractor perform any works in a manner contrary to the specifications and drawings and without reference to the Engineer he shall bear all the costs arising or ensuring there from.
- b) All technical documents regarding the construction of works are given in the metric system and work should be carried out according to metric system.
- c) The work shall be carried out as per detailed drawings supplied by the employer. Only two copies of the working drawings shall be supplied progressively to the contractor free of cost. The contractor shall keep one set of drawings fully cloth back at his own expenses always available at site for reference of Engineer-in-charge and other representatives.  
In case the contractor desires to obtain additional copies of drawings, the same shall be supplied by the Employer on payment of charges as fixed by the Engineer-in-charge.
- d) The works shall be carried out as per detailed specifications enclosed with the tender. For items for which there is no mention in the drawings, detailed specification relevant IS specification (latest edition) shall be followed.
- e) The contractor shall submit to the Employer for their approval complete drawings, of all temporary works and staging which he may require for carrying out the works shown in the drawings. He shall at the same time if so required by the Employer submit his calculations relating to strength and anticipated deflection in respect of any aforesaid temporary works. He shall also submit for the approval of Employer drawings showing the methods he proposes to adopt for the erection of the various parts of the temporary works. Any modification to the drawings that may be required by the Employer shall be made by the contractor at his own cost. However, notwithstanding the approval of modification required for temporary works, the contractor shall be fully responsible for their efficiency, security and maintenance and for all obligations and risks in regard to such works, specified or implied in this contract and he shall reinstate the same at his own cost, should any mishap or accident occur causing damage or injury there from, subject however, to such clauses of the General conditions as may be applicable in such cases

#### **6. BENCH MARKS AND REFERENCE POINTS**

The contractor shall construct and maintain proper benchmarks and reference points of the inter section of all main walls, no separate payment shall be made for this and rates quoted deemed to include this cost.

#### **7. SAFETY PRECAUTIONS**

The contractor shall at times observe the safety code enclosed and make necessary action as required in the tender. In default thereof, the employer may get this done departmentally or through other agencies and recover the cost from the contractor. The Contractors shall also abide by all the security regulations promulgated from time to time by employer.

**8. RATES**

The rates to be quoted are intended to provide for works duly and properly completed in accorded with the general and special conditions of contract and specifications and drawings together with such alteration and or conditions as may be required / ordered without prejudice to the generality thereof shall include for detail of construction which are obviously and fairly intended and which may not have been specifically referred in these documents and working drawings and but are essential for execution and satisfactory completion of work including those of minor nature and shall be deemed to include and cover internal the followings.

- a. The cost of all superintendence and labour materials, tools, plants, equipment's, mobilizing and demobilizing equipment fuel lubricants, fixture, transport charges, temporary and permanent works and quarrying charges, testing, screening, washing, handling of materials, stacking and removal charges, of any rejected materials and water and power arrangements and satisfactory maintenance of the same satisfactory completion of the work intended.
- b. All fees, duties, royalties, rent and compensation to owner for surface damage or taxes And impositions payable to local authorities, in respect of land an structure, for all materials supplied for the work or any other duties/expenses for which the contractor may become liable or may be put to under any provision of the law for the purpose of in connection with the execution of the contract including revise payable on the transactions.
- c. Watching and lighting arrangements as required for satisfactory performances.
- d. Settings out of works profiles etc., and of construction repair and up-keep of all center lines, bench marks and levels and page there of including provisions of masonry/concrete pillars showing the center line of structure/gridlines and levels and maintenance and protection of the some including providing fencing etc., throughout the period of contract.
- e. Breaking, maintenance and removal of temporary works and buildings.  
Supply of complete, Moulds, cost of testing of materials etc.  
Unless otherwise specified in the specification schedule cost of all loads.
- f. All materials and labour required for fencing in a protection against risk of accidents and for providing necessary/planking strutting with hand rails, gumboots, helmets, safety belts etc., during the progress of work.
- g. All prevention on compensation for tress passes of barrier arrangements for the safety of the public or employees during the provision of works.
- h. Works in all shapes inclined or curved and all sizes as shown or as are required.
- i. Cleaning the site after the completion of work of all debris, left out construction materials, machine equipment's, temporary offices, stores, work shop etc., including micro dressing the area in neat and clean shape.
- j. Such other incidental charges or contingencies as may have been provided for in the specifications.

**9. LABOUR COLONIES: -**

No labour camps will under any circumstances be permitted within the premises.

**10. ESCALATION: -**

The rates to be quoted by the tenderer shall be firm and shall cover and include all statutory levies, arising from, acts passed by parliament or by state legislature, the rates shall further be deemed to include statutory levies arising from such Acts, Central or State, which may come in to force subsequent to submission of tenders. The tenderer shall note that no claim for enhancement of rates, on the ground that existing statutory levies have been increased or those new statutory levies have come in to effect after tender, or on any other ground, will be entertained on any account.

**11. LEAD, LIFT, DEWATERING ETC..**

Unless otherwise specified in the tender schedule, the rates for all items will be deemed to include all leads, lifts and descents involved in the work.

No separate payment will be made for dewatering (including seepage, surface drainage and monsoon water) dislodging and allied operations at any stage of the work, and the cost of such operations will be deemed to be included in the contract rates

No separate payment will be made for curing including pumping of curing water where necessary.

**12. EXTRA ITEMS**

No extra items of work shall be carried out by the contractor other than those authorized to do so in writing by the Engineer. For any such items of work executed as per instructions of Engineer. The rates will be fixed on the basis indicated under clause 50 of BHEL GCC.

The schedule of rates to be followed in this case will be CPWD schedule of rates.

**13. Quantity**

The probable quantities of the several items of work are furnished in the schedule of quantities. It must be clearly understood that neither the probable quantities nor the value of individual items nor the aggregate value of the entire work shall be binding on the Employer/Engineer does not in any way assure the contractor or Guarantee that the said probable quantities are correct or that the work will correspond to these. The Employer/Engineer reserve the right to omit, vary or add to the item/work described in the schedule, of quantities and no claim for compensation will be entertaining on this account.

**14. Variation/Deviation in quantities**

The contractor shall not make any alteration in addition to or omission from the work as described in the tender document except in pursuance of the written instructions of the Engineer-in-charge. No such deviation from the work described in the tender documents shall be valid unless the same has been specifically confirmed and accepted by the accepting officer in writing and incorporated in the contract.

The rates quoted are firm for deviation subject to minimum of (-) 20% and maximum (+) 20% of the total value of work awarded. Deviation beyond the above limits is subject to the standard terms and conditions of BHEL.

**15. Materials**

(a) Supply by Employer:

Unless otherwise specified, BHEL will not supply any materials.

**16. SUPPLY OF CEMENT AND STEEL IS TO BE MADE BY CONTRACTOR****17. SUPPLY BY CONTRACTOR**

- (i) The work is for a completed job including labour and supply of all materials except those otherwise specified in the bid document.
- (ii) All materials supplied by the contractor according to the contract conditions shall be subject to inspection and passing by the Engineer or his representatives from time to time, the contractor providing all facilities for such instruction free of cost. BHEL officers connected with the contract shall have the power at any time to inspect and examine any stores or materials intended to be used in or on the work, whether on the site or at any factory or workshop or other place where such stores or materials are being fabricated or manufactured or at any place the same are lying and the contractor shall give necessary facilities for such inspection and examination.
- (iii) The Engineer-in-charge shall be entitled to have tests made of any stores or materials supplied by the contractor shall provide at his own expense all facilities which the Engineer-in-charge may require for this purpose. If at the discretion of the Engineer-in-charge an independent expert is employed to make any such tests his charges shall be borne by the contractor only if the tests disclosed that the said stores or materials are not in accordance with the provision of the contract.
- (iv) Should the Senior Engineer/Civil Engineer/Civil consider as any time during the construction or reconstruction on prior to the expiry of the Maintenance Period that the stores or materials provided by the contractor are unsound or of quality inferior to that contracted for, or otherwise not in accordance with the contract (in respect where the decision of the Senior Engineer/Civil shall be final and conclusive) the contractor shall on demand, in writing from the Sr.Engineer-civil specifying the stores an demand or materials complained of, not with-standing that the same may have been inadvertently passed, certified that and paid forth with remove the stores or materials so specified and provide other and suitable stores or materials at his own expense, to the entire satisfaction of the Sr.Engineer/Civil Engineer/Civil and in the event of his failing to do so within a period to be specified by the Senior Engineer/C,E/C, in his demand aforesaid, the Sr.Engineer/Civil Engineer/Civil may replace within the other stores or materials complained of at the risk and expense in all respect of the contractor. The liability of the contractor under this conditions, shall not extended beyond the maintenance period aforesaid except as regards stores or materials which the Sr.Engineer/Civil Engineer/Civil shall have previously given notice to the contractor to replace (Maintenance, period for any work under this organization will be six months from the date of actual completion of the particular work and handing over to BHEL).

**18. INTERRUPTION TO THE WORKS: -**

In quoting the rates/prices the Contractor should take in to account the fact that due to the design or other stipulations at site, or the necessity to follow a particular sequence of overall construction operation, or non-supply of particular drawings, or the connected work or other reasons, interruptions are likely to be encountered in a work of this nature and magnitude. No claims for such interruptions will be entertained on any account.

**EXTENSION OF TIME OR PENALTY/LIQUIDATED DAMAGES**

Extension of time or penalty/liquidated damages as the case may be will be determined as stipulated in clause 7, 9 and 41 of BHEL General Conditions of Contract.

**19. COMPLETION OF WORK AND MEASUREMENT**

- a. All work shall be carried out according to authorized dimensions and measurement will be restricted to those authorized dimension even though the Contractor may for convenience of this work exceed the authorized dimensions.
- b. All work shall be measured in accordance with the applicable standard method of measurements prescribed by the Indian Standard Institution (1200 latest edition) unless otherwise specified.
- c. The Contractor shall admit for technical inspection, works which are likely to be embedded or covered by other works and have the necessary measurement books and certificates to this effect duly signed by the Engineer before the works are covered.
- d. On completion of the work, the Contractor must submit to the Engineer the following documents for passing of works.
  - (i) A copy of the working drawing showing thereon all addition and alterations in the process of execution.
  - (ii) A certificate for embedded and covered up works as in sub-Para (C) above
- e. The authorized Contractors representative and a representative of the Employer shall jointly sign a certificate of handing over any completed work and date of signature of that certificate will be that the date from which the maintenance period of that unit will reckoned.
- f. Notwithstanding the above insurance cover has to be taken by the contractor for the full value of work as also for the duration of the contract period. 50% of the Security Deposit shall be released only on the total completion of the building and handed over to BHEL to their satisfaction. Remaining 50% of Security Deposit shall be released subject to the stipulation in our GCC after 6 months from the date of completion of the building.

**20. MAINTENANCE OF WORK**

The contractor will be responsible for the maintenance of works during the period of construction until the various items are taken over, and for a further period of six months, from the date of taking over.

If the contractor fails to maintain the building satisfactorily, it will be got done by other agency and cost towards such maintenance together with departmental charges will be recovered from the bills/dues of the contractor.

**21. SECURITY DEPOSIT**

Upon acceptance of the tender, the successful tenderer shall remit the security deposit with Bharat Heavy Electricals Ltd., within the time specified in the letter of intent.

The rate of Security Deposit will be as below:

Up to Rs.10 lakhs	10%
Above Rs. 10 lakhs up to Rs.50 lakhs	Rs.1 lakhs + 7.5% of the amount exceeding Rs. 10 lakhs
Above Rs.50 lakhs	Rs. 4 lakhs + 5% of the amount exceeding Rs. 50 lakhs

Successful tenderer to remit Security Deposit

The contractor should submit the Security Deposit before the start of the work.

- i. Cash (as permissible under the income Tax Act).
- ii. Pay order, demand draft in favour of BHEL.

CONTRACTOR  
(With Seal)

Spec. No: DOC/TR/404/12/01/06

EMPLOYER

- iii. Local cheques of scheduled banks, subject to realization.
- iv. Securities available from Post Offices such as National Saving Certificates, KisanVikasPatras etc.,  
(Certificate should be held in the name of contractor furnishing the security and duly pledged in favour of BHEL and discharged on the back)
- v. Bank Guarantee from scheduled Banks/Public financial Institutions as defined in the companies Act subject to a maximum of 50% of the total security deposit value. The balance 50% has to be remitted either by cash or in the other form of security. The Bank Guarantee format should have the approval of BHEL.
- vi. Fixed Deposit Receipt issued by scheduled Banks/Public Financial Institutions as defined in the Companies Act. The FDR should be in the name of the contractor, A/C BHEL, duly discharged on the back.
- vii. Security Deposit can also be recovered at the rate of 10% from the running bills. However in such cases at least 50% of the Security Deposit should be collected before start of the work and balance 50% may be recovered from the running bills.
- viii. EMD of the successful tenderer shall be converted and adjusted against the Security Deposit.
- ix. The Security Deposit shall not carry any interest.

NOTE: Accepting of Security Deposit against Sl.No. (iv) and (vi) above will be subject to hypothecation or endorsement on the documents in favour on BHEL. However, BHEL will not be liable or responsible in any manner for the collection of interest or renewal of the documents or in any other matter connected therewith.

For extra items of work and deviated quantities, security deposit will be recovered at 10% of the value of deviated amount. The security deposit will be released as stipulated under clause 16(IV) of GCC.

## **22. RUNNING ACCOUNT PAYMENTS**

During execution of work, monthly payments of all works in place will be made on the basic measurements recorded in measurement sheet/book in respect of items executed but no claim on the account will be entertained, if for any reason payments are not so made.

## **23. ADVANCE**

75% of the value of imperishable materials brought to site for incorporation in the work subject to production of supporting vouchers, indicating the value of materials and hypothecation of the company. The advance shall be paid subject to the materials so brought to site are adequately stored and/or protected against damage by weather or other causes but which not at the time of payment of advance incorporated in the work. Payment of such advance however, shall be recovered from the bills pro-rata according to the quantity billed for. No other advance will be paid. No such materials shall be removed from the work site by the contractor without the written permission of the Engineer-in-charge.

## **24. STATUTORY DEDUCTION TOWARD INCOME TAX WILL BE MADE as per rules.**

25. In respect of all labour directly or indirectly employed on the work by the Contractor, the Contractor shall comply with the provisions of the contract labour (Regulation and Abolition) Act 1970 or any amendment thereof and all legislations and rules of the State and or Central Government or other Authority, framed from time to time governing the protection of health,

sanitary arrangements, wages, welfare and safety for labour employed on building and construction works. The rules and other statutory obligations with regard to fair wages, welfare and safety measures, maintenance of the register etc., will be deemed to be part of the contract.

26. The Contractor is required to take insurance for all workers employed on works towards payment for workmen compensation. The insurance has to be taken out within 15 days of the award of work and has to be produced at the time of signing agreement. Half (1/2%) shall be deducted for every bill if the contractor fails to produce a proof of having taken such an insurance to cover his workmen.  
However the contractor shall be fully responsible for all the consequences arising out of such default. This may also be read with clause 20 of BHEL GCC.

**27. TIME OF COMPLETION**

The date of commencement of work shall be counted from the date of handing over the site to the contractor. The contractor shall plan the work in such a manner that all roofs are laid before the start of the rainy season and the work is not hampered due to rain. It may be clearly understood that time is the essence of the contract and the entire work should be completed within the time imposed in the tender document letter of intent.

28. The Contractor has to pay the Works Contract Tax (Under Sec.19A of the KST Act 1957) of their own, on Monthly basis.
29. The management of BHEL shall be at liberty to terminate the contract by issuing a month's notice to the contractor without assigning any reason what so ever. As regards unsatisfactory performance or noncompliance with any of the terms & conditions of the contract by the contractor. The management of BHEL shall have the right to terminate the contractor forthwith without notice & rearrange the balance work through other agencies at the risk & cost of the contractor & under such circumstances, the Earnest Money Deposit/Security Deposit paid by the contractor shall stand forfeited.

### LIST OF INDIAN STANDARD

Following is the list of various Indian Standards, Relevant to the Civil Engg., work

#### **EARTH WORK**

IS 1200-1974, Method Part I Earthwork, Measurement of Building, and Civil Engineering works, and chapter No.2 of CPWD/specification 1977.

#### **MORTAR (PLASTERING)**

IS 2394-1965. Code of practice for application of lime plasters finish.

IS 1661-1972. Code of practice for application of cement lime plasters finish.

IS 2402-1963. Code of practice for external rendered finishes.

#### **CONCRETE WORK& RCC WORK**

IS 456-1964. Code of practice for plain and reinforced concrete.

IS 432(part 1) –1966. Mild steel and medium tensile steel bars.

IS a 1766-1866-Cold twisted steel bar for concrete reinforcement.

#### **BRICK WORK**

IS 2212-1962-Code of practice for brickwork.

#### **STONE WORK**

IS 1597-code of practice for construction of stone masonry.

#### **MARBLE WORK**

IS 1124-1974 Methods of test for water absorption of natural building works.

#### **STEEL WORK**

IS 800-1962-Code of practice for use of structural steel in general building construction.

IS 1308-1975-Steels doors, windows and ventilators

IS 1081-1960-Code of practice for fixing glazing of metal (steel & Aluminium doors, windows & ventilators)

ARE 1161-1968-Steel tubes for structural purposes.

IS 4351-1967-Steel doorframes.

IS-6245-5245-1971-Metal rolling shutters and rolling grills.

#### **FLOORING**

IS 2114-1962-Code of practice for laying in situ terrazzo floor finish.

IS 2571-1971-Code of practice for in situ cement concrete flooring.

IS 5313-1969-code of practice of lying of flexible P.V.C. sheet & tiles flooring.

#### **ROOFING**

IS 3007(pt.-I)-1964-code of practice of lying of corrugated cement sheets.

#### **FINISHING**

IS 133-1975-Enamel, Interior (a) under coating (b) Finishing colour as required.

IS 348-1966-French Polish.

IS 427-1965-Distemper, dry colour as required.  
 IS 425-1969-Distemper, oil emulsion as required.  
 IS 5410-1969-Cement paint, Colour as required.  
 IS 5011 (pt.1)-1969-Plastic emulsion paint for interior use.  
 IS 6278-1971 code of practice for white washing & colour washing.

#### **DEMOLISION AND DISMANTILING.**

IS 1200 (pt. XVIII)-1974-Method of measurements of demolition and dismantling.

#### **SAFETY CODE**

IS 5915-1970-Safety code for construction including use of hot bituminous materials.  
 IS 4130-1970-Safety code for demolition of building.  
 IS 3754-1966-Safety code for excavation works.  
 IS 3606(Pt.-I)-1966-Safety code for Scaffolds.

#### **APPROVED BRAND OF PAINTS TO BE USED**

##### DISTEMPER

BRAND:- ASIAN, BERGER, BRITISH PAINTS, JENSON & NICHOLSON, NEROLAC or Equivalent.

##### SYNTHETIC ENAMEL PAINT

ASIAN (APCOLITE SHILIMAR, BRITISH, JENSON & NICHOLSON, NEROLAC, BERGER or Equivalent

##### PLASTIC EMULSION

BRITISH, NEROLAC, JENSON & NICHOLSON, BERGER or Equivalent.

##### WATER PROOF CEMENT PAINT

SUPER SNOWCEM or equivalent.

##### DISTEMPERING ON NEW SURFACE. (OILBOUND)

1. COAT OF PRIMER ..... 0.081 Ltrs/Sqm (one coat)
2. COAT OF DISTEMPER ..... 0.15 kg/Sqm (2 coats)

##### DISTEMPERING WITHOUT PRIMER

FOR 1 COAT	.....	0.10 Kg/Sqm (For 1 coat)
FOR 2 COATS	.....	0.20 Kg/Sqm (For 2 coats)

##### SYNTHETIC ENAMEL PAINT.

- a) ON NEW SURFACE ... PRIMER .... 0.09 Litre/Sqm (For 1 coat)  
     ENAMEL PAINT (2 COATS) .... 0.15 Litre/Sqm (For 2 coats)
- b) ON SURFACE  
     2 COATS WITHOUT PRIMER ... 0.20 Litre/Sqm  
     1 COAT ..... 0.10 Litre/Sqm

## c) WATER PROOF CEMENT PAINT

1 COAT ... 0.18 Kg/Sqm

2 COAT ... 0.30 Kg/Sqm

## d) PLASTING EMULSION PAINT:

2 COATS OF PLASTIC EMULSION .... 0.121 Litre/Sqm

1 COAT OF PLASTIC EMULSION .... 0.073 Litre/Sqm

ON NEW SURFACE

1 COAT PLASTIC FIX PRIMER ... 0.081 Litre/Sqm

2 COATS PLASTIC EMULSION ... 0.121Litre/Sqm

<b>LIST OF MATERIALS OF APPROVED BRAND OF MANUFACTURERS</b>		
1	Cast Iron Pipes	a) Indo-Swedish Pipe Mfg. Co.ltd.,] b) Bengal Iron Foundry c) Hindustan Engineering Products or Equivalent.
2	G.I.Pipes	TATA, Zenith, Surya prakash or Equivalent
3	G.I.FITTINGS	R Brand, TATA or Equivalent
4	C.P.FITTINGS	Ark ESS ESS, Plumber Driploss or Equivalent
5	Gun Metal Valves	Leader Neta or Equivalent
6	W.C.pans, wash basins Toilet paper holder, Soap trays, Urinals,Auto Flushing tanks.	Hindustan, Parry were CeraNeycer or equivalent
7	W.C.Seats	Commander Bestolite or Equivalent
8	Flushing Cisterns	Hindustan, Sea shell or Equivalent
9	Mirrors	Atul Glass Works, warrior or equivalent
10	Stoneware Pipes	DalmiaMysore Stoneware Pipe & Co., Andhra Pradesh Stoneware Pipe company
11	Door Shutters Commercial ply teak Veneered flush shutters With ISI make.	Kutty Flush Doors and furnishes Co., Mysore Plywood or equivalent Nikky Assam or Equivalent
12	Door framed cold rolled framed sheet sections conformed sheet to IS 4351- 1976.	NSL section T.I. Section or equivalent.

13	Commercial fly/teak Veneered ply block board	Anchor, Mafatlal, Arch, National or equivalent
14	Steel windows with	1) M/s Madhy Industries shutter frame. 2) M/s Eswari Enterprises, Rajajinagar 3) M/s Chamundi Fabricators & Engg., 4) M/s Prabhu and Co., (ACEW)
15	.Rolling shutters	Kohinoor, Hericles or equivalent.
16	Bottle traps	Orient & ARK or equivalent.
17	PVC pipes	a) Oriplast b) Prince c) Premier d) Finolex
18	Aluminium Sections	a) Indal b) Zindal or Equivalent
19	Cement	a) Zuary b) ACC c) Cormandala d) L&T e) Birla or equivalent
<p><b><i>N.B All equivalent materials shall have to be approved from the Engineering-in charge before being used.</i></b></p>		

**FORM OF TENDER**

Having examined the invitation to bid, Instructions to Bidder, General conditions of contract, special conditions, specifications tender schedule, contract drawings and other documents for the above work, we the undersigned, offer to construct, erect complete and maintain the whole of the said in conformity with the said bid documents on the terms and conditions and under the provisions set out or called for in the contract documents at the rates listed in the schedule of unit prices or else wherein the contract documents.

We undertake if our bid is accepted, to commence the works within 7 days from the date of issue of award and to complete and delivery the whole of the works comprised in the contract as per the time schedule agreed to the contract document.

We agree to abide by this bid for the period of three months from the date fixed for receiving the same and it shall remain binding upon us and may be accepted at any time before expiry of the period.

Until and unless a formal agreement is prepared and executed this bid, together with your award thereof shall constitute a binding contract between us.

CLAUSE 58 OF GENERAL CONDITIONS OF CONTRACT

ARBITRATION:

Except where otherwise provided for in the contract all questions and disputes relating to the meaning of the specifications, designs, drawings and instructions herein before mentioned as to the quality of workmanship or materials used on the work or as to any other question, claim, right, matter or thing whatsoever in any way arising out of or relating to the contract, designs, drawings, specifications, estimates, instructions, orders or these conditions or otherwise concerning the works, or the execution or failure to execute the same whether arising during the progress of the work or after the completion or abandonment thereof shall be referred to the sole arbitration of the Executive Director/General Manager of BHEL and if the Executive Director/General Manager is unable or unwilling to act to the sole Arbitration of some other person appointed by the Executive Director / General manager willing to act as such Arbitrator. There will be no objection if the arbitrator so appointed is an employer of BHEL or an employer of any other unit of BHEL and that he had to deal with the matters to which the contract relates and that in the course of its duties as such he had expressed views on all or any of the matters in dispute or difference. The Arbitrator to whom the matter is originally referred being transferred or vacating his office or being unable to act for any reason, such Executive Director / General Manager as aforesaid at the time of such transfer vacation of office or inability to act, shall appoint another person to act as arbitrator in accordance with the terms of the contract. Such person shall be entitled to proceed with the reference from the stage at which it was left by his predecessor. It is also a term of this contract that no person other than a person appointed by such Executive Director/General Manager or an employee appointed as arbitrator as aforesaid should act as arbitrator and the arbitrator shall give reasons for the award.

Subject as aforesaid the provision of the Arbitration Act, 1940 or any statutory modification or re-enactment thereof and the rules made there under and for the time being in force shall apply to the arbitration proceeding under this clause.

It is a term of a contract that the party invoking arbitration shall specify the dispute or disputes to be referred to arbitration under this clause together with the amount or amounts claimed in respect of each such dispute.

The arbitrator(s) may from time to time with consent of the parties extend the time, for making the publishing the award.

The work under the contract shall, if reasonably possible, continue during the arbitration proceeding and no payment due or payable to the contractor shall be withheld on account of such proceedings.

The arbitrator shall be deemed to have entered on the reference on the date he issued notice to both the parties fixing the date of the hearing.

The arbitrator shall give a separate speaking award in respect of each dispute or difference referred to him

The venue of arbitration shall be such place as may be fixed by the arbitrator in his sole discretion.

The award of the arbitrator shall be final, conclusive and binding on all parties to this contract.

# **TECHNICAL SPECIFICATION**

## Functional requirement specification

### 1. Introduction:

This specification covers the requirements for setting up a modern Training Hall for conducting training programs on Equipment supplied by BHEL. The Training Hall is provided with modern audio-visual equipment, modular tables with provisions for workstations and monitors, large video screens, convenient lighting arrangement, appropriate interior décor, false flooring, and other amenities.

The scope of this specification includes interior design and supply of all materials, execution and setting up of training room by providing acoustic lining for the walls, false ceiling, and stepped platform, Supply of all materials, execution and setting up of the above facilities is to be done at BHEL works.

### 2. Location

**1.1** The proposed work is to be carried out in the Training hall situated at 4th Floor, New Engineering Building, at EDN. Plan of the proposed area is attached as Annexure-1.

**3. Architecture:** The Training Hall is envisaged to be a modern, state-of-the-art facility for conducting interactive, audio-visual sessions for about 32 participants, and the ergonomics must support this objective. The arrangement of seating of the participants, faculty and support staff, provisions for deliverance of lectures and presentations, both audio and visual, provisions for hands-on working on workstations and monitors, interior décor, flooring, lounge area, and such other amenities as may be required to support the concept, should be integral to the conception of the architecture. A suggestive arrangement of the hall for the proposed scope of work is given in Annexure-2. Bidders are free to offer any other architectural arrangement that may satisfy the requirements of this specification subject to acceptance and approval by BHEL.

The main Training Hall: Dim. approx. 10.3x10.25 m. This hall is bounded by a concrete wall on the west, concrete wall with openings for shuttered windows on the north, and partitions of MDF boards and glass panes in Aluminium frames on the east and south sides. Floor to ceiling height for all areas is 3.5 m. Refer attached Annexure 1 and Annexure 2 for dimensional details.

**4. Scope of Supply** (For details, refer Bill of material in Part II – Price bid)

**4.1.** Providing and fixing of stepped wooden platform consist of wooden platform with 4 steps of minimum 4” height of each site.

**4.2. ACCOUSTIC WALL PANELLING**

Supply and installation of grooved acoustic panels of high density fiber/particle board with approved laminated finish on front and balancing layer adhered to its rear face.

**4.3 FALSE CEILING**

Providing and fixing suspended false ceiling system which includes all fasteners and fixtures to hold it.

**4.4. SERVICES**

CONTRACTOR  
(With Seal)

Spec. No: DOC/TR/404/12/01/06

EMPLOYER

All Labor works, installation of above points 5.1-5.4, and removing the existing Aluminium door and re-fixing with alteration, and any similar work if any.

## 5. DOCUMENTATION

5.1 Vendors to submit, the following along with the bid:

- (a) Clause wise comments. If any deviations are requested, supplier to clearly and bring out the details of deviations.
- (b) Complete Bill of Materials along with detailed specifications,
- (c) List of similar jobs undertaken/completed for different clients
- (d) A schedule of activities with estimated timeframe.
- (e) Detailed 3D view of proposed arrangement or detailed drawings may be submitted along with the proposal.

5.2 On award of the contract, the vendor is required to submit

- (a) Fully developed 3-D views in colour from different angles to match the GA drawing for approval
- (b) Complete Bill of Materials along with detailed specifications, colour scheme etc., make and estimated quantities,
- (c) Samples of Major items to be submitted for approval. This sample will be kept with BHEL for reference.
- (d) Catalogues, manuals, service instructions of all supplied equipment

## 6.0 WARRANTY

One year from date of completion or 18 months from date of supply against manufacturing defects and defective workmanship.

Note: A separate work order is issued for carrying out electrical and networking related work. The successful bidder of this tender shall also co-ordinate, with electrical contractor and BHEL Engineer in-charge and ensure that the awarded work is carried out seamlessly.

Vendor to discuss in detail regarding the cutouts or any other work required to be carried in the ceiling/wall paneling / platform for Electrical contractor. These works shall be planned in advance with mutual co-ordination.



ANNEXURE-2

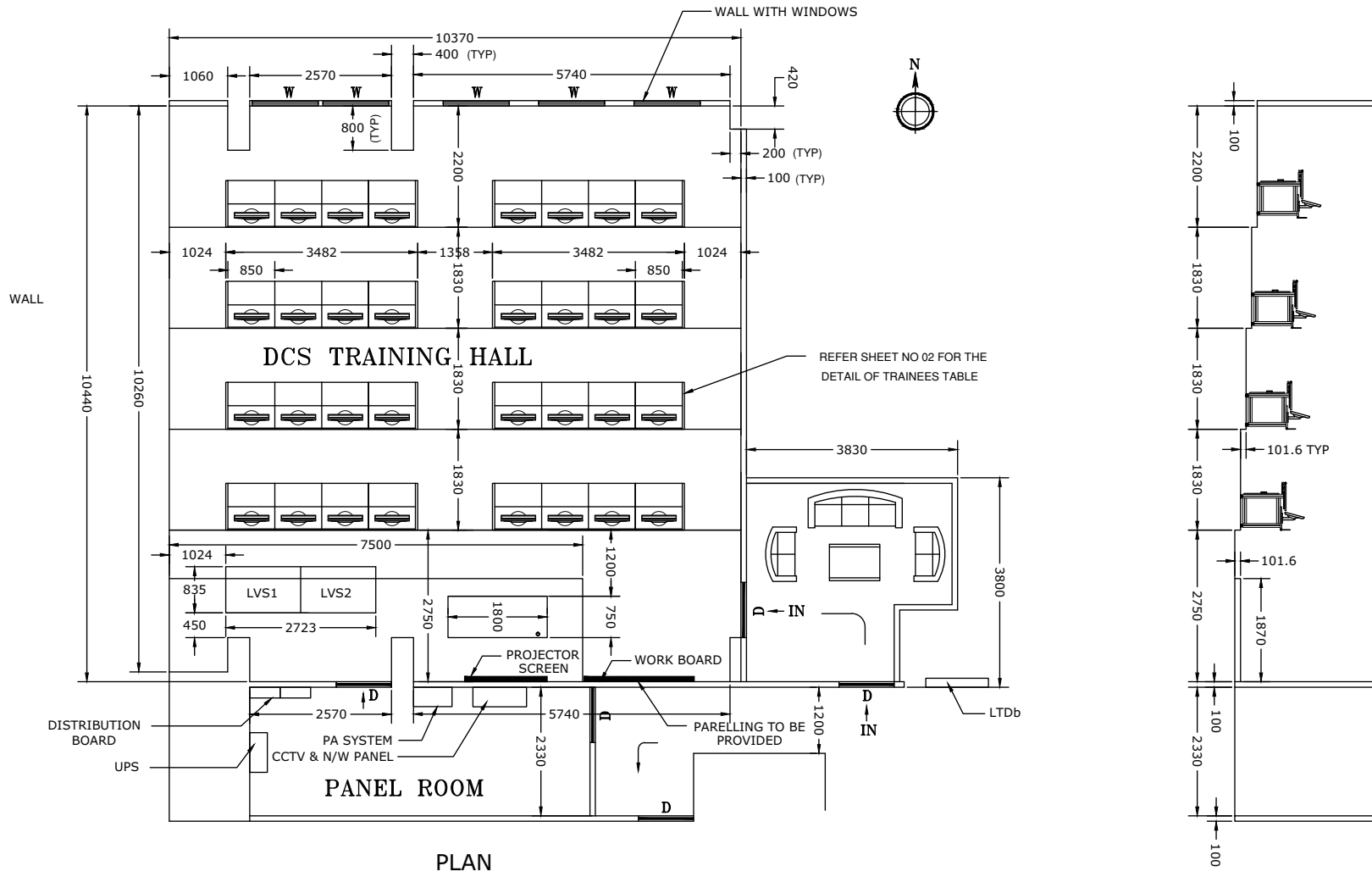

PLAN

NOTE:

HALL HEIGHT = 3 Mtr.  
 P. WALL = 100 mm  
 ALL DIMENSIONS ARE IN MM  
 SHEET NO - 01 OF 02

TITLE : SUGGESTIVE ARRANGEMENT OF THE DCS TRAINING HALL

## ANNEXURE-2

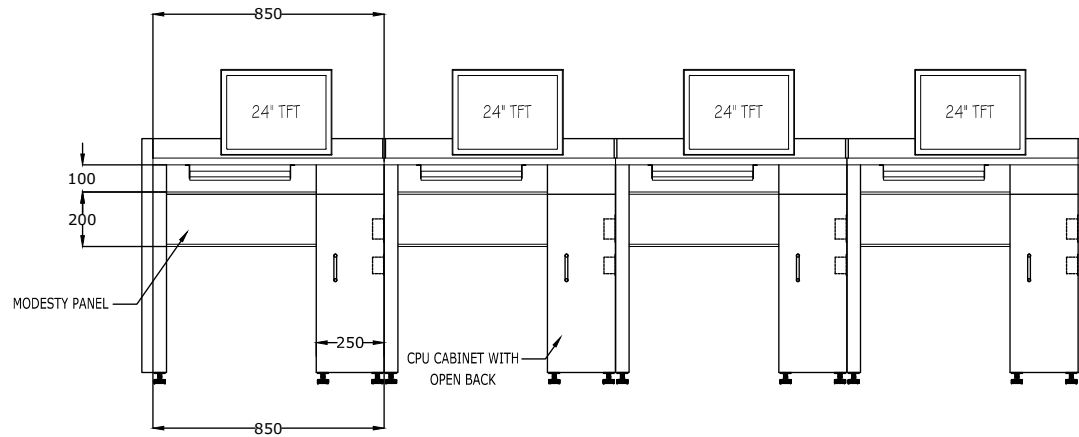

FRONT VIEW

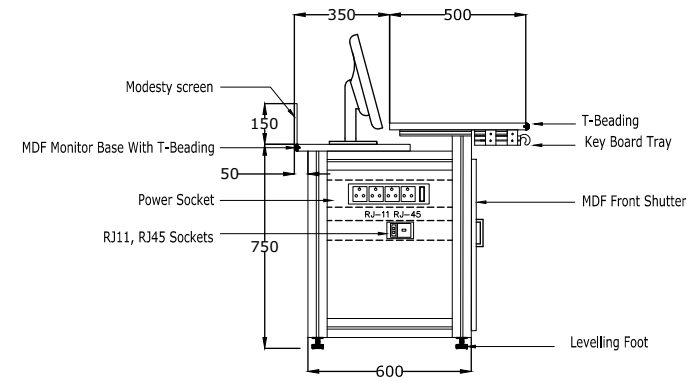

SIDE VIEW

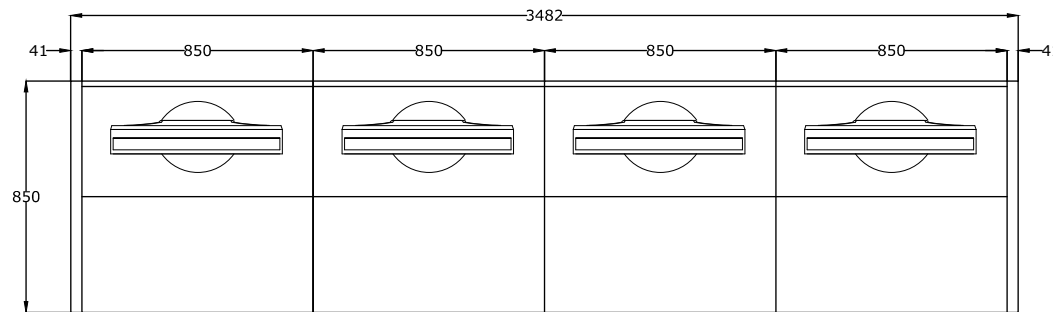

TOP VIEW

**NOTE:**

**ALL DIMENSIONS ARE IN MM  
SHEET NO - 02 OF 02**

**TITLE : OGA OF TRAINEES TABLE**

**SCHEDULE OF WORK/  
PRICE BID**

## PART II

SCHEDULE OF WORK / PRICE BID									
NAME OF THE WORK : EDN Demo cum Training Hall									
Sl. No.	Description of Work	Unit	Nos	L (m)	B (m)	H (m)	Qty.	Unit Rate	Amount
	<b>STEPPED PLATFORM:</b>								
	<b>Stepped platform consisting of 4 steps of 4" height along with a platform (4" height) for the instructor and LVS system as per Drawing Ref:</b>								
	<b>PLATFORM - Structural Support</b>								
1	Providing structural steel work in angles/ tees/ channels/ tubes/ box sections etc. riveted, bolted or welded in built up sections / MS Hollow sections, trusses and framed work, including cutting, hoisting and fixing in position and applying a priming coat of approved steel primer and two coats of synthetic enamel paint all complete at all heights and levels for stepped platform as per the direction of the Engineer-in-charge. Rate to be inclusive of material, transportation, taxes, fixtures etc complete.	Kg					1103.00		
	<b>PLATFORM-WOODEN SURFACE</b>								
2	Providing & fixing of Solidwood Flooring of ' <b>Species: Merbau</b> ' of 17-19mm thick x 120-125mm wide, pre-finished boards with builders clean finish method. The product should be treated with UV/ Lacquer coated surface treatment, Kiln dried, 'A' Grade with all round tongue and groove fitting system for simple and infinite installation. With underside grooves for better stability. Planks should be dried to a wood moisture level of 8% +/- 2%. (Relevant Test Certificates to be provided) Solidwood flooring is installed in accordance with BS 8201:1987 in builders clean finish with the leveled base floor which has no undulations, completely dry and dust free. The product should be installed with matching skirting and profile and should be suitable for commercial applications / high traffic areas. Rate to be inclusive of material, transportation, taxes, fixtures etc complete.	Sqm					117		

## PART II

Sl. No.	Description of Work	Unit	Nos	L (m)	B (m)	H (m)	Qty.	Unit Rate	Amount
	<b>FALSE CEILING</b>								
	<b>FALSE CEILING -</b>								
3	Providing and fixing <b>suspended ceiling system</b> of Armstrong / Environtech with manufacturer's recommended structurals, which includes providing and fixing of the hot dipped galvanized polyester paint baked wall molding of size 0.457mm thick having equal flange of 22mm along the perimeter of ceiling screw fixed to brick/wall/partition with the help of nylon selves and screws. Then suspending main runner of size of 0.33mm thick having a flange of 24mm and web of 38mm at every center using suitable suspension from the soffit. Then clipping rotary duple attached 1200mm cross tee of size 0.254mm thick having a flange of 24mm and web 30mm onto the main runner at every 600mm cross tees of every 600mm center to form a grid of 600X600mm. Finally laying mineral fiber acoustical ceiling tiles of PRIME FINE FISSURED TEGULAR EDGE of size 595X595X12mm onto the formed grid. Rate to be inclusive of material, transpotation, taxes, fixtures etc complete.	Sqm					111		
4	<b>Ply board back:</b>								
	Providing and fixing 12mm thick ply wood marinerproof board for Stepped platform, Risers of platform and Walls. Rate to be inclusive of material, transpotation, taxes, fixtures etc complete. (Total area to be covered: Platform = 10.5 x 10.5m + Platorm risers = 10.5m x 0.12m x 4 + Wall = 10.5m x 3m x 4 walls = 242sqm)	Sqm					243		

## PART II

Sl. No.	Description of Work	Unit	Nos	L (m)	B (m)	H (m)	Qty.	Unit Rate	Amount
5	<b>Wall Panelling</b> :Acoustical wall paneling : Providing,supplying and installing wall panelling of Armstrong / Environtechmake Wood works perforated boards panels of size 600mm wide & 12mm thick & 800 mm length made of high density particle board with an approved lamination facing and an melamine balancing layer on the reverse side. The boards shall have a special perforation pattern where the visible surface has the Helmholtz round perforation dia of 3mm and reverse side with 12mm with 16mm pitch / oval perforation perforation pattern of 32mm wide. The edges of the panel shall be grooved to recived splines for installation. The back of the panel shall have sound absorbing non woven acoustical fleece. The panel are mounted on to the special aluminium splines provided by the manufacturer. All as per design & drawing. Rate to be inclusive of material, transpotation, taxes,fixtures etc complete.	Sqm					147		
6	Dismantling aluminium / gypsum/ wooden partitions, doors, windows, fixed glazing and false ceiling including disposal of unserviceable surplus material and stacking of serviceable material within 50metres lead etc. complete at all heights and levels as per the direction of the Engineer-in-charge. Rate to be inclusive of material, transpotation, taxes,fixtures etc complete.	Sqm					2.88		
7	Fabricating and fixing available Aluminium partition/ Doors/ Windows etc. (Rate is inclusive of Aluminium clip, beading, screws etc.) complete with available aluminum section, particle board and glass.	Sqm					2.88		
8	Providing and fixing 9" wide & 18mm thick beach wood planks to window / door jambs including polishing. Rate to be inclusive of material, transpotation, taxes,fixtures etc complete.	Sqm					9.00		
<b>Total Estimated Value (inclusive of Taxes)</b>									