

ALL DIMENSIONS ARE IN MILLIMETRES

REV	DATE	ALTERED
		APPROVED

CAUTION: The information on this document is the property of BHARAT HEAVY ELECTRICALS LTD. It must not be used directly or indirectly in any way detrimental to the interest of the company.

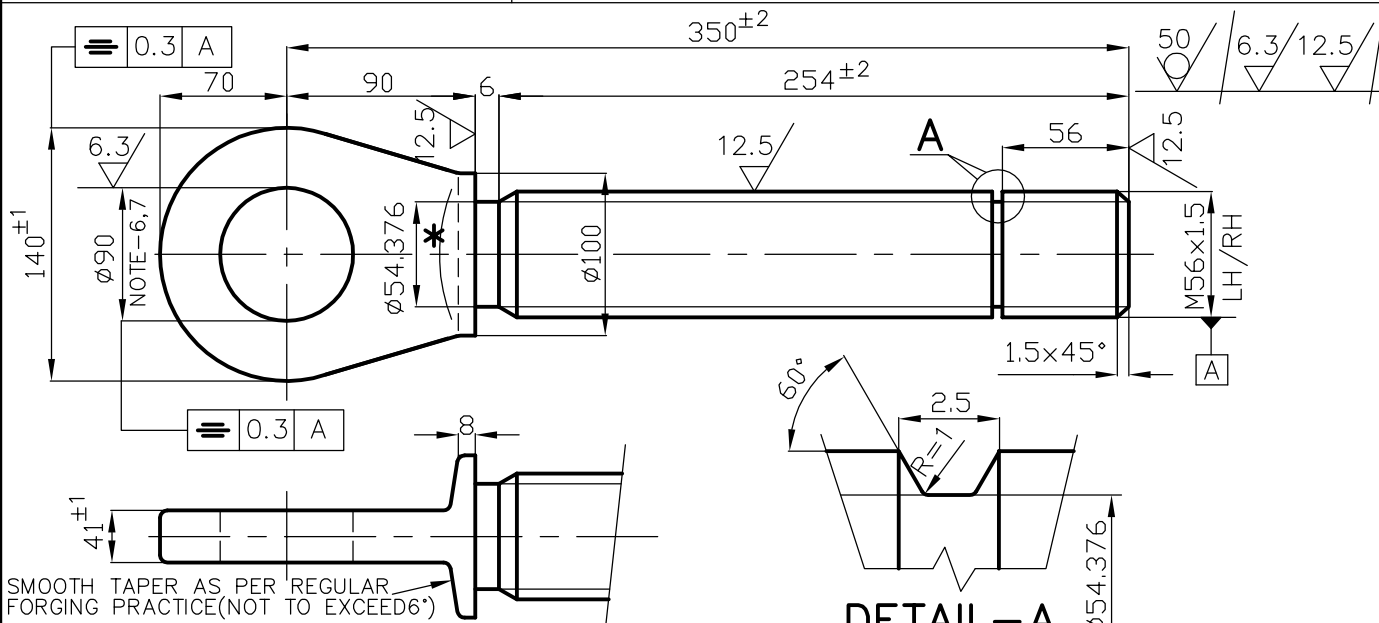

NOTES:

- 01) MATERIAL FOR ITEM.01/03- SA105 / IS1875CL3-30C8 / IS8500FE540; ITEM 01 HAS TO BE FORGED.
- 02) ITEM 01&03 ARE TO BE ELECTROGALVANISED & YELLOW CHROMOTISED TO A DEPTH OF 15 MICRONS.
- 03) THREADS SHALL CONFIRM TO IS4218.
- 04) UNSPECIFIED RADIUS FOR ITEM 01 SHALL BE AS PER REGULAR FORGING PRACTICE.
- 05) DETAILS OF NUT -ITEM 03 (LH/RH): THREAD SIZE M56x1.5; HEIGHT 45; DIM ACROSS FLATS 85+0-1; DIM ACROSS CORNERS 98mm.
- 06) ITEM 02 MAINTENANCE FREE RADIAL SPHERICAL BEARING WITH SLIDING CONTACT SURFACE. OUTER RING OF CARBON CHROMIUM STEEL IS HARDENED, GROUND, DELIBERATELY FRACTURED AT ONE SINGLE POINT, WITH INTERNAL SLIDING LAYER OF PTFE FABRIC. CARBON CHROMIUM STEEL INNER RING IS HARDENED, GROUND AND THE SLIDING CONTACT SURFACE IS HARD CHROMIUM PLATED & POLISHED. RUBBING DOUBLE-LIP SEAL AT BOTH SIDES.
- 07) ITEM 02 HAS TO BE SUITABLY FIT INTO ITEM 01 AS PER SKF OR EQUIVALENT'S BEARING PRACTICE WITH SUITABLE TOLERANCES ON MATING SURFACES OF ITEM 01,02.
- 08) MARK ON ITEM 01 AT LOCATION * 2 ALPHA LETTERS REPRESENTING SUPPLIER'S CODE; 250KN; (LH FOR LH ONLY) MARK LH ON 03 FOR LH NUT.
- 09) TO BE SUPPLIED IN ASSEMBLED CONDITION WITH SUITABLE PACKING.
- 10) STOCK CODE FOR RH ASSY-94 821 578 0000; FOR LH ASSY 94 821 588 0000.

ITEM No.	DESCRIPTION	QTY	WEIGHT kg	REMARKS
01	FORGED ROD END (WITHOUT BEARING)	1	9.700	
02	MAINTENANCE FREE SPHERICAL BEARING STEEL/PTFE FABRIC-NOTE6,7	1	1.100	SKF GE60TE2RS OR EQUIVALENT
03	HEX. NUT M56x1.5 LH/RH	1	1.360	

STANDARD

	BHARAT HEAVY ELECTRICALS LIMITED PIPING CENTRE CHENNAI 600 017		DRN	R.ANANTH	SIGN	DATE	06.10.08	NO. OF VAR
	CHD	R.ANANTH		06.10.08				
	APPD	M.N.VASUDEVAN		06.10.08				
DEPT CODE	GRADE OF UNTOL.DIM C / M / F	SCALE N.T.S	WEIGHT (KG.) 12.160	REF. TO ASSY./OLD DRG. 3-80-999-97163		ITEM NO.		NO. OF ITEMS
TITLE ROD END WITH NUT -250KN			CARD CODE U 01	DRAWING NO. 4-80-999-93167			REV 00	