

DRG. NO. 3-61-989-04520

12.5

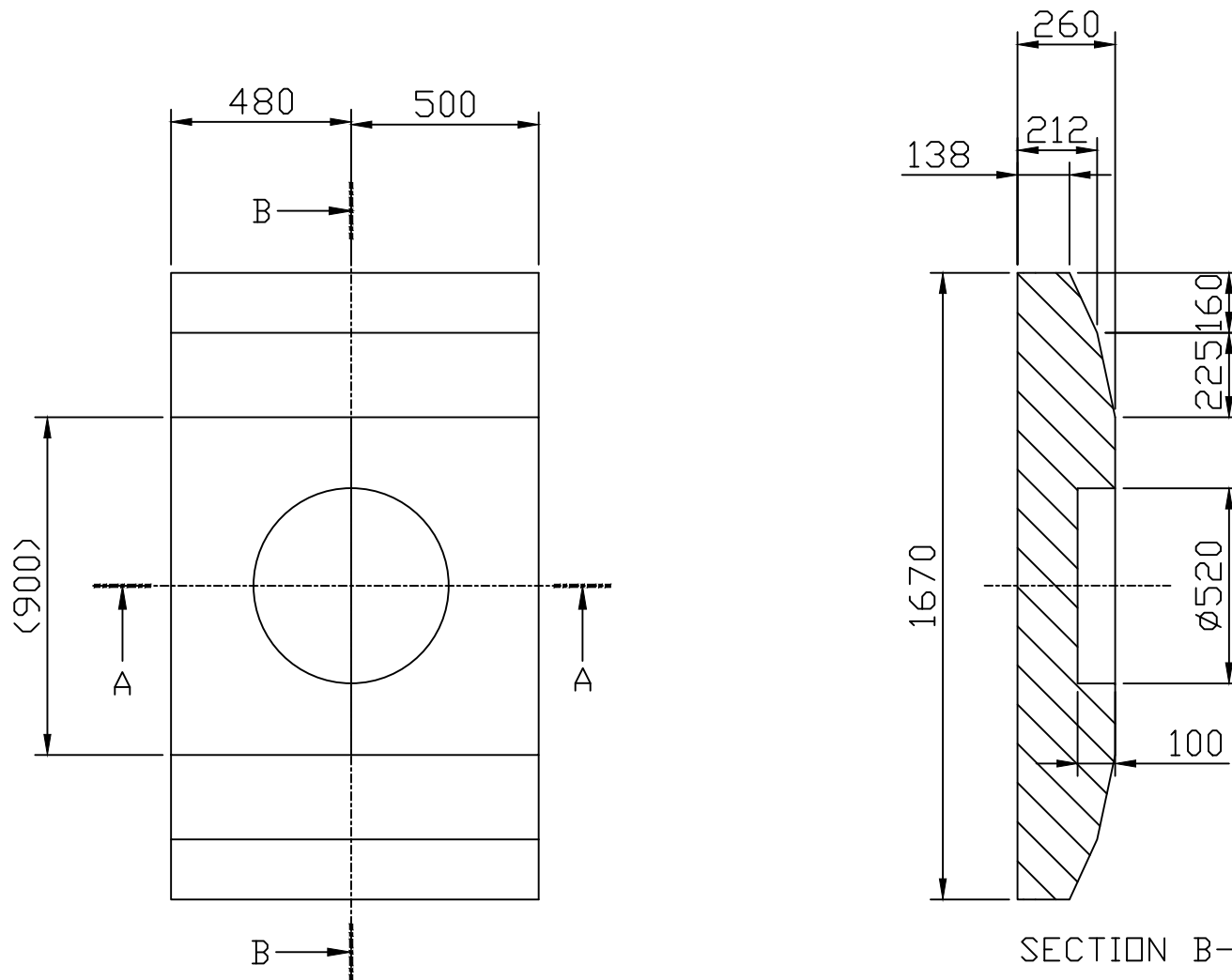

SECTION B-B

TECHNICAL REQUIREMENTS:

- DRG. SHOWS THE CASTING IN ROUGH MACHINED CONDITION.
- SURFACE FINISH OF THE ROUGH MACHINED CASTING TO BE 12.5 MICRONS.
- FOLLOWING NDT TO BE DONE ON ROUGH M/CED CASTING.
100% UT AS PER LEVEL-II OF AA0850104
100% MPI AS PER LEVEL-II OF AA0850134

1	CASTING							
ITEM NO.	DESCRIPTION	DRAWING NO.	VAR. NO.	RAW MATERIAL SIZE OR CASTING DRG. NO. OR FORGING DRG. NO.	MATERIAL CODE	NET WT.	GROSS WT.	
					AA19511		1	
					MATERIAL SPECN.	QUANTITY		

THE FOLLOWING CONDITIONS APPLY EXCEPT OTHERWISE STATED.

- REF. TO HY0230261 FOR UNSPECIFIED TOLERANCES.
- CHAMFER M/CD. SHARP EDGES 1.2 TO 1.0 AT 45°.
- INTERNAL M/CD. CORNER RADII 1 TO 0.7
- THE SURFACE ROUGHNESS WHERE-EVER NOT SHOWN SHALL BE TAKEN FROM THE SURFACE ROUGHNESS SHOWN OUT SIDE THE BACK SLASH GIVEN OR THE TOP MOST RIGHT CORNER OF THE DRG.

TYPE OF PRODUCT
OR
NAME OF CUSTOMER/PROJECT



BHARAT HEAVY ELECTRICALS LTD.
HYDERABAD

	NAME	SIGN.	DATE	NO. OF VAR.
DRN.	BGK		10.06.22	
CHD.	MANIVAS		10.06.22	
APPD.	MAHESH		10.06.22	

DEPT. PULV ENGG.		SCALE	WEIGHT (KG)	REF. TO ASSY DRG.	ITEM NO.	NO. OF ITEMS
CODE 446		NTS	2882	3-61-989-04521	01	01
TITLE				DRAWING NO.	REV.	
TRUNNION BLOCK (CASTING) ROUGH MACHINED				3-61-989-04520	00	
SHEET NO.			NO OF SHEETS			

THE INFORMATION ON THIS DOCUMENT IS THE PROPERTY OF BHARAT HEAVY ELECTRICALS LTD. IT MUST NOT BE USED DIRECTLY OR INDIRECTLY IN ANY WAY DETRIMENTAL TO THE INTEREST OF THE COMPANY.

FILE NAME

1 212 02 20106
REF.DRG.NO.

INVENTORY NO.

REV.	DATE	ALTERED	REV.	DATE	ALTERED
		CHD. APPD.			CHD. APPD.
ZONE			ZONE		