

TD-201 Rev No. 00 Form No.	 <b>PE&amp;SD, HYD</b>	<b>PRODUCT STANDARD</b> <b>BHARAT HEAVY ELECTRICALS LIMITED</b> <b>PROJECT ENGINEERING &amp; SYSTEMS DIVISION</b>		<b>PY-AS-4-M170-8564-11</b>
				Rev No. 00
				Page 1 of 4

**COPYRIGHT AND CONFIDENTIAL**  
 The information on this document is the property of BHARAT HEAVY ELECTRICALS LIMITED, It must not be used directly or indirectly in any way detrimental to the interest of the company.

**JOB SPECIFICATION**  
  
**FOR ON-OFF**  
  
**JACKETED ECCENTRIC / ROTARY PLUG VALVES**  
  
**WITH**  
  
**PNEUMATIC ACTUATOR**

**PROJECT : IOCL PARADIP SULPHUR RECOVERY UNIT**  
  
**CUSTOMER : M/s. INDIA OIL CORPORATION LIMITED.**

Ref. Doc	<b>SYSTEM ENGINEERING</b> <b>PROJECT ENGINEERING &amp; SYSTEMS DIVISION</b> Refer to record of revisions.	Prepared:  Anupam	Approved:  M.S.S.N.	Date:  07.06.22
----------	---	-------------------------	---------------------------	-----------------------

TD-201 Rev No. 00	 PE&SD, HYD	<b>PRODUCT STANDARD</b> <b>BHARAT HEAVY ELECTRICALS LIMITED</b> <b>PROJECT ENGINEERING &amp; SYSTEMS DIVISION</b>	<b>PY-AS-4-M170-8564-11</b> Rev No. 00 Page 2 of 4
<b>COPYRIGHT AND CONFIDENTIAL</b> The information on this document is the property of BHARAT HEAVY ELECTRICALS LIMITED . It must not be used directly or indirectly in any way detrimental to the interest of the company.	<p><b><u>GENERAL:</u></b></p> <p>This job specification document specifies the requirements of <b>Pneumatic operated on-off jacketed eccentric/rotary plug valves</b> package applicable for IOCL Paradip Sulphur Recovery Unit.</p> <p>Bidder shall read this document in conjunction with '<b>Material Requisition for on off valves</b>' (<b>Doc. No. B366-999-YC-MR-2451</b>), for the technical requirements, scope of supply &amp; services, design criteria, requirements of quality, inspection &amp; testing, documentation etc. Bidder shall also refer to all the enclosures listed at the end of this job specification.</p> <p>Bidder shall comply with all the requirements specified in the documents referred above.</p> <p><b>1. <u>SCOPE OF SUPPLY FOR THE PROJECT:</u></b></p> <p>The following equipments / items shall be supplied along with necessary accessories for each item, by the bidder as a part of Package scope of supply for the project.</p> <ul style="list-style-type: none"> <li>i. Pneumatically Operated On-off jacketed eccentric/rotary plug valve as per Datasheet Index &amp; datasheet (Doc No: B366-999-16-51-ID-2451) furnished as part of the said Material Requisition.</li> <li>ii. Mandatory Spares shall be offered as per <b>Price bid format (Annexure-1A) of the Specification.</b></li> </ul> <p>The detailed scope of supply and services shall be referred in various sections of <b>Material Requisition for on off valves</b>' (<b>Doc. No. B366-999-YC-MR-2451</b>).</p> <p><b>2. <u>CHECK LIST:</u></b></p> <p>A check list format is attached with this document.</p> <p><b>Bidder shall mandatorily submit signed copy of Checklist (strictly in Purchaser's format) with supplier's sign and Offers received without this document shall summarily be rejected.</b></p> <p><b>3. <u>INPUT DATA:</u></b></p> <p>The input datasheet for the selection of Pneumatic on-off jacketed eccentric/rotary plug valves is specified in the Datasheet Index &amp; datasheet (Doc No: B366-999-16-51-ID-2451) furnished as part of the said Material Requisition. The data in these datasheet includes the operating parameters, design parameters, etc. Bidder shall offer the valves to meet these requirements.</p> <p><b>4. <u>PROJECT SPECIFIC DATA / REQUIREMENTS:</u></b></p> <p>Bidder shall mandatorily follow Sub Vendors List for On-off valves with pneumatic actuator, as per <b>Annexure-5</b>.</p>		
Ref. Doc			

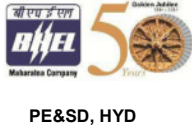

**PRODUCT STANDARD**  
**BHARAT HEAVY ELECTRICALS LIMITED**  
**PROJECT ENGINEERING & SYSTEMS DIVISION**

**COPYRIGHT AND CONFIDENTIAL**  
The information on this document is the property of BHARAT HEAVY ELECTRICALS LIMITED .  
It must not be used directly or indirectly in any way detrimental to the interest of the company.

In case of ambiguity of any technical requirement among the above referred documents, a clarification/ query shall be raised by the bidder and get clarified from Purchaser during pre-bid stage itself.

In any case, the document specifying more stringent requirement / more extended scope of supply shall be considered to be in Bidder's scope of supply.

**5. SPARES REQUIREMENT:**

**5.1 Commissioning Spares**

All applicable commissioning spares shall be included in the scope of bidder, as mentioned in the bidder's price bid format.

**5.2 Mandatory Spares :**

Mandatory Spares shall be offered as per **Price bid format (Annexure-1A) of the Specification.**

**5.3 Recommended Spares :**

Not Applicable.

**6. LIST OF ENCLOSURES / ANNEXURES :**

The following documents are enclosed with this document. Bidder shall submit the technical offer meeting the requirements furnished in all of these documents.

Sl.No.	Doc.No.	Description
1.	B366-999-YC-MR-2451	Material Requisition for on off valves
2.	Annexure 1	Price Bid Format
3.	Annexure 2	Checklist format
4.	Annexure 3	Format for Deviation
5.	Annexure 4	Format for Pre-Bid Queries
6.	Annexure 5	List of Sub-Vendor List
7.	Annexure-6	Master Document List
8.	Annexure-7	QAP Guideline & Format





**IndianOil**

## Standby SRU(525TPD) Train of IOCL Paradip Refinery

On-Off Valves

(Document No : B366-999-YC-MR-2451)



Click on the Document Title to go to that section of the document

<b>Table of Contents</b>			
<b>Document Number</b>	<b>Rev.</b>	<b>Document Title</b>	<b>Page Number</b>
B366-999-YC-MR-2451	B	On-Off Valves	3
B366-999-16-51-VDR-2451	B	VENDOR DATA REQUIREMENTS	8
B366-999-16-51-SIV-2451	B	SPECIAL INSTRUCTION TO VENDOR	11
B366-999-16-51-CF-2451	A	COMPLIANCE FORMAT	18
B366-999-16-51-SK-2451	A1	DRAWING	19
B366-999-16-51-ID-2451	B	DATASHEET INDEX	20
080557C-000-JSS-1543-001_D	D	JOB SPECIFICATION	122
080557C-000-ITP-1543-001_B	B	Inspection and Test Plan for On Off Valves	148
B366-999-YC-PTR-2451	B	PROVEN TRACK RECORD	153

# MATERIAL REQUISITION (TOP SHEET)

**ITEM DESCRIPTION: On-Off Valves**

**GROUP ITEM CODE 15EF**

**DESTINATION : IOCL PARADIP REFINERY**

**ITEM CATEGORY II**

**DELIVERY PERIOD :**

**DOCUMENT NUMBER**

(Always quote the Document Number given below as reference)

<b>B366</b>	<b>999</b>	<b>YC</b>	<b>MR</b>	<b>2451</b>	<b>B</b>
JOB NO	UNIT/	MAIN COST	DOC. CODE	SR.NO.	REV

<b>21/09/2021</b>	<b>16</b>	<b>51</b>
DATE	DIVN.	DEPT.
	ORIGINATOR	

**Notes:**

1. This page is a record of all Revisions of this Requisition
2. The nature of the Revision is briefly stated in the "Details" column below, the Requisition in its entirety shall be considered for contractual purpose.
3. Vendor shall note the MR category and shall submit his offer in line with the requirements included in attached 'Instructions to Bidders'

REV	DATE	BY	CHK	APPD	DETAILS
A	22/06/2021	AK	JJ	AR	Issued for Bids
B	21/09/2021	AK	JJ	AR	Re-Issued for Bids

This is a system generated approved document and does not require signature.

The drawing, design and details given on this format are the property of ENGINEERS INDIA LIMITED. They are merely loaned and on the borrower's express agreement that they will not be reproduced, copied, exhibited or used, except in limited way permitted by a written consent given by the lender to the borrower for the intended use. EIL-1641-515 Rev.1 A4-210x297



**ENGINEERS INDIA LIMITED**  
NEW DELHI

Project : IOCL Paradip SRU  
Client : IOCL

Sheet 1 Of 5

The drawing, design and details given on this format are the property of ENGINEERS INDIA LIMITED. They are merely loaned and on the borrower's express agreement that they will not be reproduced, copied, exhibited or used, except in limited way permitted by a written consent given by the lender to the borrower for the intended use. EIL-1641-515 Rev.1 A4-210x297

S.NO	TAG NO . / ITEM CODE	DESCRIPTION	QUANTITY	GROUP
1		Design ,engineering,manufacture,procurement of materials and bought out components, mandatory & commissioning spares, assembly at shop,inspection,testing at manufacturer's works, packing, delivery, documentation as per the enclosed instructions to vendors, job specification, data sheets etc		



Project : IOCL Paradip SRU  
Client : IOCL

REQUISITION No.

B366-999-YC-MR-2451

Sheet 2 Of 5

REV

B

The drawing, design and details given on this format are the property of ENGINEERS INDIA LIMITED. They are merely loaned and on the borrower's express agreement that they will not be reproduced, copied, exhibited or used, except in limited way permitted by a written consent given by the lender to the borrower for the intended use. EIL-1641-515 Rev.1 A4-210x297

S.NO	TAG NO . / ITEM CODE	DESCRIPTION	QUANTITY	GROUP
GROUP: 03 Plug Valves, Qty: 04 No's				
➤ 1.0006	088-XZV -0210	On Off Valve (Eccentric/Rotary plug, Fully Jacketed Type) 12"x10", 300#	1 Nos	03
➤ 1.0007	088-XZV -0211	On Off Valve (Eccentric/Rotary plug, Fully Jacketed Type) 10"X8",300#	1 Nos	03
➤ 1.0010	088-XZV -0221	On Off Valve (Eccentric/Rotary plug, Fully Jacketed Type) 8"X6",300#	1 Nos	03
➤ 1.0011	088-XZV -0222	On Off Valve (Eccentric/Rotary plug, Fully Jacketed Type) 8"X6",300#	1 Nos	03
<b>5</b>		<b>Supply of two years operation and Maintenance Spares,as per enclosed instructions to vendor</b>		
<b>6</b>		<b>Unit Rates</b>		
6.001		Unit Rates of items for addition/deletion purpose,as per the enclosed instructions to vendor.	1 Lot	
<b>8</b>		<b>Supervision of erection,testing and commissioning of items specified at item 1.00 above as per enclosed instructions to vendor</b>		
<del>➤ 8.0001</del>	<del>GRP 01</del>	<del>For Group 01</del>	<del>1 per diem</del>	<del>01</del>
➤ 8.0006	GRP 03	For Group 03	1 per diem	03
<del>➤ 8.0047</del>	<del>GRP 04</del>	<del>For Group 04</del>	<del>1 per diem</del>	<del>04</del>
<del>➤ 8.0048</del>	<del>GRP 02</del>	<del>For Group 02</del>	<del>1 per diem</del>	<del>02</del>
<p>➤ Vendors shall quote prices against these items in their price schedule Vendor to note that the numbers given in square '['] and curly '{} ' brackets are not for their use and meant for store purpose only.Items shall be tagged as per equipment Tag No. only.</p>				

 <b>ENGINEERS INDIA LIMITED</b> NEW DELHI	Project : IOCL Paradip SRU	REQUISITION No.	REV
	Client : IOCL	B366-999-YC-MR-2451 Sheet 3 Of 5	B

## LIST OF ATTACHMENTS

S. No.	DOCUMENT TITLE	DOCUMENT NO.	REV	DATE	SHEETS
1	Vendor Data Requirement	B366-999-YC-VD-2451	1	21/09/2021	3
2	Special Instruction to Vendor	B366-999-YR-SI-2451	1	21/09/2021	7
3	Compliance Statement	B366-999-YC-CF-2451	1	21/09/2021	1
4	Schematic for On Off Valve with 2 nos of Solenoid Valves	B366-999-YC-SK-2451	0	11/06/2021	1
5	Datasheet index with Datasheets	B366-999-YC-ID-2451	1	21/09/2021	98
6	Job specification for On Off Valves and MOV	080557C-000-JSS-1543-001	0	11/06/2020	26
7	Inspection and Test Plan for On Off Valves	080557C-000-ITP-1543-001	0	10/12/2019	5
8	Proven Track Record	B366-999-16-51-PTR-2451	1	21/09/2021	1

In case of any subsequent revision of MR or PR, only revised sheets of the attachments listed above shall be issued alongwith the revision.

**GENERAL NOTES:**



**ENGINEERS INDIA LIMITED**  
NEW DELHI

Project : IOCL Paradip SRU  
Client : IOCL

REQUISITION No.

B366-999-YC-MR-2451

Sheet 4 Of 5

REV

B



Engineers India Limited

# Vendor Drawing/ Document Submission Schedule

<b>Client/ Project:</b> IOCL/ IOCL Paradip SRU	<b>Vendor's Name :</b>	<b>Contact Person (Name/ Tel/ Fax/ email) :</b>	<b>Status Date:</b>
--	------------------------	---	---------------------

<b>Item Description:</b> On-Off Valves	<b>PR No.:</b>	<b>Review Status Code:</b> 1. No Comments 2. Proceed with manufacture/ fabrication as per commented document. Revised document required. 3. Document does not conform to basic requirements as marked. Resubmit for Review. R: Retained for Reference V: Void
	<b>Date of LOI:</b>	
	<b>PO No.:</b>	
	<b>Date of PO:</b>	

<b>EIL Originating Department :</b> Instrumentation	<b>Contact Person(EIL):</b>
---	-----------------------------

S.No.	Drg/ Doc. Nomenclature as per EIL Vendor Data Requirement	Vendor Drg/ Doc No.	Category Review(R)/ Records(I)	Schedule Date of 1st Submission (Rev. 0)	Anticipated (Ant) Date of submission by vendor					Form Electronic (E)/ Print (P)	Remarks
		Title			Actual (Act) Date of submission by vendor						
					Date of Return (Rew) by EIL						
					Review Status (Code)						
					Rev. 0	Rev. 1	Rev. 2	Rev. 3			
					<b>Ant</b>						
					<b>Act</b>						
					<b>Rew</b>						
					<b>Code</b>						
					<b>Ant</b>						
					<b>Act</b>						
					<b>Rew</b>						
					<b>Code</b>						
					<b>Ant</b>						
					<b>Act</b>						
					<b>Rew</b>						
					<b>Code</b>						

## VENDOR DATA REQUIREMENT

Description	With Proposal (Prints)	AFTER PURCHASE ORDER		Final Documentation / As Built
		Prints	Date Needed	
1. Dimensional details with mounting details and model number		X(i)	4W	
2. Connections by purchase(Piping,Electrical Etc.)		X(i)	4W	X
3. Wiring diagrams				X
4. Parts list				X
5. Recommended spare parts list(for two years operation )	X	X(i)	4W	X
6. Installation, Operation and maintenance manual		X(i)		X
7. Proven Track Record	X			
8. Filled in Datasheets as part of Offer	X			
9. Certificate from statutory body	X			X
10. Catalogues in english	X			X
11. Testing and Inspection procedures		X(a)	6W	
12. Compliance Statement	X			
13. Final Documentation in CD				X
14. Vendor Drawing Document Schedule		X(a)	1W	
15. Schematic for Pneumatic hookups		X(i)	4W	X
16. SIL certificate for Solenoid Valve & Limit Switch	X	X(i)	4W	X
17. Mandatory Spares & Commissioning Spares		X(a)	2W	

1	21/09/2021	AK	JJ	AR	REQ. NO. : B366-999-YC-MR-2451
0	22/06/2021	AK	JJ	AR	ORDER NO. :
REV	DATE	BY	CHKD	APPVD	VENDOR :

Page 1 Of 3



**ENGINEERS INDIA LIMITED**  
NEW DELHI

PLANT : IOCL Paradip SRU  
UNIT : 999  
CLIENT IOCL

SPECIFICATION  
B366-999-YC-VD-2451

REV  
1

The drawing, design and details given on this format are the property of ENGINEERS INDIA LIMITED. They are merely loaned and on the borrower's express agreement that they will not be reproduced, copied, exhibited or used, except in limited way permitted by a written consent given by the lender to the borrower for the intended use. EIL-1651-726 Rev.0 A4-210x297

# VENDOR DATA REQUIREMENT

**NOTES :**

1. Fold all drawings to 216mm X 279mm and roll transparencies.
2. Vendor to provide all printed matter to ENGINEERS INDIA LIMITED (EIL) / BHEL ATTENTION -

Vendor Drawing Control  
1, Bhikaji Cama Place, New Delhi-110066.

**LEGEND:**

Categories preceeded with \* will be approved for fabrication by Engineers India Limited / BHEL  
The remaining drawings are needed for information only.

A/C = As compiled A/R = As required W/S = With shipment W = Weeks

**IMPORTANT**

While submitting drawings and documents for review as indicated in vendor data requirement, vendor must ensure the following :

1. A blank space measuring 75 mm W x 38 mm H shall be provided on all vendor drawings (on the front side) for marking review codes etc. by ENGINEERS INDIA LIMITED./ BHEL
2. The review of the drawings shall be done as applicable, under the following review codes :
  - a) Review Code 1 : No Comments.
  - b) Review Code 2 : Proceed with manufacture / fabrication as per commented drawing.  
Revised drawing required.
  - c) Review Code 3 : Document does not conform to the basic requirements as marked.  
Resubmit for review.
3. Review of the vendor drawings by EIL / BHEL only to check compatibility with basic design and concepts and would in no way absolve the manufacturer / fabricator of his responsibility to meet the applicable codes, specifications and statutory rules and regulations.
4. For drawings / documents indicated as FOR INFORMATION in the vendor data requirement, vendor must clearly mark FOR INFORMATION ONLY on the submitted drawings / documents.
5. Any drawing/document not indicated in the list above but required during erection, commissioning or for reconfiguration of the system shall also be supplied by the Vendor on demand.
6. X indicates required. Suffix Codes mean the following:
  - (i) For Information
  - (a) For Approval
7. The soft copy of documentation shall be in editable form (CAD, Excel, Database etc ).
8. Note-1 & 2 above is not applicable as document shall be submitted as soft copies through eDMS / equivalent document exchange system.
9. Refer elsewhere in the RFQ for FINAL DOCUMENTATION procedure.
10. DCI shall be prepared by vendor based on the VDR attached with PR and submit within 15 days from the

1	21/09/2021	AK	JJ	AR	REQ. NO. : B366-999-YC-MR-2451
0	22/06/2021	AK	JJ	AR	ORDER NO. :
REV	DATE	BY	CHKD	APPVD	VENDOR :



**ENGINEERS INDIA LIMITED**  
NEW DELHI

PLANT : IOCL Paradip SRU  
UNIT : 999  
CLIENT IOCL

SPECIFICATION	REV
B366-999-YC-VD-2451	1

The drawing, design and details given on this format are the property of ENGINEERS INDIA LIMITED. They are merely loaned and on the borrower's express agreement that they will not be reproduced, copied, exhibited or used, except in limited way permitted by a written consent given by the lender to the borrower for the intended use. EIL-1651-726 Rev.0 A4-210x297

## VENDOR DATA REQUIRMENT

date of FOA.

11. Vendor shall submit the record/information category documents to Engineer In-charge with one copy through eDMS portal/ equivalent document exchange system to EIL/BHEL and vendor shall proceed further without waiting for comments from EIL/BHEL.

12. All inspection related document (QA/QC/ITP) shall be submitted to TPIA.

13. No of copies to be submitted to the site and owner shall be 6 hard copies along with 2 Nos CDs/DVD/Pendrive etc.

The drawing, design and details given on this format are the property of ENGINEERS INDIA LIMITED. They are merely loaned and on the borrower's express agreement that they will not be reproduced, copied, exhibited or used, except in limited way permitted by a written consent given by the lender to the borrower for the intended use. EIL-1651-726 Rev.0 A4-210x297

1	21/09/2021	AK	JJ	AR	REQ. NO. : B366-999-YC-MR-2451
0	22/06/2021	AK	JJ	AR	ORDER NO. :
REV	DATE	BY	CHKD	APPVD	VENDOR :

Page 3 Of 3



ENGINEERS INDIA LIMITED  
NEW DELHI

PLANT : IOCL Paradip SRU  
UNIT : 999  
CLIENT IOCL

SPECIFICATION	REV
B366-999-YC-VD-2451	1

**SPECIAL INSTRUCTION TO VENDORS**  
**(B366-999-YR-MR-2451)**

**JOB NO : B366**

**PROJECT : STANDBY SRU PROJECT, IOCL – PARADIP**

**CLIENT : INDIAN OIL CORPORATION LTD.**

This Package is applicable for Pneumatic operated on off Eccentric/Rotary Plug valves only. Bidders should ignore data related to other type of valves mentioned in this specification.

---

---

1	21.09.21	Re-Issued with MR	AK	JJ	AR
0	22.06.21	Issued with MR	AK	JJ	AR
<b>Rev. No</b>	<b>Date</b>	<b>Purpose</b>	<b>Prepared by</b>	<b>Checked by</b>	<b>Approved by</b>

---

**Part A:**

**I. BIDDING INSTRUCTIONS**

A1. Bidders must follow the following guidelines while submitting their offer. Offers not complying to these guidelines shall be rejected summarily without any intimation to the Bidder.

- a. Furnish quotations only for those items that bidder can supply strictly as per MR specifications
- b. In case of any contradiction between these bidding instructions and any other documents attached with the MR, this bidding instruction shall govern.

In case of contradiction, Purchaser's decision will be final.

c. Bidder shall submit the price details against each Group specified in this MR, in the separate price schedule sheet with unit rate. Accessories if any for a tag shall be indicated in the item summary and the price of the accessories shall be included in the base price of the Group itself. No information / description, technical or non-technical, other than what is required shall be filled or submitted. Unit rates of accessories if any, also to be provided separately. If any change at a later date is required in the range/ selection of accessories due to wrong selection, the same shall be borne by the vendor.

A2. Bidder is responsible to meet all technical requirements in Material Requisition including Instrument data sheets. If at any stage, till the completion of order, the offered instruments and its accessories are found unsuitable to meet the specification, Bidder shall replace the same with suitable items, without any time/Cost implication.

A3. In addition to the requirements specified above, Bidder must follow the following guidelines while submitting their offer.

a) The Material Requisition (MR) specifications (i.e. data sheets, Job specifications and other attachments to this MR) shall be fully complied with. No deviations of any type are acceptable. Bidder to offer only std. product out of their manufacturing range as listed in their product catalogue including valve model no., size etc. Valve with non std. model no., size shall not be accepted.

b) Bidder shall submit the itemwise price for valve, covering all the items, accessories, mandatory spares, testing, inspection and applicable statutory certification requirements as specified in this MR. If any change at a later date is required in the selection of accessories due to wrong selection, the same shall be borne by the vendor without any time or cost implication.

c) All documentation submitted by the bidder including their quotation, catalogues, drawings, installation, operation and maintenance manuals etc., shall be in English language only.

d) Unit rates for each valve and its accessories (Solenoid Valve, Partial Stroke Testing Device, Limit Switch) shall be provided separately for any addition/deletion. Bidder shall note that these unit rates are only for addition/deletion at a later date. Price for accessories, testing required with each item as per MR specifications shall be included in the item price in pricing schedule. Bidder shall also furnish unit rate of each type of valve accessories as per clause no. B5 of this SIV.

A4. During Offer as per VDR, Vendor shall furnish the filled in datasheets for inclusion in the PR.

A5. Bidder to note that prior to the submission of bids, bidder can seek any clarification/ confirmation if required as part of pre-bid clarification. Bidder shall ensure that MR is thoroughly scrutinized and both technical and commercial clarifications are resolved.

A6. The Bidder shall submit the required drawings/ documents as per the Vendor Data Requirements (VDR) enclosed with the MR.

**A7. MUST COMPLY REQUIREMENTS**

Offer must be complete in all respects complying fully with the MR requirements without exception. No price change, whatsoever, shall be allowed to the bidder after submission of bid.

PART-B  
SPECIFIC JOB REQUIREMENTS

B1. The On Off Valves covered in this MR is for IOCL PARADIP Refinery.

Refinery	Job Number	Unit Name	Unit Number	Licensed By
IOCL-Paradip	B366	SRU II	089	BLACK & VEATCH
		SRU III	088	BLACK & VEATCH
		TGTU	090	BLACK & VEATCH

The following definition shall apply in this requisition:

Owner: M/s Indian Oil Corporation Ltd (IOCL)

Consultant/ PMC: M/s Technip Energies

Purchaser/ LSTK Contractor: M/s Bharat Heavy Electricals limited (BHEL)

Engineering Sub Contractor: M/s Engineers India Ltd (EIL)

B2. Bidder to note the following with regard to ordering of the valves mentioned in the requisition. The On-off valves are divided into groups as detailed below. Ball Valves shall be of long pattern type.

~~Group-1 (Butterfly, Triple Offset Type) :- 9 Nos.~~

~~Group-2 (Ball Type) :- 32 Nos.~~

Group-3 (Plug type) :- 4 Nos

~~Group-4 (Ball Fully Jacketed type) :- 2 Nos~~

Bidder to note that the evaluation shall be carried out on bottom line basis (lump sum basis) for all the tags in a group as mentioned above including mandatory spares, accessories, testing, advance diagnostic software for PST and all other requirements of MR. Bidder shall note that all valves in a particular group will be ordered together on one vendor. Bidder to ensure their offering accordingly.

B3. Model Nos. for On Off valves being provided shall be field proven as per Clause 11.6 of Job Specification 080557C-000-JSS-1543-001.

ITEMS WITH PROTOTYPE DESIGNS OR ITEMS NOT MEETING PROVENNESS CRITERIA SPECIFIED ABOVE SHALL NOT BE CONSIDERED BY THE BIDDER.

Vendor shall submit document B366-999-16-51-PTR-2451 with all PTR for each type of valve offered to substantiate the same. Valves not having proven references in similar applications shall not be acceptable.

B4. Bidder shall furnish quotations only for those items that bidder has proven-ness for and can supply strictly as per MR specifications. However, if a bidder is not having proven-ness criteria as per clause B3 above, for any particular valve size and rating, bidder can quote for the same, provided their principal qualifies proven-ness criteria for those valves size and rating and in such case these valve shall be inspected by TPIA and supplied in fully assembled condition from the bidder's principal works.

B5. Bidder shall furnish Lumpsum price for each group separately. In addition, Bidder shall also furnish unit price for the following for addition/ deletion purpose:

- Air Filter Regulator
- Solenoid Valves
- Limit Switches
- Positioner (PST) device
- Other accessories like Air Lock Relays (Pneumatic Relays, Volume booster, Quick Exhaust etc.)each type as applicable



Bidder to note that the unit rates quoted for these items shall be valid till the execution of order.



B6. Purchaser may require the service of Bidder's specialist during commissioning for supervision of On Off Valves. Hence bidder must quote per diem rate for the visit of their specialist to IOCL Paradip for supervision of testing and commissioning of Valves at site. 02 Number of days of visit for each group shall be quoted by the bidder as optional price.

This is exclusively for commissioning assistance and does not include any visit by Bidder for malfunctioning of instrument or instrument not meeting the requirements as per specification.

**B7. SPECIFIC TEST REQUIREMENTS**

Bidder to note that the charges for all the applicable testing requirements as per Job Specification for On Off valves 080557C-000-JSS-1543-001 and 080557C-000-ITP-1543-001 shall be included in the valve base price.

B8. The Job Specification for On Off valves (080557C-000-JSS-1543-001) shall be read in conjunction with this 'Special Instructions to Vendor' and the datasheets enclosed in this Material Requisition. Discrepancies shall be brought to Purchaser and Purchaser's decision shall be final and binding without any implication.

B9. On-Off Valve accessories like Air Filter Regulators, Solenoid Valves, Limit switches, Positioners etc. shall be supplied in fully assembled conditions.

- i) Valve tubing for the valve/ actuator assemblies shall be 6 mm OD, 1 mm thick size, ASTM A269, AISI SS316 L Tube (as a minimum).
- ii) Tube fittings (Male connectors) shall be ANSI SS 316, flareless double compression type. The fitting / ferrule hardness shall be in the range of RB 85-90 so as to ensure a minimum hardness difference of RB 5 to 10 between tube and fittings. The ferrule shall be of stainless steel material.
- iii) Tubing of size higher than 6 mm OD if required by Bidder for proper actuation of actuator/ On-Off valves as per the stipulated stroke time in datasheets shall be provided by Bidder during detailed engineering. Accessories like Air Filter Regulator shall be selected to match the air tubing requirements. This shall have no price or delivery implication.

B10. Bidder shall indicate the recommended actuator orientation direction. The orientation of the actuator may be changed after order. The bidder shall do the same without any price implication

B11. Where Flanged Butterfly valves are specified in the MR, Body material, body & flange rating shall be as mentioned in the datasheets attached with MR. However body and inlet and outlet flange rating shall be minimum 300#.

a) For On Off valves where body material has been specified as ASTM A216 Gr.WCB, ASTM A216 GR.WCC is also acceptable. Bidder shall also note that body material with forged materials are also acceptable subject that the materials are equivalent to Cast materials as per ASTM.

B12. Bidder shall supply air filter regulators as per datasheet no. B366-999-YC-DS-3003 attached with this MR. Quantity shall be as per individual data sheet only. Air filter regulators shall be supplied from the following Vendors only.

- |  |                       |
|--|-----------------------|
| a. CLARK RELIANCE CORPORATION          | INTERNATIONAL         |
| b. DONALDSON (INDIA)                   | INDIA                 |
| c. DONALDSON FILTRATION (THAILAND) LTD | INTERNATIONAL         |
| d. EKOPLANT                            | INTERNATIONAL         |
| e. MARSH BELLOFRAM                     | INDIA                 |
| f. MIKROPUL AUSTRALIA PTY LTD          | INTERNATIONAL         |
| g. PALL                                | INDIA / INTERNATIONAL |
| h. PARKER FILTRATION CANADA INC        | INTERNATIONAL         |
| i. PARKER HANNIFIN CORPORATION         | INTERNATIONAL         |
| j. PLACKA INSTRUMENTS INDIA P LTD      | INDIA                 |
| k. SCHRADER DUNCAN LIMITED             | INDIA                 |
| l. SHAVO NORGREN (I) PVT LTD           | INDIA                 |

B13 Bidder shall supply Solenoid valves as per datasheet no. B366-999-YS-DS-3004 attached with this MR. All Solenoid Valves shall be SIL-3 certified. Cable entry shall be 1/2" NPTF. Pilot Solenoid Valves are to be avoided and Direct acting Solenoid Valves shall only be considered.

Quantity shall be as per individual datasheet. Solenoid Valves shall be supplied from the following Bidders only.

- |    |  |                       |
|----|--|-----------------------|
| a. | ALCON ALEXANDER CONTROLS LIMITED   | INTERNATIONAL         |
| b. | ASCO JOUCOMATIC LTD  | INDIA / INTERNATIONAL |
| c. | ASCO NUMATICS (INDIA) P. LIMITED   | INDIA                 |
| d. | AVCON CONTROLS PVT LTD   | INDIA                 |
| e. | HERION WERKE   | INDIA                 |
| f. | PRECISION INSTRUMENT COMPANY   | INDIA                 |
| g. | RMEBS CONTROLS PVT. LTD<br>(Old name: Rotex manufacturers and engineers Pvt Ltd) | INDIA                 |
| h. | SCHRADER DUNCAN LIMITED  | INDIA                 |
| i. | THOMPSON VALVES LTD  | INTERNATIONAL         |
| j. | VERSA BV   | INTERNATIONAL         |

**B14. . Limit Switches**

- (i) Limit switches shall be inductive proximity type and these shall meet NAMUR (DIN-19234) requirements. Refer datasheet no. B366-999-YI-DS-7001 for detailed specification of limit switches.
  - (ii) All limit switches in the electrically classified hazardous area in the field shall be certified intrinsically safe & Proximity type. Also, all limit switches shall be certified weather proof to IP-65 as a minimum.
  - (iii) Separate limit switches shall be provided for open and close position of the on-off valves
- All Limit Switches shall be minimum SIL 2 certified

**B15. PARTIAL STROKE TESTING POSITIONER:**

The Partial Stroke Testing positioners (PST) shall be on HART protocol & shall be connected through 4-20 mA HART AO card of Purchaser's DCS for communicating with the Purchaser's Instrument Asset Management System (IAMS). The PST shall carry out the partial stroking of the valve on receiving the command from Purchaser's IAMS either manually or automatically on pre-set regular intervals & send the Valve partial stroking feedback signal to the Purchaser's IAMS. Refer Doc No 080557C-000-JSS-1543-001 for details.

Any additional hardware/ accessories/ licensed software required for the PST for communicating with Purchaser's IAMS system as mentioned above & required to be located in the Control room shall also be supplied by the Bidder without any implication.

The positioners shall be HART-7 certified.

Software for partial stroke testing positioner with 1 no. of license for each group (license shall be suitable for all tags in that group) shall be considered by bidder and price for the same shall be included in the respective group price.

Bidder to provide PST from the following Make only:

- |    |                                    |                      |
|----|------------------------------------|----------------------|
| 1. | M/s METSO AUTOMATION               | INTERNATIONAL        |
| 2. | M/s DRESSER                        | INTERNATIONAL        |
| 3. | M/s FISHER (EMERSON)               | INDIA/ INTERNATIONAL |
| 4. | M/s SAMSON CONTROLS PVT LTD        | INDIA                |
| 5. | M/s FLOWERVE INDIA CONTROL PVT LTD | INDIA                |

Price for the requirements as mentioned above shall be included as part of base price against each group in respective valve tag.

**B16. Inspection and Test requirements:**

a) All the items supplied / integrated by the bidder at his works shall be subject to inspection at bidder's works by Third Party Inspection Agency (TPIA) appointed by M/s BHEL.

b) As a minimum, the inspection and testing requirements as per Job Specification for On Off Valves (080557C-000-JSS-1543-001) and Inspection Test Plan for On Off Valves (080557C-000-ITP-1543-001) attached along with the MR shall be adhered to.

B17. Bidder shall furnish a separate quote for spare parts for the On Off valves and their accessories for 2 years of normal operation separately as recommended by Bidder.

However, the same shall include plug, seat ring, gasket set, packing set, diaphragm, O-ring set etc as a minimum. Bidder shall provide list in tabular form indicating the common spares size, materials, model no. wise applicable for offered tags for each combination. Price for the same will not be considered for evaluation.

B18. Bidder to note that the drawing/documents to be submitted by bidder after purchase order as per VDR shall be for information category and for reference for further engineering by EIL/BHEL and bidder shall be responsible for completeness and correctness of the same. The specifications shall be as per MR only.

B19. Bidder to ensure that submission of all drawings / documents mentioned in VDR shall be in soft copies through eDMS/ equivalent document exchange system only during detail engineering & no document shall be submitted through hard copies However, as built document shall be submitted in hard copy along with soft copy.

B20. All valves must comply with fugitive emission requirement as per leakage class - C of ISO-15848-1.

B21. Wherever Soft Seat is specified in the datasheet with Class VI TSO and hardened trim is also specified, vendor to ensure suitable trim material for meeting both the requirements.

B22. MANDATORY SPARES:

Bidder shall supply the following mandatory spares for each group. Price for the same shall be included in the lumpsum price of each group.

- a) 20% of total quantity or minimum of 2 no. which ever is higher of each type of Air filter regulators for each group.
- b) 10% of total quantity or minimum of 1 no. which ever is higher of each type, size, rating of Trim set consisting of seat, seat ring / Seal ring, ball/ disc with stem for each group.
- c) 10% of total quantity or minimum of 1 no. which ever is higher of each type of Seal kit consisting of O rings, gaskets, gland packing etc. against each type, size and rating of valve for each group.
- d) 20% of total quantity or minimum of 1 no. which ever is higher of each type of limit switches for each group.
- e) 20% of total quantity or minimum of 2 no. which ever is higher of each type of solenoid valves for each group.
- f) 10% of total quantity or minimum of 1 no. which ever is higher of each type of accessories like quick exhaust valves, volume boosters and temperature dependent fuses, O rings of Actuators etc for each group.
- g) 10% (subject to minimum of 1 no., whichever is higher) of Bonnet, Gaskets, gland packings, piston O-rings, bearing & liner (of butter-fly valves) for all types of valves
- h) 20% or minimum two set of actuator seal kits which ever is higher for butterfly type valves.

B23. Bidder shall consider the following items as part of commissioning spares. Price for the same shall be considered in the lumpsum price of each group.

- (i) Gaskets: 1 set for each type, size and rating
- (ii) Gland Packings: 1 set for each type, size and rating

B24. All ball valves covered in this MR shall be of Long body design.



**B25. SITE CONDITIONS:**

The Valves and accessories covered in the MR s shall be suitable for unprotected installation in Hot, Humid and Corrosive environment having following ambient condition. The site environmental conditions are as follows:

<b>IOCL-Paradip Refinery</b>	
Maximum ambient temperature	42.4 † C
Minimum ambient temperature	11.3 † C
Relative humidity	95% (max) @ 42.4 ºC
Maximum recoded rainfall	335 mm in 24 hour

B.26 In case product/component is imported, bidder shall hire customer/PMC approved Third Party Inspection Agency (TPIA) for inspection at overseas location. Charges of such TPIA shall be borne by the bidder. Name of customer/PMC approved TPIA for inspection at abroad are given below..

- a. M/s TUV SUD South Asia Pvt. Ltd.
- b. M/s Apave Assessments India Pvt. Ltd.
- c. M/s VCS Quality Services Private Limited.
- d. M/s DNV GL Business Assurance India Pvt. Limited.
- e. M/s IR Class systems and Solutions Pvt. Ltd.
- f. M/s Projects and Development India Ltd.
- g. M/s TATA Project Limited.
- h. M/s Lloyds Register Asia.
- i. M/s Certification Engineers International Limited.
- j. M/s Bureau Veritas (India) Pvt. Ltd.
- k. M/s TUV India Pvt. Ltd.

For Third Party Inspection in India, BHEL shall be borne the TPIA charges.

**TECHNICAL COMPLIANCE STATEMENT**

(TO BE SIGNED BY VENDOR'S PRINCIPAL CORPORATE LEVEL SIGNATORY ON COMPANY LETTERHEAD)

I, ON BEHALF OF M/s \_\_\_\_\_ CONFIRM THAT THE PROPOSAL OF -----  
-----QUOTED BY M/s \_\_\_\_\_ **FOR SRU STANDBY  
TRAIN, IOCL PROJECT AT PARADIP OF M/S INDIAN OIL CORPORATION LIMITED**  
AGAINST MATERIAL REQUISITION /TENDER/PACKAGE No. -----  
----- IS IN TOTAL COMPLIANCE TO THE FOLLOWING

- A. SCOPE OF SUPPLY AND WORK
- B. TECHNICAL AMENDMENT IF APPLICABLE
- C. ANY OTHER DOCUMENT ATTACHED AS PART OF MR

**AS WELL AS ALL THE TECHNICAL SPECIFICATION AND NO DEVIATION, VARIATION OR RESERVATION WHATSOEVER HAS BEEN MENTIONED IN THE TECHNICAL OFFER.** IT IS FURTHER AGREED THAT THE TECHNICAL DETAILS FURNISHED IN OUR OFFER WILL BE REVIEWED BY BHEL/EIL/IOCL DURING DETAILED ENGINEERING STAGE AFTER ORDER AND ANY CHANGE REQUIRED TO MEET THE REQUIREMENTS OF ENQUIRY SCOPE AND SPECIFICATION INCLUDING AMENDMENT(S) (IF ANY) WILL BE INCORPORATED BY US WITHOUT ANY PRICE AND TIME IMPLICATION.

(SIGNATURE WITH SEAL)

## SCHEME -2

### 2oo2 SOLENOID BLOCK WITH SOLENOID VALVE LOCAL STATUS INDICATION AND INDIVIDUAL ISOLATION

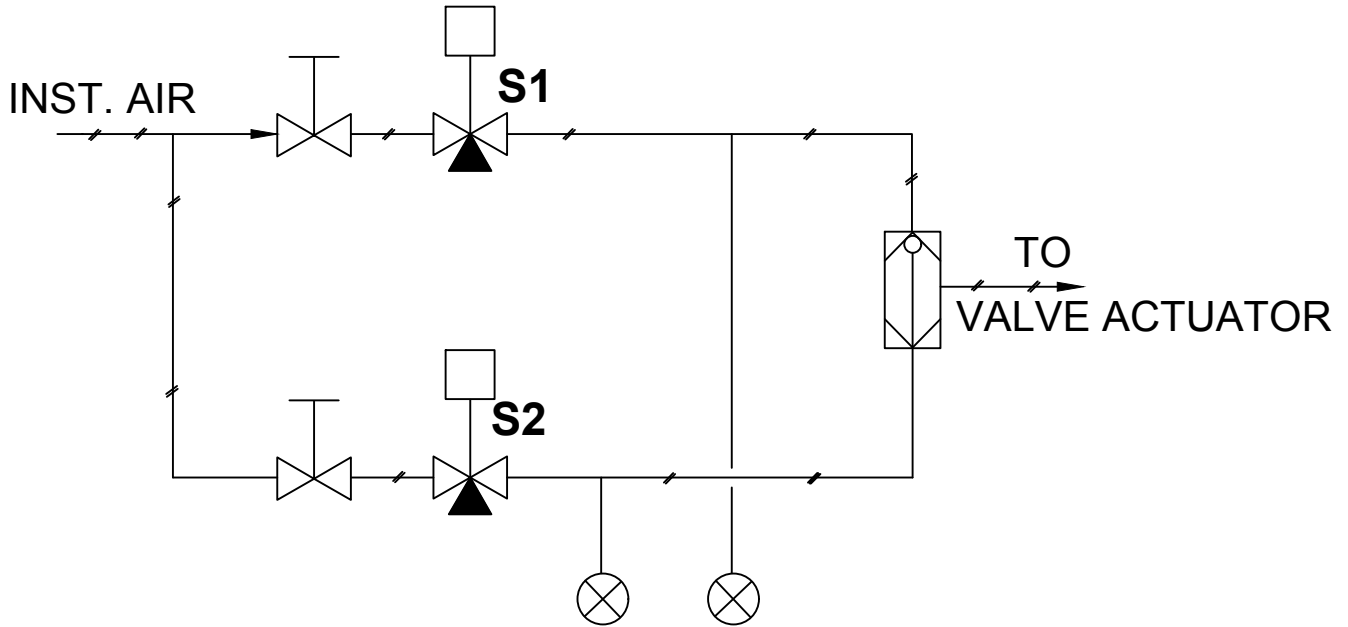

#### LEGEND:-

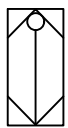

SHUTTLE VALVE

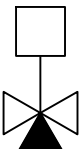

SOLENOID VALVE



ISOLATION VALVE(CSO)



SOV LOCAL STATUS INDICATION

#### NOTES:-

1. ALL THE BLOCKS SHALL BE STANDARD PRE-ASSEMBLED AND PRE-TESTED. SHALL BE PROVIDED WITH STANDARD ELECTRICAL CONNECTION TERMINAL BLOCK. NO FLYING LEADS ACCEPTABLE.
2. ALL SOLENOID VALVES ARE LOW POWERED 24 VDC INTRINSICALLY SAFE DRIVEN BY IS ISOLATOR
3. SIL CERTIFICATES WHEREVER REQUIRED FOR THIS BLOCK SHALL BE PROVIDED.



**ENGINEERS INDIA LIMITED**  
NEW DELHI

**SCHEME -2**

**STANDARD**

**REV.**

**B366-999-YC-SK-2451**

**0**

SHT. 1 OF 1

## Air Filter Regulator-Non Tag Item

GENERAL	1.	Regulator Requirement			Filter Regulator with Gauge	Self Reg., Intermittent Blee
	2.	Fluid			Instrument Air	
	3.	Inlet Pressure	Min	Max		
	4.	Outlet Pressure	Normal			
	5.	Adjustable Range	Min	Max		
	6.	Output Gauge			Required	
		Output Gauge Size		mm	50	
	7.	Range of the Gauge	Min	Max		
	8.	Range Adjustment			Hand wheel with Lock Nut	
	9.	Drain Cock			Required	
	10.	Connection Size			1/4" NPT(F)	
	11.	Enclosure			IP66	
	12.	Regulation Characteristics				
		Type				
		Outlet Pressure Limit		%	10	
		For Flow variations				
		Minimum				
	Maximum					
	For inlet Pressure variations					
	Minimum					
	Maximum					
MATERIAL	13.	Body			SS316	
		Bowl			Metallic	
		Filter			5 µm Sintered Bronze	
		Diaphragm			Reinforced Neoprene	
		Inner Valve Assembly			SS 316	
OPTIONS		Spring			Plated Steel	
	14.	Mounting Accessories			Required	
OTHERS	15.	Drain plug / Spindle			Required	
	16.	Manufacturer				
	17.	Model No				

**NOTES:**

- General: 1 Quantity shall be as per Valve Data sheets attached with this MR.
- S. No. 3 : Inlet pressure Minimum/Normal/Maximum : 3.5/ 5.2/10 Kg/cm2(g) respectively.
- S. No. 4 : Outlet Pressure for Air filter Regulators (AFR) shall be as required by On Off Valve Vendor.
- S. No. 5 : As per the requirements indicated against S.No.4.
- S. No. 7 : As per requirements indicated against S. No 5.
- S. No.12 :Downstream regulator type to be provided. Minimum & Maximum Flow variation are 3 & 300 L/min respectively.
- S.No. 15 : Adjustment spindle with nut and drain shall be of SS material.
- 2. Air Filter regulator shall have 5 micron filters

Sheet 1 Of 1

0	27/05/2021	AK			REQUISITION NO :	LEGEND :    □ Hold * By Vendor ^ Data Revised
					ORDER NO. :	
REV	DATE	BY	CHKD	APPVD	VENDOR :	



**ENGINEERS INDIA LIMITED**  
NEW DELHI

PLANT : IOCL Paradip SRU  
UNIT : 999

SPECIFICATION

REV

B366-999-YC-DS-3003

0

## Solenoid Valve - Non Tag Item

The drawing, design and details given on this format are the property of ENGINEERS INDIA LIMITED. They are merely loaned and on the borrower's express agreement that they will not be reproduced, copied, exhibited or used, except in limited way permitted by a written consent given by the lender to the borrower for the intended use. EIL-1651 - Rev. A4-210x297

	VALVE BODY	HAZ. LOC.	SOLENOID	FLUID DATA	
1.	Type			19.	Fluid
2.	Body Size inch			20.	Pressure kg/cm <sup>2</sup> (g)
3.	Port Size inch				Operating
4.	End Connection				Maximum
5.	Material			21.	Temperature °C
	Body				Operating
	Trim				Maximum
6.	Body Rating kg/cm <sup>2</sup>			22.	Maximum Flow kg/h
7.	Action			23.	Relative Density
8.	Operation			24.	Relative Mol Mass
9.	Packing			25.	Viscosity mPa.s
10.	Electrical Area Classification			26.	Oper. Diff. kg/cm <sup>2</sup>
11.	Enclosure				Minimum
12.	Intrinsic Safety				Maximum
13.	Type Of Energisation			27.	Max. Allowable Differential kg/cm <sup>2</sup>
14.	Power Supply			28.	Shutoff Diff. kg/cm <sup>2</sup>
	Energisation			29.	Value CV
	Dropout			30.	Manufacturer
	Frequency			31.	Model No.
15.	Power Consumption VA				
16.	Inrush Current A				
17.	Type of Coil				
	Style of Coil				
	Insulation Class				
18.	Pulse Duration s				

- Options :
- |   |  |
|---|--|
| a)Control Room Manual Reset (CMR)               | b)Field Manual Reset (FMR) with Lever Type |
| c)Field Manual Reset (FMR) with Pushbutton Type | d)Latching On Energise                     |
| e)Latching On De-Energise                       | f) CCOE Approval                           |

Notes : The term 'Normally Open/Closed' implies Solenoid Valve under de-energised condition.

1. The quantity of solenoid valves shall be as specified in the corresponding Valve datasheet in attached with this MR.
2. Flying leads not acceptable, suitable terminal blocks shall be provided for cable termination.
3. SOV to be designed for design pressure of 10 kg/cm<sup>2</sup>(g) of air. Min air pressure shall be 3.5 kg/cm<sup>2</sup>(g).
4. SOVs shall be weather proof to IP-66 and Intrinsically Safe for the given area classification. Certificates to this effect shall be furnished from a statutory body like FM/UL/Baseefa etc. In addition PESO/CCOE approved certificates shall be furnished by the vendor.
5. Cable entry shall be 1/2" NPTF.
6. OPTION required : f
7. All Solenoid valves shall be Auto Reset Type.
8. Solenoid valve shall be low power consumption type , suitable for operating with intrinsic safe isolator (P&F make barrier Model No KFD2-SL2-Ex1.LK) and considering a cable resistance of 7.4 ohms/km with 2.5 mm<sup>2</sup> cable at a distance of 500 m from Control Room.
9. Solenoid valves shall be full port type and solenoid valve orifice shall be approximately equal to the inlet air tubing size to facilitate quick opening.
10. All SOV shall be 100l but model shall be certified for use in SIL-3 application.
11. Vent port of all solenoid valves are to be provided with SS/ Brass bug screens, to prevent blockage of port because of bugs and to save the port from dust. All such bug screens are to be checked for blockage at regular intervals.
12. S. No 1: Four way Solenoid Valves shall be provided if double acting piston type actuator is provided.
13. S. No 2: Higher tubing size of 1/4" may be provided based on interconnecting tubing size, in case required by vendor.

Sheet 1 Of 1

0	27/05/2021	AK			REQUISITION NO :	LEGEND : ☒ Hold * By Vendor ^ Data Revised	
					ORDER NO. :		
REV	DATE	BY	CHKD	APPVD	VENDOR :		
<b>ENGINEERS INDIA LIMITED</b> NEW DELHI					PLANT : IOCL Paradip SRU UNIT : 999 CLIENT: IOCL	SPECIFICATION	REV
						B366-999-YS-DS-3004	0

## Limit Switches - Non Tag Item

The drawing, design and details given on this format are the property of ENGINEERS INDIA LIMITED. They are merely loaned and on the borrower's express agreement that they will not be reproduced, copied, exhibited or used, except in limited way permitted by a written consent given by the lender to the borrower for the intended use.







General	1.	Type	Unit	Proximity type switches as per DIN 19234	
Haz.Location	2.	Electrical Area Classification		Zone-1 Gr. IIA & IIB	
Switch	3.	Hysterisis			
	4.	Form		Proximity	
	5.	Enclosure Type		IP66	
	6.	Mounting		On the valve	
	7.	Type of Protection		Intrinsically safe	
	8.	Power Supply		24VDC(thru IS barrier cum Amp)	
	9.	Contact Rating		0.5 A	
	10.	Cable Entry	Power	Signal	
Options	11.	IS Barrier	Type	By Purchaser	NA
	12.	Switching Amplifier			
		Type	Contact Rating	NA	NA
	13.	Contact Status Before Actuation			
	14.	Contact Status After Actuation			
	15.	Mounting Accessories			
Certification	16.	Statutory		PESO	
	17.	Others			
Others	18.	Model No.			
	19.	Make			

**Notes :**



1. Quantity and Tag Nos. shall be as per Individual Valve Data Sheet attached with this MR.
2. Vendor shall provide separate switches for open and close positions wherever applicable as per datasheet.
3. For cable connections, flying leads are not acceptable. Suitable terminal blocks shall be provided for cable termination.
4. The limit switches shall be Weather proof to IP 66 / NAMUR Standard and Intrinsically safe. Certificates to this effect indicating the entity parameters shall be furnished from statutory body.
5. All Limit switches shall be minimum SIL-2 certified.







Sheet 1 Of 1

0	27/05/2021	AK			REQUISITION NO :	LEGEND :    □ Hold * By Vendor ^ Data Revised	
					ORDER NO. :		
REV	DATE	BY	CHKD	APPVD	VENDOR :		
<b>ENGINEERS INDIA LIMITED</b> NEW DELHI					PLANT : IOCL Paradip SRU UNIT : 999 CLIENT : IOCL	SPECIFICATION B366-999-YI-DS-7001	REV 0



GENERAL	1	Tag No.	088-XZV -0210																																																																																																																																													
	2	Service	OUTLET SULFUR VAPOR ON-OFF VALVE																																																																																																																																													
	3	Line No.	10"-P-088-3201-A15A-IJ																																																																																																																																													
	4	Area Classification	Zone-1 Gr. IIA & IIB, T3																																																																																																																																													
	5	Ambient Temperature:	Min.	Max.	°C °C																																																																																																																																											
	6	Allowable Sound Pressure Level	dBA																																																																																																																																													
	7	Control Action- On-Off (or) Modulating	On Off																																																																																																																																													
	8	Available Air Supply Pressure:	Min.	Max.	kgf/cm <sup>2</sup> -g kgf/cm <sup>2</sup> -g																																																																																																																																											
	9	Failure Position	Close																																																																																																																																													
PIPE LINE	10																																																																																																																																															
	11	Line Size and Schedule	10 in STD																																																																																																																																													
PROCESS CONDITIONS	12	Inlet Line ID (inch)	Outlet Line ID (inch)																																																																																																																																													
	13																																																																																																																																															
	14	Process Fluid	Fluid State	Fluid Phase																																																																																																																																												
	15	% Flash	% Solids																																																																																																																																													
	16	Differential Pressure-Shut Off	7 kgf/cm <sup>2</sup>																																																																																																																																													
	17		Units	@ Max. Flow	@ Norm. Flow @ Min. Flow																																																																																																																																											
	18	Flow Rate																																																																																																																																														
	19	Inlet Pressure	kgf/cm <sup>2</sup> -g																																																																																																																																													
	20	Pressure Drop	bar																																																																																																																																													
	21	Inlet Temperature	°C																																																																																																																																													
	22	Inlet Density / Specific Gravity / Molecular Mass	kg/m <sup>3</sup>																																																																																																																																													
	23	Inlet Compressibility Factor	-																																																																																																																																													
	24	Inlet Viscosity	cP																																																																																																																																													
	25	Inlet Specific Heat Ratio	-																																																																																																																																													
	26	Inlet Vapour Pressure																																																																																																																																														
	27	Critical Pressure																																																																																																																																														
	CALCULATED RESULTS	28	Flow Coefficient Cv	Max.	Nor	Min.																																																																																																																																										
29		Travel	Inlet Velocity % m/sec																																																																																																																																													
BODY AND TRIM	30	Sound Pressure Level	dBA																																																																																																																																													
	31	MFR	Model	*	*																																																																																																																																											
	32	Body Type	Eccentric / Rotary Plug																																																																																																																																													
	33	Body Size	Port Size	10 in	FULL																																																																																																																																											
	34	Rated Cv	Characteris.	*																																																																																																																																												
	35	End Connec. & Rating	12" x 10" , 300#																																																																																																																																													
	36	Facing and Finish	RF 125AARH																																																																																																																																													
	37	Body, Bonnet Material	ASTM A216 Gr WCB																																																																																																																																													
	38	Packing Material	Graphite																																																																																																																																													
	39	Rated Travel	MFR STD																																																																																																																																													
	40	Lubricator	Isolat. Valve																																																																																																																																													
	41	Guiding	No. of Ports																																																																																																																																													
	42	Trim Type																																																																																																																																														
	43	Trim Material	SS 316																																																																																																																																													
	44	Other Wetted Parts Material	*																																																																																																																																													
	ACTUATOR	45	Soft Seat	Material	Metal Seat	*																																																																																																																																										
		46																																																																																																																																														
47		Gasket Material	Spiral Wound Gasket SS316																																																																																																																																													
48		Bonnet Type	Mfr Std																																																																																																																																													
49		MFR	Model	*	*																																																																																																																																											
50		Type	Pneumatic Piston Actuator																																																																																																																																													
51		Size	Area																																																																																																																																													
52		Air Failure Valve:																																																																																																																																														
53		Handwheel Location	NO																																																																																																																																													
54		Bench Range																																																																																																																																														
55	Spring Action	FAIL CLOSE																																																																																																																																														
Notes:																																																																																																																																																
<table border="1"> <tr> <td>56</td> <td>MFR</td> <td>Model</td> <td>*</td> <td>*</td> </tr> <tr> <td>57</td> <td>Signal: Inlet</td> <td>Outlet</td> <td colspan="2">4-20mA</td> </tr> <tr> <td>58</td> <td>Type</td> <td colspan="3">SMART, HART</td> </tr> <tr> <td>59</td> <td>Air Supply Pressure</td> <td colspan="3">3.5 kg/cm<sup>2</sup>-g</td> </tr> <tr> <td>60</td> <td>Bypass</td> <td>Gauges</td> <td>No</td> <td>2 No's</td> </tr> <tr> <td>61</td> <td>I/P Converter</td> <td colspan="3"></td> </tr> <tr> <td>62</td> <td>Silencer Exp Baffle Plate</td> <td colspan="3"></td> </tr> <tr> <td>63</td> <td>Pneu. Lock Relay/Vol. Bos</td> <td colspan="3"></td> </tr> <tr> <td>64</td> <td>Type</td> <td colspan="3">3 WAY Universal</td> </tr> <tr> <td>65</td> <td>When De-Enegr.Valve:</td> <td colspan="3"></td> </tr> <tr> <td>66</td> <td>Tag No.</td> <td colspan="3">088-XZY-0210</td> </tr> <tr> <td>67</td> <td>MFR</td> <td>Model</td> <td>*</td> <td>*</td> </tr> <tr> <td>68</td> <td>Type</td> <td>Quantity</td> <td>Proximity</td> <td>2 no's.</td> </tr> <tr> <td>69</td> <td>Voltage</td> <td colspan="3">24V DC</td> </tr> <tr> <td>70</td> <td>Switching Position</td> <td colspan="3">FULL OPEN/ FULL CLOSE</td> </tr> <tr> <td>71</td> <td>Tag No.</td> <td colspan="3">088-ZSL/ ZSH-0210</td> </tr> <tr> <td>72</td> <td>MFR</td> <td>Model</td> <td>*</td> <td>*</td> </tr> <tr> <td>73</td> <td>Set Pressure</td> <td colspan="3"></td> </tr> <tr> <td>74</td> <td>Filter</td> <td>Gauge</td> <td>Required</td> <td>Yes, 1 no.</td> </tr> <tr> <td>75</td> <td>MFR</td> <td>Model</td> <td>*</td> <td>*</td> </tr> <tr> <td>76</td> <td>Leakage Class</td> <td colspan="3">CLASS V , TSO</td> </tr> <tr> <td>77</td> <td>IBR</td> <td>Hydrogen</td> <td>YES</td> <td></td> </tr> <tr> <td>78</td> <td>Req. Number</td> <td colspan="3"></td> </tr> <tr> <td>79</td> <td>Manufacturer</td> <td colspan="3">*</td> </tr> <tr> <td>80</td> <td>Model</td> <td colspan="3">*</td> </tr> <tr> <td>81</td> <td>Purchase Order Num.</td> <td colspan="3">B366-999-YC-MR-2451</td> </tr> <tr> <td>82</td> <td>Price</td> <td>Item Number</td> <td colspan="2"></td> </tr> <tr> <td>83</td> <td>Serial Number</td> <td colspan="3"></td> </tr> </table>					56	MFR	Model	*	*	57	Signal: Inlet	Outlet	4-20mA		58	Type	SMART, HART			59	Air Supply Pressure	3.5 kg/cm <sup>2</sup> -g			60	Bypass	Gauges	No	2 No's	61	I/P Converter				62	Silencer Exp Baffle Plate				63	Pneu. Lock Relay/Vol. Bos				64	Type	3 WAY Universal			65	When De-Enegr.Valve:				66	Tag No.	088-XZY-0210			67	MFR	Model	*	*	68	Type	Quantity	Proximity	2 no's.	69	Voltage	24V DC			70	Switching Position	FULL OPEN/ FULL CLOSE			71	Tag No.	088-ZSL/ ZSH-0210			72	MFR	Model	*	*	73	Set Pressure				74	Filter	Gauge	Required	Yes, 1 no.	75	MFR	Model	*	*	76	Leakage Class	CLASS V , TSO			77	IBR	Hydrogen	YES		78	Req. Number				79	Manufacturer	*			80	Model	*			81	Purchase Order Num.	B366-999-YC-MR-2451			82	Price	Item Number			83	Serial Number			
56	MFR	Model	*	*																																																																																																																																												
57	Signal: Inlet	Outlet	4-20mA																																																																																																																																													
58	Type	SMART, HART																																																																																																																																														
59	Air Supply Pressure	3.5 kg/cm <sup>2</sup> -g																																																																																																																																														
60	Bypass	Gauges	No	2 No's																																																																																																																																												
61	I/P Converter																																																																																																																																															
62	Silencer Exp Baffle Plate																																																																																																																																															
63	Pneu. Lock Relay/Vol. Bos																																																																																																																																															
64	Type	3 WAY Universal																																																																																																																																														
65	When De-Enegr.Valve:																																																																																																																																															
66	Tag No.	088-XZY-0210																																																																																																																																														
67	MFR	Model	*	*																																																																																																																																												
68	Type	Quantity	Proximity	2 no's.																																																																																																																																												
69	Voltage	24V DC																																																																																																																																														
70	Switching Position	FULL OPEN/ FULL CLOSE																																																																																																																																														
71	Tag No.	088-ZSL/ ZSH-0210																																																																																																																																														
72	MFR	Model	*	*																																																																																																																																												
73	Set Pressure																																																																																																																																															
74	Filter	Gauge	Required	Yes, 1 no.																																																																																																																																												
75	MFR	Model	*	*																																																																																																																																												
76	Leakage Class	CLASS V , TSO																																																																																																																																														
77	IBR	Hydrogen	YES																																																																																																																																													
78	Req. Number																																																																																																																																															
79	Manufacturer	*																																																																																																																																														
80	Model	*																																																																																																																																														
81	Purchase Order Num.	B366-999-YC-MR-2451																																																																																																																																														
82	Price	Item Number																																																																																																																																														
83	Serial Number																																																																																																																																															
<table border="1"> <tr> <td colspan="4">INSTRUMENT SPECIFICATION</td> <td rowspan="2">   </td> </tr> <tr> <td colspan="4">ON OFF VALVE</td> </tr> <tr> <td colspan="4">Project: BHEL IOCL PARADIP</td> </tr> <tr> <td colspan="4">Job No : B366</td> </tr> <tr> <td colspan="4">Unit No.:088- SRU 3</td> </tr> <tr> <td colspan="2">Sheet 1</td> <td colspan="2">of 2</td> </tr> </table>					INSTRUMENT SPECIFICATION				 	ON OFF VALVE				Project: BHEL IOCL PARADIP				Job No : B366				Unit No.:088- SRU 3				Sheet 1		of 2																																																																																																																				
INSTRUMENT SPECIFICATION				 																																																																																																																																												
ON OFF VALVE																																																																																																																																																
Project: BHEL IOCL PARADIP																																																																																																																																																
Job No : B366																																																																																																																																																
Unit No.:088- SRU 3																																																																																																																																																
Sheet 1		of 2																																																																																																																																														
No.	By	Date	Revision	Code: 73	Doc. No.: B366-088-YC-DS-3218	Rev.: 1																																																																																																																																										

1. " \* " indicates data to be furnished by Vendor.
2. Partial Stroke testing (PST) device is required as per specifications mentioned in 080557C-000-JSS-1543-001.  
Tag No. shall be 088-PST-0210.
3. Bolting Material shall be ASTM A193 Gr. B7 for Bolts & A194 Gr. 2H for Studs Nuts.
4. Design Conditions:  
Design Pressure (Max/) : 7 kg/cm2g  
Design Temperature (Max): 240°C
5. Valve closing time : Within 10 sec
6. IBR requirement as per CI No. 10.10 of Doc. No. 080557C-000-JSS-1543-001 to be considered.
- 7.(I) S.No 12: Valve shall be Eccentric/Rotary Plug Type fully Jacketed valve with end connection as follows:
  - (a) Valve end flange Bolt Centre Dia :- 12 inch, 300#.
  - (b) Valve Process Dia of 10 inch.
- (II) For steam jacketing, valve will have 3/4" 300# steam in and steam out connection. Valve is jacketed using LP steam. LP Steam conditions are as follows:  
Pressure (Operating / Design) Kg/cm2g:- 4 /7 kg/cm2g  
Temperature (Operating / Design) Kg/cm2g:- 175 / 240 °C
8. Trim Material shall be as per API Trim No 8
9. Valve Design shall be inherently Fire Safe.

				INSTRUMENT SPECIFICATION ON OFF VALVE	 		
1	AK	07-08-2021	Re-issued with MR				
0	AK	22-06-2021	Issued with MR				
No.	By	Date	Revision	Code:73	Dwg. No.: B366-088-YC-DS-3218	Sheet 2 of 2	Rev.: 1

GENERAL	1	Tag No.	088-XZV -0211																																																																																																																																														
	2	Service	SULFUR VAPOR INLET ON-OFF VALVE																																																																																																																																														
	3	Line No.	8"-P-088-3220-A15A-IJ																																																																																																																																														
	4	Area Classification	Zone-1 Gr. IIA & IIB, T3																																																																																																																																														
	5	Ambient Temperature:	Min.	Max.	°C °C																																																																																																																																												
	6	Allowable Sound Pressure Level	dBA																																																																																																																																														
	7	Control Action- On-Off (or) Modulating	On Off																																																																																																																																														
	8	Available Air Supply Pressure:	Min.	Max.	kgf/cm <sup>2</sup> -g kgf/cm <sup>2</sup> -g																																																																																																																																												
	9	Failure Position	Close																																																																																																																																														
PIPE LINE	10																																																																																																																																																
	11	Line Size and Schedule	8 in STD																																																																																																																																														
PROCESS CONDITIONS	12	Inlet Line ID (inch)	Outlet Line ID (inch)																																																																																																																																														
	13																																																																																																																																																
	14	Process Fluid	Fluid State	Fluid Phase																																																																																																																																													
	15	% Flash	% Solids																																																																																																																																														
	16	Differential Pressure-Shut Off	7 bar																																																																																																																																														
	17		Units	@ Max. Flow	@ Norm. Flow																																																																																																																																												
	18	Flow Rate	@ Min. Flow																																																																																																																																														
	19	Inlet Pressure	kgf/cm <sup>2</sup> -g																																																																																																																																														
	20	Pressure Drop	bar																																																																																																																																														
	21	Inlet Temperature	°C																																																																																																																																														
	22	Inlet Density / Specific Gravity / Molecular Mass	kg/m <sup>3</sup>																																																																																																																																														
	23	Inlet Compressibility Factor	-																																																																																																																																														
	24	Inlet Viscosity	cP																																																																																																																																														
	25	Inlet Specific Heat Ratio	-																																																																																																																																														
	26	Inlet Vapour Pressure																																																																																																																																															
	27	Critical Pressure																																																																																																																																															
	CALCULATED RESULTS	28	Flow Coefficient Cv	Max.	Nor	Min.																																																																																																																																											
29		Travel	Inlet Velocity																																																																																																																																														
RESULTS	30	Sound Pressure Level	dBA																																																																																																																																														
	31	MFR	Model	*	*																																																																																																																																												
BODY AND TRIM	32	Body Type	Eccentric / Rotary Plug																																																																																																																																														
	33	Body Size	Port Size	8 in FULL																																																																																																																																													
	34	Rated Cv	Characteris.	*																																																																																																																																													
	35	End Connec. & Rating	10" x 8", 300#																																																																																																																																														
	36	Facing and Finish	RF 125AARH																																																																																																																																														
	37	Body, Bonnet Material	ASTM A216 Gr WCB																																																																																																																																														
	38	Packing Material	Graphite																																																																																																																																														
	39	Rated Travel	MFR STD																																																																																																																																														
	40	Lubricator	Isolat. Valve																																																																																																																																														
	41	Guiding	No. of Ports																																																																																																																																														
	42	Trim Type																																																																																																																																															
	43	Trim Material	SS 316																																																																																																																																														
	44	Other Wetted Parts Material	*																																																																																																																																														
	45	Soft Seat	Material	Metal Seat	*																																																																																																																																												
	46																																																																																																																																																
	ACTUATOR	47	Gasket Material	Spiral Wound Gasket SS316																																																																																																																																													
48		Bonnet Type	Mfr Std																																																																																																																																														
49		MFR	Model	*	*																																																																																																																																												
50		Type	Pneumatic Piston Actuator																																																																																																																																														
51		Size	Area																																																																																																																																														
52		Air Failure Valve:																																																																																																																																															
53		Handwheel Location	NO																																																																																																																																														
54		Bench Range																																																																																																																																															
55		Spring Action	FAIL CLOSE																																																																																																																																														
Notes:																																																																																																																																																	
<table border="1"> <tr> <td>56</td> <td>MFR</td> <td>Model</td> <td>*</td> <td>*</td> </tr> <tr> <td>57</td> <td>Signal: Inlet</td> <td>Outlet</td> <td colspan="2">4-20mA</td> </tr> <tr> <td>58</td> <td>Type</td> <td colspan="3">SMART, HART</td> </tr> <tr> <td>59</td> <td>Air Supply Pressure</td> <td colspan="3">3.5 kg/cm<sup>2</sup>-g</td> </tr> <tr> <td>60</td> <td>Bypass</td> <td>Gauges</td> <td>No</td> <td>2 No's</td> </tr> <tr> <td>61</td> <td>I/P Converter</td> <td colspan="3"></td> </tr> <tr> <td>62</td> <td>Silencer Exp Baffle Plate</td> <td colspan="3"></td> </tr> <tr> <td>63</td> <td>Pneu. Lock Relay/Vol. Bos</td> <td colspan="3"></td> </tr> <tr> <td>64</td> <td>Type</td> <td colspan="3">3 WAY Universal</td> </tr> <tr> <td>65</td> <td>When De-Enegr.Valve:</td> <td colspan="3"></td> </tr> <tr> <td>66</td> <td>Tag No.</td> <td colspan="3">088-XZY-0211</td> </tr> <tr> <td>67</td> <td>MFR</td> <td>Model</td> <td>*</td> <td>*</td> </tr> <tr> <td>68</td> <td>Type</td> <td>Quantity</td> <td>Proximity</td> <td>2 no's.</td> </tr> <tr> <td>69</td> <td>Voltage</td> <td colspan="3">24V DC</td> </tr> <tr> <td>70</td> <td>Switching Position</td> <td colspan="3">FULL OPEN/ FULL CLOSE</td> </tr> <tr> <td>71</td> <td>Tag No.</td> <td colspan="3">088-ZSL/ ZSH-0211</td> </tr> <tr> <td>72</td> <td>MFR</td> <td>Model</td> <td>*</td> <td>*</td> </tr> <tr> <td>73</td> <td>Set Pressure</td> <td colspan="3"></td> </tr> <tr> <td>74</td> <td>Filter</td> <td>Gauge</td> <td>Required</td> <td>Yes, 1 no.</td> </tr> <tr> <td>75</td> <td>MFR</td> <td>Model</td> <td>*</td> <td>*</td> </tr> <tr> <td>76</td> <td>Leakage Class</td> <td colspan="3">CLASS V , TSO</td> </tr> <tr> <td>77</td> <td>IBR</td> <td>Hydrogen</td> <td>YES</td> <td></td> </tr> <tr> <td>78</td> <td>Req. Number</td> <td colspan="3"></td> </tr> <tr> <td>79</td> <td>Manufacturer</td> <td colspan="3">*</td> </tr> <tr> <td>80</td> <td>Model</td> <td colspan="3">*</td> </tr> <tr> <td>81</td> <td>Purchase Order Num.</td> <td colspan="3">B366-999-YC-MR-2451</td> </tr> <tr> <td>82</td> <td>Price</td> <td>Item Number</td> <td colspan="2"></td> </tr> <tr> <td>83</td> <td>Serial Number</td> <td colspan="3"></td> </tr> </table>						56	MFR	Model	*	*	57	Signal: Inlet	Outlet	4-20mA		58	Type	SMART, HART			59	Air Supply Pressure	3.5 kg/cm <sup>2</sup> -g			60	Bypass	Gauges	No	2 No's	61	I/P Converter				62	Silencer Exp Baffle Plate				63	Pneu. Lock Relay/Vol. Bos				64	Type	3 WAY Universal			65	When De-Enegr.Valve:				66	Tag No.	088-XZY-0211			67	MFR	Model	*	*	68	Type	Quantity	Proximity	2 no's.	69	Voltage	24V DC			70	Switching Position	FULL OPEN/ FULL CLOSE			71	Tag No.	088-ZSL/ ZSH-0211			72	MFR	Model	*	*	73	Set Pressure				74	Filter	Gauge	Required	Yes, 1 no.	75	MFR	Model	*	*	76	Leakage Class	CLASS V , TSO			77	IBR	Hydrogen	YES		78	Req. Number				79	Manufacturer	*			80	Model	*			81	Purchase Order Num.	B366-999-YC-MR-2451			82	Price	Item Number			83	Serial Number			
56	MFR	Model	*	*																																																																																																																																													
57	Signal: Inlet	Outlet	4-20mA																																																																																																																																														
58	Type	SMART, HART																																																																																																																																															
59	Air Supply Pressure	3.5 kg/cm <sup>2</sup> -g																																																																																																																																															
60	Bypass	Gauges	No	2 No's																																																																																																																																													
61	I/P Converter																																																																																																																																																
62	Silencer Exp Baffle Plate																																																																																																																																																
63	Pneu. Lock Relay/Vol. Bos																																																																																																																																																
64	Type	3 WAY Universal																																																																																																																																															
65	When De-Enegr.Valve:																																																																																																																																																
66	Tag No.	088-XZY-0211																																																																																																																																															
67	MFR	Model	*	*																																																																																																																																													
68	Type	Quantity	Proximity	2 no's.																																																																																																																																													
69	Voltage	24V DC																																																																																																																																															
70	Switching Position	FULL OPEN/ FULL CLOSE																																																																																																																																															
71	Tag No.	088-ZSL/ ZSH-0211																																																																																																																																															
72	MFR	Model	*	*																																																																																																																																													
73	Set Pressure																																																																																																																																																
74	Filter	Gauge	Required	Yes, 1 no.																																																																																																																																													
75	MFR	Model	*	*																																																																																																																																													
76	Leakage Class	CLASS V , TSO																																																																																																																																															
77	IBR	Hydrogen	YES																																																																																																																																														
78	Req. Number																																																																																																																																																
79	Manufacturer	*																																																																																																																																															
80	Model	*																																																																																																																																															
81	Purchase Order Num.	B366-999-YC-MR-2451																																																																																																																																															
82	Price	Item Number																																																																																																																																															
83	Serial Number																																																																																																																																																
<table border="1"> <tr> <td colspan="4">INSTRUMENT SPECIFICATION</td> <td rowspan="2">   </td> </tr> <tr> <td colspan="4">ON OFF VALVE</td> </tr> <tr> <td colspan="4">Project: BHEL IOCL PARADIP</td> </tr> <tr> <td colspan="4">Job No : B366</td> </tr> <tr> <td colspan="4">Unit No.:088- SRU 3</td> </tr> <tr> <td colspan="4">Sheet 1 of 2</td> </tr> </table>						INSTRUMENT SPECIFICATION				 	ON OFF VALVE				Project: BHEL IOCL PARADIP				Job No : B366				Unit No.:088- SRU 3				Sheet 1 of 2																																																																																																																						
INSTRUMENT SPECIFICATION				 																																																																																																																																													
ON OFF VALVE																																																																																																																																																	
Project: BHEL IOCL PARADIP																																																																																																																																																	
Job No : B366																																																																																																																																																	
Unit No.:088- SRU 3																																																																																																																																																	
Sheet 1 of 2																																																																																																																																																	
No.	By	Date	Revision	Code: 73	Doc. No.: B366-088-YC-DS-3219	Rev.: 1																																																																																																																																											



1. " \* " indicates data to be furnished by Vendor.
2. Partial Stroke testing (PST) device is required as per specifications mentioned in 080557C-000-JSS-1543-001.  
Tag No. shall be 088-PST-0211.
3. Bolting Material shall be ASTM A193 Gr. B7 for Bolts & A194 Gr. 2H for Studs Nuts.
4. Design Conditions:  
Design Pressure (Max/) : 7 kg/cm<sup>2</sup>  
Design Temperature (Max): 240°C
5. Valve closing time : Within 8 sec
6. IBR requirement as per CI No. 10.10 of Doc. No. 080557C-000-JSS-1543-001 to be considered.
- 7.(I) S.No 12: Valve shall be Eccentric/Rotary Plug Type fully Jacketed valve with end connection as follows:
  - (a) Valve end flange Bolt Centre Dia :- 10inch, 300#.
  - (b) Valve Process Dia of 8inch.
- (II) For steam jacketing, valve will have 3/4" 300# steam in and steam out connection. Valve is jacketed using LP steam. LP Steam conditions are as follows:  
Pressure (Operating / Design) Kg/cm<sup>2</sup>:- 4 / 7 kg/cm<sup>2</sup>  
Temperature (Operating / Design) Kg/cm<sup>2</sup>:- 175 / 240 °C
8. Trim Material shall be as per API Trim No 8.
9. Valve Design shall be inherently Fire Safe.

				INSTRUMENT SPECIFICATION ON OFF VALVE	 
1	AK	07-08-2021	Re-issued with MR		
0	AK	22-06-2021	Issued with MR		
No.	By	Date	Revision	Code:73	Dwg. No.: B366-088-YC-DS-3219
				Sheet 2	of 2
				Rev.: 1	

GENERAL	1	Tag No.	088-XZV -0221																																																																																																																																													
	2	Service	DEGASSED SULFUR TO SULFUR STORAGE																																																																																																																																													
	3	Line No.	6"-P-088-3326-A15A-IJ																																																																																																																																													
	4	Area Classification	Zone-1 Gr. IIA & IIB, T3																																																																																																																																													
	5	Ambient Temperature:	Min.	Max.	°C °C																																																																																																																																											
	6	Allowable Sound Pressure Level	dBA																																																																																																																																													
	7	Control Action- On-Off (or) Modulating	On Off																																																																																																																																													
	8	Available Air Supply Pressure:	Min.	Max.	kgf/cm <sup>2</sup> -g kgf/cm <sup>2</sup> -g																																																																																																																																											
	9	Failure Position	Close																																																																																																																																													
PIPE LINE	10																																																																																																																																															
	11	Line Size and Schedule	6 in STD																																																																																																																																													
PROCESS CONDITIONS	12	Inlet Line ID (inch)	Outlet Line ID (inch)																																																																																																																																													
	13																																																																																																																																															
	14	Process Fluid	Fluid State	Fluid Phase																																																																																																																																												
	15	% Flash	% Solids																																																																																																																																													
	16	Differential Pressure-Shut Off	8.6 kgf/cm <sup>2</sup>																																																																																																																																													
	17		Units	@ Max. Flow	@ Norm. Flow																																																																																																																																											
	18	Flow Rate	@ Min. Flow																																																																																																																																													
	19	Inlet Pressure	kgf/cm <sup>2</sup> -g																																																																																																																																													
	20	Pressure Drop	bar																																																																																																																																													
	21	Inlet Temperature	°C																																																																																																																																													
	22	Inlet Density / Specific Gravity / Molecular Mass	kg/m <sup>3</sup>																																																																																																																																													
	23	Inlet Compressibility Factor	-																																																																																																																																													
	24	Inlet Viscosity	cP																																																																																																																																													
	25	Inlet Specific Heat Ratio	-																																																																																																																																													
	26	Inlet Vapour Pressure																																																																																																																																														
	27	Critical Pressure																																																																																																																																														
	CALCULATED RESULTS	28	Flow Coefficient Cv	Max.	Nor	Min.																																																																																																																																										
29		Travel	Inlet Velocity																																																																																																																																													
BODY AND TRIM	30	Sound Pressure Level	dBA																																																																																																																																													
	31	MFR	Model	*	*																																																																																																																																											
	32	Body Type	Eccentric / Rotary Plug																																																																																																																																													
	33	Body Size	Port Size	6 in	FULL																																																																																																																																											
	34	Rated Cv	Characteris.	*																																																																																																																																												
	35	End Connec. & Rating	8" x 6" , 300#																																																																																																																																													
	36	Facing and Finish	RF 125AARH																																																																																																																																													
	37	Body,Bonnet Material	ASTM A216 Gr WCB																																																																																																																																													
	38	Packing Material	Graphite																																																																																																																																													
	39	Rated Travel	MFR STD																																																																																																																																													
	40	Lubricator	Isolat. Valve																																																																																																																																													
	41	Guiding	No. of Ports																																																																																																																																													
	42	Trim Type																																																																																																																																														
	43	Trim Material	SS 316																																																																																																																																													
	44	Other Wetted Parts Material	Mfr Std																																																																																																																																													
	ACTUATOR	45	Soft Seat	Material	Metal Seat	*																																																																																																																																										
		46																																																																																																																																														
47		Gasket Material	Spiral Wound Gasket SS316																																																																																																																																													
48		Bonnet Type	Mfr Std																																																																																																																																													
49		MFR	Model	*	*																																																																																																																																											
50		Type	Pneumatic Piston Actuator																																																																																																																																													
51		Size	Area																																																																																																																																													
52		Air Failure Valve:																																																																																																																																														
53		Handwheel Location	NO																																																																																																																																													
54		Bench Range																																																																																																																																														
55		Spring Action	FAIL CLOSE																																																																																																																																													
Notes:																																																																																																																																																
<table border="1"> <tr> <td>56</td> <td>MFR</td> <td>Model</td> <td>*</td> <td>*</td> </tr> <tr> <td>57</td> <td>Signal: Inlet</td> <td>Outlet</td> <td colspan="2">4-20mA</td> </tr> <tr> <td>58</td> <td>Type</td> <td colspan="3">SMART, HART</td> </tr> <tr> <td>59</td> <td>Air Supply Pressure</td> <td colspan="3">3.5 kg/cm<sup>2</sup>-g</td> </tr> <tr> <td>60</td> <td>Bypass</td> <td>Gauges</td> <td>No</td> <td>2 No's</td> </tr> <tr> <td>61</td> <td>I/P Converter</td> <td colspan="3"></td> </tr> <tr> <td>62</td> <td>Silencer Exp Baffle Plate</td> <td colspan="3"></td> </tr> <tr> <td>63</td> <td>Pneu. Lock Relay/Vol. Bos</td> <td colspan="3"></td> </tr> <tr> <td>64</td> <td>Type</td> <td colspan="3">3 WAY Universal</td> </tr> <tr> <td>65</td> <td>When De-Enegr.Valve:</td> <td colspan="3"></td> </tr> <tr> <td>66</td> <td>Tag No.</td> <td colspan="3">088-XZY-0221</td> </tr> <tr> <td>67</td> <td>MFR</td> <td>Model</td> <td>*</td> <td>*</td> </tr> <tr> <td>68</td> <td>Type</td> <td>Quantity</td> <td>Proximity</td> <td>2 no's.</td> </tr> <tr> <td>69</td> <td>Voltage</td> <td colspan="3">24V DC</td> </tr> <tr> <td>70</td> <td>Switching Position</td> <td colspan="3">FULL OPEN/ FULL CLOSE</td> </tr> <tr> <td>71</td> <td>Tag No.</td> <td colspan="3">088-ZSL/ ZSH-0221</td> </tr> <tr> <td>72</td> <td>MFR</td> <td>Model</td> <td>*</td> <td>*</td> </tr> <tr> <td>73</td> <td>Set Pressure</td> <td colspan="3"></td> </tr> <tr> <td>74</td> <td>Filter</td> <td>Gauge</td> <td>Required</td> <td>Yes, 1 no.</td> </tr> <tr> <td>75</td> <td>MFR</td> <td>Model</td> <td>*</td> <td>*</td> </tr> <tr> <td>76</td> <td>Leakage Class</td> <td colspan="3">CLASS IV</td> </tr> <tr> <td>77</td> <td>IBR</td> <td>Hydrogen</td> <td>YES</td> <td></td> </tr> <tr> <td>78</td> <td>Req. Number</td> <td colspan="3"></td> </tr> <tr> <td>79</td> <td>Manufacturer</td> <td colspan="3">*</td> </tr> <tr> <td>80</td> <td>Model</td> <td colspan="3">*</td> </tr> <tr> <td>81</td> <td>Purchase Order Num.</td> <td colspan="3">B366-999-YC-MR-2451</td> </tr> <tr> <td>82</td> <td>Price</td> <td>Item Number</td> <td colspan="2"></td> </tr> <tr> <td>83</td> <td>Serial Number</td> <td colspan="3"></td> </tr> </table>					56	MFR	Model	*	*	57	Signal: Inlet	Outlet	4-20mA		58	Type	SMART, HART			59	Air Supply Pressure	3.5 kg/cm <sup>2</sup> -g			60	Bypass	Gauges	No	2 No's	61	I/P Converter				62	Silencer Exp Baffle Plate				63	Pneu. Lock Relay/Vol. Bos				64	Type	3 WAY Universal			65	When De-Enegr.Valve:				66	Tag No.	088-XZY-0221			67	MFR	Model	*	*	68	Type	Quantity	Proximity	2 no's.	69	Voltage	24V DC			70	Switching Position	FULL OPEN/ FULL CLOSE			71	Tag No.	088-ZSL/ ZSH-0221			72	MFR	Model	*	*	73	Set Pressure				74	Filter	Gauge	Required	Yes, 1 no.	75	MFR	Model	*	*	76	Leakage Class	CLASS IV			77	IBR	Hydrogen	YES		78	Req. Number				79	Manufacturer	*			80	Model	*			81	Purchase Order Num.	B366-999-YC-MR-2451			82	Price	Item Number			83	Serial Number			
56	MFR	Model	*	*																																																																																																																																												
57	Signal: Inlet	Outlet	4-20mA																																																																																																																																													
58	Type	SMART, HART																																																																																																																																														
59	Air Supply Pressure	3.5 kg/cm <sup>2</sup> -g																																																																																																																																														
60	Bypass	Gauges	No	2 No's																																																																																																																																												
61	I/P Converter																																																																																																																																															
62	Silencer Exp Baffle Plate																																																																																																																																															
63	Pneu. Lock Relay/Vol. Bos																																																																																																																																															
64	Type	3 WAY Universal																																																																																																																																														
65	When De-Enegr.Valve:																																																																																																																																															
66	Tag No.	088-XZY-0221																																																																																																																																														
67	MFR	Model	*	*																																																																																																																																												
68	Type	Quantity	Proximity	2 no's.																																																																																																																																												
69	Voltage	24V DC																																																																																																																																														
70	Switching Position	FULL OPEN/ FULL CLOSE																																																																																																																																														
71	Tag No.	088-ZSL/ ZSH-0221																																																																																																																																														
72	MFR	Model	*	*																																																																																																																																												
73	Set Pressure																																																																																																																																															
74	Filter	Gauge	Required	Yes, 1 no.																																																																																																																																												
75	MFR	Model	*	*																																																																																																																																												
76	Leakage Class	CLASS IV																																																																																																																																														
77	IBR	Hydrogen	YES																																																																																																																																													
78	Req. Number																																																																																																																																															
79	Manufacturer	*																																																																																																																																														
80	Model	*																																																																																																																																														
81	Purchase Order Num.	B366-999-YC-MR-2451																																																																																																																																														
82	Price	Item Number																																																																																																																																														
83	Serial Number																																																																																																																																															
<table border="1"> <tr> <td colspan="4">INSTRUMENT SPECIFICATION</td> </tr> <tr> <td colspan="4">ON OFF VALVE</td> </tr> <tr> <td colspan="4">Project: BHEL IOCL PARADIP</td> </tr> <tr> <td colspan="4">Job No : B366</td> </tr> <tr> <td colspan="4">Unit No.:088- SRU 3</td> </tr> <tr> <td colspan="2">Code: 73</td> <td colspan="2">Doc. No.: B366-088-YC-DS-3221</td> </tr> <tr> <td colspan="2">Rev.: 1</td> <td colspan="2">Sheet 1 of 2</td> </tr> </table>					INSTRUMENT SPECIFICATION				ON OFF VALVE				Project: BHEL IOCL PARADIP				Job No : B366				Unit No.:088- SRU 3				Code: 73		Doc. No.: B366-088-YC-DS-3221		Rev.: 1		Sheet 1 of 2																																																																																																																	
INSTRUMENT SPECIFICATION																																																																																																																																																
ON OFF VALVE																																																																																																																																																
Project: BHEL IOCL PARADIP																																																																																																																																																
Job No : B366																																																																																																																																																
Unit No.:088- SRU 3																																																																																																																																																
Code: 73		Doc. No.: B366-088-YC-DS-3221																																																																																																																																														
Rev.: 1		Sheet 1 of 2																																																																																																																																														
<table border="1"> <tr> <td>1</td> <td>AK</td> <td>07-08-2021</td> <td colspan="2">Re-issued with MR</td> </tr> <tr> <td>0</td> <td>AK</td> <td>22-06-2021</td> <td colspan="2">Issued with MR</td> </tr> <tr> <td>No.</td> <td>By</td> <td>Date</td> <td colspan="2">Revision</td> </tr> </table>					1	AK	07-08-2021	Re-issued with MR		0	AK	22-06-2021	Issued with MR		No.	By	Date	Revision																																																																																																																														
1	AK	07-08-2021	Re-issued with MR																																																																																																																																													
0	AK	22-06-2021	Issued with MR																																																																																																																																													
No.	By	Date	Revision																																																																																																																																													





1. " \* " indicates data to be furnished by Vendor.
2. Partial Stroke testing (PST) device is required as per specifications mentioned in 080557C-000-JSS-1543-001.  
Tag No. shall be 088-PST-0221.
3. Bolting Material shall be ASTM A193 Gr. B7 for Bolts & A194 Gr. 2H for Studs Nuts.
4. Design Conditions:  
Design Pressure (Max/) : 8.6 kg/cm2g  
Design Temperature (Max): 200°C
5. Valve closing time : Within 6 sec
6. Trim Material shall be as per API Trim No 8.
7. IBR requirement as per CI No. 10.10 of Doc. No. 080557C-000-JSS-1543-001 to be considered.
- 8.(I) S.No 12: Valve shall be Eccentric/Rotary Plug Type fully Jacketed valve with end connection as follows:
  - (a) Valve end flange Bolt Centre Dia :- 8 inch, 300#.
  - (b) Valve Process Dia of 6 inch.
- (II) For steam jacketing, valve will have 3/4" 300# steam in and steam out connection. Valve is jacketed using LP steam. LP Steam conditions are as follows:  
Pressure (Operating / Design) Kg/cm2g:- 4 /7 kg/cm2g  
Temperature (Operating / Design) Kg/cm2g:- 175 / 240 °C
9. Valve Design shall be inherently Fire Safe.

				INSTRUMENT SPECIFICATION		 		
				ON OFF VALVE				
1	AK	07-08-2021	Re-issued with MR			Sheet 2	of 2	
0	AK	22-06-2021	Issued with MR					
No.	By	Date	Revision	Code:73	Dwg. No.:	B366-088-YC-DS-3221		Rev.: 1

GENERAL	1	Tag No.	088-XZV -0222																																																																																																																																													
	2	Service	DEGASSING OVERHEAD TO INCINERATOR																																																																																																																																													
	3	Line No.	6"-P-088-3403-A15A-IJ																																																																																																																																													
	4	Area Classification	Zone-1 Gr. IIA & IIB, T3																																																																																																																																													
	5	Ambient Temperature:	Min.	Max.	°C °C																																																																																																																																											
	6	Allowable Sound Pressure Level	dBA																																																																																																																																													
	7	Control Action- On-Off (or) Modulating	On Off																																																																																																																																													
	8	Available Air Supply Pressure:	Min.	Max.	kgf/cm <sup>2</sup> -g kgf/cm <sup>2</sup> -g																																																																																																																																											
	9	Failure Position	Close																																																																																																																																													
PIPE LINE	10																																																																																																																																															
	11	Line Size and Schedule	6 in STD																																																																																																																																													
PROCESS CONDITIONS	12	Inlet Line ID (inch)	Outlet Line ID (inch)																																																																																																																																													
	13																																																																																																																																															
	14	Process Fluid	Fluid State	Fluid Phase																																																																																																																																												
	15	% Flash	% Solids																																																																																																																																													
	16	Differential Pressure-Shut Off	7 kgf/cm <sup>2</sup>																																																																																																																																													
	17		Units	@ Max. Flow	@ Norm. Flow																																																																																																																																											
	18	Flow Rate	@ Min. Flow																																																																																																																																													
	19	Inlet Pressure	kgf/cm <sup>2</sup> -g																																																																																																																																													
	20	Pressure Drop	bar																																																																																																																																													
	21	Inlet Temperature	°C																																																																																																																																													
	22	Inlet Density / Specific Gravity / Molecular Mass	kg/m <sup>3</sup>																																																																																																																																													
	23	Inlet Compressibility Factor	-																																																																																																																																													
	24	Inlet Viscosity	cP																																																																																																																																													
	25	Inlet Specific Heat Ratio	-																																																																																																																																													
	26	Inlet Vapour Pressure																																																																																																																																														
	27	Critical Pressure																																																																																																																																														
	CALCULATED RESULTS	28	Flow Coefficient Cv	Max.	Nor	Min.																																																																																																																																										
29		Travel	Inlet Velocity																																																																																																																																													
BODY AND TRIM	30	Sound Pressure Level	dBA																																																																																																																																													
	31	MFR	Model	*	*																																																																																																																																											
	32	Body Type	Eccentric / Rotary Plug																																																																																																																																													
	33	Body Size	Port Size	6 in	FULL																																																																																																																																											
	34	Rated Cv	Characteris.	*																																																																																																																																												
	35	End Connec. & Rating	8" x 6" , 300#																																																																																																																																													
	36	Facing and Finish	RF 125AARH																																																																																																																																													
	37	Body,Bonnet Material	ASTM A216 Gr WCB																																																																																																																																													
	38	Packing Material	Graphite																																																																																																																																													
	39	Rated Travel	MFR STD																																																																																																																																													
	40	Lubricator	Isolat. Valve																																																																																																																																													
	41	Guiding	No. of Ports																																																																																																																																													
	42	Trim Type																																																																																																																																														
	43	Trim Material	SS 316																																																																																																																																													
	44	Other Wetted Parts Material	*																																																																																																																																													
	ACTUATOR	45	Soft Seat	Material	Metal Seat	*																																																																																																																																										
		46																																																																																																																																														
47		Gasket Material	Spiral Wound Gasket SS316																																																																																																																																													
48		Bonnet Type	Mfr Std																																																																																																																																													
49		MFR	Model	*	*																																																																																																																																											
50		Type	Pneumatic Piston Actuator																																																																																																																																													
51		Size	Area																																																																																																																																													
52		Air Failure Valve:																																																																																																																																														
53		Handwheel Location	NO																																																																																																																																													
54		Bench Range																																																																																																																																														
55	Spring Action	FAIL CLOSE																																																																																																																																														
Notes:																																																																																																																																																
<table border="1"> <tr> <td>56</td> <td>MFR</td> <td>Model</td> <td>*</td> <td>*</td> </tr> <tr> <td>57</td> <td>Signal: Inlet</td> <td>Outlet</td> <td colspan="2">4-20mA</td> </tr> <tr> <td>58</td> <td>Type</td> <td colspan="3">SMART, HART</td> </tr> <tr> <td>59</td> <td>Air Supply Pressure</td> <td colspan="3">3.5 kg/cm<sup>2</sup>-g</td> </tr> <tr> <td>60</td> <td>Bypass</td> <td>Gauges</td> <td>No</td> <td>2 No's</td> </tr> <tr> <td>61</td> <td>I/P Converter</td> <td colspan="3"></td> </tr> <tr> <td>62</td> <td>Silencer Exp Baffle Plate</td> <td colspan="3"></td> </tr> <tr> <td>63</td> <td>Pneu. Lock Relay/Vol. Bos</td> <td colspan="3"></td> </tr> <tr> <td>64</td> <td>Type</td> <td colspan="3">3 WAY Universal</td> </tr> <tr> <td>65</td> <td>When De-Enegr.Valve:</td> <td colspan="3"></td> </tr> <tr> <td>66</td> <td>Tag No.</td> <td colspan="3">088-XZY-0222</td> </tr> <tr> <td>67</td> <td>MFR</td> <td>Model</td> <td>*</td> <td>*</td> </tr> <tr> <td>68</td> <td>Type</td> <td>Quantity</td> <td>Proximity</td> <td>2 no's.</td> </tr> <tr> <td>69</td> <td>Voltage</td> <td colspan="3">24V DC</td> </tr> <tr> <td>70</td> <td>Switching Position</td> <td colspan="3">FULL OPEN/ FULL CLOSE</td> </tr> <tr> <td>71</td> <td>Tag No.</td> <td colspan="3">088-ZSL/ ZSH-0222</td> </tr> <tr> <td>72</td> <td>MFR</td> <td>Model</td> <td>*</td> <td>*</td> </tr> <tr> <td>73</td> <td>Set Pressure</td> <td colspan="3"></td> </tr> <tr> <td>74</td> <td>Filter</td> <td>Gauge</td> <td>Required</td> <td>Yes, 1 no.</td> </tr> <tr> <td>75</td> <td>MFR</td> <td>Model</td> <td>*</td> <td>*</td> </tr> <tr> <td>76</td> <td>Leakage Class</td> <td colspan="3">CLASS V , TSO</td> </tr> <tr> <td>77</td> <td>IBR</td> <td>Hydrogen</td> <td>YES</td> <td></td> </tr> <tr> <td>78</td> <td>Req. Number</td> <td colspan="3"></td> </tr> <tr> <td>79</td> <td>Manufacturer</td> <td colspan="3">*</td> </tr> <tr> <td>80</td> <td>Model</td> <td colspan="3">*</td> </tr> <tr> <td>81</td> <td>Purchase Order Num.</td> <td colspan="3">B366-999-YC-MR-2451</td> </tr> <tr> <td>82</td> <td>Price</td> <td>Item Number</td> <td colspan="2"></td> </tr> <tr> <td>83</td> <td>Serial Number</td> <td colspan="3"></td> </tr> </table>					56	MFR	Model	*	*	57	Signal: Inlet	Outlet	4-20mA		58	Type	SMART, HART			59	Air Supply Pressure	3.5 kg/cm <sup>2</sup> -g			60	Bypass	Gauges	No	2 No's	61	I/P Converter				62	Silencer Exp Baffle Plate				63	Pneu. Lock Relay/Vol. Bos				64	Type	3 WAY Universal			65	When De-Enegr.Valve:				66	Tag No.	088-XZY-0222			67	MFR	Model	*	*	68	Type	Quantity	Proximity	2 no's.	69	Voltage	24V DC			70	Switching Position	FULL OPEN/ FULL CLOSE			71	Tag No.	088-ZSL/ ZSH-0222			72	MFR	Model	*	*	73	Set Pressure				74	Filter	Gauge	Required	Yes, 1 no.	75	MFR	Model	*	*	76	Leakage Class	CLASS V , TSO			77	IBR	Hydrogen	YES		78	Req. Number				79	Manufacturer	*			80	Model	*			81	Purchase Order Num.	B366-999-YC-MR-2451			82	Price	Item Number			83	Serial Number			
56	MFR	Model	*	*																																																																																																																																												
57	Signal: Inlet	Outlet	4-20mA																																																																																																																																													
58	Type	SMART, HART																																																																																																																																														
59	Air Supply Pressure	3.5 kg/cm <sup>2</sup> -g																																																																																																																																														
60	Bypass	Gauges	No	2 No's																																																																																																																																												
61	I/P Converter																																																																																																																																															
62	Silencer Exp Baffle Plate																																																																																																																																															
63	Pneu. Lock Relay/Vol. Bos																																																																																																																																															
64	Type	3 WAY Universal																																																																																																																																														
65	When De-Enegr.Valve:																																																																																																																																															
66	Tag No.	088-XZY-0222																																																																																																																																														
67	MFR	Model	*	*																																																																																																																																												
68	Type	Quantity	Proximity	2 no's.																																																																																																																																												
69	Voltage	24V DC																																																																																																																																														
70	Switching Position	FULL OPEN/ FULL CLOSE																																																																																																																																														
71	Tag No.	088-ZSL/ ZSH-0222																																																																																																																																														
72	MFR	Model	*	*																																																																																																																																												
73	Set Pressure																																																																																																																																															
74	Filter	Gauge	Required	Yes, 1 no.																																																																																																																																												
75	MFR	Model	*	*																																																																																																																																												
76	Leakage Class	CLASS V , TSO																																																																																																																																														
77	IBR	Hydrogen	YES																																																																																																																																													
78	Req. Number																																																																																																																																															
79	Manufacturer	*																																																																																																																																														
80	Model	*																																																																																																																																														
81	Purchase Order Num.	B366-999-YC-MR-2451																																																																																																																																														
82	Price	Item Number																																																																																																																																														
83	Serial Number																																																																																																																																															
<table border="1"> <tr> <td colspan="4">INSTRUMENT SPECIFICATION</td> </tr> <tr> <td colspan="4">ON OFF VALVE</td> </tr> <tr> <td colspan="4">Project: BHEL IOCL PARADIP</td> </tr> <tr> <td colspan="4">Job No : B366</td> </tr> <tr> <td colspan="4">Unit No.:088- SRU 3</td> </tr> <tr> <td colspan="2">Sheet 1</td> <td colspan="2">of 2</td> </tr> </table>					INSTRUMENT SPECIFICATION				ON OFF VALVE				Project: BHEL IOCL PARADIP				Job No : B366				Unit No.:088- SRU 3				Sheet 1		of 2																																																																																																																					
INSTRUMENT SPECIFICATION																																																																																																																																																
ON OFF VALVE																																																																																																																																																
Project: BHEL IOCL PARADIP																																																																																																																																																
Job No : B366																																																																																																																																																
Unit No.:088- SRU 3																																																																																																																																																
Sheet 1		of 2																																																																																																																																														
<table border="1"> <tr> <td>1</td> <td>AK</td> <td>07-08-2021</td> <td colspan="2">Re-issued with MR</td> </tr> <tr> <td>0</td> <td>AK</td> <td>22-06-2021</td> <td colspan="2">Issued with MR</td> </tr> <tr> <td>No.</td> <td>By</td> <td>Date</td> <td colspan="2">Revision</td> </tr> </table>					1	AK	07-08-2021	Re-issued with MR		0	AK	22-06-2021	Issued with MR		No.	By	Date	Revision																																																																																																																														
1	AK	07-08-2021	Re-issued with MR																																																																																																																																													
0	AK	22-06-2021	Issued with MR																																																																																																																																													
No.	By	Date	Revision																																																																																																																																													
Code: 73		Doc. No.: B366-088-YC-DS-3222		Rev.: 1																																																																																																																																												



1. " \* " indicates data to be furnished by Vendor.
2. Partial Stroke testing (PST) device is required as per specifications mentioned in 080557C-000-JSS-1543-001. Tag No. shall be 088-PST-0222.
3. Bolting Material shall be ASTM A193 Gr. B7 for Bolts & A194 Gr. 2H for Studs Nuts.
4. Design Conditions:
  - Design Pressure (Max/) : 7 kg/cm2g
  - Design Temperature (Max): 200°C
5. Valve closing time : Within 6 sec
6. IBR requirement as per CI No. 10.10 of Doc. No. 080557C-000-JSS-1543-001 to be considered.
7. Trim Material shall be as per API Trim No 8.
8. (I) S.No 12: Valve shall be Eccentric/Rotary Plug Type fully Jacketed valve with end connection as follows:
  - (a) Valve end flange Bolt Centre Dia :- 8inch, 300#.
  - (b) Valve Process Dia of 6 inch.
 (II) For steam jacketing, valve will have 3/4" 300# steam in and steam out connection. Valve is jacketed using LP steam. LP Steam conditions are as follows:
  - Pressure (Operating / Design) Kg/cm2g:- 4 / 7 kg/cm2g
  - Temperature (Operating / Design) Kg/cm2g:- 175 / 240 °C
9. Valve Design shall be inherently Fire Safe.

				INSTRUMENT SPECIFICATION		 		
				ON OFF VALVE				
1	AK	07-08-2021	Re-issued with MR			Sheet 2	of 2	
0	AK	22-06-2021	Issued with MR					
No.	By	Date	Revision	Code:73	Dwg. No.:	B366-088-YC-DS-3222		Rev.: 1

 	<b>PROJECT</b> Standby SRU & Additional Tanks IOCL Paradip Refinery			
	<b>CLIENT</b> INDIAN OIL CORPORATION LIMITED			
<b>JOB SPECIFICATION FOR ON/OFF VALVES &amp; MOV</b>	<b>Project No.</b> 080557C001	<b>Document No.</b> 080557C-000-JSS-1543-001	<b>Rev. No.</b> D	Page 1 of 26

## JOB SPECIFICATION FOR ON/OFF VALVES AND MOV

REV.	DATE	DESCRIPTION	PREPARED	CHECKED	APPROVED	AUTHORIZED
D	11-06-2020	ISSUED FOR DESIGN	SGR	KRS	SS	JMC
C	23-01-2020	ISSUED FOR DESIGN	CRK	KRS	SS	JMC
B	25-11-2019	ISSUED FOR DESIGN	CRK	KRS	SS	JMC
A	18-10-2019	ISSUED FOR DESIGN	CRK	KRS	SS	JMC

This document is developed by TECHNIP India Limited and the information it contains is property of Indian Oil Corporation Ltd. It shall not be used for any purpose other than that for which it is supplied.

CONFIDENTIAL – Not to disclose without Authorization

 <b>TechnipFMC</b>	 IndianOil	<b>PROJECT</b>	<b>Standby SRU &amp; Additional Tanks</b>		
			<b>IOCL Paradip Refinery</b>		
		<b>CLIENT</b>	<b>INDIAN OIL CORPORATION LIMITED</b>		
<b>JOB SPECIFICATION FOR ON/OFF VALVES &amp; MOV</b>	<b>Project No.</b> 080557C001	<b>Document No.</b> 080557C-000-JSS-1543-001		<b>Rev. No.</b> D	Page 2 of 26

## TABLE OF CONTENTS

1. INTRODUCTION .....	4
2. GENERAL ABBREVIATIONS.....	4
3. TECHNICAL ABBREVIATIONS .....	5
4. CONFLICTS AND DEVIATIONS.....	5
5. REFERENCE NATIONAL / INTERNATIONAL STANDARDS.....	6
6. REFERENCE DOCUMENTS:.....	7
7. ENVIRONMENTAL.....	7
8. GENERAL REQUIREMENTS.....	7
9. AREA CLASSIFICATION .....	8
10. DESIGN AND CONSTRUCTION.....	8
10.1. General.....	8
10.2. Ball Valve Body .....	10
10.3. Butterfly Valve Body .....	10
Trim.....	11
10.5. Bonnet .....	11
10.6. Stem.....	12
10.7. Pneumatic Actuator .....	12
10.8. Accessories.....	13
10.8.1. Solenoid valves .....	13
10.8.2. Limit Switches.....	14
10.8.3. Air Filter Regulator.....	14
10.9. Electric Actuator - Motor Operated Valve .....	15
10.9.1. Smart MOV .....	15
10.9.2. Field Control Unit .....	15
10.9.3. Master Control Unit.....	16
10.9.4. Network Requirements.....	17
10.9.5. Performance Requirements .....	17
10.9.6. Operational Requirements.....	17
10.9.7. Motor.....	17

This document is developed by TECHNIP India Limited and the information it contains is property of Indian Oil Corporation Ltd. It shall not be used for any purpose other than that for which it is supplied.

 <b>TechnipFMC</b>	 IndianOil	<b>PROJECT</b>	<b>Standby SRU &amp; Additional Tanks</b>		
			<b>IOCL Paradip Refinery</b>		
		<b>CLIENT</b>	<b>INDIAN OIL CORPORATION LIMITED</b>		
<b>JOB SPECIFICATION FOR ON/OFF VALVES &amp; MOV</b>	<b>Project No.</b> 080557C001	<b>Document No.</b> 080557C-000-JSS-1543-001	<b>Rev. No.</b> D	Page 3 of 26	

10.9.8.	Integral Starter and Control Transformer .....	18
10.9.9.	Integral Push Button, Selector switches, Indications and Control devices .....	18
10.9.10.	Torque and Travel Limit Switches .....	18
10.9.11.	Control Facilities.....	19
10.9.12.	Interface with Owner's DCS/Remote Pushbutton Station .....	19
10.9.13.	Hand Operation.....	19
10.9.14.	Remote Position Indicator .....	20
10.9.15.	Wiring and Terminals .....	20
10.10.	Valve Jacketing.....	20
10.11.	Partial Stroke Testing.....	20
10.12.	Noise.....	20
10.13.	Special Service Valves .....	21
10.14.	Finish .....	21
11.	SPECIAL INSTRUCTIONS .....	21
11.1.	Valve NDE & NDT Requirements.....	22
11.2.	PMI Requirements:.....	22
11.3.	Sour and HIC service / NACE Requirements.....	22
11.4.	Hydrogen Service Requirement .....	22
11.5.	Indian Boiler Regulation (IBR) Requirements .....	22
11.6.	PTR Requirement .....	22
11.7.	Bolting and Gasket .....	22
12.	NAMEPLATE.....	23
13.	INSPECTION AND TESTING.....	23
13.1.	Hydrostatic Test .....	24
13.2.	Functional Tests.....	24
13.3.	Witness Inspection.....	24
14.	SPARES.....	25
15.	SHIPPING .....	25
16.	DOCUMENTATION.....	25
16.	GUARANTEE AND WARRANTY .....	26
	TYPICAL PARTIAL STROKE TESTING SCHEME.....	26

This document is developed by TECHNIP India Limited and the information it contains is property of Indian Oil Corporation Ltd. It shall not be used for any purpose other than that for which it is supplied.



		<b>PROJECT</b>	<b>Standby SRU &amp; Additional Tanks</b>		
		<b>CLIENT</b>	<b>INDIAN OIL CORPORATION LIMITED</b>		
<b>JOB SPECIFICATION FOR ON/OFF VALVES &amp; MOV</b>	<b>Project No.</b> 080557C001	<b>Document No.</b> 080557C-000-JSS-1543-001		<b>Rev. No.</b> D	Page 4 of 26

## 1. INTRODUCTION

**INDIAN OIL CORPORATION LIMITED (IOCL)** has awarded Fax of Acceptance (FOA) dated 29<sup>th</sup> August 2019 to M/s. Technip India Limited (TPIL) for Consultancy services (PMC/EPCM services) for overall project management, FEED Review / FEED, Detailed Engineering, Procurement & expediting services, Tendering & award, Construction Management & Supervision, Assistance in start-up, Commissioning & performance test runs for installation of a Standby SRU of 525 TPD capacity and execution of Additional tanks for Paradip Refinery, Odisha, India.

## 2. GENERAL ABBREVIATIONS

<b>Abbreviation</b>	<b>Definition /Expanded form</b>
IOCL/ CLIENT	Indian Oil Corporation Limited
PMC/ CONSULTANT	Technip India Limited
LICENSOR	Party selected by IOCL for process technology ownership for any UNIT
CONTRACTOR	Party whose services are obtained for performing the works specified as part of LSTK / packages.
EPCM	Engineering, Procurement & Construction Management Services.
LSTK	Lump Sum Turn Key portion of the work to be executed by CONTRACTOR
FEED	Front End Engineering Design
AUTHORISED REPRESENTATIVE	IOCL's/ CONSULTANT's representative authorized to act for and on behalf of them.
VENDOR	Any third party supplying the equipment/materials for setting up the Plant
PROJECT	Indicates Standby SRU and Additional tanks Project, Paradip Refinery
UNIT	Indicates any particular portion of the project to be built which can be Process related or Utilities/Offsites related
SRU	Sulphur Recovery Unit

 	<b>PROJECT</b>	<b>Standby SRU &amp; Additional Tanks</b>		
	<b>CLIENT</b>	<b>INDIAN OIL CORPORATION LIMITED</b>		
<b>JOB SPECIFICATION FOR ON/OFF VALVES &amp; MOV</b>	<b>Project No.</b> 080557C001	<b>Document No.</b> 080557C-000-JSS-1543-001	<b>Rev. No.</b> D	Page 5 of 26

### 3. TECHNICAL ABBREVIATIONS

AARH	Arithmetic Average Root Height
CCOE	Chief Controller Of Explosives
CMRI	Central Mining Research Institute
DCS	Distributed Control System
DPDT	Double Pole Double Throw
ERTL	Electronics Regional Testing Laboratory
FF	Foundation Fieldbus
HART	Highway Addressable Remote Transducer
MAWP	Maximum Allowable Working Pressure
MOV	Motor Operated Valve
NACE	National Association of Corrosion Engineers
NPS	Nominal Pipe Size
NPT	National Pipe Threads
OSHA	Occupational Safety and Health Administration
PESO	Petroleum and Explosives Safety Organisation
PID	Proportional, Integral and Derivative
PTFE	Poly Tetra Fluoro Ethylene
SPDT	Single Pole Double Throw
TSO	Tight Shutoff

### 4. CONFLICTS AND DEVIATIONS

If conflicting statements exist within this document or between this document and Design Basis, other applicable specifications, Standard Drawings, Industry standards, codes, etc., it shall be brought to Owner's / PMC notice for clarification and proper approval shall be obtained before implementation. Decision of Owner / PMC shall be final.

In case of contradiction between licensor specification, design basis and JSS, it has to be brought to the notice of Owner/PMC and Decision of Owner/PMC shall be binding on Contractor/Vendor.

In general, order of priority of the documents shall be as follows,



- Local regulatory and statutory requirement.
- Licensor Requirements (as applicable)
- Project specification and datasheets, wherever applicable.
- This specification and relevant equipment/system specification.
- Codes and standard.

 	<b>PROJECT</b>	<b>Standby SRU &amp; Additional Tanks</b>		
	<b>CLIENT</b>	<b>INDIAN OIL CORPORATION LIMITED</b>		
<b>JOB SPECIFICATION FOR ON/OFF VALVES &amp; MOV</b>	<b>Project No.</b> 080557C001	<b>Document No.</b> 080557C-000-JSS-1543-001	<b>Rev. No.</b> D	Page 6 of 26

## 5. REFERENCE NATIONAL / INTERNATIONAL STANDARDS

Design and terminology shall comply, as a minimum, with the latest edition of following codes, standard practices and publications:

ANSI/ASME	American National Standard Institute/American Society of Mechanical Engineer.
B 1.20.1	Pipe Threads, General Purpose (Inch)
B 16.10	Face to face or End to end dimensions of Valve
B 16.5	Pipe Flanges and Flanged Fittings
B 16.20	Metallic Gaskets for Pipe Flanges, Ring Joint, Spiral wound and Jacketed.
B 16.34	Valves – flanged, Threaded and Welding End.
Sec VIII	Rules for Construction of Pressure Vessels
ANSI FCI 70-2	Control valve seat leakage class
API 6 D	Pipelines valves (Gate valve, Plug, Ball and Check valves)
API 6FA	Specification for fire test of valves
API 598	Inspection Requirements
API 607	Fire safe test for Soft Seated Quarter Turn Valves
API 609	Lug and wafer type, Double flanged Butterfly valves
ASTM E-119/ BS-476/IS-3809	Fire Proofing
BS 6364	Valves in cryogenic service
DIN-19234	NAMUR standard (for Inductive proximity switches)
EN 10204	Inspection Documents for Metallic Products.
EN 61056-1	Specification for performance, design and construction of valve, regulated sealed type.
IBR	Indian Boiler Regulation.
IEC 60079	Electrical Apparatus for Explosive Gas Atmosphere.
IEC 60529	Degree of Protection Provided by Enclosures.
IEC 60534-8.3	Industrial process control valves, noise consideration, valve aerodynamic noise prediction method
IEC 60534-8.4	Industrial process valves, noise consideration, prediction of noise generated by hydrodynamic flow
IS 325	Three-phase Induction Motors
IS 4691	Degrees of protection provided by enclosure for rotating electrical machinery.
IS 5571	Guide for Selection of Electrical Equipment for Hazardous area.
IS 9334	Electric Motor Operated Actuators.
IS-2148	Flame proof enclosures for electrical apparatus for explosive Gas Atmospheres – Flame proof Enclosures ‘d’
IS 13947	Degree of Protection provided by Enclosures for low voltage switchgear and control gear.
ISO 5752	Metal valves for use in flanged pipe system face to face and center to face dimension.
ISO 15848	Measurement test for fugitive emission
ISO 10497	Specification for fire type testing requirements.
MSS SP25	Standard Markings System for Valves, Fittings, Flanges and Unions

 	<b>PROJECT</b> <b>Standby SRU &amp; Additional Tanks</b> <b>IOCL Paradip Refinery</b>			
	<b>CLIENT</b> <b>INDIAN OIL CORPORATION LIMITED</b>			
<b>JOB SPECIFICATION FOR ON/OFF VALVES &amp; MOV</b>	<b>Project No.</b> 080557C001	<b>Document No.</b> 080557C-000-JSS-1543-001	<b>Rev. No.</b> D	Page 7 of 26

OSHA

Occupational safety and health hazard

## 6. REFERENCE DOCUMENTS:

080557C-000-JSD-1540-001	Design Basis – Instrumentation -Tank
080557C-088-JSD-1540-002	Design Basis - Instrumentation
080557C -000-JSD-1300-002	Piping Material Specification
080557C -000-SP-1500-001	Data sheet formats (typical) for Instrumentation Items
080557C -000-STC-1590-001	Installation Standards for Tanks
080557C -000-JSS-1310-001	Job Supply Specification for Valves



## 7. ENVIRONMENTAL AND PROCESS PROTECTION

All valves and instruments mounted in the field shall have environmental protection to IEC 60529 - IP66 as a minimum, in areas not subject to flooding.

In areas subject to flooding e.g. pits, they shall be protected to IP67 or 68 as required. The selection of materials for in-line instrument such as control valves shall follow the associated piping material specification as a minimum.

## 8. GENERAL REQUIREMENTS

- 1) Valves design, manufacturing and testing shall be complete in all respects for the safe, efficient and easy operation, start up and shutdown of the units.
- 2) Solenoid valve, limit switch, MOV actuator and accessories shall be suitable for Zone-1 Gr. IIA & IIB, T3. as minimum as per IEC 60079 / IS 2148. For hydrogen service, shall be suitable for Zone-1 Gr. IIC T3. as minimum. However, in case hazardous area is Zone 0 as per area classification, offered Instruments shall be suitable for specific area, as identified.
- 3) All the instruments in Hydrogen Service shall be certified for use in Hydrogen service by the manufacturer specifically with respect to Hydrogen Diffusion. All the Instruments in NACE service shall meet specific material requirements like hardness, radiography, material requirements and material testing requirements as per ISO 15156. For specific requirements requiring PWHT, Ultrasonic test, Radiography etc., piping material specification shall be referred. Specific treatment (e.g.: Silicon-coating) shall be given to threads and stem to avoid Galling.
- 4) For HART signals, the preferred method of protection shall be Intrinsic Safety using galvanic (3 port active isolating type) isolators. The isolators shall have status indicating LED's. Dual channel devices shall not be used for conventional signals.
- 5) The isolators shall be in the equipment rooms / Control Room. If Intrinsic safety certification is not available, then Flame Proof Instruments shall be used and same shall be brought to the notice of Owner / PMC.

 	<b>PROJECT</b> <b>Standby SRU &amp; Additional Tanks</b> <b>IOCL Paradip Refinery</b>			
	<b>CLIENT</b> <b>INDIAN OIL CORPORATION LIMITED</b>			
<b>JOB SPECIFICATION FOR ON/OFF VALVES &amp; MOV</b>	<b>Project No.</b> 080557C001	<b>Document No.</b> 080557C-000-JSS-1543-001	<b>Rev. No.</b> D	Page 8 of 26

- 6) All electronics shall be protected against transients induced by lightning and power supply surges. Transient protection of electronics shall preferably be provided in the terminal block. The transient protection shall meet the requirements specified in IEC-60587. In case of external, limit switches, solenoid motor actuator etc., shall be Exd certified and plugged in Transmitter body. Universal type Transient protection device shall be provided.
- 7) Instrument systems shall be designed to avoid interaction between associated electrical circuits. Spurious signals that cause interference shall be suppressed, preferably at source.
- 8) Valves used on pipe and vessel under IBR services shall be tested and certified by IBR or IBR authorized representative as per Appendix 'L' of IBR.
- 9) All instruments wetted parts shall be SS 316 as minimum and Electronic housing material shall be of Epoxy coated die cast Aluminium.
- 10) Flying leads shall not be acceptable in any Instruments.
- 11) Inventory isolation valves and its associated accessories shall be provided as fire safe type.
- 12) Generally, fire protection can be provided using shields, casings or intumescent coatings (e.g. K-Mass).



## **9. AREA CLASSIFICATION**

- 1) Solenoid valve, limit switch, MOV actuator and accessories shall be suitable for Zone-1 Gr. IIA & IIB, T3, as minimum as per IEC 60079 / IS 2148. For hydrogen service, shall be suitable for Zone-1 Gr. IIC T3, as minimum. However, in case hazardous area is Zone 0 as per area classification, offered Instruments shall be suitable for specific area, as identified.
- 1) Certificate from statutory authority like BASEFFA, FM, PTB, ATEX and GENELEC etc. for items of foreign origin and from CMRI, ERTL etc. for items of Indian origin are required and shall be submitted. Also, Indigenous Flameproof equipment shall comply with BIS requirement.
- 2) All valves and instruments shall be certified by the Chief Controller of Explosives (CCOE), Nagpur, India, and an internationally recognised Authority as being EEx 'ia', 'ib', 'iaD', 'ibD', 'icD', dependant on area classification and whether the hazard is dust or vapour driven, as being compliant with IEC 60079 – 11.
- 3) MOV actuators shall be Explosion proof design (Exd), On/Off Valve Limit switches, solenoid valves shall be intrinsically safe design with electrical certification Exia.
- 4) For SIL rated valve and accessories, Vendor must furnish certified values of failure rates, probability of failure detection and test intervals for safety integrity level analysis. In addition to this, Vendor must furnish SIL certification from any statutory body like TUV, FMEDA as per IEC 61508.
- 5) Materials in contact with Plant Atmosphere shall be corrosion resistant.

## **10. DESIGN AND CONSTRUCTION**

### **10.1. General**

- 1) Valve type shall be selected considering factors such as operating and design conditions, fluid being handled, rangeability required, allowable leakage, noise and other special requirements.

 <b>TechnipFMC</b>	 IndianOil	<b>PROJECT</b>	<b>Standby SRU &amp; Additional Tanks</b>		
			<b>IOCL Paradip Refinery</b>		
		<b>CLIENT</b>	<b>INDIAN OIL CORPORATION LIMITED</b>		
<b>JOB SPECIFICATION FOR ON/OFF VALVES &amp; MOV</b>	<b>Project No.</b> 080557C001	<b>Document No.</b> 080557C-000-JSS-1543-001	<b>Rev. No.</b> D	Page 9 of 26	

- 2) Ball valves are preferred but where process conditions dictate, other valve body design may be employed, subject to approval by IOCL
- 3) Material of construction of Body and Bonnet for the on-off valve shall be the same.
- 4) All valves shall be flanged type, flanges shall be in accordance with ANSI B16.5. Valve body material, flange type, rating and finish shall confirm to the piping specification. Valve body and flange rating shall be minimum 300#.
- 5) All ESD and Depressurizing valves shall be metal seated Fire Safe Design with seat leakage rate shall not exceed ISO 5208 Rate D.
- 6) Valves having soft components (stem, seat or body seals) shall be of fire tested design in accordance with ISO 10497 and provided with appropriate certification. For valves that have been type tested before 2005, testing in accordance with BS 6755 Part 2, ISO 10423 (API 6A) is acceptable.
- 7) Leakage for soft-seated valves shall not exceed ISO 5208 Rate A (no visible leakage). Face to face dimensions shall be as per ASME B16.10
- 8) Unless otherwise mentioned, end connection details shall be as below
  - a. Valves up to NPS 600 mm shall be flanged to ANSI B16.5 and to ANSI B16.47 for valves larger than NPS 600 mm. All flanges shall be drilled for through bolting. Flanges which are drilled and tapped for studs are not acceptable.
  - b. Gasket surface finish for raised face flanges shall be serrated concentric as per clauses 6.4.4.1, 6.4.4.2 and 6.4.4.3 of ANSI B 16.5. The face finish shall be as follows:
 

125 AARH :	125 to 200 AARH
63 AARH :	32 to 63 AARH.
  - c. Ring type joint flanges shall have octagonal grooves as per ANSI B 16.20.
- 9) Vendor shall be responsible for selecting proper material for the internal parts of the valve. All such materials shall have the same or better suitability for the specified process condition.
- 10) On/Off valve accessories such as air filter regulators, solenoid valve, limit switch, air lock relay, booster etc. shall be properly mounted on the actuators and shall be supplied in fully tube condition
- 11) Tube fittings shall be Swagelok/Parker double compression type in SS 316 material.
- 12) Material used for trim shall be AISI-316 or better.
- 13) On/off valves leakage test method shall be as per API 598 STD.
- 14) On-Off valves, inherent characteristic shall be On-Off Type (Quick Opening Type).
- 15) On-Off valves shall be of the anti-static type and provided with a blow out-proof shaft guiding design.
- 16) As a prequalification, Fire safe test shall be as per API607/ BS 6755 Part 2/ ISO10497-5/ API 6FA latest editions.
- 17) Noise from On-Off valve during operating condition shall be limited to OSHA specified limit or better. The predicted aerodynamic noise level at a 1 meter radius from the valve discharge flange shall not be greater than 85 DBA. Noise abatement shall in the first instance to be achieved by judicious selection of the trim design. Where this cannot be achieved by trim design alone, path treatment- example Heavy wall pipe/ external insulation/ Silencers may be considered for localised abatement.

		<b>PROJECT</b>	<b>Standby SRU &amp; Additional Tanks</b>		
			<b>IOCL Paradip Refinery</b>		
		<b>CLIENT</b>	<b>INDIAN OIL CORPORATION LIMITED</b>		
<b>JOB SPECIFICATION FOR ON/OFF VALVES &amp; MOV</b>	<b>Project No.</b> 080557C001	<b>Document No.</b> 080557C-000-JSS-1543-001	<b>Rev. No.</b> D	Page 10 of 26	

- 18) Depressurization valve actuators shall normally be designed to fail open, shall be fitted with 2 solenoid valves piped and wired to be “fault tolerant” and have discrete local reserve air cylinders.
- 19) All valves shall have direction of the flow through the valve stamped or cast on the valve body. For three way valves, position shall be indicated with identification of port connection

## 10.2. Ball Valve Body

- 1) On-Off Ball valves shall be flanged only, threaded or butt-welded are not acceptable.
- 2) Ball valve design shall be as per API 6D with minimum flange rating of 300#.
- 3) Ball valve for shutdown applications shall normally be full Bore Ball type unless specified otherwise. The valves shall be of the anti-static type and provided with a blow out-proof system. In general, ball valve shall be of the floating ball design, however in applications with high pressures and/or when the valve size makes the ball too heavy to float adequately, trunion shall be used. Ball valves on dirty services shall also be trunion mounted.
- 4) Ball valves shall be floating ball type / Trunion mounted type as per following:

300#	4" & Below	Floating Ball
	6" & above	Trunion mounted
600# and above	1.5" & below	Floating Ball
	2" & above	Trunion mounted

- 5) In each instance, the vendor shall select the method of ball support to suit the applicable piping classes and process conditions.

## 10.3. Butterfly Valve Body

- 1) The minimum nominal sizes of butterfly valves shall be equal to or greater than 8" with minimum 300# rating.
- 2) Butterfly valves shall be double flanged, triple offset design with minimum rating of 300#. Threaded or butt-welded or Lug design or Wafer on-off valves are not acceptable.
- 3) Wafer design is not acceptable. Butterfly valves shall comply with API 609 STD.
- 4) Face to face dimensions shall be in accordance with API609/ ANSI B16.10/ISO5752 series13/ ISO5752 series 14.
- 5) All butterfly valves shall, as a minimum, be fitted with stainless steel 316 vanes and shafts in a precipitation hardened material (e.g. 17-4 PH).

 <b>TechnipFMC</b>	 IndianOil	<b>PROJECT</b>	<b>Standby SRU &amp; Additional Tanks</b>		
			<b>IOCL Paradip Refinery</b>		
		<b>CLIENT</b>	<b>INDIAN OIL CORPORATION LIMITED</b>		
<b>JOB SPECIFICATION FOR ON/OFF VALVES &amp; MOV</b>	<b>Project No.</b> 080557C001	<b>Document No.</b> 080557C-000-JSS-1543-001	<b>Rev. No.</b> D	Page 11 of 26	

#### 10.4. Trim

- 1) The term 'trim' covers those parts of body assembly (excluding the body, bonnet) which are exposed to and are in contact with the line medium consisting of but not limited to disc/ball, seat ring, shaft and guide bushing.
- 2) On/Off valves like butterfly, segmental ball, eccentric rotary plug etc. shall have blowout proof shaft guiding design.
- 3) Guide bushings shall be of a sufficiently hard material to resist side thrust on the plug.
- 4) Unless otherwise stated, General valve trim shall be constructed from 316 SS. However, the use of trim materials such as Stellite faced 316 SS, 17-4 PH, 440C, Hastelloy C, Monel or tungsten Carbide coated 316 SS etc should be considered in the following applications:
  - a. Erosive service
  - b. Corrosive service
  - c. Slurry service
  - d. Wet Gas or Steam service
- 5) Whenever stellite trim is specified following material of construction for the trim parts shall be acceptable.
  - a. Plug/Disc and seat      Stellite sheathing/coating or solid stellite
  - b. Guide bushing, seal      Stellite coating/sheathing or solid stellite  
ring and sealing area
- 6) Whenever hardened SS trim is required for process condition, following material of construction for the trim parts shall be acceptable provided same are compatible with the specified process conditions;
  - a. Plug/Disc and seat      Stellite sheath /coating or 17-4PHSS or 440C
  - b. Guide bushing, seal      440C, 316SS stellite, 17-4 PHSS or solid stellite  
ring and sealing area
- 7) Minimum acceptable hardness in case of stellite or hardened trim shall be of the order of RC 45 or BHN 429.
- 8) For ease of maintenance, all valve trims shall be of the quick-change type, with no internal components screwed or welded into the valve bodies or bonnets.
- 9) Wherever Tight Shut Off is specified, leakage class shall be Class VI for soft seat material and shall be Class V for metal seated.

#### 10.5. Bonnet

- 1) Generally, stem seals shall comprise of a bolted packing box assembly, designed to allow the packing to be adjusted or completely removed without having to disturb any other components of the valve assembly.
- 2) Where process streams containing Toxic / Volatile Organic Compounds (VOCs) are specified the valve may require special low emission valve packing and / or bellows sealing.
- 3) The type of packing / sealing selected shall be compatible with the process and environmental conditions prevailing for each given application. Generally, the type of packing shall be selected in accordance with the following temperature limits:

 <b>TechnipFMC</b>	 IndianOil	<b>PROJECT</b>	<b>Standby SRU &amp; Additional Tanks</b>		
			<b>IOCL Paradip Refinery</b>		
		<b>CLIENT</b>	<b>INDIAN OIL CORPORATION LIMITED</b>		
<b>JOB SPECIFICATION FOR ON/OFF VALVES &amp; MOV</b>	<b>Project No.</b> 080557C001	<b>Document No.</b> 080557C-000-JSS-1543-001		<b>Rev. No.</b> D	Page 12 of 26

Temperature Range	Packing Material
-40 to +230 °C	PTFE V-Rings
Above +230 °C	Graphite in pre-formed rings (non-asbestos)

- 4) Extension bonnets shall be considered for design temperatures below 0 Deg C and above 230 Deg C. (Higher temperature range limit can vary with supplier with proper justification and PTR)

#### 10.6. Stem

- 1) The stem surface finish shall be fine. Extra fine surface finish shall be provided wherever the packing material is PTFE.
- 2) The stem/shaft shall be designed for the maximum thrust of the actuator without any measurable deflection.
- 3) The valve stem/shaft shall be connected to the actuator stem/shaft by suitable arrangement to avoid backlash problem.

#### 10.7. Pneumatic Actuator

- 1) On/Off valve actuators shall be pneumatically driven and wherever possible a single stroke spring return design shall be followed. Sizing shall be based on an air supply of 3.5 kg/cm<sup>2</sup>g. The torque requirement calculation shall include a 1.5 safety factor, in addition to the basic valve torque, factors for seat material, fluid, and operational frequency. Hand wheels shall not be fitted.
- 2) Unless stated otherwise, valve closing speeds shall be:  
15 – 65 mm valve size : 2 seconds  
80 – 150 mm valve size : 3 – 6 seconds: depends on size  
200 – 600 mm valve size : 8 – 24 seconds: depends on size
- 3) For special type valve stroking time, as per licensor/project requirement shall be followed as applicable.
- 4) All actuators shall be adequate to fully stroke the value under the maximum differential pressure specified by the process requirement at the minimum instrument air pressure.
- 5) Actuator shall be selected considering instrument air supply pressure of 3.5 Kg/cm<sup>2</sup>g.
- 6) The actuator shall be sized using a safety factor of 1.5 which means that the maximum torque needed for a valve stroke (information given by On/Off valve Vendor) will be multiplied by 1.5 at any point of the valve stroke curve, to obtain the minimum required actuator torque value at the minimum air pressure.
- 7) Shear torque of stem/shaft greater than 1.5 x maximum torque produced by actuator at maximum air supply pressure
- 8) The actuator torque at the maximum pressure supply shall not exceed the maximum allowable torque on both the valve and actuator stem.

The vendor shall provide torque data to verify the matching of the actuator to the valve.

Data shall include :

- a) Breaking torque required to commence movement of the valve
- b) Running torque
- c) End of travel torque

 <b>TechnipFMC</b>	 IndianOil	<b>PROJECT</b>	<b>Standby SRU &amp; Additional Tanks</b>		
			<b>IOCL Paradip Refinery</b>		
		<b>CLIENT</b>	<b>INDIAN OIL CORPORATION LIMITED</b>		
<b>JOB SPECIFICATION FOR ON/OFF VALVES &amp; MOV</b>	<b>Project No.</b> 080557C001	<b>Document No.</b> 080557C-000-JSS-1543-001	<b>Rev. No.</b> D	Page 13 of 26	

- d) Shear torque of stem/shaft
  - e) Actuator torque at minimum air supply pressure
  - f) Actuator torque at maximum air supply pressure (MAWP)
- 9) Sizing of actuators shall be solely the responsibility of the Vendor. The actuator shall be sized to provide sufficient force to position and fully stroke the valve trim against the maximum differential pressure that may be developed under the specified operating conditions with minimum air pressure available.
  - 10) Actuator shall be designed to withstand for maximum instrument air supply pressure 10 Kg/cm<sup>2</sup>g.
  - 11) Actuator casing shall be made of carbon steel. Non-metallic actuator casings shall not be offered.
  - 12) Springs shall be corrosion-resistant and shall be cadmium or nickel-plated. These shall be of the enclosed type. The compression of the springs shall be adjustable.
  - 13) Pneumatic Piston actuators shall be used on all ESD applications. They shall preferably be the single acting return design. Double-acting piston actuators may only be used with owner's/PMC approval.
  - 14) On/Off valve actuators shall be provided with mechanical position indicating devices, matching the true position of the valve. The mechanical position indicator installation shall be tamperproof and shall be easily readable.
  - 15) Wherever double piston actuator required, volume tank shall be supplied by the vendor. Volume tank shall meet the following requirements:
    - i. Volume tank shall be sized for minimum three full stroke operation of On-Off.
    - ii. Volume tank shall be designed to comply with ASME Section VIII with design pressure of 10kg/cm<sup>2</sup> g as a minimum
    - iii. Each volume tank shall be provided with Safety Valve, Non-return Valve, Pressure Transmitter for alarm in the Control Room.
    - iv. The volume tank shall be of stainless steel construction. Accessories like pressure relief valves and tube fittings including brackets, fixings and fittings shall be of 316 Stainless steel construction.
  - 16) Actuator orientation shall suit the site conditions, in general maintenance access shall be studied while specifying the Actuator orientation. It shall be possible to change this orientation at site for the offered valve-actuator combination in case it is found necessary.

## **10.8. Accessories**

### **10.8.1. Solenoid valves**

- 1) Solenoid valves shall be mounted on the actuator. Pneumatic connection, and orifice diameter shall be selected by the vendor considering the valve stroking time. Solenoid valves shall be used as the pilot valve to trip the valve.
- 2) Solenoid valves, wherever used, shall be direct acting three-way universal type, auto reset and shall be continuous rated type with class H coil insulation as per IEC 60085.
- 3) Solenoid valve shall be with surge suppression diodes. Flying leads are not acceptable. Proper terminal blocks shall be provided for cable termination.

 	<b>PROJECT</b> <b>Standby SRU &amp; Additional Tanks</b> <b>IOCL Paradip Refinery</b>			
	<b>CLIENT</b> <b>INDIAN OIL CORPORATION LIMITED</b>			
<b>JOB SPECIFICATION FOR ON/OFF VALVES &amp; MOV</b>	<b>Project No.</b> 080557C001	<b>Document No.</b> 080557C-000-JSS-1543-001	<b>Rev. No.</b> D	Page 14 of 26

- 4) The solenoid valve operating voltage shall be 24V DC operated. Solenoid valves shall be low power consumption type.
- 5) Solenoid valve shall be Ex-ia, SIL-3 certified.
- 6) Cable entry shall be 2 nos ½" NPT-F. SS 304 Cable gland and plug shall be provided for cable entry. Cable gland and plug shall be Ex-e & Ex-d dual certified and double compression type. Atmospheric vents shall be fitted with bug screens.
- 7) Solenoid valve body, trim material shall be SS 316. Electronic enclosure shall be Die cast Aluminium. The enclosure shall contain the required terminal blocks for cable termination.
- 8) Pilot operated solenoid valves are not permitted.

#### 10.8.2. Limit Switches

- 1) Limit switches wherever applicable shall be supplied with valve to indicate open and close position of the valve. Limit switches shall be mounted on the actuator yoke. Limit switches shall be proximity(inductive) type as per NAMUR DIN 19234, separate for open/close position of the valve. Limit switches shall be actuated directly from the valve stem or shaft must be adjustable and shall not be affected by the vibration.
- 2) On/Off valve limit switches shall be external to the actuator, shall not be integral part of actuator.
- 3) All valves shall be supplied with a high visibility mechanical position indicator for easy verification of the valve position status.
- 4) Limit Switches shall be intrinsically safe Ex(ia) certified. Limit switches shall be 2-wire installed in the junction box, enclosure material shall be die-cast Aluminium and ingress protection class shall be minimum IP-66 as per IEC 60529. Terminal blocks shall be anti-vibration terminal block suit for 2.5 sq.mm.
- 5) Each junction box shall have two cable entries of min. ½" NPTF for open and close limit switches. Cable gland/plug material shall be SS304. Cable gland shall be Ex-e/Ex'd', double compression type.

#### 10.8.3. Air Filter Regulator

- 1) Vendor shall supply air filter regulator of suitable size, range and capacity with each valve.
- 2) Regulator shall be provided with manual drain and 2" nominal size pressure gauge (pressure gauge case shall be of SS).
- 3) Air filter regulator shall be sized considering the air supply pressure and flow of the plant Instrument air supply.
- 4) Filter material shall be sintered bronze. Filter size shall be maximum 5 microns.
- 5) Regulator body material shall be SS 316 including drain valve, screw etc.,
- 6) Vendor shall supply 10mm OD with 1 mm thick SS 316L tubes as per ASTM A269 seamless type. All instrument air tube fittings shall be SS 316 as a minimum and shall be Swagelok/Parker make. Compression fittings shall be double ferrule type.

 	<b>PROJECT</b> <b>Standby SRU &amp; Additional Tanks</b> <b>IOCL Paradip Refinery</b>			
	<b>CLIENT</b> <b>INDIAN OIL CORPORATION LIMITED</b>			
<b>JOB SPECIFICATION FOR ON/OFF VALVES &amp; MOV</b>	<b>Project No.</b> 080557C001	<b>Document No.</b> 080557C-000-JSS-1543-001	<b>Rev. No.</b> D	Page 15 of 26

- 7) Pneumatic connection for air filter regulator shall be ¼” or ½” NPT (F), unless higher size is required to meet the stroking time.

### 10.9. Electric Actuator - Motor Operated Valve

Each MOV actuator shall include the motor, actuator unit, gears, position indicators, limit switches, handwheel, electrical starter and controls, terminal box etc. as a self-contained unit.

The actuator shall be sized to provide adequate torque and/or thrust to ensure the complete intended travel of the valve under the worst operating and electrical power supply conditions.

The enclosure of complete MOV actuator including motor, integral starter, control transformer unit and all control devices shall be Ex d certified and shall have minimum IP-66 degree of protection which shall include the ‘O’ ring for complete environmental protection.

#### 10.9.1. Smart MOV

- MOV actuator if specified shall be of smart type able to interface over a communication network
- The control system shall be complete in all respect to execute all controls and provide data on all operation variables for the actuator for the safe and efficient operation of the Motor operated valves.
- The system shall basically consist of a control room mounted central control unit communicating to various field interface modules (located inside individual Motor operated Valve actuator housing) over a communication network.
- The control system shall be capable of controlling a minimum of 120 field devices over a single network of total loop length of 3000 meters meeting the performance requirement specified in clause 2.5 here under.
- All field mounted electronic modules (within actuator housing) shall be suitable for operating within 100 C (Min) to 340 C (Max) ambient temperature (Storage at 00 C to 500 C) and non-condensing Relative humidity of 40% (Min) and 87% (Max).

#### 10.9.2. Field Control Unit

- The field control unit shall be integral to actuator and shall be powered from the actuator power supply. No separate power supply shall be provided for operation of field unit. The field control unit shall be able to execute the following operational commands
  - Fully Open/Close control
  - Inching control
  - Emergency shut down (Hardwired contacts from Purchaser’s DCS/Host computer shall be provided for ESD actuation) Emergency shut down (ESD) signal shall over-ride any other signal command including motor winding temperature bypass.
- It shall be possible to re-configure the valve settings locally without opening the actuator cover.

Following signals and alarms shall be transferred by field control unit over the network:

 	<b>PROJECT</b> <b>Standby SRU &amp; Additional Tanks</b> <b>IOCL Paradip Refinery</b>			
	<b>CLIENT</b> <b>INDIAN OIL CORPORATION LIMITED</b>			
<b>JOB SPECIFICATION FOR ON/OFF VALVES &amp; MOV</b>	<b>Project No.</b> 080557C001	<b>Document No.</b> 080557C-000-JSS-1543-001	<b>Rev. No.</b> D	Page 16 of 26

- Continuous valve position
- Valve opening
- Valve closing
- Valve open
- Valve close
- Valve stopped
- Local push button depressed
- L/R in remote
- Torque switch tripped
- Loss of main power
- Loss of control power

In addition to above the following diagnostic alarms shall also be transferred:

- Actuator fault
- Field unit fault
- Loss of phase
- Thermostat tripped
- Torque switch tripped
- Valve jammed
- Contactor fails to energize

Actuator/ field control station shall accept hardwired contacts for emergency operation or emergency shutdown operation of the valve in addition to serial two-wire signal.

### **10.9.3. Master Control Unit**

- 10.9.3.1. Central control unit shall be microprocessor-based unit complete with a dedicated keyboard and a display unit. It shall be possible to operate the actuators and configure the network devices from the keyboard/display unit. Protection shall be provided in the central control unit for selecting configuration mode.
- 10.9.3.2. Central control unit shall be with dual redundant configuration in such a way that failure of one unit shall automatically transfer the control to the redundant unit. The switch over time shall be of the order of 100 msec. The output shall hold to the last state during switch over.
- 10.9.3.3. The system software shall include all software necessary for operation, displays and configuration of the complete system, along with software for communication with DCS/ Host computer. Software shall also be provided for the detailed diagnostics within the system including in the master control unit and in the network. The system shall also be capable to display all diagnostic alarms including those for field control units, network and of central control unit. Diagnostics shall also identify and display the exact location of network fault.
- 10.9.3.4. The system shall operate satisfactorily at 110 V  $\pm$  10% 50 Hz  $\pm$  3% power supply, unless specified otherwise elsewhere in the document.
- 10.9.3.5. The system configuration shall be stored in the retentive memory. Communication with Distributed Control System /HOST computer
- 10.9.3.6. The master control unit (Slave) shall provide RS 485 port with MODBUS protocol for transferring data to DCS / host computer (Master). Redundant ports shall be provided for this connectivity.
- 10.9.3.7. It shall be possible to transfer data to and from the DCS to master control unit through this connectivity.
- 10.9.3.8. It shall be possible to include or delete any of the MOV from the system from Master

 	<b>PROJECT</b> <b>Standby SRU &amp; Additional Tanks</b> <b>IOCL Paradip Refinery</b>			
	<b>CLIENT</b> <b>INDIAN OIL CORPORATION LIMITED</b>			
<b>JOB SPECIFICATION FOR ON/OFF VALVES &amp; MOV</b>	<b>Project No.</b> 080557C001	<b>Document No.</b> 080557C-000-JSS-1543-001	<b>Rev. No.</b> D	Page 17 of 26

Control Station.

#### **10.9.4. Network Requirements**

All field units shall be connected to master control unit using 2 wire networks, consisting of 1 twisted pair, shielded, 1.5 mm<sup>2</sup> Cu conductor cable being provided by the purchaser. Vendor shall check the suitability of this cable and calculate system performance parameters accordingly.

Vendor shall indicate the Network topology proposed by them. It may be noted that to reduce cable lengths 'Daisy Chain' type interconnectivity between field devices is preferred; also, the network length indicated in clause 10.9.1 is based on this type of connectivity.

The network communication protocol shall be Full Duplex type and shall incorporate a robust mechanism viz. CRC etc. to identify proper data transfer.

The network shall be designed to allow uninterrupted data transfer even in case of network failure (discontinuity in cable failure of one field module etc.) at a single point.

Proper isolation shall be provided for all the network connectors to avoid electrical interface problems.

#### **10.9.5. Performance Requirements**

The system shall be designed and engineered so as to provide reliable two-way communication between the Host computer, the control station and the Field modules The communication speed of the network should be selected so as to maintain data integrity even in case of the worst case of data transfer conditions. In any case the Maximum data transfer time for any command from central control unit to field station and vice versa shall not exceed 5 seconds for the network length and no of devices given above in clause 10.9.1

#### **10.9.6. Operational Requirements**

All MOVs shall have the provision for wiring both the two-wire network from Master control station as well as wiring hardwired ESD inputs directly from Purchaser's DCS/Host computer. Normal operational commands, status indications and diagnostic alarms shall be routed to Master Stations over a two-wire system. Whereas ESD inputs shall override any other command and close the MOV on its actuation.

#### **10.9.7. Motor**

The Motor shall be 3-phase squirrel cage induction type unless otherwise specified. It shall have totally enclosed non-ventilated and surface cooled construction.

The motor shall be designed for valve actuator service with high starting torque and shall be suitable for direct on line starting. It shall be rated for S2- 15-minute duty and shall conform to IS 325 or equivalent international standards.

The actuator assembly shall be provided with thermostat(s) embedded in it to achieve protection of motor against over-temperature.

The motor shall be suitable for starting under required torque with 75% of rated voltage at motor terminals

 	<b>PROJECT</b> <b>Standby SRU &amp; Additional Tanks</b> <b>IOCL Paradip Refinery</b>			
	<b>CLIENT</b> <b>INDIAN OIL CORPORATION LIMITED</b>			
<b>JOB SPECIFICATION FOR ON/OFF VALVES &amp; MOV</b>	<b>Project No.</b> 080557C001	<b>Document No.</b> 080557C-000-JSS-1543-001	<b>Rev. No.</b> D	Page 18 of 26

The motor shall have class 'F' insulation with temperature rise limited to class 'B' limits. Motor winding shall be treated to resist corrosive agents and moisture.

Motor enclosure shall preferably be of anodized Aluminium and, if brazed, shall be free from phosphorous.

Motor installed in actuator shall be rated for minimum of 60 starts/stop per hour. This is minimum requirement of actuator envisaged for On-OFF duty only.

In case of intrusive type actuator, anti-condensation heater shall be provided irrespective of IP-66 enclosure. However, in case of non-intrusive type actuator, space heater is not required.

Motor Shall be suitable for

- 1) Minimum 8 Nos of consecutive start in hot condition
- 2) Minimum 8 Nos of consecutive start in time span of 15 mins.

#### 10.9.8. Integral Starter and Control Transformer

The reversing starter, control transformer and local controls shall be integral with the valve actuator, unless specified otherwise. Solid state control of valve actuator and electrically isolated interface for remote control requirement shall be provided,

The integral starter shall be supplied with the following devices:

- i. Electrically and mechanically interlocked reversing contactors for opening and closing operations  
Control voltage shall be 24 Vdc floating.
- ii. Control transformer with necessary tapping and protected with suitable easily replaceable fuses.
- iii. Terminal block for external cable connection fully prewired for internal devices of valve actuator.
- iv. MOV actuators operating with AC power supply shall be provided with Instantaneous Phase reversal protection.

#### 10.9.9. Integral Push Button, Selector switches, Indications and Control devices

The following local control device shall be provided integral with the MOV actuator:

- i. Push buttons for 'Opening/Closing/Stop' or alternatively 'Open/Close' selector switch
- ii. 'Local/Off/Remote' selector switch, pad-lockable in each position. The contact shall be rated for 2A@24V Dc
- iii. Local continuous position indication from 'Valve fully open' to Valve fully closed' position, which may be of analogue or digital type using mechanical indication/Indicating lamps/LEDs.

#### 10.9.10. Torque and Travel Limit Switches

Torque limit switches shall be provided to protect the motor from over-loading by cutting-off the power supply to motor during opening and closing operations. The limit switches shall be preset, However, it shall be possible to set the value of maximum torque during closing from 50% to 100% of rated torque of actuators. Travel limit switch shall be provided to cut-off the power supply to the motor at the end of preset limit of valve travel. The switches shall be provided with requisite number of potential-free contacts for

 	<b>PROJECT</b> <b>Standby SRU &amp; Additional Tanks</b> <b>IOCL Paradip Refinery</b>			
	<b>CLIENT</b> <b>INDIAN OIL CORPORATION LIMITED</b>			
<b>JOB SPECIFICATION FOR ON/OFF VALVES &amp; MOV</b>	<b>Project No.</b> 080557C001	<b>Document No.</b> 080557C-000-JSS-1543-001	<b>Rev. No.</b> D	Page 19 of 26

valve actuator operation and for indication on remote panels. Instead of mechanical torque limit switches, magnetic pulse counter/encoders to measure and control the stroke of actuator may be provided, wherever this feature exists in manufacturer's design.

#### 10.9.11. Control Facilities

The internal controls and monitoring circuits shall be incorporated within the integral starter along with transformer and control unit of valve actuator.

Remote control facility shall be provided as a standard feature. The remote-control circuits shall be powered from internally derived control supply voltage. Common status contact indicating the availability of the MOV actuator for remote control shall be provided by monitoring the following:

- Loss of one or more phases of power supply
- Loss of control circuit supply
- Selector switch in local mode
- Local stop push button set to 'Off'
- Motor thermostat tripped
- Any other local fault/abnormal condition.

Where applicable, one number hand-held infrared/blue tooth remote programming device required for site commissioning and reconfiguring (without the need of removal of the MOV cover) shall be supplied for each group of 10 valve actuators (subject to minimum one infrared/Bluetooth remote setting device, even if number of valve actuators are less than ten)

#### 10.9.12. Interface with Owner's DCS/Remote Pushbutton Station

As a minimum as specified in project requirements, PID and licensor document, Potential free contact for the following shall be provided in actuator assembly for hardwire interface with Owner's DCS and/or Remote Push button station.

- Run indication
- Trip indication -
- Open status - 2 Nos.
- Close status - 2 Nos.
- Ready to start indication
- Torque high indication
- Thermostat status
- Open command
- Close command
- Local/Remote
- Intermediate Valve position
- Valve Opened through

#### 10.9.13. Hand Operation

A hand wheel with hand/auto lockable lever shall be provided for emergency operation of the MOV. the energization of the motor shall automatically re-engage power operation.

		PROJECT	Standby SRU & Additional Tanks		
		CLIENT	INDIAN OIL CORPORATION LIMITED		
JOB SPECIFICATION FOR ON/OFF VALVES & MOV	Project No. 080557C001	Document No. 080557C-000-JSS-1543-001	Rev. No. D	Page 20 of 26	

#### 10.9.14. Remote Position Indicator

If requirement of remote position indication is specified, a 4-20 mA remote position transmitter shall be provided in the valve actuator and a continuous position indicator for mounting in remote panel shall be supplied as a loose item, the remote position indicator shall continuously indicate the position of travel of the valve.

#### 10.9.15. Wiring and Terminals

All devices provided in the actuator shall be wired up to the terminal block. The contacts for remote operation and indication shall also be wired up to the terminal block. Minimum 10% spare terminals shall be provided for future interlocks. internal wiring for power and control circuits shall be appropriately sized for MOV actuator rating. Each wire shall be identified at both ends using PVC ferrules. The terminal compartment shall be separated from the inner electrical components of the actuator by means of a watertight seal so that the actuator electrical components are protected from the ingress of moisture and foreign materials when the terminal cover is removed during installation and maintenance.

The actuator shall be provided with minimum five adequately sized cable entries viz., one for power cable and two for control cables. Suitable double compression cable glands shall be provided with each actuator for all cable entries and sealing plugs for all control cable entries. The cable glands and plugs shall be of double compression type made of SS 316. Plastic plugs shall not be acceptable.

#### 10.10. Valve Jacketing

- 1) The jacketed valves shall have steam inlet/outlet and drain connections as flanged. Drain shall be provided with suitable blind flange.
- 2) The valve end connections shall be one size higher than the normal valve connections for jacketed valve.
- 3) For steam jacketed valves, all materials including testing and certification shall meet the requirements of Indian Boiler regulation.
  - i. Material shall be as per IBR 282.
  - ii. IBR-Form IIIC by IBR Authority shall be furnished by vendor.
  - iii. Radiography as applicable.

#### 10.11. Partial Stroke Testing

For ESD Valves of SIL 2 or higher, proprietary partial valve stroke testing mechanisms shall be provided as per the typical Partial Stroke Testing Scheme attached with this document. This mechanism shall include the use of an intelligent valve positioner and shall enable the valve to be stroked partially (adjustable set point) without upsetting normal process operation.

Partial stroke testing shall be from the DCS and shall also can transmit full valve diagnostics and predictive maintenance data to the Asset Management System. All necessary licenses on software shall be supplied by vendor.

#### 10.12. Noise

- 1) Vendor shall examine each valve for noise generation possibilities.

 	<b>PROJECT</b> <b>Standby SRU &amp; Additional Tanks</b> <b>IOCL Paradip Refinery</b>			
	<b>CLIENT</b> <b>INDIAN OIL CORPORATION LIMITED</b>			
<b>JOB SPECIFICATION FOR ON/OFF VALVES &amp; MOV</b>	<b>Project No.</b> 080557C001	<b>Document No.</b> 080557C-000-JSS-1543-001	<b>Rev. No.</b> D	Page 21 of 26

- 2) Noise generated by valve during operation shall be limited to OSHA specified levels i.e. the maximum allowable noise shall be less than 85 dBA, as measured at a distance of one meter from the valve.

### 10.13. Special Service Valves

All valves in oxygen and chlorine service shall be thoroughly degreased using reagents like trichloroethylene or carbon tetra-chloride. End connections shall be blinded / plugged after this degreasing process in order to avoid entrance of grease and oil particles.

### 10.14. Finish

- 1) Steel Valve bodies and top works shall be painted. Steel Valve bodies and topworks shall be painted in accordance with Painting Specification  
The top works shall be painted in the following colours:

Air Failure Closed - Red  
Air Failure Open - Green  
Air Failure Locked - Orange

Austenitic stainless steel and non-ferrous valves shall not be painted.

Carbon steel body - Light grey  
Alloy steel body - Canary yellow  
Stainless steel body - Natural

Items like silencers, diffuser plate assemblies etc., shall be painted as per respective valve body requirements.

The actuator shall be painted as below:

Direct (Open on Air Failure) - Green  
Reverse acting (Close on Air failure) - Red

Items like air volume tanks etc., supplied as an accessory along with the actuators, shall be painted as per corresponding actuator.

## 11. SPECIAL INSTRUCTIONS

Selection of the correct model numbers for the valve, actuator, solenoid valves shall be entirely the responsibility of the Contractor, if any discrepancies are found between model numbers and specifications of offered devices at any stage after placement of LOI/order, same shall be rectified by Contractor without any price and time implications.

Unused electrical cable entries shall be plugged with recessed head screw in full compliance with the applicable explosion proof classification and ingress protection level of the respective component.

 	<b>PROJECT</b> <b>Standby SRU &amp; Additional Tanks</b> <b>IOCL Paradip Refinery</b>			
	<b>CLIENT</b> <b>INDIAN OIL CORPORATION LIMITED</b>			
<b>JOB SPECIFICATION FOR ON/OFF VALVES &amp; MOV</b>	<b>Project No.</b> 080557C001	<b>Document No.</b> 080557C-000-JSS-1543-001	<b>Rev. No.</b> D	Page 22 of 26

### 11.1. Valve NDE & NDT Requirements

All valves shall be subject to NDE/NDT in accordance with ASME B16.34. Piping specification shall be followed for NDE requirement like Radiography (RT), Ultrasonic Testing/magnetic Particle Testing (MT), Dye Penetration Test etc.

### 11.2. PMI Requirements:

PMI shall be performed for alloy metal valves as per approved Positive Material Identification Procedure.

### 11.3. Sour and HIC service / NACE Requirements

In case of Sour and HIC service, the valve materials must meet the specific requirements hardness, radiography and other testing requirements, as per NACE MR-0103 latest edition.

### 11.4. Hydrogen Service Requirement

For valve used in Hydrogen Service, the valve must be certified for the use in Hydrogen service, specifically Hydrogen diffusion problems. Reference list, along-with performance feedback shall be furnished.

For hydrogen service the valve shall meet all the material and testing requirements such as Helium leak test etc.

### 11.5. Indian Boiler Regulation (IBR) Requirements

For applications involving Steam, the manufacturer must furnish the IBR form IIIC certification duly approved by IBR authority. All IBR approved drawings and certificates shall be submitted to owner through PMC.

### 11.6. PTR Requirement

Supplied valves shall be rugged in design and must be well proven in the hydrocarbon industry. Proto type design or equipment's of experimental nature or design undergoing testing etc. shall not be acceptable. Following criteria must be applied before selecting the valve.

The valve supplied should have been operating satisfactorily in a hydrocarbon industry like refinery, petrochemical and gas processing plant under similar process conditions for at least 8000 hours from the bid opening within duration of five years.

Contractor shall furnish reference list along-with with performance feedback in support of the above requirement.

### 11.7. Bolting and Gasket

Bolting and Gaskets shall conform to the following Specifications:

1. All bolts shall conform to ASME/ANSI B18.21, Nuts to be ASME/ANSI B18.22.
2. Stud bolts shall be threaded full length with two heavy hex nuts. Length tolerance shall be in

		<b>PROJECT</b>	<b>Standby SRU &amp; Additional Tanks</b>		
			<b>IOCL Paradip Refinery</b>		
		<b>CLIENT</b>	<b>INDIAN OIL CORPORATION LIMITED</b>		
<b>JOB SPECIFICATION FOR ON/OFF VALVES &amp; MOV</b>	<b>Project No.</b> 080557C001	<b>Document No.</b> 080557C-000-JSS-1543-001	<b>Rev. No.</b> D	Page 23 of 26	

- accordance with the requirement of table F2 of Annexure F of ASME B16.5.
3. Threads shall be to coarse Thread series, ANSI B1.1 having class 2A tolerance for Bolts and Studs and class 2B for nuts.
  4. The gasket used shall be of spiral wound type only with suitable filler material and conform to ANSI / ASME B 16.20. Compressed asbestos fibre (CAF) gaskets shall not be used.

## 12. NAMEPLATE

Each valve shall have a stainless-steel nameplate attached firmly to it at a visible place, furnishing the following information:

1. Tag number.
2. Body and port sizes in inches.
3. Max Valve body pressure rating
4. Max shut off pressure
5. Action on air failure.
6. Spring range.
7. Air supply pressure.
8. Electrical supply voltage, phase, frequency (for MOV)
9. Motor Type and rating (for MOV)
10. Manufacturer's name.
11. Manufacturers serial no. and model no. for Valve body, Actuator.

## 13. INSPECTION AND TESTING

- 1) Testing and inspection for all items shall be carried out as per approved factory testing procedures.
- 2) Unless otherwise specified, Owner/Consultant reserves the right to test and inspect all the items at the vendor's works, in line with inspection test plan for valves.
- 3) Vendor shall submit following test certificates and test reports:
  - a. Material test certificate as per clause 3.1 of EN 10204 for each valve body, bonnet castings/ forgings and as per clause 9.4 for trim.
  - b. Certificate of radiography/X-ray for valve castings. 100% radiography shall be carried out for the following valve castings as a minimum:
    - i. As per piping material specification.
    - ii. Body rating ANSI 600 pounds and above.
    - iii. Radiography procedure for casting shall be as per ANSI B16.34 and acceptance shall be as per ANSI B16.34 Annexure-B.
    - iv. Radiography procedure for welded parts shall be as per Piping Material Specifications / ASTM – ASME 31.3
  - c. Post-weld heat treatment shall be provided for welds, as per piping material specification.
  - d. Pneumatic test certificate for pneumatic actuator at a pressure not less 10 kg/cm<sup>2</sup>.

 <b>TechnipFMC</b>	 IndianOil	<b>PROJECT</b>	<b>Standby SRU &amp; Additional Tanks</b>		
			<b>IOCL Paradip Refinery</b>		
		<b>CLIENT</b>	<b>INDIAN OIL CORPORATION LIMITED</b>		
<b>JOB SPECIFICATION FOR ON/OFF VALVES &amp; MOV</b>	<b>Project No.</b> 080557C001	<b>Document No.</b> 080557C-000-JSS-1543-001	<b>Rev. No.</b> D	Page 24 of 26	

- e. IBR certificate in form III C for all valves covered under IBR certification. All IBR approved drawings and certificates shall be submitted to owner through PMC.
- f. Dimensional, hydrostatic test reports for all valve bodies and functional test reports for all valves as per clause 12.1 and 12.2 of this specification.
- g. Type test certificate for fire safety for fire safe valves and its actuator and controls.
- h. Certificate from statutory body for intrinsic safety/explosion proof for limit switches, solenoid valves etc. and type test certificate for weatherproof for these items.
- i. Following type test certificates of offered model of actuator (MOV) shall be submitted for review and approval
  - i. Life test.
  - ii. Test on motor terminal box.
  - iii. Damp heat recycling test.

### 13.1. Hydrostatic Test

Each valve body shall be subjected to hydrostatic test pressure equal to 1.5 times the maximum working pressure at ambient temperature in accordance with ANSI B16.34. All valve bodies covered under IBR, shall be tested as per IBR regulations. There shall not be any visible leakage during this test.

### 13.2. Functional Tests

Following tests shall be done as minimum as part of functionality check for On/Off valves and MOVs

1. Seat Leakage Test  
All valve shall be seat leak tested against standard API 598.
2. Tubing Leak Check  
Pneumatic tubes shall be bubble tested for leaks.
3. Stroke test  
Pneumatic actuated valves shall be stroke tested (full open to full close and vice versa) with minimum instrument air supply pressure and maximum DP across the valve. Open and close timing shall be recorded in test report.
4. MOV Actuator  
Functional and calibration test for torque and limit switches
  - Response time test
  - Variation of supply voltage
  - Variation of frequency
  - Test on output shaft at 100% torque
  - Tests for motor (As per relevant IS/IEC)

### 13.3. Witness Inspection

1. Pre-dispatch inspection for all valves shall be performed and following tests/checks shall be carried out as a minimum.

 <b>TechnipFMC</b>	 IndianOil	<b>PROJECT</b>	<b>Standby SRU &amp; Additional Tanks</b>		
			<b>IOCL Paradip Refinery</b>		
		<b>CLIENT</b>	<b>INDIAN OIL CORPORATION LIMITED</b>		
<b>JOB SPECIFICATION FOR ON/OFF VALVES &amp; MOV</b>	<b>Project No.</b> 080557C001	<b>Document No.</b> 080557C-000-JSS-1543-001	<b>Rev. No.</b> D	Page 25 of 26	

- a) Physical dimensional verification and workmanship.
- b) Hydrostatic test as per clause 12.1 of this specification on representative samples.
- c) Functional tests as per clause 12.2 of this specification on representative samples.
- d) Pneumatic test on actuator on representative samples.
- e) Review of all certificates and test reports as indicated in Section 12 point # 3 of this specification.

2. In the event when no witness inspection is carried out by Owner/Consultant, the tests shall anyway be completed by Contractor and documents for the same shall be submitted to Owner/Consultant for scrutiny.

#### **14. SPARES**

For Spare Philosophy for Instrumentation items, refer Mandatory spare part list attached in the ITB documents.

#### **15. SHIPPING**

1. It is the responsibility of the contractor to ensure that the equipment is adequately protected and packed to meet the shipping and delivery requirements. The equipment may be stored outdoor for long period before installation. Packing shall be suitable for outdoor storage in the area with heavy rains and high ambient temperature.
2. Machined surface which may be exposed to the atmosphere in the transit and subsequent storage shall be properly protected with an easily removable rust preventing coating of the proper consistency applied by the manufacturer, but not until inspection.
3. The valve and its accessories shall be supplied pre-assembled and pre-tubed.
4. All threaded and flanged openings shall be suitably protected to prevent entry of foreign material. Temporary plugs used should be readily distinguishable from permanent metal plugs.
5. Valves with external lubricators shall be lubricated prior to shipment.
6. Valves in oxygen and chlorine service shall be packed separately along with a certificate indicating 'CERTIFIED FOR OXYGEN / CHLORINE SERVICE', as applicable.

#### **16. DOCUMENTATION**

Following are the drawings and documents required to be submitted for the Valve, as a minimum:

1. Specification sheet for each valve and its accessories.
2. General Arrangement drawing for each valve providing the complete dimension of valve assembled with actuator and other accessories, weight of the valve assembly
3. Dimensions of clearance space required for maintenance work
4. Lifting Instruction for the valves.
5. Wiring diagram for the accessories like solenoid valve, limit switches including terminal numbers and cable type.
6. Wiring diagram for MOV actuator terminal compartment showing power supply, control signals and other contacts including spares with terminal numbers and cable type.
7. Copy of type test certificates.
8. Copy of the test certificates for all tests.
9. Installation procedure.

		PROJECT	Standby SRU & Additional Tanks		
		CLIENT	INDIAN OIL CORPORATION LIMITED		
JOB SPECIFICATION FOR ON/OFF VALVES & MOV	Project No. 080557C001	Document No. 080557C-000-JSS-1543-001	Rev. No. D	Page 26 of 26	

10. Calibration and maintenance procedure including replacement of its parts/internals wherever it is applicable.

All the documents shall be A4 or A3 size only; all the document prints larger than A4 shall be folded to A4 size with identification data visible at the bottom right.

All the documents submitted shall be checked & approved by Contractor, unchecked document will be returned un-reviewed & Contractor will be responsible for the delay.

Any revision to a document after its first submission shall be clearly identified on the documents in the revision box at the right bottom.

## 16. GUARANTEE AND WARRANTY

1. Contractor shall warranty the supply against defective materials, design and workmanship.
2. Contractor shall guarantee the performance of the valve at site, for the specified time specified elsewhere.
3. Equipment performance shall be guaranteed in accordance with requirements of applicable specifications and codes at conditions indicated in relevant specification.
4. If the stated performances are not achieved, Contractor shall, at his own expenses, make necessary repairs, modifications and replacements to the supply to enable the performance to be achieved.

### TYPICAL PARTIAL STROKE TESTING SCHEME

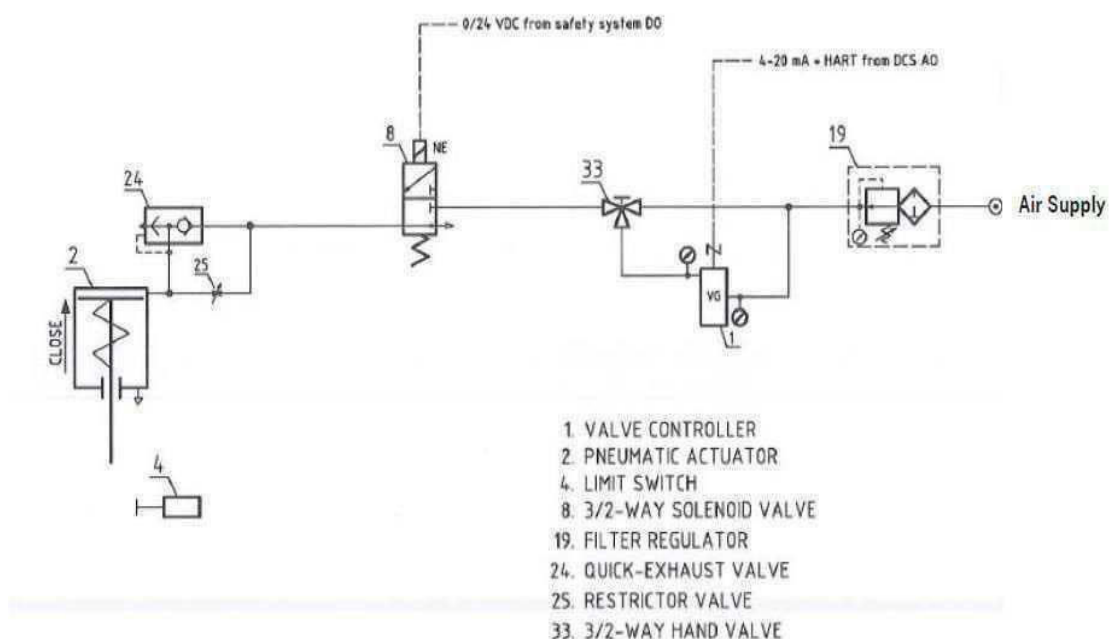

 	<b>PROJECT</b> <b>Standby SRU &amp; Additional Tanks</b> <b>IOCL Paradip Refinery</b>	<b>CLIENT</b> <b>INDIAN OIL CORPORATION LIMITED</b>		
	<b>CLIENT</b>			
<b>INSPECTION AND TEST PLAN FOR ON-OFF VALVES</b>	<b>Project No.</b> 080557C001	<b>Document No.</b> 080557-000-ITP-1543-001	<b>Rev. No.</b> B	Page 1 of 5

11.10.2019

## INSPECTION AND TEST PLAN FOR ON-OFF VALVES

### INSPECTION CATEGORY: 3

REV.	DATE	DESCRIPTION	PREPARED	CHECKED	APPROVED	AUTHORIZED
B	10.12.2019	ISSUED FOR QUOTATION	SGR	GM	SS	JMC
A	11.10.2019	ISSUED FOR QUOTATION	SGR	GM	SS	JMC

This document is developed by TECHNIP India Limited and the information it contains is property of Indian Oil Corporation Ltd. It shall not be used for any purpose other than that for which it is supplied.

CONFIDENTIAL – Not to disclose without Authorization

		<b>PROJECT</b>	<b>Standby SRU &amp; Additional Tanks</b>		
		<b>CLIENT</b>	<b>IOCL Paradip Refinery</b>		
<b>INSPECTION AND TEST PLAN FOR ON-OFF VALVES</b>	<b>Project No.</b> 080557C001	<b>Document No.</b> 080557C-000-ITP-1543-001	<b>Rev. No.</b> B	Page 2 of 5	

## 1. SCOPE

This Inspection and Test Plan is an engineering document which defines for each type of equipment:

- the type and extent of VENDOR/CONTRACTOR and OWNER / PMC involvement in each phase of fabrication, control and testing requiring an inspection or a documentation review
- the resulting VENDOR's/CONTRACTOR's contractual obligations, in accordance with applicable Project General Purchase Conditions.



**Note:** The Inspection and Test Plan may under no circumstances be used as a substitute to the VENDOR's/CONTRACTOR's Fabrication and Quality Control Plan.

## 2. GENERAL DEFINITIONS

<b>Abbreviation</b>	<b>Definition /Expanded form</b>
IOCL/ CLIENT	Indian Oil Corporation Limited
PMC/ CONSULTANT	Technip India Limited
LICENSOR	Party selected by IOCL for process technology ownership for any UNIT
CONTRACTOR	Party whose services are obtained for performing the works specified as part of LSTK / packages.
EPCM	Engineering, Procurement & Construction Management Services.
LSTK	Lump Sum Turn Key portion of the work to be executed by CONTRACTOR
FEED	Front End Engineering Design
AUTHORISED REPRESENTATIVE	IOCL's/ CONSULTANT's representative authorized to act for and on behalf of them.
VENDOR	Any third party supplying the equipment/materials for setting up the Plant
PROJECT	Indicates Standby SRU and Additional tanks Project, Paradip Refinery
UNIT	Indicates any particular portion of the project to be built which can be Process related or Utilities/Offsites related
SRU	Sulphur Recovery Unit

This document is developed by TECHNIP India Limited and the information it contains is property of Indian Oil Corporation Ltd. It shall not be used for any purpose other than that for which it is supplied.

CONFIDENTIAL – Not to disclose without Authorization

 	<b>PROJECT</b> <b>Standby SRU &amp; Additional Tanks</b> <b>IOCL Paradip Refinery</b>			
	<b>CLIENT</b> <b>INDIAN OIL CORPORATION LIMITED</b>			
<b>INSPECTION AND TEST PLAN FOR ON-OFF VALVES</b>	<b>Project No.</b> 080557C001	<b>Document No.</b> 080557C-000-ITP-1543-001	<b>Rev. No.</b> B	Page 3 of 5

Extent of Inspection: The extent of Inspection activities is defined as follows:

- H (Hold Point): Mandatory witness of testing or inspection activities by CONTRACTOR /OWNER/CONSULTANT. The VENDOR shall notify at least 2 Weeks (10 Working days) in advance and CONTRACTOR /OWNER/CONSULTANT must be present during the specified activity. The VENDOR cannot deviate from this rule unless written approval has been given by the CONTRACTOR /OWNER/CONSULTANT.
- W (Witness): Optional witness of testing or inspection activities by the CONTRACTOR /OWNER/CONSULTANT. The VENDOR must notify at least 2 Weeks (10 Working days) in advance. If CONTRACTOR /OWNER/CONSULTANT does not elect to be present, the VENDOR may proceed with the intended activity, provided controls and test reports are made available for the inspector's review during his subsequent visit.
- R (Review): Review and acceptance of documentation such as reports, procedures and qualification records. Other applicable documents will be reviewed by the CONTRACTOR /OWNER/CONSULTANT.

### 3. CATEGORY OF INSPECTION

Inspection activities shall be based on hold/witness/review points specified in the Inspection & Test Plan (ITP) and confirmed at the Pre-Inspection Meeting. CONTRACTOR / PMC / OWNER Inspection will be based on critical ratings and corresponding levels of inspection.

Category of inspection are defined as follows:

**Category 1:** Stage wise and final inspection including monitoring of critical phases of fabrication performed at main supplier and main sub-supplier and Documents review as per ITP by CONTRACTOR / TPIA & Witness of Critical Stage / Test / Final inspections by OWNER wherever felt necessary.

**Category 2:** Stage wise and final inspection and Documents review as per ITP by CONTRACTOR / TPIA witness of final inspection, by OWNER, if felt necessary.

**Category 3:** Final inspection and Documents review as per ITP by CONTRACTOR / TPIA.

**Category 4:** Documents Review as per ITP by CONTRACTOR / TPIA.



### 4. PRE-INSPECTION MEETING

A Pre-Inspection meeting to be held at VENDOR's Works is a review with VENDOR by CONTRACTOR, prior to the start of manufacturing, to ensure understanding of purchase order requirements, including project specifications, applicable codes/standards and all inspection requirements.

### 5. VENDOR 'S FABRICATION AND QUALITY CONTROL PLAN (FQCP)

The VENDOR shall issue Fabrication and Quality Control Plan for each equipment. The VENDOR's Fabrication and Quality Control Plan is a document, which defines in a

This document is developed by TECHNIP India Limited and the information it contains is property of Indian Oil Corporation Ltd. It shall not be used for any purpose other than that for which it is supplied.

		<b>PROJECT</b>	<b>Standby SRU &amp; Additional Tanks</b>		
		<b>CLIENT</b>	<b>INDIAN OIL CORPORATION LIMITED</b>		
<b>INSPECTION AND TEST PLAN FOR ON-OFF VALVES</b>	<b>Project No.</b> 080557C001	<b>Document No.</b> 080557C-000-ITP-1543-001	<b>Rev. No.</b> B	Page 4 of 5	

chronological manner, the list of the operations of fabrication, controls and tests in accordance with his own "know-how" and with the requirements specified in the project specifications attached with the Inquiry document and/or relevant codes & standards.

Following information shall be clearly specified against each operation:

- Reference documents (drawings, procedures, etc.)
- Acceptance criteria (code, etc.)
- Recording documents for controls and tests
- Involvement of the Quality Control department of the VENDOR and/or his Sub-VENDOR
- Involvement of VENDOR/ CONTRACTOR / PMC / OWNER

## 6. RIGHT TO INSPECT

All Equipment shall be subject to inspection by OWNER/ PMC. The Inspector shall have free access to the VENDOR's shop/work site. The VENDOR shall provide all facilities like tools and tackles, instruments and personnel to the inspector and CONTRACTOR shall arrange for such INSPECTION on request from OWNER / PMC.

The CONTRACTOR/OWNER/CONSULTANT shall be entitled to reject at any time any portion of the Equipment which is defective, deficient, not within specifications or otherwise of inferior quality or faulty workmanship and require its re-performance or replacement. Rejected and other defective or deficient workmanship shall be satisfactorily redone. The costs associated with such re-performance or replacements shall be for the account of the VENDOR. After completion of the necessary re-performance or replacements, the Equipment shall be subject to further Inspection and examination by CONTRACTOR/OWNER/CONSULTANT. Applicable repair procedure and VENDOR's repair recommendations shall be submitted to the Inspector for approval. No repair shall be made without the Inspector's acceptance.

## 7. INSPECTION RELEASE CERTIFICATE

This document will be issued by CONTRACTOR / TPIA permits the VENDOR/ CONTRACTOR to proceed with the packing and to notify the shipment of the Equipment.

**INSPECTION AND TEST PLAN (ITP)**

- THE «ITP» IS A GUIDELINE DEFINING THE EXTENT OF CONTRACTOR AND OWNER/OWNER REPRESENTATIVE FOR ALL INSPECTION LEVELS  
- TYPE AND EXTENT OF TESTS SHALL COMPLY WITH CODES AND/OR ORDER SPECIFICATIONS

CLASS:		TYPE:				
INSTRUMENTS		ON-OFF VALVES				
STAGE	ACTIVITIES DESCRIPTION	Vendor	Contractor / TPIA	PMC	Owner	APPLICABLE DOCUMENTS AND REMARKS
BEFORE FABRICATION	Pre-Inspection Meeting	H	H	R		
	Suborders check	H	H			For main materials and/or activities complete with all the technical attachments.
	WPS/PQR/WPQ for all welding	H	H			As per ASME Sec IX
	Statutory approval certificates	R	R			Issued by Recognized Authority
	N.D.E on Raw materials (RT/PT/MT/UT etc.,)	H	H			
	Mechanical Protection Degree Certificate	R	R			At least Conformity Certificate
	Material test certificates	H	R			Type EN 10204-3.1 for all pressure parts At least Compliance Certificate for others components, Chemical and Mechanical properties, NACE requirement, if applicable.
IBR Requirement, if applicable	H	H			IBR form IIIC approved, tested and certified by IBR	
DURING FABRICATION	N.D.E of weld (RT/PT/MT/UT etc.,)	H	R			
	Seat Leakage test	H	R			API-598 as per valve data sheet
	Hydro Test on Body	H	R			As per ASME B16.34
	Pneumatic Test for Pneumatic actuator	H	R			For actuator at max design pressure
	Operation checks Characteristic test	H	R			For limitswitch, local display unit, etc
FINAL TEST	Visual / Dimensional check	H	W	R		To check conformity with technical data and approved drawings
	Checking of Main characteristics	H	W	R		To check compliance of Valve Components with relevant data sheet
	Hydro Test on Body	H	W	R		
	Pneumatic Test for Pneumatic actuator	H	H	R		For valve actuator
	Seat Leakage and actuators Leak Test	H	W	R		Spot witnessed 10% for each inspection lot. Pressure value applicable acc. to required seat leakage class as per individual datasheet.
	Low emission test (if specified)	H	H	R		Review of Declaration of Conformity to Applicable Codes/Standards
	Helium Leak test (if specified)	H	H	R		For H2 service
	Performance Test and functional checks	H	W	R		Stoke test, Open-close time of valve against full shut-off pressure.
	Positive Material Identification, if applicable	H	H	R		
	Review of test certificates and Operational checks for All bought outs / accessories	H	R/W	R		Review of test certificates for bought outs/accessories (AFR, Solenoid, limit switches and actuators)
	Verification of bought out spare lists and the Mfg. test Certificates checks	H	R	R		
	Lift Characteristic test	H	H	R		
Surface preparation /Painting check	H	H	R			
Labelling check	H	R	R			
Packing check	H	R	R			
DOCUMENTATION	Manufacturer's Data/Record Book (MDRB)	H	R	R		

This document is developed by TECHNIP India Limited and the information it contains is property of Indian Oil Corporation Ltd. It shall not be used for any purpose other than that for which it is supplied.  
CONFIDENTIAL – Not to disclose without Authorization

**PTR Format  
(FOR ON OFF BALL/ BUTTERFLY/ PLUG VALVES)**

SL. NO.	DESCRIPTION	AS OFFERED FOR THIS PROJECT	SYSTEM AS INSTALLED @ SITE 1	SYSTEM AS INSTALLED @ SITE 2	SYSTEM AS INSTALLED @ SITE 3	SYSTEM AS INSTALLED @ SITE 4
1	Name of Plant					
2	Name, Address, E-Mail, Tel. No. of contact person in plant					
3	Name, Address, E-Mail & Telephone No. of consultant					
4	Month & year of supply					
5	Month & year of commissioning					
6	Any major breakdown till date					
7	<p><b><u>Size for On Off Plug Fully Jacketed Valves:</u></b></p> <p>a) 12"x10", 300#  b) 10"x8", 300#  c) 8"x6", 300#</p>					

**Bidder Seal & Signature**



PROJECT ENGINEERING AND SYSTEMS DIVISION  
BHARAT HEAVY ELECTRICALS LIMITED  
R.C.PURAM HYDERABAD – 500032

Document: Annex. 02 of PY-AS-4-M170-8564-11

Rev No: 00

Date : <To be filled by Bidder>

**FORMAT FOR CHECKLIST ON TECHNICAL AND JOB SPECIFICATIONS**

**Project** : IOCL PARADIP SULPHUR RECOVERY UNIT  
**Enquiry No. with date** :  
**Description of Items** :  
**Bidder** :

Sl.No.	Description	Enclosed (Yes/No) (To be filled by Bidder)
	This format is only to ensure that bidder has understood the requirement :-	Yes
1.	Confirmation that Proven Track Record is submitted along with the offer as per clause 11.6 of Job specification for On Off valve & MOV (DOC No: 080557C-000-JSS-1543-001).	Yes
2.	Confirmation that Deviations (if any) are submitted along with the offer in specified format only (i.e. in Annexure-3). If No deviation is there then NIL to be mentioned and submitted.	Yes
3.	In case of deviation, vendor to confirm that these are technically not feasible deviations and same are submitted in BHEL format. In case technically feasible deviations are proposed by the bidder and subsequently withdrawn, no commercial implications can be claimed by the bidder	Yes
4.	Confirmation that signed copies of the following are submitted along with the offer. Filled in Datasheet in format issued with Material Requisition PTR references in format issued with Material Requisition Unpriced Price Bid Format Deviation Schedule Signed copy of BHEL QAP attached along with Enquiry document.	Yes
5.	Confirmation that <b>Commissioning spares</b> are quoted in the offer as per Purchaser's price bid format attached as "Annexure-1 to PY-AS-4-M170-8564-11".	Yes
6.	Confirmation that <b>Mandatory spares</b> are quoted in the offer as per Purchaser's price bid format attached as "Annexure-1 to PY-AS-4-M170-8564-11".	Yes
7.	Bidder to confirm that the separate list of Mandatory spares along with the applicable tag nos. will be submitted after placement of Order for approval of Purchaser.	Yes

8.	Confirmation that “ <b>Un-priced price bid format</b> ” is submitted, clearly indicating all the applicable items as “Quoted” and highlighting the not applicable items.	Yes
9.	Bidder to note that the Inspection & Testing requirements shall be as per BHEL’s enquiry documents. QAP for the package will be reviewed by BHEL only during detail engineering stage after PO (not during pre-PO phase),	Yes
10.	Makes of all the accessories are of “List of Sub-Vendor Items“ only (Annexure-5)	Yes



PROJECT ENGINEERING AND SYSTEMS DIVISION  
BHARAT HEAVY ELECTRICALS LIMITED  
R.C.PURAM HYDERABAD – 502 032

**Document:** Annex. 03 of PY-AS-4-M170-8564-11

**Rev No:** 00

**Date :** <To be filled by Bidder>

**FORMAT FOR DEVIATIONS ON TECHNICAL AND JOB SPECIFICATIONS**

**Project** : IOCL PARADIP SULPHUR RECOVERY UNIT  
**Enquiry No. with date** :  
**Description of Items** :  
**Bidder** :

Sl. No	Reference			BHEL Specification's Requirement	Deviation taken by Bidder
	Doc. No.	Page No.	Clause No.		
( To be filled by the bidder)					

Turn Overleaf.

	PROJECT ENGINEERING AND SYSTEMS DIVISION BHARAT HEAVY ELECTRICALS LIMITED R.C.PURAM HYDERABAD – 502 032	<b>Document:</b> Annex. 03 of PY-AS-4-M170-8564-11
		<b>Rev No:</b> 00
		<b>Date :</b> <To be filled by Bidder>

**1. INSTRUTIONS TO THE BIDDERS.**

- i. Technical offer of the bidder will be evaluated only on the basis of Deviation Schedule. Deviation Schedule constitutes this sheet (with these Notes) duly signed and stamped.
- ii. Deviations, if any, shall be clearly brought out only in this format. Deviations mentioned / taken elsewhere or in any other format will be summarily rejected and shall be ignored.
- iii. Nature of Deviations shall only be of Design / Manufacturing constraints and non-availability of items / components / makes in market.
- iv. **No price implications** shall be entertained **for deviations withdrawn** during the technical scrutiny. **If any deviations are accepted by BHEL during technical scrutiny then also there will be no price implication. Hence, in no case there will be consideration of Price implications.**
- v. **If there are no deviations from the specifications, bidder still has to submit the signed copy of this format by writing “NO Deviations” on this format.**
- vi. If the “Deviation Schedule” is not submitted along with the offer, the bidder’s offer is likely to be rejected without any further interaction with the bidder. Only the accepted deviations in conjunction with the original tender shall constitute the contract document for the award of job to the bidder.
- vii. Additional sheets, if necessary for bidder’s deviations, may be enclosed.

**2. BIDDER’S DECLARATION.**

- i. We confirm that all our deviations to BHEL’s specifications and its annexures are listed in this document only.
- ii. We confirm that except for those deviations, covered in this document, it will be our responsibility to fully meet the intent and the requirements of the specifications and all its annexures within the quoted price, without any deviation.

Bidder’s Signature.....  
 Name: .....  
 Date: .....  
 Company’s Name.....  
 Company’s Seal.....



PROJECT ENGINEERING AND SYSTEMS DIVISION  
BHARAT HEAVY ELECTRICALS LIMITED  
R.C.PURAM HYDERABAD – 502 032

**Document:** Annex. 04 of PY-AS-4-M170-8564-11

**Rev No:** 00

**Date :** <To be filled by Bidder>

**FORMAT FOR PRE-BID QUERIES ON TECHNICAL AND JOB SPECIFICATIONS**

**Project** : IOCL PARADIP SULPHUR RECOVERY UNIT  
**Enquiry No. with date** :  
**Description of Items** :  
**Bidder** :

Sl. No	Reference			BHEL Specification's Requirement	Bidder's Query / Observation	BHEL's Clarifications.
	Doc. No.	Page No.	Clause No.			
( To be filled by the bidder)						( To be filled by BHEL)

Turn Overleaf.

	<p>PROJECT ENGINEERING AND SYSTEMS DIVISION          BHARAT HEAVY ELECTRICALS LIMITED          R.C.PURAM HYDERABAD – 502 032</p>	<p><b>Document:</b> Annex. 04 of PY-AS-4-M170-8564-11</p> <p><b>Rev No:</b> 00</p> <p><b>Date :</b> &lt;To be filled by Bidder&gt;</p>
---	--	--

**1. INSTRUCTIONS TO THE BIDDERS.**

- i. All of bidder’s queries / clarifications / observations to the BHEL specification shall be intimated to BHEL in a consolidated manner in this document only.
- ii. BHEL will clarify in writing to the bidder all such queries / clarifications / observations raised by the bidder( including the acceptance / non acceptance of the deviations from specification)
- iii. Decision of BHEL on all such queries / clarifications / observations raised by bidder will be final and binding on bidder.
- iv. In case no pre-bid query is raised by bidder, it will be assumed that the bidder has accepted and confirmed to all the requirements of BHEL’s specification in totally without any deviation.**
- v. None of the bidder’s queries / clarifications / observations (except those that have been specifically mentioned in this document and have been accepted by BHEL during the pre-bid stage) will be accepted or allowed during post bid stage / offer execution stage.
- vi. Additional sheets, if necessary for bidder’s queries / clarifications / observations, may be enclosed.

**2. BIDDER’S DECLARATION.**

- i. We confirm that all our queries / clarifications / observations to the BHEL’s Specifications and its annexures are listed in this document only.
- ii. We confirm that except for those queries / clarifications / observations covered in this document, it will be our responsibility to fully meet the intent and the requirements of the specifications and all its annexures within the quoted price, without any deviation.

Bidder’s Signature.....

Name: .....

Date: .....

Company’s Name.....

Company’s Seal.....

## Annexure-5 to PY-AS-4-M170-8564-11

### Sub Vendor list for the P. on off Valve Package:-

The following the list of Sub-Vendor to be followed for the subject enquiry:-

- AIR Filter Regulators:
  - CLARK-RELIANCE CORPORATION\*
  - DONALDSON (INDIA)\*
  - DONALDSON FILTRATION (THAILAND. LTD)\*
  - EKOPLANT\*
  - MARSH BELLOFRAM\*
  - MIKROPUL AUSTRALIA PTY LTD\*
  - PALL\*
  - PARKER FILTRATION CANADA INC.\*
  - PARKER HANNIFIN CORPORATION\*
  - PLACKA INSTRUMENTS INDIA P LTD
  - SCHRADER DUNCAN LIMITED\*
  - SHAVO NORGREN (I) PVT LTD
  
- JUNCTION BOXES (Weather Proof):- (BHEL PMD No. : PE.IN.537)
  - FLAMEPROOF EQUIPMENT Pvt. Ltd.
  - FCG FLAMEPROOF CONTROL GEARS
  - PANAM CONTROLS
  - PYROTECH ELECTRONICS PVT. LIMITED
  - FLEXPRO CHEMICALS PVT. LIMITED.
  - EX-PROTECTA
  
- JUNCTION BOXES (Ex-proof):- (BHEL PMD No. : PE.IN.538)
  - BAJAJ LIGHTING EQUIPMENTS (P) LIMITED\*
  - COOPER CROUSE-HINDS\*
  - FCG FIAMPROOF CONTROL GEARS P. LTD
  - FCG POWER INDUSTRIES PVT LTD
  - FLAMEPROOF EQUIPMENTS PVT LTD.
  - FLEXPRO ELECTRICALS PVT LTD
  - GOVAN INDUSTRIES INDIA PVT LTD\*
  - KAYSONS TECHNO EQUIPMENT P LTD.\*
  - PETROLEUM SAFETY PRODUCTS IND. PVT. LTD.\*
  - PROMPT ENGINEERING WORKS\*
  - R STAHL PVT LTD.\*
  - SUDHIR SWITCHGEARS PVT LTD\*
  
- PRESSURE GUAGES :- (BHEL PMD No. : PE.IN.552)
  - AN INSTRUMENTS PVT LTD
  - BADOTHERM PROCESS INSTRUMENTS B.V/BADOTHERM FAR EAST CO. LTD\*
  - BAUMER BOURDEN HAENNI SAS\*
  - BAUMER TECHNOLOGIES INDIA PVT LTD
  - BUDENBERG GAUGE CO. LTD\*
  - GAUGES BOURDEN (i) PVT LTD. ( GEN. INST)

- GOA INSTRUMENTS INDUSTRIES PVT LTD\*
- H GURU INSTRUMENTS ( SOUTH INDIA) PVT LTD
- H GURU INDUSTRIES\*
- MANOMETER ( INDIA) PVT LTD\*
- MASS PRODUCTS PVT LTD\*
- PRECISION MASS PRODUCTS PVT LTD OLD NAME ASHCROFT INDIA PVT LTD
- WALCHANDNAGAR INDUSTRIES LTD ( TIWAC DIVN)\*
- WIKA ALEXANDER WIEGAND & CO GMBH\*

*(However, if pressure gauge is built-in along with AFR or Positioner, then its make can either be as that of main item (AFR or Positioner) or as per the above list.)*

- Limit Switches (PROXIMITY)
  - P&F
  - MTL
- Solenoid Valves
  - ALCON ALEXANDER CONTROLS LIMITED\*
  - ASCO JOUCOMATIC LTD\*
  - ASCO NUMATICS (INDIA) P. LIMITED
  - AVCON CONTROLS PVT. LTD\*
  - HERION WERKE
  - PRECISION INSTRUMENT COMPANY\*
  - RMEBS CONTROLS PVT LTD
  - SCHRADER DUNCAN LIMITED\*
  - THOMPSON VALVES LTD\*
  - VERSA BV\*
- SMART Positioners
  - DRESSER
  - FISHER (EMERSON)
  - FLOWSERVE INDIA CONTROL PVT LTD- BANGALORE\*
  - METSO AUTOMATION
  - SAMSON CONTROLS PVT LTD\*
- Cable Glands (WEATHERPROOF/EXPROOF) (BHEL PMD No. : PE.EP.038)
  - FLEXPLO ELECTRICALS PVT. LTD.,
  - FCG POWER INDUSTRIES
  - PROMPT ENGINEERING WORKS, MUMBAI
  - FCG FLAMEPROOF CONTROL GEARS
  - FLAMEPROOF EQUIPMENTS PVT.LTD.
  - ELECTROMAC INDUSTRIES
  - UNITED AGRO ENGINEERING PVT. LIMITED
- Pneumatic tubing & fittings
  - ARYA CRAFTS & ENGINEERING PVT LTD\*
  - ASTEC VALVES & FITTINGS PVT. LTD.\*
  - AUTOCLAVE ENOINERS FLUID COMPONENTS\*
  - CIRCOR INSTR. TECHNOLOGIES INC-\*

- COMFIT SS VALVES PVT. LTD.\*
  - EXCEL HYDRO PNEUMATICS PVT LTD\*
  - EXCELSIOR ENGG. WORKS\*
  - FLUID CONTROLS PVT LTD\*
  - MULTIMETAL INDUSTRIES\*
  - PANAM ENGINEERS\*
  - PARKER HANNIFIN CORPORATION
  - PRECISION ENGINEERING INDUSTRIES\*
  - PRIME ENGINEERS\*
  - RELIANCE ENGINEERING & ELECTRICALS CORPN\*
  - SEALEXCEL INDIA PVT. LTD.\*
  - SSP FITTINGS CORPORATION\*
  - SWAGELOK CO. CO.
  - SWASTIK ENGINEERING WORKS\*
  - TK FUJBON CORPORATION\*
  - FITOK INCORPORATED\*
  - WESMEC ENGINEERING PVT. LTD\*
- Pneumatic Actuator (Own make actuators are preferred; In case bidders are out-sourcing actuators, following list to be followed)
    - ROTEX
    - ELOMATIC
    - BIFFI
    - BETTIS
    - ROTORK
    - NELES INDIA

\* - If bidder offers this make marked with '\*', bidder shall submit PTR References list along with the technical offer for review & confirmation by PURCHASER. Also bidder to furnish any further clarifications/ confirmations in this regard, as requested by BHEL during the evaluation of offer and post-order stage. Purchase holds the right to accept or reject this make based on the credentials submitted by the bidder.

**Annexure-7 to PY-AS-4-M170-8564-11, Rev 00**

**"MASTER DOCUMENT LIST FOR PNEUMATIC ON-OFF ECCENTRIC/ROTARY PLUG VALVES"**

Sl .no	Drawing/Document Number	Vendor Drawing number (if applicable)	Drawing Name	Category(Approval/Info)	Reqd for Mfg(Y/N)	Plan sub date	Actual Submission date	BHEL Comments Date & Code
1	PY-VD-4-M170-8564-11-01	VDR-1	Datasheets of Pneumatic On/Off valves	Approval	Y	2 WEEKS AFTER PO		
2	PY-VD-4-M170-8564-11-02	VDR-2	General arrangement drawings of Pneumatic On/Off valves	Approval	Y	2 WEEKS AFTER PO		
3	PY-VD-4-M170-8564-11-03	VDR-3	Actuator sizing calculations	Information	N	2 WEEKS AFTER PO		
4	PY-VD-4-M170-8564-11-04	VDR-4	Pneumatic hook-up diagram	Information	N	3 WEEKS AFTER PO		
5	PY-VD-4-M170-8564-11-05	VDR-5	Technical Catalogue of Sub vendor items	Information	Y	3 WEEKS AFTER PO		
6	PY-VD-4-M170-8564-11-06	VDR-6	Instrument air consumption details	Information	N	3 WEEKS AFTER PO		
7	PY-VD-4-M170-8564-11-07	VDR-7	List of Mandatory spares	Approval	Y	3 WEEKS AFTER PO		
8	PY-VD-4-M170-8564-11-08	VDR-8	List of commissioning spares	Approval	Y	3 WEEKS AFTER PO		
9	PY-VD-4-M170-8564-11-09	VDR-9	Painting procedure	Approval	Y	4 WEEKS AFTER PO		
10	PY-VD-4-M170-8564-11-10	VDR-10	O&M Manuals	Approval	Y	6 WEEKS AFTER PO		
11	PY-VD-4-M170-8564-11-11	VDR-11	Wiring diagram	Approval	Y	3 WEEKS AFTER PO		
12	PY-VD-4-M170-8564-11-12	VDR-12	CCOE/PESO Approval Certificates	Information	N	6 WEEKS AFTER PO		
12	PY-VD-4-M170-8564-11-13	VDR-13	SIL certificates of SOV and Limit Switch	Information	N	6 WEEKS AFTER PO		

**Notes:**

- 1 Bidder to furnish the documents as per the schedule date of submission. Delay in submission of documents shall be calculated based on the above schedule.
- 2 All drawings / documents shall be reviewed by the purchaser within 15 working days of receipt of drawing at Purchaser's end.
- 3 All drawings / documents shall be revised and resubmitted by the Bidder with 7 working days of receipt of observations/comments from Purchaser's end.



**PROJECT ENGINEERING & SYSTEMS DIVISION  
RC PURAM, HYDERABAD.  
QUALITY & BUSINESS EXCELLENCE**

**INSPECTION / TC REVIEW FORMAT**

1	Vendor's Name:		5	Applicable BHEL Spec No:	
2	Project:		6	Approved Drawing No:	
3	PO No:		7	Approved Data Sheet No:	
4	Item Description:		8	Approved QAP No:	

**OFFER LIST**

S.No	BBU/ PO Sr. No.	Item Description	Total Qty as per PO/BBU	Qty. already accepted	Qty offered for TC review	Cumulative Qty	Balance Qty
A							
B							
C							
D							

**TC REVIEW REQUISITION**

BBU / PO Sr. No.	QAP Clause No.	Format of Record	Certificate No. & Date	Page No.	REMARKS
<b>A. Item Description:</b>					
<b>B. Item Description:</b>					
<b>C. Item Description:</b>					
<b>D. Item Description:</b>					
<b>E. Item Description:</b>					

**SUPPLIER / VENDOR SIGNATURE WITH SEAL**

**BHEL/ BHEL's TPIA SIGNATURE WITH SEAL**

**Dt:**

**Dt:**



## QAP GUIDELINES & FORMAT

(ANNEXURE)

The QAP format and guidelines for filling up the format shall be used by vendor for preparation and submission of QAP after order placement.

**Note:**

1. Typical /Indicative /Standard QAP(s) for equipment /package attached is reference document and to use by successful bidder in future for preparation and submission of QAP for BHEL /CUSTOMER approval.
2. No deviation to reference document is acceptable.

**COPYRIGHT AND CONFIDENTIAL**

The information on this document is the property of BHARAT HEAVY ELECTRICALS LIMITED, It must not be used directly or indirectly in any way detrimental to the interest of the company.

Form No.	 <b>HYDERABAD</b>	<b>PRODUCT STANDARD</b> PROJECT ENGINEERING & SYSTEMS DIVISION HYDERABAD	ANNEXURE Rev No. 00 Page 2 of 4
<b>COPYRIGHT AND CONFIDENTIAL</b> The information on this document is the property of BHARAT HEAVY ELECTRICALS LIMITED . It must not be used directly or indirectly in any way detrimental to the interest of the company.	<b><u>GUIDELINES TO VENDORS FOR          PREPARATION OF QUALITY ASSURANCE PLAN</u></b>		
Ref. Doc	<ol style="list-style-type: none"> <li>1. QAP shall be made in landscape mode on A4 size paper as per the format enclosed. Font size shall be minimum 10.</li> <li>2. Each page of QAP shall contain the following information.             <ol style="list-style-type: none"> <li>a) Vendor's name &amp; address.</li> <li>b) Customer: BHEL, Hyderabad.</li> <li>c) Project.</li> <li>d) BHEL Product Standard Number/revision number as referred in P.O.</li> <li>e) BHEL Purchase Order Number &amp; Date.</li> <li>f) Product as per P.O. description.</li> <li>g) QAP Number (unique and shall not repeat)/revision number/date.</li> <li>h) Page number and number of pages</li> </ol> </li> <li>3. QAP shall contain four parts / stages as follows.             <ol style="list-style-type: none"> <li>a) Raw materials and bought out items.</li> <li>b) In process Control / Inspection.</li> <li>c) Final assembly, Inspection &amp; Testing.</li> <li>d) Painting, preservation &amp; packing.</li> </ol> </li> <li>4. Under 'Component', indicate name of the component (say casing, rotor, pressure gauge, etc).</li> <li>5. Under 'Characteristics', indicate appropriately (say chemical analysis, mechanical properties, NDT (UT, DP etc.), hydrostatic test, calibration check etc.)</li> <li>6. Under 'Class', indicate minor, major or critical depending on the importance of characteristic.</li> <li>7. Under 'Type of check', indicate appropriately (say chemical, mechanical, UT, DP etc.)</li> <li>8. Under 'Quantum of check', indicate appropriately (say 100%, 10%, sample, per melt, per heat, all pieces etc.)</li> <li>9. Under 'Reference document' and 'Acceptance norms', appropriate National &amp; International standards, BHEL standards, approved drawing references etc. should be indicated. It is not correct to mention as "Vendor's internal standards or Vendor's standard practice etc.". If vendors' internal standards are referred, same shall be in line with BHEL Spec. indicated in the P.O. These may require review &amp; approval by our Engineering dept.</li> <li>10. Under 'Format of record', indicate appropriately supplier's test certificate, calibration certificate, lab report, inspection report etc.</li> <li>11. Please refer 'Agency' in QAP format.              Under P: Perform, W: Witness, V: Verify              Indicate against each characteristic 1: (BHEL CQS/Nominated inspection agency), OR              2: (Vendor / Sub vendor)           </li> </ol>		

Form No.	 <b>HYDERABAD</b>	<b>PRODUCT STANDARD</b> <b>PROJECT ENGINEERING &amp; SYSTEMS DIVISION</b> <b>HYDERABAD</b>	<b>ANNEXURE</b> Rev No. 00 Page 3 of 4
<b>COPYRIGHT AND CONFIDENTIAL</b> The information on this document is the property of BHARAT HEAVY ELECTRICALS LIMITED . It must not be used directly or indirectly in any way detrimental to the interest of the company.	<p>Note: Performing agency is normally vendor or his sub vendor (Legend 2). Where witness points are indicated in specification, P.O., Drawing etc., for such operations, Under Witness (W) column use 1. Under 'Verify' column, use code1.</p> <p>12. Under 'D' please put (☐ Tick) against each characteristic where vendor proposes to submit test certificate/report etc. OR as required as per BHEL Specification.</p> <p>13. Vendor's signature &amp; stamp should be available on each page of QAP.</p> <p>14. Vendor should read the BHEL Product Standard thoroughly and QAP should be made only inline and relevant to the Specification &amp; Approved Drawings.</p> <p>15. The following operations/characteristics/check points may be included (AS APPROPRIATE)</p> <ol style="list-style-type: none"> <li>a) Visual check</li> <li>b) Dimensional check</li> <li>c) Mechanical and Chemical properties.</li> <li>d) Surface preparation before painting (by chemical cleaning, sand blasting, shot blasting etc. as the case may be.)</li> <li>e) Painting check for shade, Dry Film Thickness (DFT), Adhesion/ peel off test etc.</li> <li>f) Check for correctness for all components mounted as per General Arrangement Drawing, Bill of Materials (BOM), etc. for range, rating, make, color, size, location as per GA, quantity, label description including tag nos., annunciator facia, loose components, accessories, spares etc.</li> <li>g) Verification of test certificate for protection class for the enclosures.</li> <li>h) Mechanical functioning of switches.</li> <li>i) Continuity of earthing and provision of earth points.</li> <li>j) Colour coding of wiring, size, tightness &amp; dressing of wiring.</li> <li>k) Review of test certificates of assembled items, raw materials, internal test reports etc.</li> <li>l) Witness of functional checks, which may include mechanical run &amp; electrical run, H.V.test, IR measurement, Electrical and Mechanical tests etc.</li> <li>m) PQR, WPS, Welder Qualification Record, welding records (fit up, DP) etc.</li> <li>n) Material identification (for punch marks of serial numbers, Heat No, Melt No, Inspector's stamp etc.)</li> <li>o) Hydraulic Pressure Test, Pneumatic Pressure Test, Liquid Penetration Examination and other Non-Destructive Tests.</li> <li>p) Tests on Galvanised items (Visual, Hammer Test, Knife Test, Thickness, Pierce Test (Copper sulphate test), Hydrogen evaluation test, Stripping test (for Mass of Zinc coating)</li> <li>q) All tests as per BHEL Product Standard &amp; approved drawings including Type tests and Routine tests on individual items and on System as a whole.</li> <li>r) Packing and Preservation.</li> </ol> <p>16. <b>QAP Format enclosed.</b></p> <p>17. For inspections outside India, customer/PMC approved TPIA to be hired by vendor and TPIA charges to be borne by vendor.</p> <p>TPIA list:</p> <ol style="list-style-type: none"> <li>a. M/s TUV SUD South Asia Pvt. Ltd.</li> <li>b. M/s SGS India Pvt. Ltd.</li> <li>c. M/s VCS Quality Services Private Limited</li> <li>d. M/s International Certification Services Pvt. Ltd.</li> <li>e. M/s ABS Industrial verification Pvt. Ltd.</li> </ol>		
Ref. Doc			

	Form No.	 HYDERABAD	<p align="center"><b>PRODUCT STANDARD</b></p> <p align="center">PROJECT ENGINEERING &amp; SYSTEMS DIVISION HYDERABAD</p>	ANNEXURE
				Rev No. 00
				Page 4 of 4
<p align="center"><b>COPYRIGHT AND CONFIDENTIAL</b></p> <p>The information on this document is the property of BHARAT HEAVY ELECTRICALS LIMITED . It must not be used directly or indirectly in any way detrimental to the interest of the company.</p>	<p>f. M/s Projects and Development India Ltd.</p> <p>g. M/s TATA Project Limited</p> <p>h. M/s Certification Engineers International Limited</p> <p>i. M/s Bureau Veritas (India) Pvt. Ltd.</p>			
Ref. Doc				

