

22267-0000-V-3
DRAWING NO.

SL. NO	DRAWING NO	MATL CODE	$\phi D \begin{smallmatrix} +2 \\ 0 \end{smallmatrix}$	$L \begin{smallmatrix} +4 \\ 0 \end{smallmatrix}$	WEIGHT	SIZE
01	3-V-L915-22267/00	964605530000	236	83	1.65	8"/300C
02	3-V-L929-22267/00	964605540000	343	83	2.5	12"/150C
03	3-V-L943-22267/00	964605550000	432	83	4.07	16"/150C
04	3-V-L957-22267/00	964605560000	646	83	7.78	24"/150C
05	3-V-L820-22267/00	964605570000	533	100	6.13	18"/600C
06	3-V-L825-22267/00	964605580000	187	53	0.92	6"/300C
07	3-V-L841-22267/00	964605590000	297	53	1.82	10"/300C
08	3-V-L857-22267/00	964605600000	352	53	2.44	12"/300C
09	3-V-L873-22267/00	964605610000	192	53	0.96	6"/600C
10	3-V-L889-22267/00	964605620000	397	53	2.98	14"/600C
11	3-V-L893-22267/00	964606420000	358	53	2.6	14"/150C(REDCER)
12	3-V-L805-22267/00	964606430000	459	100	5.9	18"/150REDUCER
13	3-V-L890-22267/00	964606520000	561	70	5.825	22"/18"REDUCER
14	3-V-L891-22267/00	964606530000	408	25	2.555	16"/18"REDUCER
15	3-V-L725-22267/00	964606540000	573	50	5.467	20"/300C
16	3-V-L751-22267/00	964606550000	713	70	8.737	28"/26"REDUCER
17	3-V-L752-22267/00	964606560000	702	75	8.681	24"/600C
18	3-V-L984-22267/00	964606570000	385	40	2.591	16"/300C
19	3-V-L783-22267/00	964606580000	430	85	4.09	16"/600C
20	3-V-L793-22267/00	964606980000	934	100	15.3	32"/600C
21	3-V-L789-22267/00	964606990000	854	100	13.1	32"/150C
22	3-V-L507-22267/00	964607450000	319	60	2.3	10"/600C
23	3-V-L508-22267/00	964607460000	221	30	1.0	8"X10"REDUCER
24	3-V-L794-22267/00	964607930000	944	150	19.5	32"/600C
25	3-V-L985-22267/00	964608140000	390	40	2.68	16"/300C
26	3-V-LA41-22267/00	964620310000	950	150	19	32"/900C

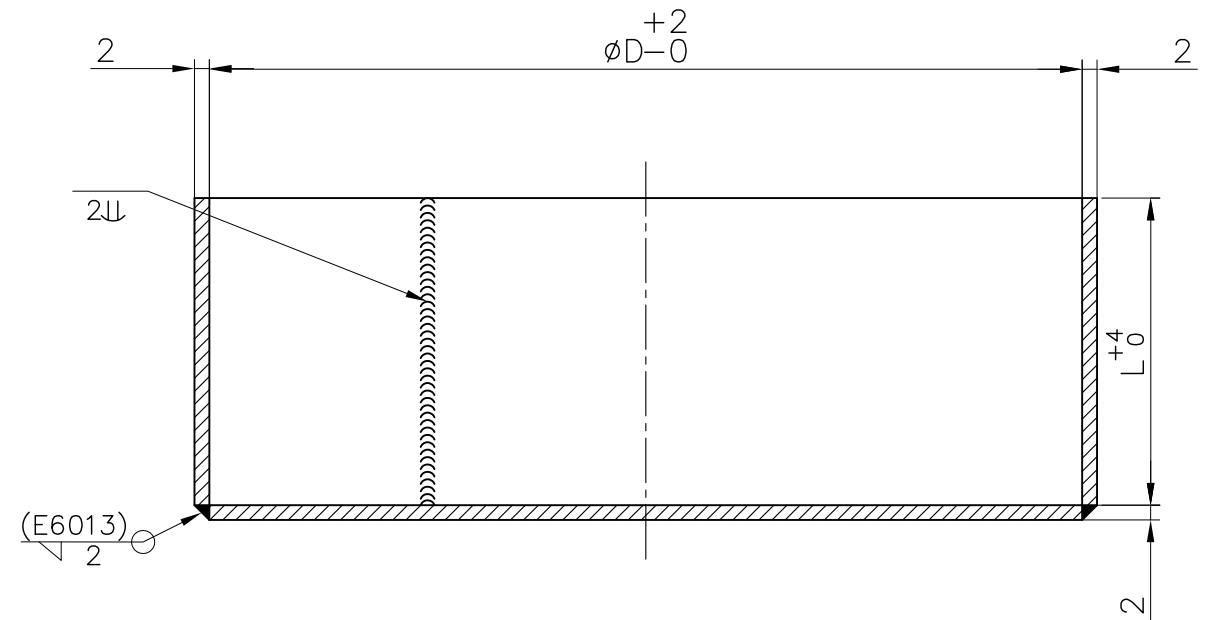

NOTE:

MATERIAL SPECIFICATION IS 1079 GR.ST 34.

NO OFF	DESCRIPTION	MATL CODE	MATL SPECN	HEAT TREATMENT	SCRAP SORT	NET WT (kg)	GROSS WT (kg)	DRAWING No	ITEM No
--------	-------------	-----------	------------	----------------	------------	-------------	---------------	------------	---------

TYPE OF PRODUCT OR NAME OF CUSTOMER/PROJECT

BHARAT HEAVY ELECTRICALS LTD., UNIT: HIGH PRESSURE BOILER PLANT. TIRUCHIRAPALLI -620014. 365-121	DRN	NAME	SIGN	DATE	NO. OF VAR.
	CHD				
	APPD				

DEPT VL	SCALE NTS	WEIGHT (KG) ---	REFERENCE INFORMATIONS	NO. OF ITEMS
---------	-----------	-----------------	------------------------	--------------

TITLE METALLIC END COVERS (FABRICATED)	CARD CODE U 01	DRAWING NO. 3-V-0000-22267	REV 08
--	----------------	----------------------------	--------

REV	DATE	ALTERED	JALAL
08	01.02.13	CHD & APPD	MRK

S.No. 25 ADDED.

CAUTION: The information on this document is the property of BHARAT HEAVY ELECTRICALS LTD. It must not be used directly or indirectly in any way detrimental to the interest of the company.