



## Bharat Heavy Electricals Limited

(High Pressure Boiler Plant)

Tiruchirappalli – 620014, TAMIL NADU, INDIA

**R & D and COAL RESEARCH**

An ISO 9001  
Company

<b>MODIFICATION &amp; ERECTION WORKS AT SUPER CRITICAL FACILITY</b>	Phone: +91 431 257 7558 Fax : +91 431 252 0696 / 252 0193 Email : <a href="mailto:mnthambi@bheltry.co.in">mnthambi@bheltry.co.in</a> Web : <a href="http://www.bhel.com">www.bhel.com</a>
---	--

<b>Reference Number: 2811100021/R&amp;D</b>	<b>Date: 19/09/2011</b>	<b>Due date for submission of quotation : 11/10/2011 by 14.00 Hours</b>
You are requested to quote the Enquiry number date and due date in all your correspondences. <i>This is only a request for quotation and not an order.</i>		

BHEL/Trichy is looking for vendors for **IBR & Non-IBR piping, instrumentation and equipment erection as per the Annexure A & B** and commercial terms & conditions attached.

Interested Fabricators / Manufacturers / Authorised dealers may send the offer on or before **11/10/2011, 14.00 Hours** in two parts as requested in the specification.

Note: The offer should reach this office on or before the due date & we are not responsible for any postal delay. Late tender will not be considered.

M.NALLATHAMBI  
MANAGER/ R&D AND COAL RESARCH

## **Specification for Erection/Modification Works in Supercritical Test Facility**

**BHARAT HEAVY ELECTRICALS LIMITED  
MHD CAMPUS TIRUCHIRAPPALLI 620 014.  
RESEARCH AND DEVELOPMENT**

### **Specification for Erection/Modification Works in Supercritical Test Facility (Also hosted in [www.bhel.com](http://www.bhel.com))**

The supercritical test facility was established in BHEL Trichy in Dec. 2008 in MHD campus. BHEL intend to make certain modifications in the supercritical test facility. The extent of modifications is detailed out in the subsequent pages.

#### **1.0 Scope of Work**

The work content is as per Annexure A (1 page) for IBR jobs and Annexure B (2 pages) for non-IBR jobs involving the following activities

- Handling of Erection materials and equipment from the storage yard (within 500 meters) to erection site
- Lifting, positioning, aligning, fixing /erecting the materials /equipment by fastening or welding as per the drawing / instruction form BHEL.
- Cutting / modification of raw materials / existing equipment / structure to suit new equipment.
- Fabrication of minor pipe line bends and supports
- Painting of steel surfaces including marking flow directions and writing of pipeline name with colours as specified by BHEL.
- Erection of Stainless Steel and alloy steel piping works involving IBR quality weld joints
- Dismantling and re-fixing of thermal insulation and thermocouples

Note: The L1 offer will be decided by combining the offers for annexure A and annexure B together.

#### **2.0 Type of materials to be handled**

Structural, Stainless Steel / Alloy steel pipe lines, Nickel alloy tube, valves, high pressure flange, flow measurement orifice, instruments etc.

#### **3.0 Responsibility of Contractor**

3.1 Contractor has to bring sufficient quality and quantity of the following

- a. Material handling and lifting devices.
- b. Welding generators, welding set, and consumables (BHEL can issue electrodes if available and deduct from the bill payable).
- c. Gas cutting set and consumables.
- d. Portable grinding equipment
- e. Paint.
- f. All required tools and tackles.

### **Specification for Erection/Modification Works in Supercritical Test Facility**

- g. All safety equipment for the personnel employed namely safety shoes, belt, helmet, goggles, gloves, first aid medicines etc.
  - h. Electrical utilities required for the work.
- 3.2 Radiography & heat treatment, LPI, MPI as per IBR also included in contractor's scope.
- 3.3 It is the responsibility of the contractor to arrange for required scaffolding.
- 3.4 Any modification in structure / platform for removing and installing new equipments shall be in the scope of the contractor.
- 3.5 It is the responsibility of the contractor to take care of the compensations for the injury or loss of life of personnel employed by him for the work. Insurance shall be in the scope of contractor.
- 3.6 All the men & equipment required for erection shall be in our general instruction of tender like ESI, PF etc. to their permanent employees in their contract shall be in contractor's scope.
- 3.7 Transportation should be arranged by the contractor for transportation of erection materials from Stores/ Storage yard to Erection site.
- 3.8 Accommodation, transport & canteen facilities for all the personnel are to be arranged by the contractor at his cost.
- 3.9 For storing contractor's materials as well as the materials drawn by him from our stores, the contractor should make suitable arrangements at their own risk.
- 3.10 The contractor shall clearly register at the gate with security for the materials, tools, plant, tackles and lifting devices. No items will be permitted to take out of BHEL after completing works and without proper entry in the gate. The contractor shall furnish the copy of list of inward items to BHEL.
- 3.11 The entire surplus unused materials supplied (by Bharat Heavy Electricals Ltd) if any, shall be returned to BHEL in the condition in which they were received. The contractor shall, during the progress of work provide, erect and maintain necessary stores, office and temporary workshops required for the proper and efficient execution of the work at his own cost. The planning and layout of temporary building shall have the approval of BHEL Engineer.

#### **4.0 Scope of BHEL**

BHEL will provide all guidance and clarifications for erection; supply all materials and equipment, electrodes (if available on chargeable basis), power, water and compressed air supply.

## **Specification for Erection/Modification Works in Supercritical Test Facility**

### **5.0 Duration**

The tentative date of starting the work is 01.11.2011 or within one week from the date of PO if the order is placed after 1<sup>st</sup> November 11. The work should be completed within 20 day from the date of starting the work.

### **6.0 Work Location and content**

Location: STF building in MHD Complex of BHEL, Tiruchirappalli.

Maximum work elevation: + 15 m from ground level.

Maximum weight of a single component: 100 kg.

### **7.0 Inspection**

Inspection of the erection, modification work will be carried out by BHEL site In-charge (or) his authorized persons at site.

### **8.0 Guarantee Clause**

The contractor stands guarantee for workmanship and consumables used in the works carried out by him for a period of one year from the date of completion or commissioning whichever is earlier. The contractor has to rectify any defect found during operation within one year free of charge.

### **9.0 Terms Of Billing and Payment**

90% payment will be made only after completion of all categories of work in all aspects duly certified by the site In-charge. So, payment and billing will be for only one time.

Balance 10% payment will be made after successful completion of one year service.

### **10.0 Submission of Bids**

For the date of bid submission please refer the enquiry.

1. Part I technical and unpriced commercial bid.
2. Part II price bid (unit rate as well as total rate should be filled in the BOM / price schedule).

Documents to be submitted along with the technical bid:

1. Valid IBR welder certificate of the welders who will carry out the welding works.
2. Work experience detail.
3. Reference list.
4. Signed copy of work specification to ensure that vendor has understood all the terms and conditions of the contract. (i.e. each and every page of the work specification should be signed)

**Specification for Erection/Modification Works in Supercritical Test Facility**

Bid shall be submitted to:

**AGM, MM / R&D and CR  
COAL RESEARCH CENTRE BUILDING  
BHART HEAVY ELECTRICALS LIMITED  
TIRUCHY-620 014.  
TAMILNADU**

**11.0 Tender Opening**

Offers shall be in two parts viz. (1) Technical Offer and (2) Financial Offer

Technical bid opening Date: As per the enquiry, at the office of AGM, MM / R&D AND CR, Coal Research Centre Building, BHEL, Trichy-14

Financial bid opening date will be intimated to the technically qualified vendor after evaluation of Technical bids.

Bidders are advised to visit the erection site (ScTF Building) at MHD complex, Tiruchy-14, in order to understand the work content, assess the tools and plant requirement and to see the actual site conditions before submitting offer. For any clarifications and scope of work bidders may contact Shri DJ Deka, Sr.Engineer/R&D (0431 – 2578653, 9442233213) or Shri R.Dhanuskodi Sr. Manager/ R&D/ MHD Complex (0431 – 2578618, 9442502593).

Bidders may forward their sealed competitive offer reply along with EMD amount of Rs. 10,000/- pledged to BHEL, Tiruchy in Demand Draft or BHEL Cash Receipt and addressed to:

**AGM, MM / R&D and CR  
COAL RESEARCH CENTRE BUILDING  
BHART HEAVY ELECTRICALS LIMITED  
TIRUCHY-620 014.  
TAMILNADU**

The duly filled offer mentioning tender reference and date of opening on the envelope along with a list of recent works carried out in BHEL detailing the work, value, start and completion dates against schedule and the name of the BHEL engineer responsible for the work shall reach us in time. Quotation received after the stipulated time will not be considered. The offer shall be kept valid for a period of 3 months from the date of Tender Opening.

**12.0 QUALITY CONTROL PROCEDURE FOR ERECTION**

General standard adopted by BHEL or Quality checks shall be guidelines for erection. However, in some cases, the site Engineer shall decide the tolerance for checks and the same will be informed to the contractor in advance.

## **Specification for Erection/Modification Works in Supercritical Test Facility**

### **13.0 SPECIAL CONDITIONS OF CONTRACT**

- 13.1 The intent of specification to provide erection services according to modern technique and codes. The mission of specific reference to any method equipment or material necessary for the proper and efficient erection of the plant shall not relieve the contractor of the responsibility of providing such facilities to complete the erection.
- 13.2 Should any error or ambiguity be discovered in the specification or information, the contractor shall clarify the same with the ScTF site in-charge of Bharat Heavy Electricals Ltd, Trichy before commencement of work. The BHEL Engineer's interpretation in such cases shall be final and binding on the contractor.
- 13.3 In case of any part work for which there is no specification as laid down in the contract, such work shall be carried out as per the instructions and requirement of the BHEL site Engineer.
- 13.4 The entire works or part of works shall not be off loaded or subcontracted except radiography and heat treatment.

### **14.0 Idle labour Charge And Period Of Completion**

- 14.1 BHEL will have no liability to any stoppage caused in the work resulting in the labour of the contractor being idle either due to the above, maintenance work or breakdown of the erection equipment, tools and tackles to be supplied by Bharat Heavy Electricals Ltd if any, or due to other causes arising from the manner of execution of the work.
- 14.2 The erection will be deemed to be completed in all respect only when trial runs and acceptance of the equipment are over. The decision of the Bharat Heavy Electricals Ltd Engineer in this respect shall be final and binding on the contractor.

### **15.0 Charges For Modification And Rectification**

- 15.1 If any modification or rectification in the erection work is needed due to any change in or deviation from the design of the equipment, extra charge at agreed rates shall be paid, provided the same has not arisen directly or indirectly on account of the contractor's fault.
- 15.2 For the purpose of the extra payment for which the contractor is eligible, the tenderer shall indicate in his tender the single man-hour rate applicable to all categories of his workmen. The consumables used if any for the modification and rectification as approved by the Engineer-in-charge shall be in contractor's scope.
- 15.3 All other modification and rectification shall be carried out by the contractor at his own cost. The decision of the engineer whether the modification or rectification is of major in nature or not shall be final and binding on the contractor.
- 15.4 All works such as cleaning, leveling, aligning, assembly, temporary erection for checking, dismantling surface preparation, edge preparation of pipes and plates for welding, fitting, welding, cutting, grouting straightening at which in the Engineers opinion are incidental to

## **Specification for Erection/Modification Works in Supercritical Test Facility**

the final satisfactory erection shall be carried out by the contractor for which no extra claim shall be allowed.

### **16.0 Contractor's Personnel**

- 16.1 The contractor shall employ especially skilled labour in addition to semi skilled and unskilled labour required for erection work. In case, the labour strength has to be increased to complete the erection work within the stipulated period, no extra claim for payment under any circumstances will be entertained. The contractor shall employ only fully trained men with previous experience on similar jobs. Bharat Heavy Electricals Ltd reserves the right to decide the suitability of workers and other personnel who may be employed by the contractor.
- 16.2 It is the responsibility of the contractor to have the required number of qualified supervisory Engineering staff who can read drawings and execute the works as per the drawing and control contractor's labour force.
- 16.3 The supervisory staff employed by the contractor shall also ensure proper out turn of work and discipline by the labour to be put on the job by the contractor and in general see in coordination with the staff of BHEL.
- 16.4 The contractor shall be responsible for the better House keeping of his stores, work spot etc and he shall instruct his staff accordingly.
- 16.5 The contractor shall ensure that his workers and staff engaged on the erection work will work and behave in general conformity with the prevailing codes of discipline prescribed by the contractor for its own work and staff. The contractor shall retain the right to order for removing from its property any person not complying with safe legal and reasonable rules of behavior and operation of vehicles and equipment.
- 16.6 The contractor shall arrange for PF and ESI for his employees. All documents pertaining to the welfare of the employees shall be submitted to BHEL's welfare/other concerned department for scrutinizing & clearing before the start of the contract work. The contractor shall also arrange necessary insurance coverage for tools, tackles and other instruments and equipment required for erection. The contractor shall not claim for any damages for the above from BHEL.

### **17.0 Erection**

- 17.1 The scope of erection includes the transporting the material from the storage yard, alignment, welding, leveling, adjusting etc till the equipments are finally tested and approved for acceptance and are taken over by BHEL for putting into operation. The contractor shall provide himself all consumables in sufficient quantities like electrodes, oxygen and acetylene gas, kerosene, grease, sleepers, scaffolding materials, etc, required for the erection work. The materials supplied and used shall be the best quality and has the approval of BHEL.
- 17.2 Erection by contractor includes the following items of work among the other things.

**Specification for Erection/Modification Works in Supercritical Test Facility**

- a) Taking a proper inventory of all the equipment, machinery and other materials collected and stored at the work site for erection.
  - b) Checking up the equipment, machinery and other materials to ensure that they conform to the specifications laid down in the contract and drawings & also to make sure that they are in proper condition to be taken up for erection.
  - c) Arranging for the overhaul of any defective or unsuitable items of equipment, machinery of material.
  - d) Arranging for the procurement and ensure availability at site at the time of erection work all consumable construction materials for erection work as may be needed to execute the handling and erection work.
  - e) Engaging and allotting adequate number of engineers, erectors and workmen of all the required categories (supervisory, skilled, semiskilled, unskilled labour) for carrying out different items at different stages of the erection work. The contractor shall nominate one engineer/officer as representative of the contractor who will be posted to site when the contractor shall contact for any matter. Any notice to him shall deem to be the notice to contractor.
  - f) Checking up each individual item of the equipment as also each individual lines to ensure that the erection of these items have been properly carried out in conformity with the erection drawing and instruction as given by the contractor.
- 17.3 After all the installation and assembly work is completed, the entire plant assembly including the pipe lines shall be checked for leak test, to ensure that individual items of equipment including pipe lines have been properly installed. The pipe lines shall be checked up by tests to make sure that all the fittings, etc have been properly fitted up and that there are no leakages or wrong connection of interconnecting pipes etc. The testing shall be in accordance with Indian standards or accepted international standard. In the absence of either, the work shall conform to the best prevalent practice. **Pre heating, post heating, radiography, SR, LPI, MPI requirements for all IBR quality weld joints must be carried out as per the quality control procedures. The welders engaged for such works should have valid IBR certification.**
- 17.4 It is only after the entire plant assembly has been thoroughly checked up on the lines indicated above and found satisfactory that the erection work shall be deemed to be completed and the equipment considered ready for commissioning. The authorized representatives of the contractor shall issue a certificate regarding the completion of the erection work to the effect that the whole plant has been tested properly.
- 17.5 The contractor will get allotted a suitable open space within a reasonable distance from the actual site of work for the storage of the equipment, materials required for the erection work of the plant. BHEL accepts no responsibility for the loss or damage to the contractor's materials arising from any reason. The responsibility of safeguarding against any such possible losses or damages rests with the contractor.
- 17.6 The contractor shall comply with provisions of the payment of wages act 1936, minimum wages act 1948, Employers liability Act 1938, workmen's compensation Act 1923,

**Specification for Erection/Modification Works in Supercritical Test Facility**

Industrial disputes act 1947, maternity benefit act 1961, and mines act 1970, or any modifications there-of or any other law relating thereto and rules made there under from time to time.

- BHEL does not accept any liability for any payment, towards the non payment wages & other payments in full / part to their workmen and staff. The contractor shall agree to indemnify and save BHEL from any such claim made directly or indirectly at any point of time.
- 17.8 BHEL does not accept any liability for any payment towards the reimbursement of loss or damage to the contractor's materials, for payment of any compensation for injuries including the loss of life to their workmen & staff, resulting from causes of circumstances which are not of contractor's making at any time during the period of erection.
- 17.9 The contractor shall bear all loss, expense and damage in connection with and agrees to indemnify and save BHEL harmless of, from and against all claims, demands, losses, expenses and judgments made or recovered by reason of liability imposed by law upon the contractor for damages because of personal injury, including death at any time resulting there from, sustained by any employee of the contractor or its sub contractor(s) and whether or not arising out of or in consequence of the performance of this contract, whether such injuries are due or claimed to be due to any negligence of the contractor, the contractor or his employees, agents, subcontractors or any other person.
- 17.10 The contractor shall take all reasonable care to protect the work under erection till such time the erected equipment are taken over by Bharat Heavy Electricals Ltd. Caution notices shall be displayed by the contractor to give warning to the person working at site or access to any part which may deem to be unsafe or hazardous.
- 17.11 In case of damage or loss to any equipment of any property there of BHEL caused by the contractor 's men, while handling and erecting the same due to negligence and carelessness on the part of the contractor's men, the responsibility of loss together with overhead will be recovered from the contractor's bill. The decision of the BHEL regarding the cause as well as the extent of cost of damage is final and conclusive.
- 17.12 Until the plant and equipment are deemed to have been taken over, the contractor shall be liable and shall deem to have agreed to identify BHEL the section of negligence of the fault of the contractor or his personnel.
- 17.13 The contractor shall execute the work in a most substantial and good workmanship. The contractor shall be responsible to ensure that the workmanship conform to dimensions and tolerances given in the drawings. If any dimension of the work is found to be defective the contractor shall rectify the same at his own cost.
- 17.14 Progress Report: Contractor shall provide daily progress report as required by site in-charge indicating the major activities and the stages of completion.

## **Specification for Erection/Modification Works in Supercritical Test Facility**

### **18.0 Cleaning of Equipment**

The contractor shall clean thoroughly the internal surface of all equipment, ducts and piping before erection by wire brush & air blowing as per the instructions of BHEL Engineer.

### **19.0 Drawing And Documents**

- 19.1 Upon award of contract, drawings/sketches shall be issued to the contractor by BHEL. All the drawing notes which will be available with the site engineer and shall form an integral part of the contract.
- 19.2 Any documents, drawings/sketches, supplied by BHEL to the contractor in pursuance of this contract shall remain the property of BHEL and any information derived shall be regarded as secret and confidential and shall not without consent in writing of BHEL, be published or disclosed either in full or part to any third party or made use of by the contractor, except for the purpose of implementation of this contract. On completion of the work, the documents drawings etc shall be returned to BHEL in good condition.

### **20.0 Facilities Provided By BHEL**

Area in open ground will be provided for storage of materials and equipments. Water including drinking water required for the labour will be supplied free of cost.

Permission for erection of temporary work sheds etc, at site will have to be obtained from BHEL in writing in advance. Subject to availability, electrical energy required for the work may be provided by BHEL free of cost at any one point at the site as decided by the Engineer In-charge. BHEL does not accept any liability whatsoever for non-supply, delay in supply, that there is no wastage of electrical energy, otherwise supply is liable to be stopped at contractor's risk and cost.

### **21.0 Safety Measures**

- 21.1 A list containing the names of person who are working, their age, designation, pay, nature of work, is to be furnished immediately on receipt of work order.
- 21.2 In all matters of dispute the decision of the General Manager, CR and R&D, BHEL, Tiruchy-14 shall be final and binding on the tenderer / contractor.
- 21.3 Some changes are likely in the quantities furnished as well as in the layout, design and specifications of the work. The rates quoted shall be deemed to be inclusive of all such contingencies.
- 21.4 All materials if any brought by the contractor for incorporation in the work shall be got inspected and approved by the Engineer In-charge before they are incorporated in the work.
- 21.5 AGM /R&D or his duly authorised representative including a third party inspection agency shall have at all reasonable times access to the contractor's premises or works and shall have the power at all reasonable times to inspect and test any portion of the work or

## **Specification for Erection/Modification Works in Supercritical Test Facility**

examine the materials and workmanship during their manufacture, erection and testing. The contractor shall give due notice in writing to the inspecting Engineer of BHEL when the materials to be supplied and incorporated are ready for inspection and test. No materials shall be incorporated in the work until the inspection Engineer has certified in writing that such materials have been inspected and approved by him.

- 21.6 The contractor shall closely scrutinize all the drawings issued in connection with the work by this organization and bring to the notice of the Engineer In-charge, any discrepancies/ omissions in the drawings before undertaking the actual work pertaining thereto.
- 21.7 The contractor should submit in advance every fortnight a detailed program of work to be undertaken from time to time strictly in conformity with the time and progress chart covering the entire constructed work and reschedule wherever necessary during the progress of the work so as to achieve the targets set. Periodical progress reports, once in every fortnight, should also be furnished by the contractor regarding the collection of materials issued and to be issued form and other relevant information as asked for by the Engineer /In-charge and other BHEL officer /office In-charge of the work.

### **22.0 Time-Essence of contract**

- 22.1 The time and date of completion of the work as stipulated in this contract shall be deemed to be the essence of the contract. The vendor shall so organize his resources and perform his work so as to complete the contract not later than the date specified.
- 22.2 The general instructions to tenderers shall be deemed to form an integral part of the contract for the work to be entered into.

### **23.0 Delayed Execution**

If the work is not completed within the due date as specified in the enquiry, due to the delay caused by the contractor even after making available all required equipment and material, a penalty of 0.5% for every week (or) part thereof beyond the due date subject to a maximum of 15% of total value of the order shall be recovered from the contractor's bill.

## Supercritical Test Facility- IBR quality works to be completed during the erection of test section tube in SctF

Sl. No	Work	Work Estimate				Unit	Unit rate (Rs)	Total (Rs)
		OD mm	Thickness mm	Number of joints	Weld material combination			
	<b>IBR quality works</b>							
1	Insitu welding of test section tube with reducer to power clamp holders	51	12	2	SS 304 Vs SS347H	No. of joints		
2	Insitu welding of pressure tapping lines	14	2.9	7	SS 347H to SS347H	No. of joints		
3	Welding of flange with SS tube	54	9.5	18	SS 347H to SS304	No. of joints		
4	Welding of SS tube with orifice	54	9.5	18	SS347H and F316	No. of joints		
5	Welding of pipe connecting test section to mixer 1	51	12	4	SS 347H to SS347H	No. of joints		
6	Welding of pipe connecting test section to mixer 1	54	9.5	2	SS 347H to SS347H	No. of joints		
7	Welding of instrumentation flange for DP transmitter	21.3	4.78	6	P22 to SS304	No. of joints		
8	Welding of instrumentation flange for DP transmitter	9.6	2	2	P22 to SS304	No. of joints		
	<b>Total</b>			<b>59</b>				

Note: Required raw materials, equipment, power and water would be provided by BHEL. The scope of work for the contractor involves material handling, pipe bending, cutting, edge preparation, positioning, aligning, heat treatment, welding, radiography and insulation. Necessary qualified working personnel, required tools, consumables and handling devices are under the scope of the contractor. Necessary pre heating, post heating and radiography requirements as per BHEL QCP and IBR requirements are to be met for all weld joints mentioned above in Annexure A. The work content variation would be +/- 10%. However, billing shall be for the actual work done at the unit rates quoted against each work.

Supercritical Test Facility- Non IBR quality works to be completed during the erection of test section tube in SctF					
Sl. No	Work	Work Estimate			
		Total	Unit	Unit rate (Rs)	Total Rate (Rs)
1	Removing of Insulation from test section tube and refixing the same after installing the new test section tube.	290	kg		
2	Removing power clamps from test section tube at top and bottom and refixing the same after installing the new test section tube.	140	kg		
3	Removing existing Thermocouple clamps before cutting and refixing the same after installing the new test section tube.	24	no of location		
4	Cutting by hacksaw of pressure tapping points (tube OD 14x2.9 mm, SS347H) from test section tube.	7	no of location		
5	Cutting by hacksaw of reducer and power clamp holder joints at top and bottom of test section tube. (tube OD 51x12 mm, SS 347H)	2	no of location		
6	Removing test section tube from site.	5	kg		

7	Cutting of OD 54x9.5mm SS tube by hacksaw.	4	no of location		
8	Fixing of test section flow measurement orifice assembly	51	kg		
9	Cutting of OD 14x2.9 mm tube connected to mixer 1	2	no of location		
10	Cutting of OD 51x12 mm tube above test section top flange	2	no of location		
11	Bending of OD 51x12 mm SS tube	6	no of bend		
12	Machining of Bore of SS Tee joint top match the size of piping	3	no of piece		

Note: Required raw materials, equipment, power and water would be provided by BHEL. The scope of work for the contractor involves material handling, pipe bending, cutting, edge preparation, positioning, aligning, welding, and insulation. Necessary qualified working personnel, required tools, consumables and handling devices are under the scope of the contractor. The work content variation would be +/- 10%. However, billing shall be for the actual work done at the unit rates quoted against each work.



# BHARAT HEAVY ELECTRICALS LIMITED

Page:1/3

**ENQUIRY**  
(INDIGENOUS)

( A Government of India Undertaking )  
HIGH PRESSURE BOILER PLANT  
PURCHASE DEPARTMENT - FOSSIL BOILERS  
THIRUCHIRAPALLI - 620014  
TAMILNADU (INDIA)

PHONE : 2577152  
GRAMS : BHARATELEC  
FAX NO: 2520193  
E-mail :  
Web :

429-002/A

**OFFICE COPY**

**Collective No.**

2811100021

**Enquiry Date**

19.09.2011

**Due Date For Quotation**

11.10.2011

Please quote Enquiry No, Date and due date in all correspondences.  
This is only a request for quotation and not an order

Item	Description	Unit	Quantity	Delivery Quantity	Schedule Date
10	IBR QUALITY PIPING WORKS INVOLVING SS AND ALLOY STEEL PIPES AS PER ANNEXURE A AND TERMS AND CONDITIONS OF CONTRACT SPECIFICATION NO. BHEL:TRY:R< (> &< )> D:2011-2012, DT: 29.08.2011 IBR QUALITY PIPING WORKS	AU	1.000	1.00	30.11.11
20	NON IBR PIPING INSTRUMENTATION AND EQUIPMENT ERECTION WORKS AS PER ANNEXURE B AND TERMS AND CONDITIONS OF CONTRACT SPECIFICATION NO. BHEL:TRY:R< (> &< )> D:2011-2012, DT: 29.08.2011 NON IBR QUALITY WORKS	AU	1.000	1.00	30.11.11

**General Note:**

- 1) OFFERS WILL BE INVITED IN TWO PART BID.
- 2) IF REGRETTED MAKE MENTION ON THE TOP OF THE REPLY COVER AS"REGRETTED"
- 3) LD CLAUSE HAS TO BE CONFIRMED WITHOUT FAIL,OTHERWISE WE WOULD ASSUME THAT YOU HAVE ACCEPTED OUR LD CLAUSE.
- 4) REQUIRED:a)TEST CERTIFICATE.b)GUARANTEE CERTIFICATE
- 5) THE PREFERRED PAYMENT TERM IS 100% PAYMENT AFTER RECEIPT AND ACCEPTANCE OF MATERIALS.
- 6) AS PER SPECIFICATION ENCLOSED.

**Enclosures:**

"LD clause has to be confirmed without fail."  
"Payment to vendors will be made only thro E-Payment mode."

**PR Links**

Material.	PR.No	PR.Item.	Quantity	Acc. Assign	Customer Number
	3000010160	00010	1.000	/000000	

The offers should reach us 30 minutes before the time of opening of tenders.  
The offers will be opened at 14.30 hrs on the due date of tender in the presence of tenderers who have submitted their offer and who may like to be present for the tender opening.Late and delayed offers are liable to be rejected.

Yours faithfully,  
For **BHARAT HEAVY ELECTRICALS LIMITED**

MANAGER / PURCHASE  
(FOSSIL BOILERS)

# **GUIDELINES FOR**

**WELDING, NDE**

**AND**

**HEAT TREATMENT**

THIS BOOKLET IS GIVEN AS A GENERAL GUIDELINE TO THE TENDERERS ABOUT WELDING, NDE & HT FOR THE PIPING SYSTEMS, HOWEVER INSTRUCTIONS GIVEN IN THE DRAWINGS & WELDING SCHEDULE ISSUED DURING EXECUTION OF THE WORK SHALL BE FINAL AND BINDING OF THE CONTRACTOR.

**BHEL PSSR SCT :**

**BOOK NO :**



**BHARAT HEAVY ELECTRICALS LIMITED**

(A Government of India Undertaking)

Power Sector – Southern Region

690, Anna Salai, Nandanam, Chennai – 600 035.

# BASE MATERIALS

- 1.0 Scope:
- 1.1 This chapter contains tabulations of chemical compositions & mechanical properties of various materials generally used in BHEL sites.
- 2.0 Contents:
  - Table 1 - Pipes (ASME)
  - Table 2 - Tubes (ASME)
  - Table 3 - Forgings (ASME)
  - Table 4 - Castings (ASME)
  - Table 5 - Plates / Sheets (ASME)
  - Table 6 - Pipes (Other specifications)
  - Table 7 - Tubes (Other specifications)
  - Table 8 - Forgings (Other specifications)
  - Table 9 - Barstock
- 3.0 The data are for general information purposes. The corresponding P Numbers are also indicated.
- 4.0 For materials not covered in this chapter, the supplier shall be contacted.

## CHEMICAL COMPOSITION AND MECHANICAL PROPERTIES

Table - 1 Pipes

Sl. No	P.NO / Group No.	Material Specification (ASME)	Chemical Composition (%)								Mech. Properties (Min.)		
			C	Mn	P	S	Si	Ni	Cr	Mo	T.S. kg/mm <sup>2</sup>	Y.S. kg/mm <sup>2</sup>	%E Min
1	P 1/1	SA 106 Gr.B (Remarks: Carbon restricted to 0.25% Max.)	0.30 Max.	0.29-1.06	0.048 Max.	0.058 Max.	0.10 Max	-	-	-	42	25	30
2	P 1/1	SA 672 Gr.B, Cl.22 Max	0.24 Max.	0.9 Max.	0.035 Max.	0.04 Max.	0.15-0.30	-	-	N 0.009 Max.	42.2-50.6	22.5	25
3	P 1/2	SA 106 Gr.C	0.35 Max.	0.29-1.06	0.048 Max.	0.058 Max.	0.10 Max	-	-	-	49	28	30
4	P 4/1	SA 335 P 11	0.15 Max.	0.3-0.6	0.03 Max.	0.03 Max.	0.5 Max.	-	1.0-1.5	0.44-0.65	42	21	30
5	P 4/1	SA 335 P 12	0.15 Max.	0.3-0.60	0.045 Max.	0.045 Max.	0.5 Max.	-	0.8-1.25	0.44-0.65	42	21	30
6	P 5/1	SA 335 P 22	0.15 Max.	0.3-0.61	0.03 Max.	0.03 Max.	0.5 Max.	-	1.9-2.6	0.87-1.13	42	21	30
7	P 8/1	SA 376 TP 321H (Titanium Stabilised)	0.04-0.10	2.0 Max	0.04 Max.	0.03 Max.	0.75 Max.	9.0-13.0	17.0-20.0	-	53	21	35
8	P 8/1	SA 376 TP 304H	0.04-0.10	2.0 Max	0.04 Max.	0.03 Max.	0.75 Max.	8.0-11.0	18.0-20.0	-	53	21	35
9	P 8/1	SA 376 TP 316H	0.04-0.10	2.0 Max	0.04 Max.	0.03 Max.	0.75 Max.	11.0-14.0	16.0-18.0	-	53	21	35
10	P 8/1	SA 376 TP 347H (Cb+Ta Stabilised)	0.04-0.10	2.0 Max	0.04 Max.	0.03 Max.	0.75 Max.	9.0-13.0	17.0-20.0	-	53	21	35

**CHEMICAL COMPOSITION AND MECHANICAL PROPERTIES**  
Table – 2 Tubes

Sl. No	P.NO / Group No.	Material Specification (ASME)	Chemical Composition (%)								Mech. Properties (Min.)		
			C	Mn	P	S	Si	Ni	Cr	Mo	T.S. kg/mm <sup>2</sup>	Y.S. kg/mm <sup>2</sup>	%E Min
1	P 1/1	SA 192	0.06-0.18	0.27-0.63	0.048 Max.	0.053 Max.	0.25 Max.	-	-	-	33	18	35
2	P 1/1	SA 210 Gr A1	0.27-0.18	0.93 Max	0.048 Max.	0.058 Max.	0.10 Max.	-	-	-	42	26	30
3	P 1/1	SA 179	0.062-0.18 Max.	0.27-0.63	0.048 Max.	0.058 Max.	-	-	-	-	-	-	-
4	P 1/2	SA 210 Gr. C	0.35 Max.	0.29-1.06	0.048 Max.	0.058 Max.	0.10 Max	-	-	-	49	28	30
5	P 1/2	SA 556 Gr C2	0.3 Max.	0.29 Max.	0.048 Max.	0.048 Max.	0.10 Max	-	-	-	49	28	25
6	P 3/1	SA 209 T1	0.10-0.20	0.3-0.8	0.045 Max.	0.045 Max.	0.10-0.50	-	-	0.44-0.65	39	21	30
7	P 3/1	SA 209 T1a	0.05-0.25	0.3-0.8	0.045 Max.	0.045 Max.	0.10-0.50	-	-	0.44-0.65	42	22.4	30
8	P 3/1	SA 209 T1b	0.14 Max.	0.3-0.8	0.045 Max.	0.045 Max.	0.10-0.50	-	-	0.44-0.65	37	20	30
9	P 4/1	SA 213 T11	0.15 Max.	0.30-0.60	0.03 Max.	0.03 Max.	0.5-1.0	-	1.0-1.5	0.44-0.65	42	21	30
10	P 4/1	SA 213 T12	0.15 Max.	0.30-0.61	0.045 Max.	0.045 Max.	0.5 Max.	-	0.8-1.25	0.44-0.65	42	21	30

## CHEMICAL COMPOSITION AND MECHANICAL PROPERTIES

Table – 2 Tubes (Contd..)

Sl. No	P.NO / Group No.	Material Specification (ASME)	Chemical Composition (%)								Mech. Properties (Min.)		
			C	Mn	P	S	Si	Ni	Cr	Mo	T.S. kg/mm <sup>2</sup>	Y.S. kg/mm <sup>2</sup>	%E Min
11	P 5/1	SA 213 T22	0.15 Max.	0.30-0.60	0.03 Max.	0.03 Max.	0.50 Max.	-	1.9-2.60	0.87-1.13	42	21	30
12	P 5/1	SA 213 T5	0.15 Max.	0.30-0.60	0.030 Max.	0.03 Max.	0.50 Max.	-	4.0-6.0	0.45-0.65	42	21	30
13	P 5/2	SA 213 T9	0.15 Max.	0.30-0.60	0.03 Max.	0.03 Max.	0.25-1.00	-	8.0-10.0	0.9-1.10	42	21	30
14	P 8/1	SA 213 TP 321H (Ti Stabilised)	0.04-0.10	2.0 Max.	0.04 Max.	0.03 Max.	0.75 Max.	9.0-13.0	17.0-20.0	-	53	21	35
15	P 8/1	SA 213 TP 304 H	0.04-0.10	2.0 Max.	0.04 Max.	0.03 Max.	0.75 Max.	8.0-11.0	18.0-20.0	-	53	21	35
16	P 8/1	SA 213 TP 304	0.08 Max.	2.0 Max.	0.04 Max.	0.03 Max.	0.75 Max.	8.0-11.0	18.0-20.0	-	53	21	35
17	P 8/1	SA 249 TP 304	0.08 Max.	2.0 Max.	0.04 Max.	0.03 Max.	0.75 Max.	8.0-11.0	18.0-20.0	-	53	21	35
18	P 8/1	SA 688 TP 304	0.08 Max.	2.0 Max.	0.04 Max.	0.03 Max.	0.75 Max.	8.0-11.0	18.0-20.0	-	53	21	35
19	P 8/1	SA 213 TP 316 H	0.04-0.10	2.0 Max.	0.04 Max.	0.03 Max.	0.75 Max.	11.0-14.0	16.0-18.0	2.0-3.0	53	21	35
20	P 8/1	SA 213 TP 347 H (Cb+Ta Stabilised)	0.04-0.10	2.0 Max.	0.04 Max.	0.03 Max.	0.75 Max.	9.0-13.0	17.0-20.0	-	53	21	35

## CHEMICAL COMPOSITION AND MECHANICAL PROPERTIES

Table – 3 Forgings

Sl. No	P.NO / Group No.	Material Specification (ASME)	Chemical Composition (%)								Mech. Properties (Min.)		
			C	Mn	P	S	Si	Ni	Cr	Mo	T.S. kg/mm <sup>2</sup>	Y.S. kg/mm <sup>2</sup>	%E Min
1	P 1/2	SA 105	0.35 Max	0.6-1.05	0.04 Max.	0.05 Max.	0.35 Max.	-	-	-	49	25.2	30
2	P 4/1	SA 182 F12	0.10-0.20	0.3-0.8	0.04 Max.	0.04 Max.	0.1-0.6	-	0.8-1.25	0.44-0.65	49	28	20
3	P 5/1	SA 182 F22	0.15 Max.	0.3-0.6	0.04 Max.	0.04 Max.	0.5 Max.	-	2.0-2.5	0.87-1.13	52.5	31.5	20
4	P 8/1	SA 182 F321 H (Ti Stabilised)	0.04-0.10	2.0 Max.	0.04 Max.	0.03 Max.	1.00 Max.	9.0-12.0	17.0-Min	-	52.5	21	30
5	P 8/1	SA 182 F304 H	0.04-0.10	2.0 Max.	0.04 Max.	0.03 Max.	1.00 Max	8.0-11.0	18.0-20.0	-	52.5	21	30
6	P 8/1	SA 182 F316 H	0.04-0.10	2.0 Max.	0.04 Max.	0.03 Max.	1.00 Max	10.0-14.0	16.0-18.0	2.0-3.0	52.5	21	30
7	P 8/1	SA 182 F347 H (Cb+Ta Stabilised)	0.04-0.10	2.0 Max.	0.04 Max.	0.03 Max.	1.00 Max	9.0-13.0	17.0-20.0	-	52.5	21	30

## CHEMICAL COMPOSITION AND MECHANICAL PROPERTIES

Table – 4 Castings

Sl. No	P.NO / Group No.	Material Specification (ASME)	Chemical Composition (%)								Mech. Properties (Min.)		
			C	Mn	P	S	Si	Ni	Cr	Mo	T.S. kg/mm <sup>2</sup>	Y.S. kg/mm <sup>2</sup>	%E Min
1	P 1/2	SA 216 WCB	0.3 Max.	1.0 Max.	0.04 Max.	0.045 Max.	1.60 Max.	0.5 Max.	0.5 Max.	0.20 Max.	49	25.2	22
2	P 1/2	SA 216 WCC	0.25 Max.	1.20 Max.	0.04 Max.	0.045 Max.	0.60 Max.	0.5 Max.	0.5 Max.	0.20 Max.	49	28	22
3	P 3/1	SA 217 WC1	0.25 Max.	0.5-0.8	0.04 Max.	0.045 Max.	0.6 Max.	-	-	0.45-0.65	45.5	24.5	24
4	P 4/1	SA 217 WC6	0.2 Max.	0.5-0.8	0.04 Max.	0.045 Max.	0.6 Max.	-	1.0-1.5	0.45-0.65	49	28	20
5	P 5/2	SA 217 C 5	0.2 Max.	0.4-0.7	0.04 Max.	0.045 Max.	0.75 Max.	-	4.0-6.5	0.45-0.65	63	42	18
6	P 5/1	SA 217 WC 9	0.18 Max.	0.4-0.7	0.04 Max.	0.045 Max.	0.6 Max.	-	2.0-2.75	0.9-1.20	49	28	20
7	P 8/1	SA 351 CF 8	0.08 Max.	1.5 Max.	0.04 Max.	0.04 Max.	2.0 Max.	8.0-11.0	18.0-21.0	0.5 Max.	49	21	35
8	P 8/1	SA 351 CF 8M	0.08 Max.	1.5 Max.	0.04 Max.	0.04 Max.	1.5 Max.	9.0-12.0	18.0-21.0	2.0-3.0	49	21	30
9	P 8/1	SA 351 CF 8C	0.08 Max.	1.5 Max.	0.04 Max.	0.04 Max.	2.0 Max.	9.0-12.0	18.0-21.0	0.5 Max.	49	21	30
10	P 8/2	SA 351 CH 20	0.20 Max.	1.5 Max.	0.04 Max.	0.04 Max.	2.0 Max.	12.0-15.0	22.0-26.0	0.5 Max.	49	21	30

## CHEMICAL COMPOSITION AND MECHANICAL PROPERTIES

Table – 5 Plates / Sheets

Sl. No	P.NO / Group No.	Material Specification (ASME)	Chemical Composition (%)								Mech. Properties (Min.)		
			C	Mn	P	S	Si	Ni	Cr	Mo	T.S. kg/mm <sup>2</sup>	Y.S. kg/mm <sup>2</sup>	%E Min
1	P 1/1	SA 516 Gr 60	0.21-0.25	1.85-1.20	0.035 Max.	0.04 Max.	0.15-0.40	-	-	N 0.009	56	26	25
2	P 1/2	SA 516 Gr 70	0.35 Max.	0.85-1.20	0.035 Max.	0.04 Max.	0.15-0.40	-	-	N 0.009	49-63	27	21
3	P 1/3	SA 299	0.30 Max.	0.84 Max.	0.035 Max.	0.04 Max.	0.13-0.45	-	-	-	52.5-66.5	29.4	19
4	P 1/2	SA 515 Gr 70	0.35 Max.	1.3 Max.	0.035 Max.	0.04 Max.	0.13-0.45	-	-	-	49.2-63	26.6	21
5	P 4/1	SA 387 Gr 12	0.17 Max.	0.35-0.73	0.035 Max.	0.04 Max.	0.13-0.45	-	0.74-1.21	0.40-0.65	38.5-56.0	23.1	22
6	P 5/1	SA 387 Gr 22	0.15 Max.	0.25-0.66	0.035 Max.	0.035 Max.	0.5 Max.	-	1.88-2.62	0.85-1.1	42-59.5	21	18
7	P 8/1	SA 240 TYPE 321 (Ti Stabilised)	0.08 Max.	2.0 Max.	0.045 Max.	0.03 Max.	1.0 Max.	9.0-12.0	17.0-19.0	-	52.5	21	40
8	P 8/1	SA240 – TYPE 304	0.08 Max.	2.0 Max.	0.045 Max.	0.03 Max.	1.0 Max.	8.0-10.5	18.0-20.0	-	52.5	21	40
9	P 8/1	SA240 – TYPE 316	0.08 Max.	2.0 Max.	0.045 Max.	0.03 Max.	1.0 Max.	10.0-14.0	16.0-18.0	2.0-3.0	52.5	21	40
10	P 8/1	SA240 – TYPE 347 Ca+Ta Stabilised	0.08 Max.	2.0 Max.	0.045 Max.	0.03 Max.	1.0 Max.	9.0-13.0	17.0-19.0	-	52.5	21	40

## CHEMICAL COMPOSITION AND MECHANICAL PROPERTIES

Table – 6 Pipes  
(Other Specifications)

Sl. No	P.NO / Group No.	Material Specification	Chemical Composition (%)									Mech. Properties (Min.)		
			C	Mn	P	S	Si	Ni	Cr	Mo	V	T.S. kg/mm <sup>2</sup>	Y.S. kg/mm <sup>2</sup>	%E Min
1	P 1/1	DIN St 35.8	0.17 Max.	0.4- 0.8	0.04 Max.	0.04 Max.	0.10- 0.35	-	-	-	-	36.7- 48.96	24	25
2	P 1/ 1	DIN St 45.8	0.21 Max.	0.45- 1.20	0.04 Max.	0.04 Max.	0.10- 0.35	-	-	-	-	41.8- 54.1	26	21
3	P 1/1	BS 3602 410	0.21 Max.	0.40- 1.20	0.045 Max.	0.045 Max.	0.35 Max.	-	-	-	-	41.82- 56.1	25	22
4	P 1/1	BS 3602 / 460	0.22 Max.	0.80- 1.40	0.045 Max.	0.045 Max.	0.35 Max.	-	-	-	-	46.9- 61.2	28.6	21
5	P 4/1	BS 3604 620- 460 HFS or	0.10- 0.15	0.40 Max.	0.04 Max.	0.04 Max.	0.10- 0.35	-	0.70- 1.10	0.45- 0.65	-	46.9- 62.22	18.36	22
		CDS 620-440	0.10- 0.18	0.40- 0.70	0.04 Max.	0.04 Max.	0.10- 0.35	-	0.70- 1.10	0.45- 0.65	-	44.9- 60.2	29.58	22
6	P 5/1	BS 3604 622 HFS or CDS	0.08- 0.15	0.40- 0.70	0.04 Max.	0.04 Max.	0.5 Max.	-	2.0- 2.5	0.9- 1.2	-	48.8	26.8	17
7	-	BS 3604 HFS 660 or CDS 660	0.15 Max.	0.4- 0.7	0.04 Max.	0.04 Max.	0.10- 0.35	-	0.25- 0.50	0.5- 0.7	0.22- 0.30	47.3	30	17

## CHEMICAL COMPOSITION AND MECHANICAL PROPERTIES

Table – 7 Tubes  
(Other Specifications)

Sl. No	P.NO / Group No.	Material Specification	Chemical Composition (%)								Mech. Properties (Min.)		
			C	Mn	P	S	Si	Cr	Mo	V	T.S. kg/mm <sup>2</sup>	Y.S. kg/mm <sup>2</sup>	%E Min
1	P 1/1	DIN St 35.8	0.17 Max.	0.40- 0.80	0.04 Max.	0.04 Max.	0.10- 0.35	-	-	-	36.70- 48.96	24	25
2	P 1/ 1	DIN St 45.8	0.21 Max.	0.40- 1.20	0.04 Max.	0.04 Max.	0.10- 0.35	-	-	-	41.80- 54.06	26	21
3	P 1/1	BS 3059 / 360	0.17 Max.	0.4- 0.8	0.045 Max.	0.045 Max.	0.35 Max.	-	-	-	36.70- 51.00	22	24
4	P 1/1	BS 3059 / 440	0.12- 0.18	0.9- 1.20	0.040 Max.	0.035 Max.	0.10 0.35	-	-	-	44.88- 59.2	25	21
5	P 3/1	DIN 15 Mo3	0.12- 0.20	0.40 0.80	0.035 Max.	0.035 Max.	0.10- 0.35	-	0.25- 0.35	-	45.9- 61.2	27.5	22
6	P 4/1	DIN B Gr. Mo 4	0.10- 0.18	0.4- 0.7	0.035 Max.	0.035 Max.	0.10- 0.35	0.7- 1.10	0.45- 0.65	-	44.88- 60.18	29.6	22
7	P 4/1	BS 3059 / 620	0.10 0.15	0.4- 0.7	0.04 Max.	0.04 Max.	0.10- 0.35	0.7- 1.1	0.45- 0.65	-	46.9- 62.2	18.4	22

## CHEMICAL COMPOSITION AND MECHANICAL PROPERTIES

Table – 7 Tubes (Contd.)  
(Other Specifications)

Sl. No	P.NO / Group No.	Material Specification	Chemical Composition (%)								Mech. Properties (Min.)		
			C	Mn	P	S	Si	Cr	Mo	V	T.S. kg/mm <sup>2</sup>	Y.S. kg/mm <sup>2</sup>	%E Min
8	P 5/1	DIN 10 Cr Mo 910	0.08 0.15	0.4- 0.7	0.035 Max.	0.035 Max.	0.5 Max.	2.0- 2.5	0.9- 1.2	-	45.9- 61.2	28.6	20
9	P 5/ 1	BS 3059(622) – 440	0.08- 0.15	0.4- 0.7	0.04 Max.	0.04 Max.	0.5 Max.	2.0- 2.5	0.9- 1.20	-	44.9- 60.18	17.85	20
10	P 5/1	BS 3059(622)-490	0.08- 0.15	0.4- 0.7	0.04 Max.	0.04 Max.	0.5 Max.	2.0- 2.5	0.9- 1.20	-	49.98- 65.0	28.05	20
11	-	DIN 14 Mo V63	0.10- 0.18	0.4- 0.7	0.035 Max.	0.035 Max.	0.10- 0.35	0.3- 0.6	0.5- 0.7	0.22- 0.32	46.9- 62.22	32.6	20

## CHEMICAL COMPOSITION AND MECHANICAL PROPERTIES

Table – 8 Forgings  
(Other Specifications)

Sl. No	P.NO / Group No.	Material Specification	Chemical Composition (%)										Mech. Properties (Min.)		
			C	Mn	P	S	Si	Ni	Cr	Mo	V	Cu	T.S. kg/mm <sup>2</sup>	Y.S. kg/mm <sup>2</sup>	%E Min
1	P 1/1	IS 1875 CL II	0.15- 0.25	0.60- 0.90	0.05 Max.	0.05 Max.	0.15- 0.35	0.25 Max.	0.25 Max.	0.05 Max.	0.05 Max.	-	44	24	24
2	P 1/ 1	BS 1503 161 Cr 28	0.25 Max.	0.65- 1.20	0.05 Max.	0.05 Max.	0.15- 0.35	0.40 Max.	0.25 Max.	0.10 Max.	-	0.30 Max.	44.1- 52	22.1	22
3	-	BS 1503 660	0.08- 0.15	0.40- 0.70	0.04 Max.	0.04 Max.	0.10- 0.35	0.3 Max.	0.25- 0.50	0.50- 0.70	0.22- 0.32	0.25 Max.	47.2- 63	29.9	21

## CHEMICAL COMPOSITION AND MECHANICAL PROPERTIES

Table – 9 Bar stock  
(Other Specifications)

Sl. No	P.NO / Group No.	Material Specification	Chemical Composition (%)									Mech. Properties (Min.)		
			C	Mn	P	S	Si	Ni	Cr	Mo	V	T.S. kg/mm <sup>2</sup>	Y.S. kg/mm <sup>2</sup>	%E Min
1	P 1/1	IS 1570 - 1508	0.1- 0.2	0.6- 0.9	0.055 Max.	0.055 Max.	0.05- 0.35	-	-	-	-	43	-	25
2	P 1/ 1	IS 226 (St 42)	0.23 Max.	-	0.055 Max.	0.055 Max.	-	-	-	-	-	42- 54	25	23
3	P 1/1	CSN 11416.1	0.2 Max.	0.65 Max.	0.045 Max.	0.045 Max.	0.35 Max.	0.30 Max	0.30 Max.	-	-	41- 50	24	25
4	-	VX22 Cr Mo V121V	0.18- 0.23	0.3- 0.8	0.035 Max.	0.02 Max.	0.1- 0.5	0.3- 0.5	11.5- 11.9	0.8- 1.2	0.25- 0.35	95	60	15

## **RECEIPT INSPECTION OF WELDING ELECTRODES / FILLER WIRES**

1. All electrodes / filler wires received at site stores shall be segregated for type and size of electrode.
2. Ensure that electrode packets received are free from physical damage.
3. Where electrodes are damaged, the same shall be removed from use.
4. Only electrodes identified in the "Rationalized List of Electrodes" are to be accepted.
5. Where filler metals are supplied by manufacturing unit, inspect for damages, if any.
6. Ensure availability of relevant test certificates. Refer tables of chemical compositions and mechanical properties for acceptance.
7. Endorse acceptance / rejection on the test certificate.

## **STORAGE & IDENTIFICATION OF WELDING**

### **ELECTRODES / FILLER WIRES**

- 1.0 Scope
- 1.1 This procedure is applicable for storage of welding electrodes / filler wires used at sites.
- 2.0 Procedure:
  - 2.1 Only materials accepted (based on receipt inspection) shall be taken into account for storage.
  - 2.2 Storage Facility:
    - 2.2.1 The storage facility shall be identified.
    - 2.2.2 Access shall be restricted to authorized personnel.
    - 2.2.3 The storage area shall be clean and dry.
    - 2.2.4 Steel racks may be used for storage. Avoid storing wood inside the storage room.
    - 2.2.5 Maintain the temperature of the storage facility above the ambient temperature. This can be achieved by the use of appropriate heating arrangements.
  - 2.3 The electrodes / filler wire shall be segregated and identified for
    - a. Type of electrode e.g. E7018.
    - b. Size of electrode e.g. Dia 3.15 mm.

2.4 Colour coding for filler wires:

2.4.1 On receipt of GTAW filler wires, codify the filter wires as per table I below . Both ends shall be coloured.

**Table - 1**

Specification	Brand Name*	Colour Code
RT 1/ 2 Mo (ER80s-D2)	TGSM	Green
RT 1 Cr 1 / 2 Mo (ER80S-B2)	TGS 1CM	Silver grey/White
RT 2 1/ 4 Cr 1 Mo (ER90S-B3)	TGS 2CM	Brown / Red
RT 347 (ER 347)	TGS – 347	Blue

(\* or other approved equivalents)

2.4.1.1 Where another set of colour code is followed, maintain a record of coding used

2.4.2 where the filter wire is cut, apply the appropriate colour code at both ends of the piece.

2.4.3 For other filler wires, a suitable colour distinct from table 1 shall be applied.

## BAKING AND HOLDING OF WELDING ELECTRODES

- 1.0 Purpose:
  - 1.1 This section details activities regarding baking and holding of welding electrodes used at sites.
- 2.0 Procedure:
  - 2.1 While handling, avoid contact of oil, grease with electrodes. Do not use oily or wet gloves.
    - 2.1.1 It is recommended that not more than two days requirements are baked.
  - 2.2 GTAW Filler Wires:
    - 2.2.1 These wires do not require any baking.
  - 2.3 Covered Electrodes:
    - 2.3.1 Baking and holding:
      - 2.3.1.1 Identify baking oven and holding oven.
      - 2.3.1.2 They shall have a temperature control facility upto 350<sup>0</sup>C for baking oven and 200 Deg. C for holding oven.
      - 2.3.1.3 A calibrated thermometer shall be provided for monitoring temperature.
    - 2.3.2 On opening a packet of electrodes, segregate and place them in the baking oven. Avoid mix up.
      - 2.3.2.1 After loading, raise the baking oven temperature to the desired range as per Table in 2.3.2.5.
      - 2.3.2.2 Note the time when the temperature reaches the desired range. Maintain this temperature for the duration required as per Table in 2.3.2.5.
      - 2.3.2.3 On completion of baking, transfer the electrodes to holding oven, maintain a minimum temperature of 100<sup>0</sup>C till issue.
      - 2.3.2.4 The electrode shall not be subjected to more than two cycles of baking.

2.3.2.5 Maintain a register containing following details :

- a) Brand name (e.g. Supratherme)
- b) Size (e.g Dia 4.0 mm)
- c) Quantity (e.g. 110 pieces)
- d) Time at required temperature ie. Above 250<sup>0</sup>C
- e) Time of Transfer to holding oven. Activities a,b,c to be recorded before loading into the oven.

### Baking and Holding Parameters

AWS Classification (*)	Baking		Holding Temperature <sup>0</sup> C (@)
	Temperature <sup>0</sup> C	Time (Hours)	
E7018	250 – 300	2	100 min
E7018-1	250 – 300	2	100 min
E7018-A1	250 – 300	2	100 min
E8018-B2	250 – 300	2	100 min
E9018-B3	250 – 300	2	100 min
E8018-B2L	250 – 300	2	100 min
E9018-B3L	250 – 300	2	100 min
E309 & E347	250 - 300	1	100 min

Note : (\*) For other electrodes, supplier's recommendations shall be followed.

(@) Maintain the temperature in the oven till issue.

2.3.2.6 After issue, maintain the electrodes in a portable oven at a minimum temperature of 65<sup>0</sup>C till use (not applicable for E6013, E309 & E347 electrodes).

2.3.3 Unused, returned electrodes shall be segregated and kept in the holding oven.

## **SELECTION AND ISSUE OF WELDING ELECTRODES / FILLER WIRES**

- 1.0 Purpose:
- 1.1 This procedure details methods for selection and issue of welding electrodes / filler wires for site operations.
- 2.0 Procedure:
- 2.1 Selection:
  - 2.1.1 The type of filler wire / electrode for welding shall be based on the details given in the contract documents like Erection Welding Schedules, drawings, Welding Procedure Specifications as supplied by the Manufacturing Units.
  - 2.1.2 Where not specified by the Manufacturing Units, selection shall be based on the tables enclosed.
  - 2.1.3 Where electrodes / filler wire are not covered in the documents mentioned in 2.1.1, 2.1.2, refer to manufacturing Units.
- 2.2. Issue:
  - 2.2.1 Issue of welding electrodes / filler wires shall be based on authorized Welding Electrodes Issue Voucher.
  - 2.2.2 It is recommended to restrict quantity issued to not more than 4 hours requirements.
  - 2.2.3 Redried low hydrogen electrodes shall be carried to the work spot in a portable oven.
  - 2.2.4 Maintain the temperature in the portable oven at the work spot above 65 Deg. C.
  - 2.2.5 Unused electrodes shall be returned and kept in the holding oven till reissue.

TABLE – 1 SELECTION OF GTAW FILLER WIRE, SMAW ELECTRODE  
FOR BUTT WELDS IN TUBES, PIPES, HEADERS

MATERIAL	WELDING PROCESS	P1 GROUP 1 P1 GROUP 2	P3 GROUP 1	P4 GROUP 1	P5 GROUP 1	P8	Cr Mov
P1 Group 1 P1 Group 2	GTAW SMAW	RT 1 / 2 Mo E7018 (ATT) Note – 1					
P3 Group 1	GTAW SMAW	RT 1 / 2 Mo E7018 (ATT)	RT 1 / 2 Mo E7018 A1				
P4 Group 1	GTAW SMAW	RT 1 / 2 Mo E7018 (ATT)	RT 1 / 2 Mo E7018 A1	RT 1 Cr 1/ 2 Mo E8018- B2			
P5 Group 1	GTAW SMAW	RT 1 / 2 Mo E7018 (ATT)	RT 1 / 2 Mo E7018 A1	RT 1 Cr 1/ 2 Mo E8018- B2	RT 2 1/ 4 Cr 1 Mo E9018 – B3		
PS	GTAW SMAW			ERMiCr3 ENiCrFe2	ERNiCr3 ENiCrFe2	RT347 E347	
Cr Mo V Note- 2	GTAW SMAW				RT 2 1/ 4 Cr 1 Mo E9018-B3		RT 2 1/ 4 Cr 1 Mo E9018- B3

Note – 1 E7018 - A1 For P1 Gr 2 + P1 Gr 2 and Dia > 127 mm.

Note – 2 DIN 14MoV63 or equivalent.

**TABLE – 2 SELECTION OF ELECTRODES  
FOR WELDING ATTACHMENTS TO TUBES**

TUBE MATERIAL	ATTACHMENT MATERIAL				
	P1 GROUP 1	P3 GROUP 1	P4 GROUP 1	PS GROUP 1	P8
P1 Group 1 P1 Group 2	E7018	E7018	E7018	E7018	E7018-A1
P3	E7018-A1	E7018-A1	E7018-A1	E7018-A1	E7018-A1
P4 Group 1	E8018-B2		E8018-B2	E8018-B2	E7018-A1
P5 Group 1	E9018-B3		E9018-B3	E9018-B3	E7018-A1
P8			E 309 Note – 1	E 309 Note - 1	E347

Note – 1 Used as circumferential attachment only.

**TABLE – 3 SELECTION OF ELECTRODES, PREHEAT, PWHT  
FOR ATTACHMENT TO ATTACHMENT WELDS**

(Seal bands, High crown bars, End bars,  
End bar lifting lugs and Collector plates etc.)

MATERIAL	WELDING REQUIREMENTS	P1	P4	P5	P8 GRUP 1	P8 GROUP 2
P1	Electrode Preheat PWHT	E7018 Nil Nil				
P4	Electrode Preheat PWHT	E7018 (Note-2) Nil (Note – 2) Nil (Note – 2)	E8018-B2 Nil Nil			
P5	Electrode Preheat PWHT	E7018 Note 1 & 2 Nil (Note-2)	E8018-B2 Note-1 Nil	E9018-B3 Note-1 Nil		
P8	Electrode Preheat PWHT	E309 Nil Nil	E309 Nil Nil	E309 Nil Nil	E347 Nil Nil	E309 Nil Nil

- Note : 1. When P5 material thickness is more than 10mm, 150 Deg.C preheat is required.  
2. Electrode, Preheat and PWHT requirement for welding end bar lifting lug are as follows:

END BAR LIFTING LUG	END BAR	ELECTRODE	PREHEAT DEG.C	PWHT DEG.C
P1	P4	E8018-B2	120	650 – 680
P1	P5	E9018-B3	150	680-720

**TABLE – 4 SELECTION OF ELECTRODES FOR WELDING NOZZLE ATTACHMENTS,  
HANDHOLE PLATE, RG PLUG ETC TO HEADERS, PIPES**

HEADER, PIPE MATERIAL	ATTACHMENT MATERIAL				
	P1	P3	P4	P5	P8
P1	E7018 (ATT)	-	E7018 (ATT)	-	ENiCrFe2
P4	-	-	E8018-B2	E8018-B2	-
P5	-	-	-	E9018-B3	ENiCrFe2
Cr Mo V Note-1	-	-	-	E9018-B3	ENiCrFe2

**TABLE – 5 SELECTION OF ELECTRODES FOR NON-PRESSURE PARTS  
(INCLUDING STRUCTURES)**

MATERIAL	ELECTRODES
P1 + P1      Carton Steel + P1  Carton + Carton Steel     Steel	a. For butt welds, upto 6mm including     : E6013
	Over 6 mm     : E7018
	b. For fillets, upto 8 mm including     : E6013
	Over 8 mm     : E7018
	E6013 or E7018
	E8018-B2

## **WELDER QUALIFICATION**

1.0 Scope:

1.1 This chapter details the procedure for qualification of welder at site.

2.0 Contents:

1. Qualification of Welders at Site.
2. Table-1 – Welder qualification Requirements.
3. Record of Welder Performance Qualification Tests.
4. Figure- 1 Fillet Weld Break Specimen.  
Figure-2 Method of Rupturing.  
Figure-3 Positions.  
Figure-4 Plate Butt Weld specimen.  
Figure-5 Pipe Butt Weld Specimen.  
Figure-6 Bend Specimen.  
Figure-7 Bend Jig.

## QUALIFICATION OF WELDERS AT SITES

- 1.0 Base Metal:
  - 1.1 For selection refer tables in chapter II.
- 2.0 Test coupon:
  - 2.1 Depending on the range to be qualified, choose the appropriate test coupon from table-1.
  - 2.2 For plate butt welds, details of edge preparation shall be as per Figure-4.
  - 2.3 For pipe butt welds, details of edge preparation shall be as per Figure-5.
  - 2.4 For structural tack welds, refer Figure-1.
- 3.0 Requirement of Tests:
  - 3.1 For Structural Tack Welders:
    - 3.1.1 Break Test as per Figure-2.
  - 3.2 For Plate Butt Welds:
    - 3.2.1 Minimum of 2 specimens for bend test; one for root bend and other for face bend. Width of specimen shall be 38 mm for plate thickness upto 9.5 mm. For thickness greater than 9.5 mm, width of specimens shall be 10 mm and they shall be side bend tested.
  - 3.3 For Pipe Welder:
    - 3.3.1 The order of removal of test specimens shall be as per Figure-6.

3.3.2 For width and number of bend specimens, refer table below:

TABLE

OD	W	No. of Bend Specimens		
		Face	Root	Side
> 101.6	38.0	2	2	(**)
50.8 – 101.6	19.0	2	2	(**)
< 50.8	9.5	2	2	(**)
<= 25.4	(+ +)	2	2	-

(\*\*) for thickness greater than 9.5 mm, side bend test of width 9.5 mm may be substituted.

(++) Cut into 4 equal sections (with allowance for saw cuts or machine cutting); sharp corners to be rounded off.

OD Outer diameter of pipe in mm

W Width of bend test specimen in mm

3.4 For bend jig refer Figure-7, for thickness of bend specimen 9.5 mm; for other thicknesses (t) the dimension shall be as below:

$$A = 4t$$

$$B = 2t$$

$$C = 6t + 3.2 \text{ mm}$$

$$D = 3t + 1.6 \text{ mm}$$

The above values are nominal.

3.5 Radiographic examination of test welds may be carried out in lieu of bend tests. Procedure and acceptance criteria are as per NDE Manual.

4.0 Essential Variables:

4.1 Changes to the following variables require requalification.

4.1.1 Process:

Example: Change from GTAW to SMAW or vice versa.

4.1.2 Joint:

A Change from one type of bevel to another.

Example: vee bevel to u bevel.

4.1.3 Base Metal:

A change in thickness or pipe diameter beyond the limits prescribed in Table-1.

4.1.4 Filler Metal:

A change from one F number to another F number, except as specified in table-1,

4.1.5 Positions:

Note: This procedure envisages qualification of welders to perform in all positions. Deviation to this are not recommended.

4.1.6 Gas:

Note: This procedure envisages test to pre-prescribed gas as for production welds.  
Deviation to this are not recommended.

4.1.7 Electrical Characteristics:

- a. AC to DC and vice versa.
- b. In DC, DCEN (Electrode Negative) to DCEP (Electrode Positive) and vice versa.

4.1.8 Technique:

Note:- This procedure envisages only use of uphill progression technique.

5.0 Acceptance Criteria:

5.1 Structural Tack Welding:

5.1.1 No cracks.

5.1.2 No lack of fusion.

5.1.3 Undercut not exceeding 1 mm.

5.1.4 Not more than 1 porosity (max. diameter of porosity 2 mm).

5.2 Plate / pipe Welding:

5.2.1 Visual Inspection:

- a. No cracks.
- b. No lack of fusion or incomplete penetration.
- c. Not more than 1 porosity in a length of 100 mm of length of weld (max. porosity diameter 2 mm).

5.2.2 Bend Test results:

The convex surface of the bend test specimen shall be visually examined for surface discontinuities. For acceptance, the surface shall contain no discontinuities exceeding the following dimensions.

1. 3 mm measured in any direction on the surface.
2. The sum of the greatest dimensions of all discontinuities exceeding 1 mm but less than or equal to 3 mm, shall not exceed 10 mm.
3. The maximum corner crack of 6 mm, except when that corner crack resulted from visible slag inclusion or other fusion type discontinuities, then the 3 mm maximum shall apply. Specimens with corner cracks exceeding 6 mm with no evidence of slag inclusions or other fusion type discontinuities shall be disregarded, and a replacement test specimen from the original weldment shall be tested.

6.0 Retests :

6.1 A welder who fails to meet the acceptance criteria for one or more test specimens, may be retested as per this procedure after adequate practice.

7.0 Validity :

7.1 When a welder meets the requirements of this procedure, the validity will be for a maximum of 2 years from the date of test, limited to Validity specified by statutory authority, as applicable.

7.2 The validity may be extended by one year each time, based on satisfactory performance.

8.0 Requalification :

8.1 Requalification is required for the following :

- a. Where there is a specific reason to doubt the skill of the welder.
- b. Due to non-engagement of the welder for a continuous period of 6 months.

9.0 Records ;

9.1 The welding in charge at site shall maintain the following records.

- A. Record of welder performance Qualification Test (as per format).
- B. Register of qualified welders (employer-wise) containing the following details :
  - 1. Name of welder.
  - 2. Age.
  - 3. Tested for pipe / plate / tack.
  - 4. Performance Test No.
  - 5. Validity.
  - 6. Welder Code.
  - 7. Remarks.

The above register shall be updated for deletions also.

9.2 Copies of welder identity card (including details as in 9.1 B and relevant variables qualified).

9.3 Pertinent radiography reports.

10.0 Enclosures :

- 1. Table – 1 - Welder qualification Requirements.
- 2. Record of Welder Performance Qualification Test.
- 3. Figure-1 - Structural Tack weld specimen.
- 4. Figure – 2 - Break Test.
- 5. Figure – 3 – Weld Positions.
- 6. Figure – 4 - Plate Butt Weld Specimen.
- 7. Figure – 5 - Pipe Butt Weld Specimen.
- 8. Figure – 6 - Order of Removal of Test Specimen.
- 9. Figure – 7 - Bend Jig

**WELDER'S QUALIFICATION REQUIREMENTS**

**TABLE - 1**

S L. N O	TEST FOR	BASE METAL Note -1	TEST COUPON DIMENSION OD, t	ELECTRODE TO BE USED Note 2.4	WELD POSITIONS	REFEREN CE FIGURE	RANGE QUALIFIED DIA. & T	POSI TION QUA LIFI ED	ELECTROD E QUALIFIED Note 2,4 REMARKS	
1.	Structural Tack	P1 Gr1	t=10 mm OR 12 mm	(E 6013 F2)	3F & 4F	Fig. 1 & 2	T = Unlimited	ALL	F2, F1	Refer Fig.1,3
				(E 7018 ) F4	3F & 4F	-do-	T = Unlimited	ALL	F4 & Below	
2.	Plate Welder (Structural)	-do-	t>=>25 mm	F4	3G & 4G	Fig . 3	T=>3.2 mm	ALL	F4 & Below	
			t>25 mm	F4	3G & 4G	-do-	T>3.2 mm <=2t	ALL	F4 & Below	
3.	Plate Welder (Other than Structural)	-do-	t>=>25 mm	F4	2G 3G & 4G	-do-	T = Unlimited OD=>600 mm	ALL	F4 & Below	
			t>25 mm	F4	2G 3G & 4G	-do-	T<=2t OD=>600 mm	ALL	F4 & Below	
4.	Pipe Welder	-do-	OD=>25 mm	F4	6G	-do-	OD=> Above	ALL	F4 & Below	
			OD=>25 mm & <=73 mm	F4	6G	-do-	OD & 25 mm	ALL	F4 & Below	
			OD>=73 mm	F4	6G	-do-	OD>73 mm T <=2t	ALL ALL	F4 & Below F4 & Below	
			t<19 mm	F4	6G	-do-	T= Unlimited	ALL	F4 & Below	
			t.>=19 mm	F4	6G	-do-				

TACK WELDER QUALIFICATION

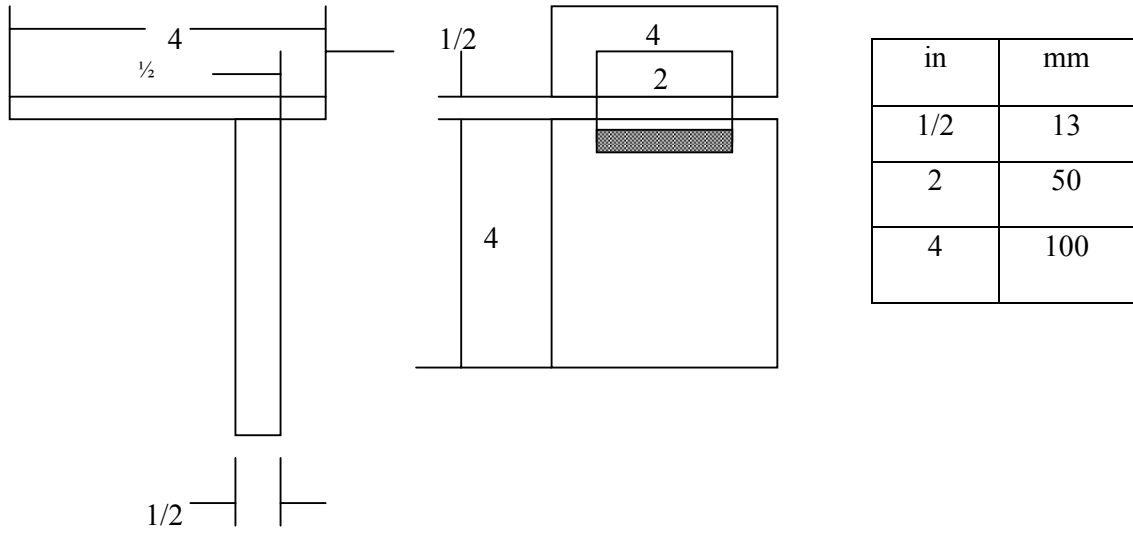

Fig 1 – Fillet Weld Break specimen

FORCE

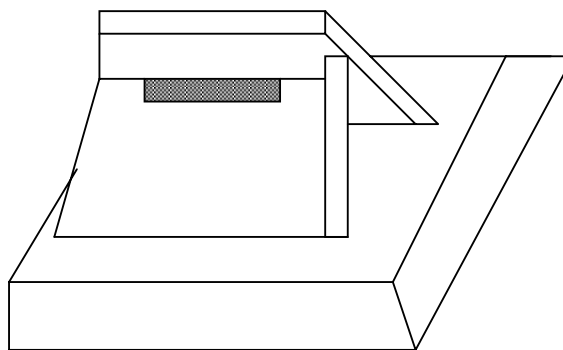
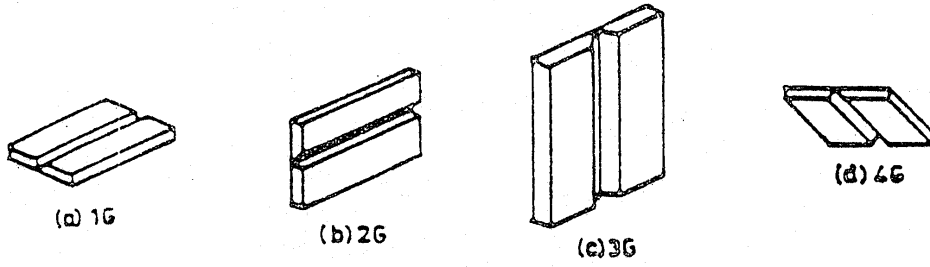
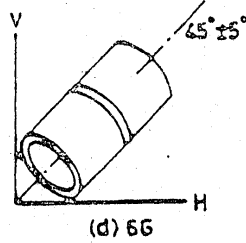
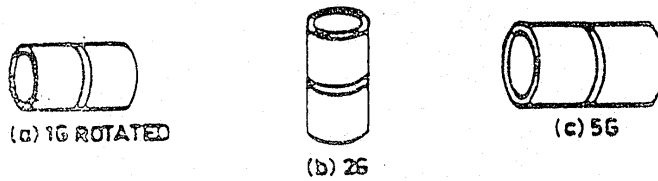

Fig – 2 – Method of Rupturing

Fig. 3 - POSITIONS



GROOVE WELDS IN PLATE



GROOVE WELDS IN PIPE

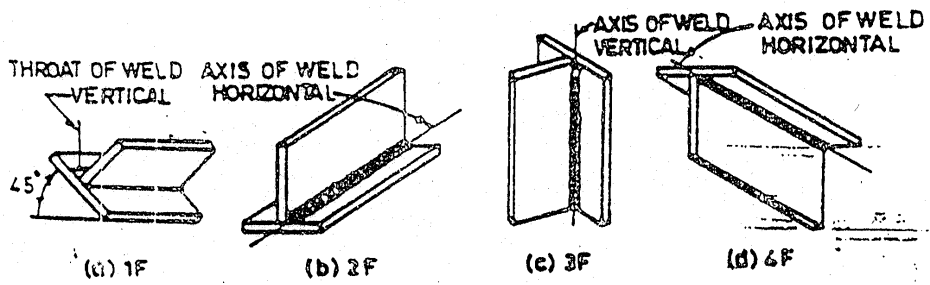

FILLET WELDS PLATE

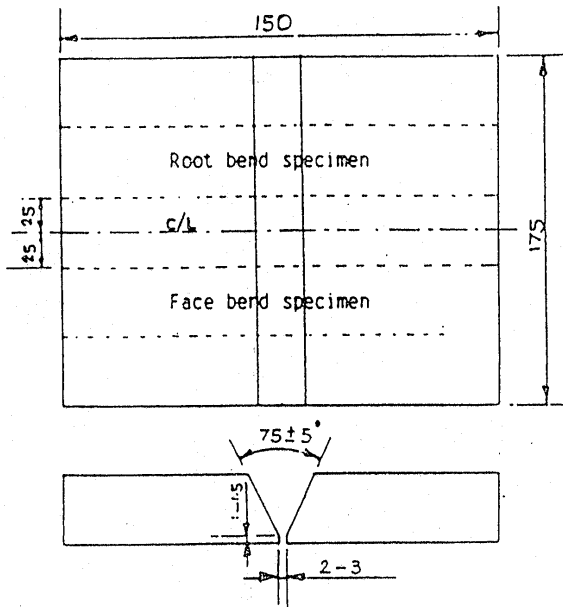
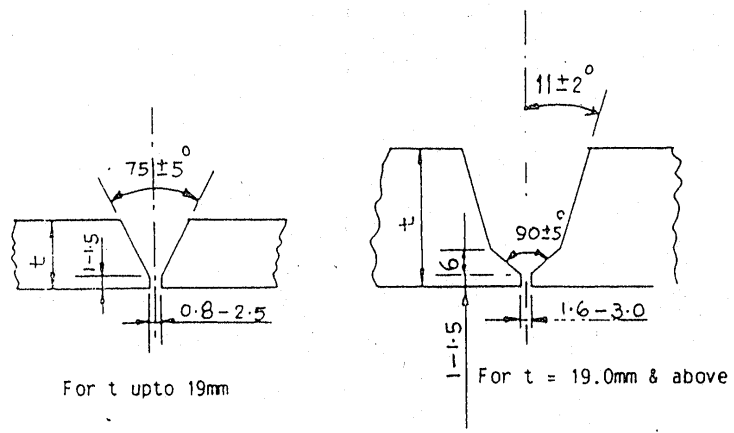
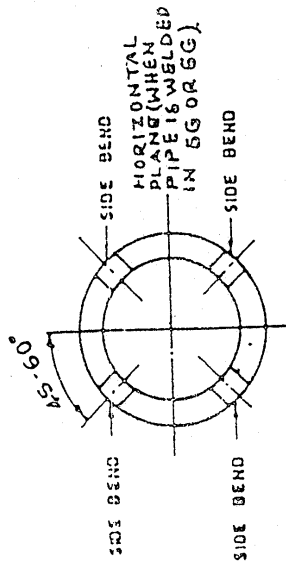

Fig.4: Plate Butt Weld Specimen



All dimensions in mm

Fig.5: Pipe Butt Weld Specimen



PIPE TEST COUPON

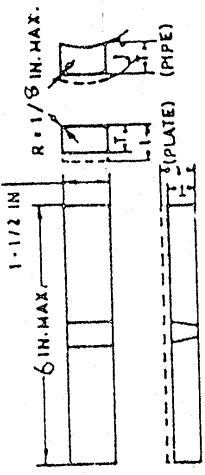

ROOT BEND SPECIMEN - PLATE AND PIPE

1/8" APPROX.

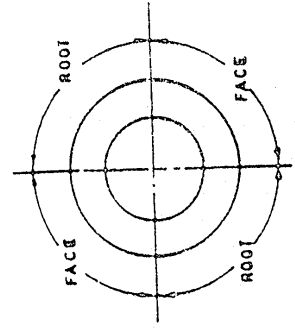
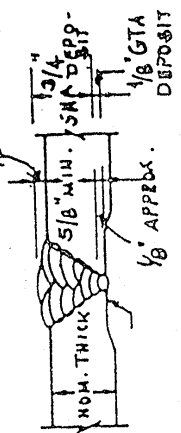

PIPE TEST COUPON

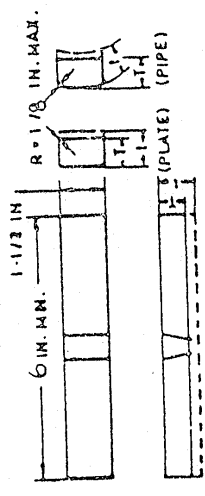

FACE BEND SPECIMEN - PLATE AND PIPE

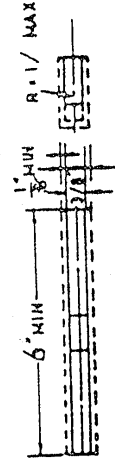

SIDE BEND

Figure - 6



**RECORD OF WELDER PERFORMANCE QUALIFICATION TEST**

**Performance Test No.,  
Date :**

Site :  
**Welder's Name & Address :**

**Welder Code :**

Material groupings permitted :  
Thickness Qualified :  
(This performance test is as per  
Procedure No.

Welding Processes :  
Position(s) Qualified :  
Dia Qualified :

**TEST MATERIAL**

Specification :  
Thickness (and Dia. Of Pipe) :  
Shielding Gas(es)

Filler Metal :  
SFA No. :  
AWS Classification :

**PROCESS VARIABLES**

Position of test weld :

Current :

Polarity :

Pre-heat temp ;  
Test joints

inter Pass Temp:

Post-heat Temp :

Test Results

Type Bend

Results

Type Bend

Results

Type Bend

Results

Type Bend

Results

Radiography Ref. & Results :

(Sketch )

Welder's signature

Agency Conducting Test

We certify that the statements in this record are correct and that the test weld were prepared, welded and tested in accordance with requirements.

This is valid upto -----

Welding In-charge / BHEL.

## INSPECTION OF WELDING

### 1.0 Purpose :

This procedure provides details for performing visual inspection of weld fit-ups, welding in progress and completed welds.

### 2.0 Reference :

#### 2.1 Contract drawings

#### 2.2 Erection welding schedule (supplied by Units) or equivalent.

#### 2.3 Welding procedure specification, where supplied.

#### 2.4 Indian Boiler Regulations (for boilers erected in India).

### 3.0 General Requirements :

#### 3.1 Ensure that the components to be welded are in accordance with the contract drawings, Welding Schedule and other relevant documents.

#### 3.2 The condition of welded Surfaces to be inspected must be clean and dry.

#### 3.3 There shall be sufficient lighting to allow proper interpretation of visual inspection.

### 4.0 Weld fit-up Inspection :

#### 4.1 The surface to be welded shall be smooth and free from deep notches, irregularities, scale, rust, oil, grease and other foreign materials.

#### 4.2 Piping, tubing and headers to be jointed shall be aligned within allowable tolerances on diameters, wall thicknesses and out-of-roundness as below:

#### **Maximum Permissible out-of-alignment at bore**

Bore (mm)	Max. Misalignment (mm)	
	For GTAW	For SMAW
Upto 100	1.0	1.0
Over 100 to 300	1.6	1.6
Over 300	1.6	2.4

- 4.3 When fit, components to be welded shall not show an appreciable off-set or misalignment when viewed from positions apart.
- 4.4 The root opening of components to be joined shall be adequate to provide acceptable penetration.
- 4.5 On fillet welds, the parts to be jointed shall be brought as close to contact as practical, although in most instances a small opening between the parts is desirable.
- 4.6 Root gaps should be maintained at 1.6 mm – 2.4 mm (refer relevant document).
- 4.7 Weld area should be protected from drafts and wind, to maintain inert gas shield.
- 5.0 Checks during welding operation:
  - 5.1 Ensure the required minimum preheat temperature is applied and established during welding.
  - 5.2 Ensure correct electrode / filler metal is used for welding.
  - 5.3 Tack welds are examined by the welder before they are incorporated in the final weld.
  - 5.4 Ensure proper drying / holding of electrodes prior to use.
  - 5.5 Ensure the correct interpass temperature is maintained.
  - 5.6 Ensure proper cleaning of weld between beads.
- 6.0 Checks on the completed weld:
  - 6.1 No visible cracks, pin-holes or incomplete fusion.
  - 6.2 The weld surface must be sufficiently free of coarse ripples, grooves, overlaps, abrupt ridges and valleys, visible slag inclusions, porosity and adjacent starts and stops.
  - 6.3 Undercuts not to exceed 1 mm.
  - 6.4 Where inside surface is readily accessible, the same shall be inspected for excess penetration and root concavity. The permissible limits are given below.

Root concavity: max of 2.5 mm or 20% of thickness at weld, whichever is lesser, provided adequate reinforcement is present.

Excess penetration: upto and including 3.2 mm.

- 6.5 For plate butt welds, the weld reinforcement should not exceed 3.2 mm.
- 6.6 For circumferential joints in piping and tubing the maximum weld reinforcements permitted are given below:

#### Maximum Permissible Reinforcements

Thickness of of base metal	For service above 400 Deg.C	Temperature upto & incl. 400 Deg.C
Upto 3.2	1.6	2.4
Over 3.2 – 4.	1.6	3.2
Over 4.8 – 12.7	2.4	4.0
Over 12.7 – 25.4	3.2	4.8
Over 25.4	4.0	6.3

All Dimensons in mm

- 6.7 There shall be no overlaps.
- The faces of fillet welds are not excessively convex or concave and the weld legs are of the proper length.
- 6.8 In case of weld joints in pressure parts and joints like ceiling girder, the weld joint must be suitably identified.

## **WELDER PERFORMANCE MONITORING**

- 1.0 Purpose:
- 1.1 This procedure deals with monitoring the performance of welders engaged at sites. This procedure is applicable where radiography is performed.
- 2.0 Procedure:
- 2.1 The welder performance shall be monitored on a calendar month basis.
- 2.2. Extent of radiography shall be representative of weekly outputs of the welder.
- 2.3 Quantum of radiography shall be as per contractual requirements.
- 2.4 Evaluation of welds radiographed shall be as per NDE manual or other documents as specifically applicable.
- 2.5 Welder performance evaluation:
  - 2.5.1 For welds dia 88.9 mm and below:
    - 2.5.1.1. The percentage defectives (repairable) is calculated as a percentage of number of unaccepted to those radiographed.
    - 2.5.1.2 Upto and including 5% defectives performance is satisfactory else unsatisfactory.
  - 2.5.2 For welds over dia 88.9 mm and plate welds:
    - 2.5.2.1 The percentage defectives is calculated as a percentage of length of defectives repairable to the length radiographed.
    - 2.5.2.2 Upto an including 2.5% defectives performance is satisfactory else unsatisfactory.
- 2.6 When a welder gives unsatisfactory performance for a continuous period of 3 months he shall be requalified
  - 2.6.1 Requalification of welder shall be called for when there is a specific reason to question his ability to make acceptable welds. This shall override requirements of cl.2.6
- 2.7 Welds produced during any month shall be radiographed and evaluated latest by 10<sup>th</sup> of the succeeding month.

2.7.1 Under circumstances when cl.2.7 is not satisfied for any particular welder, he may be disengaged from the job till such time his performance can be evaluated for the month in study.

2.7.2 Site in-charge may waive the restriction imposed in 2.7.1 reviewing the situations for non-compliance of cl.2.7 and may allow engagement of the welder in question for a period not exceeding one successive month to the month in study.

### **3.0 Records:**

3.1 Welding in-charge shall prepare and maintain Welder Performance Records, welderwise.

## REPAIR WELDING

- 1.0 Purpose:
- 1.1 This procedure details steps to be taken for weld repairs.
- 2.0 Procedure:
- 2.1 Unacceptable welds, based on visual inspection or NDE, shall be repaired.
- 2.2 Removal of Defects:
  - 2.2.1 The identified defect area shall be marked on the part.
  - 2.2.2 The defects may be removed by grinding / thermal gouging.
    - 2.2.2.1 Where thermal gouging is done, adopt the requirements of preheating as detailed in Heat Treatment Manual.
    - 2.2.2.2 However, only grinding is permitted for the last 6 mm from the root.
- 2.3 Removal of defects shall be verified by visual inspection PT, MT, RT as appropriate.
- 2.4 The profile of ground portion shall be smooth and wide enough to permit proper fusion during repair welding.
- 2.5 Repair welding shall be carried out as per the procedure for the initial weld.
- 2.6 Repair weld shall undergo the same type of NDE as the initial weld.
- 2.7 Repeat steps 2.1 to 2.6 till acceptable weld is made.
- 2.8 Where cutting, re-edge preparation and re-welding the joint will yield better results, the same shall be followed.
- 3.0 Where a specific repair procedure is supplied by the Manufacturing Unit, the same shall be followed.
- 4.0 Records:
  - 4.1 Records pertaining to the repairs like Welder, NDE records shall be maintained

## APPENDIX A

Recommended Electrical Characteristics for Welding at Sites.

Electrical Classification	Process	Dia mm	Current		Voltage range
			Type	Amp range	
&&	GTAW	2.5	DCEN	70-120	12-20
		3.15	DCEN	110-160	12-20
E6013	SMAW	2.5	DCEP	50-100	18-26
		3.15	DCEP	90-140	18-26
		4.0	DCEP	130-190	18-26
@@ EXX18	SMAW	2.5	DCEP	70-120	18-26
		3.15	DCEP	100-160	18-26
		4.0	DCEP	150-220	18-26
## EXXX	SMAW	2.5	DCEP	70-100	18-26
		3.15	DCEP	100-140	18-26
		4.0	DCEP	120-170	18-26

Notes:

&& - The current ranges are applicable for all filler materials used in GTAW process

@@ - EXX18 include E7018, E7018-1, E7018-A1, E8018 B2, E9018 B3.

## - EXXX include E309, E347 electrodes.

## **APPENDIX – B**

Extract from AWS D 1.1. 1992

### **SAFE PRACTICES (Non-mandatory Information)**

(This Appendix is not a part of ANSI/AWS D1.1-92, Structural Welding Code-Steel, but is included for information purposes only)

This appendix covers many of the basic elements of safety general to arc welding processes. It includes many, but not all of the safety aspects related to structural welding. The hazards that may be encountered and the practices that will minimize personal injury and property damage are reviewed here.

#### **J1 Electrical Hazards**

Electric shock can kill. However, it can be avoided. Live electrical parts should not be touched. Read and understand the manufacturer's instructions and recommended safe practices. Faulty installation, improper grounding, and incorrect operation and maintenance of electrical equipment are all sources of danger.

All electrical equipment and the work pieces should be grounded. A separate connection is required to ground the workpiece. The work lead should not be mistaken for a ground connection.

To prevent shock, the work area, equipment, and clothing should be kept dry at all times. Dry gloves and rubber soled shoes should be worn. The welder should stand on a dry board or insulated platform.

Cables and connectors should be kept in good condition. Worn, damaged, or bare cables should not be used. In case of electric shock, the power should be turned off immediately. If the rescuer must resort to pulling the victim from the live contact, nonconducting materials should be used. A physician should be called and CPR continued until breathing has been restored, or until a physician has arrived. See references 8,7 and 10

#### **J2 Fumes and Gases**

Many welding, cutting and allied processes produce fumes and gases which may be harmful to one's health. Fumes and solid particles originate from welding consumables, the base metal, and any coating present on the base metal. Gases are produced during the welding process or may be produced by the effects of process radiation on the surrounding environment. Everyone associated with the welding operation should acquaint themselves with the effects of these fumes and gases.

The possible effects of over-exposure to fumes and gases range from irritation of eyes, skin and respiratory system to more severe complications. Effects may occur immediately or at some later time. Fumes can cause symptoms such as nausea, headaches, dizziness, and metal fumes fever. Sufficient ventilation, exhaust at the arc, or both, should be used to keep fumes and gases from breathing zones and the general work area.

For more detailed information on fumes and gases produced by the various welding processes, see References 1,4 and 11

### J3 Noise

Excessive noise is a known health hazard. Exposure to excessive noise can cause a loss of hearing. This loss of hearing can be either full or partial, and temporary or permanent. Excessive noise adversely affects hearing capability. In addition, there is evidence that excessive noise affects other bodily functions and behavior. Personal protective devices such as ear muffs or ear plugs may be employed. Generally, these devices are only accepted when engineering controls are not fully effective. See References 1,5 and 11.

### J4 Burn Protection

Molten metal, sparks, slag, and hot work surfaces are produced by welding, cutting and allied process. These can cause burns if precautionary measures are not used.

Workers should wear protective clothing made of fire resistant material. Pant cuffs or clothing with open pockets or other places on clothing that can catch and retain molten metal or sparks should not be worn. High top shoes or leather leggings and fire resistant gloves should be worn. Pant legs should be worn over the outside of high top boots. Helmets or hand shields that provide protection for the face, neck, and ears, should be worn, as well as head covering to protect. Clothing should be kept free of grease and oil. Combustible materials should not be carried in pockets. If any combustible substance is spilled on clothing it should be replaced with fire resistant clothing before working with open arcs or flame.

Appropriate eye protection should be used at all times. Goggles or equivalent also should be worn to give added eye protection.

Insulated gloves protection should be worn at all times when in contact with hot items or handling electrical equipment.

For more detailed information on personnel protection Reference 2,3,8 and 11 should be consulted.

## J5 Fire Prevention

Molten metal, sparks, slag, and hot work surfaces are produced by welding, cutting, and allied processes. These can cause fire or explosion if precautionary measures are not used.

Explosions have occurred where welding or cutting has been performed in spaces containing flammable gases, vapours, liquid, or dust. All combustible material should be removed from the work area. Where possible, move the work to a location well away from combustible materials. If neither action is possible, combustibles should be protected with a cover or fire resistant material. All combustible materials should be removed or safely protected within a radius of 35 ft. (11m) around the work area.

Welding or cutting should not be done in atmospheres containing dangerously reactive or flammable gases, vapours, liquid, or dust. Heat should not be applied to a container that has held an unknown substance or a combustible material whose contents when heated can produce flammable or explosive vapours. Adequate ventilation should be provided in work areas to prevent accumulation of flammable gases, vapours or dusts. Containers should be cleaned and purged before applying heat.

For more detailed information on fire hazards from welding and cutting operations, see References 6,8,9 and 11

## J6 Radiation

Welding, cutting and allied operations may produce radiant energy (radiation) harmful to health. Everyone should acquaint themselves with the effects of this radiant energy.

Radiant energy may be ionizing (such as X-rays) or non-ionizing (such as ultraviolet, visible light, or infrared). Radiation can produce a variety of effects such as skin burns and eye damage, if excessive exposure occurs.

Some processes such as resistance welding and cold pressure welding ordinarily produce negligible quantities of radiant energy. However, most arc welding and cutting processes (except submerged arc when used properly), laser welding and torch welding, cutting, brazing, or soldering can produce quantities of non-ionizing radiation such that precautionary measures are necessary.

Protection from possible harmful radiation effects include the following:

- 1) Welding arcs should not be viewed except through welding filter plates (see Reference 2)
- 2) Transparent welding curtains are-not intended as welding filter plates, but rather, are intended to protect passers by from incidental exposure.

- 3) Exposed skin should be protected with adequate gloves and clothing as specified. See Reference 8.
- 4) The casual passerby to welding operations should be protected by the use of screens, curtains, or adequate distance from aisles, walkways, etc.
- 5) Safety glasses with ultraviolet protective side shields have been shown to provide some beneficial protection from ultraviolet radiation produced by welding arcs.

#### References Cited

1. American Conference of Governmental Industry Hygienist (ACGIH). Threshold limit values for chemical substances and physical agents in the workroom environment, Cincinnati, Ohio; American Conference of Governmental Industry Hygienists(ACGIH)
2. American National Standards Institute. Practice for occupational and educational eye and face protection, ANSI Z87.1 New York: American National Standards Institute.
3. -----Safety-toe footwear, ANSI Z41.1 New York: American National Standards Institute.
4. -----American Welding Society. Fumes and gases in the welding environment, AWS Report. Miami, Florida: American Welding Society.
5. -----Method for sound level measurement of manual arc welding and cutting processes, ANSI / AWS F6.1. Miami, Florida.
6. -----Recommended safe practices for the preparation for welding and cutting containers that have held hazardous substances, ANSI/AWS F4.1. Miami, Florida: American Welding Society.
7. -----Safe Practices.(Reprint from Welding Handbook, Volume 1, Eight Edition) Miami, Florida: American welding Society.
8. ----- Safety in welding and cutting, ANSI/ASC Z49.1 Miami, Florida: American Welding, society.
9. National Fire Protection Association: Cutting and welding processes NFPA Standard 51B. Quincy, Massachusetts: National Fire Protection Association
10. ----- National Electrical Code. NFPA No.70.Quincy, Massachusetts National Fire Protection Association.
11. Occupational Safety and Health Administration. Code of Federal Regulations, Title 20 Labour, Chapter XVII, Part 1910; OSHA General Industry Standards. Washington, DC:U.S Government Printing Office.

## APPENDIX A

### MINIMUM REQUIREMENTS OF NDE AS PER IBR

(Quantum of Radiography or other approved NDE methods for Butt Welds)

1.0 Boiler and Superheater Tubes (Regulation No.151 (h):

BORE, MM	PERCENTAGE OF NDE
OVER 178	100%
OVER 102 AND UPTO 178 INCLUDING	10% (MIN. 2 WELDS PER WELDER)
BELOW 102	5% (MIN 1 WELD PER WELDER)

2.0 Steam pipes and fittings (Regulation No.360 (d) – NDE Requirements:

2.1 Pipelines NDE requirement:

DESCRIPTION	BORE mm	PERCENTAGE OF NDE FOR EACH WELDER	PERCENTAGE OF CUTOUT JOINTS FOR VISUAL AND BEND TEST FOR EACH WELDER
CLASS I PIPELINES: A. WHERE THE COMPLETED PIPELINES ARE NOT SUBJECTED TO HYDRAULIC TEST	OVER 102	100%	—
	OVER 38 AND UPTO 102 INCLUDING BELOW 38	5% (MIN. 2 WELDS PER WELDER)	2% (Note.1)
B:WHERE THE COMPLETED PIPELINES ARE SUBJECTED TO HYDRAULIC TEST	OVER 102	10% (MIN. 2 WELDS PER WELDER)	—
	OVER 38 AND UPTO 102 INCLUDING BELOW 38 mm	2% (MIN 1 WELD PER WELDER)	2% (Note.1)
CLASS II PIPELINES: ALL PIPES	ALL SIZE	—	2% (Note –1)

Note. 1: It is suggested that in lieu of this radiography may be substituted at sites.

2.2 Retest:

If any test specimen is unsatisfactory, two further weld specimen for retest shall be selected from the production welds and subjected to tests.

## APPENDIX B

Extract from ASME/ ANSI B 31.1/1992 MANDATORY MINIMUM NDE for pressure welds or welds to pressure retaining components.

- I. Piping service conditions temperature over 400 deg C and all pressures.

Type of weld	NDE
Butt welds	RT for over NPS 50 MT-& PT for NPS 50 And less
Fillet, Socket, attachment & seal welds	MT or PT for all sizes and Thicknesses

- II Piping service conditions: Temperatures between 175 deg C Inclusive and 400 deg C inclusive with all pressures above 7100 kPa(gauge)

Type of weld	NDE
Butt welds	RT for over NPS 50 with Thickness over 19 mm. Visual For others.
Fillet, socket, attachment and seal weld	Visual for all sizes & Thicknesses.

- III All others : Visual examination.

NOTES: 1) NPS - nominal pipe size

- 2) All welds must be given a visual examination in addition to the NDE specified.
- 3) The thickness of buttwelds is defined as the thicker of the two abutting ends after end preparation
- 4) Temperatures and pressures shown are design.
- 5) Fillet welds not exceeding 6 mm throat thickness which are used for the permanent attachment of nonpressure retaining parts are exempt from the PT & MT requirements.

## APPENDIX C

### NDE Requirements as per ASME Sec – I

Following butt welds shall be radiographed or ultrasonically tested.

- A. For drums, shells excluding pipes, tubes, headers.
  - I NPS exceeding 250 mm or wall thickness greater than 28 mm. Bring against ( B. For pipes, tubes and headers. Radiography is not mandatory for the following conditions.)
    1. For parts containing steam: NPS  $\leq$  400 mm or wall thickness  $\leq$  40 mm
    2. For parts containing water : NPS  $\leq$  250 mm or wall thickness  $\leq$  28 mm
    3. For parts in flue gas path but not subject to radiation: NPS  $\leq$  150 mm or wall thickness  $\leq$  19 mm
    4. For parts in flue gas path and subject to radiation: NPS  $\leq$  100 mm or wall thickness  $\leq$  12.5 mm
  - II Where radiography is to be performed and geometric unsharpness cannot be within 1.8 mm, ultrasonic testing shall be performed.

Note: NPS – nominated pipe size

## HEAT TREATMENT

1.0 Purpose:

1.1 This procedure provides information, method and control for preheat (PH) and post weld heat treatment (PWHT) of welds at sites.

2.0 Document:

2.1 The following documents are referred in preparation of this procedure.

2.1.1 ASME Sec.1, II(a)

2.1.2 ANSI B 31.1

2.1.3 Indian Boiler Regulations

2.1.4 AWS D1.1/Steel

2.1.5 Welding Manual – PS:CMX:001:00:93

2.2 The following are referred to as Primary Documents

- Erection Welding Schedules or equivalent
- Contract Drawings
- Plant Standards, where supplied
- Welding Procedure Specification, where supplied

2.2.1 Where parameter for Preheating (PH) and PWHT are not available in the primary documents reference may be made to this manual.

2.2.2 Where such parameters are not contained either in the primary documents or in this manual reference may be made to Manufacturing Units.

3.0 Procedure:

3.1 Preheating:

3.1.1 When parts of two different thicknesses are welded together, the preheating requirements of the thicker shall rule.

3.1.2 When parts of two different P numbers are jointed together, the material requiring higher preheat shall govern (Please refer Welding Manual for P numbers)

3.1.3 Preheating shall be checked using thermal chalk (temperature indicating crayons) prior to start-up welding as well as at frequent intervals during welding. It is preferable to have a thermocouple and a temperature recorder in case of alloy steels of thickness greater than 50 mm.

3.1.4 In case of any interruption during welding, preheating temperature shall be maintained at joint by wrapping in dry thermal insulating blankets to ensure slow and uniform cooling.

3.1.5 Preheating Methods:

3.1.5.1 Preheating shall be applied by any of the methods given below:

- a. Electrical Resistance Heaters
- b. Induction Heating
- c. Oxy-Acetylene or other Gas Torches

3.2 Post Weld Heat Treatment(PWHT):

3.2.1 The method shall be by locally heating a circumferential band including the entire weld and adjacent area of base metal, by Induction or Electrical Resistance Heating.

3.2.2 Heat Band for PWHT

3.2.2.1 For Boilers:

- a. When heat treating welded joints in components in the boiler, proper width of the heated circumferential band on either side of the weld.

(W) must be as,  $W = 3$  times the width of the widest part of the weld groove but in no case, less than twice the width of weld at reinforcement.

- b. When used in post weld heat treatment in sections –  $W = 3$  times the plate thickness.

- c. For nozzle and other welded attachments –  $W =$  must be wider than the nozzle or attachment or 3 times the wall thickness.

3.2.2.2 For Piping:

$W =$  Three times the wall thickness of thickest part, in case of nozzles and attachment welds, the width of the heat band shall extend beyond the nozzle or the attachment wall on each side by at least twice the higher thickness and shall extend completely around the header.

## AMENDMENT NO : 1

### 3.2.2.3 Other Pressure Vessels:

Heat band width, placement of thermocouple and preheat and PWHT information shall be obtained from the supplier.

### 3.3 Condition of Welded Joints:

3.3.1 The weldment shall be free of grease, oil etc, prior to PH/PWHT.

### 3.4 Temperature Measurement for PWHT:

3.4.1 Post weld heat treatment temperature shall be measured and monitored by use of thermocouples with calibrated recorders.

3.4.2 The periodicity of calibration of the equipment must be every twelve months or before use.

3.4.3 Where the soaking temperature is found to be lesser than specified, the PWHT cycle shall be repeated.

3.4.4 In case interruption during PWHT, the following actions are to be taken depending on the stage during which interruption occurred.

a. Interruption during heating cycle:

- The whole operation to be repeated from the beginning

b. Interruption during soaking:

- The joint can be treated subsequently for the balance left over soaking period.

c. Interruption during cooling:

- Ensure slow cooling by covering with insulation to a minimum width of 1.5 times the outer diameter applied equally about the central line of weld, till the temperature reaches around 350 deg.C.

- 3.5 THERMOCOUPLE ( t / c) Fixing:
- 3.5.1 Thermocouples shall be used for recording post weld Heat Treatment temperatures.
- 3.5.1.1 Following are guidelines regarding number and placement of thermocouples.
- 3.5.1.2 Minimum of two thermocouples per weld.
- 3.5.1.3 Thermocouples located 180 deg. Apart.
- 3.5.1.4 Thermocouples located top and bottom of weld.
- 3.5.1.5 Thermocouples located at a distance of approximately 1.5 times of the wall thickness about the centre line of weld.
- 3.5.2 The following guidelines may be used for attaching thermocouples to job.
- a. For capacitor discharge method: Thermocouple elements should be attached within 6 mm of each other.
  - b. For other type of t / c Insert the elements in a ss tube of internal diameter approximately 6 mm. Apply force on tube and crimp it. Place this t / c and weld the crimped button to the pipe in area of interest. Do not weld the elements.
  - c. Insulate the t / c leads suitably and protect t / c ends from direct radiation from heating elements.
- 3.5.3 For Bunched Tubes:
- 3.5.3.1 Where a bunch of closely placed tube welds (e.g Super Heater / Reheater Coils) require to be stress relieved, the same shall be grouped together as if they form a single component.
- 3.5.3.2 In such cases attachment of a minimum of three thermocouples, two at the end tubes and one at the middle is recommended.
- 3.6 Soaking Time
- 3.6.1 Wherever not specified the soaking time shall be 2.5 minutes per mm. The minimum soaking shall be 30 minutes.

- 3.6.2 The following guidelines shall be used to determine the thickness and subsequent selection of the soaking time of PWHT.
- a. For butt welds, the thickness shall be the thickness of the material at the weld. For bar stock, the thickness shall be the diameter.
  - b. For fillet welds, the thickness shall be the throat thickness.
  - c. For partial penetration branch welds, the thickness shall be the depth of the groove prior to welding.
  - d. For repairs, the thickness shall be the depth of the groove as prepared for repair welding.
  - e. For combination of different welds in a component, the maximum thickness in the definitions given above shall govern.
- 3.6.3 Soaking time is to be reckoned from the time temperature of the joint crosses the recommended lower temperature of the cycle, to the time it comes down below the same recommended lower temperature of the cycle.
- 3.7 Heating and Cooling rates:
- 3.7.1 Whenever not specified, the heating rate above 400 deg. C and cooling rate after soaking upto 400 deg.C shall be as follows. This is applicable for all materials other than BS 3604:622 and 660 materials.

Thickness of Material	Maximum Heating Rate Above 400 Deg.C	Maximum Cooling Rate Upto 400 Deg.C
Upto and including 25 mm	220 Deg. C / Hour	110 Deg.C / Hour
Over 25 to 50 mm (incl)	110 Deg. C / Hour	110 Deg.C / Hour
Over 50 to 75 mm (incl.)	75 Deg. C / Hour	110 Deg.C / Hour
Over 75 mm	55 Deg. C / Hour	110 Deg.C / Hour

For Structural – 65 deg. C / Hour (Max.)

3.7.2 For BS:3604:622 and 660 materials, for a combination of diameter below 127 mm and thickness below 12.5 mm, maximum rate of heating is

$$\frac{250 \times 25}{T} \quad \text{or } 100 \text{ deg.C / Hour, whichever is less.}$$

Maximum rate of cooling is 50 deg C / hour.

T = Thickness of material in MM.

3.8 Temperature Records:

3.8.1 All the heat treatment cycles may be controlled within a tolerance of + or - 20 deg. C around the recommended temperature. The recommended temperature for stress relieving must be selected as the midpoint of recommended range of temperature for the material.

3.9 All the heat treatment cycles may be controlled within + / - 20 deg.C around the midpoint of the recommended range of temperature for the material.

4.0 SR Job Card:

4.1 Prior to start of stress relieving operations, a job card may be prepared including details of weld reference, soaking time, soaking temperature, maximum rates of heating and cooling, temperature recorder details, date of PWHT as per sample format.

4.2 On completion of PWHT the actuals may be recorded on the job card.

4.3 A chart number shall be given to each chart.

5.0 List of Tables:

Table – 1 PH, PWHT for GIRTH BUTT Welds in Tubes and Pipes Dia  $\leq$  76.1 mm.

Table – 2 PH, PWHT for Headers

Table – 3 PH, PWHT for Pipes Dia  $>$  108 mm

Table – 4 Heat Treatment requirements for Non-Pressure Parts including Structurals.

Table – 5 PH for Flame Cutting

Annexure – 1 Soaking Time

Annexure – 2 Heat Treatment of X-20 materials.

6.0 Records:

6.1 Pertinent Records like Job Card, SR Charts, shall be maintained.

## STRESS RELIEF (S.R) JOB CARD

Site: -----

Date: \_\_\_\_\_

Unit No. -----

Package: \_\_\_\_\_

Description -----

Temp. Recorder Details

Weld Reference -----

1. Make-----

Material Spec:-----

2. Type-----

Size: Dia-----mm

3. Sl.No:-----

Thick---(t) -----mm

4. Calibration  
Due on:-----

NDE Cleared on:-----

Thermocouple Locations:

Minimum 2

$d = 1.5 \times t$

Heating Band =  $6 \times t$

Insulation Band =  $12 \times t$

Date of S.R.-----

Start Time:-----

End Time-----

Chart No.:-----

Required

Actual

Rate of Heating (Max) deg C / h

-----

-----

Soak Temperature deg C

-----

-----

Soak Time (Minutes)

-----

-----

Rate of Cooling(Max) deg C / h

-----

-----

Contractor

B.H.E.L

Results

Accepted / Not Accepted:

Released for further processing

**TABLE – I**  
**GIRTH BUTT WELDS**  
**(Tubes and Pipes Dia ≤ 76.1)**

Applicable for Thickness upto 19 mm for P1ABC and Thickness  
Upto 13 mm for other materials

MATERIAL		PROCESS	P1ABC	P3A	P4Gr.1,2	P5 Gr.1	P5 Gr.2	P8
P1	GTAW SMAW	PH	NIL					
		PWHT	NIL					
P3 Group 1	- do -	PH	NIL	NIL				
		PWHT	NIL	NIL				
P4 Group 1 & 2 (Note 1)	- do -	PH	120	120	120			
		PWHT	NIL	NIL	NIL			
P5 Group 1 (Note 1)	- do -	PH	200	200	200	200		
		PWHT	NIL	NIL	NIL	NIL		
P5 Group 2	- do -	PH	200	200	200	200	200	
		PWHT	680-720	680-720	680-720	680-720	680-720	
P8 Group 1 & Group 2	- do -	PH	NIL	NIL	120	150	200	NIL
		PWHT	NIL	NIL	NIL	NIL	680-775	NIL

Note: Preheating of P4 and P5 tubes can be waived off if PWHT is envisaged at site.

If Preheating is done for the above, PWHT can be waived off subject to the approval from Chief Inspector of Boilers of the respective region.

PH = Preheat; PWHT = Post Weld Heat Treatment.

**TABLE – II****PREHEAT AND PWHT TO HEADERS**

(Note – 4)

(Applicable for Welding of Header to Header Joints at Site)

Header Pipe Material (Note 3)	Thickness, (mm)	Preheat °C	Post Heating (Note 2) °C	PWHT °C
P1 Group 1 & 2 (Note 1)	$t \leq 25$	NIL	NIL	600-650
	$t \ 25 - 75$	100	NIL	600-650
	$t > 75$	150	NIL	600-650
P4 Group 1 & Group 2	$t \leq 75$	120	NIL	650-700
	$t > 75$	150	NIL	650-700
P5 Group 1	Plates & Pipes	150	250 <sup>0</sup> for 4 hours	700-750
	Castings & forgings	200		

Note 1: For SA 106 Gr. C materials, a minimum preheat of 100<sup>0</sup>C is required for all thickness and a post heat of 150<sup>0</sup>C for two hours after completion of welding.

Note 2: All P5 headers shall be interstage heat treated at 700-750<sup>0</sup>C for 30 minutes soaking prior to any cold straightening operation. In lieu of this, the straightening can be done after final PWHT.

Note 3: Irrespective of the stub or attachment material, the PWHT cycles shall be governed by the header pipe material. However, the preheat for welding shall be as shown below:

P1 Header to P3 stub	-	120 <sup>0</sup> C (min.)
P1 Header to P4 stub	-	120 <sup>0</sup> C (min.)
P1 Header to P5 stub	-	150 <sup>0</sup> C (min.)

Note 4: Seal welding of hand hole plates, radiographic plugs and screws can be carried out after final PWHT, provided the preheat is carried out as per the table.

Note 5: Soaking time for BS 622 & 660 materials shall be 180 mts. (min) irrespective of thickness. However, when diameter is less than 127 mm and thickness less than 12.5 mm, soaking time shall be 30 minutes (min).

Note 6: Throat shall be as specified in the drawing. Wherever flanges are welded to pipes combined throat shall be taken into consideration.

**TABLE - IV**

**Heat Treatment Requirements for Non Pressure Parts Including Structurals (Note 7)**

Material	Shearing	Gas cutting	Thickness	Welding		
	Post Forming Heat Treatment	Preheat		SMAW (Non-Low H <sub>2</sub> Electrodes)	SMAW (Low H <sub>2</sub> electrodes) GMAW, SAW etc.	PWHT (Note 7)
P1 A.36 Is 2062 IS 226	t ≤ 19 – Nil t > 19 – 600-650 <sup>0</sup> C No<- soaking <- is required. (Note 1)	t ≤ 50 – Nil t > 50, 100 <sup>0</sup> C	t ≤ 19 t - 19 – 38 t - 38 – 63 t > 63	Nil 100 120 150	Nil Nil 100 120	a. All butt welds when > 50 mm b. Any welds to a tension member (Note 2) SR at 600-650 <sup>0</sup> C
P4	All sheared edges at 650 – 700 <sup>0</sup> C for 15 mts.	t ≤ 25 – Nil t > 25, 120 <sup>0</sup> C	t < 75 t > 75	--- ---	120 150	a. All butt welds in tension member. b. All fabricated components when t>16 mm (Note 3) SR at 650 – 700 <sup>0</sup> C
P5	All sheared edges at 680-730 <sup>0</sup> C for 15 mts.	t ≤ 13, 120 <sup>0</sup> C t 13 – 25, 150 <sup>0</sup> C t > 25, 200 <sup>0</sup> C (Note 4)	All	---	150	All welds (Note 5 & 6) SR at 680-730 <sup>0</sup> C

- Note 1: Clip angles above 10 mm, used for beam connections, which are sheared to length, shall required heat treatment.
- Note 2 : All tension members, when thickness is above 50 mm, the entire assembly shall be post weld heat treated.
- Note 3 : All fabricated structural components of P-4 material, with any member above 16 mm thickness, the entire assembly shall be post weld heat treated.
- Note 4: All gas cut edges of P-5 material shall be heat treated at 680-730<sup>0</sup>C for 15 mts. As an alternative to this heat treatment, the gas cut edges may be chipped off, ground or machined to remove the HAZ with 6 mm minimum removal.
- Note 5 : All welds of P-5 material shall be post heated at 250<sup>0</sup>C for 2 hours or 150<sup>0</sup> C for 4 hours immediately following welding.
- Note 6 : All fabricated structural members of P-5 material, the entire assembly shall be post weld heat treated after completion of fabrication.
- Note 7: For soaking time details refer Annexure – I.