



429-002/A

**BHARAT HEAVY ELECTRICALS LIMITED**

( A Government of India Undertaking )  
HIGH PRESSURE BOILER PLANT  
PURCHASE DEPARTMENT - FOSSIL BOILERS  
THIRUCHIRAPALLI - 620014  
TAMILNADU (INDIA)

Page  
1/1  
PHONE :2577629  
GRAMS : BHARATELEC  
FAX NO: 2520719  
E-mail: srchandran@bheltry.co.in  
Web:

Enquiry No	Enquiry Date	Due Date for Quotation
2661400615 - 55	05.09.2014	30.09.2014
Please quote Enquiry No, Date and due date in all correspondences. This is only a request for quotation and not an order		

Item	Description	Unit	Quantity	Delivery Quantity	Schedule Date
10	<b>7520C6003400</b> GEAR BOX ASSY. (WET GRINDER) AS PER DRAWING: 2M 20C 60 05025 ALL PARTS ARE IN ASSEMBLED CONDITION. (SUB DRGS. NO. 3M 20C 60 15076, 3M 20C 60 15089, 4M 20C 60 29655, 3M 20C 60 12733-01, 4M 20C 60 27860-02, 3M 20C 60 15090, 4M 20C 60 29659, 4M 20C 60 29660, 3M 20C 60 15091, 4M 20C 60 29661, 4M 20C 60 29663-01). VENDOR QUALIFYING CRITERIA Only those vendors who satisfy the following conditions will get qualified to participate in the tender: 1.,Vendor should have minimum 3 years of experience in this field. 2.,Previous PO details for supplying similar kind of items to BHEL and/or any-other Organisation should be submitted along with offer. Otherwise offer will be rejected. 3.,Company profile details has to be provided along with offer. 4.,BHEL reserves the right to visit the vendor's works for verifying the manufacturing facilities and any other credential furnished by the vendor. In case the information furnished with the offers found to be false /incorrect, the offer shall be rejected.	NO	4.000	4.00	15.11.14

**General Note:**

**Enclosures:**

"LD clause has to be confirmed without fail."

The offers should reach us 30 minutes before the time of opening of tenders. The offers will be opened at 14.30 hrs on the due date of tender in the presence of tenderers who have submitted their offer and who may like to be present for the tender opening. Late and delayed offers are liable to be rejected.

Yours faithfully,  
For **BHARAT HEAVY ELECTRICALS LIMITED**

*Fey*  
  
MANAGER / PURCHASE  
(FOSSIL BOILERS)  
Yours faithfully,

**CAPITAL PURCHASE**  
**COMMERCIAL TERMS AND CONDITIONS**

**1.0 QUOTATIONS**

The Bidders shall submit the offer in **TWO INNER ENVELOPES** as indicated below which shall be sealed in one outer envelope.

**Envelope I** This sealed envelope should contain all the copies of technical bid together with un-priced commercial bid & annexure III. This envelope should be clearly marked **'Part I - Technical and commercial bid'**,

Indicating Enquiry No., Due Date and Address & Reference of the Bidder.

**Envelope II** This sealed envelope should contain **price as per Annexure-IV format**. This envelope should be clearly marked **"Part II - Price bid"**, indicating **Enquiry No., Due Date and Address & Reference of the Bidder**.

Both the envelopes (Part I & II) shall be put in one cover (**Envelope III**), duly sealed, superscribing as Part I and Part II of Enquiry No., due date of opening and the address and reference of the Bidder

The above offer should reach this office on or before the due date by 14.00 hours (IST). Late offers will not be considered.

Tender should not be addressed to any individual's name but only by designation to

**SENIOR MANAGER /PURCHASE/ CP & SP/ MM / MFG  
BHARAT HEAVY ELECTRICALS LIMITED  
HIGH PRESSURE BOILER PLANT  
TIRUCHIRAPALLI - 620 014  
TAMIL NADU**

Tenders should be free from **CORRECTION AND ERASURES**, Corrections if any, must be attested. All Amounts shall be indicated both in words as well as in figures. Where there is difference between amount quoted in words and figures, amount quoted in words shall prevail.

Offers should be in **ENGLISH** and accompanied by detailed technical literature, catalogue and detailed dimensional drawings in **ENGLISH** or otherwise, the offers will not be considered.

**2.0 OPENING OF TENDERS**

The Part I - Technical & commercial bid alone would be opened on the Tender opening date.

The Part II - Price bid of technically suitable Bidders alone would be opened. The Technically Suitable Bidders would be informed about the tender opening date through e-mail.

Clarifications if any required by BHEL for Technical evaluation **would be** sought from Bidders before opening of Part II - price bid

**For any queries clarifications the bidders may contact us through our FAX NO. +91 431 2520719 or through e-mail < mmcpmfg1@bheltry.co.in > & < chells@bheltry.co.in>**

MM: CP &amp; SP

**Annexure For Techno Commercial Bid**  
Check List - to be filled and submitted along with Technical Bid

BHEL Commercial Terms and Conditions for Indigenous Supplies	Vendor's Confirmation / Comments
Technical confirmation to BHEL's Specification as called for in BHEL Format shall be furnished. If needed additional sheets shall be used.	
Prices shall be <b>quoted item wise</b> only as per the model format enclosed	
Prices shall be quoted on " <b>FIRM PRICE</b> " basis only The prices should be only on <b>F.O.R / Despatching station basis with Packing &amp; Forwarding charges if any. Applicable % of ED &amp; Sales Tax, Freight &amp; Insurance, Installation &amp; Commissioning Charges should be clearly Indicated</b>	
<b>Validity of offer</b> shall be for a minimum period of 120 days from the date of Tender opening	
Delivery period from the date of Letter of Intent / Purchase order shall be clearly mentioned in the offer	
<b>Liquidated damages @ '0.5% per week</b> subject to a maximum of 10% of the order value shall be applicable for delay in deliveries <b>For Details Refer Annexure- v</b>	
<b>Following Risk Purchase clause</b> shall be applicable The purchaser at his option will be entitled to terminate the contract and to purchase elsewhere at the risk and cost of the seller either the whole of the goods or any part which the supplier has failed to deliver or dispatch within the time stipulated or if the same were not available, the best and the nearest available substitute therefore The supplier shall be liable for any loss which the Purchaser may sustain by reason of such risk purchases	
<b>Payment term for supply portion:</b> Payment term is 100% direct payment after 45 days from the date of receipt and acceptance of materials <b>For details Refer Annexure- v</b>	
Erection / commissioning: (if applicable only) Erection / commissioning charges if any has been mentioned in the offer or else confirmation that Erection / commissioning shall be done at free of cost is available in the offer,	
The equipment shall be guaranteed for a period of 12 months from the date of commissioning	
Final inspection and acceptance of equipment will be after installation at BHEL, Trichy	
The vendor shall provide necessary drawings, Test Certificates and Operating Maintenance Manuals etc., as called for in the Technical Specification, in the required number of copies at no extra cost	
Any warranty replacement during warranty period shall be supplied free of charge on FOR BHEL, Trichy basis.	
Offers should be submitted only in <b>sealed cover super-scribing clearly the Enquiry reference and due date.</b>	
% of Excise Duty with cess	
% of TAX (CST/VAT):(INGST with FORM-17 or CST with C-FORM)	
Packing & Forwarding Charges ( if any in % only)	
Percentage of Freight& transit insurance charges, if any Freight charges from Dispatching station to BHEL, Tiruchirappalli • Supplier should quote for F.O.R-BHEL Trichy Stores.	
As per Commercial terms and conditions, acceptance for participation in Reverse auction (RA).Yes/No to be indicated	
Name of the person for participating reverse auction	
Land Line Number	
Fax Number	
Mobile Number	
E-mail ID	

## NOTE:-

- It is confirmed that all the terms and conditions stipulated in the Enquiry have been fully understood by us and all clarifications & details have been obtained.
- Your offer should be indicating applicable if any P&F Charges, % of ED, Sales Tax -CST or VAT, Service Tax), Freight, Insurance and Installation and Commissioning Charges etc., as per our Price Format
- Your specific acceptance to our Payment terms, LD & Risk Purchase Clause are essential for consideration of your offer. Other wise your offer is liable for rejection.
- No row shall be left blank. Please indicate NA, in case the item is "not applicable"



<b>Payment Term (Indigenous)</b>	
<b>If materials are receivable at Stores/Trichy without PBG</b>	Payment term is 100% direct payment after 45 days from the date of receipt and acceptance of materials.
<b>If materials are receivable at Stores/Trichy with PBG</b>	Payment term is 100% direct payment after 45 days from the date of receipt and acceptance of materials and against 10% PBG valid for the warranty period.
Any deviation in the above payment term will attract loading as mentioned below. “Base rate of SBI (as applicable on the date of bid opening. Techno-commercial bid opening in case of two part bids) + 6% shall be considered for loading for the period of relaxation sought by bidders.	

Payment through Bank is not preferred. In case of Payment through Bank is opted by Supplier, BHEL prefers documents submission through bank with copy of LR and door delivery of Goods to Site/Stores with Consignee copy attached. In this case Loading will be 3% on the offered value.

Offers of indigenous Suppliers with payment terms as LC/Advance Payment are liable for rejection.

#### **Liquidated Damages / Penalty -**

Liquidated damages shall be 0.5% of the total order value per week or part thereof subject to a maximum of 10% of the total order value.

For staggered delivery schedule, LD shall be 0.5% of the undelivered portion per week of the delay or part thereof subject to a maximum of 10% of the total order value.

Any deviation from the above LD clause, loading will be applied to the extent to which it is not agreed by the bidder (at offered value).

#### **Guarantee / Warranty Period – (if applicable)**

Normally No deviation permitted and the deviated offers are liable for rejection.

#### **Ranking-**

BHEL will consider the ranking after the loading is applied as referred above wherever deviations are observed.

#### **Performance Bank Guarantee – (if applicable)**

Normally No deviation permitted and the deviated offers are liable for rejection.

#### **NOTE:-**

1. If the due date of tender opening happens to be a holiday, the tenders will be opened on the next working day.
2. BHEL reserves the right to go for a reverse auction (RA) instead of opening the submitted sealed bid which will be decided after technical evaluation. Information and general terms and conditions covering RA are given in commercial terms and conditions.
3. Corrigendum if any, with respect to this tender will be hosted only in the website <http://www.bhel.com> or <http://tenders.gov.in>. You are requested to visit the website regularly for updates.

**Special Provisions for Micro and Small Enterprises (MSE)**

1. 20% of the tendered quantity is earmarked for MSE suppliers in this tender.
2. Out of the 20% tendered quantity reserved for MSE suppliers, 4% shall be earmarked for procurement from MSE owned by SC/ST entrepreneurs.
3. In case MSE vendor participating in the tender quotes within the price band of L1+15%, they will be allowed to supply the portion of the requirement subject to acceptance of L1 price by MSE vendor. In case of more than one such MSE, the supply shall be shared proportionately.
4. "MSE suppliers can avail the intended benefits only if they submit along with the offer, attested copies of either EM II certificate having deemed validity (five years from the date of issue of acknowledgement in EM-II) or valid NSIC certificate or EM II certificate along with attested copy of a CA certificate (Format enclosed at Annexure -VII where deemed validity of EM II certificate of five Years has expired) applicable for the relevant financial year (latest audited). Date to be reckoned for determining the deemed validity will be the date of bid opening (Part 1 in case of two part bid). Non submission of such documents will lead to consideration of their bid at par with other bidders. No benefit shall be applicable for this enquiry if any deficiency in the above required documents are not submitted before price bid opening. If the tender is to be submitted through e-procurement portal, then the above required documents are to be uploaded on the portal. Documents should be notarized or attested by a Gazetted officer."

**Certificate by Chartered Accountant on letter head**

This is to Certify that M/S .....  
(hereinafter referred to as 'company') having its registered office at  
..... is registered under MSMED Act 2006, (Entrepreneur  
Memorandum No (Part-II) ..... dtd:.....,  
Category: ..... (Micro/Small)). (Copy enclosed).

Further verified from the Books of Accounts that the investment of the company as on  
date..... as per MSMED Act 2006 is as follows:

1. **For Manufacturing Enterprises:** Investment In plant and machinery (i.e. original cost  
excluding land and building and the items specified by the Ministry of Small Scale Industries vide its  
notification No.S.O.1722(E) dated October 5, 2006 :  
Rs.....Lacs
2. **For Service Enterprises:** Investment in equipment (original cost excluding land and building and  
furniture, fittings and other items not directly related to the service rendered or as may be notified under the MSMED  
Act, 2006:  
Rs.....Lacs

The above investment of Rs.....Lacs is within permissible limit of  
Rs.....Lacs for .....Micro / Small (~~Strike off which is not applicable~~)  
Category under MSMED Act 2006.

Date:

(Signature)

Name -

Membership number -

Seal of Chartered Accountant

CAUTION: THIS DRAWING IS OUR SOLE PROPERTY AND SHOULD NOT BE USED IN ANY FORM FOR ANY PURPOSE WITHOUT THE WRITTEN PERMISSION OF BHARAT HEAVY ELECTRICALS LIMITED

ALL DIMENSIONS ARE IN MM

Ø22H7

+0.021  
+0.000

6P9

-0.012  
-0.042

3.2//1.6//0.8//

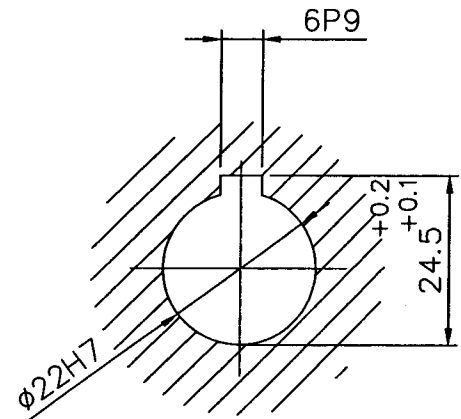
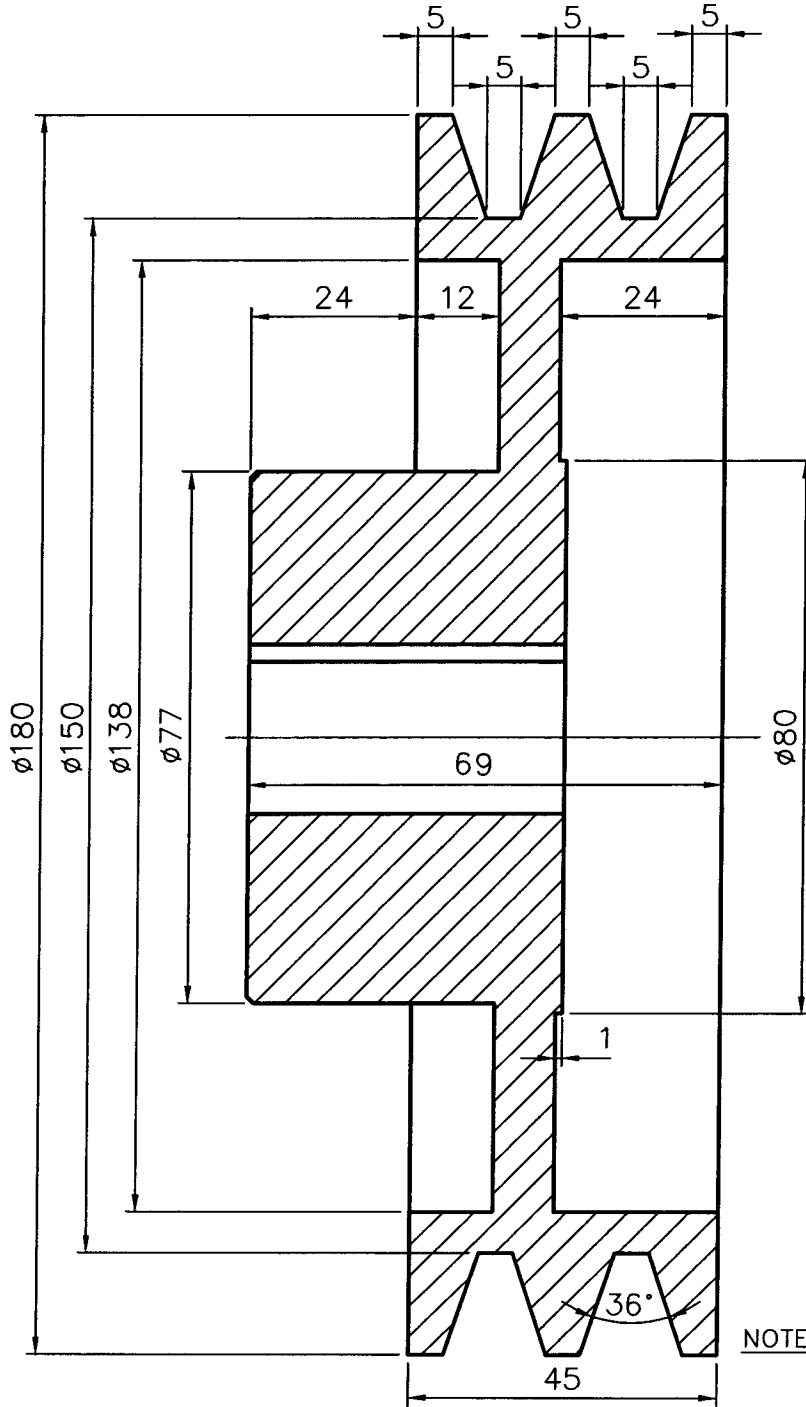

NOTE: -  
CHAMFER CORNERS FOR 1/45°



No. of Pieces		DESCRIPTION	MATERIAL	STANDARD	NET.WT.IN KGS.	DRAWING No.	ITEM No.
		REFERENCE:		ALTERATIONS:	DCN REF	DATE	SIGN.
SCALE	DRN.	T.T.BALAKRISHNAN					
	CHD.	R.RAMAMOORTHY					
	APPD.	K.RAMANAN					
	DATE	20.03.13					
MACHINE: CANTEEN EQUIPMENT				TYPE: CANTEEN			
TITLE:				DRAWING No:			
PULLEY OD180x69t				4M20C6029661			
(WET GRINDER)				Sheet No:			
				No. of Sheets:			

CAUTION: THIS DRAWING IS OUR SOLE PROPERTY AND SHOULD NOT BE USED IN ANY FORM FOR ANY PURPOSE WITHOUT THE WRITTEN PERMISSION OF BHARAT HEAVY ELECTRICALS LIMITED

ALL DIMENSIONS ARE IN MM

10P9	-0.015	3.2//1.6/
	-0.051	

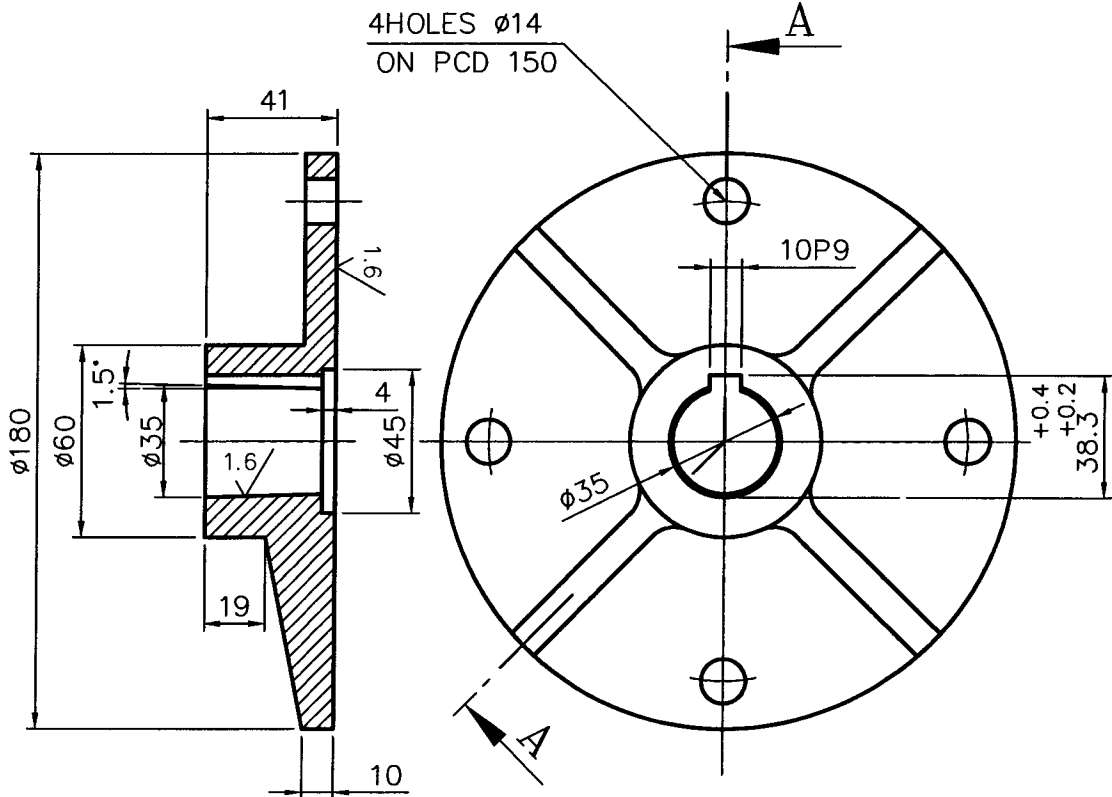

SECTION-AA



NOTE: -  
CHAMFER CORNERS FOR 1/45'  
HARDENED TO HRC.35 ±2

X		55C8	IS: 5517	0.45	2M20C6005025	07
No. of Pieces	DESCRIPTION	MATERIAL	STANDARD	NET.WT.IN KGS.	DRAWING No.	ITEM No.
	REFERENCE:	ALTERATIONS:		DCN REF	DATE	SIGN.
		MATERIAL WAS CHANGED			02.06.14	R.R.M
SCALE 1:2	DRN.	T.T.BALAKRISHNAN				(01)
	CHD.	R.RAMAMOORTHY				
	APPD.	K.RAMANAN				
	DATE	04.04.13				
MACHINE: CANTEEN EQUIPMENT			TYPE: CANTEEN			
TITLE: <b>FLANGE COUPLING</b> (WET GRINDER) OD180x41T			DRAWING No: <b>4M20C602966301</b>			
			Sheet No:			No. of Sheets:

THIS DRAWING IS OUR SOLE PROPERTY AND SHOULD NOT BE USED IN ANY FORM FOR ANY PURPOSE WITHOUT THE WRITTEN PERMISSION OF BHARAT HEAVY ELECTRICALS LIMITED

CAUTION:

ALL DIMENSIONS ARE IN MM

3.2//1.6/  
✓/✓/✓

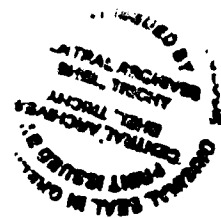
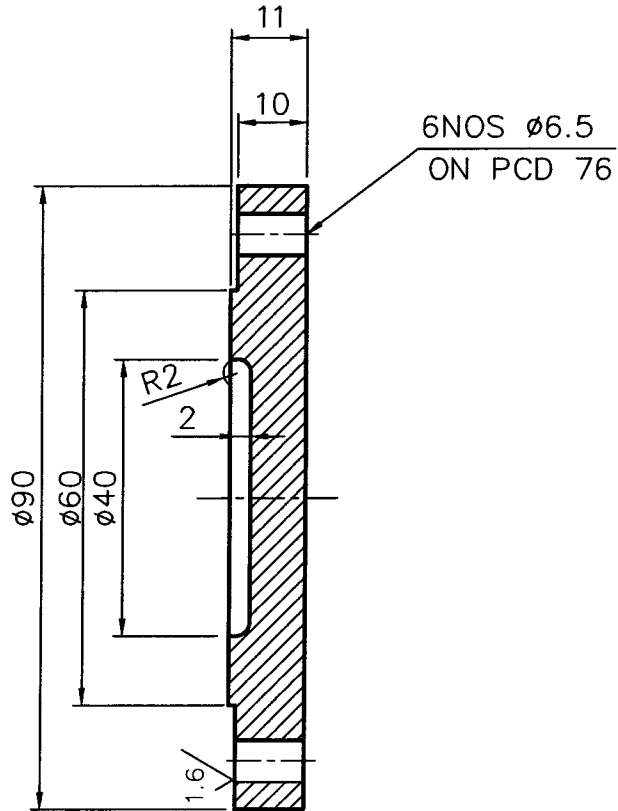

NOTE: -  
CHAMFER CORNERS FOR 1/45°

No. of Pieces		DESCRIPTION		MATERIAL	STANDARD	NET.WT.IN KGS.	DRAWING No.	ITEM No.
1		Ø90x11t		45C8	IS: 2004	0.50	2M20C6005025	07
SCALE		DRN.	T.T.BALAKRISHNAN	ALTERATIONS:		DCN REF	DATE	SIGN.
1:1		CHD.	R.RAMAMOORTHY					
		APPD.	K.RAMANAN					
		DATE	20.03.13					
MACHINE: CANTEEN EQUIPMENT				TYPE: CANTEEN				
TITLE:				DRAWING No:				
END COVER Ø90x11t				4M20C6029659				
(WET GRINDER)				Sheet No:		No. of Sheets:		

THIS DRAWING IS OUR SOLE PROPERTY AND SHOULD NOT BE USED IN ANY FORM FOR ANY PURPOSE WITHOUT THE WRITTEN PERMISSION OF BHARAT HEAVY ELECTRICALS LIMITED

CAUTION:

ALL DIMENSIONS ARE IN MM

3.2//1.6/

6NOS  $\phi 6.5$   
 ON PCD 76

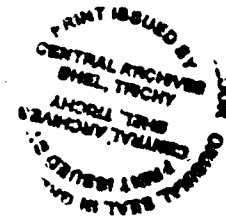
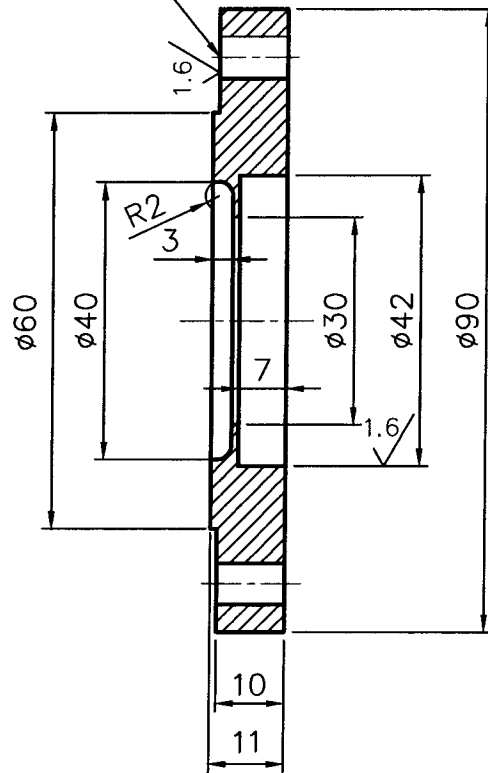

NOTE: -  
 CHAMFER CORNERS FOR  $1/45^\circ$

	$\phi 90 \times 11t$	45C8	IS: 2004	0.426	2M20C6005025	08
No. of Pieces	DESCRIPTION	MATERIAL	STANDARD	NET.WT.IN KGS.	DRAWING No.	ITEM No.
		REFERENCE:	ALTERATIONS:	DCN REF	DATE	SIGN.
SCALE	DRN.	T.T.BALAKRISHNAN				
1:1	CHD.	R.RAMAMOORTHY				
	APPD.	K.RAMANAN				
	DATE	20.03.13				
	MACHINE: CANTEN EQUIPMENT		TYPE: CANTEN			
	TITLE: END COVER $\phi 90 \times 11t$ (WET GRINDER)		DRAWING No:			
			4M20C6029660			
			Sheet No:			No. of Sheets:

ALL DIMENSIONS ARE IN MM

ø90H7	-0.012	1.6/0.8/
	-0.042	

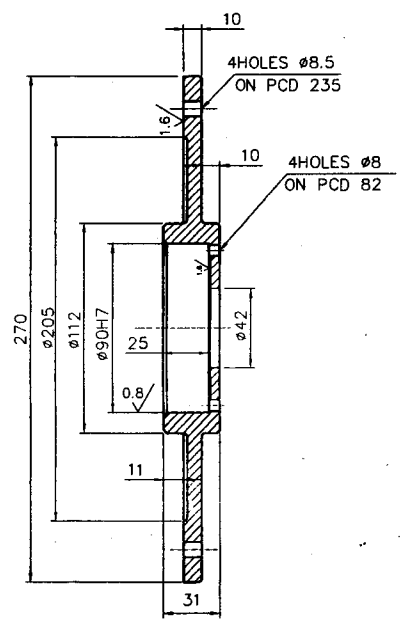
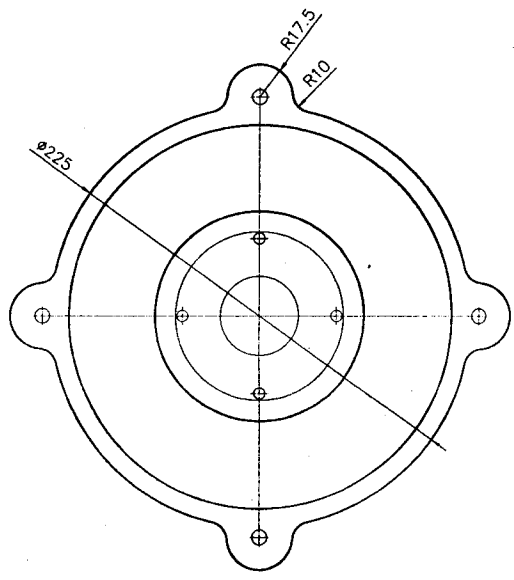

NOTE: -

- 01. MATL. SHOULD BE FREE FROM CRACKS, BLOWHOLES AND POROSITY.
- 02. SHARP CORNERS TO BE REMOVED

X		FG 220	IS: 210	4.53	2M20C6005025	09
No. of Pieces	DESCRIPTION	MATERIAL	STANDARD	NET.WT. IN KGS.	DRAWING No.	ITEM No.
	REFERENCE:		ALTERATIONS:	DCN REF	DATE	SIGN.
SCALE	DRN.	T. BALAKRISHNAN				
1:2	CHKD.	K. RAMAMURTHY				
	APPD.	K. RAMAMURTHY				
	DATE	20.03.13				
MACHINE: CANTEEN EQUIPMENT				TYPE: CANTEEN		
TITLE:				DRAWING No:		
GEARBOX HOUSING COVER				3M20C60115091		
(WET GRINDER)				Sheet No:		
				No. of Sheets:		

CAUTION: THIS DRAWING IS OUR SOLE PROPERTY AND SHOULD NOT BE USED IN ANY FORM FOR ANY PURPOSE WITHOUT THE WRITTEN PERMISSION OF BHARAT HEAVY ELECTRICALS LIMITED

ALL DIMENSIONS ARE IN MM

$\phi 60.03 h11$	-0.000	8 P9	-0.015
	-0.190		-0.051
$\phi 28H7$	+0.021		
	+0.000		

3.2 // 1.6 // 0.8 //

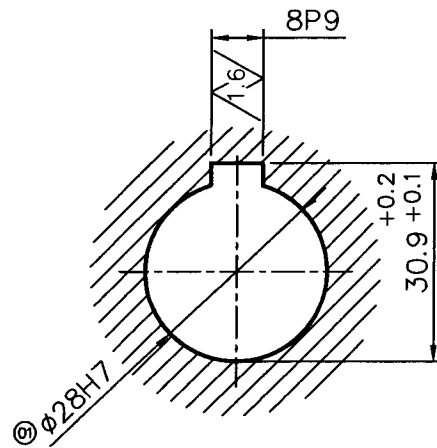
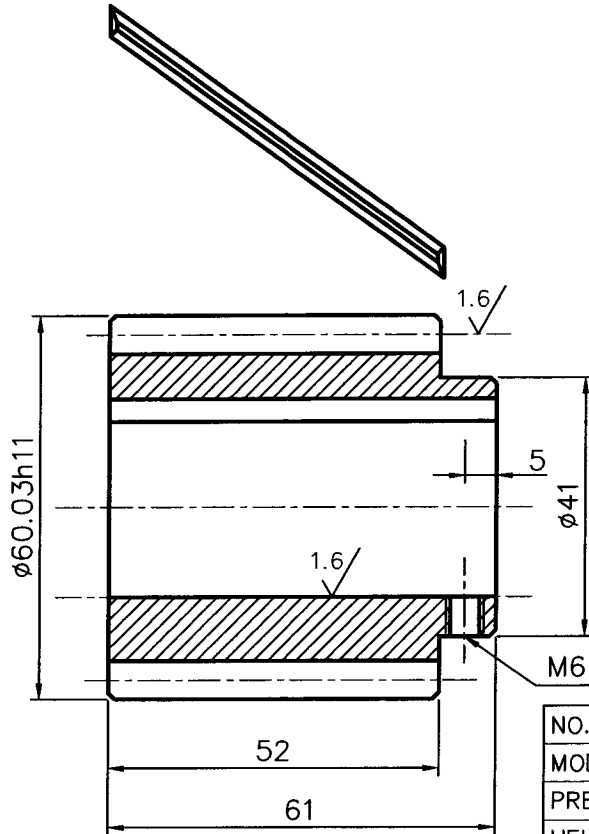
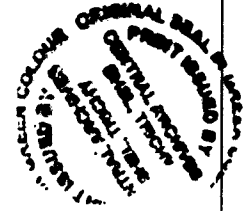

NO.OF TEETH	15
MODULE	2.5
PRESSURE ANGLE	20°
HELIX ANGLE	45°
HAND OF HELIX	RH
WITH ACROSS 5 TEETH	35.27 <sup>-0.141</sup> <sub>-0.188</sub>
CORRECTION FACTOR	+0.4
QTY.&TOL.ZONE	9c DIN 3967
MATING GEAR NO.OF TEETH	56
MATING GEAR DRAWING NO:	3M20C6012733
CENTRE DISTANCE	127

NOTE: -

CHAMFER CORNERS FOR 1/45°  
HARDENED TO HRc 35 <sup>±2</sup>

No. of Pieces	DESCRIPTION		MATERIAL	STANDARD	NET.WT.IN KGS.	DRAWING No.	ITEM No.	
	REFERENCE:		ALTERATIONS:	DCN REF	DATE	SIGN.	INDEX	
SCALE	DRN.	P.A.ROSS	MATERIAL WAS CHANGED					
	CHD.	R.RAMAMOORTHY						
	APPD.	K.RAMANAN						
	DATE	06.06.2006						
1:1	MACHINE: CANTEEN EQUIPMENT			TYPE: CANTEEN				
TITLE:				DRAWING No:				
HELICAL PINION $\phi 60.30 \times 15T$				4M20C602786002				
(WET GRINDER)				Sheet No:				No. of Sheets:

CAUTION: THIS DRAWING IS OUR SOLE PROPERTY AND SHOULD NOT BE USED IN ANY FORM FOR ANY PURPOSE WITHOUT THE WRITTEN PERMISSION OF BHARAT HEAVY ELECTRICALS LIMITED

ALL DIMENSIONS ARE IN MM

3.2//1.6/

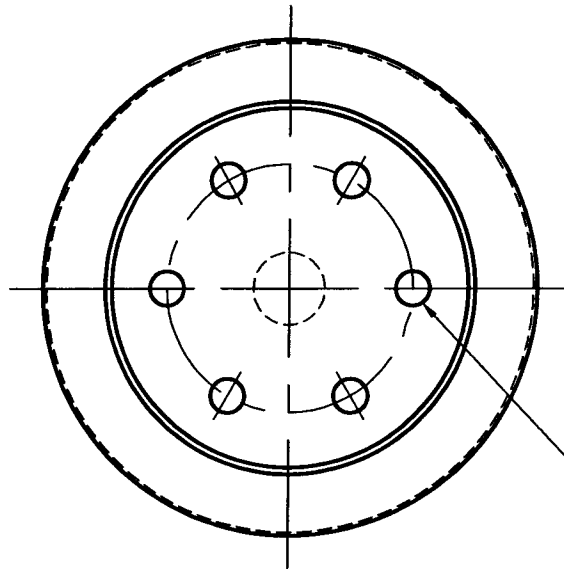
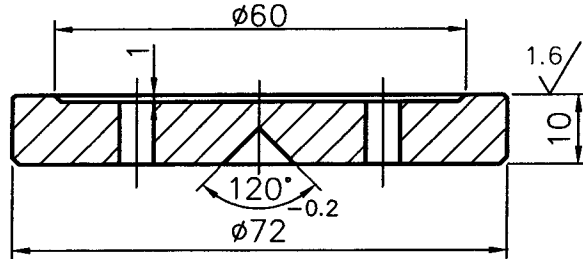

HOLE  $\phi 6$ -6NOS.  
ON PCD36

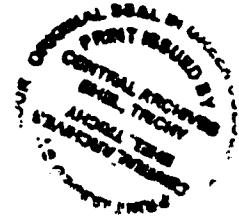

NOTE: -  
CHAMFER CORNERS FOR 1/45°

No. of Pieces		DESCRIPTION		MATERIAL	STANDARD	NET.WT.IN KGS.	DRAWING No.	ITEM No.	
1		$\phi 72 \times 10$ L		45C8	IS: 2004	0.31	2M20C6005025	03	
SCALE		DRN.	T.T.BALAKRISHNAN	CHD.	R.RAMAMOORTHY	APPD.	K.RAMANAN	DATE	20.03.13
1:1		MACHINE: CANTEEN EQUIPMENT		TYPE: CANTEEN		DRAWING No:			
TITLE:		SPACER $\phi 72 \times 10$ T		(WET GRINDER)		4M20C6029655			
Sheet No:						No. of Sheets:			





$\phi 90H7$   
 $-0.012$   
 $-0.042$

1.6 / 0.8

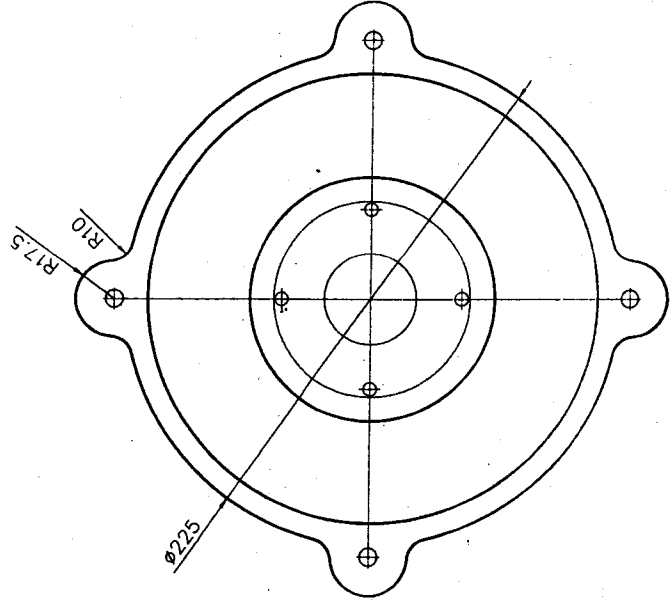
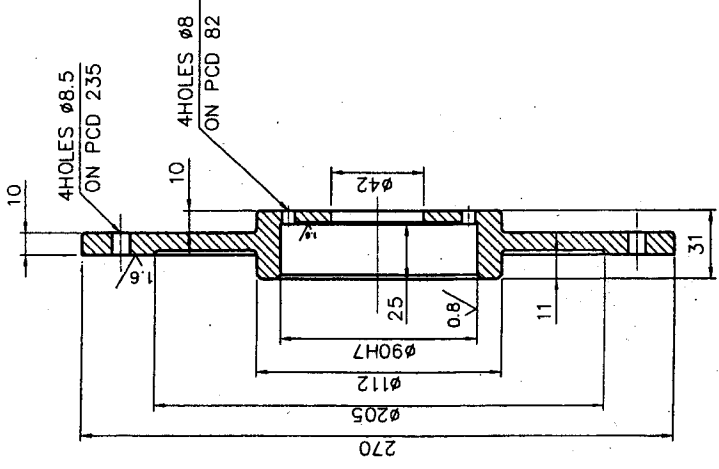

ALL DIMENSIONS ARE IN MM

THIS DRAWING IS OUR SOLE PROPERTY AND SHOULD NOT BE USED IN ANY FORM FOR ANY PURPOSE WITHOUT THE WRITTEN PERMISSION OF BHARAT HEAVY ELECTRICALS LIMITED

NOTE: -

- 01. MATL. SHOULD BE FREE FROM CRACKS, BLOWHOLES AND POROSITY.
- 02. SHARP CORNERS TO BE REMOVED

FG 220	IS: 210	4.53	2M20C6005025	09
DESCRIPTION	MATERIAL	STANDARD	NET WT. IN KGS.	DRAWING No.
REFERENCE:	ALTERATIONS:	DCN REF	DATE	SIGN.
SCALE	DRN.	T.T. BALAKRISHNAN	DATE	INDEX
1:2	CHKD.	R. RAMAMOORTHY		
	APPD	K. RAMANAN		
	DATE	20.03.13		
MACHINE: CANTREEN EQUIPMENT		TYPE: CANTREEN		
TITLE:		DRAWING No.		
GEARBOX HOUSING COVER (WET GRINDER)		3M20C6015091		
Sheet No.		No. of Sheets:		

THIS DRAWING IS OUR SOLE PROPERTY AND SHOULD NOT BE USED IN ANY FORM FOR ANY PURPOSE WITHOUT THE WRITTEN PERMISSION OF SHARAT HEAVY ELECTRICALS LIMITED

ALL DIMENSIONS ARE IN MM

25x6	+0.015 +0.002	22h6	+0.015 +0.000	28h6	+0.015 +0.000	8P9	-0.015 -0.051	6P9	-0.012 -0.042	1.6/0.8/
------	------------------	------	------------------	------	------------------	-----	------------------	-----	------------------	----------

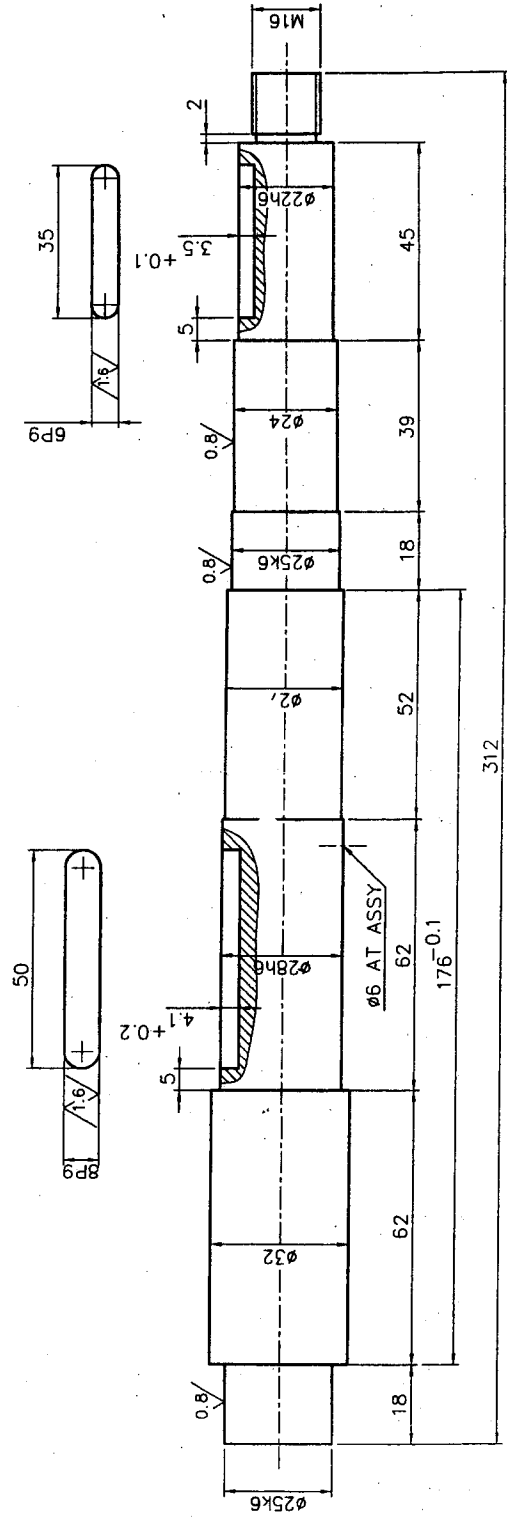

NOTE: -  
AVOID SHARP CORNER

DESCRIPTION	Ø32x312 L	45C8	IS: 2004	1.74	2M20C6005025	06
REFERENCE:						
SCALE	DRN: I.T.BALAKRISHNAN	T.T. RAJESH				
1:1	APPD: K.RAMANAN					
	DATE: 20.03.13					
MACHINE: CANTEEN EQUIPMENT		TYPE: CANTEEN				
TITLE: DRIVE SHAFT (WET GRINDER)				DRAWING No: 3M20C6015090		
				Sheet No:		No. of Sheets:

ALL DIMENSIONS ARE IN MM

12P9	-0.018 -0.061	42H7	+0.025 +0.002	ø202.98h11	-0.000 -0.290	3.2/1.6/√
------	------------------	------	------------------	------------	------------------	-----------

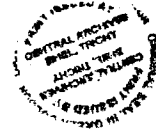
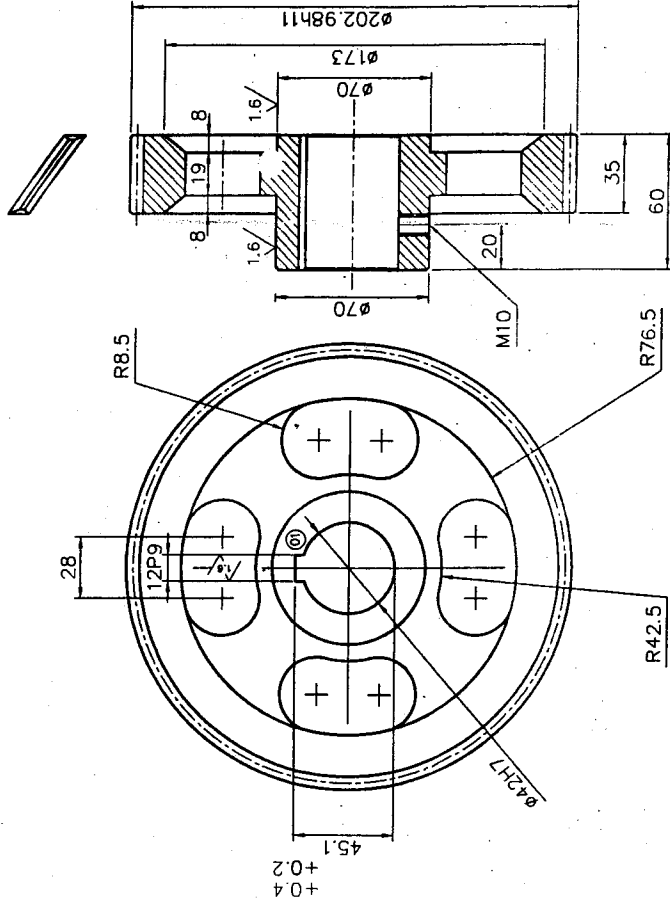

NO. OF TEETH	56
MODULE	2.5
PRESSURE ANGLE	20°
HELIX ANGLE	45°
HAND OF HELIX	RH
WITH ACROSS 5 TEETH	119.57
CORRECTION FACTOR	NIL
QUALITY & TOL. ZONE	9c. DIN 3967
MATING GEAR NO. OF TEETH	15
MATING GEAR DRAWING NO.	4M20C6027860
CENTRE DISTANCE	127

DESCRIPTION	FG 220	IS: 210	5.6	2M20C6005025	04
MATERIAL		STANDARD	NET WT. IN KGS.	DRAWING NO.	REV. NO.
ALTERATIONS:		KEY WAY ADDED	DATE	DATE	SIGN.
SCALE	DRN. P. ALBERT ROSS	DATE	27.03.87	17.04.13	KRAMANIAN
CHD. R. RAMAMOORTHY					
APPD. C.S. JAYASHELAN					
MACHINE: CANTEEN EQUIPMENT					
TITLE:	HELICAL GEAR WHEEL				
	56 T/ø202.98 (WET GRINDER)				
DRAWING No:	3M20C6011273301				
Sheet No:					
No. of Sheets:					

NOTE: - CHAMFER CORNERS FOR 2/45

THIS DRAWING IS OUR SOLE PROPERTY AND SHOULD NOT BE USED IN ANY FORM FOR ANY PURPOSE WITHOUT THE WRITTEN PERMISSION OF BHARAT HEAVY ELECTRICALS LIMITED

ALL DIMENSIONS ARE IN MM

THIS DRAWING IS OUR SOLE PROPERTY AND SHOULD NOT BE USED IN ANY FORM FOR ANY PURPOSE WITHOUT THE WRITTEN PERMISSION OF SHANT HEAVY ELECTRICALS LIMITED

30k6 40k6	+0.018 +0.002	42h6	-0.000 -0.016	12P9	-0.018 -0.061	10P9	-0.015 -0.051
--------------	------------------	------	------------------	------	------------------	------	------------------

1.6/0.8

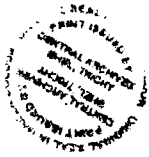
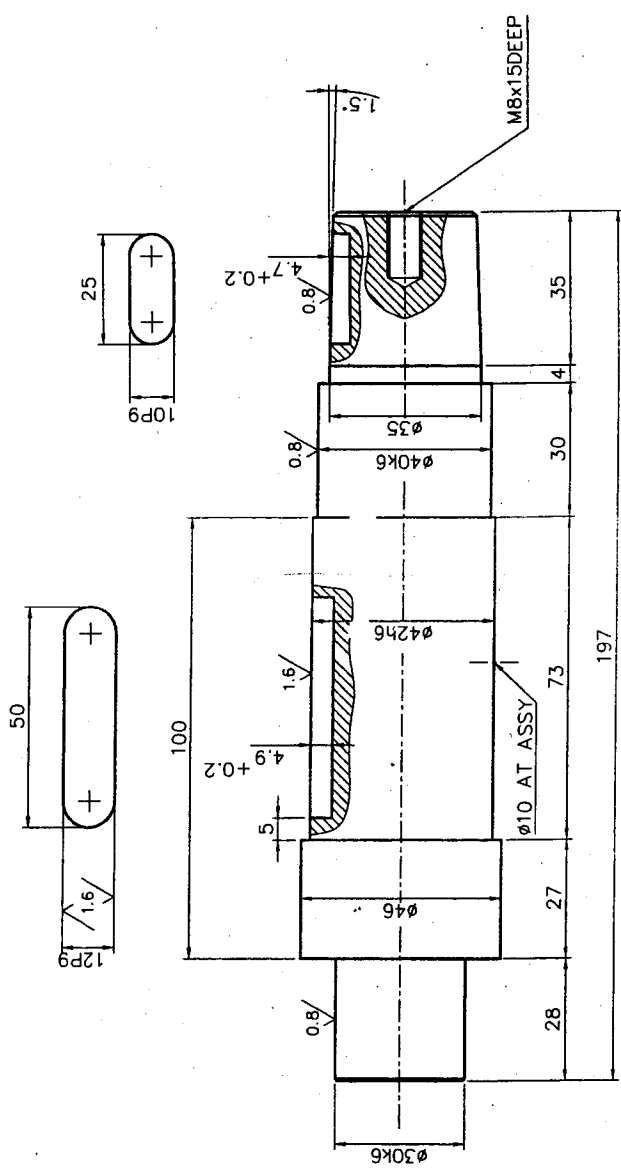

NOTE: -  
CHAMFER CORNERS FOR 1/45

	DESCRIPTION	45C8	IS: 2004	2.14	2M20C6005025	02		
	REFERENCE:	MATERIAL	STANDARD	NET WT. IN KGS.	DRAWING No.	REV. No.		
SCALE	DRN.	ALTERATIONS:		DCN	REF	DATE	SIGN.	INDEX
1:1	T. BALAKRISHNAN							
	CHD. R. RAMAMOORTHY							
	APPD. K. RAMANAN							
	DATE 20.03.13							
MACHINE: CANTEEN EQUIPMENT		TYPE: CANTEEN						
TITLE: MAIN SHAFT Ø46x197 L (WET GRINDER)		DRAWING No:		3M20C60150189		Sheet No:		No. of Sheets