

DRG. NO. 2-61-104-02339  
SHT. 01 OF 01

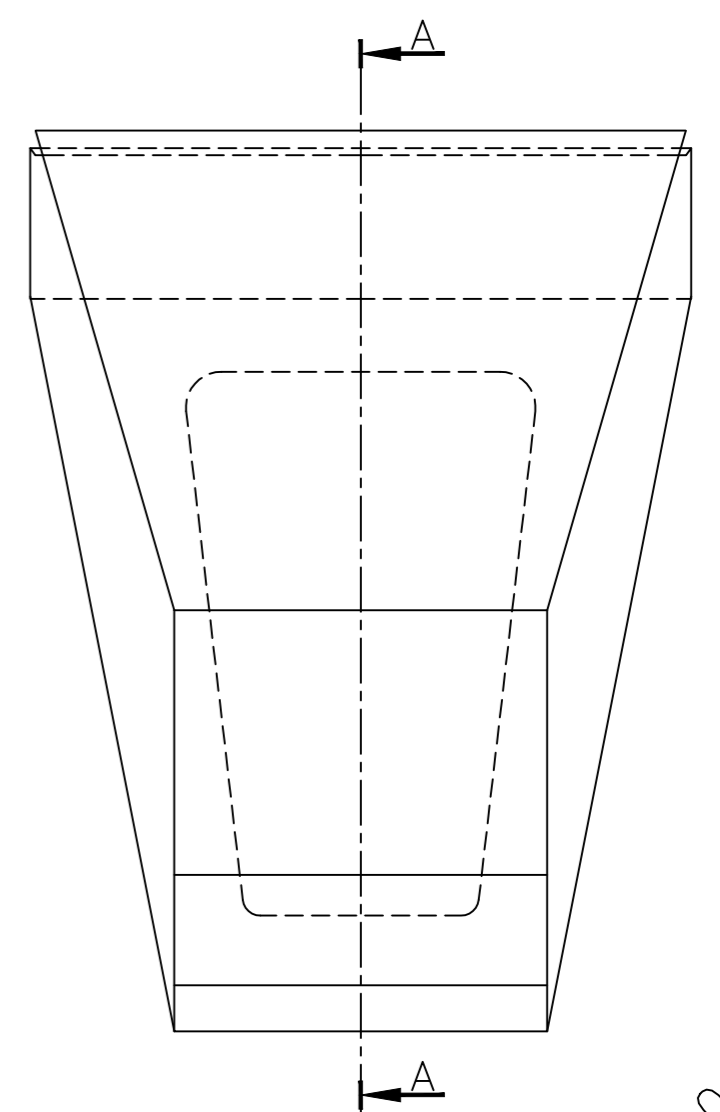
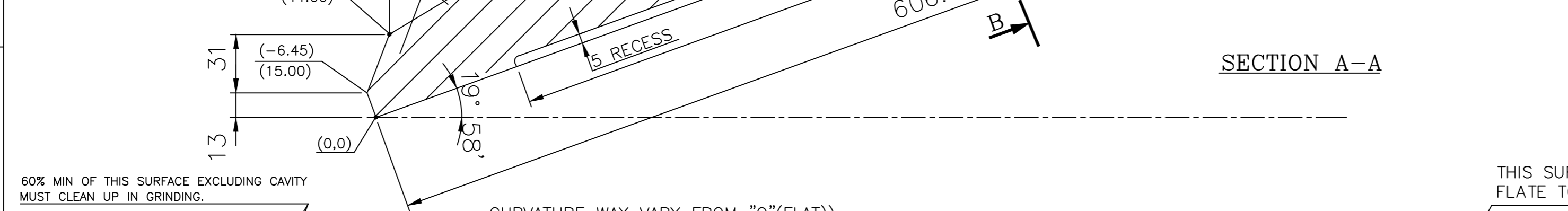
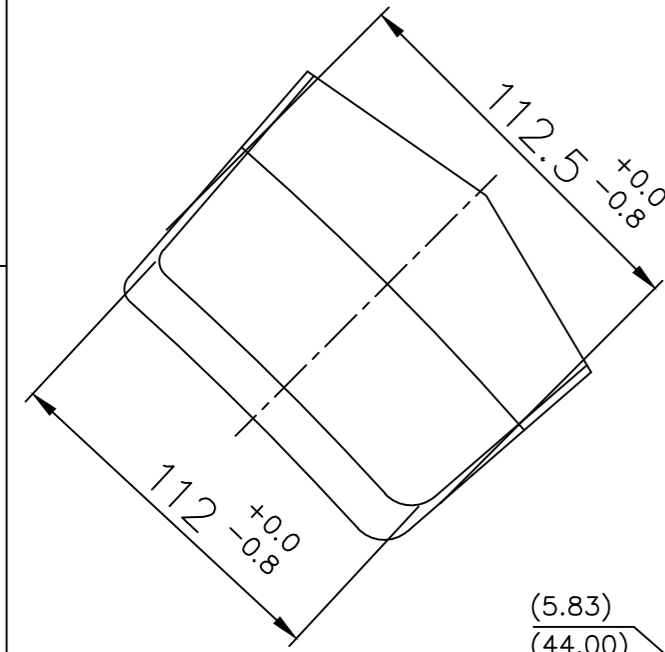

60% MIN OF THIS SURFACE EXCLUDING CAVITY MUST CLEAN UP IN GRINDING.

CURVATURE WAY VARY FROM "O"(FLAT)) TO TRUE RADIUS.

THIS SURFACE TO BE FLATE TO 0.8 MAX.CONCAVE.

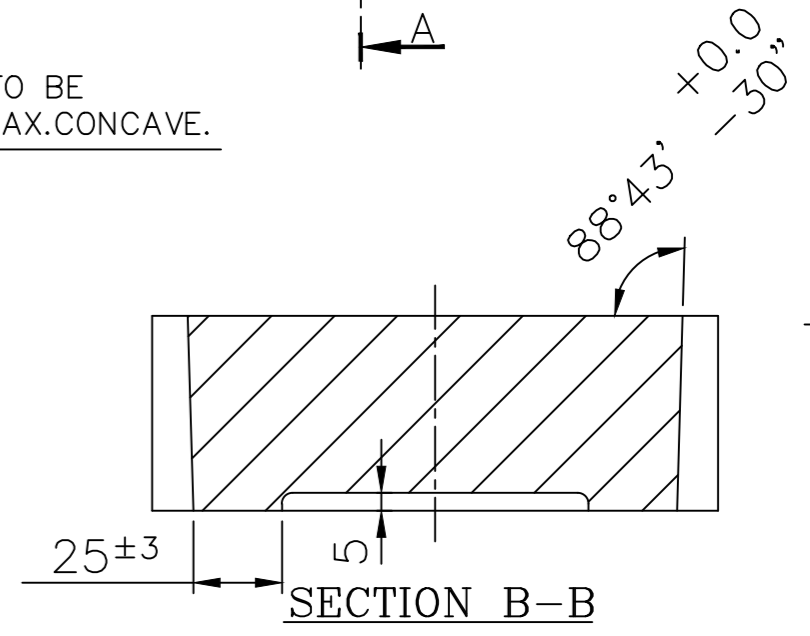
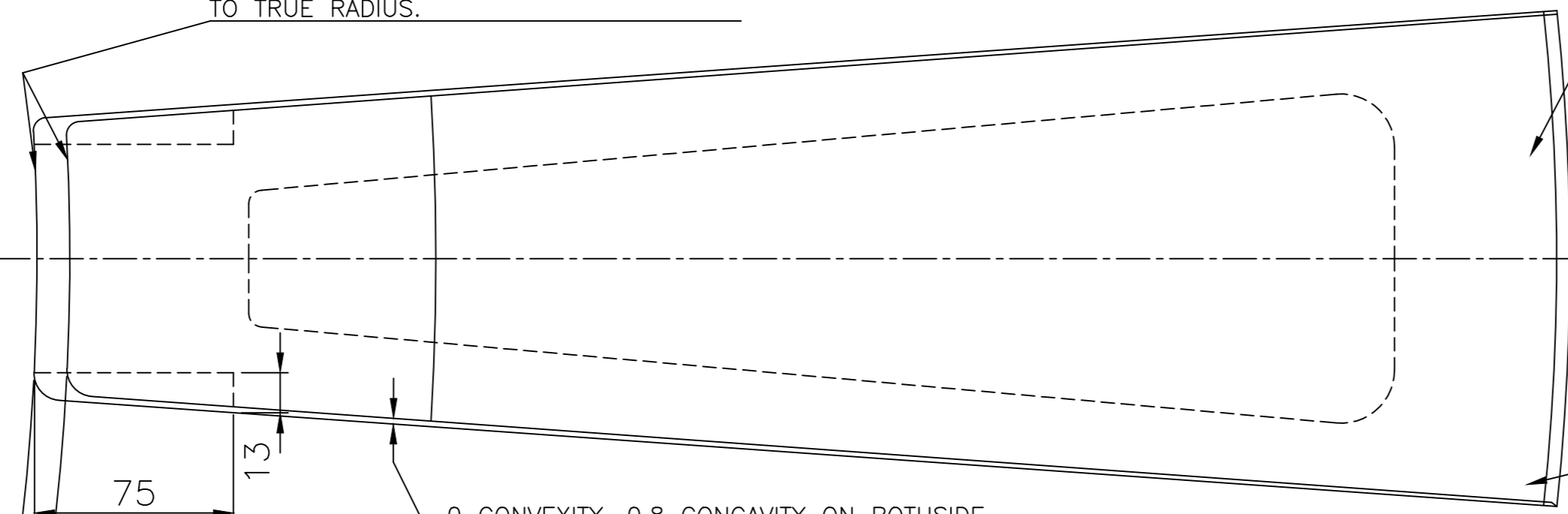
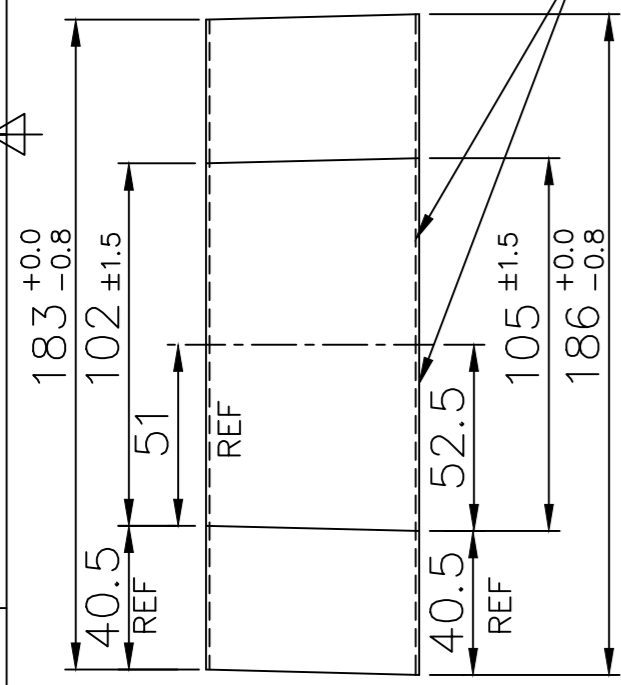

ATLEST 90% OF EACH CORNER AREA MUST CLEAN UP 4PLACES

R860.5 MAX.  
R879.5 MAX.

NOTE:-  
1. PATTERN NO. M-67-468

01	CASING		01	BA9117053374	43.00	
				HY 19770		1
ITEM NO	DESCRIPTION	DRAWING NO.	VAR. NO.	RAW MATERIAL SIZE OR CASTING DRG.NO. OR FORGING DRG.NO.	MATERIAL CODE	NET WT. GROSS WT.
					MATERIAL SPECN.	QUANTITY

THE FOLLOWING CONDITIONS APPLY EXCEPT OTHERWISE STATED...

- REF.TO HY0230261 FOR UNSPECIFIED TOLERANCES.
- CHAMFER M/CD SHARP EDGES 1.2 TO 1.0 AT 45°.
- INTERNAL M/CD CORNER RADII 1 TO 0.7.
- THE SURFACE ROUGHNESS WHEREVER NOT SHOWN SHALL BE TAKEN FROM THE SURFACE ROUGHNESS SHOWN OUT SIDE BACK SLASHES GIVEN AT THE TOP MOST RIGHT CORNER OF THE DRG.

TYPE OF PRODUCT OR NAME OF CUSTOMER/PROJECT

**BHARAT HEAVY ELECTRICALS LTD.**  
HYDERABAD

NAME	SIGN.	DATE	NO.OF VAR.
DRN. RAZVI		20.1.12	
CHD. AMAN		20.1.12	NA
APPD. S.G.G		20.1.12	

DEPT. ENGG. UNTO. DIMS. GR. CODE 446 2/M/F

SCALE 1:2 WEIGHT (KG) 10.00 REF. TO ASSY. DRG. ITEM NO. NO.OF ITEMS

TITLE **BULL RING SEGMENT PLAIN (MOD PROFILE)**

DRAWING NO. 2-61-104-02339 03  
SHT. No 01 NO. OF SHT. 01

REV.	DATE	ALTERED	REV.	DATE	ALTERED	REV.	DATE	ALTERED	REV.	DATE	ALTERED
		CHD/APPD			CHD/APPD			CHD/APPD	03	20.1.12	CHD/APPD AMAN/S.G.G
ZONE			ZONE			ZONE			ZONE		DRAWING REDRAWN. INCORPORATING ALL PREVIOUS REVISIONS.

INVENTORY NO. SIGN. AND DATE REF. DRG. NO. COMPUTER FILE NAME 26110402339-S00-R03 THE INFORMATION ON THIS DOCUMENT IS THE PROPERTY OF BHARAT HEAVY ELECTRICALS LIMITED. IT MUST NOT BE USED DIRECTLY OR INDIRECTLY IN ANY WAY DETRIMENTAL TO THE INTEREST OF THE COMPANY