



Bharat Heavy Electricals Limited

(A Govt. of India Undertaking)

Power Plant Piping Unit, Thirumayam – 622 507, Tamil Nadu

Tender Notice

NOTICE INVITING e-TENDER

Ref: Tender No. PPPU: WC: 26: 008 dt. 13.06.2026.

Subject: Two-part e-Tender inviting techno-commercial and price bids for “Preheating, Post heating and Local Post Weld Heat Treatment by resistance heating at PPPU, Thirumayam”

Kindly submit your competitive offer for the above subject work as per the tender terms and conditions given in the tender document through GEM portal <https://gem.gov.in/> only.

Scope of work	Preheating, Post heating and Local Post Weld Heat Treatment by resistance heating at PPPU, Thirumayam (Scope of work and technical terms & conditions as per Techno-Commercial Part-I bid.)
Location of work	BHEL PPPU Thirumayam -622507 (Tamilnadu)
Date / Time of Pre Bid Meeting	10:30 AM on 17.06.2026 via Webex Meeting link: https://bhel.webex.com/bhel/j.php?MTID=mdd5a2001e38ae35e2c87bb9e7f75c9db Meeting number: 2514 039 3384 Meeting password: a6GZEsUpX27
Duration of Contract	12 Months from the date of commencement of work as indicated in LOI.
Last date/ time for receipt of tender	Date and Time as indicated in GeM Portal
Commencement of work	On the date of commencement mentioned in the LOI
Date / Time & place for opening of Techno-commercial bids	Date and Time as indicated in GeM Portal via On line through GeM by Contracts, PPPU, Thirumayam (In case of any change in opening date, if any, will be intimated later.)
Date/Time of Price Bid Opening	The date/ time of price bid opening will be intimated separately.
EMD AMOUNT	Rs. 2,00,000/- (Rupees Two Lakhs only)
Working Area Contact details	Manager / OP&C Power Plant Piping Unit, BHEL -Thirumayam – 622507, Contact No. 04333-279277, 7598266535 Email ID: dhileeban@bhel.in Vendors may visit the work area prior to submission of offer to understand the details of scope of work

Place:
Date:

Signature of Authorized Signatory
with seal & full address



Bharat Heavy Electricals Limited

(A Govt. of India Undertaking)

Power Plant Piping Unit, Thirumayam – 622 507, Tamil Nadu

Tender Notice

Buyer Added Bid Specific Additional Terms & Conditions (ATC)

1. PRE QUALIFICATION CRITERIA:

1.1. TECHNICAL:

1.1.1. STATUS OF THE COMPANY:

- Proprietorship: PAN card on owner name
- For partnership firms: PAN card and PARTNERSHIP DEED
- For others: PAN card in the name of company / firm / business and CERTIFICATE OF INCORPORATION / MOA and AOA.
- GST Registration certificate

*As per point no. 1.5 of GCC.

1.1.2. PROOF OF EXPERIENCE:

The Bidder / Vendor shall have either of the following three experience executed after 31st of March 2018:

- a) 3 similar completed works costing each not less than Rs 58 lakhs
or
- b) 2 similar completed works costing each not less than Rs 72 lakhs
or
- c) 1 similar completed work costing not less than Rs 115 lakhs

Similar work means Similar works means " PRE HEATING, POST HEATING OF PIPE BY RESISTANCE HEATING METHOD or any Controlled Heat Treatment cycle".

Proof of Work Order / Purchase Order/ Experience certificate should be attached. Proof of experience from any organization other than BHEL to be supported by TDS (Tax Deducted at Source) certificate issued by the organizations OR Form 26 AS or bank statement for transaction of payment.

1.1.3 Tender document (all pages) & Duly filled Checklist (Annexure-1) to be Signed & seal by bidder's Authorized signatory along with annexures.[Digital sign on first page or Manual sign and seal on all pages]

1.1.5 No deviation certificate on bidder's Letter head

1.1.6 Local Content Self Declaration on bidder's Letter head

Place:
Date:

Signature of Authorized Signatory
with seal & full address



Bharat Heavy Electricals Limited

(A Govt. of India Undertaking)

Power Plant Piping Unit, Thirumayam – 622 507, Tamil Nadu

Tender Notice

2 SCOPE OF SUPPLY, Technical terms & Conditions:

2.1 Scope:

1. Contractor shall bring the HT equipment/facilities for conducting **LOCALISED PRE HEATING & POST HEATING OF PIPE and POST WELD HEAT TREATMENT BY RESISTANCE HEATING METHOD** at BHEL-PPPU/Thirumayam. Persons conducting the HT should be aware of welding processes and maintain the equipment's properly for heat input. Mainly the material categories are Carbon Steel: ASME A106 Gr B / Gr C, Low Alloy: ASME A335P11, P12 & P22 & High Alloy (CSEF): ASME A335 P91 / P92 steels. Job Diameter (OD) may range from 33.4 mm to 1118 mm. Job Thickness may range from 5.49 mm to 125 mm. Various specification involved are SA106GRB/GRC, SA335P12/P22/P91/P92, etc.

Period of contract is 12 months.

2. Vendor shall be approved by IBR for carrying out Heat Treatment of above mentioned specifications.

3. Vendor shall bring the required heating equipment for **PRE HEATING, POST HEATING, POST WELD HEAT TREATMENT OF PIPE BY RESISTANCE HEATING** and it shall be in the scope of the vendor. All the HT equipments' accessories required for the machines, consumables like heating coils, insulation wool, cables, Thermocouples, etc. temperature monitoring instruments that are required for maintaining/checking the desired temperature are in the scope of the vendor.

4. The contractor should keep all his equipment & accessories (Power source, coils and consumables such as ceramic fiber blankets, recorder chart papers, etc.) in PPPU-BHEL Thirumayam premises throughout the contract period or quantity of contract completion, whichever is earlier.

5. The following shall be made available for executing the work and sufficient manpower shall be deployed during the period as mentioned above Sl. No.4:

It is estimated 12 sets of power sources & corresponding accessories shall be made available with sufficient spare sets in each equipment to cater simultaneous load for the carrying out resistance heating as per tender. This may vary based on the load/jobs.

6. All the equipment and applicable tools/instruments shall be calibrated by approved agency throughout the contract period.

7. Intimation shall be provided one day in advance.

Place:
Date:

Signature of Authorized Signatory
with seal & full address



Bharat Heavy Electricals Limited

(A Govt. of India Undertaking)

Power Plant Piping Unit, Thirumayam – 622 507, Tamil Nadu

Tender Notice

Heating cycle involves the following elemental operations:

a) Winding of resistance coils around the welding location with insulation for 300mm on either side of weldment. The number of "turns" (wraps) is calculated based on the pipe diameter and wall thickness to ensure the Heat Affected Zone (HAZ) is fully covered.

b) Ensure the connection to the appropriate power source.

c) Maintain the pre-heat temperature and post heat temperature as per SQP: PP:06. Repeat the heating cycle when power interruption occurs as per the above procedures. Temperature display shall be available for monitoring/checking.

d) Vendor shall maintain the Preheating setup in wound condition until welding is completed to carryout Post Heating.

e) For Post Weld Heat Treatment, the following shall be arranged in addition to winding the coil:

i) Providing of thermocouple arrangement to the job, recorder & controller. Vendor shall bring 6-point recorder (minimum) for conducting PWHT and it shall be capable to do 6 recordings in a single cycle (. i.e. it shall be capable of connecting 6 Thermocouples)

ii) Calibration of the recorder and recorder setting to ensure the required HT temperature at root of the joint (ID).

iii) Ensure the connection to the appropriate power source.

iv) Maintain rate of heating, soaking time and rate of cooling during HT cycle. Repeat the cycle when power interruption occurs.

v) Preparation of HT chart and getting it cleared by BHEL /QC

For PWHT of Carbon Steel/Alloy Steel, the Job OD may range from 33.4 to 1114 mm. Thickness may range from 5.49 mm to 125 mm.

For PWHT of P91/P92, Job Thickness may vary from 30 mm to 125 mm.

Place:
Date:

Signature of Authorized Signatory
with seal & full address



Bharat Heavy Electricals Limited

(A Govt. of India Undertaking)

Power Plant Piping Unit, Thirumayam – 622 507, Tamil Nadu

Tender Notice

f) Post Weld Heat Treatment temperature for different materials are given below:

Base pipe material spec.	Post Weld HT temperature
SA106GRC (any thickness)	610 +/-15 deg C
SA335P11 / P12 (any thickness)	655 +/-15 deg C
SA335P22 (any thickness)	695 +/-15 deg C
SA335P91/92 (up to 25mm thickness)	760 +/-10 deg C

g) Soaking Time for PWHT are given below

1 Hour per inch of pipe thick / maximum weld size whichever is higher

h) Rate of Heating / Cooling for PWHT

Rate of heating / cooling for SR(/PWHT) shall be as below unless otherwise specified. Incase of SR(/PWHT), cooling shall be up to 400 deg. C (350 deg. C for P91, P91+P22, P92, P92+P91,) and further in Air.

Thickness of Material	Maximum Rate of Heating & Cooling above 400 deg. C
Up to 25mm	220°C/Hr
Over 25 - 50mm	110°C/Hr
Over 50 - 75mm	75°C/Hr
Over 75mm	55°C/Hr

Heating and cooling rates for PWHT of P91/P92 materials shall not exceed 140°C/hour above 350°C.

The exact parameters of PWHT for each job will be provided by respective shop with reference to Operation Process Sheet or Quality plan.

i) Local Heat Treatment (PWHT) shall be carried out as per document Quality Control Procedure for Local Heat Treatment , QCP:12, Rev 00

j) Half peak temperature for PWHT: In addition to the above, the following clause from EN 12952 Part 5, Cl. 10.4.2.3 shall be followed so that the Half peak temperature is maintained upto the Heat Affected zone mentioned in the standard.

Sufficient insulation shall be fitted to ensure that the temperature of the weld and its heat affected zone is not less than that specified and that the temperature at a distance of 2.5 X vris eis from the centre line of the weld is not less than the half peak temperature. In addition, the adjacent portion of the

Place:
Date:

Signature of Authorized Signatory
with seal & full address



Bharat Heavy Electricals Limited

(A Govt. of India Undertaking)

Power Plant Piping Unit, Thirumayam – 622 507, Tamil Nadu

Tender Notice

component outside the heated zone shall be thermally insulated such that the temperature gradient is not harmful.

In essence, the TC fixed at $2.5 \sqrt{(D/2)} \times T$ from weld centre shall not read less than the half-peak, where D is the Diameter of the Job and T is the thickness of the job.

k) Preparation of temperature chart and getting it cleared by BHEL authorized personnel.

l) Vendor shall plan for alternate manpower in case of absenteeism for executing the work and shall be deployed until the total process is completed

m) Necessary care should be exercised to cover up maximum possible attachments considering HAZ in single winding to increase productivity. Such heating activity shall be considered as one unit and to be processed accordingly for billing.

8. The pipe range for LOCALISED PRE HEATING, POST HEATING shall be as below. Interpass temperature* has to be maintained as per applicable WPS(Welding Procedure Specification), so that temperature gradient is maintained throughout the welding cycle.

*APPLICABLE FOR P91/92 ALLOY STEEL BASED ON SQP PP 06. Base Outer diameter of the job will be considered for calculation of the "DIA IN INCHES". Pre/Post Heating carried out for each welding area/weldment will be considered separately. Local PWHT will be paid on number of cycles being operated.

Working hours

One shift means EIGHT hours duration (excluding Lunch/Dinner breaks) as mentioned below

G Shift (General): 08.00 AM to 04.30 PM

N Shift (Night): 04.30 PM to 01.00 AM (next day)

Depending upon the available HT cycle, the following shift will also be operated with advance notice.

A Shift: 06.00 AM to 02.30 PM

B Shift: 02.00 PM to 10.30 PM

C Shift: 10.00 PM to 06.30 AM (next day)

General Conditions:

1. On award of contract the bidder has to produce the following before commencement of work.

- i) For Supervisors & Technicians: Previous experience for having carried out Localised Heat Treatment at any project site or any other establishment. Relevant experience shall be certified by the contractor
- ii) For Helpers: Helpers who have worked on similar work are required. Relevant experience shall be certified by the contractor

2. The nature of work will vary from time to time depending on the shop-floor loading, leading to change in the requirement of Heat Cycle with likely condition of break in service requirement and change in operating shifts, but with advance information from BHEL side.

Place:

Date:

Signature of Authorized Signatory
with seal & full address



Bharat Heavy Electricals Limited

(A Govt. of India Undertaking)

Power Plant Piping Unit, Thirumayam – 622 507, Tamil Nadu

Tender Notice

3. The requisite man power for completing the informed/assigned work, shall be deployed within the time frame indicated.
4. Shift-wise attendance register with IN and OUT timing shall be maintained by the supervisor and shall be countersigned by the BHEL Staff, at the end of each shift of duty.
5. The workmen deployed shall wear uniform (as provided by the contractor), Industrial safety shoes, industrial helmet, safety goggles, hand gloves, respirator and identification card during the hours of engagement within BHEL plant premises.
6. The contractor shall provide the above PPEs at their cost. The contractor is also responsible for enforcing safety requirements among their workmen.
7. The age of the individual shall be between 18 yrs. and 60 yrs.
8. The individual shall be ready to work in an industrial environment & abide by the rules and regulations of BHEL.
9. The contractor should bring contract labour to BHEL premises at his/her own cost, risk and execute the work allotted to him in BHEL premises.
10. The contractor should follow and comply with Minimum wages, ESI, PF, Bonus and other statutory regulations as stipulated in Factories Act and other applicable State/Central Governments' rules and regulations.
11. All safety equipments to the workmen, safety rules and regulations are to be followed as per BHEL's Safety Rules and Regulations.
12. BHEL will be no way responsible for any loss of life or any injury caused to any of the contractors or their crew while executing the above work at BHEL premises.
13. The contractor or his/her crew should handle the machinery and other equipment's entrusted to them by BHEL with utmost care and return them safely after execution of stipulated work. The cost of damage, repair due to improper handling of machinery and equipment will be recovered from the contractor.
14. Contractor shall supervise the work carried out by his/her employees.

Place:
Date:

Signature of Authorized Signatory
with seal & full address



Bharat Heavy Electricals Limited

(A Govt. of India Undertaking)

Power Plant Piping Unit, Thirumayam – 622 507, Tamil Nadu

Tender Notice

15. Contractor shall ensure that the employees deployed in the premises of BHEL are physically and mentally fit and do not have any criminal record. Such employees should possess requisite skill, proficiency, qualification, experience etc.
16. Contractor shall maintain appropriate records of his/her employees deployed to carry out the job(s).
17. Contractor will be responsible for the good conduct of his/her employees. In case of any misconduct/misbehavior by any employee, the contractor will replace such employee(s) immediately.
18. Contractor will ensure that the job is executed through his/her employees on and under no circumstances, the contractor will not deploy any casual employee to carry out the job nor shall subcontract the job without prior written permission.
19. Contractor shall be solely responsible for non-payment, delayed payment of minimum contributions under EPF and MP Act, ESI Act, Bonus, etc.
20. In case, the contractor fails to make payment of wages to his/her employees or remittance of contribution to the concerned authorities, the security deposit, other dues/running bills under the contract can be utilized by BHEL to discharge the liability of the contractor.
21. The liability for any compensation on account of injury sustained by an employee of the contractor will be exclusively that of the contractor.
22. Contractor shall observe provisions of the Factories Act, 1948 in respect of working hours, holidays, rest intervals, leave and overtime to his/her employee. No work shall be done in shifts other than mentioned above, overtime, Sundays or on other declared holidays without written permission.
23. The contractor should maintain a 'Work Diary containing the details of work executed by him from time to time on Shift/Daily basis and obtain the signature from official concerned nominated for this/her purpose for having executed the work correctly and satisfactorily.
24. The proof of execution of work should be submitted along with each bill (printed form with covering letter and proof for execution of work).
25. The GST compliant Tax invoice shall be submitted in Triplicate for bill clearance along with originals of PF clearance certificate by HR, countersigned attendance and a copy of all documents to executing agency. The bill should be submitted within a week after execution of work during the calendar month @one bill per month. Kindly note all the payments to the contract employees and PF/ESI must be through EFT and supporting documents like bank account statements and challans for PF clearance must be produced. Proof of payment of taxes to be submitted along with bill.

Place:
Date:

Signature of Authorized Signatory
with seal & full address



Bharat Heavy Electricals Limited

(A Govt. of India Undertaking)

Power Plant Piping Unit, Thirumayam – 622 507, Tamil Nadu

Tender Notice

26. On submission of error free bill, the bill will be processed and payment will be made by BHEL as per BHEL Standard terms.

27. Necessary gate entry pass will be issued by BHEL Security department for Contract Workmen based on your application duly forwarded by the Contract Executing Department and approved by HR/Welfare/Contract Cell on fulfilment of the Statutory Obligation by the Contractor.

28. In the event of termination of contract for any reason whatsoever, the contractor shall withdraw all his/her employees from the establishment of BHEL. In case, contractor decides to terminate services of his/her employees, he should settle all terminal dues including retrenchment compensation.

29. The Contractor may visit BHEL Premises before quoting to assess the quantum of work.

30. Applicable Taxes, if any should be mentioned separately.

31. BHEL reserves the right to cancel/short close and terminate the contract at any point of time after giving intimation to the vendor.

General Terms and Conditions:

BHEL will have nothing to do or be concerned with the employment of employees working for the contractor. The relationship between BHEL and the contractor will be that of independent entities and nothing herein contained will amount to joint venture, partnership or on employer-employee relationship. Supervision of work shall be done by the contractor / his authorized Supervisor exclusive for this work only.

Place:
Date:

Signature of Authorized Signatory
with seal & full address



Bharat Heavy Electricals Limited

(A Govt. of India Undertaking)

Power Plant Piping Unit, Thirumayam – 622 507, Tamil Nadu

Tender Notice

2.2 BILL OF QUANTITY:

Sl no	Description of Activity	TOTAL DIA IN INCHES (UOM in INCHES)	Quantity	Percentage Allocation
1	Preheating of pipes using resistance heating equipment OD 1.3 TO 20 INCHES	Inches	32827	21.04
2	Preheating of pipes using resistance heating equipment OD 20.1 TO 44.1 INCHES	Inches	38448	27.38
3	Post heating of pipes using resistance heating equipment OD 1.3 TO 20 INCHES	Inches	32827	9.35
4	Post heating of pipes using resistance heating equipment OD 20.1 TO 44.1 INCHES	Inches	38448	13.69
5	Local Post Weld heat Treatment using Resistance method OD<=20 INCH,THICKNESS<=50mm	Inches	14141	7.05
6	Local Post Weld heat Treatment using Resistance method OD<=20 INCH,THICKNESS>50mm	Inches	19318	12.52
5	Local Post Weld heat Treatment using Resistance method OD>20 INCH,ANY THICKNESS	Inches	11998	8.97

The above quantity may vary up to +/- 30% .

**Bidder shall quote lumpsum rate (inclusive of GST) for a period of 12 months in GeM Portal after going through the scope of work in tender document.*

**Bills shall be raised after completion of each month (inclusive of GST).*

Place:
Date:

Signature of Authorized Signatory
with seal & full address



Bharat Heavy Electricals Limited

(A Govt. of India Undertaking)

Power Plant Piping Unit, Thirumayam – 622 507, Tamil Nadu

Tender Notice

ITEM RATE CALCULATION:

Contractor shall only quote the total amount for the work and not the individual rates for every item of BOQ.

The rates for the individual items of BOQ would be arrived by BHEL as follows

Assuming the amount quoted by vendor is ₹ 1,00,00,000/- (Rupees One crore only)

" Amount allocated for quantity stated in item 1 (Preheating of pipes using resistance heating equipment OD 1.3 TO 20 INCHES) would be = 21.04% X 1,00,00,000 (since % allocation in BOQ is 21.04% for this item) i.e. ₹ 21,04,000/-"

Hence, rate of Item 1 would be $2104000/32827$ (Amount allocated for item1/Quantity of item1) = ₹ 64.09/-

"The rates will be rounded off to nearest two decimal places only, so as to match the total amount or closest to the total amount, quoted by the vendor. Rates so arrived by BHEL shall be final and binding on the contractor."

Similarly, rates of other items shall be calculated.

NOTE:

"The Vendor has to quote lump sum / package value only. Individual rates for each item shall be arrived based on % allocation for each item. Illustration for arriving at unit rate is detailed above. "

Tender Price:

- Unless explicitly stated in the tender document, the contractor shall be responsible for the whole works, based on the schedule of works, bill of quantities and payment shall be made as per accepted rates based on the activities carried out as in the scope of work.
- While quoting the "service charge", bidders should consider all cost elements like financing cost, cost of maintenance of accounts, insurance-premium overheads, profit margins, conveyance charges, amount of security deposit, statutory requirements / obligations, contractual obligations and any other expenditure as deemed relevant by the bidder or cost of any other item under its scope and to meet any expenses / exigencies (including bearing of penalty by bidder as per tender document) so as to ensure continuity of services. While quoting the price, the bidder must keep in view the prevailing applicable minimum wages of the Government of Tamilnadu. It is the responsibility of the bidder to educate himself about all obligations to be performed under the contract, the financing cost, administrative expenses, statutory liabilities, etc and then submit the price accordingly.

Place:
Date:

Signature of Authorized Signatory
with seal & full address



Bharat Heavy Electricals Limited

(A Govt. of India Undertaking)

Power Plant Piping Unit, Thirumayam – 622 507, Tamil Nadu

Tender Notice

- c) The Minimum Wages as prescribed by the State Government from time to time should be paid to the contract Workers and the Wage and Attendance Registers should be produced to HR department every month.

The minimum wages are given below for reference: (w.e.f 01/04/2026)

Sl. No.	Category	Minimum Wages per day (Rs.)		
		Basic	DA	Total
1	Unskilled Worker	258.50	298.07	556.57
2	Semi-Skilled Worker	271.00	298.07	569.07
3	Skilled Worker	278.50	298.07	576.57
4	Supervisor	295.00	298.07	593.07

(The above table is for illustrative purpose only. Latest Govt circular shall be followed.)

2.3 Applicable Contractual Variations

Within the validity or any extension of contract thereof, “Service charge” shall remain Firm (in terms of value) without any escalation / variation for any reason, whatsoever, unless specifically provided herein. Contractor’s obligation shall remain unaffected by such escalation / variation. However, during the validity of contract period, the contract value will vary depending on the followings:

- Rates of basic plus VDA (subsequent to floating of this tender), as & when notified by Govt. of Tamilnadu will be applicable in the contract and accordingly the monthly bills of the contractor will get amended against the documentary evidence.
- Rates of EPF / EPS / EDLI / ESI /Min. monthly bonus etc. (subsequent to floating of this tender), as & when notified by governing statutory authorities will be applicable in the contract and accordingly the monthly bill(s) of the contractor will get amended against the documentary evidence.

2.4 Evaluation criteria: Splitting of contract is not applicable to this work, hence, package wise L1 will be decided and contract will be awarded for the full / complete work.

2.5 Payment Terms

Payment will be made after successful completion of work once in a month.

- Bill will be processed on submission of error free GST rule compliant tax invoices and necessary welfare clearance if any.
- Invoice shall indicate W.O, W.O Sl. No, period of work etc. in all invoices for processing payment.
- After completion of the work, the contractor has to submit the original bills in triplicate.
- The payments will be released by BHEL on submission of error-free bill by the contractor and certification by BHEL in-charge.

Place:
Date:

Signature of Authorized Signatory
with seal & full address



Bharat Heavy Electricals Limited

(A Govt. of India Undertaking)

Power Plant Piping Unit, Thirumayam – 622 507, Tamil Nadu

Tender Notice

Note: Three copies of GST rule compliant tax invoice with original signature to be submitted on completion of work.

e) The bill will be processed and payment will be made by BHEL after number of days mentioned below (depending on type of bidder) from CRAC/SDA:

(i) 90 days for Non MSME Vendors, (ii) 60 days for Medium vendors & (iii) 45 days for MSE vendors

Together with the points mentioned above, please note the following when submitting invoices. For goods / works / services on Indian Suppliers / Contractors: Irrespective of the value of the invoice amount, the supplier/ contractor should necessarily upload the invoice details on BHEL SUVIDHA portal at <https://suvidha.bhel.in/suvidha/>, prior to despatch/raising invoice. All documents as per contract checklist, along with additional documents (if any), must be uploaded on the portal. It is mandatory that tax invoices with a net amount (including taxes) exceeding Rs five lakhs uploaded on the portal are digitally signed using a Class 3 Digital Signature Certificate (DSC) issued by a licensed Certifying Authority. Submission of invoice document in hard copy is allowed for invoices with a net amount (including taxes) equal to and upto Rs five lakhs in case the requirement for digitally signed invoice is not explicitly mentioned in the contract checklist. The Invoice will not be accepted in absence of the above.

However, GST amount shall be reimbursed in line with compliance to Cl. No. 4 (Taxes & Duties) above. No Interest payable to Contractor & No interest shall be payable on the security deposit or any other money due to the contractor.

2.6 Liquidated Damages (LD) / Penalty

a) If the contractor is unable to start the work at BHEL - PPPU within 1 day from the date of intimation, then a fine of Rs. 1000/- per day shall be levied for the no of days delayed. This amount shall be deducted from the submitted bill.

b) On further delay (i.e., after 3 weeks), Breach of Contract clause will be operated.

Additionally, penalty as listed in the section "NON COMPLIANCE OF SAFETY RULES" will be levied if contract employees are violating norms.

2.7 POLICE VERIFICATION:

The Police Verification Certificate of each contract worker engaged to be submitted along with Contractors Bills during 1st month for clearance. Police verification for any new contract worker engaged during the contract period is mandatory for obtaining permit to work inside factory premises.

Place:
Date:

Signature of Authorized Signatory
with seal & full address



Bharat Heavy Electricals Limited

(A Govt. of India Undertaking)

Power Plant Piping Unit, Thirumayam – 622 507, Tamil Nadu

Tender Notice

2.8 **CONTRACT PERIOD:**

1. The Contract Execution period will be 12 Months from the date of commencement of work as stated in LOI.
2. If required, BHEL reserves the right to extend this subject contract for a further period under same terms and conditions subject to mutual acceptance of both parties.
3. If at any time after the award of contract, BHEL shall for any reason whatsoever not require whole or any part of the work to be carried out, the same shall be communicated to the Contractor and the contract shall be closed.

3 **PRICE BASIS:**

Not applicable

4 **TAXES & DUTIES:**

- 4.1 The Supplier/Vendor shall pay all (save the specific exclusions as enumerated in this clause) taxes, fees, license, charges, deposits, duties, tools, royalty, commissions, other charges, etc. which may be levied on the input goods & services consumed and output goods & services delivered in course of his operations in executing the contract. In case BHEL is forced to pay any of such taxes/duties, BHEL shall have the right to recover the same from his bills or otherwise as deemed fit along with the applicable overheads @5% and interest on the total value (i. e. amount paid by BHEL + overhead)

However, provisions regarding **GST** on output supply (goods/service) and TDS/TCS as per Income Tax Act shall be as per following clauses.

4.2 **GST (Goods and Services Tax)**

- 4.2.1 GST as applicable on output supply (goods/services) are excluded from Supplier/Vendor's scope; therefore, contractor's price/rates shall be **exclusive** of GST. Reimbursement of GST is subject to compliance of following terms and conditions. BHEL shall have the right to deny payment of GST and to recover any loss to BHEL on account of tax, interest, penalty etc. for non-compliance of any of the following condition.
- 4.2.2 The admissibility of GST, taxes and duties referred in this chapter or elsewhere in the contract shall be limited to direct transactions between BHEL & its Supplier/Vendor. BHEL shall not consider GST on any transaction other than the direct transaction between BHEL & its Supplier/Vendor.
- 4.2.3 Supplier/Vendor shall obtain prior written consent of BHEL before billing the amount towards such taxes. Where the GST laws permit more than one option or methodology for discharging the liability of tax/levy/duty, BHEL shall have the right to adopt the appropriate one considering the amount of tax liability on BHEL/Client as well as procedural simplicity

Place:
Date:

Signature of Authorized Signatory
with seal & full address



Bharat Heavy Electricals Limited

(A Govt. of India Undertaking)

Power Plant Piping Unit, Thirumayam – 622 507, Tamil Nadu

Tender Notice

with regard to assessment of the liability. The option chosen by BHEL shall be binding on the Contractor for discharging the obligation of BHEL in respect of the tax liability to the Supplier/Vendor.

- 4.2.5 Supplier/Vendor has to submit GST registration certificate of the concerned state. Supplier/Vendor also needs to ensure that the submitted GST registration certificate should be in active status during the entire contract period.
- 4.2.6 Supplier/Vendor has to issue Invoice/Debit Note/Credit Note indicating HSN/SAC code, Description, Value, Rate, applicable tax and other particulars in compliance with the provisions of relevant GST Act and Rules made thereunder.
- 4.2.7 Supplier/Vendor has to submit GST compliant invoice within the due date of invoice as per GST Law. In case of delay, BHEL reserves the right of denial of GST payment if there occurs any hardship to BHEL in claiming the input thereof. In case of goods, Supplier/Vendor has to provide scan copy of invoice & GR/LR/RR to BHEL before movement of goods starts to enable BHEL to meet its GST related compliances. Special care should be taken in case of month end transactions.
- 4.2.8 Supplier/Vendor has to ensure that invoice in respect of such services which have been provided/completed on or before end of the month should not bear the date later than last working day of the month in which services are performed.
- 4.2.9 Subject to other provisions of the contract, GST amount claimed in the invoice shall be released on fulfilment of all the following conditions by the Supplier/Vendor: -
- Supply of goods and/or services have been received by BHEL.
 - Original Tax Invoice has been submitted to BHEL.
 - Supplier/Vendor has submitted all the documents required for processing of bill as per contract/ purchase order/ work order.
 - In cases where e-invoicing provision is applicable, Supplier/Vendor is required to submit invoice in compliance with e-invoicing provisions of GST Act and Rules made thereunder.
 - Supplier/Vendor has filed all the relevant GST return (e.g. GSTR-1, GSTR-3B, etc.) pertaining to the invoice submitted and submit the proof of such return along with immediate subsequent invoice. In case of final invoice/ bill, contractor has to submit proof of such return within fifteen days from the due date of relevant return.
 - Respective invoice has appeared in BHEL's GSTR - 2A for the month corresponding to the month of invoice and in GSTR-2B of the month in which such invoices has been reported by the contractor along with status of ITC availability as "YES" in GSTR-2B. Alternatively, BG of appropriate value may be furnished which shall be valid at least one month beyond the due date of confirmation of relevant payment of GST on GSTN portal or sufficient security is available to adjust the financial impact in case of any default by the Supplier/Vendor.

Place:
Date:

Signature of Authorized Signatory
with seal & full address



Bharat Heavy Electricals Limited

(A Govt. of India Undertaking)

Power Plant Piping Unit, Thirumayam – 622 507, Tamil Nadu

Tender Notice

- g) Supplier/Vendor has to submit an undertaking confirming the payment of all due GST in respect of invoices pertaining to BHEL.
- 4.2.10 Any financial loss arises to BHEL on account of failure or delay in submission of any document as per contract/purchase order/work order at the time of submission of Tax invoice to BHEL, shall be deducted from Supplier/Vendor's bill or otherwise as deemed fit.
- 4.2.11 TDS as applicable under GST law shall be deducted from Supplier/Vendor's bill.
- 4.2.12 Supplier/Vendor shall comply with the provisions of e-way bill wherever applicable. Further wherever provisions of GST Act permits, all the e-way bills, road permits etc. required for transportation of goods needs to be arranged by the contractor.
- 4.2.13 Supplier/Vendor shall be solely responsible for discharging his GST liability according to the provisions of GST Law and BHEL will not entertain any claim of GST/interest/penalty or any other liability on account of failure of Supplier/Vendor in complying the provisions of GST Law or discharging the GST liability in a manner laid down thereunder.
- 4.2.14 In case declaration of any invoice is delayed by the vendor in his GST return or any invoice is subsequently amended/alterd/deleted on GSTN portal which results in any adverse financial implication on BHEL, the financial impact thereof including interest/penalty shall be recovered from the Supplier/Vendor's due payment.
- 4.2.15 Any denial of input credit to BHEL or arising of any tax liability on BHEL due to non-compliance of GST Law by the Supplier/Vendor in any manner, will be recovered along with liability on account of interest and penalty (if any) from the payments due to the Supplier/Vendor.
- 4.2.16 In the event of any ambiguity in GST law with respect to availability of input credit of GST charged on the invoice raised by the contractor or with respect to any other matter having impact on BHEL, BHEL's decision shall be final and binding on the Supplier/Vendor.

4.2.17 Variation in Taxes & Duties:

Any upward variation in GST shall be considered for reimbursement provided supply of goods and services are made within schedule date stipulated in the contract or approved extended schedule for the reason solely attributable to BHEL. However downward variation shall be subject to adjustment as per actual GST applicability.

In case the Government imposes any new levy/tax on the output service/goods after price bid opening, the same shall be reimbursed by BHEL at actual. The reimbursement under this clause is restricted to the direct transaction between BHEL and its Supplier/Vendor only and within the contractual delivery period only.

In case any new tax/levy/duty etc. becomes applicable after the date of Bidder's offer but before opening of the price Bid, the Bidder/ Supplier/Vendor must convey its impact on his price duly substantiated by documentary evidence in support of the same before opening of price bid. Claim for any such impact after opening the price bid will not be considered by BHEL for reimbursement of tax or reassessment of offer.

Place:
Date:

Signature of Authorized Signatory
with seal & full address



Bharat Heavy Electricals Limited

(A Govt. of India Undertaking)

Power Plant Piping Unit, Thirumayam – 622 507, Tamil Nadu

Tender Notice

4.3 **Income Tax:** TDS/TCS as applicable under Income Tax Act, 1961 or rules made thereunder shall be deducted/collected from Supplier/Vendor's bill.

(5.) SUBMISSION OF BILLS BY CONTRACTOR:

Bills should be submitted within a week after execution of work during the calendar month/ quarter. The Contractor shall submit a bill in triplicate detailing the various items of work done during the month/ quarter supported by the requisitions issued from time to time. The Contractor shall, once in every quarter, submit to the end user / executing agency, separately details of his claims for the work done by him up to and including the previous month which are not covered by his contract agreement in any of the following respects:

- i) Deviation from the items provided in the contract documents.
- ii) Extra items / new items of work.
- iii) Items in-respect of which rates have not been settled. He should in addition furnish a clear certificate to the effect that the claims submitted by him as aforesaid cover all his claims and that no further claims shall be raised by him in respect of the work done up to and including the period under report.
- iv) Along with bills, Contractors has to furnish self-attested copy of the following documents for further processing of bills:
 - v) Copy of PAN card.
 - vi) Documentary proof for payment of PF/ESI (for the last month) with respect to the employees engaged by the contractor with payment details relating to individual names to be submitted.
 - vii) Copy of payment challan of previous Month / Quarter as proof of deposit of GST along with a certificate from the Contractor that tax collected from BHEL has been remitted to tax authorities.
 - viii) If the Contractor is not registered for any statutory obligation and not liable there to, then a declaration shall be submitted along with offer that they are within the threshold limit.

Any other relevant document which is required from time to time as per BHEL requirement.

5 **BANK DETAILS FOR EMD & SECURITY SUBMISSION:** For Electronic Fund Transfer the details are as below:

- a) Name of the Beneficiary: Bharat Heavy Electricals Limited
- b) Bank Particulars (Details of Respectively executing region):
 - Name of the Company – BHEL, Trichy
 - Name of the bank - STATE BANK OF INDIA
 - Bank branch - HEAVY ELECTRICALS, KAILASAPURAM
 - City –Tiruchirappalli Branch code - 01363
 - Account Number – 10891588977
 - Account type – CC

Place:
Date:

Signature of Authorized Signatory
with seal & full address



Bharat Heavy Electricals Limited

(A Govt. of India Undertaking)

Power Plant Piping Unit, Thirumayam – 622 507, Tamil Nadu

Tender Notice

IFSC code - SBIN0001363

MICR code - 620002004

6 BREACH OF CONTRACT, REMEDIES AND TERMINATION:

6.1 The following shall amount to breach of contract:

- I. Non-supply of material/ non-completion of work by the Supplier/Vendor within scheduled delivery/ completion period as per contract or as extended from time to time.
- II. The Supplier/Vendor fails to perform as per the activity schedule and there are sufficient reasons even before expiry of the delivery/ completion period to justify that supplies shall be inordinately delayed beyond contractual delivery/ completion period.
- III. The Supplier/Vendor delivers equipment/ material not of the contracted quality.
- IV. The Supplier/Vendor fails to replace the defective equipment/ material/ component as per guarantee clause.
- V. Withdrawal from or abandonment of the work by the Supplier/Vendor before completion as per contract.
- VI. Assignment, transfer, subletting of Contract by the Supplier/Vendor without BHEL's written permission resulting in termination of Contract or part thereof by BHEL.
- VII. Non-compliance to any contractual condition or any other default attributable to Supplier/Vendor.
- VIII. Any other reason(s) attributable to Vendor towards failure of performance of contract. In case of breach of contract, BHEL shall have the right to terminate the Purchase Order/ Contract either in whole or in part thereof without any compensation to the Supplier/Vendor.
- IX. Any of the declarations furnished by the contractor at the time of bidding and/ or entering into the contract for supply are found untruthful and such declarations were of a nature that could have resulted in non-award of contract to the contractor or could expose BHEL and/ or Owner to adverse consequences, financial or otherwise.
- X. Supplier/Vendor is convicted of any offence involving corrupt business practices, antinational activities or any such offence that compromises the business ethics of BHEL, in violation of the Integrity Pact entered into with BHEL has the potential to harm the overall business of BHEL/ Owner.

Note-Once BHEL considers that a breach of contract has occurred on the part of Supplier/Vendor, BHEL shall notify the Supplier/Vendor by way of notice in this regard. Contractor shall be given an opportunity to rectify the reasons causing the breach of contract within a period of 14 days.

In case the contractor fails to remedy the breach, as mentioned in the notice, to the satisfaction of BHEL, BHEL shall have the right to take recourse to any of the remedial actions available to it under the relevant provisions of contract.

Place:
Date:

Signature of Authorized Signatory
with seal & full address



Bharat Heavy Electricals Limited

(A Govt. of India Undertaking)

Power Plant Piping Unit, Thirumayam – 622 507, Tamil Nadu

Tender Notice

6.2 Remedies in case of Breach of Contract.

- i. Wherein the period as stipulated in the notice issued under clause 14.1 has expired and Supplier/Vendor has failed to remedy the breach, BHEL will have the right to terminate the contract on the ground of "Breach of Contract" without any further notice to contractor.
- ii. Upon termination of contract, BHEL shall be entitled to recover an amount equivalent to 10% of the Contract Value for the damages on account of breach of contract committed by the Supplier/Vendor. This amount shall be recovered by way of encashing the security instruments like performance bank guarantee etc available with BHEL against the said contract. In case the value of the security instruments available is less than 10% of the contract value, the balance amount shall be recovered from other financial remedies (i.e. available bills of the Supplier/Vendor, retention amount, from the money due to the Supplier/Vendor etc. with BHEL) or the other legal remedies shall be pursued.
- iii. wherever the value of security instruments like performance bank guarantee available with BHEL against the said contract is 10% of the contract value or more, such security instruments to the extent of 10% contract value will be encashed. In case no security instruments are available or the value of the security instruments available is less than 10% of the contract value, the 10% of the contract value or the balance amount, as the case may be, will be recovered in all or any of the following manners:
- iv. In case the amount recovered under sub clause (a) above is not sufficient to fulfil the amount recoverable then; a demand notice to deposit the balance amount within 30 days shall be issued to Supplier/Vendor.
- v. If Supplier/Vendor fails to deposit the balance amount within the period as prescribed in demand notice, following action shall be taken for recovery of the balance amount:
 - a) from dues available in the form of Bills payable to defaulted Supplier/Vendor against the same contract.
 - b) If it is not possible to recover the dues available from the same contract or dues are insufficient to meet the recoverable amount, balance amount shall be recovered from any money(s) payable to Supplier/Vendor under any contract with other Units of BHEL including recovery from security deposits or any other deposit available in the form of security instruments of any kind against Security deposit or EMD.
- vi. In-case recoveries are not possible with any of the above available options, Legal action shall be initiated for recovery against defaulted supplier/Vendor.
- vii. It is an agreed term of contract that this amount shall be a genuine pre-estimate of damages that BHEL would incur in completion of balance contractual obligation of the contract through any other agency and BHEL will not be required to furnish any other evidence to the Supplier/Vendor for the purpose of estimation of damages.
- viii. In addition to the above, imposition of liquidated damages, debarment, termination, de-scoping, short-closure, etc., shall be applied as per provisions of the contract.

Place:
Date:

Signature of Authorized Signatory
with seal & full address



Bharat Heavy Electricals Limited

(A Govt. of India Undertaking)

Power Plant Piping Unit, Thirumayam – 622 507, Tamil Nadu

Tender Notice

Note:

- 1) The defaulting Supplier/Vendor shall not be eligible for participation in any of the future enquiries floated by BHEL to complete the balance work. The defaulting contractor shall mean and include:
 - (a) In case defaulted Supplier/Vendor is the Sole Proprietorship Firm, any Sole Proprietorship Firm owned by same Sole Proprietor.
 - (b) In case defaulted Supplier/Vendor is The Partnership Firm, any firm comprising of same partners/ some of the same partners; or sole proprietorship firm owned by any partner(s) as a sole proprietor.

7 MICRO AND SMALL ENTERPRISES (MSE):

Any Bidder falling under MSE category shall furnish the following details & submit documentary evidence/ Govt. Certificate etc. in support of the same along with their techno-commercial offer.

Type under MSE	SC/ST owned	Women owned	Others(excluding SC/DT & Women Owned)
Micro			
Small			

Note: If the bidder does not furnish the above, offer shall be processed construing that the bidder is not falling under MSE category.

- a) MSE suppliers can avail the intended benefits in respect of the procurements related to the Goods and Services only (Definition of Goods and Services as enumerated by Govt. of India vide Office Memorandum F. No. 21(8)/2011-MA dtd. 09/11/2016 office of AS & DC, MSME) only if they submit along with the offer, attested copies of either Udyam Registration. Date to be reckoned for determining the deemed validity will be the last date of Technical Bid submission. Non-submission of supporting document in GeM portal will lead to consideration of their bids at par with other bidders. No benefits shall be applicable for this enquiry if the above required documents are not uploaded at the time of bid submission. Documents submitted by the bidder shall be verified by BHEL for rendering the applicable benefits.
- b) If MSEs quoted price is within price band L-1 + 15%, when L1 is non- MSE, the MSEs will be allowed to supply at least 25% of tendered quantity at L-1 rate subject to acceptance by MSEs to L-1 rate. (Minimum of 3% reservation for women owned MSEs and 6.25% for MSEs owned by SC/ST within the above mentioned 25% reservation). In case the contract cannot be split, the full/ complete supply of total tendered value shall be awarded to MSE at L-1 rate subject to acceptance by MSEs to L-1 rate. The preference to the MSEs will be given in order of their ranking L1, L2, L3, etc.

Place:
Date:

Signature of Authorized Signatory
with seal & full address



Bharat Heavy Electricals Limited

(A Govt. of India Undertaking)

Power Plant Piping Unit, Thirumayam – 622 507, Tamil Nadu

Tender Notice

8 LIQUIDATED DAMAGE:

Liquidated Damages, wherever referred under this Tender/Agreement, shall mean and refer to the damages, not in the nature of penalty, which the contractor agrees to pay in the event of delay in delivery of supplies, breach of contract etc. as the case may be.

Liquidated Damages leviable upon the Supplier/Vendor is a sum which is agreed by the parties as a reasonable and genuine pre-estimate of damages which will be suffered by BHEL on account of delay/breach on the part of the Supplier/Vendor.

If the Seller/Service Provider fails to deliver any or all of the Goods/Services within the original/re-fixed delivery period(s) specified in the contract/PO, the Buyer/BHEL will be entitled to deduct/recover the Liquidated Damages for the delay, unless covered under Force Majeure conditions aforesaid, @ 0.5% of the contract value of delayed quantity per week or part of the week of delayed period as pre-estimated damages not exceeding 10% of the contract value of delayed quantity without any controversy/dispute of any sort whatsoever.

9 PREFERENCE TO MAKE IN INDIA:

For this procurement, the local content to categorize a Supplier/Vendor as a Class I local supplier/ Class II local Supplier/Non-Local Supplier and purchase preferences to Class I local supplier, is as defined in Public Procurement (Preference to Make in India), Order 2017 dated 04.06.2020 issued by DPIIT. In case of subsequent orders issued by the nodal ministry, changing the definition of local content for the items of the GeM Bid, the same shall be applicable even if issued after issue of this GeM Bid, but before opening of Part-II bids against this GeM Bid.

9.1 Compliance to Restrictions under Rule 144 (xi) of GFR 2017:

- I. Any bidder from a country which shares a land border with India will be eligible to bid in this tender only if the bidder is registered with the Competent Authority. The Competent Authority for the purpose of this Clause shall be the Registration Committee constituted by the Department for Promotion of Industry and Internal Trade (DPIIT).
- II. "Bidder" (including the term 'tenderer', 'consultant' or 'service provider' in certain contexts) means any person or firm or company, including any member of a consortium or joint venture (that is an association of several persons, or firms or companies), every artificial juridical person not falling in any of the descriptions of bidders stated hereinbefore, including any agency branch or office controlled by such person, participating in a procurement process.
- III. "Bidder from a country which shares a land border with India" for the purpose of this Clause means: -
 - a. An entity incorporated established or registered in such a country; or
 - b. A subsidiary of an entity incorporated established or registered in such a country; or
 - c. An entity substantially controlled through entities incorporated, established or registered in such a country; or

Place:
Date:

Signature of Authorized Signatory
with seal & full address



Bharat Heavy Electricals Limited

(A Govt. of India Undertaking)

Power Plant Piping Unit, Thirumayam – 622 507, Tamil Nadu

Tender Notice

- d. An entity whose beneficial owner is situated in such a country; or
- e. An Indian (or other) agent of such an entity; or
- f. A natural person who is a citizen of such a country; or
- g. A consortium or joint venture where any member of the consortium or joint venture falls under any of the above.

IV. The beneficial owner for the purpose of (III) above will be as under:

1. In case of a company or Limited Liability Partnership, the beneficial owner is the natural person(s), who, whether acting alone or together or through one or more juridical person, has a controlling ownership interest or who exercises control through other means.

Explanation

- a. "Controlling ownership interest" means ownership of or entitlement to more than twenty-five per cent of shares or capital or profits of the company.
 - b. "Control" shall include the right to appoint majority of the directors or to control the management or policy decisions including by virtue of their shareholding or management rights or shareholders' agreements or voting agreements.
2. In case of a partnership firm, the beneficial owner is the natural person(s) who, whether acting alone or together, or through one or more juridical person, has ownership of entitlement to more than fifteen percent of capital or profits of the partnership.
 3. In case of an unincorporated association or body of individuals, the beneficial owner is the natural person(s), who, whether acting alone or together, or through one or more juridical person has ownership of or entitlement to more than fifteen percent of the property or capital or profits of the such association or body of individuals.
 4. Where no natural person is identified under (1) or (2) or (3) above, the beneficial owner is the relevant natural person who holds the position of senior managing official;
 5. In case of a trust, the identification of beneficial owner(s) shall include identification of the author of the trust, the trustee, the beneficiaries with fifteen percent or more interest in the trust and any other natural person exercising ultimate effective control over the trust through a chain of control or ownership.

V. An Agent is a person employed to do any act for another, or to represent another in dealings with third person.

Note:

- i. The bidder shall provide undertaking for their compliance to this Clause, in the format provided in Annexure-13. *(Green Highlight is done as per the model document)*
- ii. Registration of the bidder with Competent Authority should be valid at the time of submission of bids and at the time of acceptance of the bids.

10 Settlement of Dispute

If any dispute or difference of any kind whatsoever shall arise between BHEL and the Supplier/Vendor, arising out of the contract for the performance of the work whether during the progress of contract

Place:

Date:

Signature of Authorized Signatory
with seal & full address



Bharat Heavy Electricals Limited

(A Govt. of India Undertaking)

Power Plant Piping Unit, Thirumayam – 622 507, Tamil Nadu

Tender Notice

termination, abandonment or breach of the contract, it shall in the first place referred to Designated Engineer for amicable resolution by the parties. Designated Engineer (to be nominated by BHEL for settlement of disputes arising out of the contract) who within 60 days after being requested shall give written notice of his decision to the contractor. Save as hereinafter provided, such decision in respect of every matter so referred shall forthwith be given effect to by the Supplier/Vendor who shall proceed with the work with all due diligence, whether he or BHEL desires to resolve the dispute as hereinafter provided or not.

If after the Designated Engineer has given written notice of this decision to the party and no intention to pursue the dispute has been communicated to him by the affected party within 30 days from the receipt of such notice, the said decision shall become final and binding on the parties. In the event the Supplier/Vendor being dissatisfied with any such decision or if amicable settlement cannot be reached then all such disputed issues shall be resolved through conciliation in terms of the BHEL Conciliation Scheme 2018 as per Clause 21.1

10.1 Conciliation:

Any dispute, difference or controversy of whatever nature howsoever arising under or out of or in relation to this Agreement (including its interpretation) between the Parties, and so notified in writing by either Party to the other Party (the "Dispute") shall, in the first instance, be attempted to be resolved amicably in accordance with the conciliation procedure as per BHEL Conciliation Scheme 2018. The proceedings of Conciliation shall broadly be governed by Part-III of the Arbitration and Conciliation Act 1996 or any statutory modification thereof and as provided in - "Procedure for conduct of conciliation proceedings" (as available in www.bhel.com)).

Note: Ministry of Finance has issued OM reference No. 1/2/24 dated 03.06.2024 regarding "Guidelines for Arbitration and Mediation in Contracts of Domestic Public Procurement. In the said OM it has been recommended that Government departments/

Entities/agencies are to encourage mediation under the Mediation Act. 2023. The said Act has not yet been notified by the Government. Therefore, the clause "Settlement of Disputes" shall be modified accordingly as and when the Mediation Act 2023 gets notified.

10.2 ARBITRATION:

10.2.5 Except as provided elsewhere in this Contract, in case Parties are unable to reach amicable settlement (whether by Conciliation to be conducted as provided in Clause 14.1 herein above or otherwise) in respect of any dispute or difference; arising out of the formation, breach, termination, validity or execution of the Contract; or, the respective rights and liabilities of the Parties; or, in relation to interpretation of any provision of the Contract; or, in any manner touching upon the Contract (hereinafter referred to as the 'Dispute'), then, either Party may, refer the disputes to **Madras High Court, Arbitration Centre (MHCAC)** and such dispute to be adjudicated by Sole Arbitrator appointed in accordance with the Rules of said Arbitral Institution.

Place:
Date:

Signature of Authorized Signatory
with seal & full address



Bharat Heavy Electricals Limited

(A Govt. of India Undertaking)

Power Plant Piping Unit, Thirumayam – 622 507, Tamil Nadu

Tender Notice

- 10.2.6 A party willing to commence arbitration proceeding shall invoke Arbitration Clause by giving notice to the other party in terms of section 21 of the Arbitration & Conciliation Act, 1996 (hereinafter referred to as the 'Notice') before referring the matter to arbitral institution. The Notice shall be addressed to the Head of the Unit, BHEL, executing the Contract and shall contain the particulars of all claims to be referred to arbitration with sufficient detail and shall also indicate the monetary amount of such claim including interest, if any.
- 10.2.7 After expiry of 30 days from the date of receipt of aforesaid notice, the party invoking the Arbitration shall submit that dispute to the Arbitral Institution- **Madras High Court, Arbitration Centre (MHCAC)**- and that dispute shall be adjudicated in accordance with their respective Arbitration Rules. The matter shall be adjudicated by a Sole Arbitrator who shall necessarily be a Retd Judge having considerable experience in commercial matters to be appointed/nominated by the respective institution. The cost/expenses pertaining to the said Arbitration shall also be governed in accordance with the Rules of the respective Arbitral Institution. The decision of the party invoking the Arbitration for reference of dispute to **Madras High Court, Arbitration Centre (MHCAC)**- for adjudication of that dispute shall be final and binding on both the parties and shall not be subject to any change thereafter. The institution once selected at the time of invocation of dispute shall remain unchanged.
- 10.2.8 The fee and expenses shall be borne by the parties as per the Arbitral Institutional rules.
- 10.2.9 The Arbitration proceedings shall be in English language and the seat of Arbitration shall be **Trichy**.
- 10.2.10 Subject to the above, the provisions of Arbitration & Conciliation Act 1996 and any amendment thereof shall be applicable. All matters relating to this Contract and arising out of invocation of Arbitration clause are subject to the exclusive jurisdiction of the Court(s) situated at **Trichy**.
- 10.2.11 Notwithstanding any reference to the Designated Engineer or Conciliation or Arbitration herein, a. the parties shall continue to perform their respective obligations under the Contract unless they otherwise agree. Settlement of Dispute clause cannot be invoked by the Contractor, if the Contract has been mutually closed or 'No Demand Certificate' has been furnished by the Contractor or any Settlement Agreement has been signed between the Employer and the Contractor.
- 10.2.12 It is agreed that Mechanism of resolution of disputes through arbitration shall be available only in the cases where the value of the dispute is less than Rs. 10 Crores.
- 10.2.13 In case the disputed amount Claim, Counter claim including interest is Rs. 10 crores and above, the parties shall be within their rights to take recourse to remedies other than Arbitration, as may be available to them under the applicable laws after prior intimation to the other party. Subject to the aforesaid conditions, provisions of the Arbitration and

Place:
Date:

Signature of Authorized Signatory
with seal & full address



Bharat Heavy Electricals Limited

(A Govt. of India Undertaking)

Power Plant Piping Unit, Thirumayam – 622 507, Tamil Nadu

Tender Notice

Conciliation Act, 1996 and any statutory modifications or re-enactment thereof as amended from time to time, shall apply to the arbitration proceedings under this clause.

10.2.14 In case, multiple arbitrations are invoked (whether sub-judice or arbitral award passed) by any party to under this contract, then the cumulative value of claims (including interest claimed or awarded) in all such arbitrations shall be taken in account while arriving at the total claim in dispute for the subject contract for the purpose of clause 14.2.9. Disputes having cumulative value of less than 10 crores shall be resolved through arbitration and any additional dispute shall be adjudicated by the court of competent jurisdiction.

10.2.15 In case of Contract with Public Sector Enterprise (PSE) or a Government Department, the following shall be applicable:

In the event of any dispute or difference relating to the interpretation and application of the provisions of commercial contract(s) between Central Public Sector Enterprises (CPSEs)/ Port Trusts inter se and also between CPSEs and Government Departments/Organizations (excluding disputes concerning Railways, Income Tax, Customs & Excise Departments), such dispute or difference shall be taken up by either party for resolution through AMRCD (Administrative Mechanism for Resolution of CPSEs Disputes) as mentioned in DPE OM No. 05/0003/2019-FTS-10937 dated 14-12-2022 as amended from time to time.

11 Force Majeure

11.1 "Force Majeure" shall mean circumstance which is:

- beyond control of either of the parties to contract,
- either of the parties could not reasonably have provided against the event before entering into the contract,
- having arisen, either of the parties could not reasonably have avoided or overcome, and
- is not substantially attributable to either of the parties

And

Prevents the performance of the contract,

Such circumstances include but shall not be limited to:

- War, hostilities, invasion, act of foreign enemies.
- Rebellion, terrorism, revolution, insurrection, military or usurped power, or civil war.
- Riot, commotion or disorder by persons other than the contractor's personnel and other employees of the contractor and sub-contractors.
- Strike or lockout not solely involving the contractor's personnel and other employees of the contractor and sub-contractors.
- Encountering munitions of war, explosive materials, ionizing radiation or contamination by radio-activity, except as may be attributable to the contractor's use of such munitions, explosives, radiation or radio- activity.
- Natural catastrophes such as earthquake, tsunami, volcanic activity, hurricane or typhoon, flood, fire, cyclones etc.

Place:
Date:

Signature of Authorized Signatory
with seal & full address



Bharat Heavy Electricals Limited

(A Govt. of India Undertaking)

Power Plant Piping Unit, Thirumayam – 622 507, Tamil Nadu

Tender Notice

vii. Epidemic, pandemic etc.

11.2 The following events are explicitly excluded from Force Majeure and are solely the responsibilities of the non-performing party: a) any strike, work-to-rule action, go-slow or similar labour difficulty (b) late delivery of equipment or material (unless caused by Force Majeure event) and (c) economic hardship.

11.3 If either party is prevented, hindered or delayed from or in performing any of its obligations under the Contract by an event of Force Majeure, then it shall notify the other in writing of the occurrence of such event and the circumstances thereof within 15 (fifteen) days after the occurrence of such event.

11.4 The party who has given such notice shall be excused from the performance or punctual performance of its obligations under the Contract for so long as the relevant event of Force Majeure continues and to the extent that such party's performance is prevented, hindered or delayed. The Time for Completion shall be extended by a period of time equal to period of delay caused due to such Force Majeure event.

11.5 Delay or non-performance by either party hereto caused by the occurrence of any event of Force Majeure shall not

- i. Constitute a default or breach of the Contract.
- ii. Give rise to any claim for damages or additional cost expense occasioned thereby, if and to the extent that such delay or non-performance is caused by the occurrence of an event of Force Majeure.

11.6 BHEL at its discretion may consider short closure of contract after 1 year of imposition of Force Majeure in line with extant guidelines. In any case, Supplier/Vendor cannot consider deemed short-closure after 1 year of imposition of Force Majeure.

12 Cartel Formation

The Bidder declares that they will not enter into any illegal or undisclosed agreement or understanding, whether formal or informal with other Bidder(s). This applies in particular to prices, specifications, certifications, subsidiary contracts, submission or non-submission of bids or any other actions to restrict competitiveness or to introduce cartelization in the bidding process. In case, the Bidder is found having indulged in above activities, suitable action shall be taken by BHEL as per extant policies/ guidelines.

13 Fraud Prevention Policy

Bidder along with its associate /collaborators /sub-contractors /sub-vendors / consultants / service providers shall strictly adhere to BHEL Fraud Prevention Policy displayed on BHEL website <http://www.bhel.com> and shall immediately bring to the notice of BHEL Management about any fraud or suspected fraud as soon as it comes to their notice.

14 Suspension of Business Dealings with Suppliers / Contractors:

Place:
Date:

Signature of Authorized Signatory
with seal & full address



Bharat Heavy Electricals Limited

(A Govt. of India Undertaking)

Power Plant Piping Unit, Thirumayam – 622 507, Tamil Nadu

Tender Notice

The offers of the bidders who are under suspension as also the offers of the bidders, who engage the services of the banned firms / principal / agents, shall be rejected. The list of banned firms is available on BHEL web site www.bhel.com.

If any bidder / supplier / contractor during pre-tendering / tendering / post tendering / award / execution / post-execution stage indulges in any act, including but not limited to, mal-practices, cheating, bribery, fraud or and other misconduct or formation of cartel so as to influence the bidding process or influence the price or tampers the tendering process or acts or omits in any manner which tantamount to an offence punishable under any provision of the Indian Penal Code, 1860(Bhartiya Nyaya Samhita 2023) or any other law in force in India, or does anything which is actionable under the Guidelines for Suspension of Business dealings, action may be taken against such bidder / supplier / contractor as per extant guidelines of the company available on www.bhel.com and / or under applicable legal provisions. Guidelines for suspension of business dealings is available in the webpage: http://www.bhel.com/vender_registration/vender.php.

15 Order of Precedence:

In the event of any ambiguity or conflict between the Tender Documents, the order of precedence shall be in the order below:

- a. Amendments/Clarifications/Corrigenda/Errata etc. issued in respect of the tender documents by BHEL.
- b. GeM Bid
- c. Buyer Added Bid Specific ATC
- d. BHEL General Conditions of Contract (GCC)
- e. GeM Bid Technical Conditions of Contract (TCC)
- f. GeM GTC

16 Enclosure:

Annexure-1: Check List.

Annexure-2: Offer forwarding letter / tender submission letter

Annexure-3: No Deviation Certificate

Annexure-4: Declaration regarding Insolvency/ Liquidation/ Bankruptcy Proceedings

Annexure-5: Declaration by Authorized Signatory

Annexure-6: Declaration by Authorized Signatory regarding Authenticity of submitted Documents

Annexure-7: Non-Disclosure Certificate

Annexure-8: Integrity Pact (Not applicable)

Annexure-9: Declaration confirming knowledge about Site Conditions (*Not Applicable*)

Annexure-10: Declaration reg. Related Firms & their areas of Activities

Annexure-11: Declaration for relation in BHEL

Annexure- 12: Declaration reg. minimum local content in line with revised public procurement

Annexure- 13: Declaration regarding compliance to Restrictions under Rule 144 (xi) of GFR 2017

Annexure-14: Bank Account Details for E-Payment

Place:

Date:

Signature of Authorized Signatory
with seal & full address



Bharat Heavy Electricals Limited

(A Govt. of India Undertaking)

Power Plant Piping Unit, Thirumayam – 622 507, Tamil Nadu

Tender Notice

Annexure-15: Power of Attorney for submission of tender.

Annexure-16: Proforma of Bank Guarantee for Earnest Money.

Annexure-17: Proforma of Bank Guarantee for Performance Security.

Annexure-18: List of Consortium Bank.

Annexure-19: E-Payments

Annexure-20: Format of Letter Confirming the Lien on Fixed Deposit Receipt

Annexure-21: Format for filling General Details

Place:
Date:

Signature of Authorized Signatory
with seal & full address



Bharat Heavy Electricals Limited

(A Govt. of India Undertaking)

Power Plant Piping Unit, Thirumayam – 622 507, Tamil Nadu

Tender Notice

ANNEXURE- 1

CHECK LIST

NOTE: - Suppliers are required to fill in the following details in their Letterhead and no column should be left blank

A	Name and Address of the Supplier		
B	GSTN No. the Supplier (Place of Execution of Contract / Purchase Order)		
C	Details of Contact person for this Tender	Name: Mr./ Ms. Designation: Telephone No: Mobile No: Email ID:	
D	EMD DETAILS		
E	DESCRIPTION	APPLICABILITY (BY BHEL)	ENCLOSED BY BIDDER
i.	Whether Pre - Qualification Criteria is understood and provided proper supporting documents.	Applicable/ Not Applicable	YES / NO
ii.	Whether all pages of the Tender documents including annexures, appendices etc are read and understood	Applicable/ Not Applicable	YES / NO
iii.	Audited Balance Sheet and profit & Loss Account for the last three years	Applicable/ Not Applicable	YES / NO
iv.	Copy of PAN Card & GST registration [Authorized signatory attested copy shall be submitted]	Applicable/ Not Applicable	YES / NO
v.	Submission of MSE certificate (UDYAM certificate) as specified in Tender [Authorized signatory attested copy shall be submitted]	Applicable/ Not Applicable	YES / NO
vi.	Offer forwarding letter / tender submission letter as per Annexure – 2	Applicable/ Not Applicable	YES / NO
vii.	Submission of Certificate of No Deviation as per Annexure – 3	Applicable/ Not Applicable	YES / NO

Place:
Date:

Signature of Authorized Signatory
with seal & full address



Bharat Heavy Electricals Limited

(A Govt. of India Undertaking)

Power Plant Piping Unit, Thirumayam – 622 507, Tamil Nadu

Tender Notice

viii.	Declaration regarding Insolvency/ Liquidation/ Bankruptcy Proceedings as per Annexure – 4	Applicable/ Not Applicable	YES / NO
ix.	Declaration by Authorized Signatory as per Annexure – 5	Applicable/ Not Applicable	YES / NO
x.	Declaration by Authorized Signatory regarding Authenticity of submitted Documents Annexure – 6	Applicable/ Not Applicable	YES / NO
xi.	Submission of Non-Disclosure Certificate as per Annexure – 7	Applicable/ Not Applicable	YES / NO
xii.	Submission of Integrity Pact as specified in Tender as per Annexure – 8	Applicable/ Not Applicable	YES / NO
xiii.	Declaration confirming knowledge about Site Conditions as per Annexure – 9	Applicable/ Not Applicable	YES / NO
xiv.	Declaration reg. Related Firms & their areas of Activities as per Annexure – 10	Applicable/ Not Applicable	YES / NO
xv.	Declaration for relation in BHEL as per Annexure – 11	Applicable/ Not Applicable	YES / NO
xvi.	Declaration reg. minimum local content in line with revised public procurement as per Annexure – 12	Applicable/ Not Applicable	YES / NO
xvii.	Declaration regarding compliance to Restrictions under Rule 144 (xi) of GFR 2017 as per Annexure – 13	Applicable/ Not Applicable	YES / NO
xviii.	Bank Account Details for E-Payment as per Annexure – 14	Applicable/ Not Applicable	YES / NO
xix.	Power of Attorney for submission of tender as per Annexure – 15	Applicable/ Not Applicable	YES / NO
xx.	Proforma of Bank Guarantee for Earnest Money as per Annexure – 16	Applicable/ Not Applicable	YES / NO
xxi.	Submission of General Details as per Annexure-21	Applicable/ Not Applicable	YES / NO

NOTE: Strike off 'YES' or 'NO', as applicable. Tender not accompanied by the prescribed **above applicable documents** are liable to be summarily rejected.

DATE:

**Sign. of the AUTHORISED SIGNATORY
(With Name, Designation and Company seal)**

Place:
Date:

Signature of Authorized Signatory
with seal & full address



Bharat Heavy Electricals Limited

(A Govt. of India Undertaking)

Power Plant Piping Unit, Thirumayam – 622 507, Tamil Nadu

Tender Notice

ANNEXURE - 2

OFFER FORWARDING LETTER / TENDER SUBMISSION LETTER

(To be typed and submitted in the Letter Head of the Company/Firm of Bidder)

Offer Reference No:

Date:

To,

(Write Name & Address of Officer of BHEL inviting the Tender)

Dear Sir,

Sub: Submission of Offer against GeM Bid No:

Having examined the tender documents against your GeM Bid No. _____ dated _____ and having understood the provisions of the said tender documents and having thoroughly studied the requirements of BHEL related to the work tendered for, in connection with _____ (name of work & project site), we hereby submit our offer for the proposed work in accordance with terms and conditions mentioned in the tender documents, at the prices quoted by us and as per the indicated delivery schedule.

Should our Offer be accepted by BHEL for Award, I/we further agree to furnish 'Performance Security' for the work as provided for in the Tender Conditions within the stipulated time as may be indicated by BHEL.

I/We further agree to execute all the works referred to in the said Tender documents upon the terms and conditions contained or referred to therein and as detailed in the appendices annexed thereto.

I/We have deposited herewith the requisite Earnest Money Deposit (EMD) as per details furnished in the Check List.

Authorised Representative of Bidder

Signature:

Name:

Address:

Place:

Date:

Signature of Authorized Signatory
with seal & full address



Bharat Heavy Electricals Limited

(A Govt. of India Undertaking)

Power Plant Piping Unit, Thirumayam – 622 507, Tamil Nadu

Tender Notice

Place:

Date:

ANNEXURE- 3

CERTIFICATE OF NO DEVIATION

(To be Typed & submitted in the Letter Head of the Company/Firm of Bidder)

To,

(Write Name & Address of Officer of BHEL inviting the Tender)

Dear Sir,

Subject: No Deviation Certificate

Ref: 1) GeM Bid No:
2) All other pertinent issues till date

We hereby confirm that we have not changed/ modified/materially altered any of the tender documents as downloaded from the website/ issued by BHEL and in case of such observance at any stage, it shall be treated as null and void.

We also hereby confirm that we have neither set any Terms and Conditions and nor have we taken any deviation from the Tender conditions together with other references applicable for the above referred GeM Bid.

We further confirm our unqualified acceptance to all Terms and Conditions, unqualified compliance to Tender Conditions.

We confirm to have submitted offer in accordance with tender instructions and as per aforesaid references.

Thanking you,

Yours faithfully,

Date:

Sign. of the AUTHORISED SIGNATORY

Place:

Signature of Authorized Signatory
with seal & full address

Date:



Bharat Heavy Electricals Limited

(A Govt. of India Undertaking)

Power Plant Piping Unit, Thirumayam – 622 507, Tamil Nadu

Tender Notice

Place:

(With Name, Designation and Company seal)

ANNEXURE- 4

UNDERTAKING

(To be typed and submitted in the Letter Head of the Company/Firm of Bidder)

To,

(Write Name & Address of Officer of BHEL inviting the Tender)

Dear Sir/Madam,

Sub: DECLARATION REGARDING INSOLVENCY/ LIQUIDATION/ BANKRUPTCY PROCEEDINGS

Ref: GeM Bid Specification No:

I/We,

declare that, I/We am/are not admitted under insolvency resolution process or liquidation under Insolvency and Bankruptcy Code, 2016, as amended from time to time or under any other law as on date, by NCLT or any adjudicating authority/authorities.

Place:

Date:

Sign. of the AUTHORISED SIGNATORY
(With Name, Designation and Company seal)

Place:

Date:

Signature of Authorized Signatory
with seal & full address



Bharat Heavy Electricals Limited

(A Govt. of India Undertaking)

Power Plant Piping Unit, Thirumayam – 622 507, Tamil Nadu

Tender Notice

ANNEXURE – 5

DECLARATION BY AUTHORISED SIGNATORY OF BIDDER

(To be typed and submitted in the Letter Head of the Company/Firm of Bidder)

To,

(Write Name & Address of Officer of BHEL inviting the Tender)

Dear Sir,

Sub: **Declaration by Authorised Signatory**

Ref: 1) GeM Bid Specification No:

2) All other pertinent issues till date

I/We, hereby certify that all the information and data furnished by me with regard to the above Tender Specification are true and complete to the best of my knowledge. I have gone through the specifications, conditions, stipulations and all other pertinent issues till date, and agree to comply with the requirements and Intent of the specification.

I further certify that I am authorised to represent on behalf of my Company/Firm for the above mentioned tender and a valid Power of Attorney to this effect is also enclosed.

Yours faithfully,

(Signature, Date & Seal of Authorized
Signatory of the Bidder)

Date:

Enclosed: Power of Attorney

Place:

Date:

Signature of Authorized Signatory
with seal & full address



Bharat Heavy Electricals Limited

(A Govt. of India Undertaking)

Power Plant Piping Unit, Thirumayam – 622 507, Tamil Nadu

Tender Notice

ANNEXURE – 6

DECLARATION BY AUTHORISED SIGNATORY OF BIDDER

(To be typed and submitted in the Letter Head of the Company/Firm of Bidder)

To,

(Write Name & Address of Officer of BHEL inviting the Tender)

Dear Sir,

Sub: **Declaration by Authorised Signatory regarding Authenticity of submitted documents.**

Ref: 1) GeM Bid No. & Date:

2) All other pertinent issues till date

I/We, hereby certify that all the documents submitted by us in support of possession of “Qualifying Requirements” are true copies of the original and are fully compliant required for qualifying / applying in the bid and shall produce the original of same as and when required by Bharat Heavy Electricals Limited.

I / We hereby further confirm that no tampering is done with documents submitted in support of our qualification as bidder. I / We understand that at any stage (during bidding process or while executing the awarded contract) if it is found that fake / false / forged bid qualifying / supporting documents / certificates were submitted, it would lead to summarily rejection of our bid / termination of contract. BHEL shall be at liberty to initiate other appropriate actions as per the terms of the Bid / Contract and other extant policies of Bharat Heavy Electricals Limited.

Yours faithfully,

(Signature, Date & Seal of Authorized Signatory of the Bidder)

Date:

Signature of Authorized Signatory
with seal & full address

Place:
Date:



Tender Notice

ANNEXURE- 7

NON-DISCLOSURE CERTIFICATE

(To be Typed & submitted in the Letter Head of the Company/Firm of Bidder)

I/We understand that BHEL Thirumayam is committed to Information Security Management System as per their Information Security Policy.

Hence, I/We M/s

.....
who are submitting offer for providing services to BHEL Thirumayam against GeM Bid No..... hereby undertake to comply with the following in line with Information Security Policy of < BHEL Thirumayam

- To maintain confidentiality of documents & information which shall be used during the execution of the Contract.

- The documents & information shall not be revealed to or shared with third party which shall not be in the business interest of BHEL Thirumayam

(Signature, date & seal of Authorized Signatory of the bidder)

Date:

Signature of Authorized Signatory
with seal & full address

Place:
Date:



Bharat Heavy Electricals Limited

(A Govt. of India Undertaking)

Power Plant Piping Unit, Thirumayam – 622 507, Tamil Nadu

Tender Notice

ANNEXURE – 8 (Not applicable)

INTEGRITY PACT

Between

Bharat Heavy Electricals Ltd. (BHEL), a company registered under the Companies Act 1956 and having its registered office at "BHEL House", Siri Fort, New Delhi - 110049 (India) hereinafter referred to as "The Principal", which expression unless repugnant to the context or meaning hereof shall include its successors or assigns of the ONE PART

and

_____, (description of the party along with address), hereinafter referred to as "The Bidder/ Contractor" which expression unless repugnant to the context or meaning hereof shall include its successors or assigns of the OTHER PART

Preamble

The Principal intends to award, under laid-down organizational procedures, contract/s for

_____. The Principal values full compliance with all relevant laws of the land, rules and regulations, and the principles of economic use of resources, and of fairness and transparency in its relations with its Bidder(s)/ Contractor(s).

In order to achieve these goals, the Principal will appoint Independent External Monitor(s), who will monitor the tender process and the execution of the contract for compliance with the principles mentioned above.

Section 1- Commitments of the Principal

1.1 The Principal commits itself to take all measures necessary to prevent corruption and to observe the following principles: -

1.1.1 No employee of the Principal, personally or through family members, will in connection with the tender for, or the execution of a contract, demand, take a promise for or accept, for self or third person, any material or immaterial benefit which the person is not legally entitled to.

1.1.2 The Principal will, during the tender process treat all Bidder(s) with equity and reason. The Principal will in particular, before and during the tender process, provide to all Bidder(s) the same information and will not provide to any Bidder(s) confidential/ additional information

Place:
Date:

Signature of Authorized Signatory
with seal & full address



Bharat Heavy Electricals Limited

(A Govt. of India Undertaking)

Power Plant Piping Unit, Thirumayam – 622 507, Tamil Nadu

Tender Notice

through which the Bidder(s) could obtain an advantage in relation to the tender process or the contract execution.

1.1.3 The Principal will exclude from the process all known prejudiced persons.

1.2 If the Principal obtains information on the conduct of any of its employees which is a penal offence under the Indian Penal Code 1860 and Prevention of Corruption Act 1988 or any other statutory penal enactment, or if there be a substantive suspicion in this regard, the Principal will inform its Vigilance Office and in addition can initiate disciplinary actions.

Section 2 - Commitments of the Bidder(s)/ Contractor(s)

2.2 The Bidder(s)/ Contractor(s) commit himself to take all measures necessary to prevent corruption. He commits himself to observe the following principles during his participation in the tender process and during the contract execution.

2.1.1 The Bidder(s)/ Contractor(s) will not, directly or through any other person or firm, offer, promise or give to the Principal or to any of the Principal's employees involved in the tender process or the execution of the contract or to any third person any material, immaterial or any other benefit which he/ she is not legally entitled to, in order to obtain in exchange any advantage of any kind whatsoever during the tender process or during the execution of the contract.

2.1.2 The Bidder(s)/ Contractor(s) will not enter with other Bidder(s) into any illegal or undisclosed agreement or understanding, whether formal or informal. This applies in particular to prices, specifications, certifications, subsidiary contracts, submission or non-submission of bids or any other actions to restrict competitiveness or to introduce cartelization in the bidding process.

2.1.3 The Bidder(s)/ Contractor(s) will not commit any penal offence under the relevant Indian Penal Code (IPC) and Prevention of Corruption Act; further the Bidder(s)/ Contractor(s) will not use improperly, for purposes of competition or personal gain, or pass on to others, any information or document provided by the Principal as part of the business relationship, regarding plans, technical proposals and business details, including information contained or transmitted electronically.

2.1.4 Foreign Bidder(s)/ Contractor(s) shall disclose the name and address of agents and representatives in India and Indian Bidder(s)/ Contractor(s) to disclose their foreign principals or associates. The Bidder(s)/ Contractor(s) will, when presenting his bid, disclose any and all payments he has made, and is committed to or intends to make to agents, brokers or any other intermediaries in connection with the award of the contract.

Place:
Date:

Signature of Authorized Signatory
with seal & full address



Bharat Heavy Electricals Limited

(A Govt. of India Undertaking)

Power Plant Piping Unit, Thirumayam – 622 507, Tamil Nadu

Tender Notice

- 2.2 The Bidder(s)/ Contractor(s) will not instigate third persons to commit offences outlined above or be an accessory to such offences.
- 2.3 The Bidder(s)/ Contractor(s) shall not approach the Courts while representing the matters to IEMs and will await their decision in the matter.

Section 3 - Disqualification from tender process and exclusion from future contracts

If the Bidder(s)/ Contractor(s), before award or during execution has committed a transgression through a violation of Section 2 above, or acts in any other manner such as to put his reliability or credibility in question, the Principal is entitled to disqualify the Bidder(s)/ Contractor(s) from the tender process or take action as per the separate "Guidelines on Banning of Business dealings with Suppliers/ Contractors", framed by the Principal.

Section 4 - Compensation for Damages

- 4.1 If the Principal has disqualified the Bidder from the tender process prior to the award according to Section 3, the Principal is entitled to demand and recover the damages equivalent Earnest Money Deposit/ Bid Security.
- 4.1 If the Principal has terminated the contract according to Section 3, or if the Principal is entitled to terminate the contract according to section 3, the Principal shall be entitled to demand and recover from the Contractor liquidated damages equivalent to 5% of the contract value or the amount equivalent to Security Deposit/ Performance Bank Guarantee, whichever is higher.

Section 5 - Previous Transgression

- 5.1 The Bidder declares that no previous transgressions occurred in the last 3 years with any other company in any country conforming to the anti-corruption approach or with any other Public Sector Enterprise in India that could justify his exclusion from the tender process.
- 5.2 If the Bidder makes incorrect statement on this subject, he can be disqualified from the tender process or the contract, if already awarded, can be terminated for such reason.

Section 6 - Equal treatment of all Bidders/ Contractors / Sub-contractors

- 6.1 The Principal will enter into agreements with identical conditions as this one with all Bidders and Contractors. In case of sub-contracting, the Principal contractor shall be responsible for the adoption of IP by his sub-contractors and shall continue to remain responsible for any default by his subcontractors.

Place:
Date:

Signature of Authorized Signatory
with seal & full address



Bharat Heavy Electricals Limited

(A Govt. of India Undertaking)

Power Plant Piping Unit, Thirumayam – 622 507, Tamil Nadu

Tender Notice

The Principal will disqualify from the tender process all bidders who do not sign this pact or violate its provisions.

Section 7 - Criminal Charges against violating Bidders/ Contractors /Subcontractors

If the Principal obtains knowledge of conduct of a Bidder, Contractor or Subcontractor, or of an employee or a representative or an associate of a Bidder, Contractor or Subcontractor which constitutes corruption, or if the Principal has substantive suspicion in this regard, the Principal will inform the Vigilance Office.

Section 8 -Independent External Monitor(s)

8.1 The Principal appoints competent and credible Independent External Monitor for this Pact. The task of the Monitor is to review independently and objectively, whether and to what extent the parties comply with the obligations under this agreement.

8.2 The Monitor is not subject to instructions by the representatives of the parties and performs his functions neutrally and independently. He reports to the CMD, BHEL.

8.3 The Bidder(s)/ Contractor(s) accepts that the Monitor has the right to access without restriction to all contract documentation of the Principal including that provided by the Bidder(s)/ Contractor(s). The Bidder(s)/ Contractor(s) will grant the monitor, upon his request and demonstration of a valid interest, unrestricted and unconditional access to his contract documentation. The same is applicable to Sub-contractor(s). The Monitor is under contractual obligation to treat the information and documents of the Bidder(s)/ Contractor(s) / Sub-contractor(s) with confidentiality in line with Non- disclosure agreement.

8.4 The Principal will provide to the Monitor sufficient information about all meetings among the parties related to the contract provided such meetings could have an impact on the contractual relations between the Principal and the Contractor. The parties offer to the Monitor the option to participate in such meetings.

8.5 The role of IEMs is advisory, would not be legally binding and it is restricted to resolving issues raised by an intending bidder regarding any aspect of the tender which allegedly restricts competition or bias towards some bidders. At the same time, it must be understood that IEMs are not consultants to the Management. Their role is independent in nature and the advice once tendered would not be subject to review at the request of the organization.

8.6 For ensuring the desired transparency and objectivity in dealing with the complaints arising out of any tendering process, the matter should be examined by the full panel of IEMs jointly as far as

Place:

Date:

Signature of Authorized Signatory
with seal & full address



Bharat Heavy Electricals Limited

(A Govt. of India Undertaking)

Power Plant Piping Unit, Thirumayam – 622 507, Tamil Nadu

Tender Notice

possible, who would look into the records, conduct an investigation, and submit their joint recommendations to the Management.

8.7 The IEMs would examine all complaints received by them and give their recommendations/ views to CMD, BHEL, at the earliest. They may also send their report directly to the CVO and the Commission, in case of suspicion of serious irregularities requiring legal/ administrative action. IEMs will tender their advice on the complaints within 10 days as far as possible.

8.8 The CMD, BHEL shall decide the compensation to be paid to the Monitor and its terms and conditions.

8.9 IEM should examine the process integrity; they are not expected to concern themselves with fixing of responsibility of officers. Complaints alleging mala fide on the part of any officer of the organization should be looked into by the CVO of the concerned organisation.

8.10 If the Monitor has reported to the CMD, BHEL, a substantiated suspicion of an offence under relevant Indian Penal Code/ Prevention of Corruption Act, and the CMD, BHEL has not, within reasonable time, taken visible action to proceed against such offence or reported it to the Vigilance Office, the Monitor may also transmit this information directly to the Central Vigilance Commissioner, Government of India.

8.11 The number of Independent External Monitor(s) shall be decided by the CMD, BHEL.

8.12 The word 'Monitor' would include both singular and plural.

Section 9 - Pact Duration

9.1 This Pact shall be operative from the date IP is signed by both the parties till the final completion of contract for successful bidder and for all other bidders 6 months after the contract has been awarded. Issues like warranty / guarantee etc. should be outside the purview of IEMs.

9.2 If any claim is made/ lodged during currency of IP, the same shall be binding and continue to be valid despite the lapse of this pact as specified above, unless it is discharged/ determined by the CMD, BHEL.

Place:
Date:

Signature of Authorized Signatory
with seal & full address



Bharat Heavy Electricals Limited

(A Govt. of India Undertaking)

Power Plant Piping Unit, Thirumayam – 622 507, Tamil Nadu

Tender Notice

ANNEXURE – 9

DECLARATION CONFIRMING KNOWLEDGE ABOUT SITE CONDITIONS

(To be typed and submitted in the Letter Head of the Company/Firm of Bidder)

To,

(Write Name & Address of Officer of BHEL inviting the Tender)

Dear Sir,

Sub: Declaration confirming knowledge about Site conditions

Ref: 1) GeM Bid Specification No:

2) All other pertinent issues till date

I/We, _____ hereby declare and confirm that we have visited the Project Site as referred in BHEL Tender Specifications and acquired full knowledge and information about the Site conditions including Wage structure, Industrial Climate, the Law & Order and other conditions prevalent at and around the Site. We further confirm that the above information is true and correct and we shall not raise any claim of any nature due to lack of knowledge of Site conditions.

I/We, hereby offer to carry out work as detailed in above mentioned Tender Specification, in accordance with Terms & Conditions thereof.

Yours faithfully,

Place:

Date:

**(Signature, Date & Seal of Authorized
Representative of the Bidder)**

Place:

Date:

Signature of Authorized Signatory
with seal & full address



Bharat Heavy Electricals Limited

(A Govt. of India Undertaking)

Power Plant Piping Unit, Thirumayam – 622 507, Tamil Nadu

Tender Notice

ANNEXURE – 10

DECLARATION

Date: _____

To,

(Write Name & Address of Officer of BHEL inviting the Tender)

Dear Sir/ Madam,

Sub: **Details of related firms and their area of activities**

Please find below details of firms owned by our family members that are doing business/ registered for same item with BHEL, _____ (NA, if not applicable)

1	Material Category/ Work Description	
	Name of Firm	
	Address of Firm	
	Nature of Business	
	Name of Family Member	
	Relationship	
2	Material Category/ Work Description	
	Name of Firm	
	Address of Firm	
	Nature of Business	
	Name of Family Member	
	Relationship	
...		

Note: I certify that the above information is true and I agree for penal action from BHEL in case any of the above information furnished is found to be false.

Regards,

(_____)

From: M/s _____

Place:
Date:

Signature of Authorized Signatory
with seal & full address



Bharat Heavy Electricals Limited

(A Govt. of India Undertaking)

Power Plant Piping Unit, Thirumayam – 622 507, Tamil Nadu

Tender Notice

Supplier Code: _____

Address: _____

Place:
Date:

Signature of Authorized Signatory
with seal & full address



Bharat Heavy Electricals Limited

(A Govt. of India Undertaking)

Power Plant Piping Unit, Thirumayam – 622 507, Tamil Nadu

Tender Notice

ANNEXURE – 11

DECLARATION FOR RELATION IN BHEL

(To be typed and submitted in the Letter Head of the Company/Firm of Bidder failing which the offer of Bidder is liable to be summarily rejected)

To,

(Write Name & Address of Officer of BHEL inviting the Tender)

Dear Sir,

Sub: Declaration for relation in BHEL

Ref: 1) GeM Bid Specification No:

I/We hereby submit the following information pertaining to relation/relatives of Proprietor/Partner(s)/ Director(s) employed in BHEL

Tick (v) any one as applicable:

1. The Proprietor, Partner(s), Director(s) of our Company/Firm DO NOT have any relation or relatives employed in BHEL

OR

2. The Proprietor, Partner(s), or Director(s) of our Company/Firm HAVE relation/relatives employed in BHEL and their particulars are as below:

- i.
- ii.

(Signature, Date & Seal of Authorized Signatory of the Bidder)

Note:

1. Attach separate sheet, if necessary.
2. If BHEL Management comes to know at a later date that the information furnished by the Bidder is false, BHEL reserves the right to take suitable against the Bidder/Contractor.

Place:
Date:

Signature of Authorized Signatory
with seal & full address



Bharat Heavy Electricals Limited

(A Govt. of India Undertaking)

Power Plant Piping Unit, Thirumayam – 622 507, Tamil Nadu

Tender Notice

ANNEXURE – 12

**DECLARATION REGARDING MINIMUM LOCAL CONTENT IN LINE WITH
REVISED PUBLIC PROCUREMENT (PREFERENCE TO MAKE IN INDIA), ORDER 2017 DATED 04TH
JUNE, 2020 AND SUBSEQUENT ORDER(S)**

(To be typed and submitted in the Letter Head of the Entity/Firm providing certificate as applicable)

To,

(Write Name & Address of Officer of BHEL inviting the Tender)

Dear Sir,

Sub: Declaration reg. minimum local content in line with Public Procurement (Preference to Make in India), Order 2017-Revision, dated 04th June, 2020 and subsequent order(s).

Ref: 1) GeM Bid Specification No:
2) All other pertinent issues till date

We hereby certify that the items/works/services offered by..... (specify the name of the organization here) has a local content of _____ % and this meets the local content requirement for 'Class-I local supplier' / 'Class II local supplier' ** as defined in Public Procurement (Preference to Make in India), Order 2017-Revision dated 04.06.2020 issued by DPIIT and subsequent order(s).

The details of the location(s) at which the local value addition is made are as follows:

1. _____
2. _____
3. _____
4. _____
- ...

Thanking you,
Yours faithfully,

**(Signature, Date & Seal of
Authorized Signatory of the Bidder)**

** - Strike out whichever is not applicable.

Place:
Date:

Signature of Authorized Signatory
with seal & full address



Bharat Heavy Electricals Limited

(A Govt. of India Undertaking)

Power Plant Piping Unit, Thirumayam – 622 507, Tamil Nadu

Tender Notice

Note:

1. Bidders to note that above format, duly filled & signed by authorized signatory, shall be submitted along with the techno-commercial offer.
2. In case the bidder's quoted value is in excess of Rs. 10 crores, the authorized signatory for this declaration shall necessarily be the statutory auditor or cost auditor of the company (in the case of companies) or a practising cost accountant or practicing chartered accountant (in respect of suppliers other than companies).
3. In the event of false declaration, actions as per the above order and as per BHEL Guidelines shall be initiated against the bidder.

Place:
Date:

Signature of Authorized Signatory
with seal & full address



Bharat Heavy Electricals Limited

(A Govt. of India Undertaking)

Power Plant Piping Unit, Thirumayam – 622 507, Tamil Nadu

Tender Notice

ANNEXURE – 13

DECLARATION REGARDING COMPLIANCE TO RESTRICTIONS UNDER RULE 144 (xi) OF GFR 2017

(To be typed and submitted in the Letter Head of the Entity/ Firm providing certificate as applicable)

To,

(Write Name & Address of Officer of BHEL inviting the Tender)

Dear Sir,

Sub: Declaration regarding compliance to Restrictions under Rule 144 (xi) of GFR 2017

Ref: 1) GeM Bid Specification No:
2) All other pertinent issues till date

I have read the clause regarding restrictions on procurement from a bidder of a country which shares a land border with India. I certify that _____ (**SPECIFY THE NAME OF THE ORGANIZATION HERE**), is not from such a country/ has been registered with the Competent Authority (*attach valid registration by the Competent Authority, i.e., the Registration Committee constituted by the Dept. for Promotion of Industry and Internal Trade (DPIIT).*)

I hereby certify that we fulfil all requirements in this regard and is eligible to be considered.

Thanking you,
Yours faithfully,

**(Signature, Date & Seal of
Authorized Signatory of the Bidder)**

Note: Bidders to note that in case above certification given by a bidder, whose bid is accepted, is found to be false, then this would be a ground for immediate termination and for taking further action in accordance with law and as per BHEL guidelines.

Place:
Date:

Signature of Authorized Signatory
with seal & full address



Bharat Heavy Electricals Limited
(A Govt. of India Undertaking)
Power Plant Piping Unit, Thirumayam – 622 507, Tamil Nadu

Tender Notice

ANNEXURE – 14

BANK ACCOUNT DETAILS FOR E-PAYMENT

(To be given on Letter head of the Company /Firm of Bidder, and **ENDORSED (SIGNED & STAMPED) BY THE BANK** to enable BHEL release payments through Electronic Fund Transfer (EFT/RTGS))

1. Beneficiary Name:

2. Beneficiary Account No.:

3. Bank Name & Branch:

4. City/Place:

5. 9-digit M ICR Code of Bank Branch:

6. IFSC Code of Bank Branch:

7. Beneficiary E-mail ID:
(for payment confirmation)

NOTE: In case Bank endorsed certificate regarding above has already been submitted earlier, kindly submit photocopy of the same

Place:
Date:

Signature of Authorized Signatory
with seal & full address



Bharat Heavy Electricals Limited

(A Govt. of India Undertaking)

Power Plant Piping Unit, Thirumayam – 622 507, Tamil Nadu

Tender Notice

ANNEXURE – 15

POWER OF ATTORNEY for SUBMISSION OF TENDER

(To be typed on non-judicial stamp paper of minimum Rs. 100/- and Notarized)

KNOW ALL MEN BY THESE PRESENTS, that I/We do hereby make, nominate, constitute and appoint Mr., whose signature given below herewith to be true and lawful Attorney of M/s..... hereinafter called 'Company', for submitting Tender/entering into Contract and inter alia, sign, execute all papers and to do necessary lawful acts on behalf of Company with M/s Bharat Heavy Electricals Ltd, Central Procurement Cell (CPC), in connection with.....vide GeM Bid No: _____, dated _____.

And the Company do hereby agree to ratify and confirm all acts, deeds, things or proceedings as may be lawfully done by the said attorney and by or on behalf of the company and in the name of the company, by virtue of the powers conferred herein and the same shall be binding on the company and shall have full force and effect.

IN WITNESS WHEREOF, the common seal of the company has been hereunto affixed in the manner hereinafter appearing on the document.

Dated at _____, this _____ day of _____

Director/CMD/Partner/Proprietor

Signature of Mr. (Attorney)

Attested by: Director/CMD/Partner/Proprietor

Witness

Notary Public

Place:
Date:

Signature of Authorized Signatory
with seal & full address



Bharat Heavy Electricals Limited
(A Govt. of India Undertaking)
Power Plant Piping Unit, Thirumayam – 622 507, Tamil Nadu

Tender Notice

ANNEXURE – 16

PROFORMA OF BANK GUARANTEE FOR EARNEST MONEY

(On non-Judicial paper of appropriate value)

Bank Guarantee No.....

Date.....

To

(Employer's Name and Address)

.....

Dear Sirs,

In accordance with the terms and conditions of Invitation for Bids/Notice Inviting Tender No.....¹(Tender Conditions), M/s. having its registered office at² (hereinafter referred to as the 'Tenderer'), is submitting its bid for the work of.....³ invited by⁴. (name of the Employer) through its Unit at(

The Tender Conditions provide that the Tenderer shall pay a sum of Rs as Earnest Money Deposit in the form therein mentioned. The form of payment of Earnest Money Deposit includes Bank Guarantee executed by a Scheduled Bank.

In lieu of the stipulations contained in the aforesaid Tender Conditions that an irrevocable and unconditional Bank Guarantee against Earnest Money Deposit for an amount of⁵ is required to be submitted by the Tenderer as a condition precedent for participation in the said Tender and the Tenderer having approached us for giving the said Guarantee,

we, the[Name & address of the Bank]

..... having our Registered Office at

..... (hereinafter referred to as the Bank) being the Guarantor under this Guarantee, hereby irrevocably and unconditionally undertake to forthwith and immediately pay to the Employer without any demur, merely on your first demand any sum or sums of Rs.

.....⁵ (in words Rupees.....) without any reservation, protest, and recourse and without the beneficiary needing to prove or demonstrate reasons for its such demand.

Any such demand made on the Bank shall be conclusive as regards the amount due and payable by the Bank under this guarantee. However, our liability under this guarantee shall be restricted to an amount not exceeding Rs. _____.

Place:

Date:

Signature of Authorized Signatory
with seal & full address



Bharat Heavy Electricals Limited

(A Govt. of India Undertaking)

Power Plant Piping Unit, Thirumayam – 622 507, Tamil Nadu

Tender Notice

We undertake to pay to the Employer any money so demanded notwithstanding any dispute or disputes raised by the Vendor/Contractor/Vendors in any suit or proceeding pending before any Court or Tribunal, Arbitrator or any other authority, our liability under this present being absolute and unequivocal.

The payment so made by us under this Guarantee shall be a valid discharge of our liability for payment hereunder and the Tenderer shall have no claim against us for making such payment.

We Bank further agree that the Employer shall have the fullest liberty without our consent and without affecting in any manner our obligations hereunder to vary any of the terms and conditions of the said Tender or to extend the time of submission of from time to time or to postpone for any time or from time to time any of the powers exercisable by the Employer against the said Tenderer and we shall not be relieved from our liability by reason of any such variation, or extension being granted to the said Tenderer or for any forbearance, act or omission on the part of the Employer or any indulgence by the Employer to the said Tenderer or by any such matter or thing whatsoever which under the law relating to sureties would but for this provision have effect of so relieving us.

The Bank also agrees that the Employer at its option shall be entitled to enforce this Guarantee against the Bank as a principal debtor, in the first instance without proceeding against the Tenderer and notwithstanding any security or other guarantee that the Employer may have in relation to the Tenderer's liabilities.

This Guarantee shall be irrevocable and shall remain in force upto and including.....⁶ and shall be extended from time to time for such period as may be desired by the Employer.

This Guarantee shall not be determined or affected by liquidation or winding up, dissolution or change of constitution or insolvency of the Tenderer but shall in all respects and for all purposes be binding and operative until payment of all money payable to the Employer in terms hereof. However, unless a demand or claim under this Guarantee is made on us in writing on or before the⁷ we shall be discharged from all liabilities under this Guarantee.

This Bank Guarantee shall be governed, construed and interpreted in accordance with the laws of India.

Courts at shall alone have exclusive jurisdiction over any matter arising out of or in connection with this Bank Guarantee

We, Bank lastly undertake not to revoke this guarantee during its currency except with the previous consent of the Employer in writing.

Notwithstanding anything to the contrary contained hereinabove:

- a. The liability of the Bank under this Guarantee shall not exceed.....⁵....

Place:

Date:

Signature of Authorized Signatory
with seal & full address



Bharat Heavy Electricals Limited

(A Govt. of India Undertaking)

Power Plant Piping Unit, Thirumayam – 622 507, Tamil Nadu

Tender Notice

- b. This Guarantee shall be valid up to⁶
- c. Unless the Bank is served a written claim or demand on or before⁷ all rights under this guarantee shall be forfeited and the Bank shall be relieved and discharged from all liabilities under this guarantee irrespective of whether or not the original bank guarantee is returned to the Bank

We, _____ Bank, have power to issue this Guarantee under law and the undersigned as a duly authorized person has full powers to sign this Guarantee on behalf of the Bank.

For and on behalf of
(Name of the Bank)

Date.....

Place of Issue.....

- 1 *Details of the Invitation to Bid/Notice Inviting Tender*
- 2 *Name and Address of the Tenderer*
- 3 *Details of the Work*
- 4 *Name of the Employer*
- 5 *BG Amount in words and Figures*
- 6 *Validity Date*
- 7 *Date of Expiry of Claim Period*

Notes:

1. Units are advised that expiry of claim period may be kept 3-6 months after validity date. It may be ensured that the same is in line with the agreement/ contract entered with the Vendor.
2. The BG should be on Non-Judicial Stamp paper/e-stamp paper of appropriate value as per Stamp Act prevailing in the State(s) where the BG is submitted or is to be acted upon or the rate prevailing in the State where the BG was executed, whichever is higher. The Stamp Paper/e-stamp paper shall be purchased in the name of Contractor/sub-contractor /vendor/ Bank issuing the guarantee.
3. In line with the GCC, SCC or contractual terms, Unit may carry out minor modifications in the Standard BG Formats. If required, such modifications may be carried out after taking up appropriately with the Unit/Region's Law Deptt.

Place:
Date:

Signature of Authorized Signatory
with seal & full address



Bharat Heavy Electricals Limited

(A Govt. of India Undertaking)

Power Plant Piping Unit, Thirumayam – 622 507, Tamil Nadu

Tender Notice

4. In Case of Bank Guarantees submitted by Foreign Vendors-

a. From Nationalized/Public Sector / Private Sector/ Foreign Banks (BG issued by Branches in India) can be accepted subject to the condition that the Bank Guarantee should be enforceable in the town/city or at nearest branch where the Unit is located i.e., Demand can be presented at the Branch located in the town/city or at nearest branch where the Unit is located.

b. From Foreign Banks (wherein Foreign Vendors intend to provide BG from local branch of the Vendor Country's Bank)

b.1 In such cases, in the Tender Enquiry/ Contract itself, it may be clearly specified that Bank Guarantee issued by **any of the Consortium Banks only** will be accepted by BHEL. As such, Foreign Vendor needs to make necessary arrangements for issuance of Counter-Guarantee by Foreign Bank in favour of the Indian Bank's (BHEL's Consortium Bank) branch in India. It is advisable that all charges for issuance of Bank Guarantee/ counter-Guarantee should be borne by the Foreign Vendor. The tender stipulation should clearly specify these requirements.

b.2 In case, Foreign Vendors intend to provide BG from Overseas Branch of our Consortium Bank (e.g. if a BG is to be issued by SBI Frankfurt), the same is acceptable. However, the procedure at **sl.no. b.1** will required to be followed.

b.3 The BG issued may preferably be subject to Uniform Rules for Demand Guarantees (URDG) 758 (as amended from time to time). The BG Format provided to them should clearly specify the same.

Place:
Date:

Signature of Authorized Signatory
with seal & full address



Bharat Heavy Electricals Limited

(A Govt. of India Undertaking)

Power Plant Piping Unit, Thirumayam – 622 507, Tamil Nadu

Tender Notice

ANNEXURE – 17

BANK GUARANTEE FOR PERFORMANCE SECURITY

(On non-Judicial paper of appropriate value)

Bank Guarantee No:

Date:

To

NAME

& ADDRESSES OF THE BENEFICIARY

Dear Sirs,

In consideration of Bharat Heavy Electricals Limited (hereinafter referred to as the 'Employer' which expression shall unless repugnant to the context or meaning thereof, include its successors and permitted assigns) incorporated under the Companies Act, 1956 and having its registered office at _____¹ through its Unit at.....(name of the Unit) having awarded to (Name of the Vendor / Contractor / Supplier) with its registered office at _____² hereinafter referred to as the 'Vendor / Contractor / Supplier', which expression shall unless repugnant to the context or meaning thereof, include its successors and permitted assigns), a contract Ref No.....dated³ valued at Rs.....⁴ (Rupees -----) / FC.....(in words.....) for⁵ (hereinafter called the 'Contract') and the Vendor / Contractor / Supplier having agreed to provide a Contract Performance Bank Guarantee, equivalent to% (.... Percent) of the said value of the Contract to the Employer for the faithful performance of the Contract,

We,, (hereinafter referred to as the Bank), having registered/Head office at and inter alia a branch at being the Guarantor under this Guarantee, hereby, irrevocably and unconditionally undertake to forthwith and immediately pay to the Employer any sum or sums upto a maximum amount of Rs -----⁶ (Rupees -----) without any demur, immediately on first demand from the Employer and without any reservation, protest, and recourse and without the Employer needing to prove or demonstrate reasons for its such demand.

Any such demand made on the Bank shall be conclusive as regards the amount due and payable by the Bank under this guarantee. However, our liability under this guarantee shall be restricted to an amount not exceeding Rs. _____.

We undertake to pay to the Employer any money so demanded notwithstanding any dispute or disputes raised by the Vendor / Contractor / Supplier in any suit or proceeding pending before any Court or

Place:

Date:

Signature of Authorized Signatory
with seal & full address



Bharat Heavy Electricals Limited

(A Govt. of India Undertaking)

Power Plant Piping Unit, Thirumayam – 622 507, Tamil Nadu

Tender Notice

Tribunal, Arbitrator or any other authority, our liability under this present being absolute and unequivocal.

The payment so made by us under this Guarantee shall be a valid discharge of our liability for payment thereunder and the Vendor / Contractor / Supplier shall have no claim against us for making such payment.

We thebank further agree that the guarantee herein contained shall remain in full force and effect during the period that would be taken for the performance of the said Contract/ satisfactory completion of the performance guarantee period as per the terms of the Contract and that it shall continue to be enforceable till all the dues of the Employer under or by virtue of the said Contract have been fully paid and its claims satisfied or discharged.

WeBANK further agree with the Employer that the Employer shall have the fullest liberty without our consent and without affecting in any manner our obligations hereunder to vary any of the terms and conditions of the said Contract or to extend time of performance by the said Vendor / Contractor / Supplier from time to time or to postpone for any time or from time to time any of the powers exercisable by the Employer against the said Vendor / Contractor / Supplier and to forbear or enforce any of the terms and conditions relating to the said Contract and we shall not be relieved from our liability by reason of any such variation, or extension being granted to the said Vendor / Contractor / Supplier or for any forbearance, act or omission on the part of the Employer or any indulgence by the Employer to the said Vendor / Contractor / Supplier or by any such matter or thing whatsoever which under the law relating to sureties would but for this provision have effect of so relieving us.

The Bank also agrees that the Employer at its option shall be entitled to enforce this Guarantee against the Bank as a principal debtor, in the first instance without proceeding against the Vendor / Contractor / Supplier and notwithstanding any security or other guarantee that the Employer may have in relation to the Vendor / Contractor / Supplier 's liabilities.

This Guarantee shall remain in force upto and including.....⁷ and shall be extended from time to time for such period as may be desired by Employer.

This Guarantee shall not be determined or affected by liquidation or winding up, dissolution or change of constitution or insolvency of the Vendor / Contractor / Supplier but shall in all respects and for all purposes be binding and operative until payment of all money payable to the Employer in terms thereof.

Unless a demand or claim under this guarantee is made on us in writing on or before the⁸ we shall be discharged from all liabilities under this guarantee thereafter.

This Bank Guarantee shall be governed, construed and interpreted in accordance with the laws of India.

Place:
Date:

Signature of Authorized Signatory
with seal & full address



Bharat Heavy Electricals Limited

(A Govt. of India Undertaking)

Power Plant Piping Unit, Thirumayam – 622 507, Tamil Nadu

Tender Notice

Courts at shall alone have exclusive jurisdiction over any matter arising out of or in connection with this Bank Guarantee

We, BANK lastly undertake not to revoke this guarantee during its currency except with the previous consent of the Employer in writing.

Notwithstanding anything to the contrary contained hereinabove:

- a. The liability of the Bank under this Guarantee shall not exceed.....⁶
- b. This Guarantee shall be valid up to⁷
- c. Unless the Bank is served a written claim or demand on or before _____⁸ all rights under this guarantee shall be forfeited and the Bank shall be relieved and discharged from all liabilities under this guarantee irrespective of whether or not the original bank guarantee is returned to the Bank.

We, _____ Bank, have power to issue this Guarantee under law and the undersigned as a duly authorized person has full powers to sign this Guarantee on behalf of the Bank.

For and on behalf of (Name of the Bank) Dated.....

Place of Issue.....

1. *NAME AND ADDRESS OF EMPLOYER i.e., Bharat Heavy Electricals Limited*
2. *NAME AND ADDRESS OF THE VENDOR /CONTRACTOR / SUPPLIER.*
3. *DETAILS ABOUT THE NOTICE OF AWARD/CONTRACT REFERENCE*
4. *CONTRACT VALUE*
5. *PROJECT/SUPPLY DETAILS*
6. *BG AMOUNT IN FIGURES AND WORDS*
7. *VALIDITY DATE*
8. *DATE OF EXPIRY OF CLAIM PERIOD*

Note:

1. Units are advised that expiry of claim period may be kept 3-6 months after validity date. It may be ensured that the same is in line with the agreement/ contract entered with the Vendor.
2. The BG should be on Non-Judicial Stamp paper/e-stamp paper of appropriate value as per Stamp Act prevailing in the State(s) where the BG is submitted or is to be acted upon or the rate prevailing in the State where the BG was executed, whichever is higher. The Stamp Paper/e-stamp paper shall be purchased in the name of Vendor/Contractor/Supplier /Bank issuing the guarantee.

Place:

Date:

Signature of Authorized Signatory
with seal & full address



Bharat Heavy Electricals Limited

(A Govt. of India Undertaking)

Power Plant Piping Unit, Thirumayam – 622 507, Tamil Nadu

Tender Notice

3. In line with the GCC, SCC or contractual terms, Unit may carry out minor modifications in the Standard BG Formats. If required, such modifications may be carried out after taking up appropriately with the Unit/Region's Law Deptt.

4. In Case of Bank Guarantees submitted by Foreign Vendors-

a. From Nationalized/Public Sector / Private Sector/ Foreign Banks (BG issued by Branches in India) can be accepted subject to the condition that the Bank Guarantee should be enforceable in the town/city or at nearest branch where the Unit is located i.e.

Demand can be presented at the Branch located in the town/city or at nearest branch where the Unit is located.

b. From Foreign Banks (wherein Foreign Vendors intend to provide BG from local branch of the Vendor Country's Bank)

b.1 In such cases, in the Tender Enquiry/ Contract itself, it may be clearly specified that Bank Guarantee issued by **any of the Consortium Banks only** will be accepted by BHEL. As such, Foreign Vendor needs to make necessary arrangements for issuance of Counter-Guarantee by Foreign Bank in favour of the Indian Bank's (BHEL's Consortium Bank) branch in India. It is advisable that all charges for issuance of Bank Guarantee/ counter- Guarantee should be borne by the Foreign Vendor. The tender stipulation should clearly specify these requirements.

b.2 In case, **Foreign Vendors intend to provide BG from Overseas Branch** of our Consortium Bank (e.g. if a BG is to be issued by SBI Frankfurt), the same is acceptable. However, the procedure at **sl.no. b.1** will required to be followed.

b.3 The BG issued may preferably be subject to Uniform Rules for Demand Guarantees (URDG) 758 (as amended from time to time). The BG Format provided to them should clearly specify the same.

Place:
Date:

Signature of Authorized Signatory
with seal & full address



Bharat Heavy Electricals Limited
(A Govt. of India Undertaking)
Power Plant Piping Unit, Thirumayam – 622 507, Tamil Nadu

Tender Notice

ANNEXURE – 18

LIST OF CONSORTIUM BANK

Sl. No.	NAME OF THE BANK
1	State Bank of India
2	Canara Bank
3	IDBI Bank Limited
4	ICICI Bank Limited
5	HDFC Bank Limited
6	Axis Bank
7	IndusInd Bank Limited
8	Bank of Baroda
9	Exim Bank
10	Indian Bank
11	Punjab National Bank
12	Union Bank of India
13	Yes Bank Limited
14	RBL Bank Ltd.
15	Indian Overseas Bank
16	Kotak Mahindra Bank Limited
17	Federal Bank Limited
18	HSBC
19	South Indian Bank
20	Bank of India

Place:
Date:

Signature of Authorized Signatory
with seal & full address



Bharat Heavy Electricals Limited

(A Govt. of India Undertaking)

Power Plant Piping Unit, Thirumayam – 622 507, Tamil Nadu

Tender Notice

ANNEXURE – 19

E-PAYMENTS

- This annexure to the techno-commercial bid explains how to make e-payments to BHEL-Tiruchirappalli through SBI e-collect.
- Vendors (SD Payments payable by others) can utilize this facility.
- Payments can be made using Internet Banking, Debit Cards/Credit Cards etc.
- SBI Charges a minimum amount (Service Charge) for every transaction. This may vary according to the MODE selected.

STEP BY STEP PROCEDURE:

Login to <https://www.onlinesbi.com>

1. Select State Bank Collect available on the top (pre login page)
2. Accept the terms and conditions and click “PROCEED”
3. Select State “TAMILNADU “and Institution type “INDUSTRY “.
4. Select “BHEL TRICHY under “INDUSTRY”.
5. In the next page, Select APPROPRIATE category, fill details correctly & click “SUBMIT”.
6. If all details entered are correctly populated, click “CONFIRM “to proceed.
7. Make payment as per your convenience. (Options available are payment of fees through SBI Net Banking, State Bank ATM cum Debit Cards / Other Bank Debit / Credit Cards and through SBI Branches).
8. SAVE & Keep the copy of receipt for future reference.

HOW TO TAKE RECEIPT FOR A PAYMENT MADE, EVEN ON A LATER DATE:

(PLEASE CHECK THE STATUS BEFORE MAKING PAYMENT SECOND TIME)

1. Login to www.onlinesbi.com
2. Select State Bank Collect available on the top (pre login page)
3. Accept the terms and conditions and click “PROCEED”
4. Select “PAYMENT HISTORY “option available on the left side of screen.
5. Using two options as mentioned below, you can get the receipt:
 - a. Type the same Date of Birth, Mobile Number which you have entered at the time of making payment through SB collect. Select the date range and submit.
 - b. If you know the payment reference number, then enter the Reference number (DU...) along with anyone information (Date of Birth / Mobile number, which you have entered at the time of making payment). Select the date range and submit.
6. In the next page, take print out of receipt.

Place:
Date:

Signature of Authorized Signatory
with seal & full address



Bharat Heavy Electricals Limited

(A Govt. of India Undertaking)

Power Plant Piping Unit, Thirumayam – 622 507, Tamil Nadu

Tender Notice

ANNEXURE-20

Format of Letter Confirming the Lien on Fixed Deposit Receipt (On the Letter Head of Bank)

Reference No.....

Date:

To

M/s Bharat Heavy Electricals Limited,
Finance Department, 2ND floor admin
building,
THIRUMAYAM-620014.

Dear Sir /Madam,

We refer to the fixed deposit receipt (FDR) bearing no. _____ dated
_____ for Rs. _____ issued in the name of Bharath Heavy Electricals
Ltd. (BHEL) Trichy-14. Account of ____ (Name of the vendor)

We hereby agree and confirm that,

1. There is no lock in period for encashment of the said FDR.
2. The amount under the said FDR would be paid to you on demand, at any point of time before, or upon maturity, without any reference to the _____ (name of the vendor).
3. Encashment whether premature or otherwise would not require any clearance from any other authority / person.
4. We agree that on encashment of FDR, the interest accrued will also be released to you.
5. We agree that the FDR will be auto renewed for such period/s initially mentioned in the FDR and the intimation of such renewal shall be sent to BHEL, Trichy-14 and(the name of the vendor) immediately after the renewal.
6. FDR will not be closed, encashed, changed or Discharged without the written permission / confirmation from M/s. BHEL, Trichy.
7. We acknowledge and agree that the Lien created on the FDR shall be in force until BHEL, Trichy gives us a Discharge Letter in this regard.

Place:

Date:

Signature of Authorized Signatory
with seal & full address



Bharat Heavy Electricals Limited
(A Govt. of India Undertaking)
Power Plant Piping Unit, Thirumayam – 622 507, Tamil Nadu

Tender Notice

Yours faithfully,

Authorised Signatory
(Bank Stamp/Seal)

This letter to be typed on Bank's letter head,

Bank email id:

Mobile no:

Landline no:

Address for communication:

Place:
Date:

Signature of Authorized Signatory
with seal & full address



Bharat Heavy Electricals Limited

(A Govt. of India Undertaking)

Power Plant Piping Unit, Thirumayam – 622 507, Tamil Nadu

Tender Notice

Annexure-21

GENERAL DETAILS:

(To be filled by Bidder)

Tender Ref: PPPU: WC: 26: 008

01	Name and full address of the Company / Firm	
02	Name of contact Person with Designation	
03	Contact Details:	
	Landline No.	
	Mobile No.	
	email ID:	
04	Local Office Address with Contact person, Phone No., Mobile No., email ID, Fax No. (If any)	
05	Vendor code allotted by BHEL if any	
06	List of BHEL units in which vendor has executed any type of contract previously or is currently executing any type of contract	
07	Is the vendor under Ban Or Hold by any units of BHEL?	
08	Applicable GST percentage for this tender	

Place:
Date:

Signature of Authorized Signatory
with seal & full address



Bharat Heavy Electricals Limited
(A Govt. of India Undertaking)
Power Plant Piping Unit, Thirumayam – 622 507, Tamil Nadu

Tender Notice

General Conditions of Contract (GCC)

BHARAT HEAVY ELECTRICALS LIMITED
(A Govt. of India Undertaking)
Power Plant Piping Unit, Thirumayam – 622 507, Tamil Nadu

Place:
Date:

Signature of Authorized Signatory
with seal & full address



Bharat Heavy Electricals Limited

(A Govt. of India Undertaking)

Power Plant Piping Unit, Thirumayam – 622 507, Tamil Nadu

Tender Notice

TABLE OF CONTENTS

1. **Chapter-1:** General Instructions to Tenderers
 - 1.1. Despatch Instructions
 - 1.2. Submission of Tenders
 - 1.3. Qualification of Tenderers
 - 1.4. Evaluation of Bids
 - 1.5. Data to be enclosed
 - 1.6. Authorization and Attestation
 - 1.7. Earnest Money Deposit
 - 1.8. Security Deposit
 - 1.9. Return of Security Deposit
 - 1.10. Bank Guarantee
 - 1.11. Validity of offer
 - 1.12. Rejection of Tender and other Conditions
 - 1.13. Intimation of change of name/re-constitution of the Organization

2. **Chapter-2:**
 - 2.1. Definitions
 - 2.2. Law Governing Contract and Court Jurisdiction
 - 2.3. Issue of Notice
 - 2.4. Use of Land
 - 2.5. Commencement of Work
 - 2.6. Measurement of Work and Mode of Payment
 - 2.7. Rights of BHEL
 - 2.8. Responsibilities of Contractor in respect of Local Laws, Employment of Workers etc
 - 2.9. Progress Monitoring, Monthly Review and Performance Evaluation
 - 2.10. Time of Completion
 - 2.11. Extension of Time for Completion
 - 2.12. Insurance
 - 2.13. Strikes & Lockout
 - 2.14. Force Majeure
 - 2.15. Settlement of Disputes
 - 2.16. Closing of Contracts
 - 2.17. Suspension of Business Dealings
 - 2.18. Limitation on Liability
 - 2.19. Other Issues

Place:
Date:

Signature of Authorized Signatory
with seal & full address



Bharat Heavy Electricals Limited

(A Govt. of India Undertaking)

Power Plant Piping Unit, Thirumayam – 622 507, Tamil Nadu

Tender Notice

CHAPTER -1

1. GENERAL INSTRUCTION TO TENDERERS

1.1. DESPATCH INSTRUCTION

- i. The General Conditions of Contract form part of the Tender specifications. **For this tender, bidders shall use electronic Signature viz Digital Signature Certificate while uploading the tender documents on the e-procurement portal.** The information furnished shall be complete by itself. The tenderer is required to furnish all the details and other documents as required in the following pages.
- ii. Tenderers are advised to study all the tender documents carefully. Any submission of tender by the tenderer shall be deemed to have been done after careful study and examination of the tender documents and with the full understanding of the implications thereof. Should the tenderers have any doubt about the meaning of any portion of the Tender Specification or find discrepancies or omissions in the drawings or the tender documents issued are incomplete or shall require clarification on any of the technical aspect, the scope of work etc., he shall at once, contact the authority inviting the tender well in time (so as not to affect last date of submission) for clarification before the submission of the tender. Tenderer's request for clarifications shall be with reference to Sections and Clause numbers given in the tender documents. The specifications and terms and conditions shall be deemed to have been accepted by the tenderer in his offer. Non-compliance with any of the requirements and instructions of the tender enquiry may result in the rejection of the tender.
- iii. Integrity pact (IP) shall be applicable for all tenders / contracts if indicated in NIT. This IP shall be issued as part of the Tender documents and shall be submitted by the bidder along with Techno-commercial bid duly filled, signed and stamped by the authorized signatory who signs the bid. Entering into this pact shall be a preliminary qualification.

1.2. SUBMISSION OF TENDERS

- 1.2.1. The tenderers must submit their tenders to Officer inviting tender as per instructions in the NIT.
- 1.2.2. Tenders shall be submitted through E-Procurement portal as per instruction in NIT. Tenderers to upload offers well in advance in order to avoid last minute congestion in e-procurement website. However, after submission of the tender, the tenderer can re-submit revised tender but before due date and time of submission of tender as notified.
- 1.2.3. Tenders shall be opened by Officer of BHEL at the time and date as specified in the NIT. For this tender, bidders may attend through online mode, if provisions are available in e-procurement portal.
- 1.2.4. Tenderers whose bids are found techno commercially qualified shall be notified through e-procurement system about the date and time of opening of the Price Bids. BHEL's decision in this regard shall be final and binding.

Place:
Date:

Signature of Authorized Signatory
with seal & full address



Bharat Heavy Electricals Limited

(A Govt. of India Undertaking)

Power Plant Piping Unit, Thirumayam – 622 507, Tamil Nadu

Tender Notice

- 1.2.5. The information given in the tender documents is for general guidance and shall not be construed as contractually binding on BHEL/ Owner. All relevant site data/ information as may be necessary for bidding shall have to be obtained/ collected by the Tenderer.
- 1.2.6. The Tenderers are advised to physically visit the site to acquaint and satisfy themselves about the weather conditions, working culture in the area, socio-political environment, safety & security aspects, law & order situation, law of the land, transportation routes, various distances, surroundings of plant/ project premises together with all statutory, obligatory, mandatory requirements of various authorities and obtain for themselves all necessary information as to the risks, contingencies and all other circumstances, which may influence or affect the discharge of various obligations under the Contract during contract period including extended period (if any).
- 1.2.7. The submission of bid will tantamount to due diligence having been done and it shall be deemed that:
- a) the Tenderer has obtained all necessary information as to risks, contingencies and other circumstances which may influence or affect the Works
 - b) the Tenderer accepts total responsibility for having foreseen all difficulties and costs of successfully completing the Works
 - c) the Tenderer accepts that, the Contract Price shall not be adjusted to take account of any unforeseeable or unforeseen difficulties or costs and the Tenderer shall not raise any claims/ disputes against BHEL and/ or Owner at later date in any manner whatsoever.

1.3. QUALIFICATION OF TENDERERS

- i. Only tenderers who have previous experience in the work of the nature and description detailed in the Notice Inviting Tender and/or tender specification are expected to quote for this work duly detailing their experience along with offer.
- ii. Offers from tenderers who do not have proven and established experience in the field shall not be considered.
- iii. The offers of the bidders who are on the debarred list shall be rejected. Further, offer of the bidders, who engage the services of the debarred firms or associated with the debarred firm, for present bid, shall also be rejected. The list of **debarred firms** is available on BHEL web site www.bhel.com. (Refer clause 28.0 of NIT).
- iv. Tenderers who have been suspended, debarred or black listed by BHEL, Tiruchirappalli - 620014 or any other unit of BHEL/ any other PSU or GOI/ any State Govt. or against whom incident (live) raised by BHEL Thirumayam in GeM will not be allowed to participate in the tender, and bidder should declare in the tender that they are not suspended, debarred or blacklisted by any of the agencies stated above. Even during the course of evaluation/ finalization of tender if it is found that a bidder is so suspended, debarred or black listed, BHEL shall not consider them for further participation in the tender.
- v. Offers from tenderers who do not comply with the latest guidelines of Ministry/Commissions of Govt. of India shall not be considered.

Place:
Date:

Signature of Authorized Signatory
with seal & full address



Bharat Heavy Electricals Limited

(A Govt. of India Undertaking)

Power Plant Piping Unit, Thirumayam – 622 507, Tamil Nadu

Tender Notice

1.4. EVALUATION OF BIDS

- i. Technical Bids submitted by the tenderer will be opened first and evaluated for fulfilling the Pre- Qualification criteria and other conditions in NIT/Tender documents, based on documentary evidences submitted along with the offer.
- ii. In case the same qualifying experience is claimed by more than one agency, then:
 - a. The agency who has executed the work as per documentary evidence submitted shall only be qualified. Scope of qualifying work should be totally with the agency who has executed and in case it is only labour and consumables without T&P, then the credentials of execution is assigned to the first agency and not to the agency who has executed only as labour supply contractor. Further, BHEL reserves the right to ask for any other proof for the said job.
 - b. However, if the same is on account of subletting, part of scope by one agency to another agency in a project of BHEL, experience of both the agencies may be considered for the sublet portion of the work provided subletting has been done with the approval of BHEL.
- iii. In case the qualifying experience is claimed by bidder is based on 'Work Order' and 'Experience Certificates' from any organization other than BHEL (main agency), then it shall be the responsibility of the bidder to submit (in addition to the experience certificate from main agency) relevant certificate regarding qualifying experience from the end Customer or the Turnkey-Contractor (if any) who has awarded the work to main agency, as a proof for having executed subject qualifying work. BHEL reserves the right to ask for any other proof for the said job.
- iv. Assessing Bidder's Capacity for executing the current tender shall be as per Notice Inviting Tender.
- v. Price Bids of shortlisted bidders shall only be opened through the electronic price bid opening with/without Reverse Auction, at the discretion of BHEL. Unless specified otherwise in the tender, the L1 bidder amongst all the shortlisted bidders shall be considered for award. However, the L1 bidder shall have no claim on the award & BHEL reserves the right to award the tender at its sole discretion.
- vi. Price Bids of unqualified bidders shall not be opened. Reasons for rejection shall be intimated in due course either through system generated e-mail or through letter/e-mail after award to successful bidder.
- vii. Bidders are advised to also refer to clause no 2.9.4 regarding evaluation of their performance in ongoing projects.

1.5. DATA TO BE ENCLOSED

Full information shall be given by the tenderer in respect of the following. Non-submission of this information may lead to rejection of the offer.

i. INCOME TAX PERMANENT ACCOUNT NUMBER

Certified copies of Permanent Account Numbers as allotted by Income Tax Department for the Company/Firm/Individual Partners etc. shall be furnished along with tender.

Place:
Date:

Signature of Authorized Signatory
with seal & full address



Bharat Heavy Electricals Limited

(A Govt. of India Undertaking)

Power Plant Piping Unit, Thirumayam – 622 507, Tamil Nadu

Tender Notice

- ii. An attested copy of the Power of Attorney, in case the tender is signed by an individual other than the sole proprietor.
- iii. **IN CASE OF INDIVIDUAL TENDERER:**
His / her full name, address, PAN and place & nature of business.
- iv. **IN CASE OF PARTNERSHIP FIRM:**
The names of all the partners and their addresses, copy of the **partnership deed/instrument of partnership dully certified by the Notary Public shall be enclosed.**
- v. **IN CASE OF COMPANIES:**
 - a) Date and place of registration including date of commencement certificate in case of Public Companies (certified copies of Memorandum and articles of Association are also to be furnished).
 - b) Nature of business carried on by the Company and the provisions of the Memorandum relating thereof.

1.6. AUTHORIZATION AND ATTESTATION

Tenders shall be signed by a person duly authorized/empowered to do so, for which a Power of Attorney is to be submitted along with the tender offer. For company, a Power of Attorney (as per format in Volume-I D) shall be submitted.

1.7. EARNEST MONEY DEPOSIT(Not applicable)

- 1.7.1. Every tender must be accompanied by the prescribed amount of Earnest Money Deposit (EMD) in the manner described herein.
 - i. EMD shall be furnished before tender opening / along with the offer in full as per the amount indicated in the NIT.
 - ii. The EMD up to an amount of Rs. 2 Lakh is to be paid only in the following forms:
 - a) Cash deposit as permissible under the extant Income Tax Act (before tender opening).
 - b) Electronic Fund Transfer credited in BHEL account (before tender opening).
 - c) Banker's cheque / Pay order / Demand draft, in favour of 'Bharat Heavy Electricals Limited' and payable at Regional HQ issuing the tender (along with offer).
 - d) Fixed Deposit Receipt (FDR) issued by Scheduled Banks/ Public Financial Institutions as defined in the Companies Act (FDR should be in the name of the Contractor, a/c BHEL) duly marking lien in favour for BHEL (along with offer). The Fixed Deposit in such cases shall be valid for at least six months from the due date of tender submission.
 - e) Insurance Surety Bonds
 - f) In case EMD amount is more than Rs. Two Lakhs, Tenderer has the option to submit the amount in excess of Rs. Two lakhs in the forms described above in clause no. 1.9.1. ii) (a) to (e) or in the form of Bank Guarantee from Scheduled Bank (along with the Offer). The Bank Guarantee in such cases shall be valid for at least six months from the due date of tender submission. The Bank Guarantee format for EMD shall be in the prescribed formats.

Place:
Date:

Signature of Authorized Signatory
with seal & full address



Bharat Heavy Electricals Limited

(A Govt. of India Undertaking)

Power Plant Piping Unit, Thirumayam – 622 507, Tamil Nadu

Tender Notice

- iii. No other form of EMD remittance shall be acceptable to BHEL.
 - iv. Proof of EMD: Bidder shall upload the scanned copy of EMD along with bid submission through BHEL e-procurement Portal. However, for the purpose of realization, the bidder shall send the demand draft/ banker's cheque/ pay order/ Bank Guarantee/ FDR/ Insurance Surety Bonds, in original, to the designated officer through post/courier or by hand within reasonable time.
- 1.7.2. EMD by the Tenderer will be forfeited as per NIT conditions, if:
- i. After opening the tender and within the offer validity period, the tenderer revokes his tender or makes any modification in his tender which is not acceptable to BHEL.OR
 - ii. The successful Contractor, on whom the work has been awarded, fails to deposit the required Security deposit or commence the work within the period as per LOI/ LOA/ Contract or refuse to accept the LIO/LOA/Contract.
 - iii. EMD by the tenderer shall be withheld in case any action on the tenderer is envisaged under the provisions of extant "Guidelines on Suspension of business dealings with suppliers/ contractors" of BHEL and forfeited/ released based on the action as determined under these guidelines.
- 1.7.3. EMD shall not carry any interest.
- 1.7.4. EMD given by all unsuccessful tenderers shall be refunded normally within fifteen days of award of work.
- 1.7.5. Cash portion of EMD of successful tenderer will be retained as part of Security Deposit. EMD submitted in the form of Bank Guarantee/ FDR shall be retained by BHEL until the receipt of the Security Deposit.
- 1.7.6. Micro and Small Enterprises (MSEs) or Start-ups as recognized by Department for Promotion of Industry and Internal Trade (DPIIT) shall be exempted from payment of EMD
- 1.8. SECURITY DEPOSIT**
- 1.8.1. Upon acceptance of Tender, the successful bidder shall be required to deposit the 5% of the contract value as Security Deposit towards fulfilment of any obligations in terms of the provisions of the contract.
- 1.8.2. The Security Deposit shall be furnished before start of the work by the contractor.
- 1.8.3. The required Security Deposit may be accepted in the following forms.
- i. Cash (as permissible under the extant Income Tax Act).
 - ii. Local cheques of Scheduled Banks (subject to realization)/ Pay Order/ Demand Draft/ Electronic Fund Transfer in favour of BHEL.
 - iii. Securities available from Indian Post offices such as National Savings Certificates, Kisan Vikas Patras etc. (held in the name of Contractor furnishing the security and duly endorsed/ hypothecated/ pledged, as applicable, in favour of BHEL).

Place:
Date:

Signature of Authorized Signatory
with seal & full address



Bharat Heavy Electricals Limited

(A Govt. of India Undertaking)

Power Plant Piping Unit, Thirumayam – 622 507, Tamil Nadu

Tender Notice

- iv. **Bank Guarantee from Scheduled Banks/ Public Financial Institutions as defined in** the Companies Act. The Bank Guarantee format for Security Deposit shall be in the prescribed formats.
- v. Insurance Surety Bonds.

Note:

- i. BHEL will not be liable or responsible in any manner for the collection of interest or renewal of the documents or in any other matter connected therewith.
 - ii. In case of delay in submission of Security Deposit, enhanced security deposit which would include interest (Repo rate + 4%) for the delayed period, shall be submitted by the bidder before submission of first bill
- 1.8.4. The Security Deposit shall not carry any interest.
- 1.8.5. In case the value of work exceeds the awarded / accepted value, the Security Deposit shall be correspondingly enhanced as given below:
- i. The enhanced part of the Security Deposit shall be immediately deposited by the Contractor or adjusted against payments due to the Contractor.
 - ii. Contract value for the purpose of operating the increased value of Security Deposit due to Quantity Variation, shall be exclusive of Price Variation Clause, Over Run Compensation and Extra works done on man-day rates.
 - iii. The recoveries made from running bills can be released against submission of equivalent Bank Guarantee in acceptable form, but only once, before completion of work, with the approval of competent authority of BHEL.
- 1.8.6. The validity of Bank Guarantees towards Security Deposit shall be initially up to the completion period as stipulated in the Letter of Intent/ Award + Guarantee Period + 3 months, and the same shall be kept valid by proper renewal by the contractor till the acceptance of Final Bills of the Contractor by BHEL
- 1.8.7. BHEL reserves the right of forfeiture of Security Deposit in addition to other claims, damages and remedies in the event of the Contractor's failure to fulfil any of the contractual obligations or in the event of termination of contract as per terms and conditions of contract. BHEL reserves the right to set off the Security Deposit against any claims of other contracts with BHEL by giving prior notice to the contractor.
- 1.8.8 There is no exemption of Performance security deposit submission for MSE / Start-Ups Vendors.

1.9. RETURN OF SECURITY DEPOSIT

Security Deposit shall be released to the contractor upon fulfillment of contractual obligations as per terms of the contract including completion of Guarantee Period after deducting all expenses / other amounts due to BHEL under the contract.

1.10. BANK GUARANTEES

Place:
Date:

Signature of Authorized Signatory
with seal & full address



Bharat Heavy Electricals Limited

(A Govt. of India Undertaking)

Power Plant Piping Unit, Thirumayam – 622 507, Tamil Nadu

Tender Notice

Where ever Bank Guarantees are to be furnished/submitted by the contractor, the following shall be complied with

- i. Bank Guarantees shall be from Scheduled Banks / Public Financial Institutions as defined in the Companies Act. Bank Guarantees issued by Co-Operative Banks/ Financial Institutions shall not be accepted.
- ii. The Bank Guarantees shall be as per prescribed formats.
- iii. It is the responsibility of the bidder to get the Bank Guarantees revalidated/extended for the required period as per the advice of BHEL Site Engineer / Construction Manager. BHEL shall not be liable for issue of any reminders regarding expiry of the Bank Guarantees.
- iv. In case extension/further extensions of any Bank Guarantees are not required, the bidders shall ensure that the same is explicitly endorsed by the Construction Manager and submitted to the Regional HQ issuing the LOI/LOA.
- v. In case the Bank Guarantees are not extended before the expiry date, BHEL reserves the right to invoke the same by informing the concerned Bank in writing, without any advance notice/communication to the concerned bidder.
- vi. Bidders to note that any corrections to Bank Guarantees shall be done by the issuing Bank, only through an amendment in an appropriate non judicial stamp paper.
- vii. The Original Bank Guarantee shall be submitted to contracting Department

1.11. VALIDITY OF OFFER

The rates in the Tender shall be kept open for acceptance for a minimum period of **SIX MONTHS** from latest due date of offer submission (including extension, if any). In case BHEL (Bharat Heavy Electricals Ltd) calls for negotiations, such negotiations shall not amount to cancellation or withdrawal of the original offer which shall be binding on the tenderers.

1.12. REJECTION OF TENDER AND OTHER CONDITIONS

- 1.12.1. The acceptance of tender will rest with BHEL which does not bind itself to accept the lowest tender nor any tender and reserves to itself full rights for the following without assigning any reasons whatsoever: -
 - a) To reject any or all of the tenders.
 - b) To split up the work amongst two or more tenderers as per NIT.
 - c) To award the work in part if specified in NIT.
 - d) In case of either of the contingencies stated in (b) and (c) above, the time for completion as stipulated in the tender shall be applicable.
- 1.12.2. Conditional tenders, unsolicited tenders, tenders which are incomplete or not in the form specified or defective or have been materially altered or not in accordance with the tender conditions, specifications etc. are liable to be rejected.
- 1.12.3. Tenders are liable to be rejected in case of unsatisfactory performance of the tenderer with BHEL or tenderer under suspension (debarred) by any unit / region / division of BHEL or

Place:
Date:

Signature of Authorized Signatory
with seal & full address



Bharat Heavy Electricals Limited

(A Govt. of India Undertaking)

Power Plant Piping Unit, Thirumayam – 622 507, Tamil Nadu

Tender Notice

tenderers who do not comply with the latest guidelines of Ministry/Commissions of Govt of India. BHEL reserves the right to not consider a bidder for further processing of tender in case it is observed that they are overloaded and may not be in a position to execute this job as per the required schedule **in line with clause no. 9.0 of the 'NIT'**. The decision of BHEL will be final in this regard.

- 1.12.4. If a tenderer who is a proprietor expires after the submission of his tender or after the acceptance of his tender, BHEL may at their discretion, cancel such tender. If a partner of a firm expires after the submission of tender or after the acceptance of the tender, BHEL may then cancel such tender at their discretion, unless the firm retains its character. In case BHEL resolves to cancel the tender under this clause, BHEL will issue a notice in this regard containing reasons as to the cancellation of tender. The contractor shall be required to furnish his response to such notice within a period of 14 days from the date of receipt of such notice through any means (BHEL reserves the right to decrease the period upto 05 days). BHEL after due consideration of the representation made by contractor shall communicate its final decision within a reasonable period.

In case contractor fails to submit any response to the notice issued by BHEL within the period stipulated in the notice, BHEL at its discretion may proceed to cancel the contract.

Contractor shall not be eligible for any compensation whatsoever for the cancellation of contract under this clause

- 1.12.5. BHEL will not be bound by any Power of Attorney granted by changes in the composition of the firm made subsequent to the execution of the contract. BHEL may, however, recognize such power of Attorney and changes after obtaining proper legal advice, the cost of which will be chargeable to the contractor concerned.
- 1.12.6. If the tenderer deliberately gives wrong information in his tender, BHEL reserves the right to reject such tender at any stage or to cancel the contract if awarded and forfeit the Earnest Money/Security Deposit/any other money due.
- 1.12.7. Canvassing in any form in connection with the tenders submitted by the Tenderer shall make his offer liable to rejection.
- 1.12.8. In case the Proprietor, Partner or Director of the Company/Firm submitting the Tender, has any relative or relation employed in BHEL, the authority inviting the Tender shall be informed of the fact as per specified format, along with the Offer. Failing to do so, BHEL may, at its sole discretion, reject the tender or cancel the contract and forfeit the Earnest Money/Security Deposit.
- 1.12.9. The successful tenderer (Contractor) shall not sub-contract any portion of work detailed in the tender specification undertaken by him without written permission of BHEL's Construction Manager/Site in charge. BHEL, at its discretion, may consider the written request from the Contractor and permit subletting of part scope. However, the Contractor is solely responsible to BHEL for the work awarded to him.

Place:
Date:

Signature of Authorized Signatory
with seal & full address



Bharat Heavy Electricals Limited

(A Govt. of India Undertaking)

Power Plant Piping Unit, Thirumayam – 622 507, Tamil Nadu

Tender Notice

1.12.10. The Tender submitted by a techno commercially qualified tenderer shall become the property of BHEL who shall be under no obligation to return the same to the bidder.

1.12.11. Unsolicited discount received after the due date and time of Bid Submission shall not be considered for evaluation. However, if the party who has submitted the unsolicited discount/rebate becomes the L-1 party, then the awarded price i.e. contract value shall be worked out after considering the discount so offered.

1.12.12. BHEL shall not be liable for any expenses incurred by the bidder in the preparation of the tender irrespective of whether the tender is accepted or not.

1.13. INTIMATION OF CHANGE OF NAME/ RE-CONSTITUTION OF THE ORGANIZATION

In the event of the organization (Proprietorship/Partnership/Company) undergoing any change of name or reconstitution, prior intimation of the same shall be given to BHEL. Upon such changes coming into effect, the same is to be intimated to BHEL immediately with supporting documents as applicable.

Further, the new entity has to give undertaking in writing that they will honor all the earlier commitments in respect of the subject contract.

CHAPTER -2

2.1. **DEFINITION:** The following terms shall have the meaning hereby assigned to them except where the context otherwise requires

- i. BHEL shall mean Bharat Heavy Electricals Limited, a company registered under Indian Companies Act 1956, having its Registered Office at BHEL HOUSE, SIRI FORT, NEW DELHI – 110 049, and its CPC (Central Procurement Cell) -PSHQ (inviting tenders) or its Power Sector Regional Offices or its Authorized Officers or its Site Engineers or other employees authorized to deal with any matters with which these persons are concerned on its behalf.
- ii. “EXECUTIVE DIRECTOR” or “GENERAL MANAGER (In- charge)” or “GENERAL MANAGER” shall mean the Officer in Administrative charge of the respective UNIT/Power Sector Region.
- iii. “COMPETENT AUTHORITY” shall mean BHEL Officers who are empowered to act on behalf of BHEL.
- iv. “ENGINEER” or “ENGINEER IN CHARGE” shall mean an Officer of BHEL as may be duly appointed and authorized by BHEL to act as “Engineer” on his behalf for the purpose of the Contract, to perform the duty set forth in this General Conditions of Contract and other Contract documents. The term also includes ‘CONSTRUCTION MANAGER’ or ‘SITE INCHARGE’ as well as Officers at Site or at the Headquarters of the respective Power Sector Regions.
- v. “SITE” shall mean the places or place at which the plants/equipments are to be erected and services are to be performed as per the specification of this Tender.
- vi. “CLIENT OF BHEL” or “CUSTOMER” shall mean the project authorities with whom BHEL has entered into a contract for supply of equipments or provision of services.
- vii. “CONTRACTOR” shall mean the successful Bidder/Tenderer who is awarded the Contract and shall include the Contractor’s successors, heirs, executors, administrators and permitted assigns.

Place:
Date:

Signature of Authorized Signatory
with seal & full address



Bharat Heavy Electricals Limited

(A Govt. of India Undertaking)

Power Plant Piping Unit, Thirumayam – 622 507, Tamil Nadu

Tender Notice

- viii. “CONTRACT” or “CONTRACT DOCUMENT” shall mean and includes the Agreement or Work Order, the accepted appendices of Rates, Schedules, Quantities if any, Offer submitted by contractor including acceptance to General Conditions of Contract, Special Conditions of Contract, Instructions to the Tenderers, Drawings, Technical Specifications, the Special Specifications if any, the Tender documents, subsequent amendments /corrigendum to Tender mutually agreed upon and the Letter of Intent/Award/Acceptance issued by BHEL. Any conditions or terms stipulated by the contractor in the tender documents or subsequent letters shall not form part of the contract unless, specifically accepted in writing by BHEL in the Letter of Intent/Award and incorporated in the agreement or amendment thereof.
- ix. “GENERAL CONDITIONS OF CONTRACT” shall mean the ‘Instructions to Tenderers’ and ‘General Conditions of Contract’ pertaining to the work for which above tenders have been called for.
- x. “TENDER SPECIFICATION” or “TENDER” or “TENDER DOCUMENTS” shall mean General Conditions, Common Conditions, Special Conditions, Price Bid, Rate Schedule, Technical Specifications, Appendices, Annexures, Corrigendums, Amendments, Forms, Procedures, Site information etc. and drawings/documents pertaining to the work for which the tenderers are required to submit their offers. Individual specification number will be assigned to each Tender Specification.
- xi. “LETTER OF INTENT/ AWARD” shall mean the intimation by a Letter/Fax/email to the tenderer that the tender has been accepted in accordance with provisions contained in the letter. The responsibility of the contractor commences from the date of issue of this letter and all terms and conditions of the contract are applicable from this date.
- xii. “COMPLETION TIME” shall mean the period by ‘date/month’ specified in the ‘Letter of Intent/Award’ or date mutually agreed upon for handing over of the intended scope of work, the erected equipment/plant which are found acceptable by the Engineer, being of required standard and conforming to the specifications of the Contract.
- xiii. “PLANT” shall mean and connote the entire assembly of the plant and equipments covered by the contract.
- xiv. “EQUIPMENT” shall mean equipment, machineries, materials, structural, electricals and other components of the plant covered by the contract.
- xv. “TESTS” shall mean and include such test or tests to be carried out on the part of the contractor as are prescribed in the contract or considered necessary by BHEL in order to ascertain the quality, workmanship, performance and efficiency of the contractor or part thereof.
- xvi. “APPROVED”, “DIRECTED” or “INSTRUCTED” shall mean approved, directed or instructed by BHEL.
- xvii. “WORK or CONTRACT WORK” shall mean and include supply of all categories of labour, specified consumables, tools and tackles and Plants required for complete and satisfactory site

Place:
Date:

Signature of Authorized Signatory
with seal & full address



Bharat Heavy Electricals Limited

(A Govt. of India Undertaking)

Power Plant Piping Unit, Thirumayam – 622 507, Tamil Nadu

Tender Notice

transportation, handling, stacking, storing, erecting, testing and commissioning of the equipments to the entire satisfaction of BHEL.

- xviii. "SINGULAR AND PLURALS ETC" words carrying singular number shall also include plural and vice versa, where the context so requires. Words imparting the masculine Gender shall be taken to include the feminine Gender and words imparting persons shall include any Company or Associations or Body of Individuals, whether incorporated or not.
- xix. "HEADING" – The heading in these General Conditions are solely for the purpose of facilitating reference and shall not be deemed to be part thereof or be taken as instructions thereof or of the contract.
- xx. "MONTH" shall mean calendar month unless otherwise specified in the Tender.
- xxi. 'Day' or 'Days' unless herein otherwise expressly defined shall mean calendar day or days of twenty-four (24) hours each. A Week shall mean continuous period of seven (7) days.
- xxii. "COMMISSIONING" shall mean the synchronization testing and achieving functional operation of the Equipment with associated system after all initial adjustments, trials, cleaning, re-assembly required at site if any, have been completed and Equipment with associated system is ready for taking into service.
- xxiii. "WRITING" shall include any manuscript type written or hand written or printed statement or electronically transmitted messages, under the signature or seal or transmittal of BHEL.
- xxiv. "TEMPORARY WORK" shall mean all temporary works for every kind required in or for the execution, completion, maintenance of the work.
- xxv. 'CONTRACT PRICE' or 'CONTRACT VALUE' shall mean the sum mentioned in the LOI/LOA/Contract Agreement subject to such additions thereto or deductions there from as may be made under provisions hereinafter contained.
- xxvi. 'EXECUTED CONTRACT VALUE' shall mean actual value of works executed by the contractor and certified by BHEL. This value shall not include PVC, ORC, Extra Works and Taxes.
- xxvii. "COMMENCEMENT DATE" or "START DATE" shall mean the commencement/start of work at Site as per terms defined in the Tender.
- xxviii. "SHORT CLOSING" or "FORE CLOSING" of Contract shall mean the premature closing of Contract, for reasons not attributable to the contractor and mutually agreed between BHEL and the contractor.
- xxix. "TERMINATION" of Contract shall mean the pre mature closing of contract due to reasons as mentioned in the contract.
- xxx. "DE MOBILIZATION" shall mean the temporary winding up of Site establishment by Contractor leading to suspension of works temporarily for reasons not attributable to the contractor.
- xxxi. "RE MOBILIZATION" shall mean the resumption of work with all resources required for the work after demobilization.

2.2. LAW GOVERNING THE CONTRACT AND COURT JURISDICTION

Place:
Date:

Signature of Authorized Signatory
with seal & full address



Bharat Heavy Electricals Limited

(A Govt. of India Undertaking)

Power Plant Piping Unit, Thirumayam – 622 507, Tamil Nadu

Tender Notice

The contract shall be governed by the Laws of India. Subject to clause 2.21.1.1 of this contract, the Civil Court having original Civil Jurisdiction at Tiruchirappalli, shall alone have exclusive jurisdiction in regard to all matters in respect of the Contract.

2.3. ISSUE OF NOTICE

2.3.1. Service of notice to the Contractor

Any notice to be given to the Contractor under the terms of the contract shall be served by sending the same by **Email/ Registered Post/Speed Post to or leaving the same at** the Contractor's last known address of the principal place of business (or in the event of the contractor being a company, to or at its Registered Office). In case of change of address, the notice shall be served at changed address as notified in writing by the Contractor to BHEL. Such dispatch or display posting or leaving of the notice as the case may be shall be deemed to be good service of such notice and the time mentioned to the condition for doing any act after notice shall be reckoned from the date so mentioned in such notice.

2.3.2. Service of notice to on BHEL

Any notice to be given to BHEL In-charge of the Unit under the terms of the Contract shall be served by sending the same by Registered/AD or Speed post to BHEL address or changed address as notified in writing by BHEL to the Contractor.

2.4. USE OF LAND

No land belonging to BHEL or their Customer under temporary possession of BHEL shall be occupied by the contractor without written permission of BHEL.

2.5. COMMENCEMENT OF WORK

2.5.1. The contractor shall commence the work as per the time indicated in the Letter of Intent/Award from BHEL and shall proceed with the same with due expedition without delay.

2.5.2. If the contractor fails to start the work within stipulated time as per LOI/ LOA or as intimated by BHEL, then BHEL at its sole discretion shall have the right to cancel the contract. The Earnest Money and/or Security Deposit furnished by the contractor to under this tender will stand forfeited without any further reference to him and without prejudice to BHEL's other rights and remedies under this contract and the applicable laws in this regard.

2.5.3. All the work shall be carried out under the direction and to the satisfaction of BHEL.

2.6. MEASUREMENT OF WORK AND MODE OF PAYMENT:

2.6.1. All payments due to the contractors shall be made by e mode only, unless otherwise found operationally difficult for reasons to be recorded in writing

2.6.2. For progress running bill payments: - The Contractor shall present detailed measurement sheets in triplicate, duly indicating all relevant details based on technical documents and connected drawings for work done during the month/period under various categories in line with terms of payment as per contract. The basis of arriving at the quantities, weights shall be relevant documents and drawings released by BHEL. These measurement sheets shall be prepared jointly with BHEL Engineers and signed by both the parties.

Place:
Date:

Signature of Authorized Signatory
with seal & full address



Bharat Heavy Electricals Limited

(A Govt. of India Undertaking)

Power Plant Piping Unit, Thirumayam – 622 507, Tamil Nadu

Tender Notice

- 2.6.3. These measurement sheets will be checked by BHEL Engineer and quantities and percentage eligible for payment under various groups shall be decided by BHEL Engineer. The abstract of quantities and percentage so arrived at based on the terms of payment shall be entered in Measurement Book and signed by both the parties.
- 2.6.4. Based on the above quantities, contractor shall prepare the bills, along with statutory documents, in prescribed format and work out the financial value. These will be entered in Measurement Book and signed by both the parties. Payment shall be made by BHEL after effecting the recoveries due from the contractor.
- 2.6.5. All recoveries due from the contractor for the month/period shall be effected in full from the corresponding running bills unless specific approval from the competent authorities is obtained to the contrary.
- 2.6.6. Measurement shall be restricted to that portion of work for which it is required to ascertain the financial liability of BHEL under this contract.
- 2.6.7. The measurement shall be taken jointly by persons authorized on the part of BHEL and by the Contractor.
- 2.6.8. The Contractor shall bear the expenditure involved if any, in making the measurements and testing of materials to be used/ used in the work. The contractor shall, without extra charges, provide all the assistance with appliances and other things necessary for measurement.
- 2.6.9. If at any time due to any reason whatsoever, it becomes necessary to re-measure the work done in full or in part, the expenses towards such re measurements shall be borne by the contractor unless such re measurements are warranted solely for reasons not attributable to contractor.
- 2.6.10. Passing of bills covered by such measurements does not amount to acceptance of the completion of the work measured. Any left out work has to be completed, if pointed out at a later date by BHEL.

Final measurement bill shall be prepared in the final bill format prescribed for the purpose based on the certificate issued by BHEL Engineer that entire works as stipulated in tender specification has been completed in all respects to the entire satisfaction of BHEL. The Contractor shall submit the final bill in line with WAM 7 format as per tender documents with an additional recording of the dispute, if any and shall sign with the following declaration:

I/ We hereby certify that I/We have performed the work as per the terms and conditions of Contract Agreement/Work Order No..... dated.....for which payment is claimed as above and that I/We have no further claim under this agreement/work order* except for the following (nature of claim with details & amount claimed, if any. NIL may be mentioned if there are no further claims). –

- a)
- b)
- c)

Place:
Date:

Signature of Authorized Signatory
with seal & full address



Bharat Heavy Electricals Limited

(A Govt. of India Undertaking)

Power Plant Piping Unit, Thirumayam – 622 507, Tamil Nadu

Tender Notice

It is agreed that the authorized signatory of Contractor shall necessarily record his claims/ dispute in Form WAM 7 only and any claim(s)/ dispute in any other form/ letter shall not be taken cognizance of by BHEL and admissible before any forum. BHEL shall make the payment of undisputed amount within the stipulated time without any unreasonable delay.

All the tools and tackles loaned to him should be returned in satisfactory condition to BHEL. The abstract of final quantities and financial values shall also be entered in the Measurement Books and signed by both parties to the contract. The Final Bill shall be prepared and paid within a reasonable time after completion of work.

2.7. RIGHTS OF BHEL

BHEL reserves the following rights in respect of this contract during the original contract period or its extensions if any, as per the provisions of the contract, without entitling the contractor for any compensation.

2.7.1. To withdraw any portion of work and/or to restrict/alter quantum of work as indicated in the contract during the progress of work and get it done through other agencies to fulfil BHEL's commitment to its customer or the date of completion is advance due to other emergent reasons/ BHEL's obligation to its customer.

In case of inadequate manpower deployed by the, BHEL reserves the right to deploy manpower to meet such shortfall, through any other agency for expediting activities in the interest of the project. Supplied manpower shall be put on job by the contractor and payments and other statutory compliances related to such manpower shall be the contractor's responsibility. In case of contractor's failure to fulfill his obligations in respect of such manpower, BHEL reserves the right to take necessary action as per contract conditions.

2.7.2 BREACH OF CONTRACT, REMEDIES AND TERMINATION

BHEL shall notify the contractor by way of 14 days' notice to rectify/improve the breaches mentioned herein within the time prescribed in the said notice. If the contractor fails to rectify/improve the breaches with the stipulated time period, then terms of the contract shall be considered to have been breached. In that Case BHEL shall have the right to terminate the contract in any of the following breaches:

- i) Contractor's poor progress of the work vis-à-vis execution timeline as stipulated in the Contract, backlog attributable to contractor including unexecuted portion of work does not appear to be executable within balance available period considering its performance of execution.
- ii) Withdrawal from or abandonment of the work by contractor before completion of the work as per contract.
- iii) Non-completion of work by the Contractor within scheduled completion period as per Contract or as extended from time to time, for the reasons attributable to the contractor.

Place:
Date:

Signature of Authorized Signatory
with seal & full address



Bharat Heavy Electricals Limited

(A Govt. of India Undertaking)

Power Plant Piping Unit, Thirumayam – 622 507, Tamil Nadu

Tender Notice

- iv) Repeated failure of contractor in deploying the required resources, to comply the statutory requirements etc. even after given by BHEL in writing.
- v) Strike or Lockout declared is not settled within a period of one month.
- vi) Termination of Contract on account of any other reason (s) attributable to Contractor.
- vii) Assignment, transfer, subletting of Contract without BHEL's written permission.
- viii) Non-compliance to any contractual condition or any other default attributable to Contractor.

LD against delay in executed work in case of Termination of Contract:

LD against delay in executed work shall be calculated in line with LD clause no. 2.7.9 of GCC, for the delay attributable to contractor. For limiting the maximum value of LD, contract value shall be taken as Executed Value of work till termination of contract.

Method for calculation of "LD against delay in executed work in case of termination of contract" is given below.

- i. Let the time period from scheduled date of start of work till termination of contract excluding the period of Hold (if any) not attributable to contractor = T1
- ii. Let the value of executed work till the time of termination of contract = X
- iii. Let the Total Executable Value of work for which inputs/fronts were made available to contractor and were planned for execution till termination of contract = Y
- iv. Delay in executed work attributable to contractor i.e. $T2 = [1 - (X/Y)] \times T1$
- v. LD shall be calculated in line with LD clause (clause 2.7.9) of the Contract for the delay attributable to contractor taking "X" as Contract Value and "T2" as period of delay attributable to contractor.

2.7.2.1 Remedies in case of Breach of Contract.

- i. Wherein the period as stipulated in the notice issued under clause 14.1 has expired and Contractor has failed to remedy the breach, BHEL will have the right to terminate the contract on the ground of "Breach of Contract" without any further notice to contractor.
- ii. Upon termination of contract, BHEL shall be entitled to recover an amount equivalent to 10% of the Contract Value for the damages on account of breach of contract committed by the Contractor. This amount shall be recovered by way of encashing the security instruments like performance bank guarantee etc available with BHEL against the said contract. In case the value of the security instruments available is less than 10% of the contract value, the balance amount shall be recovered from other financial remedies (i.e. available bills of the contractor, retention amount, from the money due to the Contractor etc. with BHEL) or the other legal remedies shall be pursued.
- iii. wherever the value of security instruments like performance bank guarantee available with BHEL against the said contract is 10% of the contract value or more, such security instruments to the extent of 10% contract value will be encashed. In case no security instruments are available or the value of the security instruments available is less than 10%

Place:
Date:

Signature of Authorized Signatory
with seal & full address



Bharat Heavy Electricals Limited

(A Govt. of India Undertaking)

Power Plant Piping Unit, Thirumayam – 622 507, Tamil Nadu

Tender Notice

of the contract value, the 10% of the contract value or the balance amount, as the case may be, will be recovered in all or any of the following manners:

- iv. In case the amount recovered under sub clause (a) above is not sufficient to fulfil the amount recoverable then; a demand notice to deposit the balance amount within 30 days shall be issued to Contractor.
- v. If Contractor fails to deposit the balance amount within the period as prescribed in demand notice, following action shall be taken for recovery of the balance amount:
 - a. from dues available in the form of Bills payable to defaulted Contractor against the same contract.
 - b. If it is not possible to recover the dues available from the same contract or dues are insufficient to meet the recoverable amount, balance amount shall be recovered from any money(s) payable to Contractor under any contract with other Units of BHEL including recovery from security deposits or any other deposit available in the form of security instruments of any kind against Security deposit or EMD.
 - c. In-case recoveries are not possible with any of the above available options, Legal action shall be initiated for recovery against defaulted Contractor.
- vi. It is an agreed term of contract that this amount shall be a genuine pre-estimate of damages that BHEL would incur in completion of balance contractual obligation of the contract through any other agency and BHEL will not be required to furnish any other evidence to the Contractor for the purpose of estimation of damages.
- vii. In addition to the above, imposition of liquidated damages, debarment, termination, de-scoping, short-closure, etc., shall be applied as per provisions of the contract.

Note:

- 1) The defaulting contractor shall not be eligible for participation in any of the future enquiries floated by BHEL to complete the balance work. The defaulting contractor shall mean and include:
 - (a) In case defaulted contractor is the Sole Proprietorship Firm, any Sole Proprietorship Firm owned by same Sole Proprietor.
 - (b) In case defaulted contractor is The Partnership Firm, any firm comprising of same partners/ some of the same partners (but not including any new partner); or sole proprietorship firm owned by any partner(s) as a sole proprietor.
- 2.7.2. In case Contractor fails to deploy the resources as per requirement informed by BHEL in writing to expedite the work, BHEL can deploy own/hired/otherwise arranged resources and recover the expenses incurred from the dues payable to contractor. Recoveries shall be actual expenses incurred plus 5% overheads or as defined in TCC.
- 2.7.3. To terminate the contract or to restrict the quantum of work and pay for the portion of work executed in case BHEL's contract with their customer are terminated for any reason, whatsoever.

Place:
Date:

Signature of Authorized Signatory
with seal & full address



Bharat Heavy Electricals Limited

(A Govt. of India Undertaking)

Power Plant Piping Unit, Thirumayam – 622 507, Tamil Nadu

Tender Notice

2.7.4. Whenever any Claim or Claims for payment of any sum of money(s) arises under this or any other contract against the contractor, BHEL shall be entitled to withhold and also have a lien to retain such sum of money(s) in whole or in part from any money(s) payable to contractor and/or security deposits furnished or deducted in cash from the bills of contractor, (if any) under this contract. In the event of the securities or the amounts payable to Contractor, being insufficient to cover BHEL claims, then BHEL shall be entitled to withhold and have a lien to the extent of such claims from any sum or sums found payable or which at any time thereafter may become payable to the contractor under this or any other contract with BHEL.

- a) Claim or Claims for payment of any sum of money(s) arising from the Contractor under this or any other contract against the contractor, shall mean, the sum of money(s) actually incurred by BHEL in fulfilling the contractual responsibilities of contractor under the contract, to which he has failed to fulfil plus applicable overheads (@ 5%) along with interest as applicable under the Contract on total amount (i.e. money actually incurred plus overheads)
- b) It is an agreed term of the contract that, the sum or sums of money so withheld or retained under the lien by BHEL will be kept withheld or retained as such by BHEL till the claims arising out of this or any other contract are finally adjudicated wither through Arbitration or a Court of competent jurisdiction as the case may be in accordance with the terms of contract. Intimation given by the BHEL Engineer regarding withholding of such money(s) shall be considered as sufficient and relevant date for all purposes. No Interest shall be payable on such sum(s) of money which becomes due or as the case may be adjudged to be due from BHEL to Contractor, whether under contract or otherwise.
- c) Where the contractor is a partnership firm, BHEL shall be entitled to withhold and also have a lien to retain towards such claims in whole or in part, from any other money(s) payable to any partner, whether in his individual capacity or otherwise.
- d) If any money(s) shall, as a result of any claim or application made under the relevant provisions of any Labour Welfare Act and/ or Rules, including but not limited to Contract Labour Regulation & Abolition Act, Minimum Wages Act, Payment of Gratuity Act, BOCW (RE&CS) Act, Provident Fund Act, Employee State Insurance Act, be directed to be paid by the BHEL, such money shall be deemed to be moneys payable to the BHEL by the Contractor.
- e) Where the Contractor fails to repay to BHEL such moneys along with applicable overheads (@ 5%) and interest, as aforesaid within seven days of being demanded, BHEL shall be entitled to recover the same from Contractor's bills/ Security Deposit or any other money(s) payable to Contractor under this Contract or any other Contract with BHEL.

2.7.5. While every endeavor will be made by BHEL to this end, yet BHEL cannot guarantee uninterrupted work due to conditions beyond its control. The Contractor will not be normally entitled for any

Place:
Date:

Signature of Authorized Signatory
with seal & full address



Bharat Heavy Electricals Limited

(A Govt. of India Undertaking)

Power Plant Piping Unit, Thirumayam – 622 507, Tamil Nadu

Tender Notice

compensation/extra payment on this account unless otherwise specified elsewhere in the contract.

2.7.6. BHEL may permit or direct contractor to demobilize and remobilize at a future date as intimated by BHEL in case of following situations for reasons other than Force majeure conditions and not attributable to contractor:

- i. suspension of work(s) at a Project either by BHEL or Customer,
or
- ii. where work comes to a complete halt or reaches a stage wherein worthwhile works cannot be executed and there is no possibility of commencement of work for a period of not less than three months

In such cases, charges towards demobilization and remobilization shall be as decided by BHEL after successful remobilization by contractor at site, and decision of BHEL shall be final and binding on the contractor. After remobilization, all conditions as per contract shall become applicable. In case Contractor does not remobilize with adequate resources or does not start the work within the period as intimated, then BHEL reserves the right to terminate the contract and effect remedies under Clause 2.7.2.1. In case of any conflict, BHEL decision in this regard shall be final and binding on the contractor.

2.7.7. In the unforeseen event of inordinate delay in receipt of materials, drawings, fronts etc. due to which inordinate discontinuity of work is anticipated, BHEL on its own or contractor's request at its discretion may consider to short close the contract in any of the following cases:

- a) The balance works (including but not limited to Trial Operation, PG Test etc.) are minor vis a vis the scope of work envisaged as per the contract.
- b) There has been no significant work in past 6 months OR no significant work is expected in next 6 months (example in Hydro projects or in projects where work has stopped due to reasons beyond the control of BHEL).
- c) The balance works cannot be done within a reasonable period of time as they are dependent on unit shut down or on other facilities of customer or any other such reasons not attributable to the contractor.

At the point of requesting for short closure, contractor shall establish that he has completed all works possible of completion and he is not able to proceed with the balance works due to constraints beyond his control. In such a case, the estimated value of the unexecuted portion of work (or estimated value of services to be provided for carrying out milestone/stage payments like Trial Operation/PG Test etc.) as decided by BHEL, shall however be reduced from the final contract value.

Note: The Contractor shall not be eligible for any compensation on account of Quantity Variation arising out of short-closure of contract as per clause no. 2.7.8 (b) above.

2.7.8. **LIQUIDATED DAMAGES**

Place:
Date:

Signature of Authorized Signatory
with seal & full address



Bharat Heavy Electricals Limited

(A Govt. of India Undertaking)

Power Plant Piping Unit, Thirumayam – 622 507, Tamil Nadu

Tender Notice

Liquidated Damages, wherever referred under this Tender/Agreement, shall mean and refer to the damages, not in the nature of penalty, which the contractor agrees to pay in the event of delay in delivery of stores, installation, commissioning, breach of contract etc. as the case may be.

Liquidated Damages leviable upon the contractor is a sum which is agreed by the parties as a reasonable and genuine pre-estimate of damages which will be suffered by BHEL on account of delay/breach on the part of the contractor.

Liquidated Damages shall be calculated in the manner stipulated hereinafter:

In case the work is not completed within the stipulated time period, BHEL at its discretion may grant provisional time extension to contractor for the sole purpose of completion of balance works keeping its right reserved under the contract and law.

Grant of any provisional time extension shall by no means be considered as waiver of BHEL rights under the contract or law.

After the completion of work, duly certified by Engineer Incharge, a comprehensive delay analysis shall be carried out to ascertain the attribution of delays in the provisional time extensions granted to contractor. The delay analysis shall record:

- a) Delays solely attributable to contractor
- b) Delays attributable to BHEL
- c) Delays on account of Force Majeure (as specified elsewhere in the contract)

The total period under the final time extension shall be equal to the period between the scheduled date of completion and the actual date of completion of contract. LD shall be imposed/ levied for the portion of time

extensions solely attributable to contractor and recoverable from the dues payable to the contractor.

For the periods, wherein the delay as per the comprehensive delay analysis carried out is solely attributable to contractor, BHEL shall have the right to impose Liquidated Damage at the rate of 0.5% of the contract value, per week of delay or part thereof subject to a maximum of 10% of the contract value.

Contract Value for this purpose, shall be the final executed value exclusive of ORC, Extra Works executed on Man-day rate basis, Supplementary/ Additional Items and PVC. Before levying LD, the contractor shall be duly intimated the amount and reasons thereof for imposition of LD.

- 2.7.9 If at any time after the award of contract, BHEL shall for any reason whatsoever not require whole or any part of the work to be carried out, the HOD/Contracts Dept. or his authorized representative, shall give notice in writing of the fact to the Contractor who shall have no claim to any payment of compensation or otherwise howsoever on account of any profit or advantage which he might have derived from the execution of the work in full but which he did not derive in consequence of the fore-closing of the work.

Place:
Date:

Signature of Authorized Signatory
with seal & full address



Bharat Heavy Electricals Limited

(A Govt. of India Undertaking)

Power Plant Piping Unit, Thirumayam – 622 507, Tamil Nadu

Tender Notice

2.8. RESPONSIBILITIES OF THE CONTRACTOR IN RESPECT OF LOCAL LAWS, EMPLOYMENT OF WORKERS ETC.

The following are the responsibilities of the contractor in respect of observance of local laws, employment of personnel, payment of taxes etc. The subcontractor shall fully indemnify BHEL against any claims of whatsoever nature arising due to the failure of the contractor in discharging any of his responsibilities hereunder:

- 2.8.2. As far as possible, Unskilled Workers shall be engaged from the local areas in which the work is being executed.
- 2.8.3. The contractor at all times during the continuance of this contract shall, in all his dealings with local labour for the time being employed on or in connection with the work, have due regard to all local festivals and religious and other customs.
- 2.8.4. The contractor shall comply with all applicable State and Central Laws, Statutory Rules, Regulations, Notifications etc. such as Payment of Wages Act, Minimum Wages Act, Workmen Compensation Act, Employer's Liability Act, Industrial Disputes Act, Employers Provident Fund and Miscellaneous Provisions Act, 1952, Employees State Insurance Scheme, Contract Labour (Regulation and Abolition) Act, 1970, Payment of Bonus & Gratuity Act, Building and Other Construction Workers (Regulation of Employment and Conditions of Service) Act 1996, The Building and Other Construction Workers' Welfare Cess Act 1996 and other Acts, Rules, and Regulations for labour/workers as applicable and as may be enacted by the State Government and Central Govt. during the tenure of the Contract and having force or jurisdiction at Site. The Contractor shall also comply with provisions of and give all such notices to the local Governing Body, Police and other relevant Authorities as may be required by the Law.
- 2.8.5. The Contractor shall obtain independent License under the Contract Labour (Regulations and Abolition) Act, 1970 for engaging contract labour as required from the concerned Authorities based on the certificate (Form- V or as applicable) issued by the Principal Employer/Customer.
- 2.8.6. The contractor shall pay and bear all taxes, fees, license charges, Cess, duties, deposits, tolls, royalties, commission or other charges which may be leviable on account of his operations in executing the contract.
- 2.8.7. While BHEL would pay the inspection fees and Registration fees of Boiler/Electrical Inspectorate, all other arrangements for site visits periodically by the Inspectorate to site, Inspection certificate etc. will have to be made by contractor. However, BHEL will not make any payment to the Inspectorate in connection with contractor's Welders/Electricians qualification tests etc.
- 2.8.8. Contractor shall be responsible for provision of Health and Sanitary arrangements (more particularly described in Contract Labour Regulation & Abolition Act), Safety precautions etc. as may be required for safe and satisfactory execution of contract.
- 2.8.9. The contractor shall be responsible for proper accommodation including adequate medical facilities for personnel employed by him.

Place:
Date:

Signature of Authorized Signatory
with seal & full address



Bharat Heavy Electricals Limited

(A Govt. of India Undertaking)

Power Plant Piping Unit, Thirumayam – 622 507, Tamil Nadu

Tender Notice

- 2.8.10. The contractor shall be responsible for the proper behaviour and observance of all regulations by the staff employed by him.
- 2.8.11. The contractor shall ensure that no damage is caused to any person/property of other parties working at site/company” premises. If any such damage is caused, it is responsibility of the contractor to make good the losses or compensate for the same.
- 2.8.12. All the properties/equipments/components of BHEL/their Client loaned with or without deposit to the contractor in connection with the contract shall remain properties of BHEL/their Client
- 2.8.13. The contractor shall use such properties for the purpose of execution of this contract. All such properties/equipments/components shall be deemed to be in good condition when received by the contractor unless he notifies within 48 hours to the contrary. The contractor shall return them in good condition as and when required by BHEL/their Client. In case of non-return, loss, damage, repairs etc. the cost thereof as may be fixed by BHEL Engineer will be recovered from the contractor.
- 2.8.14. In case the contractor is required to undertake any work outside the scope of this contract, the rates payable shall be those mutually agreed upon if the item rates are not mentioned in existing contract.
- 2.8.15. Any delay in completion of works/or non-achievement of periodical targets/or non-execution of contract due to the reasons attributable to the contractor, the same may have to be compensated by the contractor either by increasing manpower and resources or by working extra hours and/or by working more than one shift. All these are to be carried out by the contractor at no extra cost.
- 2.8.16. The contractor shall arrange, coordinate his work in such a manner as to cause no hindrance to other agencies working in the same premises.
- 2.8.17. All safety rules and codes applied by the Customer /BHEL at site shall be observed by the contractor without exception. The contractor shall be responsible for the safety of the equipment/material and works to be performed by him and shall maintain all light, fencing guards, slings etc. or other protection necessary for the purpose. Contractor shall also take such additional precautions as may be indicated from time to time by the Engineer with a view to prevent pilferage, accidents, fire hazards. Due precautions shall be taken against fire hazards and atmospheric conditions. Suitable number of Clerical staff, watch and ward, store keepers to take care of equipment/materials and construction tools and tackles shall be posted at site by the contractor till the completion of work under this contract.

The contractor shall arrange for such safety devices as are necessary for such type of work and carry out the requisite site tests of handling equipment, lifting tools, tackles etc. as per prescribed standards and practices.

Contractor has to ensure the implementation of Health, Safety and Environment (HSE) requirements as per directions given by BHEL/Customer. The contractor has to assist in HSE audit by BHEL/Customer and submit compliance Report. The contractor has to generate and submit record/reports as per HSE plan/activities as per instruction of BHEL/Customer.

Place:
Date:

Signature of Authorized Signatory
with seal & full address



Bharat Heavy Electricals Limited

(A Govt. of India Undertaking)

Power Plant Piping Unit, Thirumayam – 622 507, Tamil Nadu

Tender Notice

2.8.18. The contractor shall be directly responsible for payment of wages to his workmen/labours before the expiry of seven days from the last day of wage period and to ensure disbursement of wages in the presence of the representative from BHEL A pay roll sheet giving all the payments given to the workers and duly signed by the contractor's representative should be furnished to BHEL site for the purpose of maintaining the records for compliance,

Contractor shall create awareness amongst their workforce by helping & encouraging in opening bank accounts and to encourage them to adopt digital mode of transactions. While releasing wages/ salary to their workers/ supervisors/ staff, Contractor shall comply with the GOI's guidelines for maximizing such transactions through Non-Cash / digital means.

2.8.19. In case of any class of work for which there is no such specification as laid down in the contract, such work shall be carried out in accordance with the instructions and requirements of the Engineer.

2.8.20. Also, no idle charges will be admissible in the event of any stoppage caused in the work resulting in contractor's labour and Tools & Plants being rendered idle due to any reason at any time.

2.8.21. The contractor shall take all reasonable care to protect the materials and work till such time the plant/equipment has been taken over by BHEL or their Customer whichever is earlier.

2.8.22. The contractor shall not stop the work or abandon the site for whatsoever reason of dispute, excepting force majeure conditions. All such problems/disputes shall be separately discussed and settled without affecting the progress of work. Such stoppage or abandonment shall be treated as breach of contract and dealt with accordingly.

2.8.23. The contractor shall keep the area of work clean and shall remove the debris etc. while executing day-to-day work. Upon completion of work, the contractor shall remove from the vicinity of work, all scrap, packing materials, rubbish, unused and other materials and deposit them in places specified by the Engineer. The contractor will also demolish all the hutments, sheds, offices etc. constructed and used by him and shall clean the debris. In the event of his failure to do so, the same will be arranged to be done by the Engineer and the expenses recovered from the contractor.

2.8.24. The contractor shall execute the work in the most substantial and workman like manner in the stipulated time. Accuracy of work and timely execution shall be the essence of this contract. The contractor shall be responsible to ensure that the quality, assembly and workmanship conform to the dimensions and clearance given in the drawings and/ or as per the instructions of the Engineer.

2.8.25. The Contractor to note that some of BHEL's T&Ps/MMDs may not be insured. The Contractor will take necessary precautions and due care to protect the same while in his custody from any damage/ loss till the same is handed over back to BHEL. In case the damage / loss is caused due to carelessness/ negligence on the part of the contractor, the Contractor is liable to get them repair/ replaced immediately and in case of his failure to do so within a reasonable time, BHEL shall recover the loss from the contractor.

Place:
Date:

Signature of Authorized Signatory
with seal & full address



Bharat Heavy Electricals Limited

(A Govt. of India Undertaking)

Power Plant Piping Unit, Thirumayam – 622 507, Tamil Nadu

Tender Notice

2.8.26. For all works having contract value of Rs. 5,00,000/- or above, BHEL shall recover the amount of compensation paid to victim(s) by BHEL towards loss of life/ permanent disability due to an accident which is attributable to the negligence of contractor, agency or firm or any of its employees as detailed below.

- a) Victim: Any person who suffers permanent disablement or dies in an accident as defined below.
- b) Accident: Any death or permanent disability resulting solely and directly from any unintended and unforeseen injurious occurrence caused during the manufacturing/ operation and works incidental thereto at BHEL factories/ offices and precincts thereof, project execution, erection and commissioning, services, repairs and maintenance, trouble shooting, serving, overhaul, renovation and retrofitting, trial operation, performance guarantee testing undertaken by the company or during any works/ during working at BHEL Units/ Offices/ townships and premises/ Project Sites.
- c) Compensation in respect of each of the victims:
 - i. In the event of death or permanent disability resulting from Loss of both limbs: Rs. 10,00,000/- (Rs. Ten Lakh).
 - ii. In the event of other permanent disability: Rs.7,00,000/- (Rs. Seven Lakh)
- d) Permanent Disablement: A disablement that is classified as a permanent total disablement under the proviso to section 2 (l) of the Employee's Compensation Act, 1923.

2.8.27. Contractor shall be fully responsible for the safety of their T&Ps and other material mobilized at site. In any case, BHEL shall not be liable for any damage/loss/misuse of any item(s) belong to the contractor.

2.8.28. Contractor will ensure that the work/job is executed through his/her employees on and under no circumstances, the contractor shall subcontract the job without prior written permission from BHEL.

2.8.29. The liability for any compensation on account of injury sustained by an employee of the contractor will be exclusively that of the contractor.

2.9. EXECUTION PLAN, PROGRESS MONITORING, MONTHLY REVIEW AND PERFORMANCE EVALUATION

2.9.2. A tentative plan/ programme for completion of the contractual scope of work as per the time schedule given in the contract shall be made jointly by BHEL and Contractor, before commencement of work. The above programme shall be supported by month wise deployment of resources viz Manpower, T&P, Consumables, etc. Progress will be reviewed periodically (Daily/Weekly/Monthly) vis-à-vis this jointly agreed programme.

Subsequently, every month, quarterly rolling plan will be made by BHEL based on budgeted targets.

Place:
Date:

Signature of Authorized Signatory
with seal & full address



Bharat Heavy Electricals Limited

(A Govt. of India Undertaking)

Power Plant Piping Unit, Thirumayam – 622 507, Tamil Nadu

Tender Notice

Monthly plan in F-14 format shall be drawn from this Quarterly plan. Monthly plan shall necessarily include activities required for achieving targets/ milestones unless inputs/ fronts are not available. While planning and arriving on asking rate all available inputs shall be taken into consideration. Vendor will be required to execute the monthly plan in that month in addition to make full efforts to minimize the cumulative shortfall attributable to him up to the month.

BHEL may require monthly work plan up to one and half times of average monthly value and demand matching manpower.

Where, Average Monthly Value = Total Contract Value (as per latest revision) / Period of Contract (in months)

Provided, this requirement is reflected in the rolling quarterly plan two months in advance.

If the Contractor refuses to sign the F-14 format, those F-14 formats requiring Contractor's signature shall be deemed to have been signed and accepted by the Contractor, if communicated to the Contractor through email or any other mode as stated in clause 2.3.1.

The Contractor shall submit periodical progress reports (Daily/Weekly/Monthly) and other reports/information including manpower, consumables, T&P mobilization etc. as desired by BHEL.

2.9.3. Monthly progress review between BHEL and Contractor shall be based on the agreed programme as above, availability of inputs/fronts etc., and constraints if any, as per prescribed formats (i.e. Form F-14). Manpower, T&P and consumable reports as per prescribed formats shall be submitted by contractor every month. Release of RA Bills shall be contingent upon certification by BHEL Site Engineer of the availability of the above prescribed formats duly filled in and signed.

2.9.4. The burden of proof that the causes leading to any shortfall is not due to any reasons attributable to the contractor is on the contractor himself. The monthly progress review shall record shortfalls attributable to (i) Contractor, (ii) Force Majeure Conditions, and (iii) BHEL

2.9.5. Performance of the Contractor shall be assessed as per prescribed formats and shall form the basis for 'Assessment of Capacity of Bidder' for Tenders where the Contractor is a bidder. BHEL reserves the right to revise the evaluation formats during the course of execution of the works.

2.10. TIME OF COMPLETION

2.10.2. The time for completion shall be as mentioned in the LOA/Contract. The time for completion shall be reckoned from the date of commencement of work at Site as certified/notified in writing by BHEL Engineers.

2.10.3. Time being the essence of the contract, the entire work shall be completed by the contractor within the time schedule or within such extended periods of time as may be allowed by BHEL under clause 2.11.

2.11. EXTENSION OF TIME FOR COMPLETION

2.11.2. If the completion of work as detailed in the scope of work gets delayed beyond the contract period, the contractor shall request for an extension of the contract and BHEL at its discretion may extend the Contract. If the completion of work gets delayed for reasons not attributable to the contractor, the contract period may be suitably extended at the sole discretion of BHEL.

Place:
Date:

Signature of Authorized Signatory
with seal & full address



Bharat Heavy Electricals Limited

(A Govt. of India Undertaking)

Power Plant Piping Unit, Thirumayam – 622 507, Tamil Nadu

Tender Notice

2.11.3. Based on the F-14 formats, the works balance at the end of original contract period less the backlog attributable to the contractor shall be quantified, and the number of months of 'Time extension' required for completion of the same shall be jointly worked out. Within this period of 'Time extension', the contractor is bound to complete the portion of backlog attributable to the contractor. Any further 'Time extension' or 'Time extensions' at the end of the previous extension shall be worked out similarly.

2.11.4. However, if any 'Time extension' is granted to the contractor to facilitate continuation of work and completion of contract, due to backlog attributable to the contractor alone, then it shall be without prejudice to the rights of BHEL to impose penalty/LD for the delays attributable to the contractor, in addition to any other actions BHEL may wish to take under Clause 2.7.2 of GCC i.e. Breach of Contract, Remedies and Termination.

2.11.5. Planning, progress monitoring, monthly review and performance monitoring shall be carried out as per clause 2.9 of GCC.

2.12. **INSURANCE**

2.12.2. BHEL/their customer shall arrange for insuring the materials/properties of BHEL/customer covering the risks during transit, storage, erection and commissioning.

2.12.3. It is the sole responsibility of the contractor to insure his materials, equipment, workmen etc. against accidents and injury while at work and to pay compensation, if any, to workmen as per Workmen's compensation Act. The work will be carried out in a protected area and all the rules and regulations of the client /BHEL in the area of project which are in force from time to time will have to be followed by the contractor.

2.12.4. If due to negligence and or non-observation of safety and other precautions by the contractors, any accident/injury occurs to the property / manpower belong to third party, the contractor shall have to pay necessary compensation and other expense, if so decided by the appropriate authorities.

2.12.5. The contractor will take necessary precautions and due care to protect the material, while in his custody from any damage/ loss due to theft or otherwise till the same is taken over by BHEL or customer. For lodging / processing of insurance claim, the contractor will submit necessary documents. BHEL will recover the loss including the deductible franchise from the contractor, in case the damage / loss is due to carelessness / negligence on the part of the contractor. In case of any theft of material under contractor's custody, matter shall be reported to Police by the contractor immediately and copy of FIR and subsequently police investigation report shall be submitted to BHEL for taking up with insurance. However, this will not relieve the contractor of his contractual obligation for the material in his custody.

2.13. **STRIKES & LOCKOUT**

2.13.2. The contractor will be fully responsible for all disputes and other issues connected with his labour. In the event of the contractor's labour resorting to strike or the Contractor resorting to lockout and if the strike or lockout declared is not settled within a period of one month, it may be

Place:

Date:

Signature of Authorized Signatory
with seal & full address



Bharat Heavy Electricals Limited

(A Govt. of India Undertaking)

Power Plant Piping Unit, Thirumayam – 622 507, Tamil Nadu

Tender Notice

considered as 'Breach of Contract' under Clause 2.7 and the remedies under Clause 2.7.2.1 may be executed, at the discretion of BHEL.

For all purposes whatsoever, the employees of the contractor shall not be deemed to be in the employment of BHEL.

2.14. **FORCE MAJEURE**

2.14.2. "Force Majeure" shall mean circumstance which is:

- a) beyond control of either of the parties to contract,
- b) either of the parties could not reasonably have provided against the event before entering into the contract,
- c) having arisen, either of the parties could not reasonably have avoided or overcome, and
- d) is not substantially attributable to either of the parties

And

Prevents the performance of the contract,

Such circumstances include but shall not be limited to:

- i. War, hostilities, invasion, act of foreign enemies.
- ii. Rebellion, terrorism, revolution, insurrection, military or usurped power, or civil war.
- iii. Riot, commotion or disorder by persons other than the contractor's personnel and other employees of the contractor and sub-contractors.
- iv. Strike or lockout not solely involving the contractor's personnel and other employees of the contractor and sub-contractors.
- v. Encountering munitions of war, explosive materials, ionizing radiation or contamination by radio-activity, except as may be attributable to the contractor's use of such munitions, explosives, radiation or radio- activity.
- vi. Natural catastrophes such as earthquake, tsunami, volcanic activity, hurricane or typhoon, flood, fire, cyclones etc.
- vii. Epidemic, pandemic etc.

2.14.3. The following events are explicitly excluded from Force Majeure and are solely the responsibilities of the non-performing party: a) any strike, work-to-rule action, go-slow or similar labour difficulty (b) late delivery of equipment or material (unless caused by Force Majeure event) and (c) economic hardship.

2.14.4. If either party is prevented, hindered or delayed from or in performing any of its obligations under the Contract by an event of Force Majeure, then it shall notify the other in writing of the occurrence of such event and the circumstances thereof within 15 (fifteen) days after the occurrence of such event.

2.14.5. The party who has given such notice shall be excused from the performance or punctual performance of its obligations under the Contract for so long as the relevant event of Force Majeure continues and to the extent that such party's performance is prevented, hindered or

Place:
Date:

Signature of Authorized Signatory
with seal & full address



Bharat Heavy Electricals Limited

(A Govt. of India Undertaking)

Power Plant Piping Unit, Thirumayam – 622 507, Tamil Nadu

Tender Notice

delayed. The Time for Completion shall be extended by a period of time equal to period of delay caused due to such Force Majeure event.

2.14.6. Delay or non-performance by either party hereto caused by the occurrence of any event of Force Majeure shall not

- a) Constitute a default or breach of the Contract.
- b) Give rise to any claim for damages or additional cost expense occasioned thereby, if and to the extent that such delay or non-performance is caused by the occurrence of an event of Force Majeure.

2.14.7. BHEL at its discretion may consider short closure of contract after 1 year of imposition of Force Majeure in line with extant guidelines. In any case, Supplier/Vendor cannot consider deemed short-closure after 1 year of imposition of Force Majeure

2.15. **Settlement of Dispute**

If any dispute or difference of any kind whatsoever shall arise between BHEL and the Supplier/Vendor, arising out of the contract for the performance of the work whether during the progress of contract termination, abandonment or breach of the contract, it shall in the first place referred to Designated Engineer for amicable resolution by the parties. Designated Engineer (to be nominated by BHEL for settlement of disputes arising out of the contract) who within 60 days after being requested shall give written notice of his decision to the contractor. Save as hereinafter provided, such decision in respect of every matter so referred shall forthwith be given effect to by the Supplier/Vendor who shall proceed with the work with all due diligence, whether he or BHEL desires to resolve the dispute as hereinafter provided or not.

If after the Designated Engineer has given written notice of this decision to the party and no intention to pursue the dispute has been communicated to him by the affected party within 30 days from the receipt of such notice, the said decision shall become final and binding on the parties. In the event the Supplier/Vendor being dissatisfied with any such decision or if amicable settlement cannot be reached then all such disputed issues shall be resolved through conciliation in terms of the BHEL Conciliation Scheme 2018 as per Clause 2.15.1

2.15.2. **CONCILIATION**

Any dispute, difference or controversy of whatever nature howsoever arising under or out of or in relation to this Agreement (including its interpretation) between the Parties, and so notified in writing by either Party to the other Party (the "Dispute") shall, in the first instance, be attempted to be resolved amicably in accordance with the conciliation procedure as per BHEL Conciliation Scheme 2018. The proceedings of Conciliation shall broadly be governed by Part-III of the Arbitration and Conciliation Act 1996 or any statutory modification thereof and as provided in - "Procedure for conduct of conciliation proceedings" (as available in www.bhel.com)).

2.15.3. **ARBITRATION:**

2.15.2.1. Except as provided elsewhere in this Contract, in case Parties are unable to reach amicable settlement (whether by Conciliation to be conducted as provided in Clause 14.1 herein above or

Place:
Date:

Signature of Authorized Signatory
with seal & full address



Bharat Heavy Electricals Limited

(A Govt. of India Undertaking)

Power Plant Piping Unit, Thirumayam – 622 507, Tamil Nadu

Tender Notice

otherwise) in respect of any dispute or difference; arising out of the formation, breach, termination, validity or execution of the Contract; or, the respective rights and liabilities of the Parties; or, in relation to interpretation of any provision of the Contract; or, in any manner touching upon the Contract (hereinafter referred to as the 'Dispute'), then, either Party may, refer the disputes to **Madras High Court, Arbitration Centre (MHCAC)** and such dispute to be adjudicated by Sole Arbitrator appointed in accordance with the Rules of said Arbitral Institution.

2.15.2.2. A party willing to commence arbitration proceeding shall invoke Arbitration Clause by giving notice to the other party in terms of section 21 of the Arbitration & Conciliation Act, 1996 (hereinafter referred to as the 'Notice') before referring the matter to arbitral institution. The Notice shall be addressed to the Head of the Unit, BHEL, executing the Contract and shall contain the particulars of all claims to be referred to arbitration with sufficient detail and shall also indicate the monetary amount of such claim including interest, if any.

2.15.2.3. After expiry of 30 days from the date of receipt of aforesaid notice, the party invoking the Arbitration shall submit that dispute to the Arbitral Institution- **Madras High Court, Arbitration Centre (MHCAC)**- and that dispute shall be adjudicated in accordance with their respective Arbitration Rules. The matter shall be adjudicated by a Sole Arbitrator who shall necessarily be a Retd Judge having considerable experience in commercial matters to be appointed/nominated by the respective institution. The cost/expenses pertaining to the said Arbitration shall also be governed in accordance with the Rules of the respective Arbitral Institution. The decision of the party invoking the Arbitration for reference of dispute to **Madras High Court, Arbitration Centre (MHCAC)**- for adjudication of that dispute shall be final and binding on both the parties and shall not be subject to any change thereafter. The institution once selected at the time of invocation of dispute shall remain unchanged.

2.15.2.4. The fee and expenses shall be borne by the parties as per the Arbitral Institutional rules.

2.15.2.5. The Arbitration proceedings shall be in English language and the seat of Arbitration shall be Trichy.

2.15.2.6. Subject to the above, the provisions of Arbitration & Conciliation Act 1996 and any amendment thereof shall be applicable. All matters relating to this Contract and arising out of invocation of Arbitration clause are subject to the exclusive jurisdiction of the Court(s) situated at **Trichy**.

2.15.2.7. Notwithstanding any reference to the Designated Engineer or Conciliation or Arbitration herein, a. the parties shall continue to perform their respective obligations under the Contract unless they otherwise agree. Settlement of Dispute clause cannot be invoked by the Contractor, if the Contract has been mutually closed or 'No Demand Certificate' has been furnished by the Contractor or any Settlement Agreement has been signed between the Employer and the Contractor.

2.15.2.8. It is agreed that Mechanism of resolution of disputes through arbitration shall be available only in the cases where the value of the dispute is less than Rs. 10 Crores.

Place:
Date:

Signature of Authorized Signatory
with seal & full address



Bharat Heavy Electricals Limited

(A Govt. of India Undertaking)

Power Plant Piping Unit, Thirumayam – 622 507, Tamil Nadu

Tender Notice

2.15.2.9. In case the disputed amount Claim, Counter claim including interest is Rs. 10 crores and above, the parties shall be within their rights to take recourse to remedies other than Arbitration, as may be available to them under the applicable laws after prior intimation to the other party. Subject to the aforesaid conditions, provisions of the Arbitration and Conciliation Act, 1996 and any statutory modifications or re-enactment thereof as amended from time to time, shall apply to the arbitration proceedings under this clause.

2.15.2.10. In case, multiple arbitrations are invoked (whether sub-judice or arbitral award passed) by any party to under this contract, then the cumulative value of claims (including interest claimed or awarded) in all such arbitrations shall be taken in account while arriving at the total claim in dispute for the subject contract for the purpose of clause 14.2.9. Disputes having cumulative value of less than 10 crores shall be resolved through arbitration and any additional dispute shall be adjudicated by the court of competent jurisdiction.

2.15.2.11. In case of Contract with Public Sector Enterprise (PSE) or a Government Department, the following shall be applicable:

In the event of any dispute or difference relating to the interpretation and application of the provisions of commercial contract(s) between Central Public Sector Enterprises (CPSEs)/ Port Trusts inter se and also between CPSEs and Government Departments/Organizations (excluding disputes concerning Railways, Income Tax, Customs & Excise Departments), such dispute or difference shall be taken up by either party for resolution through AMRCD (Administrative Mechanism for Resolution of CPSEs Disputes) as mentioned in DPE OM No. 05/0003/2019-FTS-10937 dated 14-12-2022 as amended from time to time.

2.15.4. NO INTEREST PAYABLE TO CONTRACTOR

Notwithstanding anything to the contrary contained in any other document comprising in the Contract, no interest shall be payable by BHEL to Contractor on any moneys or balances including but not limited to the Security Deposit, EMD, Retention Money, RA Bills or the Final Bill, or any amount withheld and/or appropriated by BHEL. etc., which becomes or as the case may be, is adjudged to be due from BHEL to Contractor whether under the Contract or otherwise.

2.15.5. Final Bill

Final Bill' is used for final payment on closing of Running Account for works or for single payment after completion of works. 'Final Bill' shall be submitted as per prescribed format after completion of works as per scope and upon material reconciliation, along with the following:

- i) 'No Claim Certificate' by Contractor
- ii) Clearance certificates where ever applicable viz. Clearance Certificates from Customer, various Statutory Authorities like Labour department, PF Authorities, Commercial Tax Department etc.
- iii) Indemnity Bond as per prescribed format.
- iv) BHEL shall settle the final bills after deducting all liabilities of Contractor to BHEL.

2.16. CLOSING OF CONTRACTS

Place:
Date:

Signature of Authorized Signatory
with seal & full address



Bharat Heavy Electricals Limited

(A Govt. of India Undertaking)

Power Plant Piping Unit, Thirumayam – 622 507, Tamil Nadu

Tender Notice

The Contract shall be considered completed and closed upon completion of contractual obligations and settlement of Final Bill or completion of Guarantee period whichever is later. Upon closing of Contract, BHEL shall issue a performance/ experience certificate as per standard format, based on specific request of Contractor as per extant BHEL guidelines through the online portal available at <https://suvidha.bhel.in> only.

2.17. **SUSPENSION OF BUSINESS DEALINGS**

BHEL reserves the right to take action against Contractors who either fail to perform or Tenderers/Contractor who indulge in malpractices, by suspending business dealings with them in line with BHEL guidelines issued from time to time.

The offers of the bidders who are under suspension as also the offers of the bidders, who engage the services of the banned firms / principal / agents, shall be rejected. The list of banned firms is available on BHEL web site www.bhel.com.

If any bidder / supplier / contractor during pre-tendering / tendering / post tendering / award / execution / post-execution stage indulges in any act, including but not limited to, mal-practices, cheating, bribery, fraud or and other misconduct or formation of cartel so as to influence the bidding process or influence the price or tampers the tendering process or acts or omits in any manner which tantamount to an offence punishable under any provision of the Indian Penal Code, 1860 or any other law in force in India, or does anything which is actionable under the Guidelines for Suspension of Business dealings, action may be taken against such bidder / supplier / contractor as per extant guidelines of the company available on www.bhel.com and / or under applicable legal provisions.

Guidelines for suspension of business dealings is available in the webpage:

http://www.bhel.com/vender_registration/vender.php

2.18. **LIMITATION ON LIABILITY:**

Notwithstanding anything to the contrary in this Contract or LOA or Work Order or any other mutually agreed document between the parties, the maximum liability, for damages, of the contractor, its servants or agents, shall under no circumstances exceed an amount equal to the Price of the Contract or the Work Order. The Contractor shall not in any case be liable for loss of profit or special, punitive, exemplary, indirect or consequential losses whatsoever. This shall not be applicable on the recoveries made by Customer from BHEL on account of Contractor, any other type of recoveries for workmanship, material, T&P etc. due from the contractor.

2.19. **OTHER ISSUES**

2.19.2. Value of Non judicial Stamp Paper for Bank Guarantees and for Contract Agreement shall be not less than Rs. 100/- unless otherwise required under relevant statutes.

2.19.3. In case of any conflict between the General Conditions of Contract and Special Conditions of Contract, provisions contained in the Special Conditions of Contract shall prevail.

2.19.4. Unless otherwise specified in NIT, offers from consortium/ JVs shall not be considered.

Place:
Date:

Signature of Authorized Signatory
with seal & full address



Bharat Heavy Electricals Limited

(A Govt. of India Undertaking)

Power Plant Piping Unit, Thirumayam – 622 507, Tamil Nadu

Tender Notice

NON COMPLIANCE OF SAFETY RULES

NONCONFORMITY OF SAFETY RULES AND SAFETY APPLIANCES WILL BE VIEWED SERIOUSLY AND BHEL HAS RIGHT TO IMPOSE FINES ON THE CONTRACTOR/SUB-CONTRACTOR AS UNDER FOR EVERY INSTANCE OF VIOLATION NOTICED.

SN	Violation of Safety Norms	Fine (in Rs)
01	Not Wearing Safety Helmet	200/- *
02.	Not wearing Safety Belt or not anchoring life line	500/-*
03	Not wearing safety shoe	200/-*
04	Not keeping gas cylinders vertically	200/-
05	Not using flash back arrestors	100/-
06	Not wearing gloves	50/- *
07.	Grinding Without Goggles	50/- *
08.	Not using 24 V Supply For Internal Work	500/-
09.	Electrical Plugs Not used for hand Machine	100/-
10.	Not Slings properly	200/-
11.	Using Damaged Sling	200/-
12.	Lifting Cylinders Without Cage	500/-
13.	Not Using Proper Welding Cable With Lot of Joints And Not Insulated Property.	200/-
14.	Not Removing Small Scrap From Platforms	500/-
15.	Gas Cutting Without Taking Proper Precaution or Not Using Sheet Below Gas Cutting	500/-
16.	Not Maintaining Electric W Inches Which are Operated Dangerously	500/-
17.	Improper Earthing Of Electrical T&P	500/-
18	No or improper barricading	500/-
19.	Activity carried out without Safety work permit (Height work, Lifting activity, Hot work-each person/case)	1000/-

Legend:-

*: per head. For repeated violation by the same person, the penalty would be double of the previous penalty. Date of "Repeated violation" will be counted from subsequent days.

#: For repeated fatal incident in the same Unit incremental penalty to be imposed. The contractor/sub-contractor will pay 2 times the penalty compared to previously paid in case there are repeated cases of fatal incidents under the same contractor/sub-contractor for the same package in the same unit.

Any other non-conformity noticed not listed above will also be fined as deemed fit by BHEL. The decision of BHEL engineer is final on the above. The amount will be deducted from running bills of the subcontractor.

Place:
Date:

Signature of Authorized Signatory
with seal & full address

1.0 Scope

This Procedure details the various steps to be followed during the local heat treatment at Sub contractor's works

2.0 General

The fabricator should ensure full compliance to this procedure.

The local heat treatment shall be carried out in a covered place, on a levelled surface made of fire bricks. Adequate safety controls shall be exercised to avoid any electrical shock / fire during the heat treatment. The regulatory statutory approval requirements shall be taken care. The operators performing heat treatment Should have knowledge on materials to be heat treated, calibration, control during power failure, and safety. Components like Tank & Vessels shall be heat-treated in furnace only. The power supply to the heating elements shall be connected through an energy meter and sealed. For every heat treatment cycle the meter reading shall be monitored & recorded.

The following shall be ensured before heat treatment.

1. The BHEL Inspector's clearance to be obtained prior to the Heat treatment.
2. The cycle temp & soaking time shall be as indicated in the QCP / QP.
3. BHEL Inspector shall ensure.
 - a) Work order, Du, Joint identification
 - b). Material Spec.
 - c). Cycle temp.
 - d). Placement of thermo couple.
 - e). Proper Insulation before heat treatment.
 - f). The maximum no of clamps / joints shall be as indicated in the sketches.

Surveillance check to be carried out by BHEL QC/QA.

3.0 Applicable code

ASME B 31.1

ASME Sec VIII

IBR

4.0 Equipments to be used

1. Heating source
2. Finger elements
3. Insulation material
4. Thermo couple
5. 6 points continuous recorder (Minimum)
6. Compensating cables

The thermo couple recorder shall be calibrated every year in an BHEL/IBR approved lab.

5.0 Rate of Heating / Cooling

The rate of heating / cooling shall be as indicated in the QCP. The soaking temp. shall be as indicated in the QCP / QP(.) The soaking time shall be one hour / 25 mm and the minimum soaking time shall be half an hour.

6.0 For Arrangements of the Thermo Couples, – Refer pages 4 – 7.

7.0 ACTION ON POWER FAILURE

Incase of any power cut during the heat treatment the following procedure to followed.

During Heating : The whole operation shall be repeated from the beginning.

During Soaking : Heat treat (soak) subsequently for the entire soaking period.

During Cooling : Reheat to soaking temp & cool at the required rate.
(above 400°C).

8.0 RECORDS

The heat treatment cycle shall be witnessed by BHEL / QC

The entire heat treatment chart shall be approved with the approval stamp & Signature of BHEL Inspection personnel. The relevant details shall be entered in the history card.

PLACEMENT OF THERMOCOUPLES FOR BUTT JOINTS

LOCATION OF THERMOCOUPLES: -

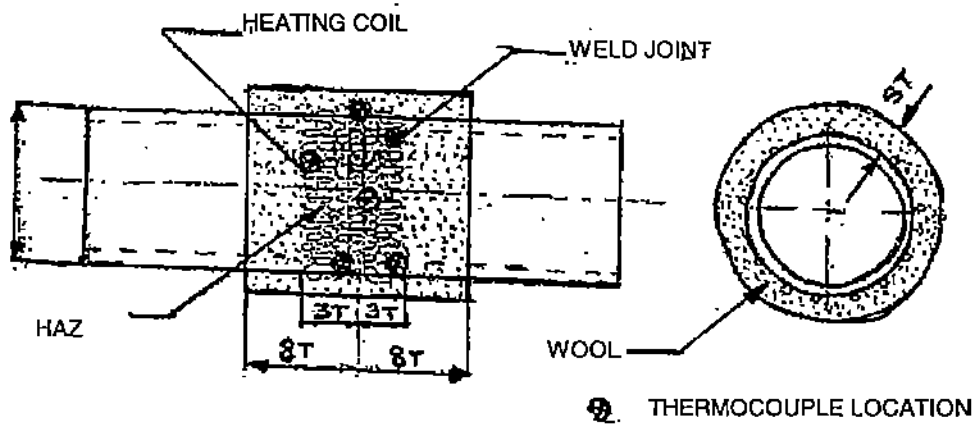

PLACEMENT OF THERMOCOUPLES FOR BRANCH JOINTS

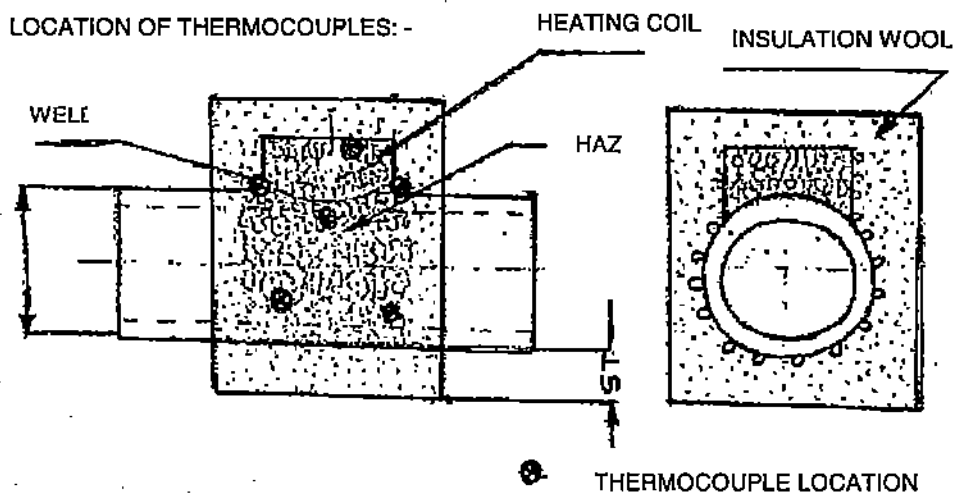

PLACEMENT OF THERMOCOUPLES FOR CLAMP ASSEMBLIES

LOCATION OF THERMOCOUPLES: -

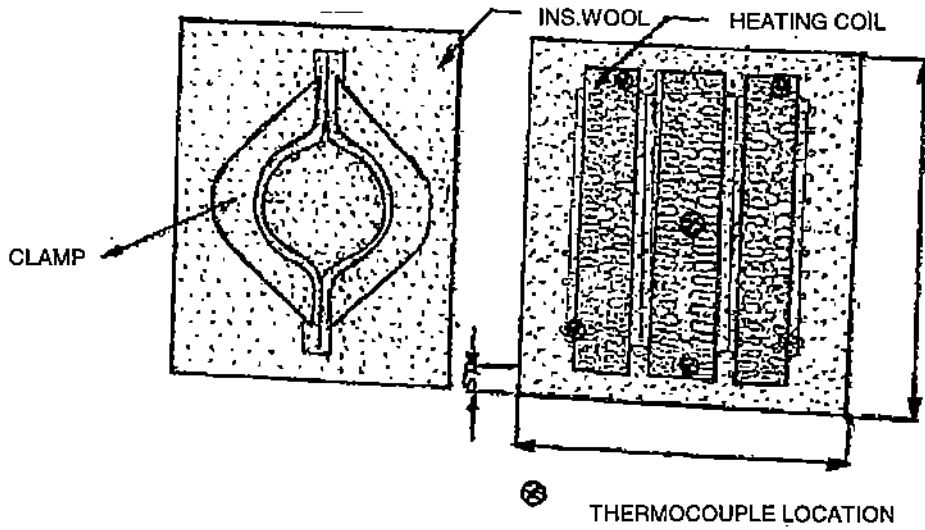

LOCATION OF THERMOCOUPLES: -

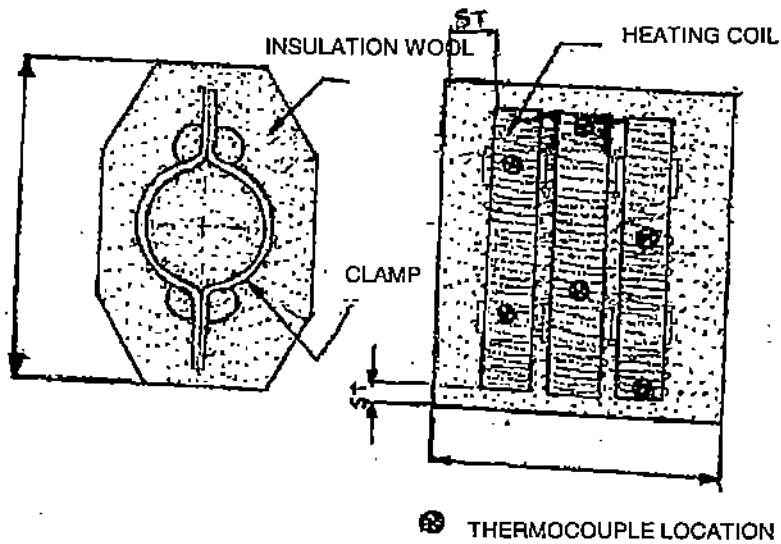

PLACEMENT OF THERMOCOUPLES FOR STUBS / NOZZLES

LOCATION OF THERMOCOUPLES: -

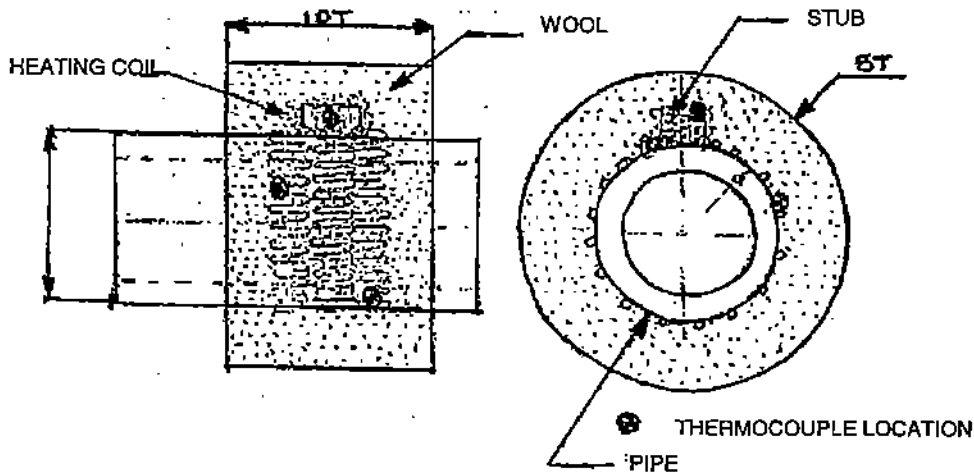

PLACEMENT OF THERMOCOUPLE FOR CLAMPS

LOCATION OF THERMOCOUPLES: -

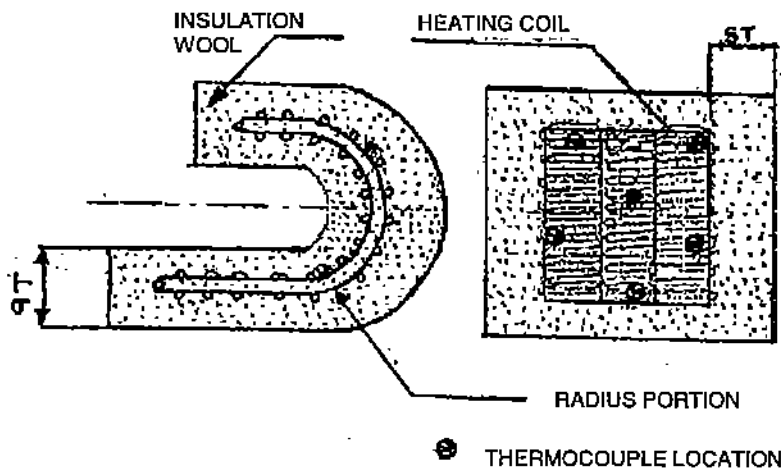

PLACEMENT OF THERMOCOUPLES FOR CARRIER PLATES

LOCATION OF THERMOCOUPLES: -

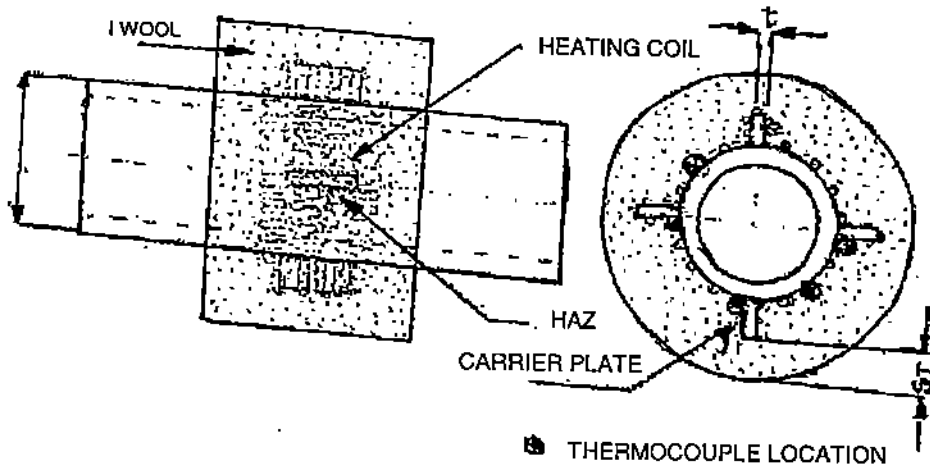

PLACEMENT OF THERMOCOUPLES FOR LUG PLATES

LOCATION OF THERMOCOUPLES: -

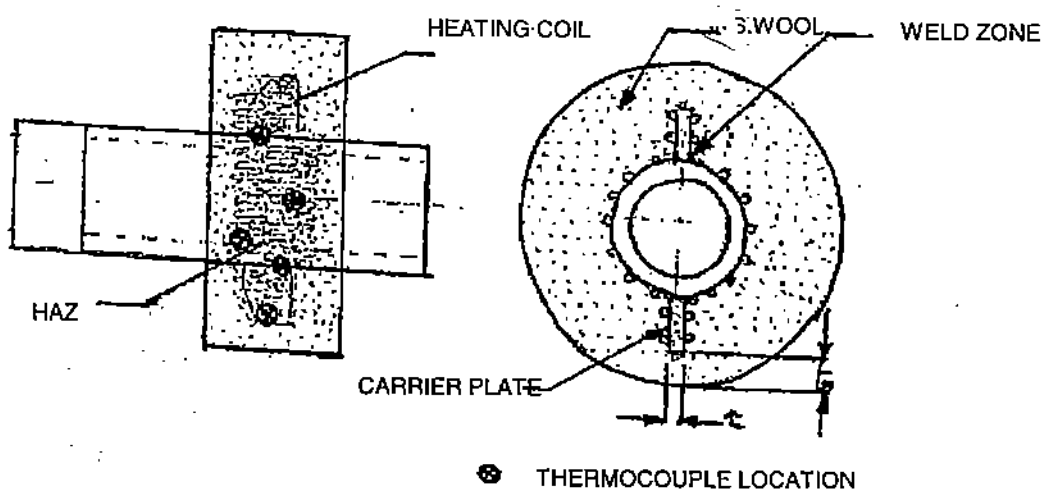

[Handwritten signature]

SL. NO.	COMPONENT & OPERATIONS	CHARACTERISTICS	CLASS	TYPE OF CHECK	QUANTUM OF CHECK	REFERENCE DOCUMENT	ACCEPTANCE NORMS	FORMAT OF RECORD	AGENCY			REMARKS	
									M	C	N		
									** 10			11	
1	2	3	4	5	6	7	8	9	D*				

1.0	MATERIAL:												
1.1	Seamless steel pipes, Tubes, Plates, Bars, Forgings & Fittings	Chemical & Mechanical Properties & Soundness	A	Review of Documents	100%	TDC / Material specification		TC			QC		Refer Note 1
2.0	INPROCESS (Refer QCP:001 (Latest) for Process Control)												
2.1	Marking, cutting # and preparation	Size, straightness, Reference. line marking* Optional butt joint, Location, W.O, DU No., Material. Identification Orientation of long seam for bending (Plate formed pipe)	B	Visual & Measurement	100%	Drawing / GMS & Cutting plan Spacing between butt joints Greater of 10D or 500mm Within ± 5 deg. from Neutral axis		R			QC		# No gas cutting on P91, P92. * Reference line at 100mm from free end.
2.2	Bending & EP												
2.2.1	Heating and Heat treatment		Time/Temp. control.	A	Review of HT charts/ Log	100%	Note 3		R			QC	
2.2.2	First off inspection (For cold bending)	Bend angle, radius, Arm length, Offset, Ovality, Thinning \$, Wrinkles @	B	Measurement & Visual	First bend	Drawing and Note 5		R			QC		\$ check thickness on tension side @ Refer Note 2 (1)

LEGEND: CI: Class (A: Critical B: Major, C: Minor) * D: Records for Data folder ** M: BHEL C: Customer N: TPI agency QC: Quality Control ND: NDT Lab. R : Record

SL. NO.	COMPONENT & OPERATIONS	CHARACTERISTICS	CLASS	TYPE OF CHECK	QUANTUM OF CHECK	REFERENCE DOCUMENT	ACCEPTANCE NORMS	FORMAT OF RECORD	AGENCY			REMARKS	
									M	C	N		
1	2	3	4	5	6	7	8	9	D*	** 10			11

2.2.3	Dimensions	Bend angle, radius, Arm length, End-to-end dimension, Offset, Ovality, Thickness \$ Wrinkles @ EP, Land OD, d1 at ends, Face out Surface check	B	Measurement & Visual	100% ++	Drawing and Notes 2 (1), 2 (2) & 5		R		QC			++100% for hot bends and 10% for others \$ check thickness on tension side and at EP ** Refer SIP: PP:16 for Edge build up, if required.
2.2.4	P91/P92 Bends after PFHT	Micro Hardness	C B	Insitu Micro Measurement*	## 100%	Uniform structure 180-300 HB (Variation within <i>the bend shall be</i> ≤ 50 HB)		R R		P. Lab QC			## 3 replicas in one bend per HT batch per grade * 3 spots at random on each bend
2.2.5	All bends (Hot/Induction)	Surface quality in bend area	B	MPI	100%	BHE:NDT:PB:MT-02							
2.3	Marking for Stub hole drilling / Attachments	Location + Orientation, EP	B	Measurement	100%	Drawing		R		QC			+ Stubs/attachments shall be 150mm away from butt joints with 25mm minimum clearance between welds
2.4	Weld fit up												
2.4.1	Butt joints	Weld angle, Mismatch, Root gap	B	Measurement	100%	Drawing		R \$\$		QC			\$\$ Records for Ø219.1 mm and above
2.4.2	Stubs & attachments	Location, Orientation, Dimensions	B	Measurement	100%	Drawing		R		QC			
2.5	Welding												
2.5.1	Welding Qualifications	Procedure qualification	B	Review of documents	100%	ASME SEC. IX		WPS		QC			
		Personnel Qualification	B	Review of documents	100%	IBR		WQR		QC			

LEGEND: CI: Class (A: Critical B: Major, C: Minor) * D: Records for Data folder ** M: BHEL C: Customer N: TPI agency QC: Quality Control ND: NDT Lab. R : Record

SL. NO.	COMPONENT & OPERATIONS	CHARACTERISTICS	CLASS	TYPE OF CHECK	QUANTUM OF CHECK	REFERENCE DOCUMENT	ACCEPTANCE NORMS	FORMAT OF RECORD	AGENCY			REMARKS	
									M	C	N		
1	2	3	4	5	6	7	8	9	D*	** 10			11

2.5.2	Weld Inspection	Weld profile, size & Surface quality	B	Measurement & visual	100%	Drawings & SIP:PP:02	R			QC			
2.6	NDE before PWHT												
2.6.1	Carrier Plate Root back gouging / grinding	Discontinuities	C	MPI	100%	BHE:NDT:PB:MT-01	R			ND			
2.6.2	Butt welds (Boiler Piping)	Soundness	A	RT*	ID ≤102, 5% ID>102 & ≤178, 10% ID>178, 100%	BHE:NDT:PB:RT-01	R			ND			% of joints are per Welder *Except P91/P92/X20
2.6.3	Butt welds (External Piping)	Soundness	A	RT*	IBR CL-I, ID ≤ 102, 10%, ID>102, 100%, CL-II: 10%	BHE:NDT:PB:RT-01	R			ND			Only for materials other than X20 % of joints are per Welder *Except P91/P92/X20.
2.6.4	Full penetration nozzle joints (OD>114.3mm) Y-piece & T-piece joints- for other than P91, P92 & X20	Soundness	A	UT/RT#	100%	BHE:NDT:PB:UT-01/ BHE:NDT:PB:RT-01 BHE:NDT:PB:MT-01	R			ND			# In lieu of UT/RT , inter stage MPI can be done for every 10mm weld deposit
2.7	Post Weld Heat Treatment	ROH, ROC, Soaking temp & Soaking time	A	Review of HT charts	100%	Note 4	R			QC			
2.8	NDE after PWHT												
2.8.1a	Full penetration nozzle joints(OD>114.3mm) Y-piece, T-piece joints & butt joints of X20.	Soundness	A	UT+ MPI	100%	BHE:NDT:PB:UT-21 BHE:NDT:PB:MT-01	R			ND			
		Hardness #	B	Measurement	100%	300 HB Max	R			QC			# for butt joints only

LEGEND: CI: Class (A: Critical B: Major, C: Minor) * D: Records for Data folder ** M: BHEL C: Customer N: TPI agency QC: Quality Control ND: NDT Lab. R : Record

SL. NO.	COMPONENT & OPERATIONS	CHARACTERISTICS	CLASS	TYPE OF CHECK	QUANTUM OF CHECK	REFERENCE DOCUMENT	ACCEPTANCE NORMS	FORMAT OF RECORD	AGENCY			REMARKS	
									M	C	N		
1	2	3	4	5	6	7	8	9	D*	** 10			11

2.8.1b	Full penetration nozzle joints(OD>114.3mm) Y-piece, T-piece joints of P91, P92	Soundness	A	UT+ MPI	100%	BHE:NDT:PB:UT-21 BHE:NDT:PB:MT-05		R		ND			
2.8.1c	Butt joints-P91 & P92	Soundness	A	(RT/UT) + <i>Wet</i> MPI		BHE:NDT:PB:RT-01 BHE:NDT:PB:UT-21 BHE:NDT:PB:MT-05		R		ND			<i>*3 spots at random on each butt joint only.</i> MT-05 for P91, P92 / X20 and MT-01 for Others (applicable for 2.8.2, 2.8.3, 2.8.4)
		Hardness*	B	Measurement		180 to 300 HB		R		QC			
2.8.2	All Branch / Stub welds	Soundness	A	MPI / Wet MPI	100%	BHE:NDT:PB:MT-01/ BHE:NDT:PB:MT-05		R		ND			
2.8.3	Carrier plate welds / Load carrying welds	Soundness	A	MPI / Wet MPI	100%	BHE:NDT:PB:MT-01/ BHE:NDT:PB:MT-05		R		ND			
2.8.4	Attachment welds (for t> 25mm in CS and all AS)	Soundness	B	MPI Wet MPI	100%	BHE:NDT:PB:MT-01/ BHE:NDT:PB:MT-05		R		ND			
2.8.5	Seal welds of RG plugs and hand hole plates.	Soundness	B	MPI & LPI	100%	BHE:NDT:PB:MT-01 & BHE:NDT:PB:PT-01		R		ND			
2.9	Dimensional inspection	Straight length, EP, Weld end thickness, Orientations, Location & height of stubs/attachments Flange rotation, Face out, Axis shift – nozzle	B	Measurement	100%	Drawing & Note 5 (Drawing +3/-1mm for down comer length) Drawing ± 3 mm Drawing ± 2 mm 1.2 per 300 mm Drawing ± 3 mm		R		QC			

LEGEND: CI: Class (A: Critical B: Major, C: Minor) * D: Records for Data folder ** M: BHEL C: Customer N: TPI agency QC: Quality Control ND: NDT Lab. R : Record

SL. NO.	COMPONENT & OPERATIONS	CHARACTERISTICS	CLASS	TYPE OF CHECK	QUANTUM OF CHECK	REFERENCE DOCUMENT	ACCEPTANCE NORMS	FORMAT OF RECORD	AGENCY			REMARKS
									M	C	N	
1	2	3	4	5	6	7	8	9	D*	**	10	11

3.0		FINAL											
3.1	Verification of completion & Final inspection	Inside cleaning, Assembly of loose parts, Review of previous records, RG plug provision, Flow direction, W.O., DU No., Specification., Melt No., BI stamp	B	Verification & Visual	100%	Drawings & Inprocess records	R			QC			@ Provide VCI pallets and tack weld end caps at 4 Spots (10mm length min.), where permitted. No tacking for X20 and P91,P92..
3.2	Painting, Preservation & Protection	Paint finish DFT EP - preservation * Colour coding #, End capping @	C	Visual Measurement Visual Visual Visual	100% Random	SIP:PP:21 & SIP:PP:22	R			QC			# Colour coding for Pipes/stubs/nozzles/Fittings. * weldable primer to be applied for 25mm Width.
3.3	Certification	Code Compliance	B	Compilation of certificates	100%	IBR forms , TC extracts	R			QC			

LEGEND: CI: Class (A: Critical B: Major, C: Minor) * D: Records for Data folder ** M: BHEL C: Customer N: TPI agency QC: Quality Control ND: NDT Lab. R : Record

NOTE 1 The materials normally used and their TDC Nos. are given below:

MATERIAL	SPECIFICATION	TDC NO.
Plates	SA 515 Gr. 70, SA 387 Gr. 12 Cl. 2, SA 387 Gr. 22 Cl. 2, SA 387 Gr 91	0:202
	SA 240 TP 304	Spec.
Pipes	SA 106 Gr. B, Gr. C, SA 335 P11, P12, P22, SA312 TP 316, TP 316L	0:101, 0:112
	SA 335 P23, P91, P92 (Code case 2179)	0:123
	12X1MØ, Steel 20	0:103
	X20CrMoV121	0:104
	15Mo3, 10CrMo910, 13CrMo44	Spec.
Tubes	SA 179, 192, SA 210 Gr. A1, Gr. C, SA 209 T1, SA 213 T2, T11, T22, T91, T92 & T23 (Code case 2199), super 304H (Code case 2328)	0:102, 0:111
	12X1MØ, Steel 20	0:103
Bars	SA 105, SA 182 F11 Cl.2, F12 Cl.2, F22 Cl. 3, F91, SA193 B7 & B16, SA182 GrF316, Sa479 TP410 condition 2.	0:309
	X20CrMoV121	0:310
Forgings	SA 105, SA 182 F11 Cl. 3 , F12 Cl.2, F22 Cl. 3, F23 (Code case 2199), F91, F92 (Code case 2179), F304, 304L, 316, 316H, 321, 321H, 347 & 347H	0:404
Fittings	SA 234 (Seamless)	0:423

NOTE 2 (1) WRINKLES: Acceptance limits for wrinkles are as given below: (Refer Figure 1).

- 1) The depth of valley / OD (d/D) shall be $\leq 3\%$
- 2) Pitch of valley / depth **of valley** (A/d) shall be ≥ 12
- 3) Wrinkles beyond acceptable limits shall be corrected. Alloy steel pipes shall be checked by LPI/MPI after correction.

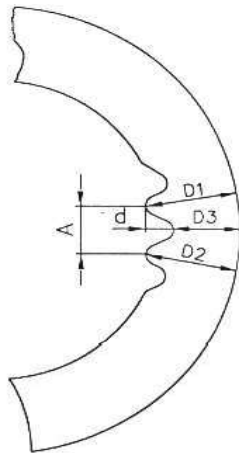

D – NOMINAL OD OF PIPE
FIGURE –1

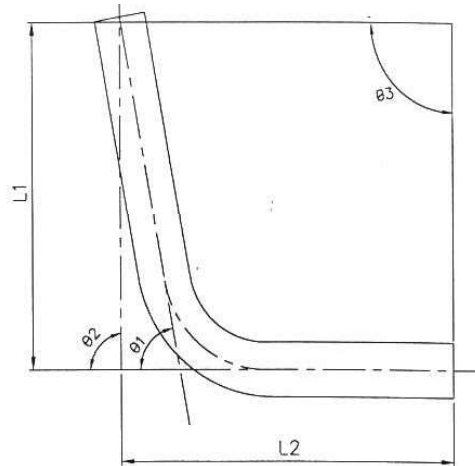

$\theta_3 = \theta_2$ =REQUIRED ANGLE OF BEND
FIGURE –2

NOTE 2 (2) TAPER MARKING

For deviation in angle of bend, between 0.5° and 2° , taper marking can be done as per the following Procedure (Refer Figure 2).

- A) The reference axis of the pipe bend is to be centre punched at 100mm from end of arm of the pipe bend as well as at the working point (Tangent Point).
- B) Place the straight edges on both the axes of longer as well as shorter arms.
- C) At the intersection of the straight edges, the external angle θ_1 shall be measured as shown.
- D) The straight edge has to be pivoted about the centre punches at the shorter arms near the end of the pipe. The other end of the straight edge is to be moved until the desired angle is obtained at the intersection point
- E) The arm length L_1 & L_2 shall be marked from the intersection point.
- F) After marking, the ends are to be chamfered normal to the new axis, such a way that the resulting face angle θ_3 is the required angle.

Note 3.0 Post forming heat treatment

Cold and hot bending of pipes (OD > 114.3 mm)			Temp. in °C #
Material	Cold bending (Temp. < 590)	Hot bending	Incremental bending *
P1@, 15Mo3 Steel 20	When t > 19mm, SR at 610±15	Heating: 900 - 1010 Bending not below 670 SR at 610±15 (No SR if bending is completed above 870)	Heating: 900 – 1010 if t ≤ 40mm, No SR If t > 40mm, SR at 610±15
P4, 13CrMo44	SR at 665±15	Heating: 920 - 1010 Bending not below 720 Normalize at 920-960, Temper at 665±15	Heating: 920 - 1010 Normalize at 920-960, Temper at 665±15
P5A, 10CrMo910	SR at 695±15	Heating: 920 - 1010 Bending not below 750 Normalize at 920-960, Temper at 695±15	Heating: Tension side 770-780 Normalize at 920-960, Temper at 695±15
P15E Group 1 \$	Not applicable	Heating: 1050 - 1100 Bending not below 1000 Normalize at 1040-1060, Temper at 760-780	Heating: 1000-1100 Normalize at 1040-1060, Temper at 760-780
12X1MØ	Not applicable	Heating: 950 - 1100 Bending not below 750 Normalize at 950-980, Temper at 720-750	Heating: 950–1100 Normalize at 950-980, Temper at 720-750
X20CrMoV121 \$	Not applicable	Heating: 850 - 1100 Bending not below 750 Normalize at 1020-1050, Temper at 740-760	Heating: 850–1100 Normalize at 1020-1050, Temper at 740-760

Cold and hot bending of pipes (OD ≤ 114.3 mm)		Temp. in °C #
Material	Cold bending (Temp. < 590)	Hot bending
P1@, 15Mo3 Steel 20	When t > 19mm, SR at 610±15	Hot bend at 870 – 900, SR Nil
P4, 13CrMo44	When R/D < 2 or t > 13mm, SR at 665±15	Hot bend at 870 – 900, If R/D < 2, SR at 665±15
P5A, 10CrMo910	When R/D < 2 or t > 13mm, SR at 695±15	Hot bend at 870 – 900, SR at 695 ±15
P15E Group 1 \$	I) For Design Temperature ≤ 540°C (a) R/D < 2.5, SR at 760±10°C (b) R/D ≥ 2.5, No HT. II) For Design Temperature > 540 & ≤ 600°C (a) R/D < 2 - Normalize at 1040-1070°C & Temper at 760±10°C (b) R/D ≥ 2 & < 10 -- SR at 760±10°C (c) R/D ≥ 10, No HT. III) For Design Temp. > 600°C (a) R/D < 2.5 - Normalize at 1040- 1070°C & Temper at 760±10°C (b) R/D ≥ 2.5 & < 10 -- SR at 760±10°C (c) R/D ≥ 10, No HT.	Hot bend at 1050 – 1100 Normalize at 1040-1060 Temper at 750 - 770
12X1MØ	When R/D < 2 or t > 13mm, SR at 725±15	Hot bend at 950 – 1100 Normalize at 950-980 Temper at 720 - 750

P8 SA 312 TP316	R/D ≥ 2.5 No HT R/D < 2.5 Solution HT 1100-1150°C/30 minutes' minimum. Ensure the pipe ends are covered by SS end caps during the solution annealing.	Hot bend at 980-1120°C Solution HT: 1100-1150 °C/30 minutes' minimum. Ensure the pipe ends are covered by SS end caps during the solution annealing.
--------------------	---	--

* For incremental bending, the parameters shall be suitably selected to ensure uniform heating of the entire thickness. The temperature shall not fall below the minimum specified during bending.

§ For X20, P91, P92 bends:

After hot bending the temperature shall be brought down to 0 to 100°C. Subsequently Normalizing shall be completed within 72 hours. After completion of Normalizing, the temperature shall be brought down to 0 to 100°C, subsequently tempering shall be carried out within 72 hours. Tempering shall not be clubbed with PWHT. Normalizing and tempering of P91 shall be done encompassing the entire component.

For pipe bends, thickness "T" for determining soaking *time, shall be the measured maximum thickness available at the bend intrados region.*

@ For P1 material-

If OD < 141.3 & R/D ≤ 1.5, carry out SR at 610 ± 15°C;

If OD > 141.3 mm & R/D ≤ 2.5, carry out SR at 610 ± 15°C.

NOTE 4: Post weld heat treatment

- a) PWHT controls shall be as per QCP:001 (latest). Soaking for PWHT shall be at the rate of 2.5 minutes per mm of thickest weld (minimum 30 minutes for P1, P3, P4; minimum 1 hour for P5A, **P91 and P92** materials). Soaking time for 12X1MØ header material shall be 4 minutes per mm of applicable thickness with a minimum of 180 minutes.

@ Preheat temperature for castings and forgings of P5A shall be 220°C

\$\$\$ Preheating is not required for P1 group 1 (Gr. B), steel 20, 15 Mo3 materials for thickness ≤ 25 mm.

##Preheat shall be maintained for P91/P92 till welding is completed. Interpass temperature for P91/P92 welding shall be limited to 350°C. After completion of welding on P91/P92, allow the component to cool below 95°C. Immediately following cooling, all weldments must receive:

a. immediate PWHT within 8 hours or

b. Hydrogen bake at 260°C to 400°C. Hold for 1 hour per inch of thickness (Minimum 30 minutes and Maximum 4 hrs.). Cool in still air. PWHT shall be done within 7 days after the completion of the hydrogen baking.

Alternatively, after welding completion, the preheat temperature shall be maintained so that the weldments are kept above 150°C until the furnace is ready for PWHT. Allow the component to cool to less than 95°C before loading into furnace.

The component must be:

1) maintained in a dry environment or above 95°C till PWHT.

2) stored without application of significant thermal or mechanical loads until PWHT.

3) Dry environment means that at no time shall the weld come into contact with liquids, including atmospheric condensation (water).

Heating and cooling rates for PWHT of P91/P92 shall be as per QCP: 001 (latest); but shall not exceed 140°C /hour, and Controlled cooling shall be done up to 350°C.

* If not preheated.

** For X20 piping: Producer gas shall not be used for heating and heat treatment. Inter pass temp: 450 °C (max.). After the completion of the welding, the welds shall be maintained at 80-100°C (Optimum: 90°C) till PWHT (SR) is carried out.

Stress Relieving Cycle: 740-760°C.

Soaking : Thickness 60mm and below : 2 hrs (Min.)

Thickness above 60mm : 3 hrs (Min.).

Heating Rate: Thickness below 40 mm : 200°C/hr. (Max.)

Thickness between 40-70mm : 120°C/hr.(max.)

Thickness between 70-95mm : 85°C./hr.(max.)

Cooling Rate: Thickness below 40 mm : 150°C/hr.

Thickness between 40-70mm : 100°C/hr.

Thickness between 70-95mm : 80°C/hr.

Controlled Cooling : upto 350°C.

Maintain at: 80°-100°C for 1½ hrs. minimum (Optimum: 90°C.)

Table-1 Post weld heat treatment for Butt welds/stub welds/nozzle welds (other than attachment welds)

BUTT / STUB BASE METAL	P1 Group 1 (Gr. B), Steel 20, 15 Mo3, P1 Group 2 (Gr.C) t≤19	P1 Group 1 (Gr. B), Steel 20, 15 Mo3, P1 Group 2 (Gr.C) t>19	P3 (OD ≤ 127 & T ≤ 13)f	P3 (OD >127 or T>13)	P4, 13CrMo44 (OD ≤ 127 & T≤13) (\$)	P4, 13CrMo44 (OD >127 or T>13) (\$)	P5A, 10CrMo910 (OD ≤ 102 & T≤8) (@)	P5A, 10CrMo910 (OD>102 or T>8) (@)	P15 E Group 1 (P91/P92)	X20CrMov121 **	12X1M (t up to 52mm)	P8
P1 Group 1 (Gr. B), Steel 20, 15 Mo3, P1 Group 2 (Gr.C) t ≤ 19	Pre Heat=Nil Post Heat: Nil PWHT: Nil	Pre Heat=150 (\$\$\$) Post Heat: Nil (150 for 2 hrs for P1 Group 2) PWHT: 610±15	Pre Heat=150 Post Heat: Nil PWHT: If PH – Nil, Else 635±15	Pre Heat=150 Post Heat: Nil PWHT: 635±15	Pre Heat=150 Post Heat: Nil PWHT: If PH – Nil, Else 665±15	Pre Heat=150 Post Heat: Nil PWHT: 665±15	Pre Heat=150 Post Heat: Nil PWHT: If PH – Nil, Else 695±15	Pre Heat=150 Post Heat: Nil PWHT: 695±15	NA	NA	NA	NA
P1 Group 1 (Gr. B), Steel 20, 15 Mo3, P1 Group 2 (Gr.C) t>19	Pre Heat=150 (\$\$\$) Post Heat: Nil (150 for 2 hrs for P1 Group 2) PWHT: 610±15	Pre Heat=150 (\$\$\$) Post Heat: Nil (150 for 2 hrs for P1 Group 2) PWHT: 610±15	Pre Heat=150 (\$\$\$) Post Heat: Nil (150 for 2 hrs for P1 Group 2) PWHT: If PH 610±15 , else 635±15	Pre Heat=150 (150 for 2 hrs for P1 Group 2) PWHT: 635±15	PH=150 (\$\$\$) Post Heat: Nil (150 for 2 hrs for P1 Group 2) PWHT: If PH 610±15 , else 665±15	PH=150 Post Heat: Nil (150 for 2 hrs for P1 Group 2) PWHT: 665±15	PH=150 (\$\$\$) Post Heat: Nil (150 for 2 hrs for P1 Group 2) PWHT: If PH 610±15 else 69±15	PH=150 Post Heat: Nil (150 for 2 hrs for P1 Group 2) PWHT:695±15	NA	NA	NA	NA
P3 (OD ≤127 & T≤13)	NA	NA	NA	NA	NA	NA	NA	NA	NA	NA	NA	NA
P3 (OD >127 or T>13)	NA	NA	NA	NA	NA	NA	NA	NA	NA	NA	NA	NA
P4, 13CrMo44 (OD ≤127 & T≤13) (\$)	PH=150 Post Heat: Nil PWHT: 665±15 (*)	PH=150 (\$\$\$) Post Heat: Nil (150 for 2 hrs for P1 Group 2) PWHT: if PH 610±15 , else 665±15	PH=150 Post Heat: Nil PWHT: If PH – Nil, Else 665±15	PH=150 Post Heat: Nil PWHT: 665±15	PH=150 Post Heat: Nil PWHT: If PH – Nil, Else 665±15	PH=150 Post Heat: Nil PWHT: 665±15	PH=150 Post Heat: Nil PWHT: If PH – Nil, Else 695±15	PH=150 Post Heat: Nil PWHT: 695±15	NA	NA	NA	NA
P4, 13CrMo44 (OD >127 or T>13) (\$)	PH=150 Post Heat: Nil PWHT: 665±15	PH=150 Post Heat: Nil (150 for 2 hrs for P1 Group 2) PWHT: 665±15	PH=150 Post Heat: Nil PWHT: 665±15	PH=150 Post Heat: Nil PWHT: 665±15	PH=150 Post Heat: Nil PWHT: 665±15	PH=150 Post Heat: Nil PWHT: 665±15	PH=150 Post Heat: Nil PWHT: 695±15	PH=150 Post Heat: Nil PWHT: 695±15	NA	NA	NA	NA
P5A, 10CrMo910 (OD ≤ 102 & T ≤ 8) (@)	PH=150 Post Heat: Nil PWHT: If PH- Nil, Else 695±15	PH=150 (\$\$\$) Post Heat: Nil (150 for 2 hrs for P1 Group 2) PWHT: 610±15 , else 695±15	PH=150 Post Heat: Nil PWHT: If PH- Nil, Else 695±15	PH=150 Post Heat: Nil PWHT: 635±15	PH=150 Post Heat: Nil PWHT: If PH- Nil, Else 695±15	PH=150 Post Heat: Nil PWHT: 665±15	PH=150 Post Heat: Nil PWHT: If PH- Nil, Else 695±15	PH=150 Post Heat: Nil PWHT: 695±15	PH=220 Post Heat:280 for 2 hours PWHT: 760±10##	NA	NA	PH=150 Post Heat: Nil PWHT: 695±15(*)

Table-1 Post weld heat treatment for Butt welds/stub welds/nozzle welds (other than attachment welds)

BUTT / STUB BASE METAL	P1 Group 1 (Gr.B), Steel 20, 15 Mo3, P1 Group 2 (Gr.C) t≤19	P1 Group 1 (Gr.B), Steel 20, 15 Mo3, P1 Group 2 (Gr.C) t>19	P3 (OD ≤127 & T≤13)	P3 (OD >127 or T>13)	P4, 13CrMo44 (OD ≤ 127 & T≤13) (\$)	P4, 13CrMo44 (OD >127 or T>13) (\$)	P5A, 10CrMo910 (OD ≤102 & T≤8) (@)	P5A, 10CrMo910 (OD>102 or T>8) (@)	P15 E Group 1 (P91/P92)	X20CrMov121 **	12X1M (t up to 52mm)	P8
P5A(OD>102 or T>8) (@)	PH=150 Post Heat: Nil PWHT: 695±15	PH=150 Post Heat: Nil (150 for 2 hrs for P1 Group 2) PWHT:695±15	PH=150 Post Heat: Nil PWHT: 695±15	PH=150 Post Heat: Nil PWHT: 695±15	PH=150 Post Heat: Nil PWHT: 695±15	PH=150 Post Heat: Nil PWHT: 695±15	PH=150 Post Heat: Nil PWHT: 695±15	PH=150 Post Heat: Nil PWHT: 695±15	PH=220 Post Heat:280 for 2 hours PWHT: 760±10 ##		PH:220 Post Heat: Nil PWHT: 725±15	PH=150 Post Heat: Nil PWHT: 695±15
P15 E Group 1 (P91/P92)	NA	NA	NA	NA	NA	NA	PH=220 Post Heat:280 for 2 hours PWHT: 760±10 ##	PH=220 Post Heat:280 for 2 hours PWHT: 760±10 ##	PH=220 Post Heat:280 for 2 hours PWHT: 760±10 ##	PH=220 Post Heat:280 for 2 hours PWHT: 760±10 ##	NA	NA
X20CrMov121 **	NA		NA	NA	NA	NA	NA	NA	NA	PH: 250-300 for GTAW and 400- 450 for SMAW Post Heat:80- 100°C for 90 minutes minimum PWHT: 740-760	NA	NA
12X1M (t up to 52mm)	NA	NA	NA	NA	NA	NA	NA	NA	NA	NA	PH:220 Post Heat: Nil PWHT: 725±15	NA
P8	NA	NA	NA	NA	NA	NA	PH=150 Post Heat: Nil PWHT: 695±15(*)	PH=150 Post Heat: Nil PWHT: 695±15	NA	NA	NA	PH=Nil Post Heat=Nil PWHT=Nil

Table-2 Post weld heat treatment (PWHT) temperatures (°C) for Non Pressure Part Attachment welds

Base Material (Pressure Part)	Attachment material (Non-pressure part)	Preheat	Post Heat	PWHT
P1 Group 1, steel 20, 15 Mo3, P1 Group 2 (t≤19)	Any	Nil	Nil	Nil if throat thickness ≤19 else 610±15
P1 Group 1, steel 20, 15 Mo3, P1 Group 2 (t>19)	Any	150	Nil (150 for 2 hours for P1 Group 2)	610±15
P3 Group (OD ≤127 & t13)	Any	150	Nil	Nil if throat thickness ≤13 else 635±15
P3 Group (OD>127 or t>13)	Any	150	Nil	635±15
P4 Group (OD ≤127 & t≤13)	Any	150	Nil	Nil if throat thickness ≤13 else 665±15
P4 Group (OD>127 or t>13)	Any	150	Nil	665±15
P5A Group (OD ≤102 & t≤8)	Any	150/ 220 @	Nil	1. Nil if throat thickness ≤8 else 695±15 2. 760±10(only if Gr 91/92 attachment)
P5A Group (OD>102 or t>8)	Any	150/ 220 @	Nil	1. 695±15 2. 760±10 (only if Gr 91/92 attachment)
P91/92	Any	220	280 for 2 hours	760±10
P8 Group	P1 Group 1, steel 20, 15 Mo3, P1 Group 2 (t≤19)	150	Nil (150 for 2 hours for P1 Group 2)	Nil if throat thickness ≤19 else 610±15
	P1 Group 1, steel 20, 15 Mo3, P1 Group 2 (t>19)	150	Nil (150 for 2 hours for P1 Group 2)	610±15
	P3 Group (t≤13)	150	Nil	Nil if throat thickness ≤13 else 635±15
	P3 Group (t>13)	150	Nil	635±15
	P4 Group (t≤13)	150	Nil	Nil if throat thickness ≤13 else 665±15
	P4 Group (t>13)	150	Nil	665±15
	P5A Group (t≤8)	150/ 220 @	Nil	Nil if throat thickness ≤8 else 695±15
	P5A Group (t>8)	150/ 220 @	Nil	695±15
	P91/92	220	280 for 2 hours	760±10
P8	Nil	Nil	Nil	

b) For this special combination as mentioned below the Post weld heat treatment cycle for the total assembly to be carried out is 760±10°C.

